



## **BCI® / AJS® Flange Nailing Splits at Bearing Supports**

When supported by a wall or beam, the bottom flange of BCI® / AJS® joists shall be nailed to the support with two 8d x 2.5" long nails (one on each side of the web). In addition, some types of joist hangers also require flange nailing (see corresponding hanger literature).

Reaction design values are determined by full-size tests on wood I-joists in accordance with ASTM D5055, *Standard Specification for Establishing and Monitoring Structural Capacities of Prefabricated Wood I-Joists*. An additional factor of safety is applied to the reaction value beyond what is normally applied to other wood design properties. This factor accounts for "...normal construction tolerances which may reduce specified bearing length, minor damage to joist ends during installation..." (ASTM D5055 section X6.2.2). Thus, minor splitting due to flange nailing is expected and accounted for in the reaction design value.

Boise Cascade EWP Engineering has conducted specific testing on flange nailing and corresponding splitting. From this testing, splitting that does not exceed a maximum length of 3" measured from the inside face of the support does not reduce the reaction capacity of the joist. For splits that exceed 3" up to 12", the joist shall be reinforced as shown below:

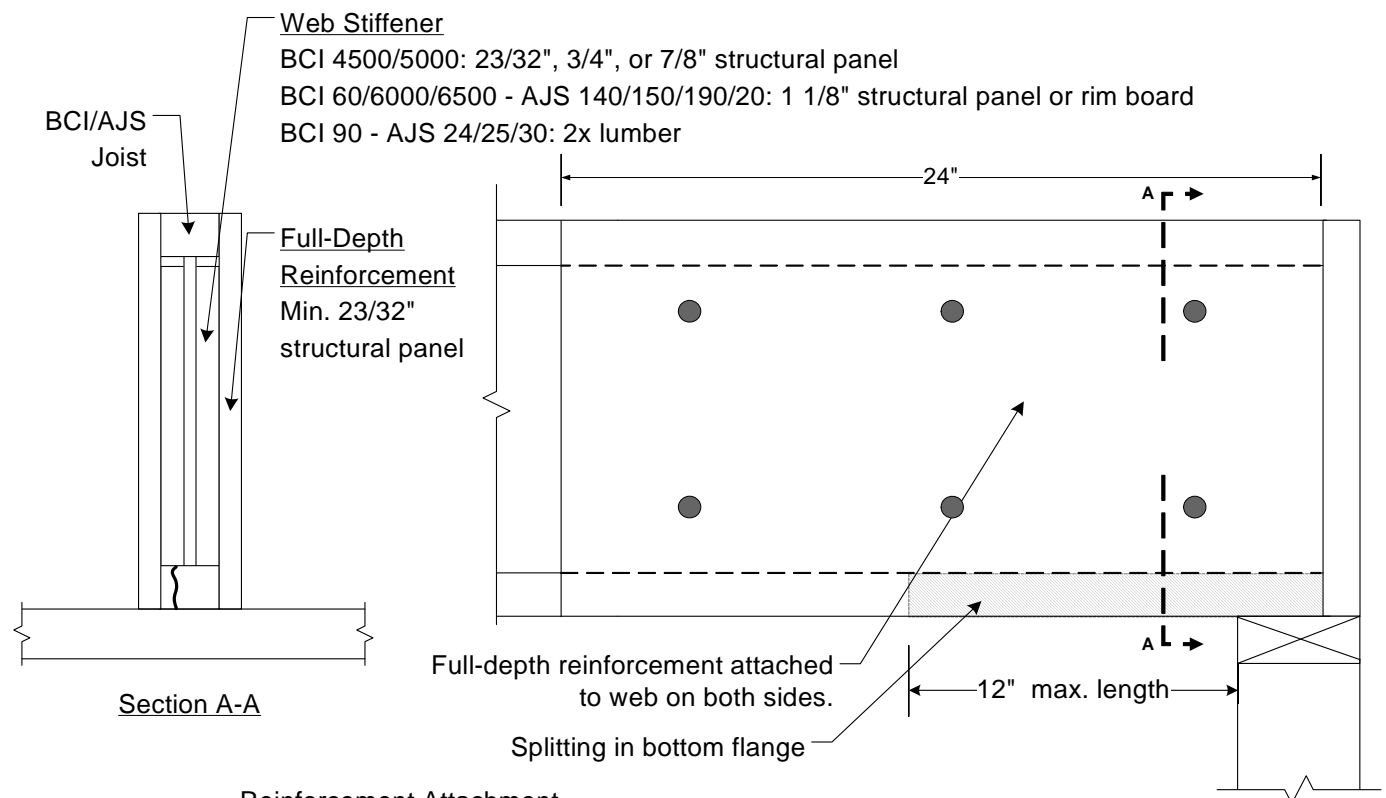

### Reinforcement Attachment

- 1) Apply construction adhesive to all contact surfaces.
- 2) Nail into the web with (6) 10d nails, each side of joist (do not nail into either flange).



**For Splits that Exceed 12”**

The joist shall be headered off to the adjacent joist if those joists are structurally adequate to support the additional load. Please refer to the following table for uniformly loaded (no point loads besides the header) floor joists; joists may only be headered off if the spans are equal to or less than the values listed.

Joist Depth	Maximum Span Length for Head-Out	
	Without Web Stiffeners	With Web Stiffeners
9 1/2”	12’-2”	12’-9”
11 7/8”	12’-2”	14’-6”
14”	12’-2”	15’-10”
16”	15’-1”	16’-6”

Note: Table assumes 40/12 psf loading and max joist spacing = 24” o.c.

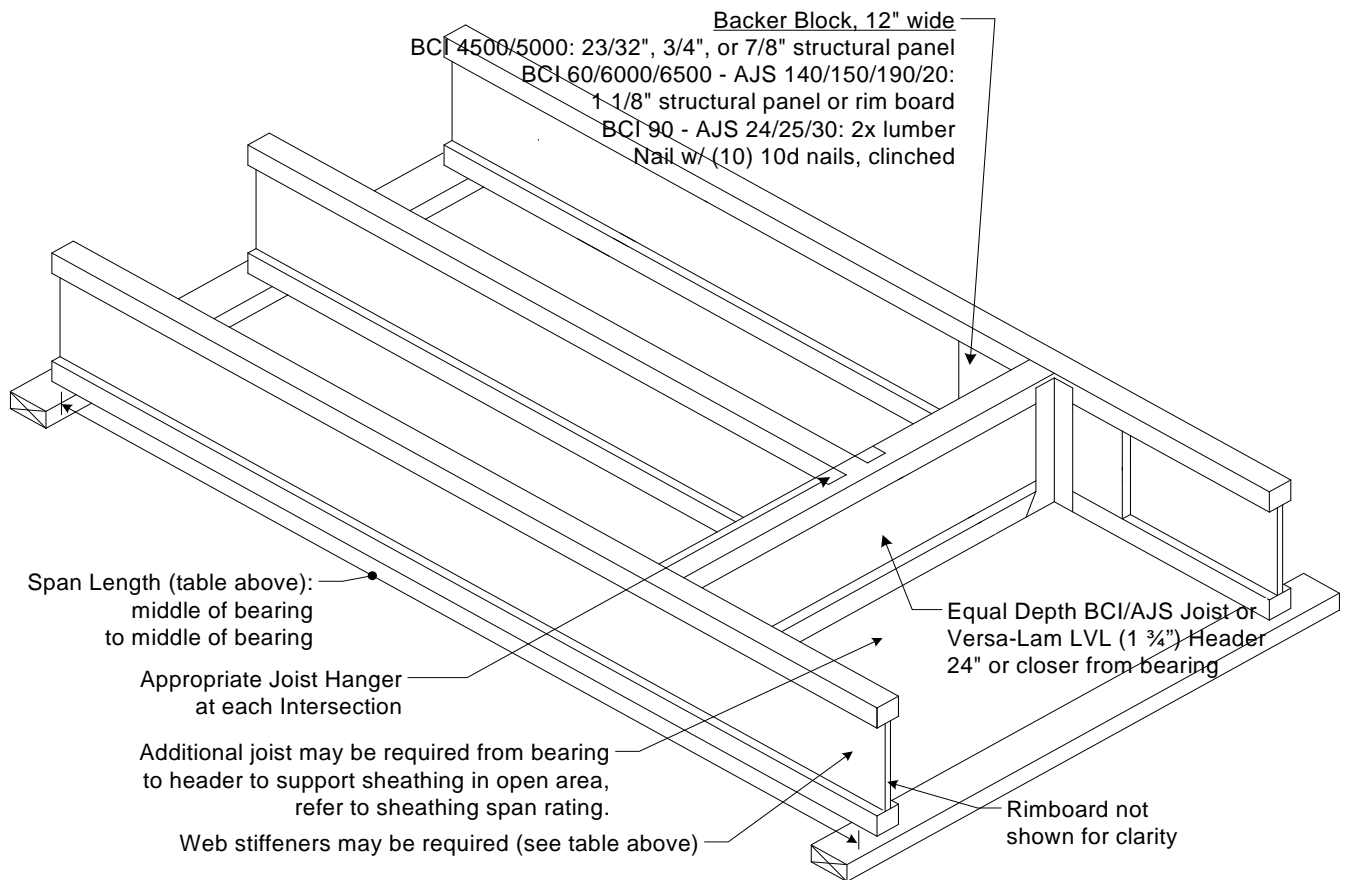

**Splitting in Top Flanges at Bearing**

Splitting may occur in the top flanges from the use of larger nails or angled nailing of the rimboard-to-flange end connection. Since the stress in the top flange at end bearings is minimal, such splitting does not significantly affect the joist’s strength capacity.