



- I-Codes provide recognition in all 50 states
- Specialty code recognition

ICC-ES Evaluation Report

Reissued March 2022

ESR-4332

This report is subject to renewal March 2024.

DIVISION: 08 00 00—OPENINGS
Section: 08 95 43—Vents / Foundation Flood Vents

REPORT HOLDER:

SMART PRODUCT INNOVATIONS, INC.

EVALUATION SUBJECT:

**FREEDOM FLOOD VENT™ AUTOMATIC FOUNDATION
FLOOD VENT: MODEL FFV-1608**

1.0 EVALUATION SCOPE

Compliance with the following codes:

- 2021, 2018, 2015, 2012, 2009 and 2006 *International Building Code*® (IBC)
- 2021, 2018, 2015, 2012, 2009 and 2006 *International Residential Code*® (IRC)

Properties evaluated:

- Physical operation
- Water flow
- Weathering

2.0 USES

The model FFV-1608 Freedom Flood Vent™ is used to equalize hydrostatic pressure on walls of enclosures subject to rising or falling floodwaters. With the cover removed, the model FFV-1608 also provides natural air ventilation.

3.0 DESCRIPTION

3.1 General:

The model FFV-1608 Freedom Flood Vent™ is an engineered mechanically operated in-wall flood vent (FV) that automatically allows floodwater to enter an enclosed area and exit. The FV is comprised of a polycarbonate frame with mounting flange and a polycarbonate horizontally pivoting door. When subjected to rising water, the model FFV-1608 Freedom Flood Vent™ door is activated and pivots to allow water and debris to flow in either direction to equalize hydrostatic pressure from one side of the enclosure to the other. The FV features a removable polycarbonate cover. The FV door will activate and pivot when subjected to rising water with or without the polycarbonate cover installed.

3.2 Engineered Opening:

The FV complies with the design principle noted in Section 2.7.2.2 and Section 2.7.3 of ASCE/ SEI 24-14 (2021, 2018 and 2015 IBC and IRC) [Section 2.6.2.2 of ASCE/ SEI 24-05 (2012, 2009, 2006 IBC and IRC)] for a maximum rate of rise and fall of 5.0 feet per hour (0.423 mm/s). In order to comply with the engineered opening requirement of ASCE/ SEI 24, Freedom Flood Vent™ FVs must be installed in accordance with Section 4.0 below. See Table 1 for vent size and maximum allowable area coverage for a single vent.

4.0 DESIGN AND INSTALLATION

The model FFV-1608 Freedom Flood Vent™ is designed to be installed into walls or overhead doors of existing or new construction. Installation of the vent must be in accordance with the manufacturer's instructions, the applicable code, and this report. In order to comply with the engineered opening design principle noted in Sections 2.7.2.2 and 2.7.3 of ASCE/ SEI 24-14 (2021, 2018 and 2015 IBC and IRC) [Section 2.6.2.2 of ASCE/ SEI 24-05 (2012, 2009, 2006 IBC and IRC)], the Freedom Flood Vent™ must be installed as follows:

- With a minimum of two openings on different sides of each enclosed area.
- With a minimum of one FV for every 250 square feet (23.2 m²) of enclosed area.
- Below the base flood elevation.
- With the bottom of the vent located a maximum of 12 inches (305.4 mm) above the higher of the final interior grade or floor and the finished exterior grade immediately under each opening.

5.0 CONDITIONS OF USE

The Freedom Flood Vent™ described in this report complies with, or is a suitable alternative to what is specified in, those codes listed in Section 1.0 of this report, subject to the following conditions:

- 5.1 The model FFV-1608 Freedom Flood Vent™ unit must be installed in accordance with this report, the applicable code and the manufacturer's published installation instructions. In the event of a conflict, the instructions in this report shall govern.
- 5.2 The model FFV-1608 Freedom Flood Vent™ unit must not be used in place of "breakaway walls" in coastal

high hazard areas, but are permitted for use in conjunction with breakaway walls in other areas.

5.3 Use of the Freedom Flood Vent as under-floor space ventilation is outside the scope of this report.

6.0 EVIDENCE SUBMITTED

Data in accordance with the ICC-ES Acceptance Criteria for Mechanically Operated Flood Vents (AC364), dated August 2015 (editorially revised February 2021).

7.0 IDENTIFICATION

7.1 The Freedom Flood Vent™ model described in this report must be identified by a label bearing the manufacturer's name (Smart Product Innovations, Inc.) and the evaluation report number (ESR-4332).

7.2 The report holder's contact information is the following:

SMART PRODUCT INNOVATIONS, INC.
 430 ANDBRO DRIVE, UNIT 1
 PITMAN, NEW JERSEY 08071
 (800) 507-1527
www.freedomfloodvent.com
info@freedomfloodvent.co

TABLE 1—FREEDOM FLOOD VENT™

MODEL NAME	MODEL NUMBER	MODEL SIZE	COVERAGE (sq. ft.)
Freedom Flood Vent™	FFV-1608	15 ³ / ₄ " X 8 ¹ / ₁₆ "	250

For SI: 1 inch = 25.4 mm

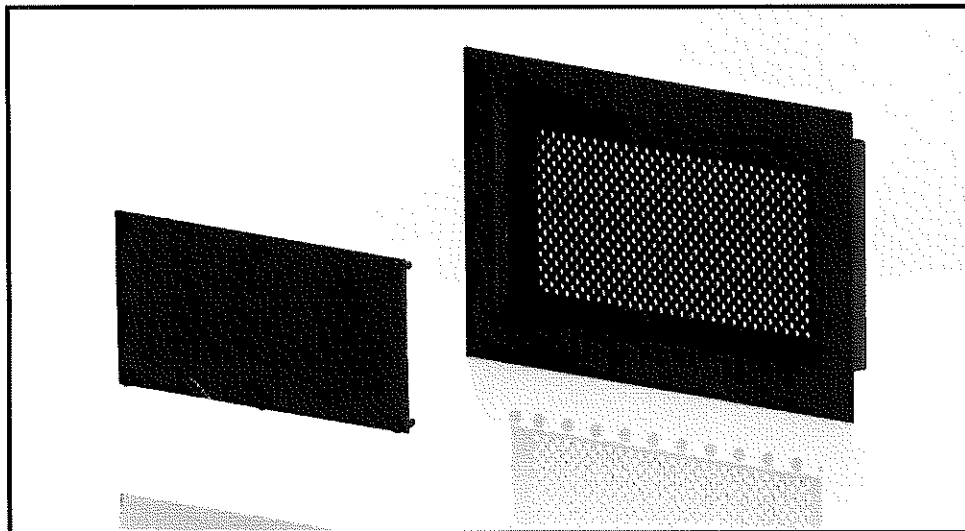

FIGURE 1—MODEL FFV-1608 FREEDOM FLOOD VENT™; SHOWN WITH COVER REMOVED

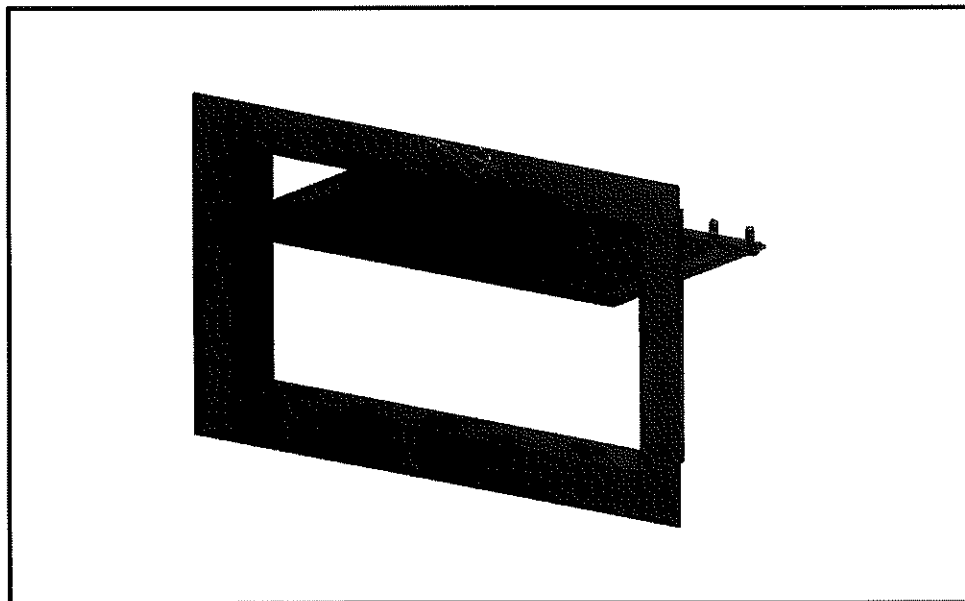

FIGURE 2—MODEL FFV-1608 FREEDOM FLOOD VENT™; SHOWN WITH FLOOD DOOR PIVOTED OPEN