

Job 23040053-01	Truss A1	Truss Type Piggyback Base	Qty 5	Ply 1	David Weekly-11 Serenity-Roof-B326 A Job Reference (optional)	I57767102
--------------------	-------------	------------------------------	----------	----------	--	-----------

Carter Components (Sanford), Sanford, NC - 27332,

Run: 8.53 S Mar 9 2023 Print: 8.530 S Mar 9 2023 MiTek Industries, Inc. Thu Apr 13 16:16:22
ID:mYsmbkyYcArRj?LeVX2KyzRQmV-RfC?PsB70Hq3NSgPqnL8w3ulTxBGKWRCDoi7J4zJC?f

Page: 1

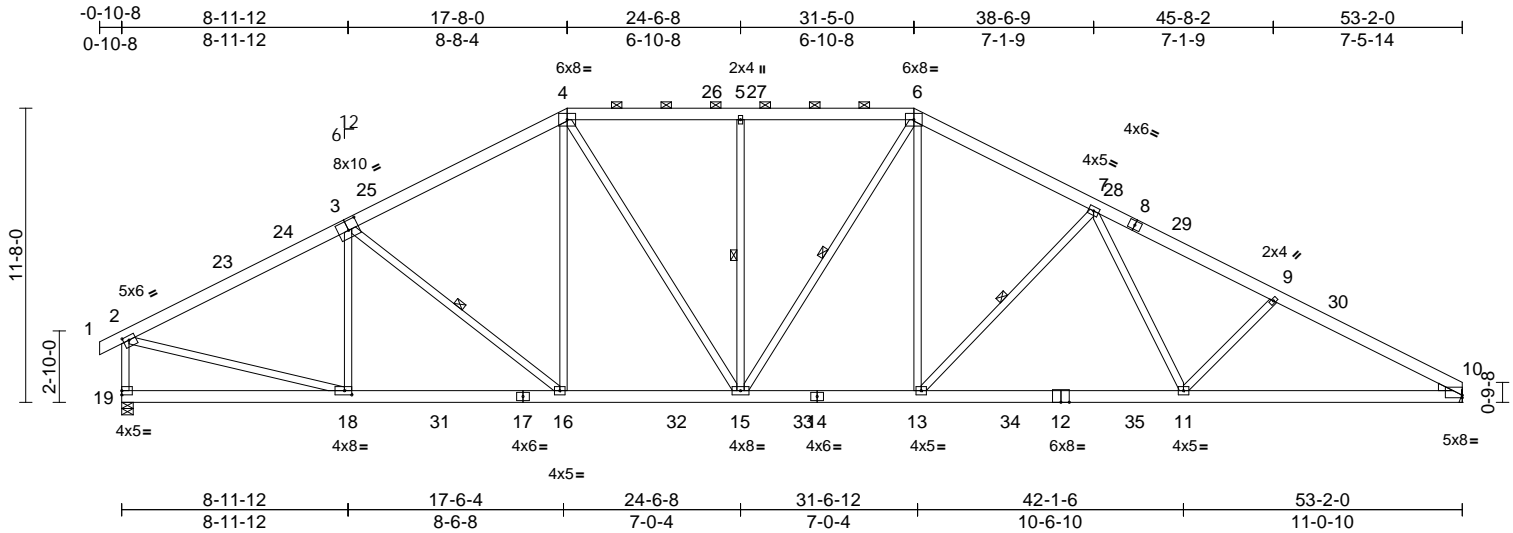

Scale = 1:91.4

Plate Offsets (X, Y): [2:0-2-12,0-2-0], [3:0-5-0,0-4-8], [10:Edge,0-1-3], [18:0-3-8,0-2-0]

Loading	(psf)	Spacing	2-0-0	CSI	DEFL	in	(loc)	l/defl	L/d	PLATES	GRIP	
TCLL (roof)	20.0	Plate Grip DOL	1.15	TC	0.87	Vert(LL)	-0.30	11-13	>999	240	MT20	244/190
Snow (Pf)	20.0	Lumber DOL	1.15	BC	0.96	Vert(CT)	-0.51	11-13	>999	180		
TCDL	10.0	Rep Stress Incr	YES	WB	0.68	Horz(CT)	0.12	10	n/a	n/a		
BCLL	0.0*	Code	IRC2018/TPI2014	Matrix-MSH								
BCDL	10.0											
											Weight: 424 lb	FT = 20%

- LUMBER**
- TOP CHORD 2x6 SP No.2
BOT CHORD 2x6 SP 2400F 2.0E *Except*
14-12,17-14:2x6 SP No.2
- WEBS**
2x4 SP No.2 *Except*
3-18,13-7,11-7,11-9,19-2:2x4 SP No.3
Right: 2x4 SP No.3
- WEDGE**
Right: 2x4 SP No.3
- BRACING**
- TOP CHORD Structural wood sheathing directly applied or 2-11-15 oc purlins, except end verticals, and 2-0-0 oc purlins (4-0-0 max.): 4-6.
- BOT CHORD Rigid ceiling directly applied or 10-0-0 oc bracing, Except:
2-2-0 oc bracing: 11-13.
- WEBS**
1 Row at midpt 3-16, 5-15, 6-15, 7-13
- REACTIONS** (size) 10= Mechanical, 19=0-5-8
Max Horiz 19=-186 (LC 12)
Max Uplift 10=-229 (LC 15), 19=-217 (LC 14)
Max Grav 10=2417 (LC 45), 19=2489 (LC 45)
- FORCES** (lb) - Maximum Compression/Maximum Tension
- TOP CHORD 1-2=0/27, 2-4=-3171/454, 4-5=-2881/487,
5-6=-2881/487, 6-7=-3302/481,
7-9=-4195/470, 9-10=-4436/476,
2-19=-2347/332
- BOT CHORD 18-19=-120/224, 16-18=-249/2758,
15-16=-106/2571, 13-15=-119/2822,
11-13=-245/3448, 10-11=-340/3872
- WEBS**
3-18=-476/167, 3-16=-406/182,
4-16=-24/548, 4-15=-152/710,
5-15=-689/196, 6-15=-218/345,
6-13=-87/1130, 7-13=-977/259,
7-11=-20/642, 9-11=-333/217,
2-18=-177/2763
- NOTES**
- Unbalanced roof live loads have been considered for this design.
 - Wind: ASCE 7-16; Vult=130mph (3-second gust)
Vasd=103mph; TC DL=6.0psf; BC DL=6.0psf; h=25ft;
Cat. II; Exp B; Enclosed; MWFRS (envelope) exterior zone and C-C Exterior(2E) -0-10-8 to 4-5-5, Interior (1) 4-5-5 to 10-1-12, Exterior(2R) 10-1-12 to 38-11-4, Interior (1) 38-11-4 to 47-10-3, Exterior(2E) 47-10-3 to 53-2-0 zone; cantilever left and right exposed; end vertical left and right exposed; C-C for members and forces & MWFRS for reactions shown; Lumber DOL=1.60 plate grip DOL=1.60
 - TCLL: ASCE 7-16; Pr=20.0 psf (roof LL: Lum DOL=1.15 Plate DOL=1.15); Pf=20.0 psf (Lum DOL=1.15 Plate DOL=1.15); Is=1.0; Rough Cat B; Fully Exp.; Ce=0.9; Cs=1.00; Ct=1.10
 - Unbalanced snow loads have been considered for this design.
 - This truss has been designed for greater of min roof live load of 12.0 psf or 1.00 times flat roof load of 20.0 psf on overhangs non-concurrent with other live loads.
 - Provide adequate drainage to prevent water ponding.
 - This truss has been designed for a 10.0 psf bottom chord live load nonconcurrent with any other live loads.
 - * This truss has been designed for a live load of 20.0psf on the bottom chord in all areas where a rectangle 3-06-00 tall by 2-00-00 wide will fit between the bottom chord and any other members, with BCDL = 10.0psf.
 - Refer to girder(s) for truss to truss connections.
 - Provide mechanical connection (by others) of truss to bearing plate capable of withstanding 229 lb uplift at joint 10.
 - One H2.5A Simpson Strong-Tie connectors recommended to connect truss to bearing walls due to UPLIFT at jt(s) 19. This connection is for uplift only and does not consider lateral forces.
 - This truss is designed in accordance with the 2018 International Residential Code sections R502.11.1 and R802.10.2 and referenced standard ANSI/TPI 1.
 - Graphical purlin representation does not depict the size or the orientation of the purlin along the top and/or bottom chord.
- LOAD CASE(S)** Standard



April 14, 2023

WARNING - Verify design parameters and READ NOTES ON THIS AND INCLUDED MITEK REFERENCE PAGE MII-7473 rev. 5/19/2020 BEFORE USE.

Design valid for use only with MiTek® connectors. This design is based only upon parameters shown, and is for an individual building component, not a truss system. Before use, the building designer must verify the applicability of design parameters and properly incorporate this design into the overall building design. Bracing indicated is to prevent buckling of individual truss web and/or chord members only. Additional temporary and permanent bracing is always required for stability and to prevent collapse with possible personal injury and property damage. For general guidance regarding the fabrication, storage, delivery, erection and bracing of trusses and truss systems, see **ANSI/TPI1 Quality Criteria, DSB-89 and BCSI Building Component Safety Information** available from Truss Plate Institute, 2670 Crain Highway, Suite 203 Waldorf, MD 20601



818 Soundside Road
Edenton, NC 27932

Job 23040053-01	Truss A1GE	Truss Type Piggyback Base Supported Gable	Qty 1	Ply 1	David Weekly-11 Serenity-Roof-B326 A Job Reference (optional)	I57767103
--------------------	---------------	--	----------	----------	--	-----------

Carter Components (Sanford), Sanford, NC - 27332,

Run: 8.53 S Mar 9 2023 Print: 8.530 S Mar 9 2023 MiTek Industries, Inc. Thu Apr 13 16:16:28
ID:HvYYHe4LpHmiz2Dld9nw5TzRQov-RfC?PsB70Hq3NSgPqnL8w3uITXbGKwKRCDoi7J4zJC?f

Page: 1

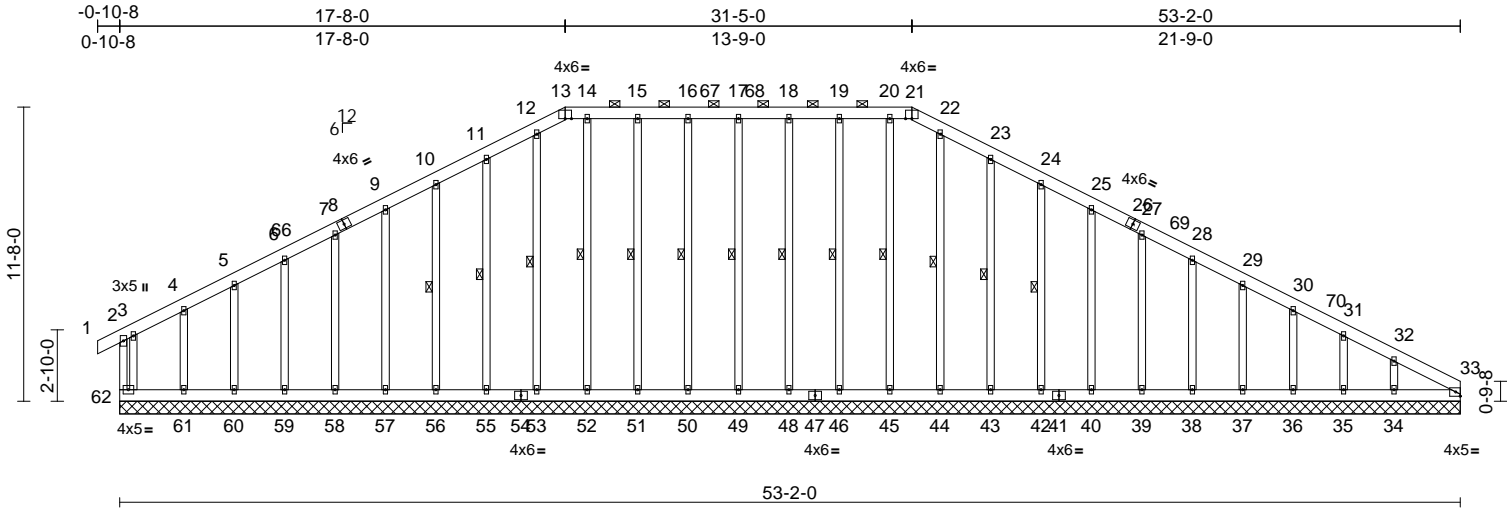

Scale = 1:91.4

Loading	(psf)	Spacing	2-0-0	CSI	DEFL	in	(loc)	l/defl	L/d	PLATES	GRIP	
TCLL (roof)	20.0	Plate Grip DOL	1.15	TC	0.17	Vert(LL)	n/a	-	n/a	999	MT20	244/190
Snow (Pf)	20.0	Lumber DOL	1.15	BC	0.05	Vert(CT)	n/a	-	n/a	999		
TCDL	10.0	Rep Stress Incr	YES	WB	0.21	Horz(CT)	0.01	33	n/a	n/a		
BCLL	0.0*	Code	IRC2018/TPI2014	Matrix-MSH								
BCDL	10.0											
											Weight: 545 lb	FT = 20%

LUMBER		Max Uplift		TOP CHORD	
TOP CHORD	2x6 SP No.2	33=36 (LC 14), 34=96 (LC 15), 35=28 (LC 15), 36=47 (LC 15), 37=43 (LC 15), 38=44 (LC 15), 39=44 (LC 15), 40=43 (LC 15), 42=46 (LC 15), 43=51 (LC 15), 46=29 (LC 11), 48=28 (LC 11), 49=25 (LC 10), 50=28 (LC 11), 51=28 (LC 10), 55=53 (LC 14), 56=46 (LC 14), 57=43 (LC 14), 58=44 (LC 14), 59=45 (LC 14), 60=27 (LC 14), 61=115 (LC 14), 62=34 (LC 15), 63=36 (LC 14)		2-62=136/271, 1-2=0/27, 2-3=64/144, 3-4=72/65, 4-5=59/152, 5-6=73/202, 6-7=88/247, 7-9=104/292, 9-10=120/337, 10-11=136/384, 11-12=155/434, 12-13=156/427, 13-14=149/422, 14-15=149/422, 15-16=149/422, 16-17=149/422, 17-18=149/422, 18-19=149/422, 19-20=149/422, 20-21=149/422, 21-22=156/427, 22-23=155/434, 23-24=136/384, 24-25=120/337, 25-27=104/292, 27-28=88/247, 28-29=92/202, 29-30=106/157, 30-31=119/129, 31-32=140/107, 32-33=184/114	
BOT CHORD	2x6 SP No.2	33=134 (LC 27), 34=217 (LC 55), 35=143 (LC 1), 36=164 (LC 43), 37=159 (LC 1), 38=172 (LC 43), 39=221 (LC 43), 40=230 (LC 43), 42=229 (LC 43), 43=231 (LC 43), 44=211 (LC 43), 45=192 (LC 38), 46=220 (LC 38), 48=218 (LC 38), 49=216 (LC 38), 50=218 (LC 38), 51=220 (LC 38), 52=192 (LC 38), 53=214 (LC 41), 55=235 (LC 41), 56=233 (LC 41), 57=233 (LC 41), 58=232 (LC 41), 59=188 (LC 41), 60=159 (LC 1), 61=179 (LC 47), 62=177 (LC 1), 63=134 (LC 27)			
WEBS	2x4 SP No.3				
OTHERS	2x4 SP No.3 *Except* 49-17,48-18,46-19,45-20,44-22,50-16,51-15, 52-14,53-12:2x4 SP No.2				
BRACING		Max Grav			
TOP CHORD	Structural wood sheathing directly applied or 6-0-0 oc purlins, except end verticals, and 2-0-0 oc purlins (6-0-0 max.): 13-21.				
BOT CHORD	Rigid ceiling directly applied or 10-0-0 oc bracing.				
WEBS	1 Row at midpt 17-49, 18-48, 19-46, 20-45, 22-44, 23-43, 24-42, 16-50, 15-51, 14-52, 12-53, 11-55, 10-56				
REACTIONS (size)					
	33=53-2-0, 34=53-2-0, 35=53-2-0, 36=53-2-0, 37=53-2-0, 38=53-2-0, 39=53-2-0, 40=53-2-0, 42=53-2-0, 43=53-2-0, 44=53-2-0, 45=53-2-0, 46=53-2-0, 48=53-2-0, 49=53-2-0, 50=53-2-0, 51=53-2-0, 52=53-2-0, 53=53-2-0, 55=53-2-0, 56=53-2-0, 57=53-2-0, 58=53-2-0, 59=53-2-0, 60=53-2-0, 61=53-2-0, 62=53-2-0, 63=53-2-0				
	Max Horiz 62=186 (LC 12)				
FORCES		(lb) - Maximum Compression/Maximum Tension			

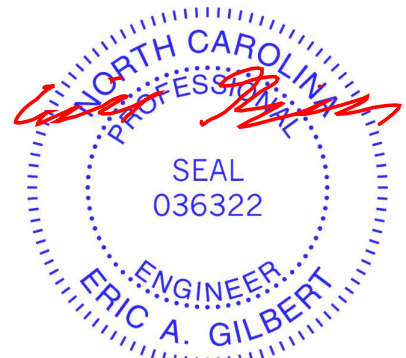

April 14, 2023

Continued on page 2

WARNING - Verify design parameters and READ NOTES ON THIS AND INCLUDED MITEK REFERENCE PAGE MII-7473 rev. 5/19/2020 BEFORE USE.

Design valid for use only with MiTek® connectors. This design is based only upon parameters shown, and is for an individual building component, not a truss system. Before use, the building designer must verify the applicability of design parameters and properly incorporate this design into the overall building design. Bracing indicated is to prevent buckling of individual truss web and/or chord members only. Additional temporary and permanent bracing is always required for stability and to prevent collapse with possible personal injury and property damage. For general guidance regarding the fabrication, storage, delivery, erection and bracing of trusses and truss systems, see **ANSI/TPI1 Quality Criteria, DSB-89 and BCSI Building Component Safety Information** available from Truss Plate Institute, 2670 Crain Highway, Suite 203 Waldorf, MD 20601



818 Soundside Road
Edenton, NC 27932

Job	Truss	Truss Type	Qty	Ply	David Weekly-11 Serenity-Roof-B326 A
23040053-01	A1GE	Piggyback Base Supported Gable	1	1	I57767103 Job Reference (optional)

Carter Components (Sanford), Sanford, NC - 27332,

Run: 8.53 S Mar 9 2023 Print: 8.530 S Mar 9 2023 MiTek Industries, Inc. Thu Apr 13 16:16:28

Page: 2

ID:HvYYHe4LpHmiz2Dld9nw5TzRQov-RfC?PsB70Hq3NSgPqnL8w3uITXbGKWRcDoi7J4zJC?

BOT CHORD 61-62=-87/181, 60-61=-87/181,
59-60=-87/181, 58-59=-87/181,
57-58=-87/181, 56-57=-87/181,
55-56=-87/181, 53-55=-87/181,
52-53=-87/181, 51-52=-87/181,
50-51=-87/181, 49-50=-87/181,
48-49=-87/181, 46-48=-87/181,
45-46=-87/181, 44-45=-87/181,
43-44=-87/181, 42-43=-87/181,
40-42=-87/181, 39-40=-87/181,
38-39=-87/181, 37-38=-87/181,
36-37=-87/181, 35-36=-87/181,
34-35=-87/181, 33-34=-87/181

WEBS 17-49=-176/57, 18-48=-178/62,
19-46=-180/61, 20-45=-152/14,
22-44=-171/10, 23-43=-191/89,
24-42=-189/81, 25-40=-190/77,
27-39=-181/77, 28-38=-132/77,
29-37=-120/77, 30-36=-121/80,
31-35=-113/104, 32-34=-149/151,
16-50=-178/62, 15-51=-180/61,
14-52=-152/8, 12-53=-174/0, 11-55=-195/89,
10-56=-193/81, 9-57=-193/77, 7-58=-192/77,
6-59=-148/77, 5-60=-122/87, 4-61=-119/177,
3-62=-179/99

NOTES

- 1) Unbalanced roof live loads have been considered for this design.
- 2) Wind: ASCE 7-16; Vult=130mph (3-second gust)
Vasd=103mph; TC DL=6.0psf; BCDL=6.0psf; h=25ft;
Cat. II; Exp B; Enclosed; MWFRS (envelope) exterior zone and C-C Corner(3E) -0-10-8 to 4-6-8, Exterior(2N) 4-6-8 to 12-4-3, Corner(3R) 12-4-3 to 22-11-13, Exterior (2N) 22-11-13 to 26-1-3, Corner(3R) 26-1-3 to 36-6-8, Exterior(2N) 36-6-8 to 47-10-3, Corner(3E) 47-10-3 to 53-2-0 zone; cantilever left and right exposed ; end vertical left and right exposed;C-C for members and forces & MWFRS for reactions shown; Lumber DOL=1.60 plate grip DOL=1.60
- 3) Truss designed for wind loads in the plane of the truss only. For studs exposed to wind (normal to the face), see Standard Industry Gable End Details as applicable, or consult qualified building designer as per ANSI/TPI 1.
- 4) TC LL: ASCE 7-16; Pr=20.0 psf (roof LL: Lum DOL=1.15 Plate DOL=1.15); Pf=20.0 psf (Lum DOL=1.15 Plate DOL=1.15); Is=1.0; Rough Cat B; Fully Exp.; Ce=0.9; Cs=1.00; Ct=1.10
- 5) Unbalanced snow loads have been considered for this design.
- 6) This truss has been designed for greater of min roof live load of 12.0 psf or 1.00 times flat roof load of 20.0 psf on overhangs non-concurrent with other live loads.
- 7) Provide adequate drainage to prevent water ponding.
- 8) All plates are 2x4 MT20 unless otherwise indicated.
- 9) Gable requires continuous bottom chord bearing.
- 10) Gable studs spaced at 2-0-0 oc.
- 11) This truss has been designed for a 10.0 psf bottom chord live load nonconcurrent with any other live loads.
- 12) * This truss has been designed for a live load of 20.0psf on the bottom chord in all areas where a rectangle 3-06-00 tall by 2-00-00 wide will fit between the bottom chord and any other members.
- 13) N/A

- 14) This truss is designed in accordance with the 2018 International Residential Code sections R502.11.1 and R802.10.2 and referenced standard ANSI/TPI 1.
- 15) Graphical purlin representation does not depict the size or the orientation of the purlin along the top and/or bottom chord.

LOAD CASE(S) Standard

WARNING - Verify design parameters and READ NOTES ON THIS AND INCLUDED MITEK REFERENCE PAGE MII-7473 rev. 5/19/2020 BEFORE USE.

Design valid for use only with MiTek® connectors. This design is based only upon parameters shown, and is for an individual building component, not a truss system. Before use, the building designer must verify the applicability of design parameters and properly incorporate this design into the overall building design. Bracing indicated is to prevent buckling of individual truss web and/or chord members only. Additional temporary and permanent bracing is always required for stability and to prevent collapse with possible personal injury and property damage. For general guidance regarding the fabrication, storage, delivery, erection and bracing of trusses and truss systems, see

ANSI/TPI1 Quality Criteria, DSB-89 and BCSI Building Component

Safety Information available from Truss Plate Institute, 2670 Crain Highway, Suite 203 Waldorf, MD 20601

ENGINEERING BY
TRENCO
A MiTek Affiliate

818 Soundside Road
Edenton, NC 27932

Job 23040053-01	Truss A1T	Truss Type Piggyback Base	Qty 3	Ply 1	David Weekly-11 Serenity-Roof-B326 A Job Reference (optional)	I5767104
--------------------	--------------	------------------------------	----------	----------	--	----------

Carter Components (Sanford), Sanford, NC - 27332,

Run: 8.53 S Mar 9 2023 Print: 8.530 S Mar 9 2023 MiTek Industries, Inc. Thu Apr 13 16:16:31

Page: 1

ID:OFJF3IDTxFbWwzRbXohbzzRCTM-RfC?PsB70Hq3NSgPqnL8w3uITXbGKwCDoi7J4zJC7f

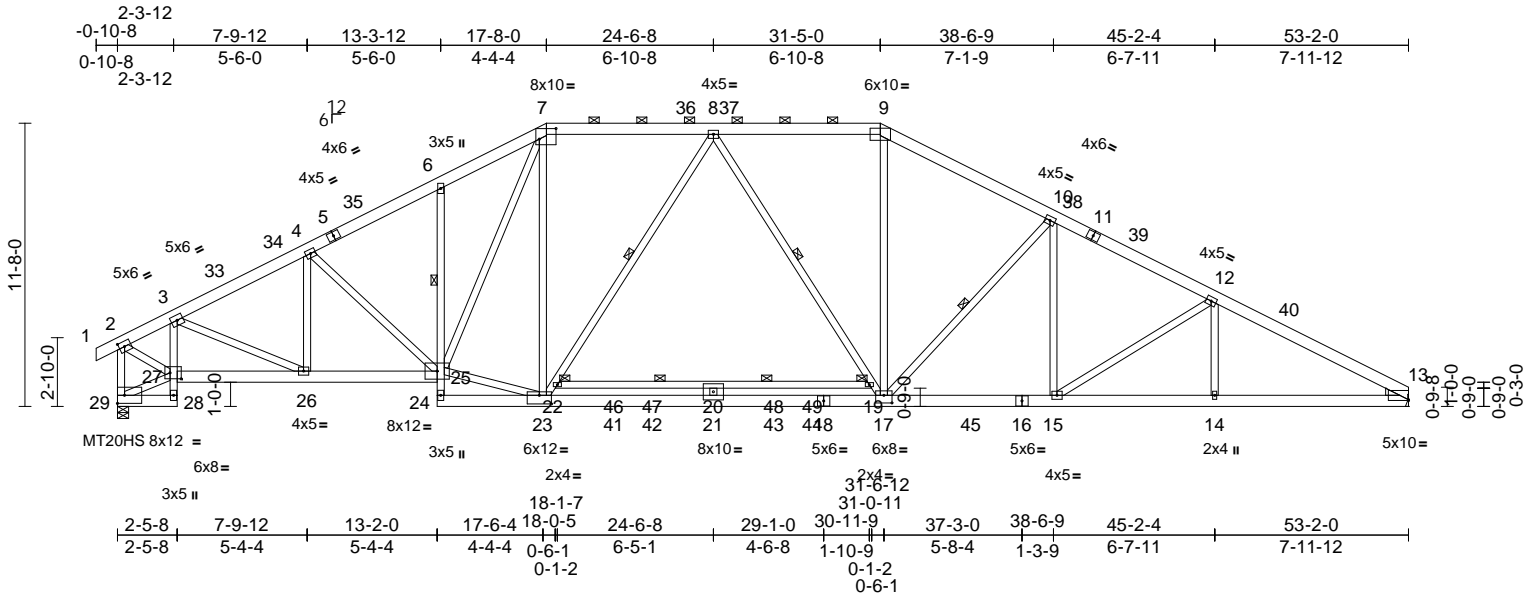

Scale = 1:94.9

Plate Offsets (X, Y): [2:0-2-11,0-2-8], [7:0-8-4,0-5-4], [13:Edge,0-0-7], [17:0-4-0,0-3-12], [23:0-6-0,0-4-4], [27:0-5-8,0-3-0]

Loading	(psf)	Spacing	2-0-0	CSI	DEFL	in	(loc)	l/defl	L/d	PLATES	GRIP	
TCLL (roof)	20.0	Plate Grip DOL	1.15	TC	0.64	Vert(LL)	-0.65	19-20	>982	240	MT20	244/190
Snow (Pf)	20.0	Lumber DOL	1.15	BC	0.89	Vert(CT)	-1.25	19-20	>509	180	MT20HS	187/143
TCDL	10.0	Rep Stress Incr	YES	WB	0.81	Horz(CT)	0.20	13	n/a	n/a		
BCLL	0.0*	Code	IRC2018/TPI2014	Matrix-MSH								
BCDL	10.0											
											Weight: 469 lb	FT = 20%

LUMBER
TOP CHORD 2x6 SP No.2
BOT CHORD 2x6 SP 2400F 2.0E *Except*
29-28,27-25:2x6 SP No.2, 28-3,6-24:2x4 SP No.3, 22-19:2x4 SP No.2
WEBS 2x4 SP No.3 *Except*
23-7,23-25,25-7,17-9,23-8,2-27,17-8:2x4 SP No.2
WEDGE Right: 2x4 SP No.3
BRACING
TOP CHORD Structural wood sheathing directly applied or 2-7-4 oc purlins, except end verticals, and 2-0-0 oc purlins (3-7-9 max.): 7-9.
BOT CHORD Rigid ceiling directly applied or 6-0-0 oc bracing. Except:
1 Row at midpt 6-25
6-0-0 oc bracing: 19-22
WEBS 1 Row at midpt 8-22, 8-19, 10-17
REACTIONS (size) 13= Mechanical, 29=0-5-8
Max Horiz 29=186 (LC 12)
Max Uplift 13=64 (LC 15), 29=24 (LC 14)
Max Grav 13=2744 (LC 45), 29=2856 (LC 45)
FORCES (lb) - Maximum Compression/Maximum Tension
TOP CHORD 1-2=0/27, 2-3=-2688/92, 3-4=-4140/93, 4-6=-4183/106, 6-7=-4172/194, 7-8=-3268/106, 8-9=-3550/116, 9-10=-4121/81, 10-12=-4618/140, 12-13=-5100/109, 2-29=-2791/108
BOT CHORD 28-29=-18/62, 27-28=0/37, 3-27=-1359/41, 26-27=-131/2420, 25-26=-6/3654, 24-25=-322/0, 6-25=-491/160, 23-24=-74/131, 21-23=0/3567, 17-21=0/3567, 15-17=0/4093, 14-15=-9/4457, 13-14=-57/4457, 20-22=-62/0, 19-20=-62/0

WEBS
4-26=-357/47, 7-23=0/938, 23-25=0/3298, 7-25=-315/1132, 20-21=-384/0, 9-17=0/1475, 10-15=-102/319, 12-14=0/242, 4-25=-143/225, 3-26=0/1357, 22-23=-721/147, 8-22=-623/195, 27-29=-129/198, 2-27=-41/2782, 8-19=-273/306, 17-19=-338/235, 10-17=-911/320, 12-15=-470/164

- NOTES**
- Unbalanced roof live loads have been considered for this design.
 - Wind: ASCE 7-16; Vult=130mph (3-second gust) Vasd=103mph; TCDL=6.0psf; BCDL=6.0psf; h=25ft; Cat. II; Exp B; Enclosed; MWFRS (envelope) exterior zone and C-C Exterior(2E) 0-10-8 to 4-5-5, Interior (1) 4-5-5 to 10-1-12, Exterior(2R) 10-1-12 to 38-11-4, Interior (1) 38-11-4 to 47-10-3, Exterior(2E) 47-10-3 to 53-2-0 zone; cantilever left and right exposed ; end vertical left and right exposed;C-C for members and forces & MWFRS for reactions shown; Lumber DOL=1.60 plate grip DOL=1.60
 - TCLL: ASCE 7-16; Pr=20.0 psf (roof LL: Lum DOL=1.15 Plate DOL=1.15); Pf=20.0 psf (Lum DOL=1.15 Plate DOL=1.15); Is=1.0; Rough Cat B; Fully Exp.; Ce=0.9; Cs=1.00; Ct=1.10
 - Unbalanced snow loads have been considered for this design.
 - This truss has been designed for greater of min roof live load of 12.0 psf or 1.00 times flat roof load of 20.0 psf on overhangs non-concurrent with other live loads.
 - 200.0lb AC unit load placed on the bottom chord, 24-6-8 from left end, supported at two points, 5-0-0 apart.
 - Provide adequate drainage to prevent water ponding.
 - All plates are MT20 plates unless otherwise indicated.
 - This truss has been designed for a 10.0 psf bottom chord live load nonconcurrent with any other live loads.

- * This truss has been designed for a live load of 20.0psf on the bottom chord in all areas where a rectangle 3-06-00 tall by 2-00-00 wide will fit between the bottom chord and any other members, with BCDL = 10.0psf.
- Refer to girder(s) for truss to truss connections.
- Provide mechanical connection (by others) of truss to bearing plate capable of withstanding 64 lb uplift at joint 13.
- One H2.5A Simpson Strong-Tie connectors recommended to connect truss to bearing walls due to UPLIFT at jt(s) 29. This connection is for uplift only and does not consider lateral forces.
- This truss is designed in accordance with the 2018 International Residential Code sections R502.11.1 and R802.10.2 and referenced standard ANSI/TPI 1.
- Graphical purlin representation does not depict the size or the orientation of the purlin along the top and/or bottom chord.

LOAD CASE(S) Standard

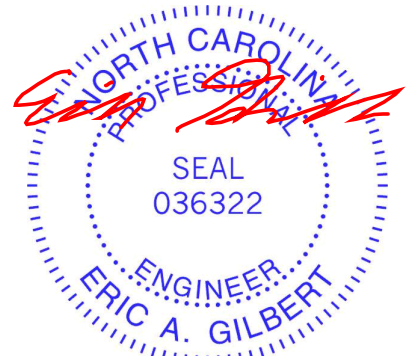

April 14, 2023

WARNING - Verify design parameters and READ NOTES ON THIS AND INCLUDED MITEK REFERENCE PAGE MII-7473 rev. 5/19/2020 BEFORE USE.

Design valid for use only with MiTek® connectors. This design is based only upon parameters shown, and is for an individual building component, not a truss system. Before use, the building designer must verify the applicability of design parameters and properly incorporate this design into the overall building design. Bracing indicated is to prevent buckling of individual truss web and/or chord members only. Additional temporary and permanent bracing is always required for stability and to prevent collapse with possible personal injury and property damage. For general guidance regarding the fabrication, storage, delivery, erection and bracing of trusses and truss systems, see ANSITPI Quality Criteria, DSB-89 and BCSI Building Component Safety Information available from Truss Plate Institute, 2670 Crain Highway, Suite 203 Waldorf, MD 20601



818 Soundside Road
Edenton, NC 27932

Job 23040053-01	Truss A2	Truss Type Piggyback Base	Qty 1	Ply 1	David Weekly-11 Serenity-Roof-B326 A Job Reference (optional)	I57767105
--------------------	-------------	------------------------------	----------	----------	--	-----------

Carter Components (Sanford), Sanford, NC - 27332,

Run: 8.53 S Mar 9 2023 Print: 8.530 S Mar 9 2023 MiTek Industries, Inc. Thu Apr 13 16:16:33
ID:DGN6a6f8caCKWpHw1clz1BzRCZx-RfC?PsB70Hq3NSgPqnl8w3ulTXbGKWCDoi7J4zJC?f

Page: 1

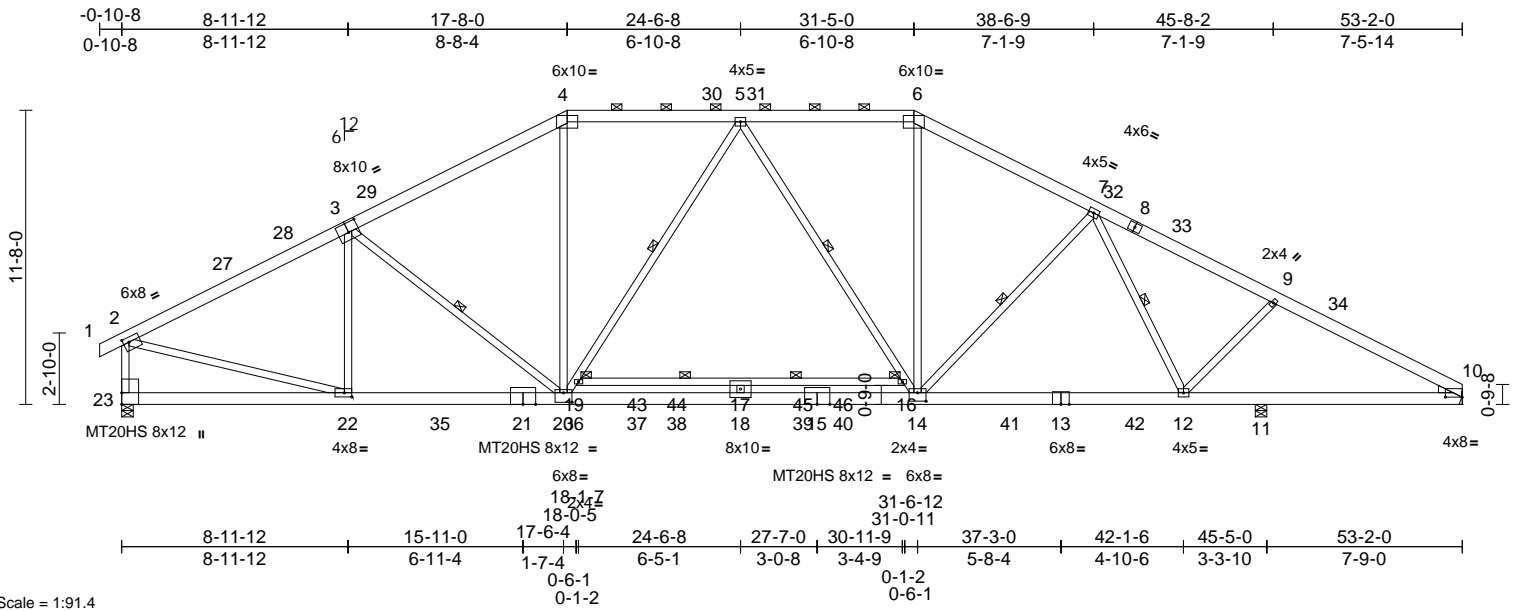

Plate Offsets (X, Y): [2:0-2-12,0-2-4], [3:0-5-0,0-4-8], [10:0-8-0,0-0-1], [14:0-4-0,0-4-0], [20:0-4-0,0-4-8], [22:0-3-8,0-2-0]

Loading	(psf)	Spacing	2-0-0	CSI	DEFL	in	(loc)	l/defl	L/d	PLATES	GRIP	
TCLL (roof)	20.0	Plate Grip DOL	1.15	TC	0.98	Vert(LL)	-0.65	16-17	>832	240	MT20	244/190
Snow (Pf)	20.0	Lumber DOL	1.15	BC	0.91	Vert(CT)	-1.24	16-17	>436	180	MT20HS	187/143
TCDL	10.0	Rep Stress Incr	YES	WB	0.76	Horz(CT)	0.12	10	n/a	n/a		
BCLL	0.0*	Code	IRC2018/TPI2014	Matrix-MSH								
BCDL	10.0											
											Weight: 428 lb	FT = 20%

LUMBER	
TOP CHORD	2x6 SP No.2
BOT CHORD	2x6 SP 2400F 2.0E *Except* 16-19:2x4 SP No.2
WEBS	2x4 SP No.3 *Except* 20-4,14-6,14-5,22-2,20-5,20-3:2x4 SP No.2 Right: 2x4 SP No.3
WEDGE	
BRACING	
TOP CHORD	Structural wood sheathing directly applied or 2-5-14 oc purlins, except end verticals, and 2-0-0 oc purlins (3-8-14 max.): 4-6.
BOT CHORD	Rigid ceiling directly applied or 9-4-10 oc bracing. Except: 6-0-0 oc bracing: 16-19
WEBS	1 Row at midpt 5-16, 5-19, 7-14, 7-12, 3-20
REACTIONS	(size)
	10= Mechanical, 11=0-5-8, 23=0-5-8
	Max Horiz 23=-186 (LC 12)
	Max Uplift 10=-124 (LC 15), 23=-40 (LC 14)
	Max Grav 10=2084 (LC 45), 11=810 (LC 45), 23=2783 (LC 45)
FORCES	(lb) - Maximum Compression/Maximum Tension
TOP CHORD	1-2=0/27, 2-4=-3652/132, 4-5=-3111/131, 5-6=-3263/144, 6-7=-3800/114, 7-9=-3773/234, 9-10=-3996/242, 2-23=-2610/163
BOT CHORD	22-23=-112/244, 20-22=-39/3097, 18-20=0/3346, 14-18=0/3346, 12-14=0/3483, 11-12=-133/3458, 10-11=-133/3458, 17-19=-64/0, 16-17=-64/0

WEBS	
	3-22=-634/33, 4-20=0/1211, 17-18=-382/0, 6-14=0/1341, 5-16=-339/212, 14-16=-406/147, 2-22=0/3098, 19-20=-611/148, 5-19=-538/198, 7-14=-543/349, 7-12=-395/0, 9-12=-287/225, 3-20=-259/418

- NOTES**
- Unbalanced roof live loads have been considered for this design.
 - Wind: ASCE 7-16; Vult=130mph (3-second gust) Vasd=103mph; TCCL=6.0psf; BCDL=6.0psf; h=25ft; Cat. II; Exp B; Enclosed; MWFRS (envelope) exterior zone and C-C Exterior(2E) -0-10-8 to 4-5-5, Interior (1) 4-5-5 to 10-1-12, Exterior(2R) 10-1-12 to 38-11-4, Interior (1) 38-11-4 to 47-10-3, Exterior(2E) 47-10-3 to 53-2-0 zone; cantilever left and right exposed; end vertical left and right exposed; C-C for members and forces & MWFRS for reactions shown; Lumber DOL=1.60 plate grip DOL=1.60
 - TCLL: ASCE 7-16; Pr=20.0 psf (roof LL: Lum DOL=1.15 Plate DOL=1.15); Pf=20.0 psf (Lum DOL=1.15 Plate DOL=1.15); Is=1.0; Rough Cat B; Fully Exp.; Ce=0.9; Cs=1.00; Ct=1.10
 - Unbalanced snow loads have been considered for this design.
 - This truss has been designed for greater of min roof live load of 12.0 psf or 1.00 times flat roof load of 20.0 psf on overhangs non-concurrent with other live loads.
 - 200.0lb AC unit load placed on the bottom chord, 24-6-8 from left end, supported at two points, 5-0-0 apart.
 - Provide adequate drainage to prevent water ponding.
 - All plates are MT20 plates unless otherwise indicated.
 - This truss has been designed for a 10.0 psf bottom chord live load nonconcurrent with any other live loads.

- * This truss has been designed for a live load of 20.0psf on the bottom chord in all areas where a rectangle 3-06-00 tall by 2-00-00 wide will fit between the bottom chord and any other members, with BCDL = 10.0psf.
- Refer to girder(s) for truss to truss connections.
- Provide mechanical connection (by others) of truss to bearing plate capable of withstanding 124 lb uplift at joint 10.
- One H2.5A Simpson Strong-Tie connectors recommended to connect truss to bearing walls due to UPLIFT at jt(s) 23. This connection is for uplift only and does not consider lateral forces.
- This truss is designed in accordance with the 2018 International Residential Code sections R502.11.1 and R802.10.2 and referenced standard ANSI/TPI 1.
- Graphical purlin representation does not depict the size or the orientation of the purlin along the top and/or bottom chord.

LOAD CASE(S) Standard

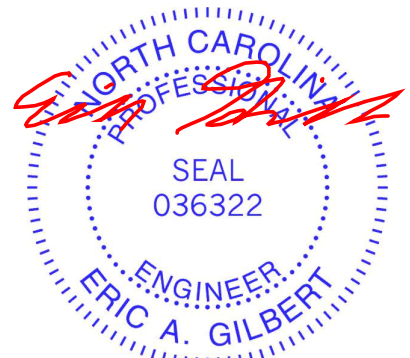

April 14, 2023

WARNING - Verify design parameters and READ NOTES ON THIS AND INCLUDED MITEK REFERENCE PAGE MII-7473 rev. 5/19/2020 BEFORE USE.

Design valid for use only with MiTek® connectors. This design is based only upon parameters shown, and is for an individual building component, not a truss system. Before use, the building designer must verify the applicability of design parameters and properly incorporate this design into the overall building design. Bracing indicated is to prevent buckling of individual truss web and/or chord members only. Additional temporary and permanent bracing is always required for stability and to prevent collapse with possible personal injury and property damage. For general guidance regarding the fabrication, storage, delivery, erection and bracing of trusses and truss systems, see **ANSI/TPI Quality Criteria, DSB-89 and BCSI Building Component Safety Information** available from Truss Plate Institute, 2670 Crain Highway, Suite 203 Waldorf, MD 20601



818 Soundside Road
Edenton, NC 27932

Job 23040053-01	Truss A2GR	Truss Type Attic Girder	Qty 1	Ply 4	David Weekly-11 Serenity-Roof-B326 A Job Reference (optional)	I57767106
--------------------	---------------	----------------------------	----------	----------	--	-----------

Carter Components (Sanford), Sanford, NC - 27332,

Run: 8.53 S Mar 9 2023 Print: 8.530 S Mar 9 2023 MiTek Industries, Inc. Thu Apr 13 16:16:35
ID:VIY0g5gMUgWQZRYxiBXlyTRA_fRfC?PsB70Hq3NSgPqnL8w3uTXbGKwRcDoi7J4zJC?f

Page: 1

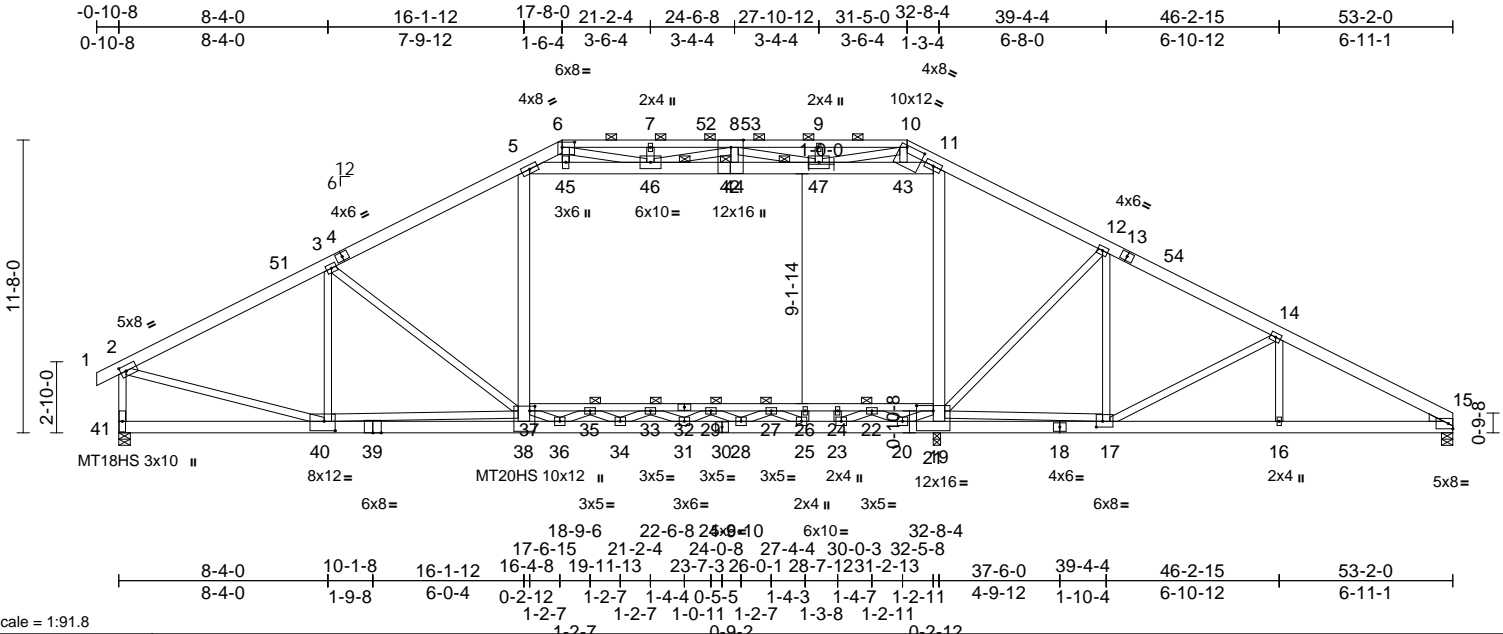

Plate Offsets (X, Y): [2:0-2-11,0-2-8], [6:0-6-0,0-2-8], [10:0-9-0,0-1-0], [17:0-3-0,0-2-12], [21:0-8-0,0-2-8], [38:0-2-4,0-2-8], [40:0-5-4,0-4-8], [42:Edge,0-5-14]

Loading	(psf)	Spacing	2-0-0	CSI	DEFL	in (loc)	l/defl	L/d	PLATES	GRIP		
TCLL (roof)	20.0	Plate Grip DOL	1.15	TC	0.77	Vert(LL)	-0.41	38-40	>957	240	MT20	244/190
Snow (Pf)	20.0	Lumber DOL	1.15	BC	0.90	Vert(CT)	-0.63	38-40	>624	180	MT18HS	244/190
TCDL	10.0	Rep Stress Incr	NO	WB	0.98	Horz(CT)	0.11	15	n/a	n/a	MT20HS	187/143
BCLL	0.0*	Code	IRC2018/TPI2014	Matrix-MSH		Attic	0.20	21-37	>966	360		
BCDL	10.0											
											Weight: 2022 lb	FT = 20%

LUMBER
TOP CHORD 2x6 SP No.2 *Except* 6-10:2x4 SP No.2
BOT CHORD 2x6 SP 2400F 2.0E *Except* 37-32:2x4 SP No.2, 39-41:2x6 SP No.2, 32-21:2x4 SP No.1
WEBS 2x4 SP No.3 *Except* 5-38,11-19,42-11,42-5:2x6 SP No.2, 40-2,21-17:2x4 SP No.2
WEDGE Right: 2x4 SP No.3
BRACING
TOP CHORD Structural wood sheathing directly applied or 6-0-0 oc purlins, except end verticals, and 2-0-0 oc purlins (6-0-0 max.): 6-10.
BOT CHORD Rigid ceiling directly applied or 10-0-0 oc bracing, Except: 6-0-0 oc bracing: 19-20.
JOINTS 1 Brace at Jt(s): 44, 22, 35, 33, 29, 27, 46, 47
REACTIONS (size) 15=0-5-8, 19=0-3-8, 41=0-5-8
 Max Horiz 41=187 (LC 10)
 Max Uplift 15=487 (LC 12), 19=4368 (LC 45), 41=801 (LC 12)
 Max Grav 15=8420 (LC 46), 19=730 (LC 12), 41=11643 (LC 46)
FORCES (lb) - Maximum Compression/Maximum Tension
TOP CHORD 1-2=0/27, 2-3=15926/1083, 3-5=18710/1246, 5-6=4813/431, 6-7=4430/589, 7-8=4430/589, 8-9=4126/579, 9-10=4126/579, 10-11=4764/441, 11-12=18311/1271, 12-14=17079/1149, 14-15=16640/1026, 2-41=11588/842

BOT CHORD 35-37=-1421/326, 33-35=-547/65, 29-33=-790/1300, 27-29=-993/3233, 26-27=-972/7325, 24-26=-972/7325, 22-24=-972/7325, 21-22=-738/14507, 40-41=-122/280, 38-40=-1510/17949, 36-38=-1464/16559, 34-36=-912/17653, 31-34=-388/16407, 28-31=-61/14734, 25-28=0/11725, 23-25=0/9387, 20-23=-83/5677, 19-20=-615/268, 17-19=-513/2597, 16-17=-857/14697, 15-16=-857/14697
WEBS 3-40=3516/290, 37-38=-622/8715, 5-37=-447/8037, 19-21=-658/5998, 11-21=-564/7508, 12-17=-1855/161, 14-16=-484/124, 5-45=-12501/833, 45-46=12240/814, 44-46=-12032/611, 44-47=-12032/611, 43-47=-12905/896, 11-43=-13584/943, 2-40=-896/14649, 10-43=-202/2961, 8-44=-38/761, 14-17=-138/822, 6-45=-108/1500, 23-24=-1152/27, 25-26=0/224, 20-21=0/2876, 20-22=-4113/0, 22-23=0/4309, 36-37=0/1941, 35-36=-450/575, 34-35=-898/348, 33-34=-281/593, 31-33=-1074/225, 29-31=-166/933, 28-29=-1473/111, 27-28=-40/2129, 25-27=-2710/0, 17-21=-404/12845, 12-21=-157/1781, 7-46=200/140, 6-46=-1311/501, 8-46=-1878/224, 9-47=-220/104, 10-47=-907/793, 8-47=-2150/252, 37-40=-3527/553, 3-37=-170/3015

NOTES

- 4-ply truss to be connected together with 10d (0.131"x3") nails as follows:
 Top chords connected as follows: 2x6 - 2 rows staggered at 0-9-0 oc, 2x4 - 1 row at 0-9-0 oc.
 Bottom chords connected as follows: 2x4 - 1 row at 0-5-0 oc, 2x6 - 2 rows staggered at 0-9-0 oc.
 Web connected as follows: 2x4 - 1 row at 0-9-0 oc, 2x6 - 2 rows staggered at 0-4-0 oc, Except member 11-19 2x6 - 2 rows staggered at 0-9-0 oc.
 Attach BC w/ 1/2" diam. bolts (ASTM A-307) in the center of the member w/washers at 4-0-0 oc.
- All loads are considered equally applied to all plies, except if noted as front (F) or back (B) face in the LOAD CASE(S) section. Ply to ply connections have been provided to distribute only loads noted as (F) or (B), unless otherwise indicated.
- Unbalanced roof live loads have been considered for this design.

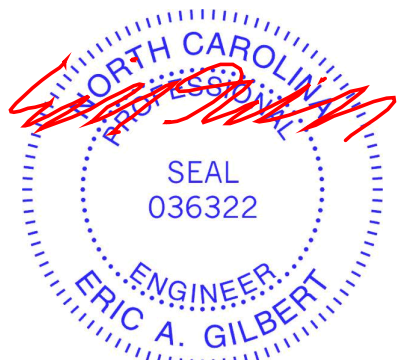

April 14, 2023

Continued on page 2

WARNING - Verify design parameters and READ NOTES ON THIS AND INCLUDED MITEK REFERENCE PAGE MII-7473 rev. 5/19/2020 BEFORE USE.

Design valid for use only with MiTek® connectors. This design is based only upon parameters shown, and is for an individual building component, not a truss system. Before use, the building designer must verify the applicability of design parameters and properly incorporate this design into the overall building design. Bracing indicated is to prevent buckling of individual truss web and/or chord members only. Additional temporary and permanent bracing is always required for stability and to prevent collapse with possible personal injury and property damage. For general guidance regarding the fabrication, storage, delivery, erection and bracing of trusses and truss systems, see **ANSI/TPI1 Quality Criteria, DSB-89 and BCSI Building Component Safety Information** available from Truss Plate Institute, 2670 Crain Highway, Suite 203 Waldorf, MD 20601



818 Soundside Road
Edenton, NC 27932

Job 23040053-01	Truss A2GR	Truss Type Attic Girder	Qty 1	Ply 4	David Weekly-11 Serenity-Roof-B326 A Job Reference (optional)	I57767106
--------------------	---------------	----------------------------	----------	----------	--	-----------

Carter Components (Sanford), Sanford, NC - 27332,

Run: 8.53 S Mar 9 2023 Print: 8.530 S Mar 9 2023 MiTek Industries, Inc. Thu Apr 13 16:16:35
ID:VIY0g5gMUgwQZRyxixBYltzRA_f-RfC?PsB70Hq3NSgPqnL8w3uTXbGKWrCDoi7J4zJC?f

Page: 2

- 4) Wind: ASCE 7-16; Vult=130mph (3-second gust)
Vasd=103mph; TCDL=6.0psf; BCDL=6.0psf; h=25ft;
Cat. II; Exp B; Enclosed; MWFRS (envelope) exterior
zone; cantilever left and right exposed ; end vertical left
and right exposed; Lumber DOL=1.60 plate grip
DOL=1.60
- 5) TCELL: ASCE 7-16; Pr=20.0 psf (roof LL: Lum DOL=1.15
Plate DOL=1.15); Pf=20.0 psf (Lum DOL=1.15 Plate
DOL=1.15); Is=1.0; Rough Cat B; Fully Exp.; Ce=0.9;
Cs=1.00; Ct=1.10
- 6) Unbalanced snow loads have been considered for this
design.
- 7) This truss has been designed for greater of min roof live
load of 12.0 psf or 1.00 times flat roof load of 20.0 psf on
overhangs non-concurrent with other live loads.
- 8) Provide adequate drainage to prevent water ponding.
- 9) All plates are MT20 plates unless otherwise indicated.
- 10) All plates are 4x5 MT20 unless otherwise indicated.
- 11) This truss has been designed for a 10.0 psf bottom
chord live load nonconcurrent with any other live loads.
- 12) * This truss has been designed for a live load of 20.0psf
on the bottom chord in all areas where a rectangle
3-06-00 tall by 2-00-00 wide will fit between the bottom
chord and any other members.
- 13) Ceiling dead load (5.0 psf) on member(s). 5-45, 45-46,
44-46, 44-47, 43-47, 11-43; Wall dead load (5.0psf) on
member(s).5-37, 11-21
- 14) Bottom chord live load (40.0 psf) and additional bottom
chord dead load (5.0 psf) applied only to room. 35-37,
33-35, 29-33, 27-29, 26-27, 24-26, 22-24, 21-22
- 15) Provide mechanical connection (by others) of truss to
bearing plate capable of withstanding 4368 lb uplift at
joint 19.
- 16) LGT4-SDS3 Simpson Strong-Tie connectors
recommended to connect truss to bearing walls due to
UPLIFT at jt(s) 41. This connection is for uplift only and
does not consider lateral forces.
- 17) One H2.5A Simpson Strong-Tie connectors
recommended to connect truss to bearing walls due to
UPLIFT at jt(s) 15. This connection is for uplift only and
does not consider lateral forces.
- 18) This truss is designed in accordance with the 2018
International Residential Code sections R502.11.1 and
R802.10.2 and referenced standard ANSI/TPI 1.
- 19) Graphical purlin representation does not depict the size
or the orientation of the purlin along the top and/or
bottom chord.
- 20) This truss has large uplift reaction(s) from gravity load
case(s). Proper connection is required to secure truss
against upward movement at the bearings. Building
designer must provide for uplift reactions indicated.
- 21) LGT4 Hurricane ties must have four studs in line below
the truss.
- 22) Hanger(s) or other connection device(s) shall be
provided sufficient to support concentrated load(s) 608
lb down and 52 lb up at 28-7-12, and 10004 lb down
and 851 lb up at 16-0-3 on bottom chord. The design/
selection of such connection device(s) is the
responsibility of others.
- 23) Attic room checked for L/360 deflection.

LOAD CASE(S) Standard

- 1) Dead + Snow (balanced): Lumber Increase=1.15, Plate
Increase=1.15
Uniform Loads (lb/ft)
Vert: 1-2=-60, 2-6=-60, 6-10=-60, 10-15=-60,
21-37=-30, 41-48=-20, 5-45=-10, 45-46=-10,
42-46=-10, 42-44=-10, 44-47=-10, 43-47=-10,
11-43=-10
Drag: 5-37=-10, 11-21=-10
Concentrated Loads (lb)
Vert: 38=-5366 (F), 24=-326 (F)

WARNING - Verify design parameters and READ NOTES ON THIS AND INCLUDED MITEK REFERENCE PAGE MII-7473 rev. 5/19/2020 BEFORE USE.

Design valid for use only with MiTek® connectors. This design is based only upon parameters shown, and is for an individual building component, not a truss system. Before use, the building designer must verify the applicability of design parameters and properly incorporate this design into the overall building design. Bracing indicated is to prevent buckling of individual truss web and/or chord members only. Additional temporary and permanent bracing is always required for stability and to prevent collapse with possible personal injury and property damage. For general guidance regarding the fabrication, storage, delivery, erection and bracing of trusses and truss systems, see **ANSI/TPI1 Quality Criteria, DSB-89 and BCSI Building Component Safety Information** available from Truss Plate Institute, 2670 Crain Highway, Suite 203 Waldorf, MD 20601



818 Soundside Road
Edenton, NC 27932

Job 23040053-01	Truss A2T	Truss Type Piggyback Base	Qty 2	Ply 1	David Weekly-11 Serenity-Roof-B326 A Job Reference (optional)	I57767107
--------------------	--------------	------------------------------	----------	----------	--	-----------

Carter Components (Sanford), Sanford, NC - 27332,

Run: 8.53 S Mar 9 2023 Print: 8.530 S Mar 9 2023 MiTek Industries, Inc. Thu Apr 13 16:16:39
ID:KHotXh90RnM3m7uqcDkTzRCUF-RFC?PsB70Hq3NSgPqnL8w3uITXbGKwRcDoi7J4zJC?f

Page: 1

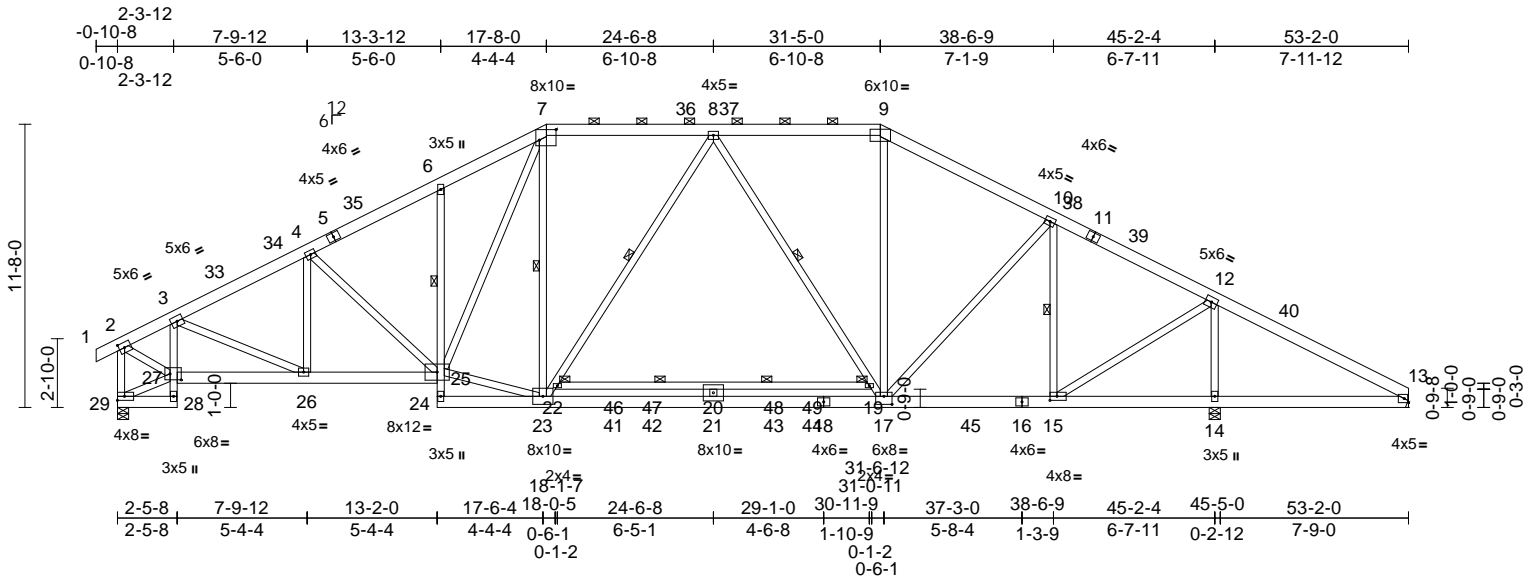

Scale = 1:94.9

Plate Offsets (X, Y): [2:0-2-11,0-2-8], [7:0-8-4,0-5-4], [15:0-3-8,0-2-0], [17:0-4-0,0-4-0], [27:0-5-8,0-3-0]

Loading	(psf)	Spacing	2-0-0	CSI	DEFL	in	(loc)	l/defl	L/d	PLATES	GRIP	
TCLL (roof)	20.0	Plate Grip DOL	1.15	TC	0.46	Vert(LL)	-0.58	20-22	>931	240	MT20	244/190
Snow (Pf)	20.0	Lumber DOL	1.15	BC	0.90	Vert(CT)	-1.09	20-22	>496	180		
TCDL	10.0	Rep Stress Incr	YES	WB	0.96	Horz(CT)	0.11	14	n/a	n/a		
BCLL	0.0*	Code	IRC2018/TPI2014	Matrix-MSH								
BCDL	10.0											
											Weight: 468 lb	FT = 20%

LUMBER
TOP CHORD 2x6 SP No.2
BOT CHORD 2x6 SP 2400F 2.0E *Except*
29-28,27-25:2x6 SP No.2, 28-3,6-24:2x4 SP No.3, 22-19:2x4 SP No.2
WEBS 2x4 SP No.3 *Except*
23-25,25-7,23-7,23-8,17-8,17-9:2x4 SP No.2

BRACING
TOP CHORD Structural wood sheathing directly applied or 3-10-14 oc purlins, except end verticals, and 2-0-0 oc purlins (4-3-11 max.); 7-9.
BOT CHORD Rigid ceiling directly applied or 6-0-0 oc bracing. Except:
1 Row at midpt 6-25
6-0-0 oc bracing: 19-22
WEBS 1 Row at midpt 7-23, 8-22, 8-19, 10-15

REACTIONS (size) 13= Mechanical, 14=0-5-8, 29=0-5-8
Max Horiz 29=-186 (LC 12)
Max Uplift 13=-90 (LC 15), 29=-49 (LC 14)
Max Grav 13=242 (LC 43), 14=3029 (LC 45), 29=2400 (LC 45)

FORCES (lb) - Maximum Compression/Maximum Tension
TOP CHORD 1-2=0/27, 2-3=-2241/91, 3-4=-3398/90, 4-6=-3349/103, 6-7=-3339/192, 7-8=-2591/104, 8-9=-2287/112, 9-10=-2678/77, 10-12=-2064/132, 12-13=-115/322, 2-29=-2340/106
BOT CHORD 28-29=-19/53, 27-28=0/38, 3-27=-1111/40, 26-27=-152/2033, 25-26=-42/2991, 24-25=-327/0, 6-25=-492/160, 23-24=-77/87, 21-23=0/2637, 17-21=0/2637, 15-17=0/1775, 14-15=-236/25, 13-14=-236/92, 20-22=-71/0, 19-20=-71/0

WEBS 4-25=-219/166, 23-25=0/2651, 7-25=-319/1076, 7-23=-80/705, 22-23=-282/205, 8-22=-213/281, 20-21=-384/0, 8-19=-633/161, 17-19=-731/112, 9-17=0/840, 10-17=0/991, 10-15=-1274/0, 12-15=0/2287, 12-14=-2602/103, 4-26=-256/48, 3-26=0/1071, 27-29=-126/198, 2-27=-66/2315

- NOTES**
- Unbalanced roof live loads have been considered for this design.
 - Wind: ASCE 7-16; Vult=130mph (3-second gust) Vasd=103mph; TCDL=6.0psf; BCDL=6.0psf; h=25ft; Cat. II; Exp B; Enclosed; MWFRS (envelope) exterior zone and C-C Exterior(2E) -0-10-8 to 4-5-5, Interior (1) 4-5-5 to 10-1-12, Exterior(2R) 10-1-12 to 38-11-4, Interior (1) 38-11-4 to 47-10-3, Exterior(2E) 47-10-3 to 53-2-0 zone; cantilever left and right exposed; end vertical left and right exposed; C-C for members and forces & MWFRS for reactions shown; Lumber DOL=1.60 plate grip DOL=1.60
 - TCLL: ASCE 7-16; Pr=20.0 psf (roof LL: Lum DOL=1.15 Plate DOL=1.15); Pf=20.0 psf (Lum DOL=1.15 Plate DOL=1.15); Is=1.0; Rough Cat B; Fully Exp.; Ce=0.9; Cs=1.00; Ct=1.10
 - Unbalanced snow loads have been considered for this design.
 - This truss has been designed for greater of min roof live load of 12.0 psf or 1.00 times flat roof load of 20.0 psf on overhangs non-concurrent with other live loads.
 - 200.0lb AC unit load placed on the bottom chord, 24-6-8 from left end, supported at two points, 5-0-0 apart.
 - Provide adequate drainage to prevent water ponding.
 - This truss has been designed for a 10.0 psf bottom chord live load nonconcurrent with any other live loads.

- * This truss has been designed for a live load of 20.0psf on the bottom chord in all areas where a rectangle 3-06-00 tall by 2-00-00 wide will fit between the bottom chord and any other members, with BCDL = 10.0psf.
- Refer to girder(s) for truss to truss connections.
- Provide mechanical connection (by others) of truss to bearing plate capable of withstanding 90 lb uplift at joint 13.
- One H2.5A Simpson Strong-Tie connectors recommended to connect truss to bearing walls due to UPLIFT at jt(s) 29. This connection is for uplift only and does not consider lateral forces.
- This truss is designed in accordance with the 2018 International Residential Code sections R502.11.1 and R802.10.2 and referenced standard ANSI/TPI 1.
- Graphical purlin representation does not depict the size or the orientation of the purlin along the top and/or bottom chord.

LOAD CASE(S) Standard

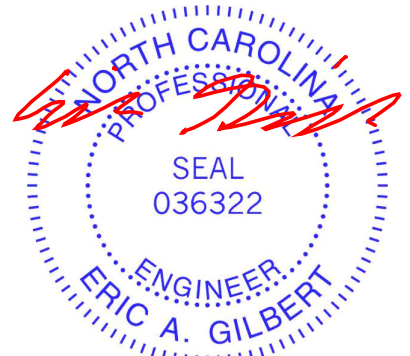

April 14, 2023

WARNING - Verify design parameters and READ NOTES ON THIS AND INCLUDED MITEK REFERENCE PAGE MII-7473 rev. 5/19/2020 BEFORE USE.

Design valid for use only with MiTek® connectors. This design is based only upon parameters shown, and is for an individual building component, not a truss system. Before use, the building designer must verify the applicability of design parameters and properly incorporate this design into the overall building design. Bracing indicated is to prevent buckling of individual truss web and/or chord members only. Additional temporary and permanent bracing is always required for stability and to prevent collapse with possible personal injury and property damage. For general guidance regarding the fabrication, storage, delivery, erection and bracing of trusses and truss systems, see ANSITPI Quality Criteria, DSB-89 and BCSI Building Component Safety Information available from Truss Plate Institute, 2670 Crain Highway, Suite 203 Waldorf, MD 20601



818 Soundside Road
Edenton, NC 27932

Job 23040053-01	Truss A3	Truss Type Attic	Qty 6	Ply 1	David Weekly-11 Serenity-Roof-B326 A Job Reference (optional)	I57767108
--------------------	-------------	---------------------	----------	----------	--	-----------

Carter Components (Sanford), Sanford, NC - 27332,

Run: 8.53 S Mar 9 2023 Print: 8.530 S Mar 9 2023 MiTek Industries, Inc. Thu Apr 13 16:16:42
ID:h5TFO2tlZyfvWspKto8_zRQij-RfC?PsB70Hq3NSgPqnL8w3uTlXbGKwCDoi7J4zJC7f

Page: 1

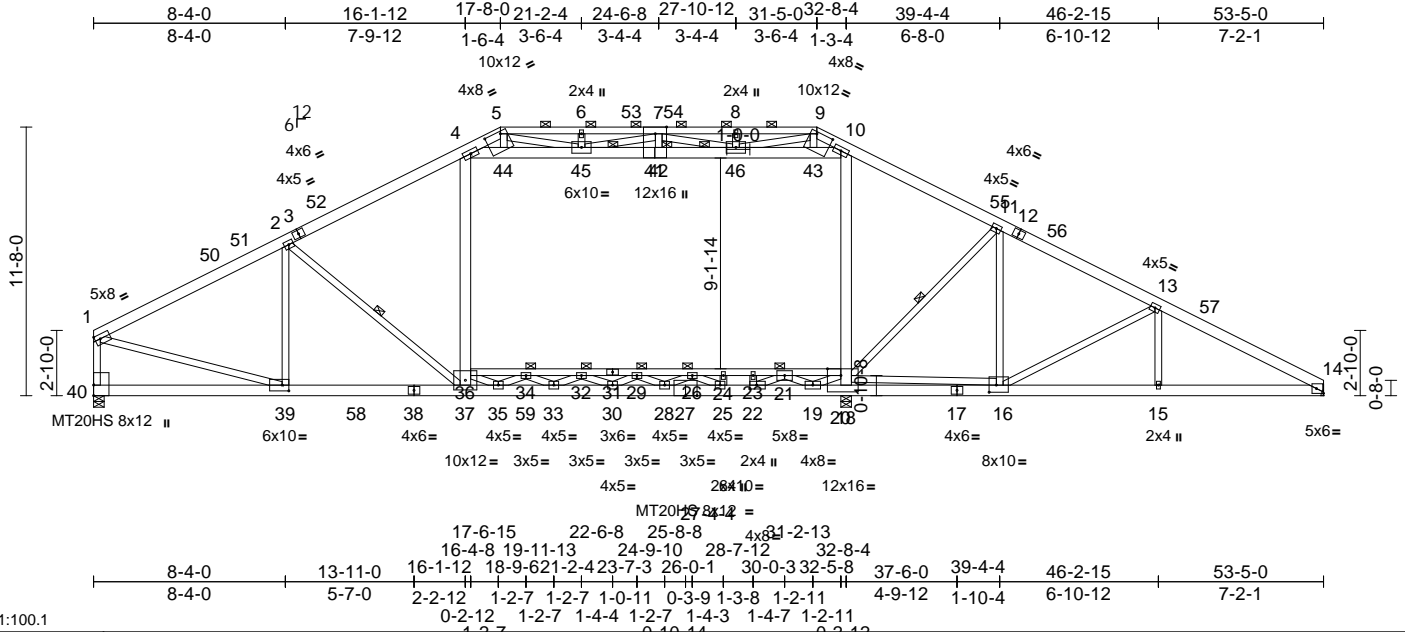

Scale = 1:100.1

Plate Offsets (X, Y): [1:Edge,0-2-4], [5:0-8-8,0-1-4], [9:0-8-12,0-1-0], [14:Edge,0-2-8], [16:0-3-12,0-3-12], [18:0-7-0,Edge], [22:0-3-8,0-2-0], [39:0-3-8,0-3-0], [41:Edge,0-5-14]

Loading	(psf)	Spacing	2-0-0	CSI	DEFL	in (loc)	l/defl	L/d	PLATES	GRIP		
TCLL (roof)	20.0	Plate Grip DOL	1.15	TC	0.85	Vert(LL)	-0.39	29-32	>993	240	MT20	244/190
Snow (Pf)	20.0	Lumber DOL	1.15	BC	0.90	Vert(CT)	-0.66	32-34	>594	180	MT20HS	187/143
TCDL	10.0	Rep Stress Incr	YES	WB	0.86	Horz(CT)	0.12	14	n/a	n/a		
BCLL	0.0*	Code	IRC2018/TPI2014	Matrix-MSH		Attic	-0.27	20-36	>734	360		
BCDL	10.0											
											Weight: 493 lb	FT = 20%

LUMBER
TOP CHORD 2x6 SP No.2 *Except* 5-9:2x4 SP No.2
BOT CHORD 2x6 SP No.2 *Except* 36-31:2x4 SP No.2, 27-17,38-27:2x6 SP 2400F 2.0E, 31-20:2x4 SP No.1
WEBS 2x4 SP No.3 *Except* 4-37,10-18,41-10,41-4:2x6 SP No.2, 39-1,20-19,19-21,21-22,36-35,35-34,34-33,3 3-32,29-28,28-26,26-25:2x4 SP No.2, 20-16:2x4 SP No.1

BRACING
TOP CHORD Structural wood sheathing directly applied or 3-0-14 oc purlins, except end verticals, and 2-0-0 oc purlins (3-3-8 max.): 5-9.
BOT CHORD Rigid ceiling directly applied or 10-0-0 oc bracing, Except: 6-0-0 oc bracing: 18-19 5-7-7 oc bracing: 16-18.
WEBS 1 Row at midpt 2-37, 11-20
JOINTS 1 Brace at Jt(s): 42, 21, 34, 32, 29, 26, 45, 46

REACTIONS (size) 14= Mechanical, 18=0-5-8, 40=0-5-8
Max Horiz 40=-191 (LC 12)
Max Uplift 18=-74 (LC 15), 40=-11 (LC 14)
Max Grav 14=2313 (LC 45), 18=1753 (LC 37), 40=2953 (LC 35)

FORCES (lb) - Maximum Compression/Maximum Tension
TOP CHORD 1-2=-3833/6, 2-4=-3928/0, 4-5=-1725/147, 5-6=-2698/396, 6-7=-2698/396, 7-8=-2583/406, 8-9=-2583/406, 9-10=-1627/160, 10-11=-3724/41, 11-13=-3839/36, 13-14=-4399/37, 1-40=-2818/53

NOTES
1) Unbalanced roof live loads have been considered for this design.

2) Wind: ASCE 7-16; Vult=130mph (3-second gust) Vasd=103mph; TCDL=6.0psf; BCDL=6.0psf; h=25ft; Cat. II; Exp B; Enclosed; MWFRS (envelope) exterior zone and C-C Exterior(2E) 0-1-12 to 5-5-14, Interior (1) 5-5-14 to 10-1-6, Exterior(2R) 10-1-6 to 38-11-10, Interior (1) 38-11-10 to 48-0-14, Exterior(2E) 48-0-14 to 53-5-0 zone; cantilever left and right exposed ; end vertical left and right exposed; C-C for members and forces & MWFRS for reactions shown; Lumber DOL=1.60 plate grip DOL=1.60

3) TCLL: ASCE 7-16; Pr=20.0 psf (roof LL: Lum DOL=1.15 Plate DOL=1.15); Pf=20.0 psf (Lum DOL=1.15 Plate DOL=1.15); Is=1.0; Rough Cat B; Fully Exp.; Ce=0.9; Cs=1.00; Ct=1.10

4) Unbalanced snow loads have been considered for this design.

5) Provide adequate drainage to prevent water ponding.

6) All plates are MT20 plates unless otherwise indicated.

7) All plates are 4x5 MT20 unless otherwise indicated.

8) This truss has been designed for a 10.0 psf bottom chord live load nonconcurrent with any other live loads.



April 14, 2023

Continued on page 2

WARNING - Verify design parameters and READ NOTES ON THIS AND INCLUDED MITEK REFERENCE PAGE MII-7473 rev. 5/19/2020 BEFORE USE.

Design valid for use only with MiTek® connectors. This design is based only upon parameters shown, and is for an individual building component, not a truss system. Before use, the building designer must verify the applicability of design parameters and properly incorporate this design into the overall building design. Bracing indicated is to prevent buckling of individual truss web and/or chord members only. Additional temporary and permanent bracing is always required for stability and to prevent collapse with possible personal injury and property damage. For general guidance regarding the fabrication, storage, delivery, erection and bracing of trusses and truss systems, see ANSITPI Quality Criteria, DSB-89 and BCSI Building Component Safety Information available from Truss Plate Institute, 2670 Crain Highway, Suite 203 Waldorf, MD 20601



818 Soundside Road
Edenton, NC 27932

Job	Truss	Truss Type	Qty	Ply	David Weekly-11 Serenity-Roof-B326 A
23040053-01	A3	Attic	6	1	I57767108
					Job Reference (optional)

Carter Components (Sanford), Sanford, NC - 27332,

Run: 8.53 S Mar 9 2023 Print: 8.530 S Mar 9 2023 MiTek Industries, Inc. Thu Apr 13 16:16:42
 ID:h5TFO2tlZyfWTVvSpKto8_zRQij-RfC?PsB70Hq3NSgPqnL8w3uITxbGKWrcDoi7J4zJC?f

Page: 2

- 9) * This truss has been designed for a live load of 20.0psf on the bottom chord in all areas where a rectangle 3-06-00 tall by 2-00-00 wide will fit between the bottom chord and any other members, with BCDL = 10.0psf.
- 10) Ceiling dead load (5.0 psf) on member(s). 4-44, 44-45, 42-45, 42-46, 43-46, 10-43; Wall dead load (5.0psf) on member(s).4-36, 10-20
- 11) Bottom chord live load (40.0 psf) and additional bottom chord dead load (5.0 psf) applied only to room. 34-36, 32-34, 29-32, 26-29, 24-26, 23-24, 21-23, 20-21
- 12) Refer to girder(s) for truss to truss connections.
- 13) One H2.5A Simpson Strong-Tie connectors recommended to connect truss to bearing walls due to UPLIFT at jt(s) 40 and 18. This connection is for uplift only and does not consider lateral forces.
- 14) This truss is designed in accordance with the 2018 International Residential Code sections R502.11.1 and R802.10.2 and referenced standard ANSI/TPI 1.
- 15) Graphical purlin representation does not depict the size or the orientation of the purlin along the top and/or bottom chord.
- 16) Attic room checked for L/360 deflection.

LOAD CASE(S) Standard

WARNING - Verify design parameters and READ NOTES ON THIS AND INCLUDED MITEK REFERENCE PAGE MII-7473 rev. 5/19/2020 BEFORE USE.

Design valid for use only with MiTek® connectors. This design is based only upon parameters shown, and is for an individual building component, not a truss system. Before use, the building designer must verify the applicability of design parameters and properly incorporate this design into the overall building design. Bracing indicated is to prevent buckling of individual truss web and/or chord members only. Additional temporary and permanent bracing is always required for stability and to prevent collapse with possible personal injury and property damage. For general guidance regarding the fabrication, storage, delivery, erection and bracing of trusses and truss systems, see **ANSI/TPI1 Quality Criteria, DSB-89 and BCSI Building Component Safety Information** available from Truss Plate Institute, 2670 Crain Highway, Suite 203 Waldorf, MD 20601



818 Soundside Road
 Edenton, NC 27932

Job 23040053-01	Truss A3GE	Truss Type Attic Supported Gable	Qty 1	Ply 1	David Weekly-11 Serenity-Roof-B326 A 157767109 Job Reference (optional)
--------------------	---------------	-------------------------------------	----------	----------	---

Carter Components (Sanford), Sanford, NC - 27332,

Run: 8.53 S Mar 9 2023 Print: 8.530 S Mar 9 2023 MiTek Industries, Inc. Thu Apr 13 16:16:49

Page: 2

ID:8kdnANvfrXy7X5iJovJ26tzRBB2-RfC?PsB70Hq3NSgPqnL8w3uITXbGKwCDoi7J4zJC?f

- WEBS
- 5-60=-288/32, 54-55=-957/41,
10-54=-979/140, 36-38=-730/36,
16-38=-868/151, 20-34=-521/113,
25-31=-205/11, 10-68=-47/585,
68-69=-51/616, 67-69=-458/2719,
67-70=-458/2719, 66-70=-53/572,
16-66=-48/538, 1-85=-41/181,
84-85=-39/176, 83-84=-40/178,
60-83=-40/180, 15-66=-49/162,
13-67=-8/120, 34-77=-17/142,
77-78=-14/140, 78-79=-14/134,
25-79=-14/139, 5-82=-17/143,
81-82=-17/142, 80-81=-16/141,
55-80=-17/144, 11-68=-26/185, 40-41=-62/0,
42-43=-74/0, 37-38=-250/52, 37-39=-129/0,
39-40=-145/0, 53-54=-96/0, 52-53=-148/0,
51-52=-169/0, 50-51=-131/0, 48-50=-123/0,
47-48=-139/0, 46-47=-128/0, 44-46=-118/0,
43-44=-97/0, 38-71=-92/80, 71-73=-91/79,
73-75=-92/80, 34-75=-103/85, 38-72=0/76,
72-74=0/80, 74-76=0/102, 20-76=0/87,
12-69=-302/89, 11-69=-275/1451,
13-69=-765/149, 14-70=-299/89,
15-70=-274/1462, 13-70=-783/166,
1-64=-155/63, 17-72=-24/35, 71-72=-14/28,
18-74=-67/28, 73-74=-33/16, 19-76=-25/7,
75-76=-31/18, 22-77=-15/16, 23-78=-144/60,
33-78=-179/40, 24-79=-105/55,
32-79=-101/61, 26-30=-147/38,
27-29=-154/85, 9-80=-82/172,
56-80=-82/167, 8-81=-177/70,
58-81=-175/70, 7-82=-193/59,
59-82=-194/61, 4-83=-23/18, 3-84=-194/92,
61-84=-223/100, 2-85=-127/73,
62-85=-108/78, 1-63=-41/16
- 13) Provide mechanical connection (by others) of truss to bearing plate capable of withstanding 72 lb uplift at joint 64, 17 lb uplift at joint 60, 49 lb uplift at joint 55, 134 lb uplift at joint 34, 25 lb uplift at joint 37, 24 lb uplift at joint 33, 34 lb uplift at joint 32, 8 lb uplift at joint 30, 75 lb uplift at joint 29, 130 lb uplift at joint 56, 45 lb uplift at joint 58, 41 lb uplift at joint 59, 60 lb uplift at joint 61 and 60 lb uplift at joint 62.
- 14) This truss is designed in accordance with the 2018 International Residential Code sections R502.11.1 and R802.10.2 and referenced standard ANSI/TPI 1.
- 15) Graphical purlin representation does not depict the size or the orientation of the purlin along the top and/or bottom chord.
- 16) Attic room checked for L/360 deflection.

LOAD CASE(S) Standard

NOTES

- Unbalanced roof live loads have been considered for this design.
- Wind: ASCE 7-16; Vult=130mph (3-second gust)
Vasd=103mph; TC DL=6.0psf; BC DL=6.0psf; h=25ft;
Cat. II; Exp B; Enclosed; MWFRS (envelope) exterior zone and C-C Exterior(2E) 0-3-1 to 5-7-2, Interior (1) 5-7-2 to 10-1-6, Exterior(2R) 10-1-6 to 38-11-10, Interior (1) 38-11-10 to 48-0-14, Exterior(2E) 48-0-14 to 53-5-0 zone; cantilever left and right exposed ; end vertical left and right exposed; C-C for members and forces & MWFRS for reactions shown; Lumber DOL=1.60 plate grip DOL=1.60
- Truss designed for wind loads in the plane of the truss only. For studs exposed to wind (normal to the face), see Standard Industry Gable End Details as applicable, or consult qualified building designer as per ANSI/TPI 1.
- TCLL: ASCE 7-16; Pr=20.0 psf (roof LL: Lum DOL=1.15 Plate DOL=1.15); Pf=20.0 psf (Lum DOL=1.15 Plate DOL=1.15); Is=1.0; Rough Cat B; Fully Exp.; Ce=0.9; Cs=1.00; Ct=1.10
- Unbalanced snow loads have been considered for this design.
- Provide adequate drainage to prevent water ponding.
- All plates are 2x4 MT20 unless otherwise indicated.
- Gable requires continuous bottom chord bearing.
- Gable studs spaced at 2-0-0 oc.
- This truss has been designed for a 10.0 psf bottom chord live load nonconcurrent with any other live loads.
- * This truss has been designed for a live load of 20.0psf on the bottom chord in all areas where a rectangle 3-06-00 tall by 2-00-00 wide will fit between the bottom chord and any other members, with BCDL = 10.0psf.
- Ceiling dead load (5.0 psf) on member(s). 10-68, 68-69, 67-69, 67-70, 66-70, 16-66; Wall dead load (5.0psf) on member(s).10-54, 16-38, 33-78, 26-30

WARNING - Verify design parameters and READ NOTES ON THIS AND INCLUDED MITEK REFERENCE PAGE MII-7473 rev. 5/19/2020 BEFORE USE.

Design valid for use only with MiTek® connectors. This design is based only upon parameters shown, and is for an individual building component, not a truss system. Before use, the building designer must verify the applicability of design parameters and properly incorporate this design into the overall building design. Bracing indicated is to prevent buckling of individual truss web and/or chord members only. Additional temporary and permanent bracing is always required for stability and to prevent collapse with possible personal injury and property damage. For general guidance regarding the fabrication, storage, delivery, erection and bracing of trusses and truss systems, see **ANSI/TPI1 Quality Criteria, DSB-89 and BCSI Building Component Safety Information** available from Truss Plate Institute, 2670 Crain Highway, Suite 203 Waldorf, MD 20601

ENGINEERING BY
TRENCO
A MiTek Affiliate

818 Soundside Road
Edenton, NC 27932

Job 23040053-01	Truss A4	Truss Type Attic	Qty 1	Ply 1	David Weekly-11 Serenity-Roof-B326 A Job Reference (optional)	I57767110
--------------------	-------------	---------------------	----------	----------	--	-----------

Carter Components (Sanford), Sanford, NC - 27332,

Run: 8.53 S Mar 9 2023 Print: 8.530 S Mar 9 2023 MiTek Industries, Inc. Thu Apr 13 16:16:54

Page: 1

ID:1d51NYb_SnpjqifH0e1reGzRBHO-RfC?PsB70Hq3NSgPqnL8w3ulTXhGKWRcDoi7J4zC?f

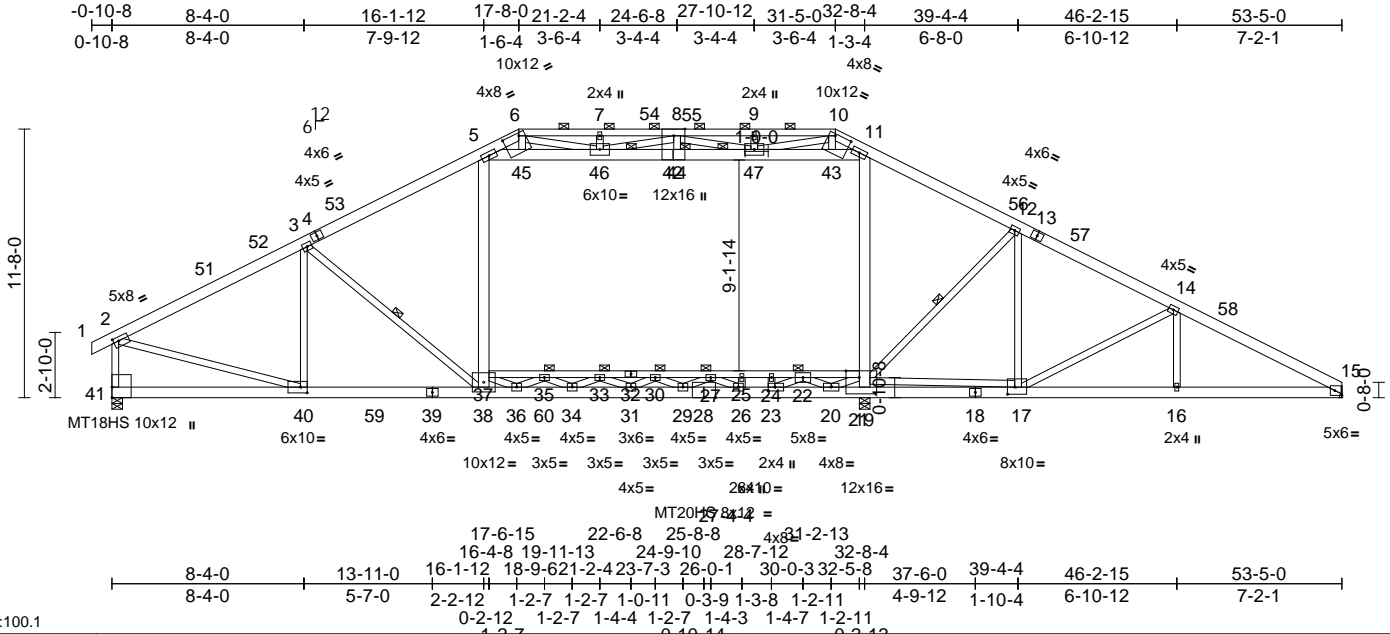

Scale = 1:100.1

Plate Offsets (X, Y): [2:0-2-12,0-2-0], [6:0-8-12,0-1-8], [10:0-8-12,0-1-0], [15:Edge,0-2-8], [17:0-3-12,0-3-12], [19:0-7-0,Edge], [23:0-3-8,0-2-0], [40:0-3-8,0-3-0], [42:Edge,0-5-14]

Loading	(psf)	Spacing	2-0-0	CSI	DEFL	in (loc)	l/defl	L/d	PLATES	GRIP		
TCLL (roof)	20.0	Plate Grip DOL	1.15	TC	0.96	Vert(LL)	-0.39	30-33	>993	240	MT20	244/190
Snow (Pf)	20.0	Lumber DOL	1.15	BC	0.90	Vert(CT)	-0.66	33-35	>594	180	MT18HS	244/190
TCDL	10.0	Rep Stress Incr	YES	WB	0.86	Horz(CT)	0.12	15	n/a	n/a	MT20HS	187/143
BCLL	0.0*	Code	IRC2018/TPI2014	Matrix-MSH		Attic	-0.27	21-37	>734	360		
BCDL	10.0											
											Weight: 495 lb	FT = 20%

LUMBER	TOP CHORD	BOT CHORD	WEBS	BRACING	TOP CHORD	BOT CHORD	WEBS	JOINTS	REACTIONS	FORCES	TOP CHORD
2x6 SP No.2 *Except* 6-10:2x4 SP No.2	2x6 SP No.2 *Except* 37-32:2x4 SP No.2, 18-28,28-39:2x6 SP 2400F 2.0E, 32-21:2x4 SP No.1	2x4 SP No.3 *Except* 5-38,11-19,42-11,42-5:2x6 SP No.2, 40-2,21-20,20-22,22-23,37-36,36-35,35-34,34-33,30-29,29-27,27-26:2x4 SP No.2, 21-17:2x4 SP No.1	Structural wood sheathing directly applied or 3-0-7 oc purlins, except end verticals, and 2-0-0 oc purlins (3-3-9 max.): 6-10.	Rigid ceiling directly applied or 10-0-0 oc bracing, Except: 6-0-0 oc bracing: 19-20 5-7-7 oc bracing: 17-19.	1 Row at midpt 3-38, 12-21 1 Brace at Jt(s): 44, 22, 35, 33, 30, 27, 46, 47	15= Mechanical, 19=0-5-8, 41=0-5-8	Max Horiz 41=-188 (LC 12)	Max Uplift 19=-74 (LC 15), 41=-30 (LC 14)	Max Grav 15=2313 (LC 46), 19=1760 (LC 38), 41=3005 (LC 36)	(lb) - Maximum Compression/Maximum Tension	1-2=0/27, 2-3=-3830/11, 3-5=-3926/0, 5-6=-1722/147, 6-7=-2696/396, 7-8=-2696/396, 8-9=-2582/406, 9-10=-2582/406, 10-11=-1626/160, 11-12=-3722/44, 12-14=-3837/37, 14-15=-4398/37, 2-41=-2869/73
40-41=-112/225, 38-40=-16/3355, 36-38=0/3329, 34-36=0/5013, 31-34=0/6223, 29-31=0/6493, 26-29=0/5351, 23-26=0/3841, 20-23=0/1720, 19-20=-1996/0, 17-19=-1696/0, 16-17=0/3858, 15-16=-13/3858, 35-37=-774/0, 33-35=-2689/0, 30-33=-3453/0, 27-30=-3220/0, 25-27=-909/787, 24-25=-909/787, 22-24=-909/787, 21-22=0/3708	3-40=-645/67, 37-38=0/434, 5-37=0/1171, 19-21=-941/244, 11-21=-34/1171, 12-17=-237/110, 14-16=0/258, 5-45=-2373/0, 45-46=-2305/0, 44-46=-1885/1246, 44-47=-1885/1246, 43-47=-2392/22, 11-43=-2543/25, 2-40=0/3399, 10-43=-15/678, 8-44=0/227, 14-17=-594/198, 3-38=-159/366, 6-45=-16/403, 23-24=-395/0, 25-26=0/135, 20-21=0/1706, 20-22=-2722/0, 22-23=0/2450, 36-37=0/1075, 35-36=-1447/0, 34-35=0/845, 33-34=-721/0, 31-33=-102/188, 30-31=-136/127, 29-30=-430/0, 27-29=0/960, 26-27=-1750/0, 17-21=0/4646, 12-21=-590/316, 7-46=-279/91, 6-46=-312/1228, 8-46=-951/130, 9-47=-282/93, 10-47=-317/1336, 8-47=-1006/137	3-40=-645/67, 37-38=0/434, 5-37=0/1171, 19-21=-941/244, 11-21=-34/1171, 12-17=-237/110, 14-16=0/258, 5-45=-2373/0, 45-46=-2305/0, 44-46=-1885/1246, 44-47=-1885/1246, 43-47=-2392/22, 11-43=-2543/25, 2-40=0/3399, 10-43=-15/678, 8-44=0/227, 14-17=-594/198, 3-38=-159/366, 6-45=-16/403, 23-24=-395/0, 25-26=0/135, 20-21=0/1706, 20-22=-2722/0, 22-23=0/2450, 36-37=0/1075, 35-36=-1447/0, 34-35=0/845, 33-34=-721/0, 31-33=-102/188, 30-31=-136/127, 29-30=-430/0, 27-29=0/960, 26-27=-1750/0, 17-21=0/4646, 12-21=-590/316, 7-46=-279/91, 6-46=-312/1228, 8-46=-951/130, 9-47=-282/93, 10-47=-317/1336, 8-47=-1006/137	1) Row at midpt 3-38, 12-21 1 Brace at Jt(s): 44, 22, 35, 33, 30, 27, 46, 47	15= Mechanical, 19=0-5-8, 41=0-5-8	Max Horiz 41=-188 (LC 12)	Max Uplift 19=-74 (LC 15), 41=-30 (LC 14)	Max Grav 15=2313 (LC 46), 19=1760 (LC 38), 41=3005 (LC 36)	(lb) - Maximum Compression/Maximum Tension	1-2=0/27, 2-3=-3830/11, 3-5=-3926/0, 5-6=-1722/147, 6-7=-2696/396, 7-8=-2696/396, 8-9=-2582/406, 9-10=-2582/406, 10-11=-1626/160, 11-12=-3722/44, 12-14=-3837/37, 14-15=-4398/37, 2-41=-2869/73		
<p>NOTES</p> <p>1) Unbalanced roof live loads have been considered for this design.</p>											

- Wind: ASCE 7-16; Vult=130mph (3-second gust) Vasd=103mph; TCDL=6.0psf; BCDL=6.0psf; h=25ft; Cat. II; Exp B; Enclosed; MWFRS (envelope) exterior zone and C-C Exterior(2E) -0-10-8 to 4-5-10, Interior (1) 4-5-10 to 10-1-6, Exterior(2R) 10-1-6 to 38-11-10, Interior (1) 38-11-10 to 48-0-14, Exterior(2E) 48-0-14 to 53-5-0 zone; cantilever left and right exposed ; end vertical left and right exposed; C-C for members and forces & MWFRS for reactions shown; Lumber DOL=1.60 plate grip DOL=1.60
- TCLL: ASCE 7-16; Pr=20.0 psf (roof LL: Lum DOL=1.15 Plate DOL=1.15); Pf=20.0 psf (Lum DOL=1.15 Plate DOL=1.15); Is=1.0; Rough Cat B; Fully Exp.; Ce=0.9; Cs=1.00; Ct=1.10
- Unbalanced snow loads have been considered for this design.
- This truss has been designed for greater of min roof live load of 12.0 psf or 1.00 times flat roof load of 20.0 psf on overhangs non-concurrent with other live loads.
- Provide adequate drainage to prevent water ponding.
- All plates are MT20 unless otherwise indicated.
- All plates are 4x5 MT20 unless otherwise indicated.



April 14, 2023

Continued on page 2

WARNING - Verify design parameters and READ NOTES ON THIS AND INCLUDED MITEK REFERENCE PAGE MII-7473 rev. 5/19/2020 BEFORE USE.

Design valid for use only with MiTek® connectors. This design is based only upon parameters shown, and is for an individual building component, not a truss system. Before use, the building designer must verify the applicability of design parameters and properly incorporate this design into the overall building design. Bracing indicated is to prevent buckling of individual truss web and/or chord members only. Additional temporary and permanent bracing is always required for stability and to prevent collapse with possible personal injury and property damage. For general guidance regarding the fabrication, storage, delivery, erection and bracing of trusses and truss systems, see **ANSI/TPI Quality Criteria, DSB-89 and BCSI Building Component Safety Information** available from Truss Plate Institute, 2670 Crain Highway, Suite 203 Waldorf, MD 20601



818 Soundside Road
Edenton, NC 27932

Job 23040053-01	Truss A4	Truss Type Attic	Qty 1	Ply 1	David Weekly-11 Serenity-Roof-B326 A I57767110 Job Reference (optional)
--------------------	-------------	---------------------	----------	----------	---

Carter Components (Sanford), Sanford, NC - 27332,

Run: 8.53 S Mar 9 2023 Print: 8.530 S Mar 9 2023 MiTek Industries, Inc. Thu Apr 13 16:16:54
ID:1d5INYb_SnpjifH0e1reGzRBHO-RfC?PsB70Hq3NSgPqnL8w3ulTXbGKWrcDoi7J4zJC?f

Page: 2

- 9) This truss has been designed for a 10.0 psf bottom chord live load nonconcurrent with any other live loads.
- 10) * This truss has been designed for a live load of 20.0psf on the bottom chord in all areas where a rectangle 3-06-00 tall by 2-00-00 wide will fit between the bottom chord and any other members, with BCDL = 10.0psf.
- 11) Ceiling dead load (5.0 psf) on member(s). 5-45, 45-46, 44-46, 44-47, 43-47, 11-43; Wall dead load (5.0psf) on member(s).5-37, 11-21
- 12) Bottom chord live load (40.0 psf) and additional bottom chord dead load (5.0 psf) applied only to room. 35-37, 33-35, 30-33, 27-30, 25-27, 24-25, 22-24, 21-22
- 13) Refer to girder(s) for truss to truss connections.
- 14) One H2.5A Simpson Strong-Tie connectors recommended to connect truss to bearing walls due to UPLIFT at jt(s) 41 and 19. This connection is for uplift only and does not consider lateral forces.
- 15) This truss is designed in accordance with the 2018 International Residential Code sections R502.11.1 and R802.10.2 and referenced standard ANSI/TPI 1.
- 16) Graphical purlin representation does not depict the size or the orientation of the purlin along the top and/or bottom chord.
- 17) Attic room checked for L/360 deflection.

LOAD CASE(S) Standard

WARNING - Verify design parameters and READ NOTES ON THIS AND INCLUDED MITEK REFERENCE PAGE MII-7473 rev. 5/19/2020 BEFORE USE.

Design valid for use only with MiTek® connectors. This design is based only upon parameters shown, and is for an individual building component, not a truss system. Before use, the building designer must verify the applicability of design parameters and properly incorporate this design into the overall building design. Bracing indicated is to prevent buckling of individual truss web and/or chord members only. Additional temporary and permanent bracing is always required for stability and to prevent collapse with possible personal injury and property damage. For general guidance regarding the fabrication, storage, delivery, erection and bracing of trusses and truss systems, see **ANSI/TPI1 Quality Criteria, DSB-89 and BCSI Building Component Safety Information** available from Truss Plate Institute, 2670 Crain Highway, Suite 203 Waldorf, MD 20601



818 Soundside Road
Edenton, NC 27932

Job 23040053-01	Truss A4GR	Truss Type Attic Girder	Qty 1	Ply 4	David Weekly-11 Serenity-Roof-B326 A Job Reference (optional)	I57767111
--------------------	---------------	----------------------------	----------	----------	--	-----------

Carter Components (Sanford), Sanford, NC - 27332,

Run: 8.53 S Mar 9 2023 Print: 8.530 S Mar 9 2023 MiTek Industries, Inc. Thu Apr 13 16:16:58
ID:PgZvt1?lwruiNEY_xH4fkzRrAp7-RfC?PsB70Hq3NSgPqnL8w3u1TXbGKwRcDoi7J4zJC?f

Page: 1

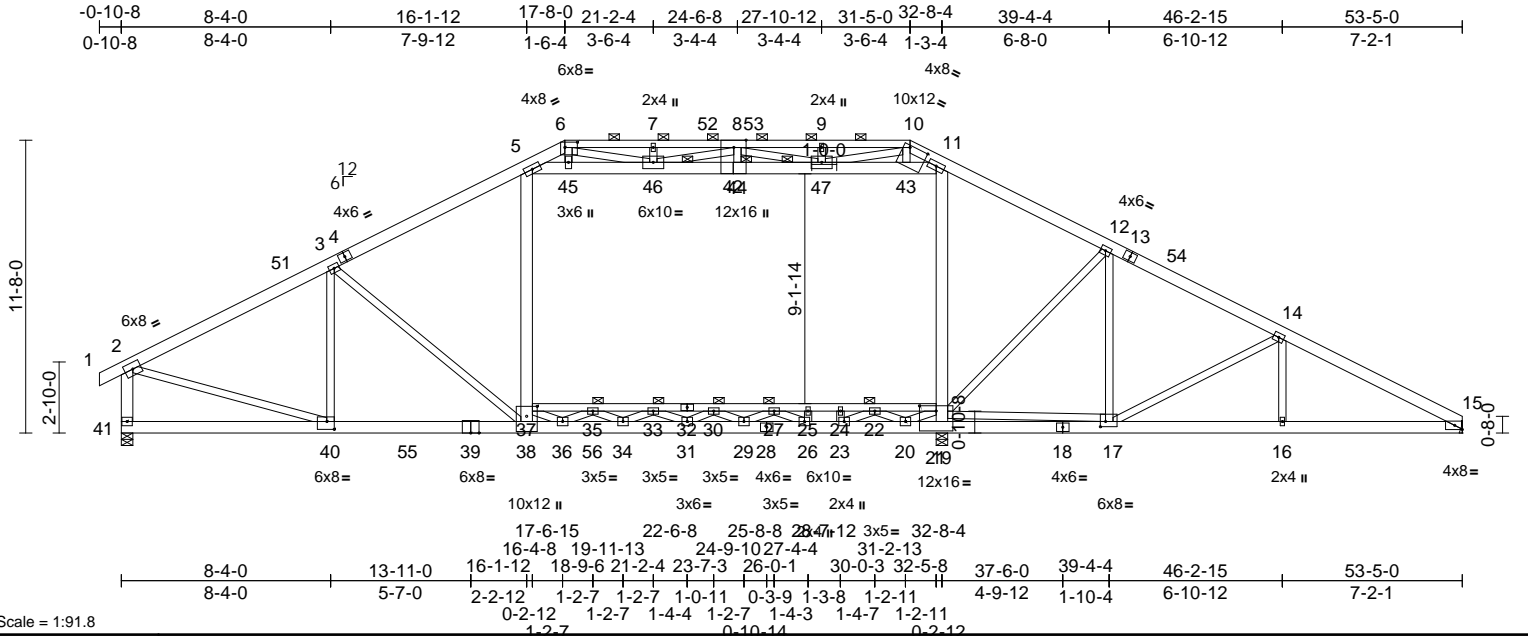

Scale = 1:91.8
Plate Offsets (X, Y): [6:0-6-0,0-2-8], [10:0-9-0,0-1-0], [17:0-2-8,0-2-8], [19:0-8-0,0-2-8], [37:0-4-12,0-5-0], [40:0-3-8,0-3-12], [42:Edge,0-5-14]

Loading	(psf)	Spacing	2-0-0	CSI	DEFL	in	(loc)	l/defl	L/d	PLATES	GRIP	
TCLL (roof)	20.0	Plate Grip DOL	1.15	TC	0.77	Vert(LL)	-0.40	38-40	>967	240	MT20	244/190
Snow (Pf)	20.0	Lumber DOL	1.15	BC	0.98	Vert(CT)	-0.61	38-40	>642	180		
TCDL	10.0	Rep Stress Incr	NO	WB	0.92	Horz(CT)	0.10	15	n/a	n/a		
BCLL	0.0*	Code	IRC2018/TPI2014	Matrix-MSH		Attic	-0.20	21-37	>987	360		
BCDL	10.0											
											Weight: 1988 lb	FT = 20%

LUMBER		BOT CHORD		
TOP CHORD	2x6 SP No.2 *Except* 6-10:2x4 SP No.2	40-41=-138/410, 38-40=-1014/14912,		
BOT CHORD	2x6 SP 2400F 2.0E *Except* 37-32:2x4 SP No.2, 39-41:2x6 SP No.2, 32-21:2x4 SP No.1	36-38=-1200/18263, 34-36=-697/18903,		
WEBS	2x4 SP No.3 *Except* 41-2,5-38,11-19,42-11,42-5:2x6 SP No.2, 40-2:2x4 SP No.1, 21-17:2x4 SP No.2	31-34=-198/17557, 29-31=0/15575,		
BRACING		26-29=0/11995, 23-26=0/9184,		
TOP CHORD	Structural wood sheathing directly applied or 6-0-0 oc purlins, except end verticals, and 2-0-0 oc purlins (6-0-0 max.): 6-10.	20-23=-87/5680, 19-20=-487/835,		
BOT CHORD	Rigid ceiling directly applied or 10-0-0 oc bracing, except: 6-0-0 oc bracing: 19-20.	17-19=-689/3267, 16-17=-961/15893,		
JOINTS	1 Brace at Jt(s): 44, 22, 35, 33, 30, 27, 46, 47	15-16=-961/15893, 35-37=-2134/36,		
REACTIONS	(size) 15= Mechanical, 19=0-5-8, 41=0-5-8	33-35=-1708/0, 30-33=-1005/1211,		
	Max Horiz 41=-189 (LC 10)	27-30=-1202/3084, 25-27=-1128/8019,		
	Max Uplift 15=-522 (LC 12), 19=-4548 (LC 45), 41=-832 (LC 12)	24-25=-1128/8019, 22-24=-1128/8019,		
	Max Grav 15=8746 (LC 46), 19=831 (LC 12), 41=12198 (LC 46)	21-22=-699/14744		
FORCES	(lb) - Maximum Compression/Maximum Tension	WEBS		
TOP CHORD	1-2=0/30, 2-3=-16650/1131, 3-5=-19441/1334, 5-6=-4814/433, 6-7=-4415/587, 7-8=-4415/587, 8-9=-4173/586, 9-10=-4173/586, 10-11=-4884/456, 11-12=-18854/1350, 12-14=-17866/1248, 14-15=-17912/1142, 2-41=-12061/877	3-40=-3880/337, 37-38=-573/7505,		
		5-37=-480/8325, 19-21=-734/6286,		
		11-21=-591/7755, 12-17=-1532/140,		
		14-16=-135/118, 5-45=-13023/908,		
		45-46=-12751/886, 44-46=-12467/672,		
		44-47=-12467/672, 43-47=-13270/947,		
		11-43=-13967/997, 2-40=-916/15167,		
		10-43=-213/3037, 8-44=-40/779,		
		14-17=-262/299, 3-38=-227/3401,		
		6-45=-117/1557, 23-24=-689/0, 25-26=0/298,		
		20-21=0/2483, 20-22=-3926/0,		
		22-23=0/4054, 36-37=0/1335,		
		35-36=-441/640, 34-35=-904/338,		
		33-34=-258/706, 31-33=-1258/201,		
		30-31=-149/1121, 29-30=-1744/94,		
		27-29=-13/2541, 26-27=-3260/0,		
		17-21=-305/12831, 12-21=-138/1518,		
		7-46=-201/142, 6-46=-1311/526,		
		8-46=-1954/233, 9-47=-220/108,		
		10-47=-981/766, 8-47=-2156/252		
NOTES				



April 14, 2023

Continued on page 2

WARNING - Verify design parameters and READ NOTES ON THIS AND INCLUDED MITEK REFERENCE PAGE MII-7473 rev. 5/19/2020 BEFORE USE.

Design valid for use only with MiTek® connectors. This design is based only upon parameters shown, and is for an individual building component, not a truss system. Before use, the building designer must verify the applicability of design parameters and properly incorporate this design into the overall building design. Bracing indicated is to prevent buckling of individual truss web and/or chord members only. Additional temporary and permanent bracing is always required for stability and to prevent collapse with possible personal injury and property damage. For general guidance regarding the fabrication, storage, delivery, erection and bracing of trusses and truss systems, see **ANSI/TPI Quality Criteria, DSB-89 and BCSI Building Component Safety Information** available from Truss Plate Institute, 2670 Crain Highway, Suite 203 Waldorf, MD 20601

ENGINEERING BY
TRENCO
A MiTek Affiliate

818 Soundside Road
Edenton, NC 27932

Job 23040053-01	Truss A4GR	Truss Type Attic Girder	Qty 1	Ply 4	David Weekly-11 Serenity-Roof-B326 A I57767111 Job Reference (optional)
--------------------	---------------	----------------------------	----------	----------	---

Carter Components (Sanford), Sanford, NC - 27332,

Run: 8.53 S Mar 9 2023 Print: 8.530 S Mar 9 2023 MiTek Industries, Inc. Thu Apr 13 16:16:58
ID:pGeZvt1?lwruINEY_xH4fkzRAp7-RfC?PsB70Hq3NSgPqnL8w3uITXbGKwRCDoi7J4zJC?

Page: 2

- 4) Wind: ASCE 7-16; Vult=130mph (3-second gust)
Vasd=103mph; TCDL=6.0psf; BCDL=6.0psf; h=25ft;
Cat. II; Exp B; Enclosed; MWFRS (envelope) exterior
zone; cantilever left and right exposed ; end vertical left
and right exposed; Lumber DOL=1.60 plate grip
DOL=1.60
- 5) TCELL: ASCE 7-16; Pr=20.0 psf (roof LL: Lum DOL=1.15
Plate DOL=1.15); Pf=20.0 psf (Lum DOL=1.15 Plate
DOL=1.15); Is=1.0; Rough Cat B; Fully Exp.; Ce=0.9;
Cs=1.00; Ct=1.10
- 6) Unbalanced snow loads have been considered for this
design.
- 7) This truss has been designed for greater of min roof live
load of 12.0 psf or 1.00 times flat roof load of 20.0 psf on
overhangs non-concurrent with other live loads.
- 8) Provide adequate drainage to prevent water ponding.
- 9) All plates are 4x5 MT20 unless otherwise indicated.
- 10) This truss has been designed for a 10.0 psf bottom
chord live load nonconcurrent with any other live loads.
- 11) * This truss has been designed for a live load of 20.0psf
on the bottom chord in all areas where a rectangle
3-06-00 tall by 2-00-00 wide will fit between the bottom
chord and any other members, with BCDL = 10.0psf.
- 12) Ceiling dead load (5.0 psf) on member(s). 5-45, 45-46,
44-46, 44-47, 43-47, 11-43; Wall dead load (5.0psf) on
member(s).5-37, 11-21
- 13) Bottom chord live load (40.0 psf) and additional bottom
chord dead load (5.0 psf) applied only to room. 35-37,
33-35, 30-33, 27-30, 25-27, 24-25, 22-24, 21-22
- 14) Refer to girder(s) for truss to truss connections.
- 15) Provide mechanical connection (by others) of truss to
bearing plate capable of withstanding 522 lb uplift at
joint 15 and 4548 lb uplift at joint 19.
- 16) LGT4-SDS3 Simpson Strong-Tie connectors
recommended to connect truss to bearing walls due to
UPLIFT at jt(s) 41. This connection is for uplift only and
does not consider lateral forces.
- 17) This truss is designed in accordance with the 2018
International Residential Code sections R502.11.1 and
R802.10.2 and referenced standard ANSI/TPI 1.
- 18) Graphical purlin representation does not depict the size
or the orientation of the purlin along the top and/or
bottom chord.
- 19) This truss has large uplift reaction(s) from gravity load
case(s). Proper connection is required to secure truss
against upward movement at the bearings. Building
designer must provide for uplift reactions indicated.
- 20) LGT4 Hurricane ties must have four studs in line below
the truss.
- 21) Hanger(s) or other connection device(s) shall be
provided sufficient to support concentrated load(s)
10250 lb down and 872 lb up at 16-1-12 on bottom
chord. The design/selection of such connection device
(s) is the responsibility of others.
- 22) Attic room checked for L/360 deflection.

LOAD CASE(S) Standard

- 1) Dead + Snow (balanced): Lumber Increase=1.15, Plate
Increase=1.15
Uniform Loads (lb/ft)
Vert: 1-2=-60, 2-6=-60, 6-10=-60, 10-15=-60,
41-48=-20, 21-37=-30, 5-45=-10, 45-46=-10,
42-46=-10, 42-44=-10, 44-47=-10, 43-47=-10,
11-43=-10
Drag: 5-37=-10, 11-21=-10
Concentrated Loads (lb)
Vert: 38=-5498 (F)

WARNING - Verify design parameters and READ NOTES ON THIS AND INCLUDED MITEK REFERENCE PAGE MII-7473 rev. 5/19/2020 BEFORE USE.

Design valid for use only with MiTek® connectors. This design is based only upon parameters shown, and is for an individual building component, not a truss system. Before use, the building designer must verify the applicability of design parameters and properly incorporate this design into the overall building design. Bracing indicated is to prevent buckling of individual truss web and/or chord members only. Additional temporary and permanent bracing is always required for stability and to prevent collapse with possible personal injury and property damage. For general guidance regarding the fabrication, storage, delivery, erection and bracing of trusses and truss systems, see **ANSI/TPI1 Quality Criteria, DSB-89 and BCSI Building Component**

Safety Information available from Truss Plate Institute, 2670 Crain Highway, Suite 203 Waldorf, MD 20601



818 Soundside Road
Edenton, NC 27932

Job 23040053-01	Truss B1GE	Truss Type Common Structural Gable	Qty 1	Ply 1	David Weekly-11 Serenity-Roof-B326 A Job Reference (optional)	I57767112
--------------------	---------------	---------------------------------------	----------	----------	--	-----------

Carter Components (Sanford), Sanford, NC - 27332,

Run: 8.53 S Mar 9 2023 Print: 8.530 S Mar 9 2023 MiTek Industries, Inc. Thu Apr 13 16:17:03
ID:bYvcELrthF7aR0JRUAUJmAzRQ4-RfC?PsB70Hq3NSgPqnL8w3ulTXbGKWRcDoi7J4zC?f

Page: 1

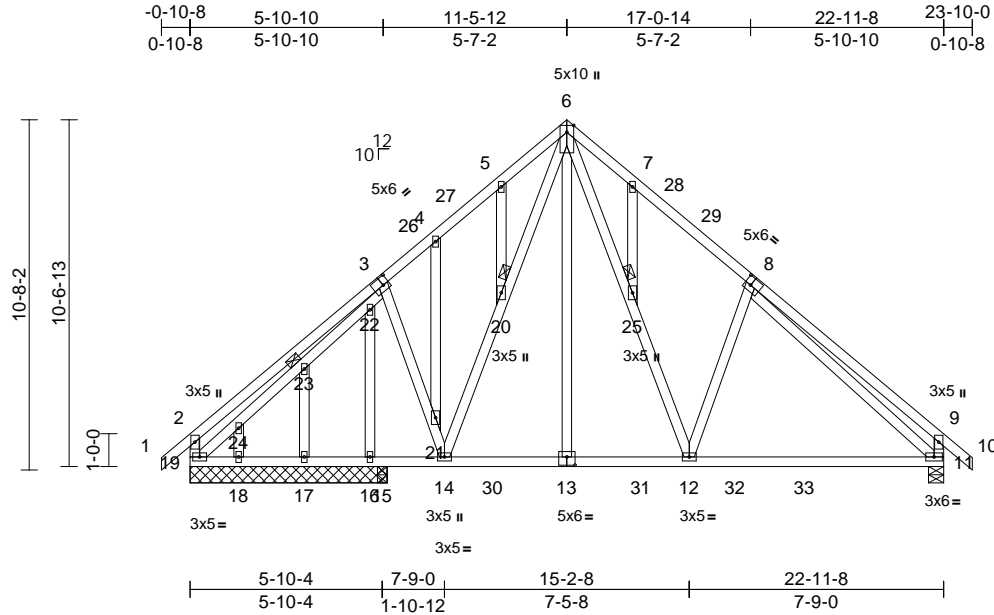

Scale = 1:70.2

Plate Offsets (X, Y): [3:0-2-4,0-3-0], [8:0-2-4,0-3-0], [13:0-3-0,0-3-0]

Loading	(psf)	Spacing	2-0-0	CSI	DEFL	in	(loc)	l/defl	L/d	PLATES	GRIP	
TCLL (roof)	20.0	Plate Grip DOL	1.15	TC	0.45	Vert(LL)	-0.12	11-12	>999	240	MT20	244/190
Snow (Pf)	20.0	Lumber DOL	1.15	BC	0.59	Vert(CT)	-0.21	11-12	>967	180		
TCDL	10.0	Rep Stress Incr	YES	WB	0.68	Horz(CT)	0.02	11	n/a	n/a		
BCLL	0.0*	Code	IRC2018/TPI2014	Matrix-MSH								
BCDL	10.0											
											Weight: 201 lb	FT = 20%

LUMBER
TOP CHORD 2x4 SP No.2
BOT CHORD 2x4 SP No.2
WEBS 2x4 SP No.3 *Except* 12-6,14-6:2x4 SP No.2
OTHERS 2x4 SP No.3

BRACING
TOP CHORD Structural wood sheathing directly applied or 5-9-13 oc purlins, except end verticals.
BOT CHORD Rigid ceiling directly applied or 10-0-0 oc bracing.
JOINTS 1 Brace at Jt(s): 20, 23, 25

REACTIONS (size)
11=0-5-8, 15=0-3-8, 16=6-0-0,
17=6-0-0, 18=6-0-0, 19=6-0-0
Max Horiz 19=265 (LC 13)
Max Uplift 11=-96 (LC 15), 15=-54 (LC 14),
17=-2 (LC 12), 18=-21 (LC 14),
19=-106 (LC 14)
Max Grav 11=953 (LC 6), 15=219 (LC 24),
16=436 (LC 25), 17=58 (LC 7),
18=103 (LC 24), 19=523 (LC 21)

FORCES (lb) - Maximum Compression/Maximum Tension
TOP CHORD 1-2=0/39, 2-4=-597/238, 4-5=-620/264,
5-6=-545/297, 6-7=-756/262, 7-9=-908/231,
9-10=0/39, 2-19=-350/226, 9-11=-507/218
BOT CHORD 18-19=-125/476, 17-18=-125/476,
16-17=-125/476, 15-16=-125/476,
14-15=-125/476, 12-14=-10/506,
11-12=-3/686

WEBS
6-25=-180/560, 12-25=-157/565,
8-12=-267/246, 14-20=-207/92,
6-20=-244/122, 3-21=-2/294, 4-21=-44/277,
19-24=-370/21, 23-24=-372/17,
22-23=-352/33, 3-22=-778/0, 8-11=-588/0,
6-13=0/163, 5-20=-63/38, 4-21=-182/56,
16-22=-537/14, 17-23=-26/61, 18-24=-12/8,
7-25=-60/34

NOTES

- Unbalanced roof live loads have been considered for this design.
- Wind: ASCE 7-16; Vult=130mph (3-second gust) Vasd=103mph; TCDL=6.0psf; BCDL=6.0psf; h=25ft; Cat. II; Exp B; Enclosed; MWFRS (envelope) exterior zone and C-C Exterior(2E) 0-10-8 to 2-1-8, Interior (1) 2-1-8 to 8-3-6, Exterior(2R) 8-3-6 to 14-3-6, Interior (1) 14-3-6 to 20-10-0, Exterior(2E) 20-10-0 to 23-10-0 zone; cantilever left and right exposed; end vertical left and right exposed; C-C for members and forces & MWFRS for reactions shown; Lumber DOL=1.60 plate grip DOL=1.60
- Truss designed for wind loads in the plane of the truss only. For studs exposed to wind (normal to the face), see Standard Industry Gable End Details as applicable, or consult qualified building designer as per ANSI/TPI 1.
- TCLL: ASCE 7-16; Pr=20.0 psf (roof LL: Lum DOL=1.15 Plate DOL=1.15); Is=1.0; Rough Cat B; Fully Exp.; Ce=0.9; Cs=1.00; Ct=1.10
- Unbalanced snow loads have been considered for this design.
- This truss has been designed for greater of min roof live load of 12.0 psf or 1.00 times flat roof load of 20.0 psf on overhangs non-concurrent with other live loads.
- All plates are 2x4 MT20 unless otherwise indicated.
- Truss to be fully sheathed from one face or securely braced against lateral movement (i.e. diagonal web).

- Gable studs spaced at 2-0-0 oc.
- This truss has been designed for a 10.0 psf bottom chord live load nonconcurrent with any other live loads.
- * This truss has been designed for a live load of 20.0psf on the bottom chord in all areas where a rectangle 3-06-00 tall by 2-00-00 wide will fit between the bottom chord and any other members, with BCDL = 10.0psf.
- N/A
- N/A
- This truss is designed in accordance with the 2018 International Residential Code sections R502.11.1 and R802.10.2 and referenced standard ANSI/TPI 1.

LOAD CASE(S) Standard



April 14, 2023

WARNING - Verify design parameters and READ NOTES ON THIS AND INCLUDED MITEK REFERENCE PAGE MII-7473 rev. 5/19/2020 BEFORE USE.

Design valid for use only with MiTek® connectors. This design is based only upon parameters shown, and is for an individual building component, not a truss system. Before use, the building designer must verify the applicability of design parameters and properly incorporate this design into the overall building design. Bracing indicated is to prevent buckling of individual truss web and/or chord members only. Additional temporary and permanent bracing is always required for stability and to prevent collapse with possible personal injury and property damage. For general guidance regarding the fabrication, storage, delivery, erection and bracing of trusses and truss systems, see **ANSI/TPI Quality Criteria, DSB-89 and BCSI Building Component Safety Information** available from Truss Plate Institute, 2670 Crain Highway, Suite 203 Waldorf, MD 20601



818 Soundside Road
Edenton, NC 27932

Job 23040053-01	Truss B1GR	Truss Type Common Girder	Qty 1	Ply 2	David Weekly-11 Serenity-Roof-B326 A Job Reference (optional)	I57767113
--------------------	---------------	-----------------------------	----------	----------	--	-----------

Carter Components (Sanford), Sanford, NC - 27332,

Run: 8.53 S Mar 9 2023 Print: 8.530 S Mar 9 2023 MiTek Industries, Inc. Thu Apr 13 16:17:04
ID:iFFKd9_s5HOVK9vBFwqTAGzRAMn-RfC?PsB70Hq3NSgPqnL8w3uITxBGKwRCDoi7J4zJC?f

Page: 1

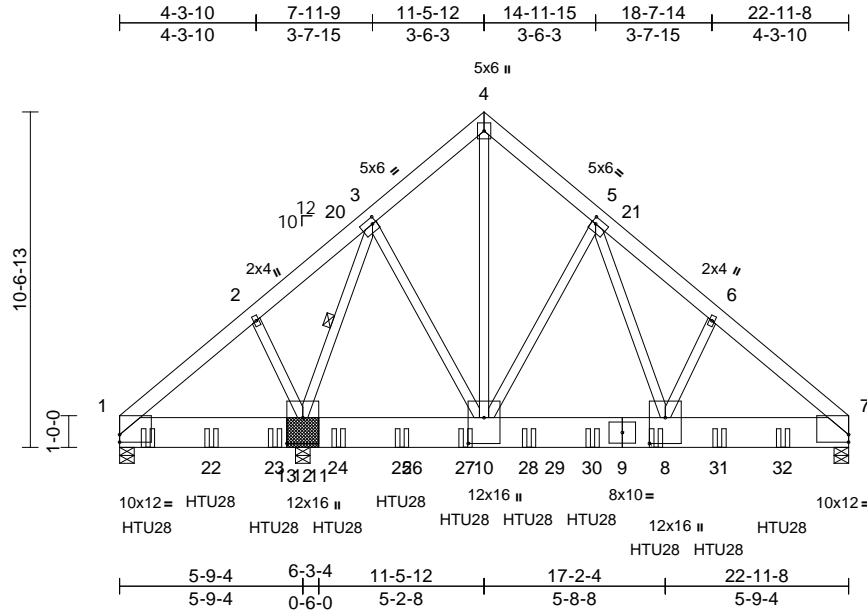

Scale = 1:72.6

Plate Offsets (X, Y): [1:Edge,0-2-13], [3:0-1-8,0-2-4], [5:0-1-8,0-2-4], [7:Edge,0-2-13], [8:0-9-12,0-6-0], [10:0-9-12,0-6-0], [12:0-9-12,0-6-0]

Loading	(psf)	Spacing	2-0-0	CSI	DEFL	in	(loc)	l/defl	L/d	PLATES	GRIP	
TCLL (roof)	20.0	Plate Grip DOL	1.15	TC	0.34	Vert(LL)	-0.10	8-10	>999	240	MT20	244/190
Snow (Pf)	20.0	Lumber DOL	1.15	BC	0.34	Vert(CT)	-0.18	8-10	>999	180		
TCDL	10.0	Rep Stress Incr	NO	WB	0.83	Horz(CT)	0.01	7	n/a	n/a		
BCLL	0.0*	Code	IRC2018/TPI2014	Matrix-MSH								
BCDL	10.0											
											Weight: 509 lb	FT = 20%

LUMBER
TOP CHORD 2x6 SP No.2
BOT CHORD 2x12 SP 2400F 2.0E
WEBS 2x4 SP No.2

BRACING
TOP CHORD Structural wood sheathing directly applied or 4-6-15 oc purlins.
BOT CHORD Rigid ceiling directly applied or 10-0-0 oc bracing, Except: 6-0-0 oc bracing: 1-12.
WEBS 1 Row at midpt 3-12

REACTIONS (size) 1=0-5-8, 7=0-5-8, 12=(0-5-8 + bearing block), (req. 0-5-10)
Max Horiz 1=225 (LC 11)
Max Uplift 1=-332 (LC 8), 7=-841 (LC 13), 12=-1035 (LC 12)
Max Grav 1=4173 (LC 22), 7=9663 (LC 6), 12=13659 (LC 5)

FORCES (lb) - Maximum Compression/Maximum Tension
TOP CHORD 1-2=-135/166, 2-3=-82/180, 3-4=-5604/515, 4-5=-5658/495, 5-6=-10570/982, 6-7=-10664/911
BOT CHORD 1-12=-179/217, 10-12=-194/2301, 8-10=-400/6077, 7-8=-632/8129
WEBS 4-10=-565/6784, 2-12=-367/175, 3-12=-7979/621, 3-10=-326/4530, 5-10=-3833/566, 5-8=-758/6672, 6-8=-134/177

NOTES
1) 2-ply truss to be connected together with 10d (0.131"x3") nails as follows:
Top chords connected as follows: 2x6 - 2 rows staggered at 0-9-0 oc.
Bottom chords connected as follows: 2x12 - 4 rows staggered at 0-4-0 oc.
Web connected as follows: 2x4 - 1 row at 0-9-0 oc.

- All loads are considered equally applied to all plies, except if noted as front (F) or back (B) face in the LOAD CASE(S) section. Ply to ply connections have been provided to distribute only loads noted as (F) or (B), unless otherwise indicated.
- 2x12 SP 2400F 2.0E bearing block 12" long at jt. 12 attached to each face with 6 rows of 10d (0.131"x3") nails spaced 3" o.c. 24 Total fasteners per block. Bearing is assumed to be SP 2400F 2.0E.
- Unbalanced roof live loads have been considered for this design.
- Wind: ASCE 7-16; Vult=130mph (3-second gust) Vasd=103mph; TCDL=6.0psf; BCDL=6.0psf; h=25ft; Cat. II; Exp B; Enclosed; MWFRS (envelope) exterior zone; cantilever left and right exposed; end vertical left and right exposed; Lumber DOL=1.60 plate grip DOL=1.60
- TCLL: ASCE 7-16; Pr=20.0 psf (roof LL: Lum DOL=1.15 Plate DOL=1.15); Pf=20.0 psf (Lum DOL=1.15 Plate DOL=1.15); Is=1.0; Rough Cat B; Fully Exp.; Ce=0.9; Cs=1.00; Ct=1.10
- Unbalanced snow loads have been considered for this design.
- This truss has been designed for a 10.0 psf bottom chord live load nonconcurrent with any other live loads.
- * This truss has been designed for a live load of 20.0psf on the bottom chord in all areas where a rectangle 3-06-00 tall by 2-00-00 wide will fit between the bottom chord and any other members, with BCDL = 10.0psf.
- LGT2 Simpson Strong-Tie connectors recommended to connect truss to bearing walls due to UPLIFT at jt(s) 1, 7, and 12. This connection is for uplift only and does not consider lateral forces.
- This truss is designed in accordance with the 2018 International Residential Code sections R502.11.1 and R802.10.2 and referenced standard ANSI/TPI 1.

- Use Simpson Strong-Tie HTU28 (26-10d Girder, 14-10dx1 1/2 Truss, Single Ply Girder) or equivalent spaced at 2-0-0 oc max. starting at 0-10-12 from the left end to 20-10-12 to connect truss(es) to front face of bottom chord.
 - Fill all nail holes where hanger is in contact with lumber.
 - LGT2 Hurricane ties must have two studs in line below the truss.
 - Hanger(s) or other connection device(s) shall be provided sufficient to support concentrated load(s) 3059 lb down and 254 lb up at 0-0-0 on bottom chord. The design/selection of such connection device(s) is the responsibility of others.
- LOAD CASE(S)** Standard
1) Dead + Snow (balanced): Lumber Increase=1.15, Plate Increase=1.15
Uniform Loads (lb/ft)
Vert: 1-4=-60, 4-7=-60, 14-17=-20
Concentrated Loads (lb)



April 14, 2023

Continued on page 2

WARNING - Verify design parameters and READ NOTES ON THIS AND INCLUDED MITEK REFERENCE PAGE MII-7473 rev. 5/19/2020 BEFORE USE.
Design valid for use only with MiTek® connectors. This design is based only upon parameters shown, and is for an individual building component, not a truss system. Before use, the building designer must verify the applicability of design parameters and properly incorporate this design into the overall building design. Bracing indicated is to prevent buckling of individual truss web and/or chord members only. Additional temporary and permanent bracing is always required for stability and to prevent collapse with possible personal injury and property damage. For general guidance regarding the fabrication, storage, delivery, erection and bracing of trusses and truss systems, see **ANSI/TPI1 Quality Criteria, DSB-89 and BCSI Building Component Safety Information** available from Truss Plate Institute, 2670 Crain Highway, Suite 203 Waldorf, MD 20601



Job 23040053-01	Truss B1GR	Truss Type Common Girder	Qty 1	Ply 2	David Weekly-11 Serenity-Roof-B326 A I57767113 Job Reference (optional)
--------------------	---------------	-----------------------------	----------	-----------------	---

Carter Components (Sanford), Sanford, NC - 27332,

Run: 8.53 S Mar 9 2023 Print: 8.530 S Mar 9 2023 MiTek Industries, Inc. Thu Apr 13 16:17:04
ID:iFFKd9_s5HOVK9vBFwqTAGzRAMn-RfC?PsB70Hq3NSgPqnL8w3uITxbGKWrCDoi7J4zJC?f

Page: 2

Vert: 8=-2152 (F), 14=-1953, 16=-1821 (F), 22=-222 (F), 23=-222 (F), 24=-2365 (F), 25=-2365 (F), 27=-2365 (F), 28=-2152 (F), 30=-2152 (F), 31=-2152 (F), 32=-2152 (F)

WARNING - Verify design parameters and READ NOTES ON THIS AND INCLUDED MITEK REFERENCE PAGE MII-7473 rev. 5/19/2020 BEFORE USE.

Design valid for use only with MiTek® connectors. This design is based only upon parameters shown, and is for an individual building component, not a truss system. Before use, the building designer must verify the applicability of design parameters and properly incorporate this design into the overall building design. Bracing indicated is to prevent buckling of individual truss web and/or chord members only. Additional temporary and permanent bracing is always required for stability and to prevent collapse with possible personal injury and property damage. For general guidance regarding the fabrication, storage, delivery, erection and bracing of trusses and truss systems, see **ANSI/TPI1 Quality Criteria, DSB-89 and BCSI Building Component Safety Information** available from Truss Plate Institute, 2670 Crain Highway, Suite 203 Waldorf, MD 20601



818 Soundside Road
Edenton, NC 27932

Job 23040053-01	Truss C1	Truss Type Monopitch	Qty 4	Ply 1	David Weekly-11 Serenity-Roof-B326 A Job Reference (optional)	I57767114
--------------------	-------------	-------------------------	----------	----------	--	-----------

Carter Components (Sanford), Sanford, NC - 27332,

Run: 8.53 S Mar 9 2023 Print: 8.530 S Mar 9 2023 MiTek Industries, Inc. Thu Apr 13 16:17:05
ID:Qb5lZxyP1s84s5fJHsVqazRR57-RfC?PsB70Hq3NSgPqnL8w3ulTXbGKWrCDoi7J4zJC?f

Page: 1

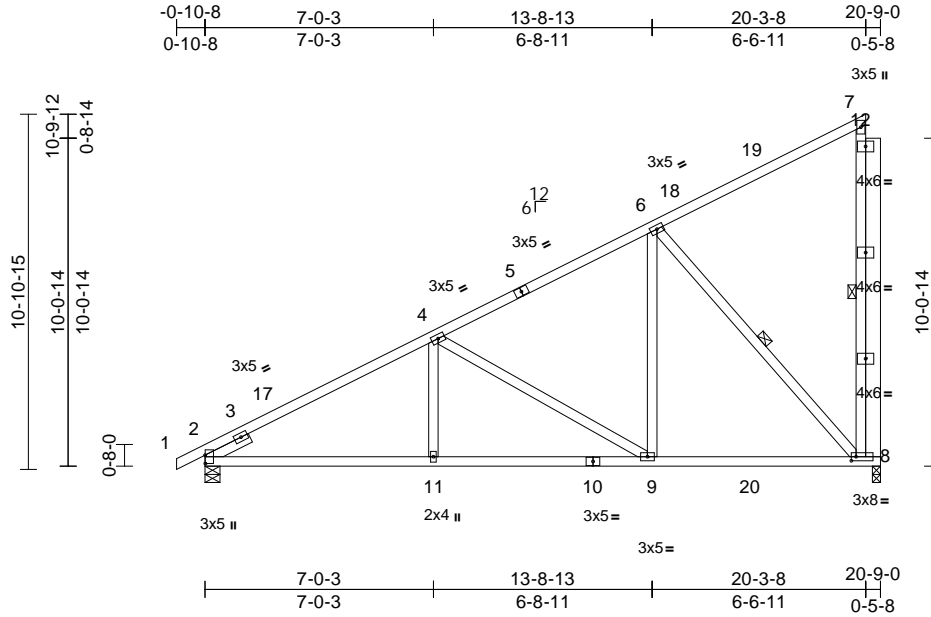

Scale = 1:70.8
Plate Offsets (X, Y): [2:0-3-1,0-0-1], [8:0-1-12,0-1-8]

Loading	(psf)	Spacing	2-0-0	CSI	DEFL	in	(loc)	l/defl	L/d	PLATES	GRIP	
TCLL (roof)	20.0	Plate Grip DOL	1.15	TC	0.78	Vert(LL)	-0.07	8-9	>999	240	MT20	244/190
Snow (Pf)	20.0	Lumber DOL	1.15	BC	0.60	Vert(CT)	-0.12	8-9	>999	180		
TCDL	10.0	Rep Stress Incr	YES	WB	0.68	Horz(CT)	0.03	8	n/a	n/a		
BCLL	0.0*	Code	IRC2018/TPI2014	Matrix-MSH								
BCDL	10.0											
											Weight: 147 lb	FT = 20%

LUMBER
TOP CHORD 2x4 SP No.2
BOT CHORD 2x4 SP No.2
WEBS 2x4 SP No.3 *Except* 7-8:2x4 SP No.2
OTHERS 2x6 SP No.2
SLIDER Left 2x4 SP No.3 -- 1-6-0

BRACING
TOP CHORD Structural wood sheathing directly applied or 4-9-8 oc purlins, except end verticals.
BOT CHORD Rigid ceiling directly applied or 10-0-0 oc bracing.
WEBS 1 Row at midpt 7-8, 6-8

REACTIONS (size) 2=0-5-8, 8=0-3-0
Max Horiz 2=394 (LC 13)
Max Uplift 2=-96 (LC 14), 8=-178 (LC 14)
Max Grav 2=940 (LC 5), 8=1018 (LC 5)

FORCES (lb) - Maximum Compression/Maximum Tension
TOP CHORD 1-2=0/23, 2-4=-1347/171, 4-6=-817/157, 6-7=-219/141, 7-8=-263/80
BOT CHORD 2-11=-297/1150, 9-11=-212/1150, 8-9=-110/651
WEBS 4-11=0/265, 4-9=-593/177, 6-9=-3/582, 6-8=-942/223

- TCLL: ASCE 7-16; Pr=20.0 psf (roof LL: Lum DOL=1.15 Plate DOL=1.15); Pf=20.0 psf (Lum DOL=1.15 Plate DOL=1.15); Is=1.0; Rough Cat B; Fully Exp.; Ce=0.9; Cs=1.00; Ct=1.10
 - Unbalanced snow loads have been considered for this design.
 - This truss has been designed for greater of min roof live load of 12.0 psf or 1.00 times flat roof load of 20.0 psf on overhangs non-concurrent with other live loads.
 - All plates are 3x5 MT20 unless otherwise indicated.
 - This truss has been designed for a 10.0 psf bottom chord live load nonconcurrent with any other live loads.
 - * This truss has been designed for a live load of 20.0psf on the bottom chord in all areas where a rectangle 3-06-00 tall by 2-00-00 wide will fit between the bottom chord and any other members, with BCDL = 10.0psf.
 - One H2.5A Simpson Strong-Tie connectors recommended to connect truss to bearing walls due to UPLIFT at jt(s) 8 and 2. This connection is for uplift only and does not consider lateral forces.
 - This truss is designed in accordance with the 2018 International Residential Code sections R502.11.1 and R802.10.2 and referenced standard ANSI/TPI 1.
- LOAD CASE(S)** Standard

NOTES
1) Wind: ASCE 7-16; Vult=130mph (3-second gust)
Vasd=103mph; TCDL=6.0psf; BCDL=6.0psf; h=25ft;
Cat. II; Exp B; Enclosed; MWFRS (envelope) exterior zone and C-C Exterior(2E) -0-10-8 to 2-1-8, Interior (1) 2-1-8 to 17-1-12, Exterior(2E) 17-1-12 to 20-1-12 zone; cantilever left and right exposed ; end vertical left and right exposed;C-C for members and forces & MWFRS for reactions shown; Lumber DOL=1.60 plate grip DOL=1.60



April 14, 2023

Job 23040053-01	Truss C2	Truss Type Monopitch	Qty 1	Ply 1	David Weekly-11 Serenity-Roof-B326 A Job Reference (optional)	I57767115
--------------------	-------------	-------------------------	----------	----------	--	-----------

Carter Components (Sanford), Sanford, NC - 27332,

Run: 8.53 S Mar 9 2023 Print: 8.530 S Mar 9 2023 MiTek Industries, Inc. Thu Apr 13 16:17:06
ID:I6FRV_evE0OIUkDZDZDzHacuzRR_f-RfC?PsB70Hq3NSgPqnL8w3ulTXbGKwRCDoi7J4zJC?f

Page: 1

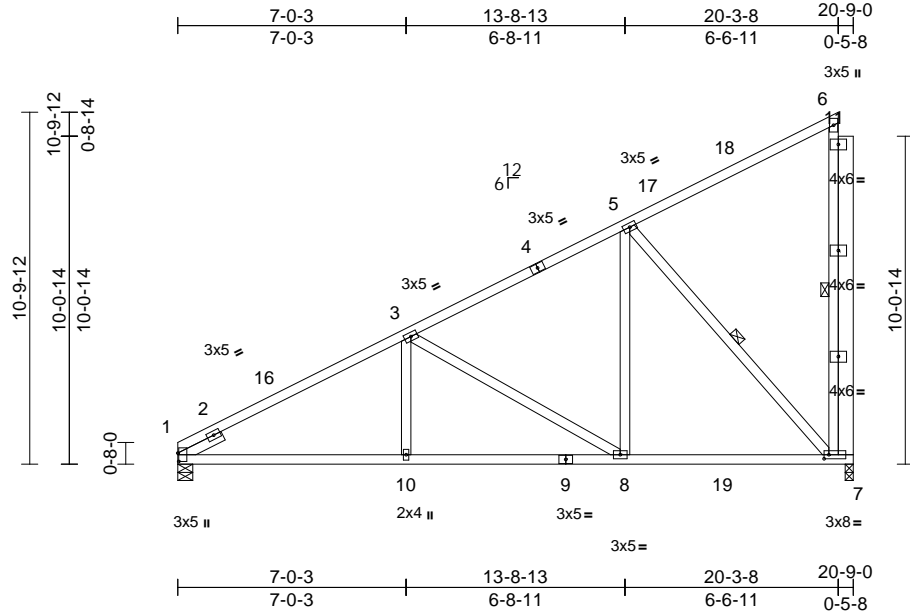

Scale = 1:70.8
Plate Offsets (X, Y): [1:0-3-1,0-0-5], [7:0-1-12,0-1-8]

Loading	(psf)	Spacing	2-0-0	CSI	DEFL	in	(loc)	l/defl	L/d	PLATES	GRIP	
TCLL (roof)	20.0	Plate Grip DOL	1.15	TC	0.77	Vert(LL)	-0.07	7-8	>999	240	MT20	244/190
Snow (Pf)	20.0	Lumber DOL	1.15	BC	0.60	Vert(CT)	-0.12	7-8	>999	180		
TCDL	10.0	Rep Stress Incr	YES	WB	0.68	Horz(CT)	0.03	7	n/a	n/a		
BCLL	0.0*	Code	IRC2018/TPI2014	Matrix-MSH								
BCDL	10.0											
											Weight: 146 lb	FT = 20%

LUMBER
TOP CHORD 2x4 SP No.2
BOT CHORD 2x4 SP No.2
WEBS 2x4 SP No.3 *Except* 6-7:2x4 SP No.2
OTHERS 2x6 SP No.2
SLIDER Left 2x4 SP No.3 -- 1-6-0

BRACING
TOP CHORD Structural wood sheathing directly applied or 4-9-6 oc purlins, except end verticals.
BOT CHORD Rigid ceiling directly applied or 10-0-0 oc bracing.
WEBS 1 Row at midpt 6-7, 5-7

REACTIONS (size) 1=0-5-8, 7=0-3-0
Max Horiz 1=386 (LC 13)
Max Uplift 1=-78 (LC 14), 7=-178 (LC 14)
Max Grav 1=894 (LC 5), 7=1012 (LC 5)

FORCES (lb) - Maximum Compression/Maximum Tension
TOP CHORD 1-3=-1348/176, 3-5=-818/158, 5-6=-219/141, 6-7=-259/80
BOT CHORD 1-10=-302/1153, 8-10=-213/1153, 7-8=-110/648
WEBS 3-10=0/266, 3-8=-597/179, 5-8=-4/583, 5-7=-937/224

- TCLL: ASCE 7-16; Pr=20.0 psf (roof LL: Lum DOL=1.15 Plate DOL=1.15); Pf=20.0 psf (Lum DOL=1.15 Plate DOL=1.15); Is=1.0; Rough Cat B; Fully Exp.; Ce=0.9; Cs=1.00; Ct=1.10
 - Unbalanced snow loads have been considered for this design.
 - All plates are 3x5 MT20 unless otherwise indicated.
 - This truss has been designed for a 10.0 psf bottom chord live load nonconcurrent with any other live loads.
 - * This truss has been designed for a live load of 20.0psf on the bottom chord in all areas where a rectangle 3-06-00 tall by 2-00-00 wide will fit between the bottom chord and any other members, with BCDL = 10.0psf.
 - One H2.5A Simpson Strong-Tie connectors recommended to connect truss to bearing walls due to UPLIFT at jt(s) 7 and 1. This connection is for uplift only and does not consider lateral forces.
 - This truss is designed in accordance with the 2018 International Residential Code sections R502.11.1 and R802.10.2 and referenced standard ANSI/TPI 1.
- LOAD CASE(S)** Standard

NOTES
1) Wind: ASCE 7-16; Vult=130mph (3-second gust)
Vasd=103mph; TCDL=6.0psf; BCDL=6.0psf; h=25ft;
Cat. II; Exp B; Enclosed; MWFRS (envelope) exterior zone and C-C Exterior(2E) 0-0-0 to 3-0-0, Interior (1) 3-0-0 to 17-1-12, Exterior(2E) 17-1-12 to 20-1-12 zone; cantilever left and right exposed ; end vertical left and right exposed;C-C for members and forces & MWFRS for reactions shown; Lumber DOL=1.60 plate grip DOL=1.60

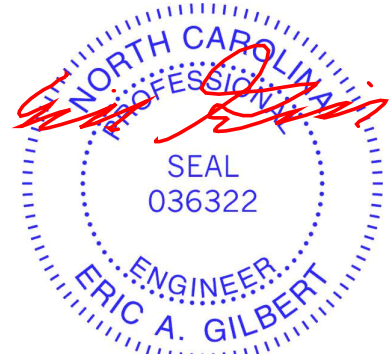

April 14, 2023

Job 23040053-01	Truss C3	Truss Type Jack-Closed	Qty 1	Ply 1	David Weekly-11 Serenity-Roof-B326 A Job Reference (optional)	I57767116
--------------------	-------------	---------------------------	----------	----------	--	-----------

Carter Components (Sanford), Sanford, NC - 27332,

Run: 8.53 S Mar 9 2023 Print: 8.530 S Mar 9 2023 MiTek Industries, Inc. Thu Apr 13 16:17:07
ID:Th_ZgqfOm8nUgyqbk?jKoVzRQuC-RfC?PsB70Hq3NSgPqnL8w3uTXbGKWrCDoi7J4zJc?

Page: 1

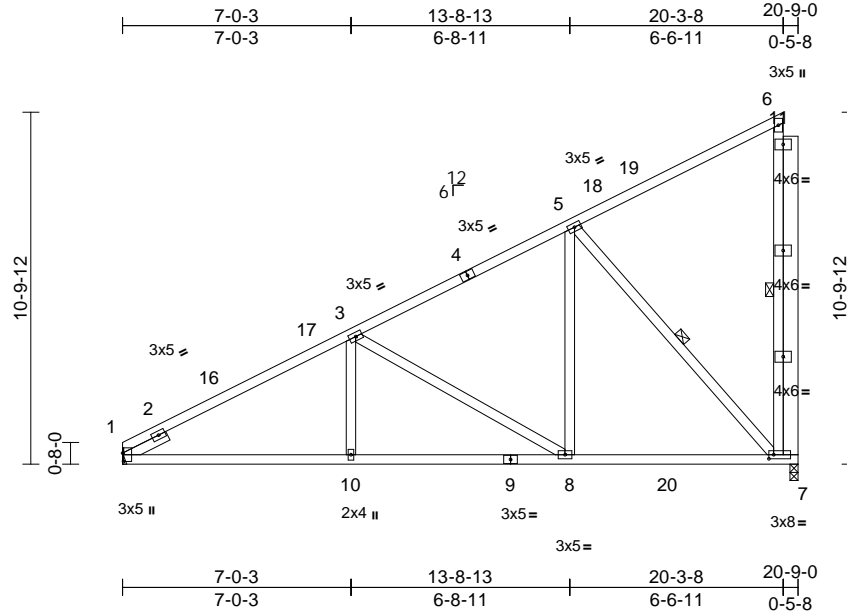

Scale = 1:70.8

Plate Offsets (X, Y): [1:0-3-1,0-0-5], [7:0-1-12,0-1-8]

Loading	(psf)	Spacing	2-0-0	CSI	DEFL	in	(loc)	l/defl	L/d	PLATES	GRIP	
TCLL (roof)	20.0	Plate Grip DOL	1.15	TC	0.77	Vert(LL)	-0.07	7-8	>999	240	MT20	244/190
Snow (Pf)	20.0	Lumber DOL	1.15	BC	0.60	Vert(CT)	-0.12	7-8	>999	180		
TCDL	10.0	Rep Stress Incr	YES	WB	0.68	Horz(CT)	0.03	7	n/a	n/a		
BCLL	0.0*	Code	IRC2018/TPI2014	Matrix-MSH								
BCDL	10.0											
											Weight: 146 lb	FT = 20%

LUMBER
TOP CHORD 2x4 SP No.2
BOT CHORD 2x4 SP No.2
WEBS 2x4 SP No.3 *Except* 6-7:2x4 SP No.2
OTHERS 2x6 SP No.2
SLIDER Left 2x4 SP No.3 -- 1-6-0

BRACING
TOP CHORD Structural wood sheathing directly applied or 4-9-6 oc purlins, except end verticals.
BOT CHORD Rigid ceiling directly applied or 10-0-0 oc bracing.
WEBS 1 Row at midpt 6-7, 5-7

REACTIONS (size) 1= Mechanical, 7=0-3-0
Max Horiz 1=386 (LC 13)
Max Uplift 1=-38 (LC 14), 7=-81 (LC 11)
Max Grav 1=894 (LC 5), 7=1012 (LC 5)

FORCES (lb) - Maximum Compression/Maximum Tension
TOP CHORD 1-3=-1348/123, 3-5=-818/131, 5-6=-219/140, 6-7=-259/80
BOT CHORD 1-10=-302/1153, 8-10=-158/1153, 7-8=-110/648
WEBS 3-10=0/266, 3-8=-597/124, 5-8=0/583, 5-7=-937/144

- TCLL: ASCE 7-16; Pr=20.0 psf (roof LL: Lum DOL=1.15 Plate DOL=1.15); Pf=20.0 psf (Lum DOL=1.15 Plate DOL=1.15); Is=1.0; Rough Cat B; Fully Exp.; Ce=0.9; Cs=1.00; Ct=1.10
- Unbalanced snow loads have been considered for this design.
- All plates are 3x5 MT20 unless otherwise indicated.
- This truss has been designed for a 10.0 psf bottom chord live load nonconcurrent with any other live loads.
- * This truss has been designed for a live load of 20.0psf on the bottom chord in all areas where a rectangle 3-06-00 tall by 2-00-00 wide will fit between the bottom chord and any other members, with BCDL = 10.0psf.
- Refer to girder(s) for truss to truss connections.
- Provide mechanical connection (by others) of truss to bearing plate capable of withstanding 38 lb uplift at joint 1.
- One H2.5A Simpson Strong-Tie connectors recommended to connect truss to bearing walls due to UPLIFT at jt(s) 7. This connection is for uplift only and does not consider lateral forces.
- This truss is designed in accordance with the 2018 International Residential Code sections R502.11.1 and R802.10.2 and referenced standard ANSI/TPI 1.

LOAD CASE(S) Standard

NOTES

- Wind: ASCE 7-16; Vult=130mph (3-second gust)
Vasd=103mph; TCDL=6.0psf; BCDL=6.0psf; h=25ft;
Cat. II; Exp B; Enclosed; MWFRS (envelope) exterior zone and C-C Exterior(2E) 0-0-0 to 3-0-0, Interior (1) 3-0-0 to 15-10-13, Exterior(2R) 15-10-13 to 20-1-12 zone; cantilever left and right exposed; end vertical left and right exposed; C-C for members and forces & MWFRS for reactions shown; Lumber DOL=1.60 plate grip DOL=1.60

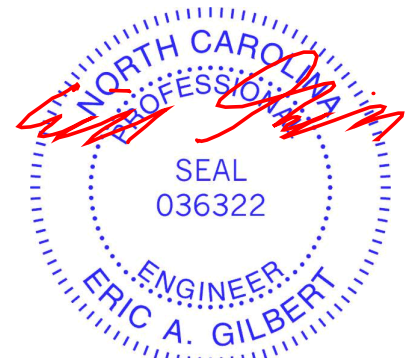

April 14, 2023

WARNING - Verify design parameters and READ NOTES ON THIS AND INCLUDED MITEK REFERENCE PAGE MII-7473 rev. 5/19/2020 BEFORE USE.

Design valid for use only with MiTek® connectors. This design is based only upon parameters shown, and is for an individual building component, not a truss system. Before use, the building designer must verify the applicability of design parameters and properly incorporate this design into the overall building design. Bracing indicated is to prevent buckling of individual truss web and/or chord members only. Additional temporary and permanent bracing is always required for stability and to prevent collapse with possible personal injury and property damage. For general guidance regarding the fabrication, storage, delivery, erection and bracing of trusses and truss systems, see **ANSI/TPI1 Quality Criteria, DSB-89 and BCSI Building Component Safety Information** available from Truss Plate Institute, 2670 Crain Highway, Suite 203 Waldorf, MD 20601



818 Soundside Road
Edenton, NC 27932

Job 23040053-01	Truss D1GE	Truss Type Common Supported Gable	Qty 1	Ply 1	David Weekly-11 Serenity-Roof-B326 A Job Reference (optional)	157767117
--------------------	---------------	--------------------------------------	----------	----------	--	-----------

Carter Components (Sanford), Sanford, NC - 27332,

Run: 8.53 S Mar 9 2023 Print: 8.530 S Mar 9 2023 MiTek Industries, Inc. Thu Apr 13 16:17:07
ID:8F2D?hHuvW?rb9K6OMB_Y2zRQRrE-RfC?PsB70Hq3NSgPqnL8w3uITXbGKWrCDoi7J4zJC?f

Page: 1

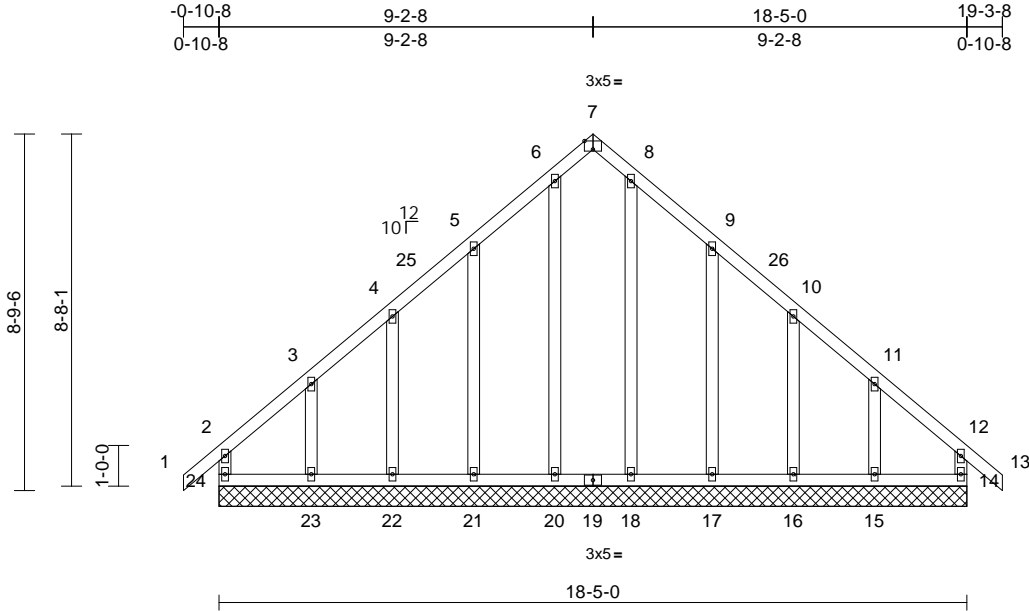

Scale = 1:56.8
Plate Offsets (X, Y): [7-0-2-8,Edge]

Loading	(psf)	Spacing	2-0-0	CSI	DEFL	in	(loc)	l/defl	L/d	PLATES	GRIP	
TCLL (roof)	20.0	Plate Grip DOL	1.15	TC	0.20	Vert(LL)	n/a	-	n/a	999	MT20	244/190
Snow (Pf)	20.0	Lumber DOL	1.15	BC	0.11	Vert(CT)	n/a	-	n/a	999		
TCDL	10.0	Rep Stress Incr	YES	WB	0.20	Horz(CT)	0.00	14	n/a	n/a		
BCLL	0.0*	Code	IRC2018/TPI2014	Matrix-MR								
BCDL	10.0											
											Weight: 126 lb	FT = 20%

LUMBER
TOP CHORD 2x4 SP No.2
BOT CHORD 2x4 SP No.2
WEBS 2x4 SP No.3
OTHERS 2x4 SP No.3

BRACING
TOP CHORD Structural wood sheathing directly applied or 6-0-0 oc purlins, except end verticals.
BOT CHORD Rigid ceiling directly applied or 6-0-0 oc bracing.

REACTIONS (size)
14=18-5-0, 15=18-5-0, 16=18-5-0, 17=18-5-0, 18=18-5-0, 20=18-5-0, 21=18-5-0, 22=18-5-0, 23=18-5-0, 24=18-5-0
Max Horiz 24=224 (LC 13)
Max Uplift 14=51 (LC 11), 15=161 (LC 15), 16=48 (LC 15), 17=115 (LC 15), 21=113 (LC 14), 22=47 (LC 14), 23=165 (LC 14), 24=70 (LC 10)
Max Grav 14=188 (LC 28), 15=221 (LC 25), 16=173 (LC 22), 17=255 (LC 22), 18=220 (LC 22), 20=220 (LC 21), 21=255 (LC 21), 22=173 (LC 21), 23=228 (LC 24), 24=204 (LC 25)

FORCES (lb) - Maximum Compression/Maximum Tension
TOP CHORD 2-24=-167/64, 1-2=0/39, 2-3=-160/139, 3-4=-104/92, 4-5=-91/131, 5-6=-132/248, 6-7=-99/177, 7-8=-99/177, 8-9=-132/248, 9-10=-76/131, 10-11=-89/73, 11-12=-146/116, 12-13=0/39, 12-14=-154/48
BOT CHORD 23-24=-105/169, 22-23=-105/169, 21-22=-105/169, 20-21=-105/169, 18-20=-105/169, 17-18=-105/169, 16-17=-105/169, 15-16=-105/169, 14-15=-105/169

WEBS
6-20=-182/14, 8-18=-182/14, 5-21=-215/162, 4-22=-134/92, 3-23=-161/164, 9-17=-215/162, 10-16=-134/92, 11-15=-157/164

- NOTES**
- Unbalanced roof live loads have been considered for this design.
 - Wind: ASCE 7-16; Vult=130mph (3-second gust) Vasd=103mph; TCDL=6.0psf; BCDL=6.0psf; h=25ft; Cat. II; Exp B; Enclosed; MWFRS (envelope) exterior zone and C-C Corner(3E) -0-10-8 to 2-3-4, Exterior(2N) 2-3-4 to 6-2-8, Corner(3R) 6-2-8 to 12-1-12, Exterior(2N) 12-1-12 to 16-1-12, Corner(3E) 16-1-12 to 19-3-8 zone; cantilever left and right exposed; end vertical left and right exposed; C-C for members and forces & MWFRS for reactions shown; Lumber DOL=1.60 plate grip DOL=1.60
 - Truss designed for wind loads in the plane of the truss only. For studs exposed to wind (normal to the face), see Standard Industry Gable End Details as applicable, or consult qualified building designer as per ANSI/TPI 1.
 - TCLL: ASCE 7-16; Pr=20.0 psf (roof LL: Lum DOL=1.15 Plate DOL=1.15); Pf=20.0 psf (Lum DOL=1.15 Plate DOL=1.15); Is=1.0; Rough Cat B; Fully Exp.; Ce=0.9; Cs=1.00; Ct=1.10
 - Unbalanced snow loads have been considered for this design.
 - This truss has been designed for greater of min roof live load of 12.0 psf or 1.00 times flat roof load of 20.0 psf on overhangs non-concurrent with other live loads.
 - All plates are 2x4 MT20 unless otherwise indicated.
 - Gable requires continuous bottom chord bearing.
 - Truss to be fully sheathed from one face or securely braced against lateral movement (i.e. diagonal web).
 - Gable studs spaced at 2-0-0 oc.
 - This truss has been designed for a 10.0 psf bottom chord live load nonconcurrent with any other live loads.

- * This truss has been designed for a live load of 20.0psf on the bottom chord in all areas where a rectangle 3-06-00 tall by 2-00-00 wide will fit between the bottom chord and any other members.
 - Provide mechanical connection (by others) of truss to bearing plate capable of withstanding 70 lb uplift at joint 24, 51 lb uplift at joint 14, 113 lb uplift at joint 21, 47 lb uplift at joint 22, 165 lb uplift at joint 23, 115 lb uplift at joint 17, 48 lb uplift at joint 16 and 161 lb uplift at joint 15.
 - This truss is designed in accordance with the 2018 International Residential Code sections R502.11.1 and R802.10.2 and referenced standard ANSI/TPI 1.
- LOAD CASE(S)** Standard

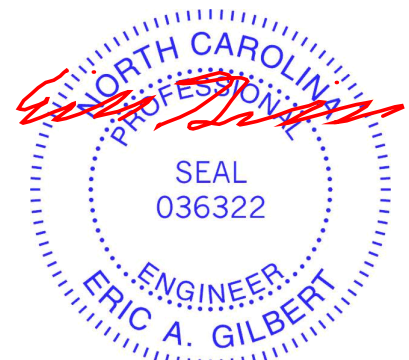

April 14, 2023

WARNING - Verify design parameters and READ NOTES ON THIS AND INCLUDED MITEK REFERENCE PAGE MII-7473 rev. 5/19/2020 BEFORE USE.

Design valid for use only with MiTek® connectors. This design is based only upon parameters shown, and is for an individual building component, not a truss system. Before use, the building designer must verify the applicability of design parameters and properly incorporate this design into the overall building design. Bracing indicated is to prevent buckling of individual truss web and/or chord members only. Additional temporary and permanent bracing is always required for stability and to prevent collapse with possible personal injury and property damage. For general guidance regarding the fabrication, storage, delivery, erection and bracing of trusses and truss systems, see **ANSI/TPI1 Quality Criteria, DSB-89 and BCSI Building Component Safety Information** available from Truss Plate Institute, 2670 Crain Highway, Suite 203 Waldorf, MD 20601



818 Soundside Road
Edenton, NC 27932

Job 23040053-01	Truss D1GR	Truss Type Common Girder	Qty 1	Ply 3	David Weekly-11 Serenity-Roof-B326 A Job Reference (optional)	I57767118
--------------------	---------------	-----------------------------	----------	----------	--	-----------

Carter Components (Sanford), Sanford, NC - 27332,

Run: 8.53 S Mar 9 2023 Print: 8.530 S Mar 9 2023 MiTek Industries, Inc. Thu Apr 13 16:17:09
ID:ahvae5BsMwascBuTkn6buzRAib-RfC?PsB70Hq3NSgPqnL8w3uITxbGKWrCDoi7J4zJC?F

Page: 1

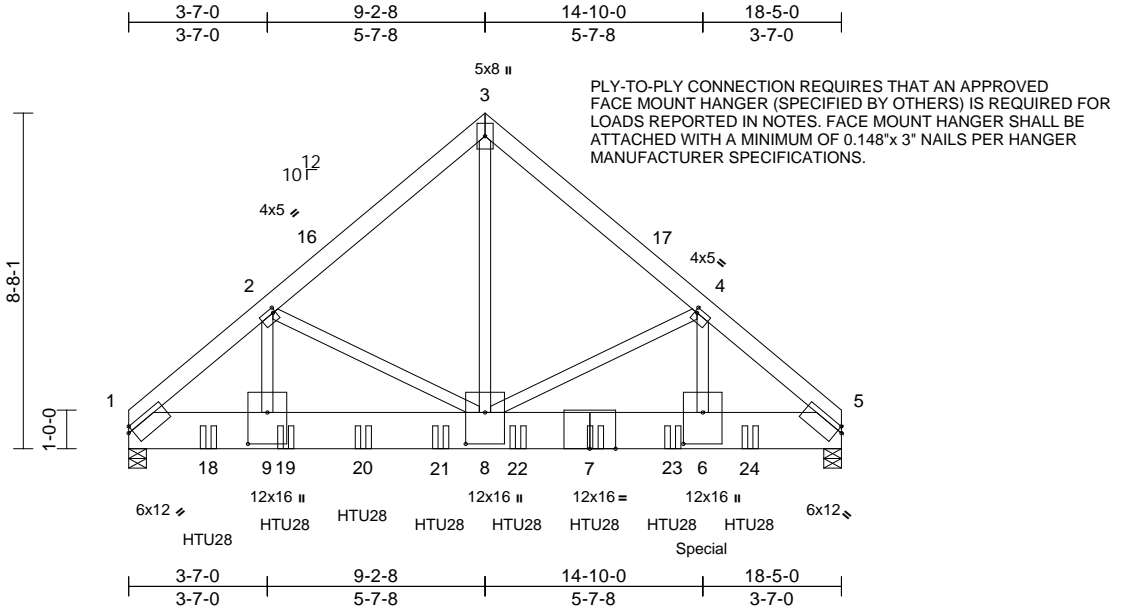

Scale = 1:59.5

Plate Offsets (X, Y): [1:Edge,0-1-9], [2:0-0-12,0-1-8], [4:0-0-12,0-1-8], [5:Edge,0-1-9], [6:0-9-12,0-6-0], [8:0-9-12,0-6-0], [9:0-9-12,0-6-0]

Loading	(psf)	Spacing	2-0-0	CSI	DEFL	in	(loc)	l/defl	L/d	PLATES	GRIP	
TCLL (roof)	20.0	Plate Grip DOL	1.15	TC	0.45	Vert(LL)	-0.10	6-8	>999	240	MT20	244/190
Snow (Pf)	20.0	Lumber DOL	1.15	BC	0.41	Vert(CT)	-0.17	6-8	>999	180		
TCDL	10.0	Rep Stress Incr	NO	WB	0.80	Horz(CT)	0.03	5	n/a	n/a		
BCLL	0.0*	Code	IRC2018/TPI2014	Matrix-MSH								
BCDL	10.0											
											Weight: 545 lb	FT = 20%

LUMBER	
TOP CHORD	2x6 SP No.2
BOT CHORD	2x12 SP 2400F 2.0E
WEBS	2x4 SP No.2 *Except* 8-3:2x4 SP No.1, 2-8,4-8:2x4 SP No.3
BRACING	
TOP CHORD	Structural wood sheathing directly applied or 6-0-0 oc purlins.
BOT CHORD	Rigid ceiling directly applied or 10-0-0 oc bracing.
REACTIONS	
(size)	1=0-5-8, 5=0-5-8
Max Horiz	1=-180 (LC 10)
Max Grav	1=11402 (LC 5), 5=15008 (LC 22)
FORCES	
	(lb) - Maximum Compression/Maximum Tension
TOP CHORD	1-2=-14037/0, 2-3=-11369/0, 3-4=-11356/0, 4-5=-18724/0
BOT CHORD	1-9=0/10670, 8-9=0/10670, 6-8=0/14249, 5-6=0/14249
WEBS	3-8=0/13969, 4-6=0/8263, 2-9=0/2808, 2-8=-2269/0, 4-8=-6711/164

- NOTES**
- N/A
 - 3-ply truss to be connected together with 10d (0.131"x3") nails as follows:
Top chords connected as follows: 2x6 - 2 rows staggered at 0-9-0 oc.
Bottom chords connected as follows: 2x12 - 6 rows staggered at 0-4-0 oc.
Web connected as follows: 2x4 - 2 rows staggered at 0-4-0 oc.
 - All loads are considered equally applied to all plies, except if noted as front (F) or back (B) face in the LOAD CASE(S) section. Ply to ply connections have been provided to distribute only loads noted as (F) or (B), unless otherwise indicated.

- Unbalanced roof live loads have been considered for this design.
- Wind: ASCE 7-16; Vult=130mph (3-second gust) Vasd=103mph; TC DL=6.0psf; BCDL=6.0psf; h=25ft; Cat. II; Exp B; Enclosed; MWFRS (envelope) exterior zone; cantilever left and right exposed; end vertical left and right exposed; Lumber DOL=1.60 plate grip DOL=1.60
- TCLL: ASCE 7-16; Pr=20.0 psf (roof LL: Lum DOL=1.15 Plate DOL=1.15); Pf=20.0 psf (Lum DOL=1.15 Plate DOL=1.15); Is=1.0; Rough Cat B; Fully Exp.; Ce=0.9; Cs=1.00; Ct=1.10
- Unbalanced snow loads have been considered for this design.
- This truss has been designed for a 10.0 psf bottom chord live load nonconcurrent with any other live loads.
- * This truss has been designed for a live load of 20.0psf on the bottom chord in all areas where a rectangle 3-06-00 tall by 2-00-00 wide will fit between the bottom chord and any other members.
- This truss is designed in accordance with the 2018 International Residential Code sections R502.11.1 and R802.10.2 and referenced standard ANSI/TPI 1.
- Use Simpson Strong-Tie HTU28 (26-10d Girder, 14-10dx1 1/2 Truss, Single Ply Girder) or equivalent spaced at 2-0-0 oc max. starting at 2-0-12 from the left end to 16-0-12 to connect truss(es) to front face of bottom chord.
- Fill all nail holes where hanger is in contact with lumber.
- Hanger(s) or other connection device(s) shall be provided sufficient to support concentrated load(s) 8726 lb down and 630 lb up at 14-10-0 on bottom chord. The design/selection of such connection device(s) is the responsibility of others.

LOAD CASE(S) Standard
1) Dead + Snow (balanced): Lumber Increase=1.15, Plate Increase=1.15

Uniform Loads (lb/ft)
Vert: 1-3=-60, 3-5=-60, 10-13=-20
Concentrated Loads (lb)
Vert: 7=-1916 (F), 6=-5454 (F), 18=-1916 (F), 19=-1916 (F), 20=-1916 (F), 21=-1916 (F), 22=-1916 (F), 23=-1916 (F), 24=-818 (F)

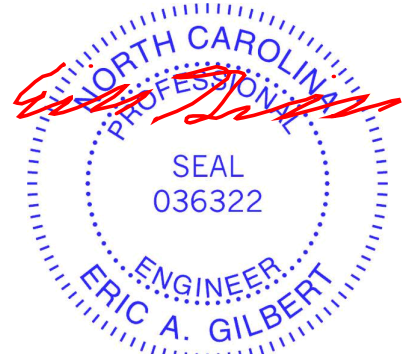

April 14, 2023

WARNING - Verify design parameters and READ NOTES ON THIS AND INCLUDED MITEK REFERENCE PAGE MII-7473 rev. 5/19/2020 BEFORE USE.

Design valid for use only with MiTek® connectors. This design is based only upon parameters shown, and is for an individual building component, not a truss system. Before use, the building designer must verify the applicability of design parameters and properly incorporate this design into the overall building design. Bracing indicated is to prevent buckling of individual truss web and/or chord members only. Additional temporary and permanent bracing is always required for stability and to prevent collapse with possible personal injury and property damage. For general guidance regarding the fabrication, storage, delivery, erection and bracing of trusses and truss systems, see **ANSI/TPI1 Quality Criteria, DSB-89 and BCSI Building Component Safety Information** available from Truss Plate Institute, 2670 Crain Highway, Suite 203 Waldorf, MD 20601



818 Soundside Road
Edenton, NC 27932

Job 23040053-01	Truss E1GE	Truss Type Common Supported Gable	Qty 1	Ply 1	David Weekly-11 Serenity-Roof-B326 A Job Reference (optional)	157767119
--------------------	---------------	--------------------------------------	----------	----------	--	-----------

Carter Components (Sanford), Sanford, NC - 27332,

Run: 8.53 S Mar 9 2023 Print: 8.530 S Mar 9 2023 MiTek Industries, Inc. Thu Apr 13 16:17:09
ID:XFVx5DgSDeEi7jgY6wjof?zRQtJ-RfC?PsB70Hq3NSgPqnL8w3u1TXbGKWrCdoi7J4zJC?f

Page: 1

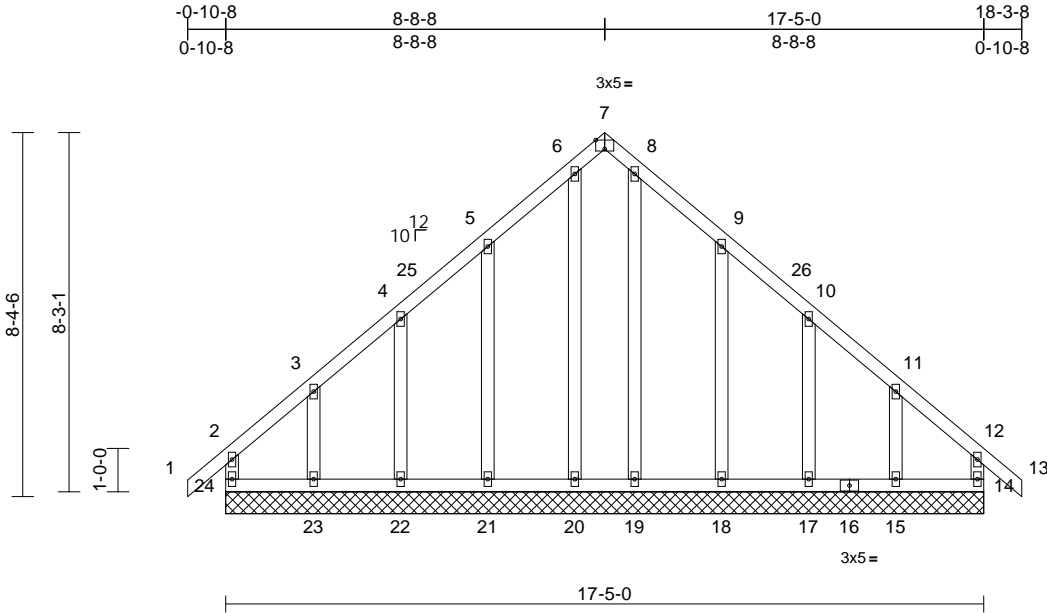

Scale = 1:52.9

Plate Offsets (X, Y): [7:0-2-8,Edge]

Loading	(psf)	Spacing	2-0-0	CSI	DEFL	in	(loc)	l/defl	L/d	PLATES	GRIP	
TCLL (roof)	20.0	Plate Grip DOL	1.15	TC	0.18	Vert(LL)	n/a	-	n/a	999	MT20	244/190
Snow (Pf)	20.0	Lumber DOL	1.15	BC	0.09	Vert(CT)	n/a	-	n/a	999		
TCDL	10.0	Rep Stress Incr	YES	WB	0.17	Horz(CT)	0.00	14	n/a	n/a		
BCLL	0.0*	Code	IRC2018/TPI2014	Matrix-MR								
BCDL	10.0											
											Weight: 121 lb	FT = 20%

LUMBER	
TOP CHORD	2x4 SP No.2
BOT CHORD	2x4 SP No.2
WEBS	2x4 SP No.3
OTHERS	2x4 SP No.3

BRACING	
TOP CHORD	Structural wood sheathing directly applied or 6-0-0 oc purlins, except end verticals.
BOT CHORD	Rigid ceiling directly applied or 6-0-0 oc bracing.

REACTIONS (size)	
14=17-5-0, 15=17-5-0, 17=17-5-0, 18=17-5-0, 19=17-5-0, 20=17-5-0, 21=17-5-0, 22=17-5-0, 23=17-5-0, 24=17-5-0	
Max Horiz	24=214 (LC 12)
Max Uplift	14=60 (LC 11), 15=143 (LC 15), 17=57 (LC 15), 18=103 (LC 15), 21=102 (LC 14), 22=56 (LC 14), 23=149 (LC 14), 24=83 (LC 10)
Max Grav	14=174 (LC 24), 15=208 (LC 29), 17=184 (LC 22), 18=263 (LC 22), 19=197 (LC 22), 20=197 (LC 21), 21=263 (LC 21), 22=184 (LC 21), 23=217 (LC 28), 24=192 (LC 29)

FORCES (lb) - Maximum Compression/Maximum Tension	
TOP CHORD	2-24=-156/73, 1-2=0/39, 2-3=-146/137, 3-4=-98/98, 4-5=-82/166, 5-6=-137/277, 6-7=-98/193, 7-8=-98/193, 8-9=-137/277, 9-10=-82/166, 10-11=-77/84, 11-12=-122/111, 12-13=0/39, 12-14=-141/58
BOT CHORD	23-24=-101/140, 22-23=-101/140, 21-22=-101/140, 20-21=-101/140, 19-20=-101/140, 18-19=-101/140, 17-18=-101/140, 15-17=-101/140, 14-15=-101/140

WEBS	
6-20=-164/22, 8-19=-164/22, 5-21=-222/151, 4-22=-144/105, 3-23=-151/148, 9-18=-222/151, 10-17=-144/105, 11-15=-147/148	

NOTES

- Unbalanced roof live loads have been considered for this design.
- Wind: ASCE 7-16; Vult=130mph (3-second gust) Vasd=103mph; TCDL=6.0psf; BCDL=6.0psf; h=25ft; Cat. II; Exp B; Enclosed; MWFRS (envelope) exterior zone and C-C Corner(3E) -0-10-8 to 2-0-4, Exterior(2N) 2-0-4 to 5-8-8, Corner(3R) 5-8-8 to 11-8-8, Exterior(2N) 11-8-8 to 15-3-8, Corner(3E) 15-3-8 to 18-3-8 zone; cantilever left and right exposed; end vertical left and right exposed; C-C for members and forces & MWFRS for reactions shown; Lumber DOL=1.60 plate grip DOL=1.60
- Truss designed for wind loads in the plane of the truss only. For studs exposed to wind (normal to the face), see Standard Industry Gable End Details as applicable, or consult qualified building designer as per ANSI/TPI 1.
- TCLL: ASCE 7-16; Pr=20.0 psf (roof LL: Lum DOL=1.15 Plate DOL=1.15); Pf=20.0 psf (Lum DOL=1.15 Plate DOL=1.15); Is=1.0; Rough Cat B; Fully Exp.; Ce=0.9; Cs=1.00; Ct=1.10
- Unbalanced snow loads have been considered for this design.
- This truss has been designed for greater of min roof live load of 12.0 psf or 1.00 times flat roof load of 20.0 psf on overhangs non-concurrent with other live loads.
- All plates are 2x4 MT20 unless otherwise indicated.
- Gable requires continuous bottom chord bearing.
- Truss to be fully sheathed from one face or securely braced against lateral movement (i.e. diagonal web).
- Gable studs spaced at 2-0-0 oc.
- This truss has been designed for a 10.0 psf bottom chord live load nonconcurrent with any other live loads.

- * This truss has been designed for a live load of 20.0psf on the bottom chord in all areas where a rectangle 3-06-00 tall by 2-00-00 wide will fit between the bottom chord and any other members.
- Provide mechanical connection (by others) of truss to bearing plate capable of withstanding 83 lb uplift at joint 24, 60 lb uplift at joint 14, 102 lb uplift at joint 21, 56 lb uplift at joint 22, 149 lb uplift at joint 23, 103 lb uplift at joint 18, 57 lb uplift at joint 17 and 143 lb uplift at joint 15.
- This truss is designed in accordance with the 2018 International Residential Code sections R502.11.1 and R802.10.2 and referenced standard ANSI/TPI 1.

LOAD CASE(S) Standard

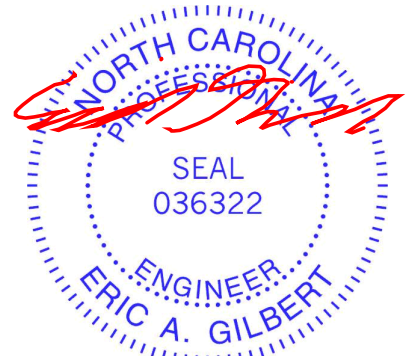

April 14, 2023

WARNING - Verify design parameters and READ NOTES ON THIS AND INCLUDED MITEK REFERENCE PAGE MII-7473 rev. 5/19/2020 BEFORE USE.

Design valid for use only with MiTek® connectors. This design is based only upon parameters shown, and is for an individual building component, not a truss system. Before use, the building designer must verify the applicability of design parameters and properly incorporate this design into the overall building design. Bracing indicated is to prevent buckling of individual truss web and/or chord members only. Additional temporary and permanent bracing is always required for stability and to prevent collapse with possible personal injury and property damage. For general guidance regarding the fabrication, storage, delivery, erection and bracing of trusses and truss systems, see **ANSI/TPI1 Quality Criteria, DSB-89 and BCSI Building Component Safety Information** available from Truss Plate Institute, 2670 Crain Highway, Suite 203 Waldorf, MD 20601



818 Soundside Road
Edenton, NC 27932

Job 23040053-01	Truss F1	Truss Type Common	Qty 6	Ply 1	David Weekly-11 Serenity-Roof-B326 A Job Reference (optional)	157767120
--------------------	-------------	----------------------	----------	----------	--	-----------

Carter Components (Sanford), Sanford, NC - 27332,

Run: 8.53 S Mar 9 2023 Print: 8.530 S Mar 9 2023 MiTek Industries, Inc. Thu Apr 13 16:17:11
ID:yPXMLbyKekkHSiWSIZLGINzRR58-RfC?PsB70Hq3NSgPqnL8w3uITXbGKwRCDoi7J4zJC?f

Page: 1

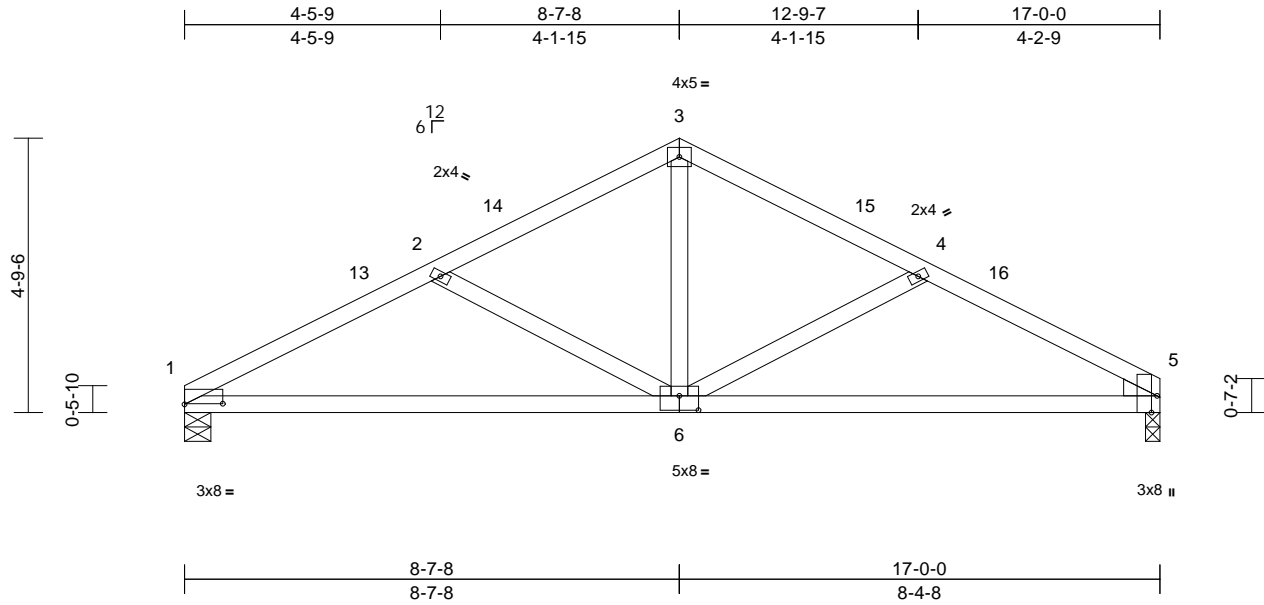

Scale = 1:40.2
Plate Offsets (X, Y): [1:0-8-0,0-0-2], [5:0-3-8,Edge], [6:0-4-0,0-3-0]

Loading	(psf)	Spacing	2-0-0	CSI	DEFL	in	(loc)	l/defl	L/d	PLATES	GRIP	
TCLL (roof)	20.0	Plate Grip DOL	1.15	TC	0.38	Vert(LL)	-0.09	6-9	>999	240	MT20	244/190
Snow (Pf)	20.0	Lumber DOL	1.15	BC	0.64	Vert(CT)	-0.19	6-9	>999	180		
TCDL	10.0	Rep Stress Incr	YES	WB	0.21	Horz(CT)	0.02	5	n/a	n/a		
BCLL	0.0*	Code	IRC2018/TPI2014	Matrix-MSH								
BCDL	10.0											
											Weight: 75 lb	FT = 20%

LUMBER
TOP CHORD 2x4 SP No.2
BOT CHORD 2x4 SP No.2
WEBS 2x4 SP No.3
WEDGE Right: 2x4 SP No.3

BRACING
TOP CHORD Structural wood sheathing directly applied or 5-1-8 oc purlins.
BOT CHORD Rigid ceiling directly applied or 10-0-0 oc bracing.

REACTIONS (size) 1=0-5-8, 5=0-3-0
Max Horiz 1=71 (LC 14)
Max Uplift 1=-66 (LC 14), 5=-64 (LC 15)
Max Grav 1=745 (LC 20), 5=745 (LC 21)

FORCES (lb) - Maximum Compression/Maximum Tension
TOP CHORD 1-2=-1260/310, 2-3=-879/232, 3-4=-871/231, 4-5=-1209/300
BOT CHORD 1-5=-223/1089
WEBS 3-6=-52/475, 4-6=-399/159, 2-6=-445/175

- Unbalanced snow loads have been considered for this design.
- This truss has been designed for a 10.0 psf bottom chord live load nonconcurrent with any other live loads.
- * This truss has been designed for a live load of 20.0psf on the bottom chord in all areas where a rectangle 3-06-00 tall by 2-00-00 wide will fit between the bottom chord and any other members.
- One H2.5A Simpson Strong-Tie connectors recommended to connect truss to bearing walls due to UPLIFT at jt(s) 1 and 5. This connection is for uplift only and does not consider lateral forces.
- This truss is designed in accordance with the 2018 International Residential Code sections R502.11.1 and R802.10.2 and referenced standard ANSI/TPI 1.

LOAD CASE(S) Standard

- NOTES**
- Unbalanced roof live loads have been considered for this design.
 - Wind: ASCE 7-16; Vult=130mph (3-second gust) Vasd=103mph; TCDL=6.0psf; BCDL=6.0psf; h=25ft; Cat. II; Exp B; Enclosed; MWFRS (envelope) exterior zone and C-C Exterior(2E) 0-0-0 to 3-0-0, Interior (1) 3-0-0 to 5-7-8, Exterior(2R) 5-7-8 to 11-7-8, Interior (1) 11-7-8 to 14-0-0, Exterior(2E) 14-0-0 to 17-0-0 zone; cantilever left and right exposed; end vertical left and right exposed; C-C for members and forces & MWFRS for reactions shown; Lumber DOL=1.60 plate grip DOL=1.60
 - TCLL: ASCE 7-16; Pr=20.0 psf (roof LL); Lum DOL=1.15 Plate DOL=1.15; Pf=20.0 psf (Lum DOL=1.15 Plate DOL=1.15); Is=1.0; Rough Cat B; Fully Exp.; Ce=0.9; Cs=1.00; Ct=1.10

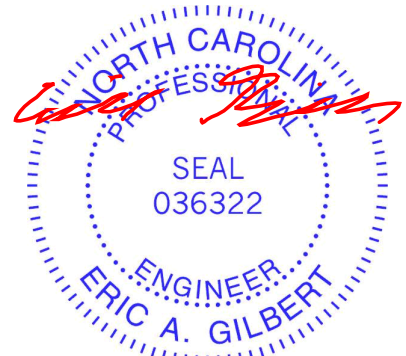

April 14, 2023

WARNING - Verify design parameters and READ NOTES ON THIS AND INCLUDED MITEK REFERENCE PAGE MII-7473 rev. 5/19/2020 BEFORE USE.

Design valid for use only with MiTek® connectors. This design is based only upon parameters shown, and is for an individual building component, not a truss system. Before use, the building designer must verify the applicability of design parameters and properly incorporate this design into the overall building design. Bracing indicated is to prevent buckling of individual truss web and/or chord members only. Additional temporary and permanent bracing is always required for stability and to prevent collapse with possible personal injury and property damage. For general guidance regarding the fabrication, storage, delivery, erection and bracing of trusses and truss systems, see ANSITPI1 Quality Criteria, DSB-89 and BCSI Building Component Safety Information available from Truss Plate Institute, 2670 Crain Highway, Suite 203 Waldorf, MD 20601



818 Soundside Road
Edenton, NC 27932

Job 23040053-01	Truss G1	Truss Type Monopitch	Qty 6	Ply 1	David Weekly-11 Serenity-Roof-B326 A Job Reference (optional)	157767121
--------------------	-------------	-------------------------	----------	----------	--	-----------

Carter Components (Sanford), Sanford, NC - 27332,

Run: 8.53 S Mar 9 2023 Print: 8.530 S Mar 9 2023 MiTek Industries, Inc. Thu Apr 13 16:17:12
ID: PdAAD85_ICJN?UaWrZnF5zRQu2-RfC?PsB70Hq3NSgPqnL8w3uITXbGKWRCDoi7J4zJC?f

Page: 1

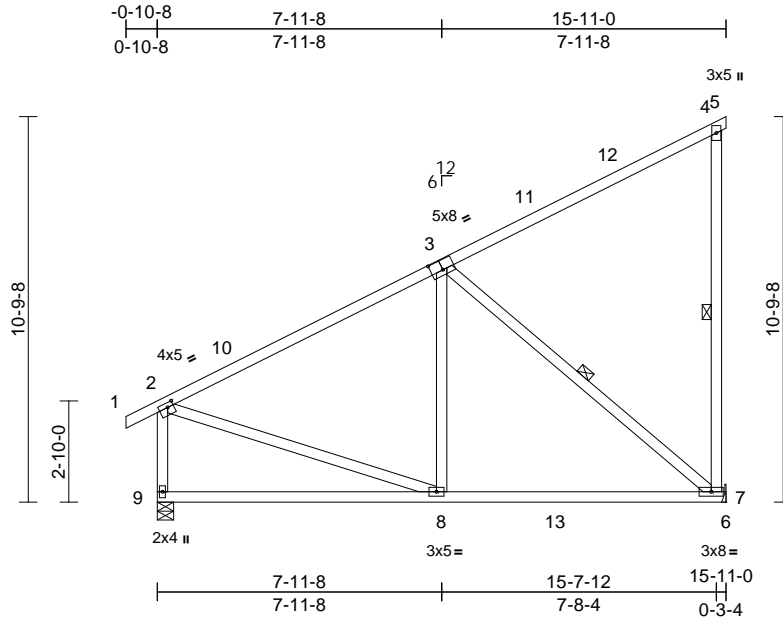

Scale = 1:64.5

Plate Offsets (X, Y): [2:0-2:0,0-1-8], [3:0-4:0,0-3-4]

Loading	(psf)	Spacing	2-0-0	CSI	DEFL	in	(loc)	l/defl	L/d	PLATES	GRIP	
TCLL (roof)	20.0	Plate Grip DOL	1.15	TC	0.94	Vert(LL)	-0.12	7-8	>999	240	MT20	244/190
Snow (Pf)	20.0	Lumber DOL	1.15	BC	0.67	Vert(CT)	-0.20	7-8	>931	180		
TCDL	10.0	Rep Stress Incr	YES	WB	0.36	Horz(CT)	-0.01	7	n/a	n/a		
BCLL	0.0*	Code	IRC2018/TPI2014	Matrix-MSH								
BCDL	10.0											
											Weight: 106 lb	FT = 20%

LUMBER

TOP CHORD 2x4 SP No.1 *Except* 1-3:2x4 SP No.2
 BOT CHORD 2x4 SP No.2
 WEBS 2x4 SP No.3 *Except* 4-7:2x4 SP No.2

BRACING

TOP CHORD Structural wood sheathing directly applied or 2-2-0 oc purlins, except end verticals.
 BOT CHORD Rigid ceiling directly applied or 9-1-3 oc bracing.
 WEBS 1 Row at midpt 4-7, 3-7

REACTIONS (size) 7= Mechanical, 9=0-5-8
 Max Horiz 9=272 (LC 14)
 Max Uplift 7=221 (LC 14)
 Max Grav 7=829 (LC 5), 9=752 (LC 5)

FORCES (lb) - Maximum Compression/Maximum Tension
 TOP CHORD 1-2=0/27, 2-4=-671/119, 4-5=-12/0, 4-7=-328/122, 2-9=-643/73
 BOT CHORD 8-9=-407/211, 7-8=-210/535, 6-7=0/0
 WEBS 3-8=0/312, 3-7=-675/269, 2-8=0/486

- This truss has been designed for greater of min roof live load of 12.0 psf or 1.00 times flat roof load of 20.0 psf on overhangs non-concurrent with other live loads.
- This truss has been designed for a 10.0 psf bottom chord live load nonconcurrent with any other live loads.
- * This truss has been designed for a live load of 20.0psf on the bottom chord in all areas where a rectangle 3-06-00 tall by 2-00-00 wide will fit between the bottom chord and any other members, with BCDL = 10.0psf.
- Refer to girder(s) for truss to truss connections.
- Provide mechanical connection (by others) of truss to bearing plate capable of withstanding 221 lb uplift at joint 7.
- This truss is designed in accordance with the 2018 International Residential Code sections R502.11.1 and R802.10.2 and referenced standard ANSI/TPI 1.

LOAD CASE(S) Standard

- NOTES**
- Wind: ASCE 7-16; Vult=130mph (3-second gust) Vasd=103mph; TCDL=6.0psf; BCDL=6.0psf; h=25ft; Cat. II; Exp B; Enclosed; MWFRS (envelope) exterior zone and C-C Exterior(2E) -0-10-8 to 2-1-8, Interior (1) 2-1-8 to 12-11-0, Exterior(2E) 12-11-0 to 15-11-0 zone; cantilever left and right exposed ; end vertical left exposed;C-C for members and forces & MWFRS for reactions shown; Lumber DOL=1.60 plate grip DOL=1.60
 - TCLL: ASCE 7-16; Pr=20.0 psf (roof LL: Lum DOL=1.15 Plate DOL=1.15); Pf=20.0 psf (Lum DOL=1.15 Plate DOL=1.15); Is=1.0; Rough Cat B; Fully Exp.; Ce=0.9; Cs=1.00; Ct=1.10
 - Unbalanced snow loads have been considered for this design.

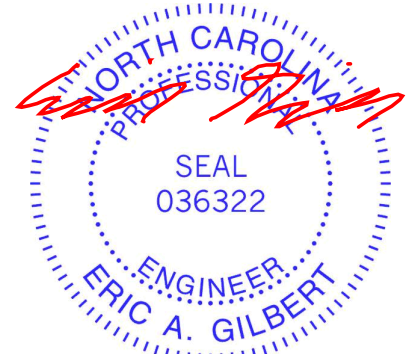

April 14, 2023

WARNING - Verify design parameters and READ NOTES ON THIS AND INCLUDED MITEK REFERENCE PAGE MII-7473 rev. 5/19/2020 BEFORE USE.
 Design valid for use only with MiTek® connectors. This design is based only upon parameters shown, and is for an individual building component, not a truss system. Before use, the building designer must verify the applicability of design parameters and properly incorporate this design into the overall building design. Bracing indicated is to prevent buckling of individual truss web and/or chord members only. Additional temporary and permanent bracing is always required for stability and to prevent collapse with possible personal injury and property damage. For general guidance regarding the fabrication, storage, delivery, erection and bracing of trusses and truss systems, see **ANSI/TPI1 Quality Criteria, DSB-89 and BCSI Building Component Safety Information** available from Truss Plate Institute, 2670 Crain Highway, Suite 203 Waldorf, MD 20601

ENGINEERING BY
TRENCO
 A MiTek Affiliate
 818 Soundside Road
 Edenton, NC 27932

Job 23040053-01	Truss H1	Truss Type Monopitch	Qty 6	Ply 1	David Weekly-11 Serenity-Roof-B326 A Job Reference (optional)	157767122
--------------------	-------------	-------------------------	----------	----------	--	-----------

Carter Components (Sanford), Sanford, NC - 27332,

Run: 8.53 S Mar 9 2023 Print: 8.530 S Mar 9 2023 MiTek Industries, Inc. Thu Apr 13 16:17:13
ID:nLPVeuW3K4TytrtY3ILLguzRRHK-RfC?PsB70Hq3NSgPqnL8w3uITXbGKwRCDoi7J4zJC7f

Page: 1

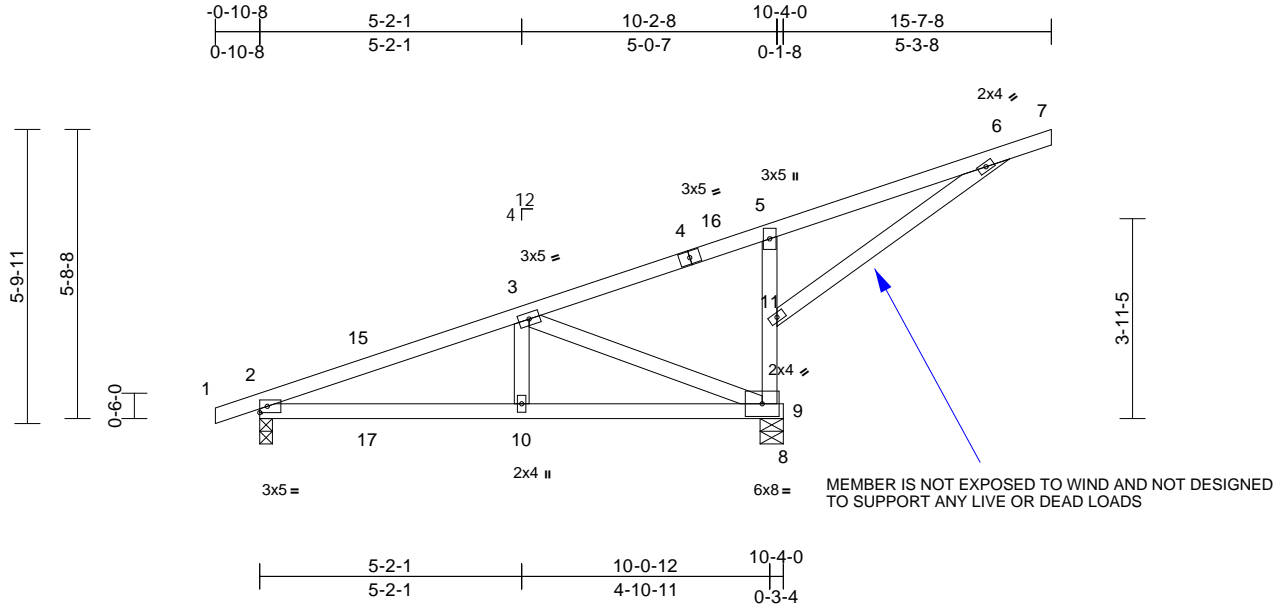

Loading	(psf)	Spacing	2-0-0	CSI	DEFL	in	(loc)	l/defl	L/d	PLATES	GRIP
TCLL (roof)	20.0	Plate Grip DOL	1.15	TC	0.85	Vert(LL)	0.05	10-14	>999	240	244/190
Snow (Pf)	20.0	Lumber DOL	1.15	BC	0.38	Vert(CT)	-0.05	9-10	>999	180	
TCDL	10.0	Rep Stress Incr	YES	WB	0.45	Horz(CT)	-0.01	9	n/a	n/a	
BCLL	0.0*	Code	IRC2018/TPI2014	Matrix-MSH							
BCDL	10.0									Weight: 64 lb	FT = 20%

LUMBER
TOP CHORD 2x4 SP No.2
BOT CHORD 2x4 SP No.2
WEBS 2x4 SP No.3 *Except* 5-9:2x4 SP No.1

BRACING
TOP CHORD Structural wood sheathing directly applied or 6-0-0 oc purlins, except end verticals. Except: 4-10-0 oc bracing: 9-11
BOT CHORD Rigid ceiling directly applied or 7-8-0 oc bracing.

REACTIONS (size) 2=0-3-0, 9=0-5-8
Max Horiz 2=170 (LC 10)
Max Uplift 2=-100 (LC 10), 9=-365 (LC 10)
Max Grav 2=365 (LC 1), 9=1064 (LC 21)

FORCES (lb) - Maximum Compression/Maximum Tension
TOP CHORD 1-2=0/17, 2-3=-428/406, 3-5=-321/423, 5-6=-432/729, 6-7=-25/0, 9-11=-824/432, 5-11=-362/180
BOT CHORD 2-10=-540/377, 9-10=-540/377, 8-9=0/0
WEBS 3-10=-337/227, 3-9=-632/809, 6-11=-790/431

- 4) This truss has been designed for greater of min roof live load of 12.0 psf or 1.00 times flat roof load of 20.0 psf on overhangs non-concurrent with other live loads.
- 5) This truss has been designed for a 10.0 psf bottom chord live load nonconcurrent with any other live loads.
- 6) * This truss has been designed for a live load of 20.0psf on the bottom chord in all areas where a rectangle 3-06-00 tall by 2-00-00 wide will fit between the bottom chord and any other members.
- 7) One H2.5A Simpson Strong-Tie connectors recommended to connect truss to bearing walls due to UPLIFT at jt(s) 2 and 9. This connection is for uplift only and does not consider lateral forces.
- 8) This truss is designed in accordance with the 2018 International Residential Code sections R502.11.1 and R802.10.2 and referenced standard ANSI/TPI 1.
- LOAD CASE(S)** Standard

- NOTES**
- 1) Wind: ASCE 7-16; Vult=130mph (3-second gust)
Vasd=103mph; TCDL=6.0psf; BCDL=6.0psf; h=25ft; Cat. II; Exp B; Enclosed; MWFRS (envelope) exterior zone and C-C Exterior(2E) -0-10-8 to 2-1-8, Interior (1) 2-1-8 to 15-7-8 zone; cantilever left and right exposed ; end vertical left and right exposed; porch left and right exposed;C-C for members and forces & MWFRS for reactions shown; Lumber DOL=1.60 plate grip DOL=1.60
 - 2) TCLL: ASCE 7-16; Pr=20.0 psf (roof LL: Lum DOL=1.15 Plate DOL=1.15); Pf=20.0 psf (Lum DOL=1.15 Plate DOL=1.15); Is=1.0; Rough Cat B; Fully Exp.; Ce=0.9; Cs=1.00; Ct=1.10
 - 3) Unbalanced snow loads have been considered for this design.

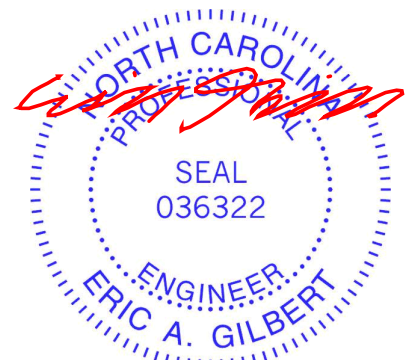

April 14, 2023

WARNING - Verify design parameters and READ NOTES ON THIS AND INCLUDED MITEK REFERENCE PAGE MII-7473 rev. 5/19/2020 BEFORE USE.
Design valid for use only with MiTek® connectors. This design is based only upon parameters shown, and is for an individual building component, not a truss system. Before use, the building designer must verify the applicability of design parameters and properly incorporate this design into the overall building design. Bracing indicated is to prevent buckling of individual truss web and/or chord members only. Additional temporary and permanent bracing is always required for stability and to prevent collapse with possible personal injury and property damage. For general guidance regarding the fabrication, storage, delivery, erection and bracing of trusses and truss systems, see **ANSI/TPI1 Quality Criteria, DSB-89 and BCSI Building Component Safety Information** available from Truss Plate Institute, 2670 Crain Highway, Suite 203 Waldorf, MD 20601



Job 23040053-01	Truss H1GE	Truss Type Monopitch Supported Gable	Qty 2	Ply 1	David Weekly-11 Serenity-Roof-B326 A Job Reference (optional)	I57767123
--------------------	---------------	---	----------	----------	--	-----------

Carter Components (Sanford), Sanford, NC - 27332,

Run: 8.53 S Mar 9 2023 Print: 8.530 S Mar 9 2023 MiTek Industries, Inc. Thu Apr 13 16:17:13
ID:kX6Xm09JsM8Rk_RkgNonK3zRRGV-RfC?PsB70Hq3NSgPqnL8w3uITxBGKWRcDoi7J4zJC?f

Page: 1

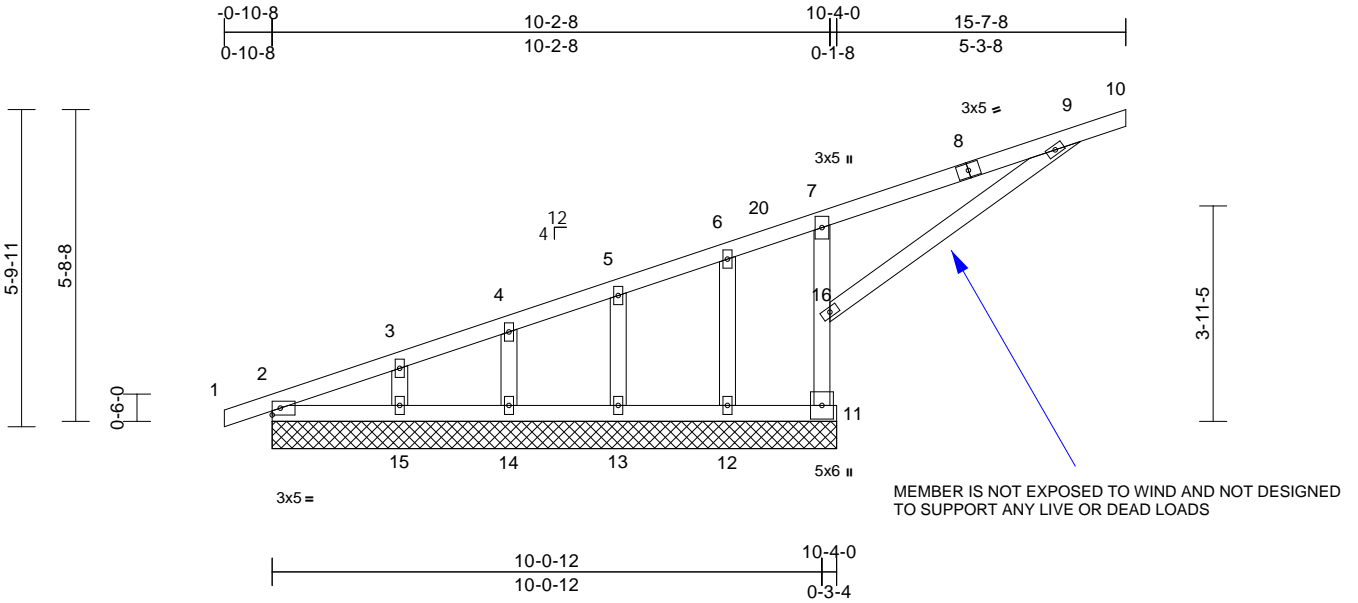

Scale = 1:42.2

Loading	(psf)	Spacing	2-0-0	CSI	DEFL	in	(loc)	l/defl	L/d	PLATES	GRIP
TCLL (roof)	20.0	Plate Grip DOL	1.15	TC	0.85	Vert(LL)	n/a	-	999	MT20	244/190
Snow (Pf)	20.0	Lumber DOL	1.15	BC	0.34	Vert(CT)	n/a	-	999		
TCDL	10.0	Rep Stress Incr	YES	WB	0.44	Horz(CT)	-0.01	11	n/a		
BCLL	0.0*	Code	IRC2018/TPI2014	Matrix-MSH							
BCDL	10.0									Weight: 65 lb	FT = 20%

LUMBER
TOP CHORD 2x4 SP No.2
BOT CHORD 2x4 SP No.2
WEBS 2x4 SP No.1 *Except* 16-9:2x4 SP No.3
OTHERS 2x4 SP No.3

BRACING
TOP CHORD Structural wood sheathing directly applied or 6-0-0 oc purlins, except end verticals. Except: 4-11-0 oc bracing: 11-16
BOT CHORD Rigid ceiling directly applied or 6-0-0 oc bracing.

REACTIONS (size) 2=10-4-0, 11=10-4-0, 12=10-4-0, 13=10-4-0, 14=10-4-0, 15=10-4-0, 17=10-4-0
Max Horiz 2=170 (LC 10), 17=170 (LC 10)
Max Uplift 2=-5 (LC 21), 11=-245 (LC 14), 13=46 (LC 14), 14=-20 (LC 10), 15=-78 (LC 14), 17=-5 (LC 21)
Max Grav 2=87 (LC 14), 11=823 (LC 21), 12=83 (LC 7), 13=190 (LC 21), 14=140 (LC 1), 15=232 (LC 21), 17=87 (LC 14)

FORCES (lb) - Maximum Compression/Maximum Tension
TOP CHORD 1-2=0/17, 2-3=-628/372, 3-4=-564/360, 4-5=-522/368, 5-6=-457/345, 6-7=-486/444, 7-9=-614/712, 9-10=-25/0, 11-16=-918/719, 7-16=-467/356
BOT CHORD 2-15=-327/314, 14-15=-327/314, 13-14=-327/314, 12-13=-327/314, 11-12=-327/314
WEBS 6-12=-115/168, 5-13=-178/183, 4-14=-103/108, 3-15=-158/181, 9-16=-772/621

NOTES

- Wind: ASCE 7-16; Vult=130mph (3-second gust) Vasd=103mph; TCDL=6.0psf; BCDL=6.0psf; h=25ft; Cat. II; Exp B; Enclosed; MWFRS (envelope) exterior zone and C-C Corner(3E) -0-10-8 to 2-4-0, Exterior(2N) 2-4-0 to 15-7-8 zone; cantilever left and right exposed; end vertical left and right exposed; C-C for members and forces & MWFRS for reactions shown; Lumber DOL=1.60 plate grip DOL=1.60
- Truss designed for wind loads in the plane of the truss only. For studs exposed to wind (normal to the face), see Standard Industry Gable End Details as applicable, or consult qualified building designer as per ANSI/TPI 1.
- TCLL: ASCE 7-16; Pr=20.0 psf (roof LL: Lum DOL=1.15 Plate DOL=1.15); Pf=20.0 psf (Lum DOL=1.15 Plate DOL=1.15); Is=1.0; Rough Cat B; Fully Exp.; Ce=0.9; Cs=1.00; Ct=1.10
- Unbalanced snow loads have been considered for this design.
- This truss has been designed for greater of min roof live load of 12.0 psf or 1.00 times flat roof load of 20.0 psf on overhangs non-concurrent with other live loads.
- All plates are 2x4 MT20 unless otherwise indicated.
- Gable requires continuous bottom chord bearing.
- Gable studs spaced at 2-0-0 oc.
- This truss has been designed for a 10.0 psf bottom chord live load nonconcurrent with any other live loads.
- * This truss has been designed for a live load of 20.0psf on the bottom chord in all areas where a rectangle 3-06-00 tall by 2-00-00 wide will fit between the bottom chord and any other members.
- Provide mechanical connection (by others) of truss to bearing plate capable of withstanding 5 lb uplift at joint 2, 245 lb uplift at joint 11, 46 lb uplift at joint 13, 20 lb uplift at joint 14, 78 lb uplift at joint 15 and 5 lb uplift at joint 2.
- Beveled plate or shim required to provide full bearing surface with truss chord at joint(s) 2, 17.

13) This truss is designed in accordance with the 2018 International Residential Code sections R502.11.1 and R802.10.2 and referenced standard ANSI/TPI 1.
LOAD CASE(S) Standard



April 14, 2023

WARNING - Verify design parameters and READ NOTES ON THIS AND INCLUDED MITEK REFERENCE PAGE MII-7473 rev. 5/19/2020 BEFORE USE.

Design valid for use only with MiTek® connectors. This design is based only upon parameters shown, and is for an individual building component, not a truss system. Before use, the building designer must verify the applicability of design parameters and properly incorporate this design into the overall building design. Bracing indicated is to prevent buckling of individual truss web and/or chord members only. Additional temporary and permanent bracing is always required for stability and to prevent collapse with possible personal injury and property damage. For general guidance regarding the fabrication, storage, delivery, erection and bracing of trusses and truss systems, see **ANSI/TPI1 Quality Criteria, DSB-89 and BCSI Building Component Safety Information** available from Truss Plate Institute, 2670 Crain Highway, Suite 203 Waldorf, MD 20601



818 Soundside Road
Edenton, NC 27932

Job 23040053-01	Truss PB1	Truss Type Piggyback	Qty 18	Ply 1	David Weekly-11 Serenity-Roof-B326 A Job Reference (optional)	I57767124
--------------------	--------------	-------------------------	-----------	----------	--	-----------

Carter Components (Sanford), Sanford, NC - 27332,

Run: 8.53 S Mar 9 2023 Print: 8.530 S Mar 9 2023 MiTek Industries, Inc. Thu Apr 13 16:17:14
ID:Cx19sF4HMnJTVINoGDnTDzRQqC-RfC?PsB70Hq3NSgPqnL8w3uITXbGKwRCDoi7J4zJC?f

Page: 1

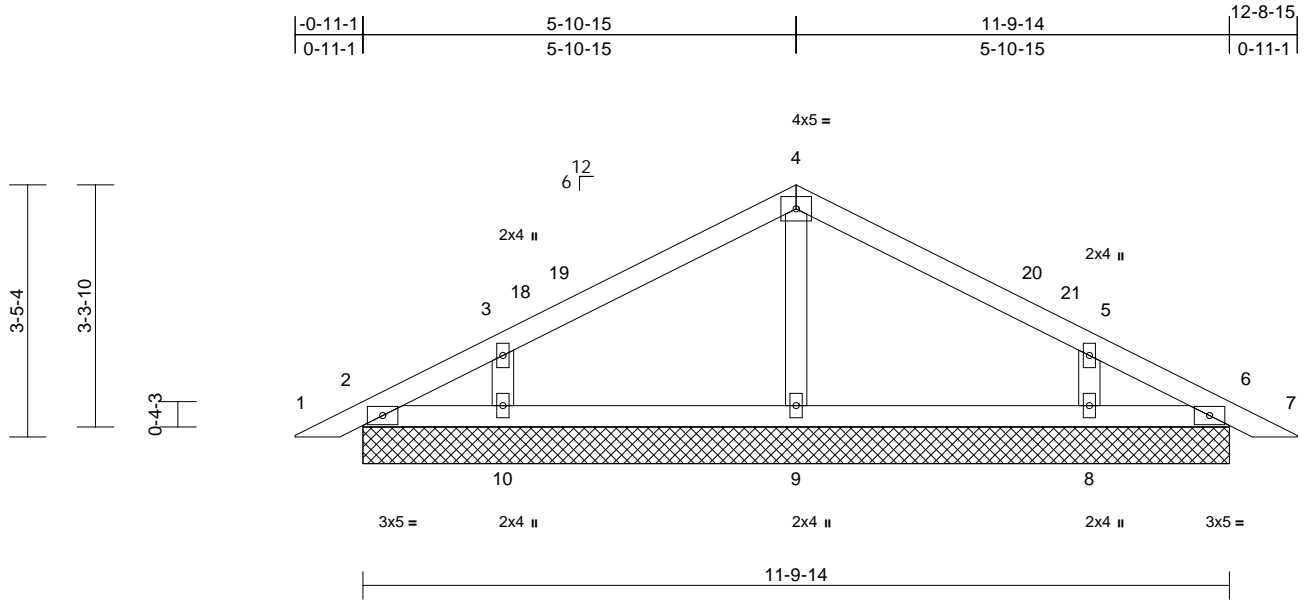

Loading	(psf)	Spacing	2-0-0	CSI	DEFL	in	(loc)	l/defl	L/d	PLATES	GRIP	
TCLL (roof)	20.0	Plate Grip DOL	1.15	TC	0.28	Vert(LL)	n/a	-	n/a	999	MT20	244/190
Snow (Pf)	20.0	Lumber DOL	1.15	BC	0.12	Vert(CT)	n/a	-	n/a	999		
TCDL	10.0	Rep Stress Incr	YES	WB	0.07	Horz(CT)	0.00	15	n/a	n/a		
BCLL	0.0*	Code	IRC2018/TPI2014	Matrix-MSH								
BCDL	10.0										Weight: 47 lb	FT = 20%

LUMBER
TOP CHORD 2x4 SP No.2
BOT CHORD 2x4 SP No.2
OTHERS 2x4 SP No.3

BRACING
TOP CHORD Structural wood sheathing directly applied or 6-0-0 oc purlins.
BOT CHORD Rigid ceiling directly applied or 10-0-0 oc bracing.

REACTIONS (size) 2=11-9-14, 6=11-9-14, 8=11-9-14, 9=11-9-14, 10=11-9-14, 11=11-9-14, 15=11-9-14
Max Horiz 2=52 (LC 18), 11=52 (LC 18)
Max Uplift 2=-11 (LC 15), 6=-4 (LC 11), 8=-87 (LC 15), 10=-87 (LC 14), 11=-11 (LC 15), 15=-4 (LC 11)
Max Grav 2=84 (LC 1), 6=84 (LC 1), 8=422 (LC 22), 9=301 (LC 21), 10=422 (LC 21), 11=84 (LC 1), 15=84 (LC 1)

FORCES (lb) - Maximum Compression/Maximum Tension
TOP CHORD 1-2=0/17, 2-3=-54/45, 3-4=-124/95, 4-5=-124/95, 5-6=-33/45, 6-7=0/17
BOT CHORD 2-10=-7/46, 9-10=-2/46, 8-9=-2/46, 6-8=-7/46
WEBS 4-9=-214/92, 3-10=-378/201, 5-8=-378/201

NOTES
1) Unbalanced roof live loads have been considered for this design.

- Wind: ASCE 7-16; Vult=130mph (3-second gust) Vasd=103mph; TCDL=6.0psf; BCDL=6.0psf; h=25ft; Cat. II; Exp B; Enclosed; MWFRS (envelope) exterior zone and C-C Exterior(2E) 0-4-3 to 3-4-3, Interior (1) 3-4-3 to 3-10-8, Exterior(2R) 3-10-8 to 9-10-8, Interior (1) 9-10-8 to 10-4-13, Exterior(2E) 10-4-13 to 13-4-13 zone; cantilever left and right exposed; end vertical left and right exposed; C-C for members and forces & MWFRS for reactions shown; Lumber DOL=1.60 plate grip DOL=1.60
- Truss designed for wind loads in the plane of the truss only. For studs exposed to wind (normal to the face), see Standard Industry Gable End Details as applicable, or consult qualified building designer as per ANSI/TPI 1.
- TCLL: ASCE 7-16; Pr=20.0 psf (roof LL: Lum DOL=1.15 Plate DOL=1.15); Pf=20.0 psf (Lum DOL=1.15 Plate DOL=1.15); Is=1.0; Rough Cat B; Fully Exp.; Ce=0.9; Cs=1.00; Ct=1.10
- Unbalanced snow loads have been considered for this design.
- This truss has been designed for greater of min roof live load of 12.0 psf or 1.00 times flat roof load of 20.0 psf on overhangs non-concurrent with other live loads.
- Gable requires continuous bottom chord bearing.
- Gable studs spaced at 4-0-0 oc.
- This truss has been designed for a 10.0 psf bottom chord live load nonconcurrent with any other live loads.
- * This truss has been designed for a live load of 20.0psf on the bottom chord in all areas where a rectangle 3-06-00 tall by 2-00-00 wide will fit between the bottom chord and any other members.
- N/A

13) See Standard Industry Piggyback Truss Connection Detail for Connection to base truss as applicable, or consult qualified building designer.
LOAD CASE(S) Standard

12) This truss is designed in accordance with the 2018 International Residential Code sections R502.11.1 and R802.10.2 and referenced standard ANSI/TPI 1.

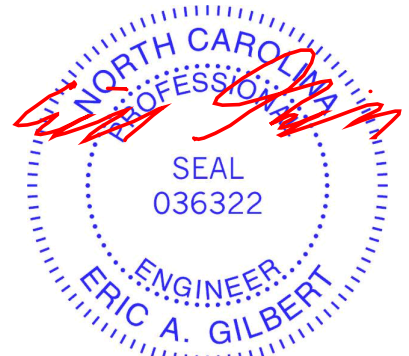

April 14, 2023

WARNING - Verify design parameters and READ NOTES ON THIS AND INCLUDED MITEK REFERENCE PAGE MII-7473 rev. 5/19/2020 BEFORE USE.

Design valid for use only with MiTek® connectors. This design is based only upon parameters shown, and is for an individual building component, not a truss system. Before use, the building designer must verify the applicability of design parameters and properly incorporate this design into the overall building design. Bracing indicated is to prevent buckling of individual truss web and/or chord members only. Additional temporary and permanent bracing is always required for stability and to prevent collapse with possible personal injury and property damage. For general guidance regarding the fabrication, storage, delivery, erection and bracing of trusses and truss systems, see **ANSI/TPI1 Quality Criteria, DSB-89 and BCSI Building Component Safety Information** available from Truss Plate Institute, 2670 Crain Highway, Suite 203 Waldorf, MD 20601



818 Soundside Road
Edenton, NC 27932

Job 23040053-01	Truss PB1GE	Truss Type Piggyback	Qty 2	Ply 1	David Weekly-11 Serenity-Roof-B326 A Job Reference (optional)	I57767125
--------------------	----------------	-------------------------	----------	----------	--	-----------

Carter Components (Sanford), Sanford, NC - 27332,

Run: 8.53 S Mar 9 2023 Print: 8.530 S Mar 9 2023 MiTek Industries, Inc. Thu Apr 13 16:17:15

Page: 1

ID:RPY8AW_GFKlcY3mFoYebvHzRQqK-RfC?PsB70Hq3NSgPqnL8w3uITXbGKWRCdoi7J4zJC?f

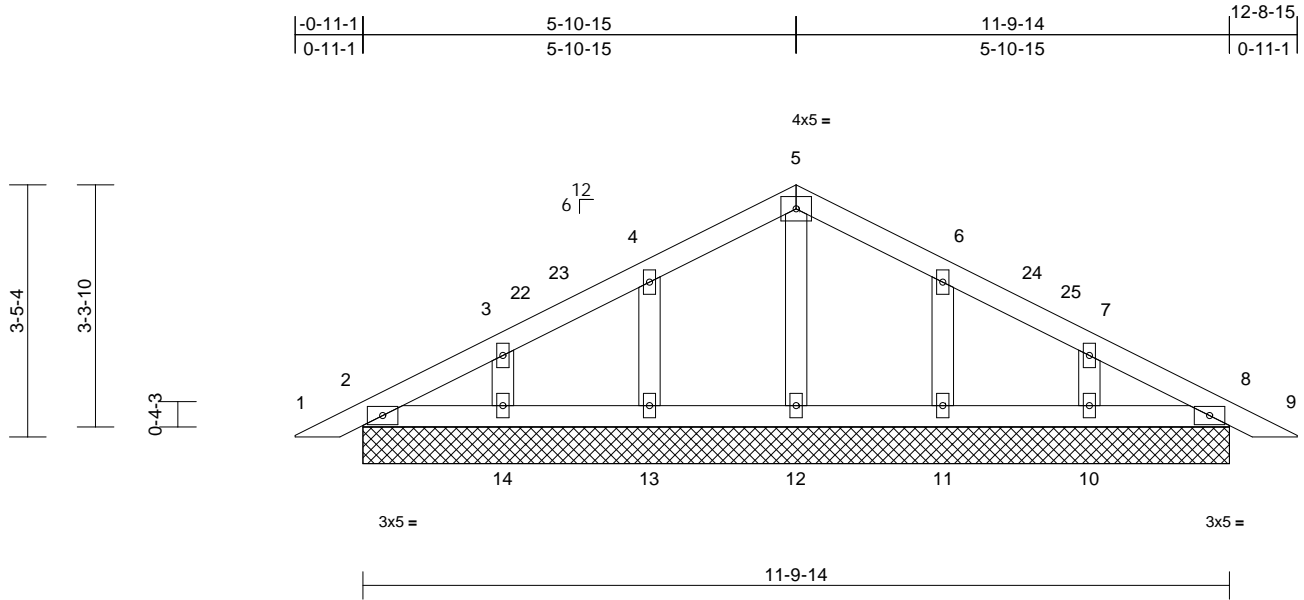

Scale = 1:31.4

Loading	(psf)	Spacing	2-0-0	CSI		DEFL	in	(loc)	l/defl	L/d	PLATES	GRIP
TCLL (roof)	20.0	Plate Grip DOL	1.15	TC	0.08	Vert(LL)	n/a	-	n/a	999	MT20	244/190
Snow (Pf)	20.0	Lumber DOL	1.15	BC	0.04	Vert(CT)	n/a	-	n/a	999		
TCDL	10.0	Rep Stress Incr	YES	WB	0.04	Horz(CT)	0.00	8	n/a	n/a		
BCLL	0.0*	Code	IRC2018/TPI2014	Matrix-MSH								
BCDL	10.0										Weight: 52 lb	FT = 20%

LUMBER
TOP CHORD 2x4 SP No.2
BOT CHORD 2x4 SP No.2
OTHERS 2x4 SP No.3

BRACING
TOP CHORD Structural wood sheathing directly applied or 6-0-0 oc purlins.
BOT CHORD Rigid ceiling directly applied or 10-0-0 oc bracing.

REACTIONS (size)
2=11-9-14, 8=11-9-14, 10=11-9-14,
11=11-9-14, 12=11-9-14,
13=11-9-14, 14=11-9-14,
15=11-9-14, 19=11-9-14
Max Horiz 2=52 (LC 18), 15=52 (LC 18)
Max Uplift 2=-9 (LC 15), 8=-11 (LC 15),
10=-45 (LC 15), 11=-47 (LC 15),
13=-47 (LC 14), 14=-45 (LC 14),
15=-9 (LC 15), 19=-11 (LC 15)
Max Grav 2=123 (LC 21), 8=123 (LC 22),
10=237 (LC 22), 11=244 (LC 22),
12=143 (LC 21), 13=244 (LC 21),
14=237 (LC 21), 15=123 (LC 21),
19=123 (LC 22)

FORCES (lb) - Maximum Compression/Maximum Tension
TOP CHORD 1-2=0/17, 2-3=-46/33, 3-4=-56/48,
4-5=-63/107, 5-6=-63/107, 6-7=-56/41,
7-8=-29/25, 8-9=0/17
BOT CHORD 2-14=-9/58, 13-14=-9/58, 12-13=-9/58,
11-12=-9/58, 10-11=-9/58, 8-10=-9/58
WEBS 5-12=-102/0, 4-13=-208/122, 3-14=-181/88,
6-11=-208/122, 7-10=-181/88

NOTES
1) Unbalanced roof live loads have been considered for this design.

- Wind: ASCE 7-16; Vult=130mph (3-second gust) Vasd=103mph; TCDL=6.0psf; BCDL=6.0psf; h=25ft; Cat. II; Exp B; Enclosed; MWFRS (envelope) exterior zone and C-C Exterior(2E) 0-4-3 to 3-4-3, Interior (1) 3-4-3 to 3-10-8, Exterior(2R) 3-10-8 to 9-10-8, Interior (1) 9-10-8 to 10-4-13, Exterior(2E) 10-4-13 to 13-4-13 zone; cantilever left and right exposed; end vertical left and right exposed; C-C for members and forces & MWFRS for reactions shown; Lumber DOL=1.60 plate grip DOL=1.60
- Truss designed for wind loads in the plane of the truss only. For studs exposed to wind (normal to the face), see Standard Industry Gable End Details as applicable, or consult qualified building designer as per ANSI/TPI 1.
- TCLL: ASCE 7-16; Pr=20.0 psf (roof LL: Lum DOL=1.15 Plate DOL=1.15); Pf=20.0 psf (Lum DOL=1.15 Plate DOL=1.15); Is=1.0; Rough Cat B; Fully Exp.; Ce=0.9; Cs=1.00; Ct=1.10
- Unbalanced snow loads have been considered for this design.
- This truss has been designed for greater of min roof live load of 12.0 psf or 1.00 times flat roof load of 20.0 psf on overhangs non-concurrent with other live loads.
- All plates are 2x4 MT20 unless otherwise indicated.
- Gable requires continuous bottom chord bearing.
- Gable studs spaced at 2-0-0 oc.
- This truss has been designed for a 10.0 psf bottom chord live load nonconcurrent with any other live loads.
- * This truss has been designed for a live load of 20.0psf on the bottom chord in all areas where a rectangle 3-06-00 tall by 2-00-00 wide will fit between the bottom chord and any other members.
- N/A

14) See Standard Industry Piggyback Truss Connection Detail for Connection to base truss as applicable, or consult qualified building designer.
LOAD CASE(S) Standard

13) This truss is designed in accordance with the 2018 International Residential Code sections R502.11.1 and R802.10.2 and referenced standard ANSI/TPI 1.

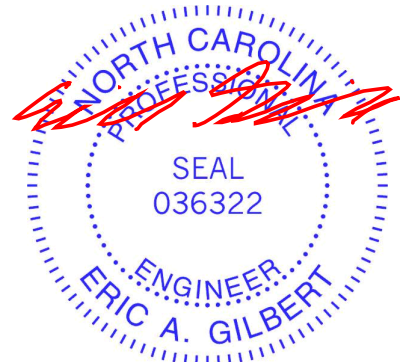

April 14, 2023

WARNING - Verify design parameters and READ NOTES ON THIS AND INCLUDED MITEK REFERENCE PAGE MII-7473 rev. 5/19/2020 BEFORE USE.

Design valid for use only with MiTek® connectors. This design is based only upon parameters shown, and is for an individual building component, not a truss system. Before use, the building designer must verify the applicability of design parameters and properly incorporate this design into the overall building design. Bracing indicated is to prevent buckling of individual truss web and/or chord members only. Additional temporary and permanent bracing is always required for stability and to prevent collapse with possible personal injury and property damage. For general guidance regarding the fabrication, storage, delivery, erection and bracing of trusses and truss systems, see **ANSI/TPI Quality Criteria, DSB-89 and BCSI Building Component Safety Information** available from Truss Plate Institute, 2670 Crain Highway, Suite 203 Waldorf, MD 20601



818 Soundside Road
Edenton, NC 27932

Job 23040053-01	Truss PB1GR	Truss Type Piggyback	Qty 2	Ply 4	David Weekly-11 Serenity-Roof-B326 A Job Reference (optional)	I57767126
--------------------	----------------	-------------------------	----------	----------	--	-----------

Carter Components (Sanford), Sanford, NC - 27332,

Run: 8.53 S Mar 9 2023 Print: 8.530 S Mar 9 2023 MiTek Industries, Inc. Thu Apr 13 16:17:16
ID:m2dQdjvppkexqPVgw5aZPzRCX1-RfC?PsB70Hq3NSgPqnL8w3uITXbGKwRCDoi7J4zJC?f

Page: 1

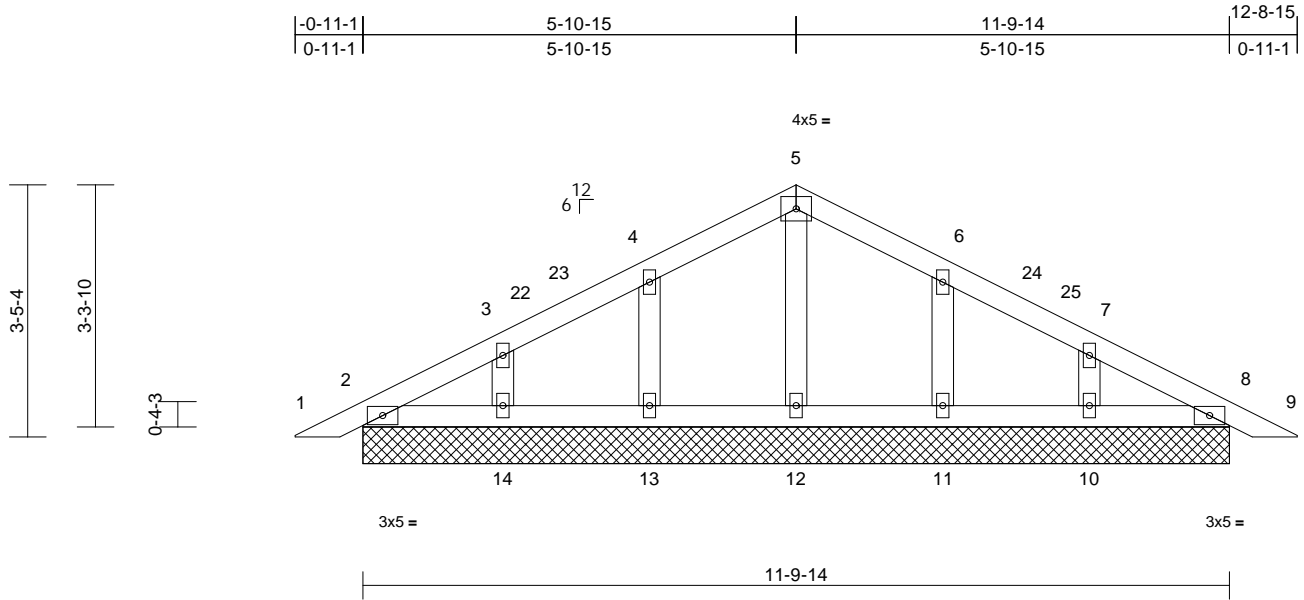

Loading	(psf)	Spacing	2-0-0	CSI	DEFL	in	(loc)	l/defl	L/d	PLATES	GRIP	
TCLL (roof)	20.0	Plate Grip DOL	1.15	TC	0.02	Vert(LL)	n/a	-	n/a	999	MT20	244/190
Snow (Pf)	20.0	Lumber DOL	1.15	BC	0.01	Vert(CT)	n/a	-	n/a	999		
TCDL	10.0	Rep Stress Incr	YES	WB	0.01	Horz(CT)	0.00	8	n/a	n/a		
BCLL	0.0*	Code	IRC2018/TPI2014	Matrix-MSH								
BCDL	10.0											
											Weight: 207 lb	FT = 20%

LUMBER

TOP CHORD 2x4 SP No.2
BOT CHORD 2x4 SP No.2
OTHERS 2x4 SP No.3

BRACING

TOP CHORD Structural wood sheathing directly applied or 6-0-0 oc purlins.
BOT CHORD Rigid ceiling directly applied or 10-0-0 oc bracing.

REACTIONS (size) 2=11-9-14, 8=11-9-14, 10=11-9-14, 11=11-9-14, 12=11-9-14, 13=11-9-14, 14=11-9-14, 15=11-9-14, 19=11-9-14

Max Horiz 2=52 (LC 18), 15=52 (LC 18)
Max Uplift 2=-9 (LC 15), 8=-12 (LC 15), 10=-45 (LC 15), 11=-47 (LC 15), 13=-47 (LC 14), 14=-45 (LC 14), 15=-9 (LC 15), 19=-12 (LC 15)
Max Grav 2=122 (LC 21), 8=122 (LC 22), 10=237 (LC 22), 11=244 (LC 22), 12=144 (LC 21), 13=244 (LC 21), 14=237 (LC 21), 15=122 (LC 21), 19=122 (LC 22)

FORCES (lb) - Maximum Compression/Maximum Tension

TOP CHORD 1-2=0/17, 2-3=-45/33, 3-4=-55/49, 4-5=-63/107, 5-6=-63/107, 6-7=-55/42, 7-8=-35/26, 8-9=0/17
BOT CHORD 2-14=-9/58, 13-14=-9/58, 12-13=-9/58, 11-12=-9/58, 10-11=-9/58, 8-10=-9/58
WEBS 5-12=-102/0, 4-13=-207/122, 3-14=-182/89, 6-11=-207/122, 7-10=-182/89

- All loads are considered equally applied to all plies, except if noted as front (F) or back (B) face in the LOAD CASE(S) section. Ply to ply connections have been provided to distribute only loads noted as (F) or (B), unless otherwise indicated.
- Unbalanced roof live loads have been considered for this design.
- Wind: ASCE 7-16; Vult=130mph (3-second gust) Vasd=103mph; TCDL=6.0psf; BCDL=6.0psf; h=25ft; Cat. II; Exp B; Enclosed; MWFRS (envelope) exterior zone and C-C Exterior(2E) 0-4-3 to 3-4-3, Interior (1) 3-4-3 to 3-10-8, Exterior(2R) 3-10-8 to 9-10-8, Interior (1) 9-10-8 to 10-4-13, Exterior(2E) 10-4-13 to 13-4-13 zone; cantilever left and right exposed; end vertical left and right exposed; C-C for members and forces & MWFRS for reactions shown; Lumber DOL=1.60 plate grip DOL=1.60
- Truss designed for wind loads in the plane of the truss only. For studs exposed to wind (normal to the face), see Standard Industry Gable End Details as applicable, or consult qualified building designer as per ANSI/TPI 1.
- TCLL: ASCE 7-16; Pr=20.0 psf (roof LL: Lum DOL=1.15 Plate DOL=1.15); Pf=20.0 psf (Lum DOL=1.15 Plate DOL=1.15); Is=1.0; Rough Cat B; Fully Exp.; Ce=0.9; Cs=1.00; Ct=1.10
- Unbalanced snow loads have been considered for this design.
- This truss has been designed for greater of min roof live load of 12.0 psf or 1.00 times flat roof load of 20.0 psf on overhangs non-concurrent with other live loads.
- All plates are 2x4 MT20 unless otherwise indicated.
- Gable requires continuous bottom chord bearing.
- Gable studs spaced at 2-0-0 oc.
- This truss has been designed for a 10.0 psf bottom chord live load nonconcurrent with any other live loads.
- * This truss has been designed for a live load of 20.0psf on the bottom chord in all areas where a rectangle 3-06-00 tall by 2-00-00 wide will fit between the bottom chord and any other members.

- N/A
 - This truss is designed in accordance with the 2018 International Residential Code sections R502.11.1 and R802.10.2 and referenced standard ANSI/TPI 1.
 - See Standard Industry Piggyback Truss Connection Detail for Connection to base truss as applicable, or consult qualified building designer.
- LOAD CASE(S)** Standard



April 14, 2023

Job 23040053-01	Truss V1	Truss Type Valley	Qty 1	Ply 1	David Weekly-11 Serenity-Roof-B326 A Job Reference (optional)	157767127
--------------------	-------------	----------------------	----------	----------	--	-----------

Carter Components (Sanford), Sanford, NC - 27332,

Run: 8.53 S Mar 9 2023 Print: 8.530 S Mar 9 2023 MiTek Industries, Inc. Thu Apr 13 16:17:17
ID:uRu6rMLa1rlmrJyJNhjxpxzRQsR-RFC?PsB70Hq3NSgPqnL8w3uITXbGKWrCDoi7J4zJC?f

Page: 1

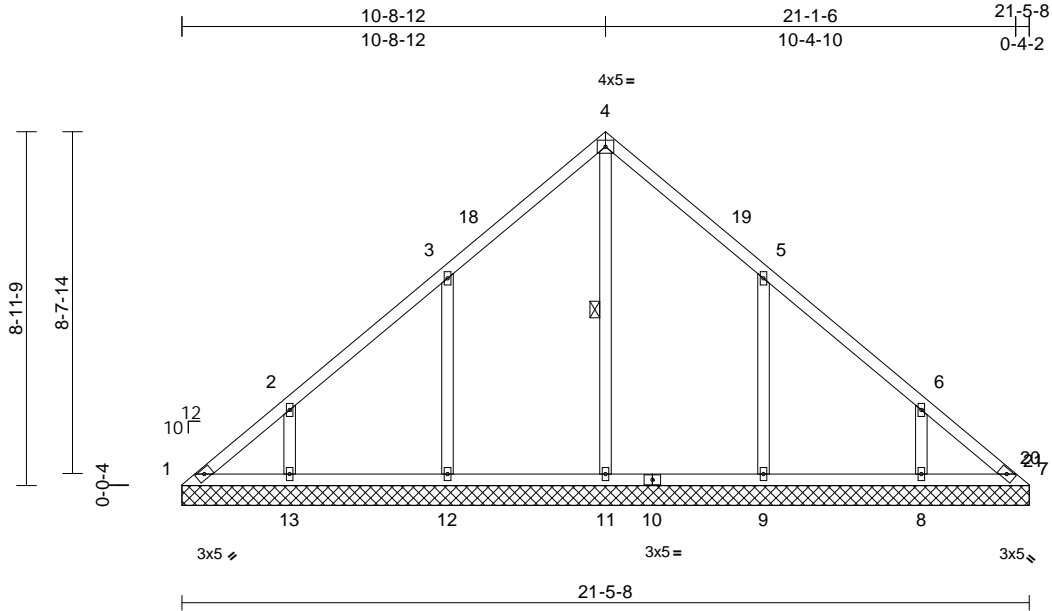

Loading	(psf)	Spacing	2-0-0	CSI	DEFL	in	(loc)	l/defl	L/d	PLATES	GRIP	
TCLL (roof)	20.0	Plate Grip DOL	1.15	TC	0.31	Vert(LL)	n/a	-	n/a	999	MT20	244/190
Snow (Pf)	20.0	Lumber DOL	1.15	BC	0.17	Vert(TL)	n/a	-	n/a	999		
TCDL	10.0	Rep Stress Incr	YES	WB	0.21	Horiz(TL)	0.01	7	n/a	n/a		
BCLL	0.0*	Code	IRC2018/TPI2014	Matrix-MSH								
BCDL	10.0											
											Weight: 105 lb	FT = 20%

LUMBER

TOP CHORD 2x4 SP No.2
BOT CHORD 2x4 SP No.2
OTHERS 2x4 SP No.3

BRACING

TOP CHORD Structural wood sheathing directly applied or 6-0-0 oc purlins.
BOT CHORD Rigid ceiling directly applied or 10-0-0 oc bracing.

WEBS 1 Row at midpt 4-11

REACTIONS (size) 1=21-5-8, 7=21-5-8, 8=21-5-8, 9=21-5-8, 11=21-5-8, 12=21-5-8, 13=21-5-8
Max Horiz 1=205 (LC 11)
Max Uplift 1=49 (LC 10), 7=7 (LC 13), 8=-112 (LC 15), 9=-174 (LC 15), 12=-173 (LC 14), 13=-118 (LC 14)
Max Grav 1=146 (LC 24), 7=107 (LC 26), 8=358 (LC 24), 9=474 (LC 6), 11=411 (LC 26), 12=474 (LC 5), 13=365 (LC 23)

FORCES (lb) - Maximum Compression/Maximum Tension
TOP CHORD 1-2=-212/172, 2-3=-166/130, 3-4=-190/180, 4-5=-190/153, 5-6=-118/80, 6-7=-168/106
BOT CHORD 1-13=-75/153, 12-13=-75/153, 11-12=-75/153, 9-11=-75/153, 8-9=-75/153, 7-8=-75/153
WEBS 4-11=-205/3, 3-12=-376/222, 2-13=-233/162, 5-9=-376/222, 6-8=-230/160

- Wind: ASCE 7-16; Vult=130mph (3-second gust) Vasd=103mph; TCDL=6.0psf; BCDL=6.0psf; h=25ft; Cat. II; Exp B; Enclosed; MWFRS (envelope) exterior zone and C-C Exterior(2E) 0-0-5 to 2-9-1, Interior (1) 2-9-1 to 7-9-1, Exterior(2R) 7-9-1 to 13-9-1, Interior (1) 13-9-1 to 18-1-4, Exterior(2E) 18-1-4 to 21-1-4 zone; cantilever left and right exposed ; end vertical left and right exposed;C-C for members and forces & MWFRS for reactions shown; Lumber DOL=1.60 plate grip DOL=1.60
- Truss designed for wind loads in the plane of the truss only. For studs exposed to wind (normal to the face), see Standard Industry Gable End Details as applicable, or consult qualified building designer as per ANSI/TPI 1.
- TCLL: ASCE 7-16; Pr=20.0 psf (roof LL: Lum DOL=1.15 Plate DOL=1.15); Pf=20.0 psf (Lum DOL=1.15 Plate DOL=1.15); Is=1.0; Rough Cat B; Fully Exp.; Ce=0.9; Cs=1.00; Ct=1.10
- Unbalanced snow loads have been considered for this design.
- All plates are 2x4 MT20 unless otherwise indicated.
- Gable requires continuous bottom chord bearing.
- Gable studs spaced at 4-0-0 oc.
- This truss has been designed for a 10.0 psf bottom chord live load nonconcurrent with any other live loads.
- * This truss has been designed for a live load of 20.0psf on the bottom chord in all areas where a rectangle 3-06-00 tall by 2-00-00 wide will fit between the bottom chord and any other members, with BCDL = 10.0psf.
- Provide mechanical connection (by others) of truss to bearing plate capable of withstanding 49 lb uplift at joint 1, 7 lb uplift at joint 7, 173 lb uplift at joint 12, 118 lb uplift at joint 13, 174 lb uplift at joint 9 and 112 lb uplift at joint 8.
- This truss is designed in accordance with the 2018 International Residential Code sections R502.11.1 and R802.10.2 and referenced standard ANSI/TPI 1.

LOAD CASE(S) Standard



April 14, 2023

WARNING - Verify design parameters and READ NOTES ON THIS AND INCLUDED MITEK REFERENCE PAGE MII-7473 rev. 5/19/2020 BEFORE USE.

Design valid for use only with MiTek® connectors. This design is based only upon parameters shown, and is for an individual building component, not a truss system. Before use, the building designer must verify the applicability of design parameters and properly incorporate this design into the overall building design. Bracing indicated is to prevent buckling of individual truss web and/or chord members only. Additional temporary and permanent bracing is always required for stability and to prevent collapse with possible personal injury and property damage. For general guidance regarding the fabrication, storage, delivery, erection and bracing of trusses and truss systems, see **ANSI/TPI1 Quality Criteria, DSB-89 and BCSI Building Component Safety Information** available from Truss Plate Institute, 2670 Crain Highway, Suite 203 Waldorf, MD 20601



818 Soundside Road
Edenton, NC 27932

Job 23040053-01	Truss V2	Truss Type Valley	Qty 1	Ply 1	David Weekly-11 Serenity-Roof-B326 A Job Reference (optional)	157767128
--------------------	-------------	----------------------	----------	----------	--	-----------

Carter Components (Sanford), Sanford, NC - 27332,

Run: 8.53 S Mar 9 2023 Print: 8.530 S Mar 9 2023 MiTek Industries, Inc. Thu Apr 13 16:17:18
ID:yJln_UX?VSB9dbBmLUS1zzRQsC-RfC?PsB70Hq3NSgPqnL8w3uTXbGKWrCDoi7J4zJC?r

Page: 1

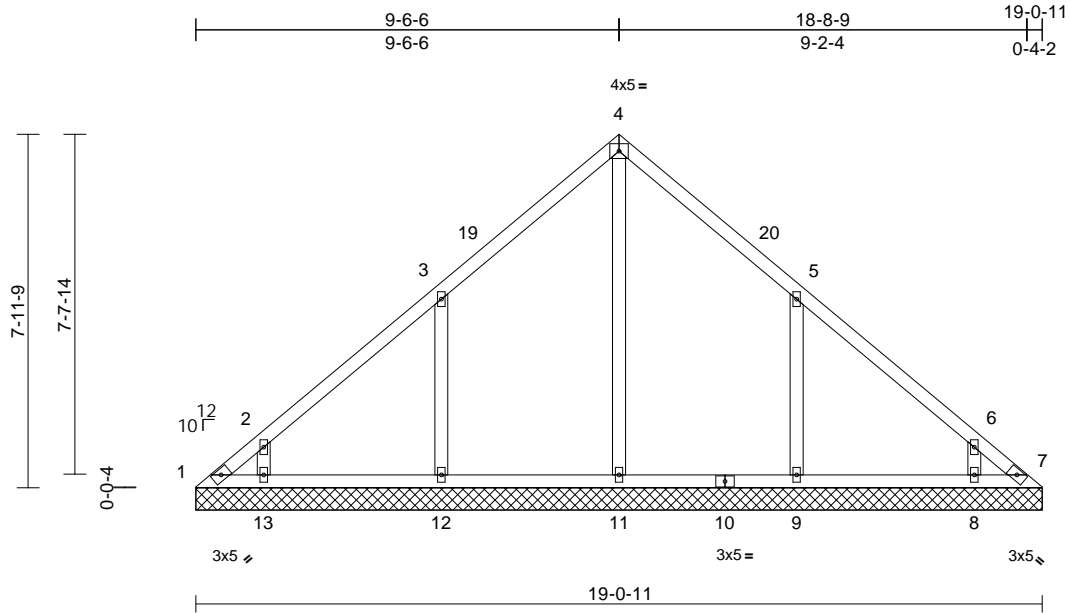

Scale = 1:51.9

Loading	(psf)	Spacing	2-0-0	CSI	DEFL	in	(loc)	l/defl	L/d	PLATES	GRIP
TCLL (roof)	20.0	Plate Grip DOL	1.15	TC	0.31	Vert(LL)	n/a	-	999	MT20	244/190
Snow (Pf)	20.0	Lumber DOL	1.15	BC	0.17	Vert(TL)	n/a	-	999		
TCDL	10.0	Rep Stress Incr	YES	WB	0.27	Horiz(TL)	0.00	7	n/a		
BCLL	0.0*	Code	IRC2018/TPI2014	Matrix-MSH							
BCDL	10.0									Weight: 89 lb	FT = 20%

LUMBER
TOP CHORD 2x4 SP No.2
BOT CHORD 2x4 SP No.2
OTHERS 2x4 SP No.3

BRACING
TOP CHORD Structural wood sheathing directly applied or 6-0-0 oc purlins.
BOT CHORD Rigid ceiling directly applied or 10-0-0 oc bracing.

REACTIONS (size)
1=19-0-11, 7=19-0-11, 8=19-0-11, 9=19-0-11, 11=19-0-11, 12=19-0-11, 13=19-0-11, 18=19-0-11
Max Horiz 1=182 (LC 11)
Max Uplift 1=-96 (LC 12), 8=-48 (LC 15), 9=-194 (LC 15), 12=-174 (LC 14), 13=-101 (LC 14)
Max Grav 1=122 (LC 11), 7=0 (LC 13), 8=298 (LC 24), 9=478 (LC 24), 11=450 (LC 26), 12=480 (LC 5), 13=318 (LC 23), 18=0 (LC 13)

FORCES (lb) - Maximum Compression/Maximum Tension
TOP CHORD 1-2=-219/200, 2-3=-223/182, 3-4=-195/261, 4-5=-183/235, 5-6=-115/61, 6-7=-79/40
BOT CHORD 1-13=-46/66, 12-13=-16/61, 11-12=-16/61, 9-11=-16/61, 8-9=-16/61, 7-8=-16/61
WEBS 4-11=-243/61, 3-12=-379/221, 2-13=-225/177, 5-9=-377/229, 6-8=-218/157

NOTES
1) Unbalanced roof live loads have been considered for this design.

- Wind: ASCE 7-16; Vult=130mph (3-second gust) Vasd=103mph; TCDL=6.0psf; BCDL=6.0psf; h=25ft; Cat. II; Exp B; Enclosed; MWFRS (envelope) exterior zone and C-C Exterior(2E) 0-0-5 to 3-0-5, Interior (1) 3-0-5 to 6-6-10, Exterior(2R) 6-6-10 to 12-6-10, Interior (1) 12-6-10 to 15-8-7, Exterior(2E) 15-8-7 to 18-8-7 zone; cantilever left and right exposed; end vertical left and right exposed; C-C for members and forces & MWFRS for reactions shown; Lumber DOL=1.60 plate grip DOL=1.60
- Truss designed for wind loads in the plane of the truss only. For studs exposed to wind (normal to the face), see Standard Industry Gable End Details as applicable, or consult qualified building designer as per ANSI/TPI 1.
- TCLL: ASCE 7-16; Pr=20.0 psf (roof LL: Lum DOL=1.15 Plate DOL=1.15); Pf=20.0 psf (Lum DOL=1.15 Plate DOL=1.15); Is=1.0; Rough Cat B; Fully Exp.; Ce=0.9; Cs=1.00; Ct=1.10
- Unbalanced snow loads have been considered for this design.
- All plates are 2x4 MT20 unless otherwise indicated.
- Gable requires continuous bottom chord bearing.
- Gable studs spaced at 4-0-0 oc.
- This truss has been designed for a 10.0 psf bottom chord live load nonconcurrent with any other live loads.
- * This truss has been designed for a live load of 20.0psf on the bottom chord in all areas where a rectangle 3-06-00 tall by 2-00-00 wide will fit between the bottom chord and any other members, with BCDL = 10.0psf.
- Provide mechanical connection (by others) of truss to bearing plate capable of withstanding 96 lb uplift at joint 1, 174 lb uplift at joint 12, 101 lb uplift at joint 13, 194 lb uplift at joint 9 and 48 lb uplift at joint 8.
- This truss is designed in accordance with the 2018 International Residential Code sections R502.11.1 and R802.10.2 and referenced standard ANSI/TPI 1.

LOAD CASE(S) Standard

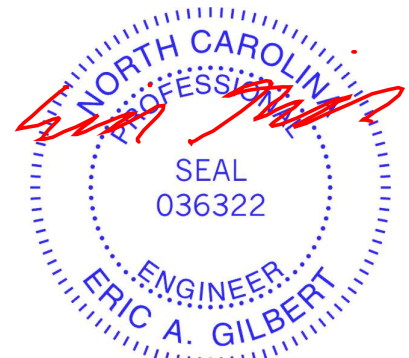

April 14, 2023

WARNING - Verify design parameters and READ NOTES ON THIS AND INCLUDED MITEK REFERENCE PAGE MII-7473 rev. 5/19/2020 BEFORE USE.

Design valid for use only with MiTek® connectors. This design is based only upon parameters shown, and is for an individual building component, not a truss system. Before use, the building designer must verify the applicability of design parameters and properly incorporate this design into the overall building design. Bracing indicated is to prevent buckling of individual truss web and/or chord members only. Additional temporary and permanent bracing is always required for stability and to prevent collapse with possible personal injury and property damage. For general guidance regarding the fabrication, storage, delivery, erection and bracing of trusses and truss systems, see ANSITPI1 Quality Criteria, DSB-89 and BCSI Building Component Safety Information available from Truss Plate Institute, 2670 Crain Highway, Suite 203 Waldorf, MD 20601

ENGINEERING BY
TRENCO
A MiTek Affiliate

818 Soundside Road
Edenton, NC 27932

Job 23040053-01	Truss V3	Truss Type Valley	Qty 1	Ply 1	David Weekly-11 Serenity-Roof-B326 A Job Reference (optional)	157767129
--------------------	-------------	----------------------	----------	----------	--	-----------

Carter Components (Sanford), Sanford, NC - 27332,

Run: 8.53 S Mar 9 2023 Print: 8.530 S Mar 9 2023 MiTek Industries, Inc. Thu Apr 13 16:17:19
ID:4pahjxh9RSqoCd5h0aDV3jzRQs?-RfC?PsB70Hq3NSgPqnL8w3uITXbGKWrCDoi7J4zJC7f

Page: 1

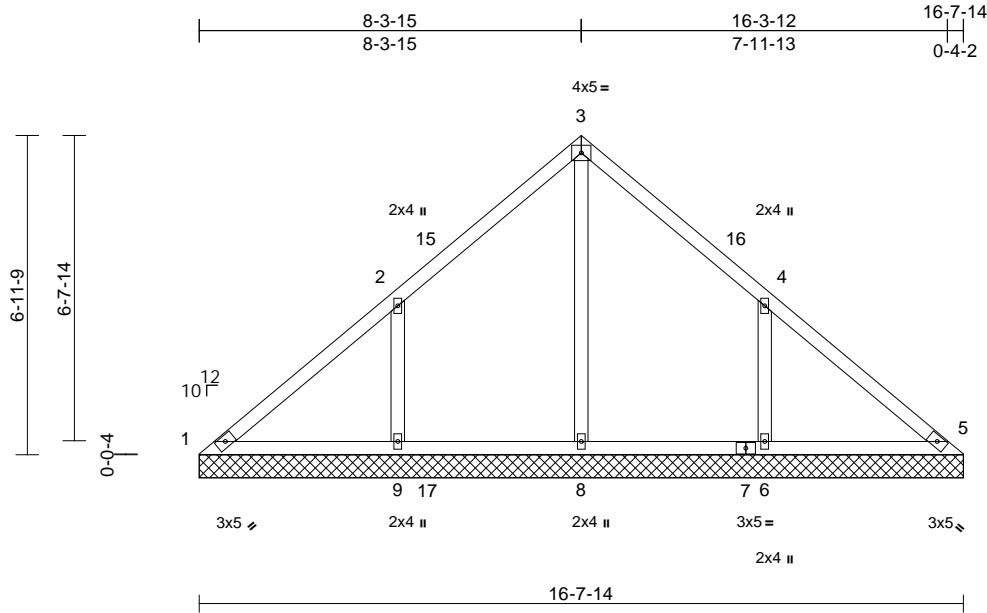

Loading	(psf)	Spacing	2-0-0	CSI	DEFL	in	(loc)	l/defl	L/d	PLATES	GRIP	
TCLL (roof)	20.0	Plate Grip DOL	1.15	TC	0.38	Vert(LL)	n/a	-	n/a	999	MT20	244/190
Snow (Pf)	20.0	Lumber DOL	1.15	BC	0.17	Vert(TL)	n/a	-	n/a	999		
TCDL	10.0	Rep Stress Incr	YES	WB	0.39	Horiz(TL)	0.00	5	n/a	n/a		
BCLL	0.0*	Code	IRC2018/TPI2014	Matrix-MSH								
BCDL	10.0											
											Weight: 74 lb	FT = 20%

LUMBER
TOP CHORD 2x4 SP No.2
BOT CHORD 2x4 SP No.2
OTHERS 2x4 SP No.3

BRACING
TOP CHORD Structural wood sheathing directly applied or 10-0-0 oc purlins.
BOT CHORD Rigid ceiling directly applied or 6-0-0 oc bracing.

REACTIONS (size) 1=16-7-14, 5=16-7-14, 6=16-7-14, 8=16-7-14, 9=16-7-14, 14=16-7-14
Max Horiz 1=159 (LC 11)
Max Uplift 1=-58 (LC 10), 6=-181 (LC 15), 9=-186 (LC 14)
Max Grav 1=81 (LC 33), 5=1 (LC 24), 6=507 (LC 6), 8=649 (LC 23), 9=505 (LC 5), 14=1 (LC 24)

FORCES (lb) - Maximum Compression/Maximum Tension
TOP CHORD 1-2=-105/363, 2-3=-28/314, 3-4=-4/293, 4-5=-132/283
BOT CHORD 1-9=-175/74, 8-9=-175/72, 6-8=-175/72, 5-6=-175/72
WEBS 3-8=-464/0, 2-9=-390/218, 4-6=-390/217

- Truss designed for wind loads in the plane of the truss only. For studs exposed to wind (normal to the face), see Standard Industry Gable End Details as applicable, or consult qualified building designer as per ANSI/TPI 1.
- TCLL: ASCE 7-16; Pr=20.0 psf (roof LL: Lum DOL=1.15 Plate DOL=1.15); Pf=20.0 psf (Lum DOL=1.15 Plate DOL=1.15); Is=1.0; Rough Cat B; Fully Exp.; Ce=0.9; Cs=1.00; Ct=1.10
- Unbalanced snow loads have been considered for this design.
- Gable requires continuous bottom chord bearing.
- Gable studs spaced at 4-0-0 oc.
- This truss has been designed for a 10.0 psf bottom chord live load nonconcurrent with any other live loads.
- * This truss has been designed for a live load of 20.0psf on the bottom chord in all areas where a rectangle 3-06-00 tall by 2-00-00 wide will fit between the bottom chord and any other members, with BCDL = 10.0psf.
- Provide mechanical connection (by others) of truss to bearing plate capable of withstanding 58 lb uplift at joint 1, 186 lb uplift at joint 9 and 181 lb uplift at joint 6.
- This truss is designed in accordance with the 2018 International Residential Code sections R502.11.1 and R802.10.2 and referenced standard ANSI/TPI 1.

LOAD CASE(S) Standard

- NOTES**
- Unbalanced roof live loads have been considered for this design.
 - Wind: ASCE 7-16; Vult=130mph (3-second gust) Vasd=103mph; TCDL=6.0psf; BCDL=6.0psf; h=25ft; Cat. II; Exp B; Enclosed; MWFRS (envelope) exterior zone and C-C Exterior(2E) 0-0-5 to 3-0-5, Interior (1) 3-0-5 to 5-4-4, Exterior(2R) 5-4-4 to 11-4-4, Interior (1) 11-4-4 to 13-3-11, Exterior(2E) 13-3-11 to 16-3-11 zone; cantilever left and right exposed ; end vertical left and right exposed;C-C for members and forces & MWFRS for reactions shown; Lumber DOL=1.60 plate grip DOL=1.60

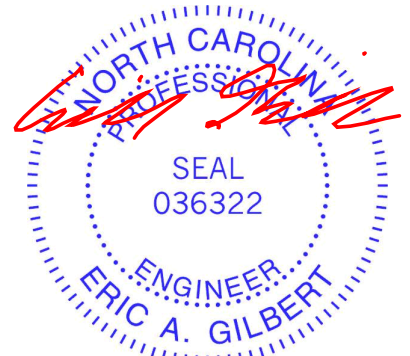

April 14, 2023

WARNING - Verify design parameters and READ NOTES ON THIS AND INCLUDED MITEK REFERENCE PAGE MII-7473 rev. 5/19/2020 BEFORE USE.

Design valid for use only with MiTek® connectors. This design is based only upon parameters shown, and is for an individual building component, not a truss system. Before use, the building designer must verify the applicability of design parameters and properly incorporate this design into the overall building design. Bracing indicated is to prevent buckling of individual truss web and/or chord members only. Additional temporary and permanent bracing is always required for stability and to prevent collapse with possible personal injury and property damage. For general guidance regarding the fabrication, storage, delivery, erection and bracing of trusses and truss systems, see ANSITPI1 Quality Criteria, DSB-89 and BCSI Building Component Safety Information available from Truss Plate Institute, 2670 Crain Highway, Suite 203 Waldorf, MD 20601

ENGINEERING BY
TRENCO
A MiTek Affiliate

818 Soundside Road
Edenton, NC 27932

Job 23040053-01	Truss V4	Truss Type Valley	Qty 1	Ply 1	David Weekly-11 Serenity-Roof-B326 A Job Reference (optional)	157767130
--------------------	-------------	----------------------	----------	----------	--	-----------

Carter Components (Sanford), Sanford, NC - 27332,

Run: 8.53 S Mar 9 2023 Print: 8.530 S Mar 9 2023 MiTek Industries, Inc. Thu Apr 13 16:17:20

Page: 1

ID:CKtcSNrNSSyGdaBHoyY5SzRQro-RFC?PsB70Hq3NSgPqnL8w3uITXbGKWRCDoi7J4zJC?f

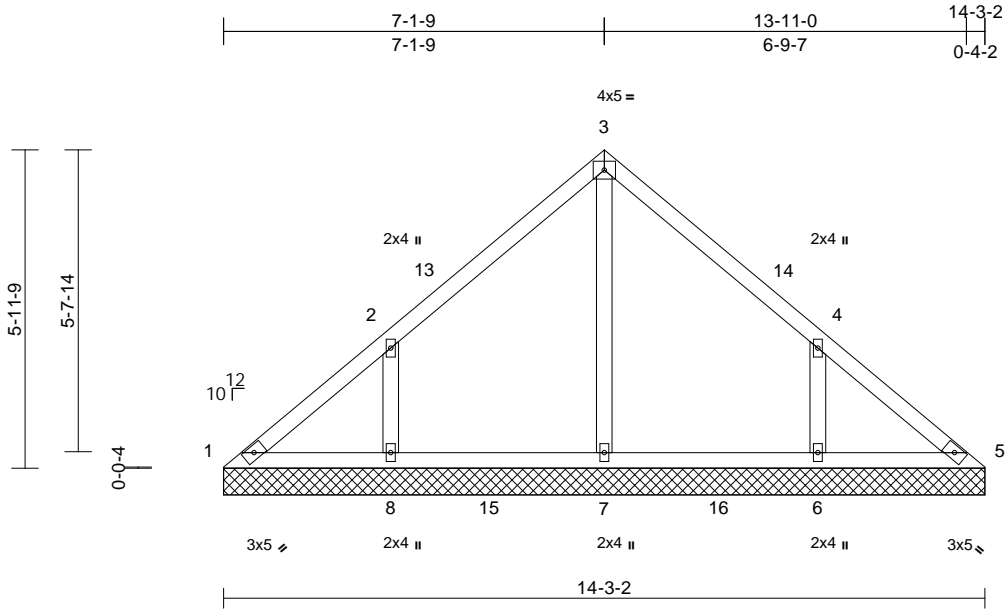

Loading	(psf)	Spacing	2-0-0	CSI	DEFL	in	(loc)	l/defl	L/d	PLATES	GRIP	
TCLL (roof)	20.0	Plate Grip DOL	1.15	TC	0.34	Vert(LL)	n/a	-	n/a	999	MT20	244/190
Snow (Pf)	20.0	Lumber DOL	1.15	BC	0.16	Vert(TL)	n/a	-	n/a	999		
TCDL	10.0	Rep Stress Incr	YES	WB	0.14	Horiz(TL)	0.00	5	n/a	n/a		
BCLL	0.0*	Code	IRC2018/TPI2014	Matrix-MSH								
BCDL	10.0											
											Weight: 62 lb	FT = 20%

LUMBER
TOP CHORD 2x4 SP No.2
BOT CHORD 2x4 SP No.2
OTHERS 2x4 SP No.3

BRACING
TOP CHORD Structural wood sheathing directly applied or 6-0-0 oc purlins.
BOT CHORD Rigid ceiling directly applied or 6-0-0 oc bracing.

REACTIONS (size) 1=14-3-2, 5=14-3-2, 6=14-3-2, 7=14-3-2, 8=14-3-2
Max Horiz 1=-136 (LC 10)
Max Uplift 1=-24 (LC 10), 6=-153 (LC 15), 8=-156 (LC 14)
Max Grav 1=122 (LC 24), 5=98 (LC 23), 6=452 (LC 21), 7=397 (LC 23), 8=452 (LC 20)

FORCES (lb) - Maximum Compression/Maximum Tension
TOP CHORD 1-2=-151/135, 2-3=-180/118, 3-4=-180/112, 4-5=-121/100
BOT CHORD 1-8=-57/124, 7-8=-57/98, 6-7=-57/98, 5-6=-57/98
WEBS 3-7=-219/0, 2-8=-374/195, 4-6=-374/194

- Truss designed for wind loads in the plane of the truss only. For studs exposed to wind (normal to the face), see Standard Industry Gable End Details as applicable, or consult qualified building designer as per ANSI/TPI 1.
- TCLL: ASCE 7-16; Pr=20.0 psf (roof LL: Lum DOL=1.15 Plate DOL=1.15); Pf=20.0 psf (Lum DOL=1.15 Plate DOL=1.15); Is=1.0; Rough Cat B; Fully Exp.; Ce=0.9; Cs=1.00; Ct=1.10
- Unbalanced snow loads have been considered for this design.
- Gable requires continuous bottom chord bearing.
- Gable studs spaced at 4-0-0 oc.
- This truss has been designed for a 10.0 psf bottom chord live load nonconcurrent with any other live loads.
- * This truss has been designed for a live load of 20.0psf on the bottom chord in all areas where a rectangle 3-06-00 tall by 2-00-00 wide will fit between the bottom chord and any other members, with BCDL = 10.0psf.
- Provide mechanical connection (by others) of truss to bearing plate capable of withstanding 24 lb uplift at joint 1, 156 lb uplift at joint 8 and 153 lb uplift at joint 6.
- This truss is designed in accordance with the 2018 International Residential Code sections R502.11.1 and R802.10.2 and referenced standard ANSI/TPI 1.

LOAD CASE(S) Standard

- NOTES**
- Unbalanced roof live loads have been considered for this design.
 - Wind: ASCE 7-16; Vult=130mph (3-second gust) Vasd=103mph; TCDL=6.0psf; BCDL=6.0psf; h=25ft; Cat. II; Exp B; Enclosed; MWFRS (envelope) exterior zone and C-C Exterior(2E) 0-0-5 to 3-1-14, Interior (1) 3-1-14 to 4-1-14, Exterior(2R) 4-1-14 to 10-1-14, Interior (1) 10-1-14 to 11-1-14, Exterior(2E) 11-1-14 to 14-3-6 zone; cantilever left and right exposed; end vertical left and right exposed; C-C for members and forces & MWFRS for reactions shown; Lumber DOL=1.60 plate grip DOL=1.60

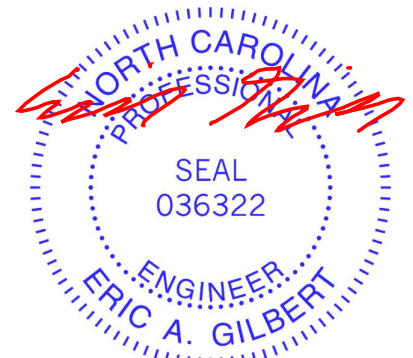

April 14, 2023

WARNING - Verify design parameters and READ NOTES ON THIS AND INCLUDED MITEK REFERENCE PAGE MII-7473 rev. 5/19/2020 BEFORE USE.

Design valid for use only with MiTek® connectors. This design is based only upon parameters shown, and is for an individual building component, not a truss system. Before use, the building designer must verify the applicability of design parameters and properly incorporate this design into the overall building design. Bracing indicated is to prevent buckling of individual truss web and/or chord members only. Additional temporary and permanent bracing is always required for stability and to prevent collapse with possible personal injury and property damage. For general guidance regarding the fabrication, storage, delivery, erection and bracing of trusses and truss systems, see **ANSI/TPI1 Quality Criteria, DSB-89 and BCSI Building Component Safety Information** available from Truss Plate Institute, 2670 Crain Highway, Suite 203 Waldorf, MD 20601



818 Soundside Road
Edenton, NC 27932

Job 23040053-01	Truss V5	Truss Type Valley	Qty 1	Ply 1	David Weekly-11 Serenity-Roof-B326 A Job Reference (optional)	157767131
--------------------	-------------	----------------------	----------	----------	--	-----------

Carter Components (Sanford), Sanford, NC - 27332,

Run: 8.53 S Mar 9 2023 Print: 8.530 S Mar 9 2023 MiTek Industries, Inc. Thu Apr 13 16:17:20
ID:vFTOYozalWjXT9L6tv8uVZzRQre-RfC?PsB70Hq3NSgPqnL8w3uITXbGKWrCDoi7J4zJC?f

Page: 1

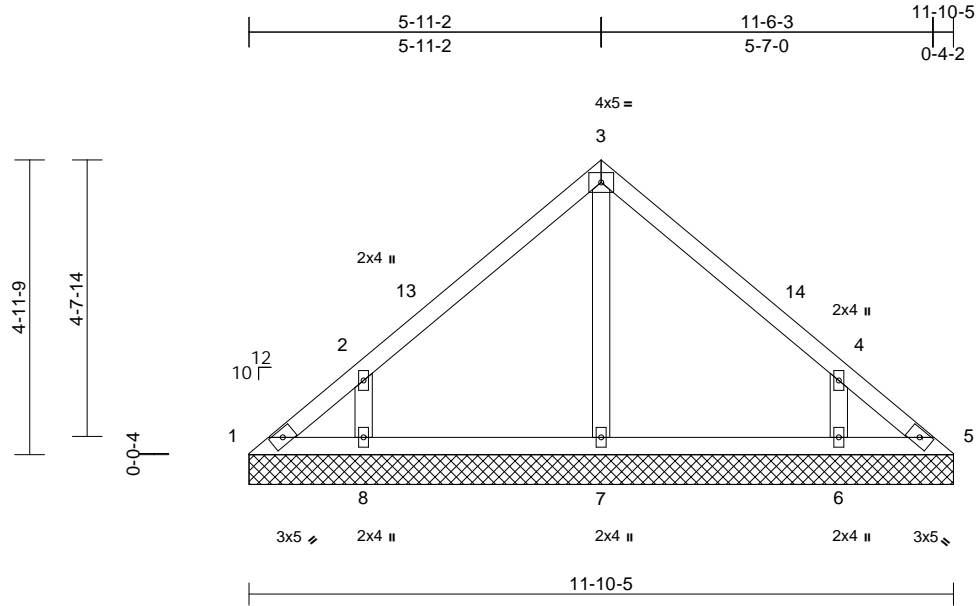

Scale = 1:38.8

Loading	(psf)	Spacing	2-0-0	CSI	DEFL	in	(loc)	l/defl	L/d	PLATES	GRIP	
TCLL (roof)	20.0	Plate Grip DOL	1.15	TC	0.31	Vert(LL)	n/a	-	n/a	999	MT20	244/190
Snow (Pf)	20.0	Lumber DOL	1.15	BC	0.12	Vert(TL)	n/a	-	n/a	999		
TCDL	10.0	Rep Stress Incr	YES	WB	0.08	Horiz(TL)	0.00	5	n/a	n/a		
BCLL	0.0*	Code	IRC2018/TPI2014	Matrix-MSH								
BCDL	10.0											
										Weight: 49 lb	FT = 20%	

LUMBER

TOP CHORD 2x4 SP No.2
BOT CHORD 2x4 SP No.2
OTHERS 2x4 SP No.3

BRACING

TOP CHORD Structural wood sheathing directly applied or 6-0-0 oc purlins.
BOT CHORD Rigid ceiling directly applied or 10-0-0 oc bracing.

REACTIONS

(size) 1=11-10-5, 5=11-10-5, 6=11-10-5, 7=11-10-5, 8=11-10-5
Max Horiz 1=112 (LC 13)
Max Uplift 1=-35 (LC 10), 5=-7 (LC 11), 6=-135 (LC 15), 8=-139 (LC 14)
Max Grav 1=88 (LC 24), 5=67 (LC 23), 6=435 (LC 21), 7=257 (LC 20), 8=435 (LC 20)

FORCES

(lb) - Maximum Compression/Maximum Tension
TOP CHORD 1-2=-115/100, 2-3=-220/115, 3-4=-220/115, 4-5=-90/63
BOT CHORD 1-8=-32/73, 7-8=-29/73, 6-7=-29/73, 5-6=-29/73
WEBS 3-7=-170/0, 2-8=-407/225, 4-6=-407/225

NOTES

- 1) Unbalanced roof live loads have been considered for this design.
- 2) Wind: ASCE 7-16; Vult=130mph (3-second gust) Vasd=103mph; TCDL=6.0psf; BCDL=6.0psf; h=25ft; Cat. II; Exp B; Enclosed; MWFRS (envelope) exterior zone and C-C Exterior(2E) 0-0-5 to 3-0-5, Exterior(2R) 3-0-5 to 8-10-10, Exterior(2E) 8-10-10 to 11-10-10 zone; cantilever left and right exposed; end vertical left and right exposed; C-C for members and forces & MWFRS for reactions shown; Lumber DOL=1.60 plate grip DOL=1.60

- 3) Truss designed for wind loads in the plane of the truss only. For studs exposed to wind (normal to the face), see Standard Industry Gable End Details as applicable, or consult qualified building designer as per ANSI/TPI 1.
- 4) TCLL: ASCE 7-16; Pr=20.0 psf (roof LL: Lum DOL=1.15 Plate DOL=1.15); Pf=20.0 psf (Lum DOL=1.15 Plate DOL=1.15); Is=1.0; Rough Cat B; Fully Exp.; Ce=0.9; Cs=1.00; Ct=1.10
- 5) Unbalanced snow loads have been considered for this design.
- 6) Gable requires continuous bottom chord bearing.
- 7) Gable studs spaced at 4-0-0 oc.
- 8) This truss has been designed for a 10.0 psf bottom chord live load nonconcurrent with any other live loads.
- 9) * This truss has been designed for a live load of 20.0psf on the bottom chord in all areas where a rectangle 3-06-00 tall by 2-00-00 wide will fit between the bottom chord and any other members.
- 10) Provide mechanical connection (by others) of truss to bearing plate capable of withstanding 35 lb uplift at joint 1, 7 lb uplift at joint 5, 139 lb uplift at joint 8 and 135 lb uplift at joint 6.
- 11) This truss is designed in accordance with the 2018 International Residential Code sections R502.11.1 and R802.10.2 and referenced standard ANSI/TPI 1.

LOAD CASE(S) Standard

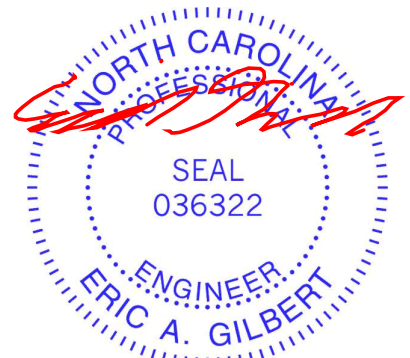

April 14, 2023

WARNING - Verify design parameters and READ NOTES ON THIS AND INCLUDED MITEK REFERENCE PAGE MII-7473 rev. 5/19/2020 BEFORE USE.

Design valid for use only with MiTek® connectors. This design is based only upon parameters shown, and is for an individual building component, not a truss system. Before use, the building designer must verify the applicability of design parameters and properly incorporate this design into the overall building design. Bracing indicated is to prevent buckling of individual truss web and/or chord members only. Additional temporary and permanent bracing is always required for stability and to prevent collapse with possible personal injury and property damage. For general guidance regarding the fabrication, storage, delivery, erection and bracing of trusses and truss systems, see ANSITPI1 Quality Criteria, DSB-89 and BCSI Building Component Safety Information available from Truss Plate Institute, 2670 Crain Highway, Suite 203 Waldorf, MD 20601



818 Soundside Road
Edenton, NC 27932

Job 23040053-01	Truss V6	Truss Type Valley	Qty 1	Ply 1	David Weekly-11 Serenity-Roof-B326 A Job Reference (optional)	157767132
--------------------	-------------	----------------------	----------	----------	--	-----------

Carter Components (Sanford), Sanford, NC - 27332,

Run: 8.53 S Mar 9 2023 Print: 8.530 S Mar 9 2023 MiTek Industries, Inc. Thu Apr 13 16:17:21
ID:vFTOYozalWjXT9L6tv8uVZzRQre-RfC?PsB70Hq3NSgPqnl8w3uITxBGKWrCDoi7J4zJC?f

Page: 1

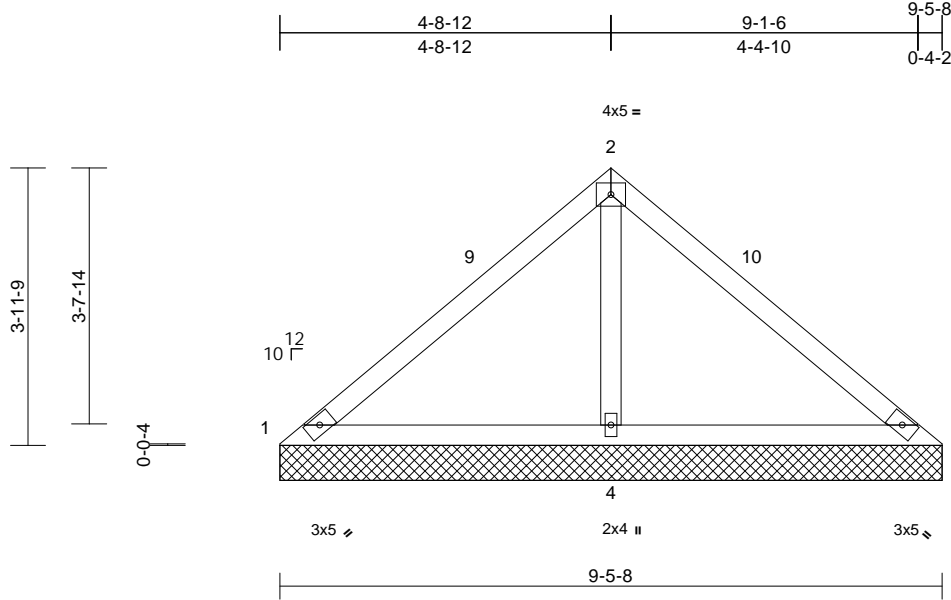

Scale = 1:32.9

Loading	(psf)	Spacing	2-0-0	CSI	DEFL	in	(loc)	l/defl	L/d	PLATES	GRIP	
TCLL (roof)	20.0	Plate Grip DOL	1.15	TC	0.43	Vert(LL)	n/a	-	n/a	999	MT20	244/190
Snow (Pf)	20.0	Lumber DOL	1.15	BC	0.41	Vert(TL)	n/a	-	n/a	999		
TCDL	10.0	Rep Stress Incr	YES	WB	0.17	Horiz(TL)	0.00	4	n/a	n/a		
BCLL	0.0*	Code	IRC2018/TPI2014	Matrix-MSH								
BCDL	10.0										Weight: 36 lb	FT = 20%

LUMBER

TOP CHORD	2x4 SP No.2
BOT CHORD	2x4 SP No.2
OTHERS	2x4 SP No.3

BRACING

TOP CHORD	Structural wood sheathing directly applied or 9-5-8 oc purlins.
BOT CHORD	Rigid ceiling directly applied or 6-0-0 oc bracing.

REACTIONS

(size)	1=9-5-8, 3=9-5-8, 4=9-5-8
Max Horiz	1=-89 (LC 10)
Max Uplift	1=-45 (LC 21), 3=-45 (LC 20), 4=-105 (LC 14)
Max Grav	1=96 (LC 20), 3=96 (LC 21), 4=751 (LC 21)

FORCES

(lb) - Maximum Compression/Maximum Tension	
TOP CHORD	1-2=-111/360, 2-3=-111/360
BOT CHORD	1-4=-207/169, 3-4=-207/169
WEBS	2-4=-577/265

NOTES

- Unbalanced roof live loads have been considered for this design.
- Wind: ASCE 7-16; Vult=130mph (3-second gust) Vasd=103mph; TCDL=6.0psf; BCDL=6.0psf; h=25ft; Cat. II; Exp B; Enclosed; MWFRS (envelope) exterior zone and C-C Exterior(2E) 0-0-5 to 3-0-5, Exterior(2R) 3-0-5 to 6-5-13, Exterior(2E) 6-5-13 to 9-5-13 zone; cantilever left and right exposed ; end vertical left and right exposed;C-C for members and forces & MWFRS for reactions shown; Lumber DOL=1.60 plate grip DOL=1.60
- Truss designed for wind loads in the plane of the truss only. For studs exposed to wind (normal to the face), see Standard Industry Gable End Details as applicable, or consult qualified building designer as per ANSI/TPI 1.

- TCLL: ASCE 7-16; Pr=20.0 psf (roof LL: Lum DOL=1.15 Plate DOL=1.15); Pf=20.0 psf (Lum DOL=1.15 Plate DOL=1.15); Is=1.0; Rough Cat B; Fully Exp.; Ce=0.9; Cs=1.00; Ct=1.10
- Unbalanced snow loads have been considered for this design.
- Gable requires continuous bottom chord bearing.
- Gable studs spaced at 4-0-0 oc.
- This truss has been designed for a 10.0 psf bottom chord live load nonconcurrent with any other live loads.
- * This truss has been designed for a live load of 20.0psf on the bottom chord in all areas where a rectangle 3-06-00 tall by 2-00-00 wide will fit between the bottom chord and any other members.
- Provide mechanical connection (by others) of truss to bearing plate capable of withstanding 45 lb uplift at joint 1, 45 lb uplift at joint 3 and 105 lb uplift at joint 4.
- This truss is designed in accordance with the 2018 International Residential Code sections R502.11.1 and R802.10.2 and referenced standard ANSI/TPI 1.

LOAD CASE(S) Standard



April 14, 2023

WARNING - Verify design parameters and READ NOTES ON THIS AND INCLUDED MITEK REFERENCE PAGE MII-7473 rev. 5/19/2020 BEFORE USE.

Design valid for use only with MiTek® connectors. This design is based only upon parameters shown, and is for an individual building component, not a truss system. Before use, the building designer must verify the applicability of design parameters and properly incorporate this design into the overall building design. Bracing indicated is to prevent buckling of individual truss web and/or chord members only. Additional temporary and permanent bracing is always required for stability and to prevent collapse with possible personal injury and property damage. For general guidance regarding the fabrication, storage, delivery, erection and bracing of trusses and truss systems, see ANSI/TPI1 Quality Criteria, DSB-89 and BCSI Building Component Safety Information available from Truss Plate Institute, 2670 Crain Highway, Suite 203 Waldorf, MD 20601



818 Soundside Road
Edenton, NC 27932

Job 23040053-01	Truss V7	Truss Type Valley	Qty 1	Ply 1	David Weekly-11 Serenity-Roof-B326 A Job Reference (optional)	157767133
--------------------	-------------	----------------------	----------	----------	--	-----------

Carter Components (Sanford), Sanford, NC - 27332,

Run: 8.53 S Mar 9 2023 Print: 8.530 S Mar 9 2023 MiTek Industries, Inc. Thu Apr 13 16:17:21
ID:vFTOYoza1WjXT9L6tv8uVZrQre-RfC?PsB70Hq3NSgPqnL8w3uITxBGKWrCDoi7J4zJC?f

Page: 1

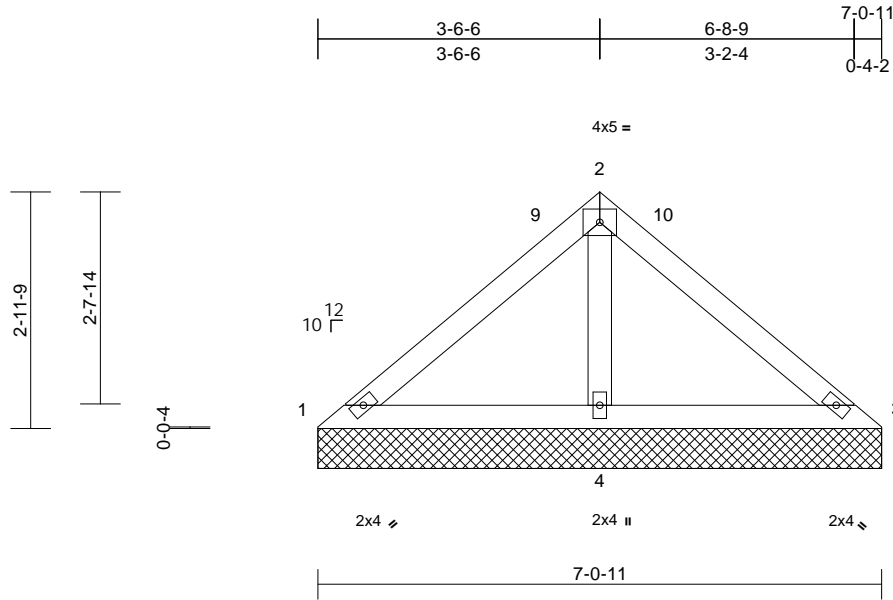

Loading	(psf)	Spacing	2-0-0	CSI	DEFL	in	(loc)	l/defl	L/d	PLATES	GRIP	
TCLL (roof)	20.0	Plate Grip DOL	1.15	TC	0.24	Vert(LL)	n/a	-	n/a	999	MT20	244/190
Snow (Pf)	20.0	Lumber DOL	1.15	BC	0.25	Vert(TL)	n/a	-	n/a	999		
TCDL	10.0	Rep Stress Incr	YES	WB	0.08	Horiz(TL)	0.00	4	n/a	n/a		
BCLL	0.0*	Code	IRC2018/TPI2014	Matrix-MP								
BCDL	10.0											
											Weight: 26 lb	FT = 20%

LUMBER
TOP CHORD 2x4 SP No.2
BOT CHORD 2x4 SP No.2
OTHERS 2x4 SP No.3

BRACING
TOP CHORD Structural wood sheathing directly applied or 7-0-11 oc purlins.
BOT CHORD Rigid ceiling directly applied or 6-0-0 oc bracing.

REACTIONS (size) 1=7-0-11, 3=7-0-11, 4=7-0-11
Max Horiz 1=65 (LC 11)
Max Uplift 1=-14 (LC 21), 3=-14 (LC 20), 4=-70 (LC 14)
Max Grav 1=104 (LC 20), 3=104 (LC 21), 4=512 (LC 21)

FORCES (lb) - Maximum Compression/Maximum Tension
TOP CHORD 1-2=-86/218, 2-3=-86/218
BOT CHORD 1-4=-154/147, 3-4=-154/147
WEBS 2-4=-362/192

- TCLL: ASCE 7-16; Pr=20.0 psf (roof LL: Lum DOL=1.15 Plate DOL=1.15); Pf=20.0 psf (Lum DOL=1.15 Plate DOL=1.15); Is=1.0; Rough Cat B; Fully Exp.; Ce=0.9; Cs=1.00; Ct=1.10
- Unbalanced snow loads have been considered for this design.
- Gable requires continuous bottom chord bearing.
- Gable studs spaced at 4-0-0 oc.
- This truss has been designed for a 10.0 psf bottom chord live load nonconcurrent with any other live loads.
- * This truss has been designed for a live load of 20.0psf on the bottom chord in all areas where a rectangle 3-06-00 tall by 2-00-00 wide will fit between the bottom chord and any other members.
- Provide mechanical connection (by others) of truss to bearing plate capable of withstanding 14 lb uplift at joint 1, 14 lb uplift at joint 3 and 70 lb uplift at joint 4.
- This truss is designed in accordance with the 2018 International Residential Code sections R502.11.1 and R802.10.2 and referenced standard ANSI/TPI 1.

LOAD CASE(S) Standard

- NOTES**
- Unbalanced roof live loads have been considered for this design.
 - Wind: ASCE 7-16; Vult=130mph (3-second gust) Vasd=103mph; TCDL=6.0psf; BCDL=6.0psf; h=25ft; Cat. II; Exp B; Enclosed; MWFRS (envelope) exterior zone and C-C Exterior(2E) 0-0-5 to 3-0-5, Exterior(2R) 3-0-5 to 4-1-0, Exterior(2E) 4-1-0 to 7-1-0 zone; cantilever left and right exposed; end vertical left and right exposed; C-C for members and forces & MWFRS for reactions shown; Lumber DOL=1.60 plate grip DOL=1.60
 - Truss designed for wind loads in the plane of the truss only. For studs exposed to wind (normal to the face), see Standard Industry Gable End Details as applicable, or consult qualified building designer as per ANSI/TPI 1.

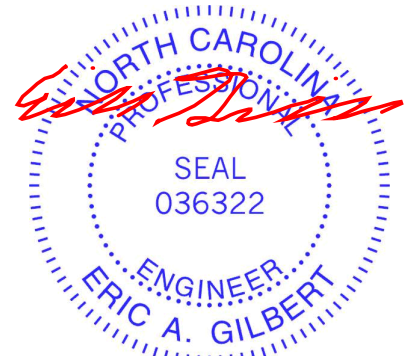

April 14, 2023

WARNING - Verify design parameters and READ NOTES ON THIS AND INCLUDED MITEK REFERENCE PAGE MII-7473 rev. 5/19/2020 BEFORE USE.

Design valid for use only with MiTek® connectors. This design is based only upon parameters shown, and is for an individual building component, not a truss system. Before use, the building designer must verify the applicability of design parameters and properly incorporate this design into the overall building design. Bracing indicated is to prevent buckling of individual truss web and/or chord members only. Additional temporary and permanent bracing is always required for stability and to prevent collapse with possible personal injury and property damage. For general guidance regarding the fabrication, storage, delivery, erection and bracing of trusses and truss systems, see

ANSI/TPI1 Quality Criteria, DSB-89 and BCSI Building Component

Safety Information available from Truss Plate Institute, 2670 Crain Highway, Suite 203 Waldorf, MD 20601



818 Soundside Road
Edenton, NC 27932

Job 23040053-01	Truss V8	Truss Type Valley	Qty 1	Ply 1	David Weekly-11 Serenity-Roof-B326 A Job Reference (optional)	157767134
--------------------	-------------	----------------------	----------	----------	--	-----------

Carter Components (Sanford), Sanford, NC - 27332,

Run: 8.53 S Mar 9 2023 Print: 8.530 S Mar 9 2023 MiTek Industries, Inc. Thu Apr 13 16:17:22
ID:vFTOY0za1WjXT9L6tv8uVZzRQre-RfC?PsB70Hq3NSgPqnL8w3uITxbGKWrCDoi7J4zJC?f

Page: 1

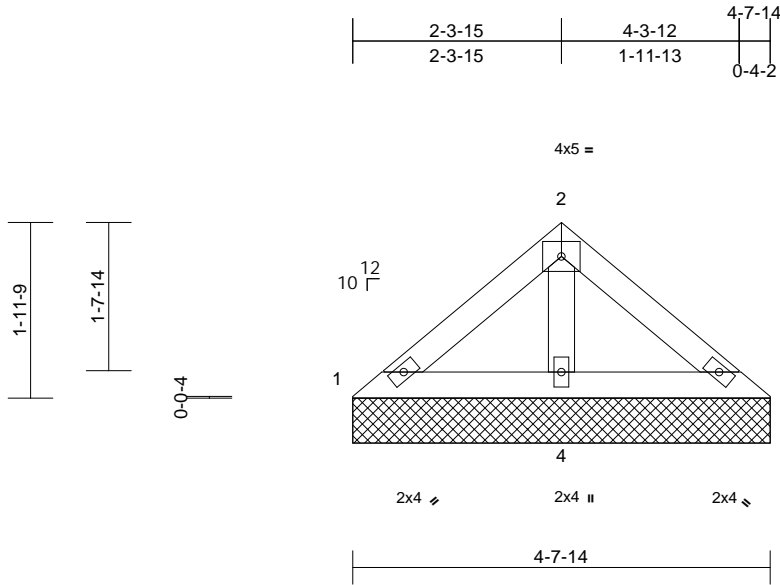

Loading	(psf)	Spacing	2-0-0	CSI	DEFL	in	(loc)	l/defl	L/d	PLATES	GRIP	
TCLL (roof)	20.0	Plate Grip DOL	1.15	TC	0.08	Vert(LL)	n/a	-	n/a	999	MT20	244/190
Snow (Pf)	20.0	Lumber DOL	1.15	BC	0.10	Vert(TL)	n/a	-	n/a	999		
TCDL	10.0	Rep Stress Incr	YES	WB	0.03	Horiz(TL)	0.00	4	n/a	n/a		
BCLL	0.0*	Code	IRC2018/TPI2014	Matrix-MP								
BCDL	10.0											
										Weight: 17 lb	FT = 20%	

LUMBER
TOP CHORD 2x4 SP No.2
BOT CHORD 2x4 SP No.2
OTHERS 2x4 SP No.3

BRACING
TOP CHORD Structural wood sheathing directly applied or 4-7-14 oc purlins.
BOT CHORD Rigid ceiling directly applied or 6-0-0 oc bracing.

REACTIONS (size) 1=4-7-14, 3=4-7-14, 4=4-7-14
Max Horiz 1=42 (LC 11)
Max Uplift 3=-7 (LC 15), 4=-31 (LC 14)
Max Grav 1=86 (LC 20), 3=86 (LC 21), 4=279 (LC 21)

FORCES (lb) - Maximum Compression/Maximum Tension
TOP CHORD 1-2=-79/95, 2-3=-79/95
BOT CHORD 1-4=-74/82, 3-4=-74/82
WEBS 2-4=-169/88

- Unbalanced snow loads have been considered for this design.
- Gable requires continuous bottom chord bearing.
- Gable studs spaced at 4-0-0 oc.
- This truss has been designed for a 10.0 psf bottom chord live load nonconcurrent with any other live loads.
- * This truss has been designed for a live load of 20.0psf on the bottom chord in all areas where a rectangle 3-06-00 tall by 2-00-00 wide will fit between the bottom chord and any other members.
- Provide mechanical connection (by others) of truss to bearing plate capable of withstanding 7 lb uplift at joint 3 and 31 lb uplift at joint 4.
- This truss is designed in accordance with the 2018 International Residential Code sections R502.11.1 and R802.10.2 and referenced standard ANSI/TPI 1.

LOAD CASE(S) Standard

- NOTES**
- Unbalanced roof live loads have been considered for this design.
 - Wind: ASCE 7-16; Vult=130mph (3-second gust) Vasd=103mph; TCDL=6.0psf; BCDL=6.0psf; h=25ft; Cat. II; Exp B; Enclosed; MWFRS (envelope) exterior zone and C-C Exterior(2E) zone; cantilever left and right exposed; end vertical left and right exposed; C-C for members and forces & MWFRS for reactions shown; Lumber DOL=1.60 plate grip DOL=1.60
 - Truss designed for wind loads in the plane of the truss only. For studs exposed to wind (normal to the face), see Standard Industry Gable End Details as applicable, or consult qualified building designer as per ANSI/TPI 1.
 - TCLL: ASCE 7-16; Pr=20.0 psf (roof LL: Lum DOL=1.15 Plate DOL=1.15); Pf=20.0 psf (Lum DOL=1.15 Plate DOL=1.15); Is=1.0; Rough Cat B; Fully Exp.; Ce=0.9; Cs=1.00; Ct=1.10

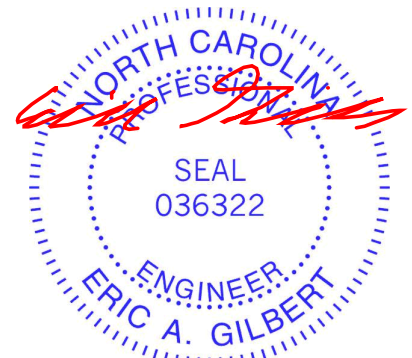

April 14, 2023

WARNING - Verify design parameters and READ NOTES ON THIS AND INCLUDED MITEK REFERENCE PAGE MII-7473 rev. 5/19/2020 BEFORE USE.

Design valid for use only with MiTek® connectors. This design is based only upon parameters shown, and is for an individual building component, not a truss system. Before use, the building designer must verify the applicability of design parameters and properly incorporate this design into the overall building design. Bracing indicated is to prevent buckling of individual truss web and/or chord members only. Additional temporary and permanent bracing is always required for stability and to prevent collapse with possible personal injury and property damage. For general guidance regarding the fabrication, storage, delivery, erection and bracing of trusses and truss systems, see

ANSI/TPI1 Quality Criteria, DSB-89 and BCSI Building Component

Safety Information available from Truss Plate Institute, 2670 Crain Highway, Suite 203 Waldorf, MD 20601



818 Soundside Road
Edenton, NC 27932

Job 23040053-01	Truss V11	Truss Type Valley	Qty 1	Ply 1	David Weekly-11 Serenity-Roof-B326 A Job Reference (optional)	157767135
--------------------	--------------	----------------------	----------	----------	--	-----------

Carter Components (Sanford), Sanford, NC - 27332,

Run: 8.53 S Mar 9 2023 Print: 8.530 S Mar 9 2023 MiTek Industries, Inc. Thu Apr 13 16:17:23
ID:?VRASUfm0qfd3oFPBHC5FHzRQud-RfC?PsB70Hq3NSgPqnL8w3uITXbGkWrCDoi7J4zJC?f

Page: 1

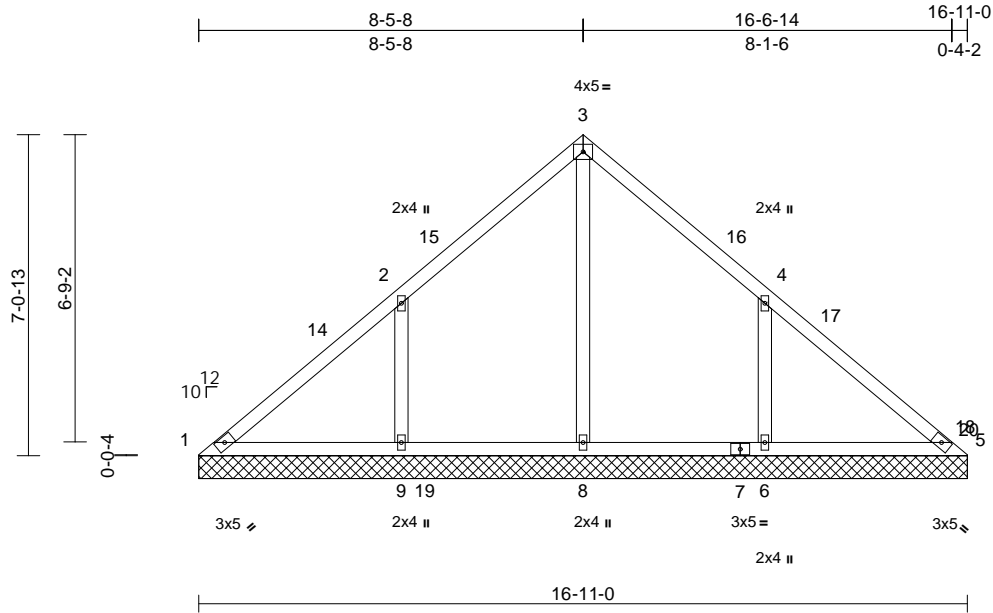

Scale = 1:50.7

Loading	(psf)	Spacing	2-0-0	CSI	DEFL	in	(loc)	l/defl	L/d	PLATES	GRIP	
TCLL (roof)	20.0	Plate Grip DOL	1.15	TC	0.35	Vert(LL)	n/a	-	n/a	999	MT20	244/190
Snow (Pf)	20.0	Lumber DOL	1.15	BC	0.18	Vert(TL)	n/a	-	n/a	999		
TCDL	10.0	Rep Stress Incr	YES	WB	0.27	Horiz(TL)	0.00	5	n/a	n/a		
BCLL	0.0*	Code	IRC2018/TPI2014	Matrix-MSH								
BCDL	10.0											
										Weight: 76 lb	FT = 20%	

LUMBER	
TOP CHORD	2x4 SP No.2
BOT CHORD	2x4 SP No.2
OTHERS	2x4 SP No.3
BRACING	
TOP CHORD	Structural wood sheathing directly applied or 6-0-0 oc purlins.
BOT CHORD	Rigid ceiling directly applied or 6-0-0 oc bracing.
REACTIONS (size)	
	1=16-11-0, 5=16-11-0, 6=16-11-0, 8=16-11-0, 9=16-11-0
Max Horiz	1=161 (LC 11)
Max Uplift	1=-21 (LC 10), 6=-183 (LC 15), 9=-186 (LC 14)
Max Grav	1=123 (LC 28), 5=86 (LC 21), 6=520 (LC 6), 8=495 (LC 23), 9=524 (LC 23)
FORCES (lb) - Maximum Compression/Maximum Tension	
TOP CHORD	1-2=-146/252, 2-3=-109/188, 3-4=-110/168, 4-5=-111/210
BOT CHORD	1-9=-117/132, 8-9=-117/130, 6-8=-117/130, 5-6=-117/130
WEBS	3-8=-310/0, 2-9=-396/220, 4-6=-396/219

- NOTES**
- 1) Unbalanced roof live loads have been considered for this design.
 - 2) Wind: ASCE 7-16; Vult=130mph (3-second gust) Vasd=103mph; TCDL=6.0psf; BCDL=6.0psf; h=25ft; Cat. II; Exp B; Enclosed; MWFRS (envelope) exterior zone and C-C Exterior(2E) 0-0-5 to 3-0-5, Interior (1) 3-0-5 to 5-5-13, Exterior(2R) 5-5-13 to 11-5-13, Interior (1) 11-5-13 to 13-6-12, Exterior(2E) 13-6-12 to 16-6-12 zone; cantilever left and right exposed; end vertical left and right exposed; C-C for members and forces & MWFRS for reactions shown; Lumber DOL=1.60 plate grip DOL=1.60

- 3) Truss designed for wind loads in the plane of the truss only. For studs exposed to wind (normal to the face), see Standard Industry Gable End Details as applicable, or consult qualified building designer as per ANSI/TPI 1.
- 4) TCLL: ASCE 7-16; Pr=20.0 psf (roof LL: Lum DOL=1.15 Plate DOL=1.15); Pf=20.0 psf (Lum DOL=1.15 Plate DOL=1.15); Is=1.0; Rough Cat B; Fully Exp.; Ce=0.9; Cs=1.00; Ct=1.10
- 5) Unbalanced snow loads have been considered for this design.
- 6) Gable requires continuous bottom chord bearing.
- 7) Gable studs spaced at 4-0-0 oc.
- 8) This truss has been designed for a 10.0 psf bottom chord live load nonconcurrent with any other live loads.
- 9) * This truss has been designed for a live load of 20.0psf on the bottom chord in all areas where a rectangle 3-06-00 tall by 2-00-00 wide will fit between the bottom chord and any other members, with BCDL = 10.0psf.
- 10) Provide mechanical connection (by others) of truss to bearing plate capable of withstanding 21 lb uplift at joint 1, 186 lb uplift at joint 9 and 183 lb uplift at joint 6.
- 11) This truss is designed in accordance with the 2018 International Residential Code sections R502.11.1 and R802.10.2 and referenced standard ANSI/TPI 1.

LOAD CASE(S) Standard



April 14, 2023

WARNING - Verify design parameters and READ NOTES ON THIS AND INCLUDED MITEK REFERENCE PAGE MII-7473 rev. 5/19/2020 BEFORE USE.

Design valid for use only with MiTek® connectors. This design is based only upon parameters shown, and is for an individual building component, not a truss system. Before use, the building designer must verify the applicability of design parameters and properly incorporate this design into the overall building design. Bracing indicated is to prevent buckling of individual truss web and/or chord members only. Additional temporary and permanent bracing is always required for stability and to prevent collapse with possible personal injury and property damage. For general guidance regarding the fabrication, storage, delivery, erection and bracing of trusses and truss systems, see **ANSI/TPI1 Quality Criteria, DSB-89 and BCSI Building Component Safety Information** available from Truss Plate Institute, 2670 Crain Highway, Suite 203 Waldorf, MD 20601



818 Soundside Road
Edenton, NC 27932

Job 23040053-01	Truss V12	Truss Type Valley	Qty 1	Ply 1	David Weekly-11 Serenity-Roof-B326 A Job Reference (optional)	157767136
--------------------	--------------	----------------------	----------	----------	--	-----------

Carter Components (Sanford), Sanford, NC - 27332,

Run: 8.53 S Mar 9 2023 Print: 8.530 S Mar 9 2023 MiTek Industries, Inc. Thu Apr 13 16:17:23
ID:Th_ZgqfOm8nUgyqbk?jKoVzRQuC-RfC?PsB70Hq3NSgPqnL8w3uITXbGkWrCDoi7J4zJC?F

Page: 1

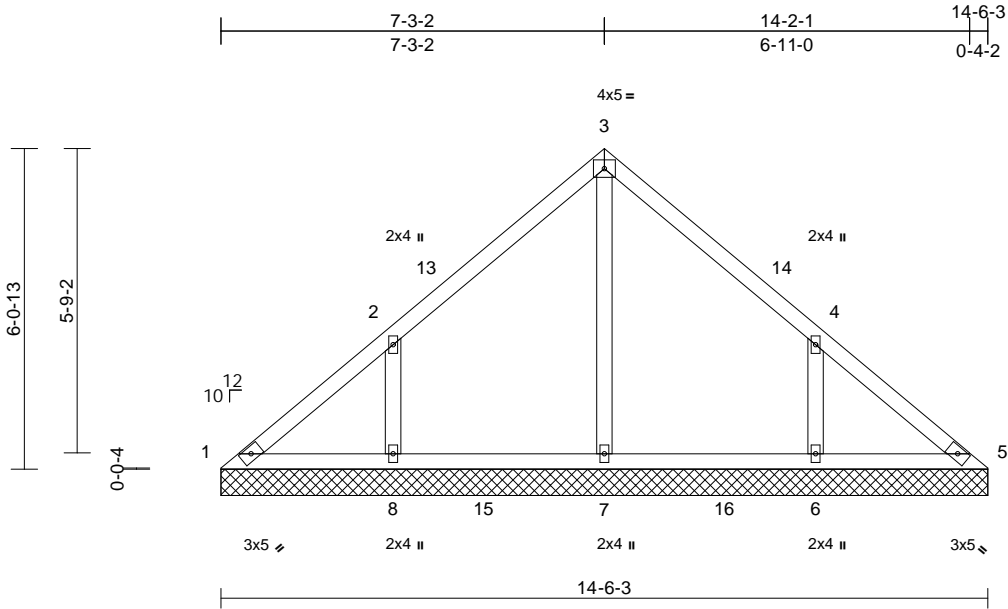

Scale = 1:43.6					
Loading (psf)	Spacing 2-0-0	CSI	DEFL in (loc) l/defl L/d	PLATES	GRIP
TCLL (roof) 20.0	Plate Grip DOL 1.15	TC 0.31	Vert(LL) n/a - n/a 999	MT20	244/190
Snow (Pf) 20.0	Lumber DOL 1.15	BC 0.16	Vert(TL) n/a - n/a 999		
TCDL 10.0	Rep Stress Incr YES	WB 0.14	Horiz(TL) 0.00 5 n/a n/a		
BCLL 0.0*	Code IRC2018/TPI2014	Matrix-MSH			
BCDL 10.0				Weight: 63 lb	FT = 20%

LUMBER
TOP CHORD 2x4 SP No.2
BOT CHORD 2x4 SP No.2
OTHERS 2x4 SP No.3

BRACING
TOP CHORD Structural wood sheathing directly applied or 6-0-0 oc purlins.
BOT CHORD Rigid ceiling directly applied or 6-0-0 oc bracing.

REACTIONS (size) 1=14-6-3, 5=14-6-3, 6=14-6-3, 7=14-6-3, 8=14-6-3
Max Horiz 1=138 (LC 13)
Max Uplift 1=-24 (LC 10), 6=-155 (LC 15), 8=-158 (LC 14)
Max Grav 1=124 (LC 24), 5=99 (LC 23), 6=456 (LC 21), 7=406 (LC 23), 8=456 (LC 20)

FORCES (lb) - Maximum Compression/Maximum Tension
TOP CHORD 1-2=-153/144, 2-3=-174/120, 3-4=-174/111, 4-5=-121/109
BOT CHORD 1-8=-61/127, 7-8=-61/101, 6-7=-61/101, 5-6=-61/101
WEBS 3-7=-226/0, 2-8=-375/197, 4-6=-375/195

- Truss designed for wind loads in the plane of the truss only. For studs exposed to wind (normal to the face), see Standard Industry Gable End Details as applicable, or consult qualified building designer as per ANSI/TPI 1.
- TCLL: ASCE 7-16; Pr=20.0 psf (roof LL: Lum DOL=1.15 Plate DOL=1.15); Pf=20.0 psf (Lum DOL=1.15 Plate DOL=1.15); Is=1.0; Rough Cat B; Fully Exp.; Ce=0.9; Cs=1.00; Ct=1.10
- Unbalanced snow loads have been considered for this design.
- Gable requires continuous bottom chord bearing.
- Gable studs spaced at 4-0-0 oc.
- This truss has been designed for a 10.0 psf bottom chord live load nonconcurrent with any other live loads.
- * This truss has been designed for a live load of 20.0psf on the bottom chord in all areas where a rectangle 3-06-00 tall by 2-00-00 wide will fit between the bottom chord and any other members, with BCDL = 10.0psf.
- Provide mechanical connection (by others) of truss to bearing plate capable of withstanding 24 lb uplift at joint 1, 158 lb uplift at joint 8 and 155 lb uplift at joint 6.
- This truss is designed in accordance with the 2018 International Residential Code sections R502.11.1 and R802.10.2 and referenced standard ANSI/TPI 1.

LOAD CASE(S) Standard

- NOTES**
- Unbalanced roof live loads have been considered for this design.
 - Wind: ASCE 7-16; Vult=130mph (3-second gust) Vasd=103mph; TCDL=6.0psf; BCDL=6.0psf; h=25ft; Cat. II; Exp B; Enclosed; MWFRS (envelope) exterior zone and C-C Exterior(2E) 0-0-5 to 3-3-6, Interior (1) 3-3-6 to 4-3-6, Exterior(2R) 4-3-6 to 10-3-6, Interior (1) 10-3-6 to 11-3-6, Exterior(2E) 11-3-6 to 14-6-8 zone; cantilever left and right exposed ; end vertical left and right exposed;C-C for members and forces & MWFRS for reactions shown; Lumber DOL=1.60 plate grip DOL=1.60

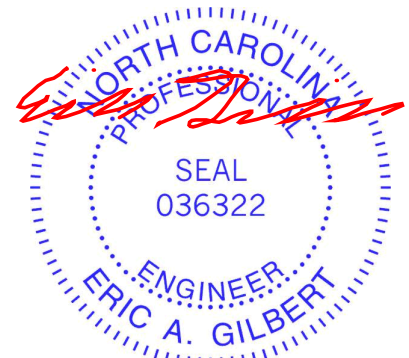

April 14, 2023

WARNING - Verify design parameters and READ NOTES ON THIS AND INCLUDED MITEK REFERENCE PAGE MII-7473 rev. 5/19/2020 BEFORE USE.

Design valid for use only with MiTek® connectors. This design is based only upon parameters shown, and is for an individual building component, not a truss system. Before use, the building designer must verify the applicability of design parameters and properly incorporate this design into the overall building design. Bracing indicated is to prevent buckling of individual truss web and/or chord members only. Additional temporary and permanent bracing is always required for stability and to prevent collapse with possible personal injury and property damage. For general guidance regarding the fabrication, storage, delivery, erection and bracing of trusses and truss systems, see ANSITPI1 Quality Criteria, DSB-89 and BCSI Building Component Safety Information available from Truss Plate Institute, 2670 Crain Highway, Suite 203 Waldorf, MD 20601



818 Soundside Road
Edenton, NC 27932

Job 23040053-01	Truss V13	Truss Type Valley	Qty 1	Ply 1	David Weekly-11 Serenity-Roof-B326 A Job Reference (optional)	157767137
--------------------	--------------	----------------------	----------	----------	--	-----------

Carter Components (Sanford), Sanford, NC - 27332,

Run: 8.53 S Mar 9 2023 Print: 8.530 S Mar 9 2023 MiTek Industries, Inc. Thu Apr 13 16:17:24
ID:kUxM45s?bF21LX?KCRTRFVAzRQqU-RfC?PsB70Hq3NSgPqnL8w3ulTXbGKWrCDoi7J4zJC?f

Page: 1

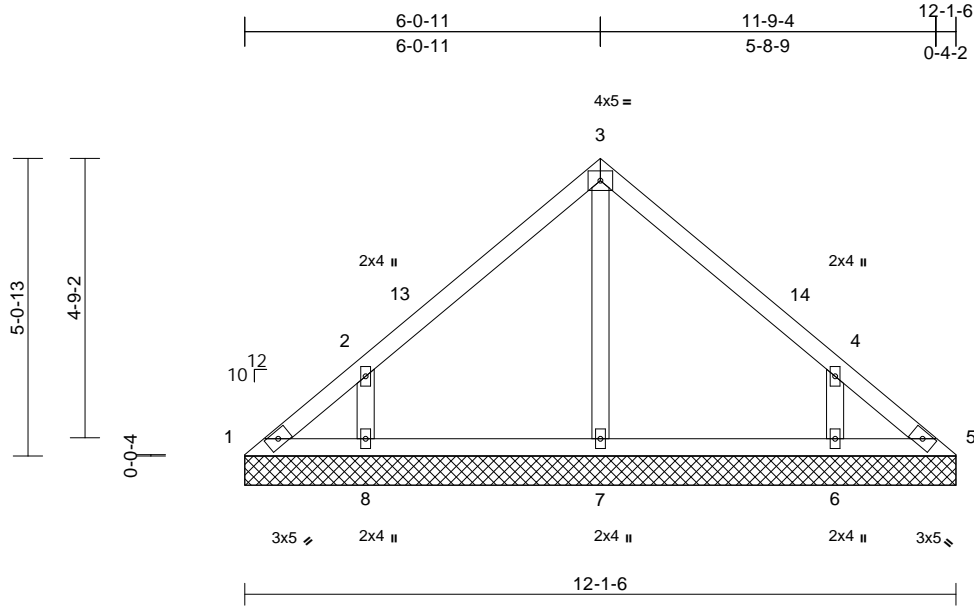

Scale = 1:39.3

Loading	(psf)	Spacing	2-0-0	CSI	DEFL	in	(loc)	l/defl	L/d	PLATES	GRIP	
TCLL (roof)	20.0	Plate Grip DOL	1.15	TC	0.31	Vert(LL)	n/a	-	n/a	999	MT20	244/190
Snow (Pf)	20.0	Lumber DOL	1.15	BC	0.12	Vert(TL)	n/a	-	n/a	999		
TCDL	10.0	Rep Stress Incr	YES	WB	0.08	Horiz(TL)	0.00	5	n/a	n/a		
BCLL	0.0*	Code	IRC2018/TPI2014	Matrix-MSH								
BCDL	10.0											
										Weight: 50 lb	FT = 20%	

LUMBER

TOP CHORD 2x4 SP No.2
BOT CHORD 2x4 SP No.2
OTHERS 2x4 SP No.3

BRACING

TOP CHORD Structural wood sheathing directly applied or 6-0-0 oc purlins.
BOT CHORD Rigid ceiling directly applied or 10-0-0 oc bracing.

REACTIONS

(size) 1=12-1-6, 5=12-1-6, 6=12-1-6, 7=12-1-6, 8=12-1-6
Max Horiz 1=-115 (LC 10)
Max Uplift 1=-33 (LC 10), 5=-5 (LC 11), 6=-136 (LC 15), 8=-140 (LC 14)
Max Grav 1=93 (LC 24), 5=72 (LC 23), 6=434 (LC 21), 7=261 (LC 21), 8=434 (LC 20)

FORCES

(lb) - Maximum Compression/Maximum Tension

TOP CHORD 1-2=-116/101, 2-3=-217/116, 3-4=-217/116, 4-5=-90/63
BOT CHORD 1-8=-32/78, 7-8=-31/73, 6-7=-31/73, 5-6=-31/73
WEBS 3-7=-173/0, 2-8=-398/218, 4-6=-398/218

NOTES

- 1) Unbalanced roof live loads have been considered for this design.
- 2) Wind: ASCE 7-16; Vult=130mph (3-second gust) Vasd=103mph; TCDL=6.0psf; BCDL=6.0psf; h=25ft; Cat. II; Exp B; Enclosed; MWFRS (envelope) exterior zone and C-C Exterior(2E) 0-0-5 to 3-0-5, Exterior(2R) 3-0-5 to 9-1-11, Exterior(2E) 9-1-11 to 12-1-11 zone; cantilever left and right exposed ; end vertical left and right exposed;C-C for members and forces & MWFRS for reactions shown; Lumber DOL=1.60 plate grip DOL=1.60

- 3) Truss designed for wind loads in the plane of the truss only. For studs exposed to wind (normal to the face), see Standard Industry Gable End Details as applicable, or consult qualified building designer as per ANSI/TPI 1.
- 4) TCLL: ASCE 7-16; Pr=20.0 psf (roof LL: Lum DOL=1.15 Plate DOL=1.15); Pf=20.0 psf (Lum DOL=1.15 Plate DOL=1.15); Is=1.0; Rough Cat B; Fully Exp.; Ce=0.9; Cs=1.00; Ct=1.10
- 5) Unbalanced snow loads have been considered for this design.
- 6) Gable requires continuous bottom chord bearing.
- 7) Gable studs spaced at 4-0-0 oc.
- 8) This truss has been designed for a 10.0 psf bottom chord live load nonconcurrent with any other live loads.
- 9) * This truss has been designed for a live load of 20.0psf on the bottom chord in all areas where a rectangle 3-06-00 tall by 2-00-00 wide will fit between the bottom chord and any other members.
- 10) Provide mechanical connection (by others) of truss to bearing plate capable of withstanding 33 lb uplift at joint 1, 5 lb uplift at joint 5, 140 lb uplift at joint 8 and 136 lb uplift at joint 6.
- 11) This truss is designed in accordance with the 2018 International Residential Code sections R502.11.1 and R802.10.2 and referenced standard ANSI/TPI 1.

LOAD CASE(S) Standard

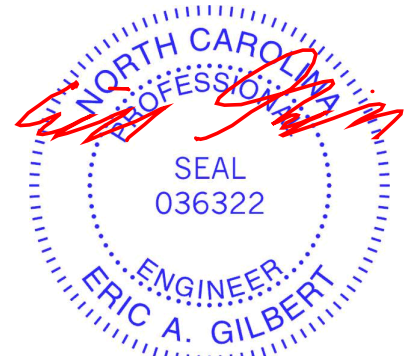

April 14, 2023

WARNING - Verify design parameters and READ NOTES ON THIS AND INCLUDED MITEK REFERENCE PAGE MII-7473 rev. 5/19/2020 BEFORE USE.

Design valid for use only with MiTek® connectors. This design is based only upon parameters shown, and is for an individual building component, not a truss system. Before use, the building designer must verify the applicability of design parameters and properly incorporate this design into the overall building design. Bracing indicated is to prevent buckling of individual truss web and/or chord members only. Additional temporary and permanent bracing is always required for stability and to prevent collapse with possible personal injury and property damage. For general guidance regarding the fabrication, storage, delivery, erection and bracing of trusses and truss systems, see **ANSI/TPI1 Quality Criteria, DSB-89 and BCSI Building Component Safety Information** available from Truss Plate Institute, 2670 Crain Highway, Suite 203 Waldorf, MD 20601



818 Soundside Road
Edenton, NC 27932

Job 23040053-01	Truss V14	Truss Type Valley	Qty 1	Ply 1	David Weekly-11 Serenity-Roof-B326 A Job Reference (optional)	157767138
--------------------	--------------	----------------------	----------	----------	--	-----------

Carter Components (Sanford), Sanford, NC - 27332,

Run: 8.53 S Mar 9 2023 Print: 8.530 S Mar 9 2023 MiTek Industries, Inc. Thu Apr 13 16:17:24
ID:kUxM45s?bF21LX?KCRTFVazRQqU-RfC?PsB70Hq3NSgPqnL8w3ulTXbGKWrCDoi7J4zJC?f

Page: 1

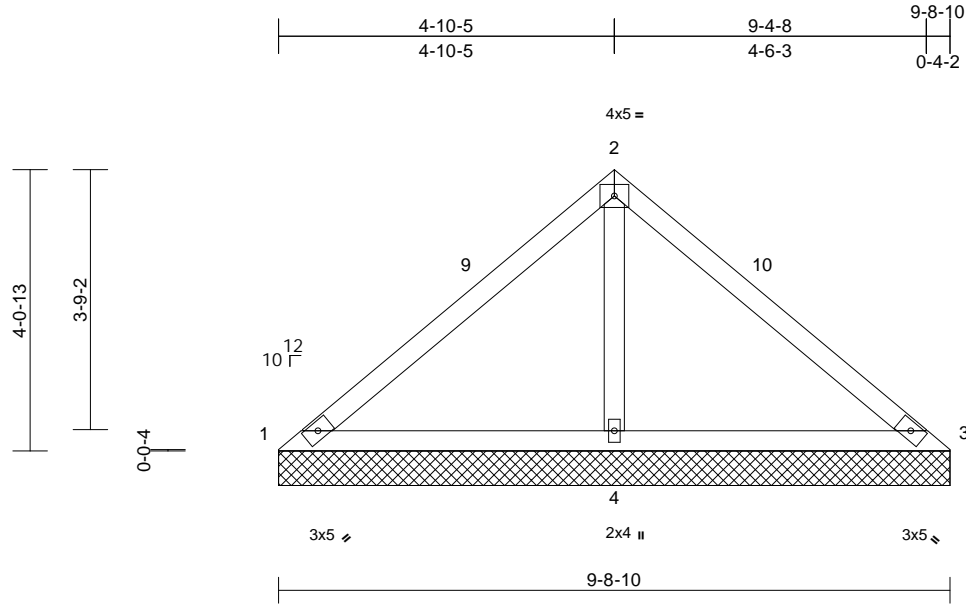

Scale = 1:33.3

Loading	(psf)	Spacing	2-0-0	CSI	DEFL	in	(loc)	l/defl	L/d	PLATES	GRIP	
TCLL (roof)	20.0	Plate Grip DOL	1.15	TC	0.46	Vert(LL)	n/a	-	n/a	999	MT20	244/190
Snow (Pf)	20.0	Lumber DOL	1.15	BC	0.43	Vert(TL)	n/a	-	n/a	999		
TCDL	10.0	Rep Stress Incr	YES	WB	0.19	Horiz(TL)	0.01	4	n/a	n/a		
BCLL	0.0*	Code	IRC2018/TPI2014	Matrix-MSH								
BCDL	10.0											
											Weight: 37 lb	FT = 20%

LUMBER

TOP CHORD 2x4 SP No.2
BOT CHORD 2x4 SP No.2
OTHERS 2x4 SP No.3

BRACING

TOP CHORD Structural wood sheathing directly applied or 9-8-10 oc purlins.
BOT CHORD Rigid ceiling directly applied or 6-0-0 oc bracing.

REACTIONS

(size) 1=9-8-10, 3=9-8-10, 4=9-8-10
Max Horiz 1=-91 (LC 10)
Max Uplift 1=-51 (LC 21), 3=-51 (LC 20), 4=-110 (LC 14)
Max Grav 1=95 (LC 20), 3=95 (LC 21), 4=784 (LC 21)

FORCES

(lb) - Maximum Compression/Maximum Tension

TOP CHORD 1-2=-117/380, 2-3=-117/380
BOT CHORD 1-4=-217/174, 3-4=-217/174
WEBS 2-4=-605/274

NOTES

- 1) Unbalanced roof live loads have been considered for this design.
- 2) Wind: ASCE 7-16; Vult=130mph (3-second gust) Vasd=103mph; TCDL=6.0psf; BCDL=6.0psf; h=25ft; Cat. II; Exp B; Enclosed; MWFRS (envelope) exterior zone and C-C Exterior(2E) 0-0-5 to 3-0-5, Exterior(2R) 3-0-5 to 6-8-14, Exterior(2E) 6-8-14 to 9-8-14 zone; cantilever left and right exposed; end vertical left and right exposed; C-C for members and forces & MWFRS for reactions shown; Lumber DOL=1.60 plate grip DOL=1.60
- 3) Truss designed for wind loads in the plane of the truss only. For studs exposed to wind (normal to the face), see Standard Industry Gable End Details as applicable, or consult qualified building designer as per ANSI/TPI 1.

- 4) TCLL: ASCE 7-16; Pr=20.0 psf (roof LL: Lum DOL=1.15 Plate DOL=1.15); Pf=20.0 psf (Lum DOL=1.15 Plate DOL=1.15); Is=1.0; Rough Cat B; Fully Exp.; Ce=0.9; Cs=1.00; Ct=1.10
- 5) Unbalanced snow loads have been considered for this design.
- 6) Gable requires continuous bottom chord bearing.
- 7) Gable studs spaced at 4-0-0 oc.
- 8) This truss has been designed for a 10.0 psf bottom chord live load nonconcurrent with any other live loads.
- 9) * This truss has been designed for a live load of 20.0psf on the bottom chord in all areas where a rectangle 3-06-00 tall by 2-00-00 wide will fit between the bottom chord and any other members.
- 10) Provide mechanical connection (by others) of truss to bearing plate capable of withstanding 51 lb uplift at joint 1, 51 lb uplift at joint 3 and 110 lb uplift at joint 4.
- 11) This truss is designed in accordance with the 2018 International Residential Code sections R502.11.1 and R802.10.2 and referenced standard ANSI/TPI 1.

LOAD CASE(S) Standard



April 14, 2023

WARNING - Verify design parameters and READ NOTES ON THIS AND INCLUDED MITEK REFERENCE PAGE MII-7473 rev. 5/19/2020 BEFORE USE.

Design valid for use only with MiTek® connectors. This design is based only upon parameters shown, and is for an individual building component, not a truss system. Before use, the building designer must verify the applicability of design parameters and properly incorporate this design into the overall building design. Bracing indicated is to prevent buckling of individual truss web and/or chord members only. Additional temporary and permanent bracing is always required for stability and to prevent collapse with possible personal injury and property damage. For general guidance regarding the fabrication, storage, delivery, erection and bracing of trusses and truss systems, see

ANSI/TPI1 Quality Criteria, DSB-89 and BCSI Building Component

Safety Information available from Truss Plate Institute, 2670 Crain Highway, Suite 203 Waldorf, MD 20601



818 Soundside Road
Edenton, NC 27932

Job 23040053-01	Truss V15	Truss Type Valley	Qty 1	Ply 1	David Weekly-11 Serenity-Roof-B326 A Job Reference (optional)	157767139
--------------------	--------------	----------------------	----------	----------	--	-----------

Carter Components (Sanford), Sanford, NC - 27332,

Run: 8.53 S Mar 9 2023 Print: 8.530 S Mar 9 2023 MiTek Industries, Inc. Thu Apr 13 16:17:25

Page: 1

ID:CgVkhRtdMZAuzhaXm9_U1OzRQqT-RFC?PsB70Hq3NSgPqnL8w3uITXbGKWrCDoi7J4zJC?f

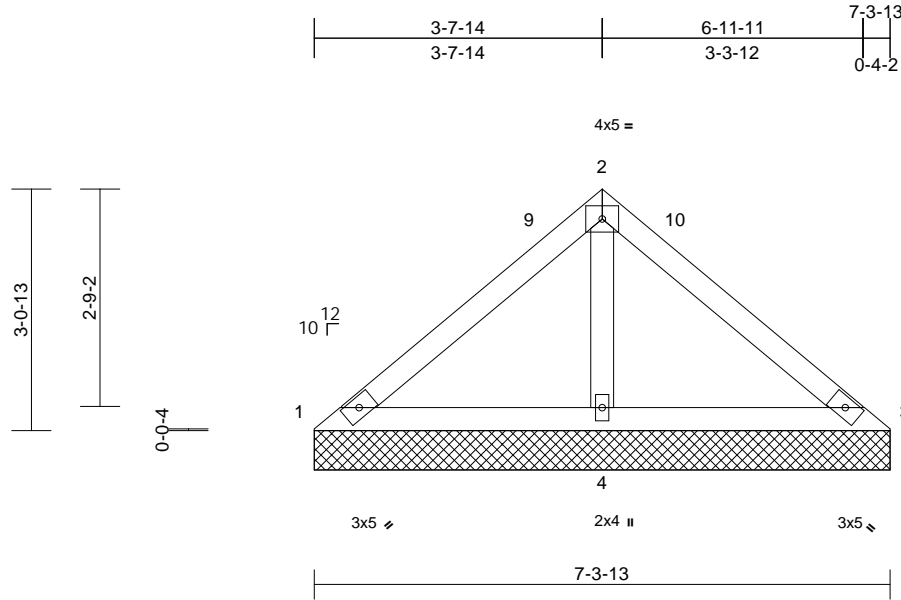

Loading	(psf)	Spacing	2-0-0	CSI	DEFL	in	(loc)	l/defl	L/d	PLATES	GRIP	
TCLL (roof)	20.0	Plate Grip DOL	1.15	TC	0.26	Vert(LL)	n/a	-	n/a	999	MT20	244/190
Snow (Pf)	20.0	Lumber DOL	1.15	BC	0.27	Vert(TL)	n/a	-	n/a	999		
TCDL	10.0	Rep Stress Incr	YES	WB	0.09	Horiz(TL)	0.00	4	n/a	n/a		
BCLL	0.0*	Code	IRC2018/TPI2014	Matrix-MP								
BCDL	10.0											
											Weight: 27 lb	FT = 20%

LUMBER
TOP CHORD 2x4 SP No.2
BOT CHORD 2x4 SP No.2
OTHERS 2x4 SP No.3

BRACING
TOP CHORD Structural wood sheathing directly applied or 7-3-13 oc purlins.
BOT CHORD Rigid ceiling directly applied or 6-0-0 oc bracing.

REACTIONS (size) 1=7-3-13, 3=7-3-13, 4=7-3-13
Max Horiz 1=-68 (LC 12)
Max Uplift 1=-19 (LC 21), 3=-19 (LC 20), 4=-75 (LC 14)
Max Grav 1=105 (LC 20), 3=105 (LC 21), 4=541 (LC 21)

FORCES (lb) - Maximum Compression/Maximum Tension
TOP CHORD 1-2=-91/234, 2-3=-91/234
BOT CHORD 1-4=-164/154, 3-4=-164/154
WEBS 2-4=-387/203

- TCLL: ASCE 7-16; Pr=20.0 psf (roof LL: Lum DOL=1.15 Plate DOL=1.15); Pf=20.0 psf (Lum DOL=1.15 Plate DOL=1.15); Is=1.0; Rough Cat B; Fully Exp.; Ce=0.9; Cs=1.00; Ct=1.10
- Unbalanced snow loads have been considered for this design.
- Gable requires continuous bottom chord bearing.
- Gable studs spaced at 4-0-0 oc.
- This truss has been designed for a 10.0 psf bottom chord live load nonconcurrent with any other live loads.
- * This truss has been designed for a live load of 20.0psf on the bottom chord in all areas where a rectangle 3-06-00 tall by 2-00-00 wide will fit between the bottom chord and any other members.
- Provide mechanical connection (by others) of truss to bearing plate capable of withstanding 19 lb uplift at joint 1, 19 lb uplift at joint 3 and 75 lb uplift at joint 4.
- This truss is designed in accordance with the 2018 International Residential Code sections R502.11.1 and R802.10.2 and referenced standard ANSI/TPI 1.

LOAD CASE(S) Standard

NOTES

- Unbalanced roof live loads have been considered for this design.
- Wind: ASCE 7-16; Vult=130mph (3-second gust) Vasd=103mph; TCDL=6.0psf; BCDL=6.0psf; h=25ft; Cat. II; Exp B; Enclosed; MWFRS (envelope) exterior zone and C-C Exterior(2E) 0-0-5 to 3-0-5, Exterior(2R) 3-0-5 to 4-4-2, Exterior(2E) 4-4-2 to 7-4-2 zone; cantilever left and right exposed; end vertical left and right exposed; C-C for members and forces & MWFRS for reactions shown; Lumber DOL=1.60 plate grip DOL=1.60
- Truss designed for wind loads in the plane of the truss only. For studs exposed to wind (normal to the face), see Standard Industry Gable End Details as applicable, or consult qualified building designer as per ANSI/TPI 1.



April 14, 2023

WARNING - Verify design parameters and READ NOTES ON THIS AND INCLUDED MITEK REFERENCE PAGE MII-7473 rev. 5/19/2020 BEFORE USE.

Design valid for use only with MiTek® connectors. This design is based only upon parameters shown, and is for an individual building component, not a truss system. Before use, the building designer must verify the applicability of design parameters and properly incorporate this design into the overall building design. Bracing indicated is to prevent buckling of individual truss web and/or chord members only. Additional temporary and permanent bracing is always required for stability and to prevent collapse with possible personal injury and property damage. For general guidance regarding the fabrication, storage, delivery, erection and bracing of trusses and truss systems, see

ANSI/TPI1 Quality Criteria, DSB-89 and BCSI Building Component

Safety Information available from Truss Plate Institute, 2670 Crain Highway, Suite 203 Waldorf, MD 20601



818 Soundside Road
Edenton, NC 27932

Job 23040053-01	Truss V16	Truss Type Valley	Qty 1	Ply 1	David Weekly-11 Serenity-Roof-B326 A Job Reference (optional)	157767140
--------------------	--------------	----------------------	----------	----------	--	-----------

Carter Components (Sanford), Sanford, NC - 27332,

Run: 8.53 S Mar 9 2023 Print: 8.530 S Mar 9 2023 MiTek Industries, Inc. Thu Apr 13 16:17:25
ID:CgVkhRtdMZAuzhaXm9_U1OzRQqT-RFC?PsB70Hq3NSgPqnL8w3uITXbGKWrCDoi7J4zJC?f

Page: 1

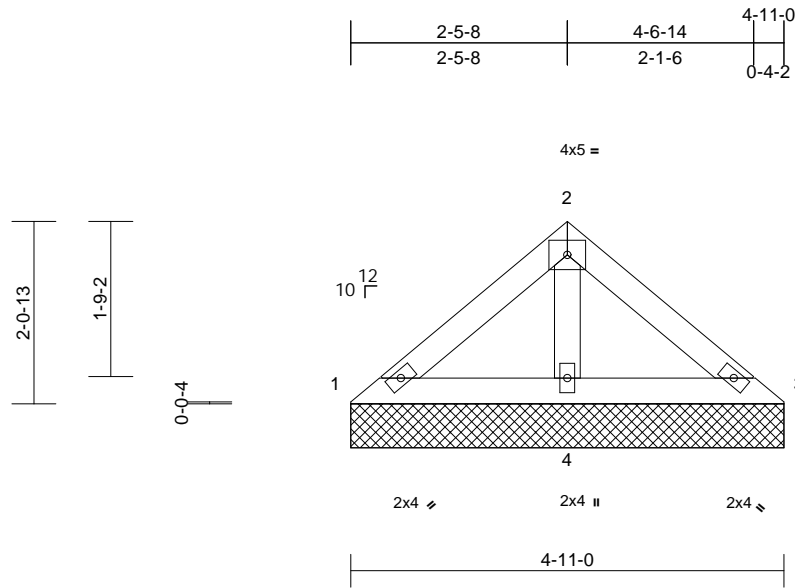

Scale = 1:26.2

Loading	(psf)	Spacing	2-0-0	CSI	DEFL	in	(loc)	l/defl	L/d	PLATES	GRIP	
TCLL (roof)	20.0	Plate Grip DOL	1.15	TC	0.09	Vert(LL)	n/a	-	n/a	999	MT20	244/190
Snow (Pf)	20.0	Lumber DOL	1.15	BC	0.11	Vert(TL)	n/a	-	n/a	999		
TCDL	10.0	Rep Stress Incr	YES	WB	0.04	Horiz(TL)	0.00	4	n/a	n/a		
BCLL	0.0*	Code	IRC2018/TPI2014	Matrix-MP								
BCDL	10.0											
										Weight: 18 lb	FT = 20%	

LUMBER

TOP CHORD 2x4 SP No.2
BOT CHORD 2x4 SP No.2
OTHERS 2x4 SP No.3

BRACING

TOP CHORD Structural wood sheathing directly applied or 4-11-0 oc purlins.
BOT CHORD Rigid ceiling directly applied or 6-0-0 oc bracing.

REACTIONS

(size) 1=4-11-0, 3=4-11-0, 4=4-11-0
Max Horiz 1=-44 (LC 10)
Max Uplift 3=-7 (LC 15), 4=-34 (LC 14)
Max Grav 1=89 (LC 20), 3=89 (LC 21), 4=301 (LC 20)

FORCES

(lb) - Maximum Compression/Maximum Tension

TOP CHORD 1-2=-81/106, 2-3=-81/106
BOT CHORD 1-4=-82/90, 3-4=-82/90
WEBS 2-4=-187/100

NOTES

- Unbalanced roof live loads have been considered for this design.
- Wind: ASCE 7-16; Vult=130mph (3-second gust) Vasd=103mph; TCDL=6.0psf; BCDL=6.0psf; h=25ft; Cat. II; Exp B; Enclosed; MWFRS (envelope) exterior zone and C-C Exterior(2E) zone; cantilever left and right exposed; end vertical left and right exposed; C-C for members and forces & MWFRS for reactions shown; Lumber DOL=1.60 plate grip DOL=1.60
- Truss designed for wind loads in the plane of the truss only. For studs exposed to wind (normal to the face), see Standard Industry Gable End Details as applicable, or consult qualified building designer as per ANSI/TPI 1.
- TCLL: ASCE 7-16; Pr=20.0 psf (roof LL: Lum DOL=1.15 Plate DOL=1.15); Pf=20.0 psf (Lum DOL=1.15 Plate DOL=1.15); Is=1.0; Rough Cat B; Fully Exp.; Ce=0.9; Cs=1.00; Ct=1.10

- Unbalanced snow loads have been considered for this design.
- Gable requires continuous bottom chord bearing.
- Gable studs spaced at 4-0-0 oc.
- This truss has been designed for a 10.0 psf bottom chord live load nonconcurrent with any other live loads.
- * This truss has been designed for a live load of 20.0psf on the bottom chord in all areas where a rectangle 3-06-00 tall by 2-00-00 wide will fit between the bottom chord and any other members.
- Provide mechanical connection (by others) of truss to bearing plate capable of withstanding 7 lb uplift at joint 3 and 34 lb uplift at joint 4.
- This truss is designed in accordance with the 2018 International Residential Code sections R502.11.1 and R802.10.2 and referenced standard ANSI/TPI 1.

LOAD CASE(S) Standard



April 14, 2023

WARNING - Verify design parameters and READ NOTES ON THIS AND INCLUDED MITEK REFERENCE PAGE MII-7473 rev. 5/19/2020 BEFORE USE.

Design valid for use only with MiTek® connectors. This design is based only upon parameters shown, and is for an individual building component, not a truss system. Before use, the building designer must verify the applicability of design parameters and properly incorporate this design into the overall building design. Bracing indicated is to prevent buckling of individual truss web and/or chord members only. Additional temporary and permanent bracing is always required for stability and to prevent collapse with possible personal injury and property damage. For general guidance regarding the fabrication, storage, delivery, erection and bracing of trusses and truss systems, see

ANSI/TPI1 Quality Criteria, DSB-89 and BCSI Building Component

Safety Information available from Truss Plate Institute, 2670 Crain Highway, Suite 203 Waldorf, MD 20601

ENGINEERING BY
TRENCO
A MiTek Affiliate

818 Soundside Road
Edenton, NC 27932

Job	Truss	Truss Type	Qty	Ply	David Weekly-11 Serenity-Roof-B326 A	I57767141
23040053-01	V17	Valley	1	1	Job Reference (optional)	

Carter Components (Sanford), Sanford, NC - 27332,

Run: 8.53 S Mar 9 2023 Print: 8.530 S Mar 9 2023 MiTek Industries, Inc. Thu Apr 13 16:17:26

Page: 1

ID:CgVkhRtdMZAuzhaXm9_U1OzRQqT-RFC?PsB70Hq3NSgPqnL8w3uITXbGKWRcDoi7J4zJC?#

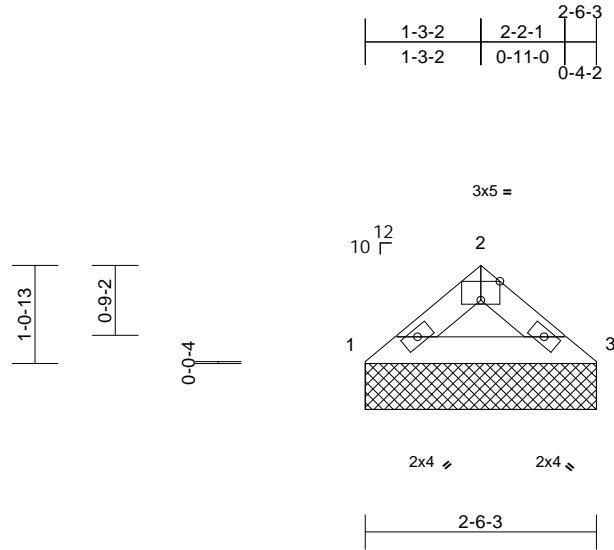

Scale = 1:25.1

Plate Offsets (X, Y): [2:0-2-8,Edge]

Loading	(psf)	Spacing	2-0-0	CSI	DEFL	in	(loc)	l/defl	L/d	PLATES	GRIP	
TCLL (roof)	20.0	Plate Grip DOL	1.15	TC	0.05	Vert(LL)	n/a	-	n/a	999	MT20	244/190
Snow (Pf)	20.0	Lumber DOL	1.15	BC	0.05	Vert(TL)	n/a	-	n/a	999		
TCDL	10.0	Rep Stress Incr	YES	WB	0.00	Horiz(TL)	0.00	3	n/a	n/a		
BCLL	0.0*	Code	IRC2018/TPI2014	Matrix-MP								
BCDL	10.0											
										Weight: 7 lb	FT = 20%	

LUMBER

TOP CHORD 2x4 SP No.2
BOT CHORD 2x4 SP No.2

BRACING

TOP CHORD Structural wood sheathing directly applied or 2-6-3 oc purlins.
BOT CHORD Rigid ceiling directly applied or 10-0-0 oc bracing.

REACTIONS

(size) 1=2-6-3, 3=2-6-3
Max Horiz 1=21 (LC 11)
Max Uplift 1=-9 (LC 14), 3=-9 (LC 15)
Max Grav 1=114 (LC 20), 3=114 (LC 21)

FORCES

(lb) - Maximum Compression/Maximum Tension

TOP CHORD 1-2=-137/62, 2-3=-137/62
BOT CHORD 1-3=-33/99

NOTES

- 1) Unbalanced roof live loads have been considered for this design.
- 2) Wind: ASCE 7-16; Vult=130mph (3-second gust) Vasd=103mph; TCDL=6.0psf; BCDL=6.0psf; h=25ft; Cat. II; Exp B; Enclosed; MWFRS (envelope) exterior zone and C-C Exterior(2E) zone; cantilever left and right exposed; end vertical left and right exposed; C-C for members and forces & MWFRS for reactions shown; Lumber DOL=1.60 plate grip DOL=1.60
- 3) Truss designed for wind loads in the plane of the truss only. For studs exposed to wind (normal to the face), see Standard Industry Gable End Details as applicable, or consult qualified building designer as per ANSI/TPI 1.
- 4) TCLL: ASCE 7-16; Pr=20.0 psf (roof LL: Lum DOL=1.15 Plate DOL=1.15); Pf=20.0 psf (Lum DOL=1.15 Plate DOL=1.15); Is=1.0; Rough Cat B; Fully Exp.; Ce=0.9; Cs=1.00; Ct=1.10
- 5) Unbalanced snow loads have been considered for this design.
- 6) Gable requires continuous bottom chord bearing.

- 7) Gable studs spaced at 4-0-0 oc.
- 8) This truss has been designed for a 10.0 psf bottom chord live load nonconcurrent with any other live loads.
- 9) * This truss has been designed for a live load of 20.0psf on the bottom chord in all areas where a rectangle 3-06-00 tall by 2-00-00 wide will fit between the bottom chord and any other members.
- 10) Provide mechanical connection (by others) of truss to bearing plate capable of withstanding 9 lb uplift at joint 1 and 9 lb uplift at joint 3.
- 11) This truss is designed in accordance with the 2018 International Residential Code sections R502.11.1 and R802.10.2 and referenced standard ANSI/TPI 1.

LOAD CASE(S) Standard

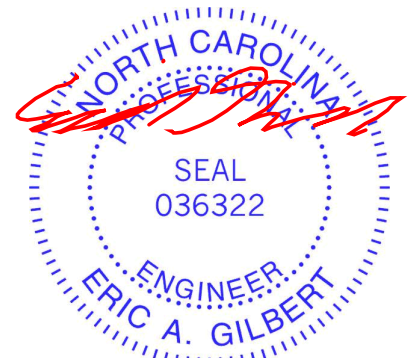

April 14, 2023

WARNING - Verify design parameters and READ NOTES ON THIS AND INCLUDED MITEK REFERENCE PAGE MII-7473 rev. 5/19/2020 BEFORE USE.

Design valid for use only with MiTek® connectors. This design is based only upon parameters shown, and is for an individual building component, not a truss system. Before use, the building designer must verify the applicability of design parameters and properly incorporate this design into the overall building design. Bracing indicated is to prevent buckling of individual truss web and/or chord members only. Additional temporary and permanent bracing is always required for stability and to prevent collapse with possible personal injury and property damage. For general guidance regarding the fabrication, storage, delivery, erection and bracing of trusses and truss systems, see **ANSI/TPI1 Quality Criteria, DSB-89 and BCSI Building Component Safety Information** available from Truss Plate Institute, 2670 Crain Highway, Suite 203 Waldorf, MD 20601



818 Soundside Road
Edenton, NC 27932

Symbols

PLATE LOCATION AND ORIENTATION



Center plate on joint unless x, y offsets are indicated. Dimensions are in ft-in-sixteenths. Apply plates to both sides of truss and fully embed teeth.

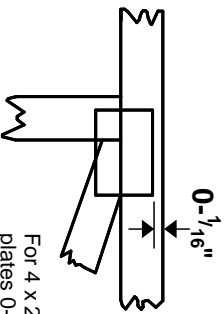

For 4 x 2 orientation, locate plates 0- 1/16" from outside edge of truss.



This symbol indicates the required direction of slots in connector plates.

* Plate location details available in **MITek 20/20 software** or upon request.

PLATE SIZE

4 X 4

The first dimension is the plate width measured perpendicular to slots. Second dimension is the length parallel to slots.

LATERAL BRACING LOCATION

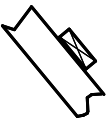

Indicated by symbol shown and/or by text in the bracing section of the output. Use T or I bracing if indicated.

BEARING

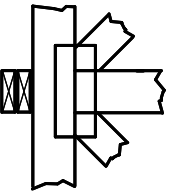

Indicates location where bearings (supports) occur. Icons vary but reaction section indicates joint number where bearings occur. Min size shown is for crushing only.

Industry Standards:

ANSI/TPI 1: National Design Specification for Metal Plate Connected Wood Truss Construction.
DSB-89: Design Standard for Bracing, Building Component Safety Information, Guide to Good Practice for Handling, Installing & Bracing of Metal Plate Connected Wood Trusses.

Numbering System

6-4-8
dimensions shown in ft-in-sixteenths
(Drawings not to scale)



JOINTS ARE GENERALLY NUMBERED/LETTERED CLOCKWISE AROUND THE TRUSS STARTING AT THE JOINT FARTHEST TO THE LEFT.

CHORDS AND WEBS ARE IDENTIFIED BY END JOINT NUMBERS/LETTERS.

PRODUCT CODE APPROVALS

ICC-ES Reports:

ESR-1311, ESR-1352, ESR1988
ER-3907, ESR-2362, ESR-1397, ESR-3282

Trusses are designed for wind loads in the plane of the truss unless otherwise shown.

Lumber design values are in accordance with ANSI/TPI 1 section 6.3 These truss designs rely on lumber values established by others.

© 2012 MITteK® All Rights Reserved



MITek Engineering Reference Sheet: MII-7473 rev. 5/19/2020



General Safety Notes

Failure to Follow Could Cause Property Damage or Personal Injury

1. Additional stability bracing for truss system, e.g. diagonal or X-bracing, is always required. See BCSI.
2. Truss bracing must be designed by an engineer. For wide truss spacing, individual lateral braces themselves may require bracing, or alternative Tor I bracing should be considered.
3. Never exceed the design loading shown and never stack materials on inadequately braced trusses.
4. Provide copies of this truss design to the building designer, erection supervisor, property owner and all other interested parties.
5. Cut members to bear tightly against each other.
6. Place plates on each face of truss at each joint and embed fully. Knots and wane at joint locations are regulated by ANSI/TPI 1.
7. Design assumes trusses will be suitably protected from the environment in accord with ANSI/TPI 1.
8. Unless otherwise noted, moisture content of lumber shall not exceed 19% at time of fabrication.
9. Unless expressly noted, this design is not applicable for use with fire retardant, preservative treated, or green lumber.
10. Camber is a non-structural consideration and is the responsibility of truss fabricator. General practice is to camber for dead load deflection.
11. Plate type, size, orientation and location dimensions indicated are minimum plating requirements.
12. Lumber used shall be of the species and size, and in all respects, equal to or better than that specified.
13. Top chords must be sheathed or purlins provided at spacing indicated on design.
14. Bottom chords require lateral bracing at 10 ft. spacing, or less, if no ceiling is installed, unless otherwise noted.
15. Connections not shown are the responsibility of others.
16. Do not cut or alter truss member or plate without prior approval of an engineer.
17. Install and load vertically unless indicated otherwise.
18. Use of green or treated lumber may pose unacceptable environmental, health or performance risks. Consult with project engineer before use.
19. Review all portions of this design (front, back, words and pictures) before use. Rewriting pictures alone is not sufficient.
20. Design assumes manufacture in accordance with ANSI/TPI 1 Quality Criteria.
21. The design does not take into account any dynamic or other loads other than those expressly stated.