

RE: 36029A
 57 SERENITY

Trenco
 818 Soundside Rd
 Edenton, NC 27932

Site Information:

Customer: Project Name: 36029A
 Lot/Block:
 Address:
 City:

Model:
 Subdivision:
 State:

General Truss Engineering Criteria & Design Loads (Individual Truss Design Drawings Show Special Loading Conditions):

Design Code: IRC2015/TPI2014
 Wind Code: ASCE 7-10
 Roof Load: 40.0 psf

Design Program: MiTek 20/20 8.6
 Wind Speed: 115 mph
 Floor Load: N/A psf

This package includes 54 individual, dated Truss Design Drawings and 0 Additional Drawings.

No.	Seal#	Truss Name	Date	No.	Seal#	Truss Name	Date
1	I56131948	A1E	1/17/2023	21	I56131968	H1	1/17/2023
2	I56131949	A2	1/17/2023	22	I56131969	H2	1/17/2023
3	I56131950	A2A	1/17/2023	23	I56131970	H3G	1/17/2023
4	I56131951	A3A	1/17/2023	24	I56131971	H4	1/17/2023
5	I56131952	A4A	1/17/2023	25	I56131972	J1	1/17/2023
6	I56131953	A5E	1/17/2023	26	I56131973	J2	1/17/2023
7	I56131954	B1E	1/17/2023	27	I56131974	J3	1/17/2023
8	I56131955	B2	1/17/2023	28	I56131975	J4	1/17/2023
9	I56131956	B3	1/17/2023	29	I56131976	J5	1/17/2023
10	I56131957	B4G	1/17/2023	30	I56131977	M1	1/17/2023
11	I56131958	C1	1/17/2023	31	I56131978	M2	1/17/2023
12	I56131959	C2	1/17/2023	32	I56131979	M3	1/17/2023
13	I56131960	C2A	1/17/2023	33	I56131980	M4	1/17/2023
14	I56131961	C3	1/17/2023	34	I56131981	PB1	1/17/2023
15	I56131962	C4E	1/17/2023	35	I56131982	PB2	1/17/2023
16	I56131963	D1E	1/17/2023	36	I56131983	V1	1/17/2023
17	I56131964	D2	1/17/2023	37	I56131984	V2	1/17/2023
18	I56131965	E1E	1/17/2023	38	I56131985	V3	1/17/2023
19	I56131966	E2G	1/17/2023	39	I56131986	V4	1/17/2023
20	I56131967	FG1	1/17/2023	40	I56131987	V5	1/17/2023

The truss drawing(s) referenced above have been prepared by Truss Engineering Co. under my direct supervision based on the parameters provided by 84 Components - #2383.

Truss Design Engineer's Name: Gilbert, Eric

My license renewal date for the state of North Carolina is December 31, 2023.

North Carolina COA: C-0844

IMPORTANT NOTE: The seal on these truss component designs is a certification that the engineer named is licensed in the jurisdiction(s) identified and that the designs comply with ANSI/TPI 1. These designs are based upon parameters shown (e.g., loads, supports, dimensions, shapes and design codes), which were given to TRENCO. Any project specific information included is for TRENCO customers file reference purpose only, and was not taken into account in the preparation of these designs. TRENCO has not independently verified the applicability of the design parameters or the designs for any particular building. Before use, the building designer should verify applicability of design parameters and properly incorporate these designs into the overall building design per ANSI/TPI 1, Chapter 2.

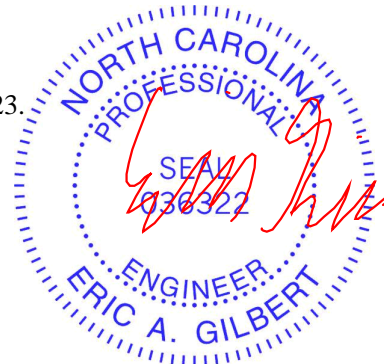

January 17, 2023

RE: 36029A - 57 SERENITY

Trenco
818 Soundside Rd
Edenton, NC 27932

Site Information:

Project Customer: Project Name: 36029A

Lot/Block:

Subdivision:

Address:

City, County:

State:

No.	Seal#	Truss Name	Date
41	I56131988	V8	1/17/2023
42	I56131989	V9	1/17/2023
43	I56131990	V10	1/17/2023
44	I56131991	V11	1/17/2023
45	I56131992	V12	1/17/2023
46	I56131993	V13	1/17/2023
47	I56131994	V15	1/17/2023
48	I56131995	V16	1/17/2023
49	I56131996	V17	1/17/2023
50	I56131997	V18	1/17/2023
51	I56131998	V19	1/17/2023
52	I56131999	V20	1/17/2023
53	I56132000	V21	1/17/2023
54	I56132001	V22	1/17/2023

Job 36029A	Truss A1E	Truss Type Common Supported Gable	Qty 1	Ply 1	57 SERENITY Job Reference (optional)	I56131948
---------------	--------------	--------------------------------------	----------	----------	---	-----------

84 Components (Dunn), Dunn, NC - 28334,

Run: 8.63 S Nov 19 2022 Print: 8.630 S Nov 19 2022 MiTek Industries, Inc. Fri Jan 13 10:16:48
ID:C1WouytSkAbxAH8_CW9Vkiy6NQX-RfC?PsB70Hq3NSgPqnL8w3uTXbGKwRCoD0i7J4zJC7f

Page: 1

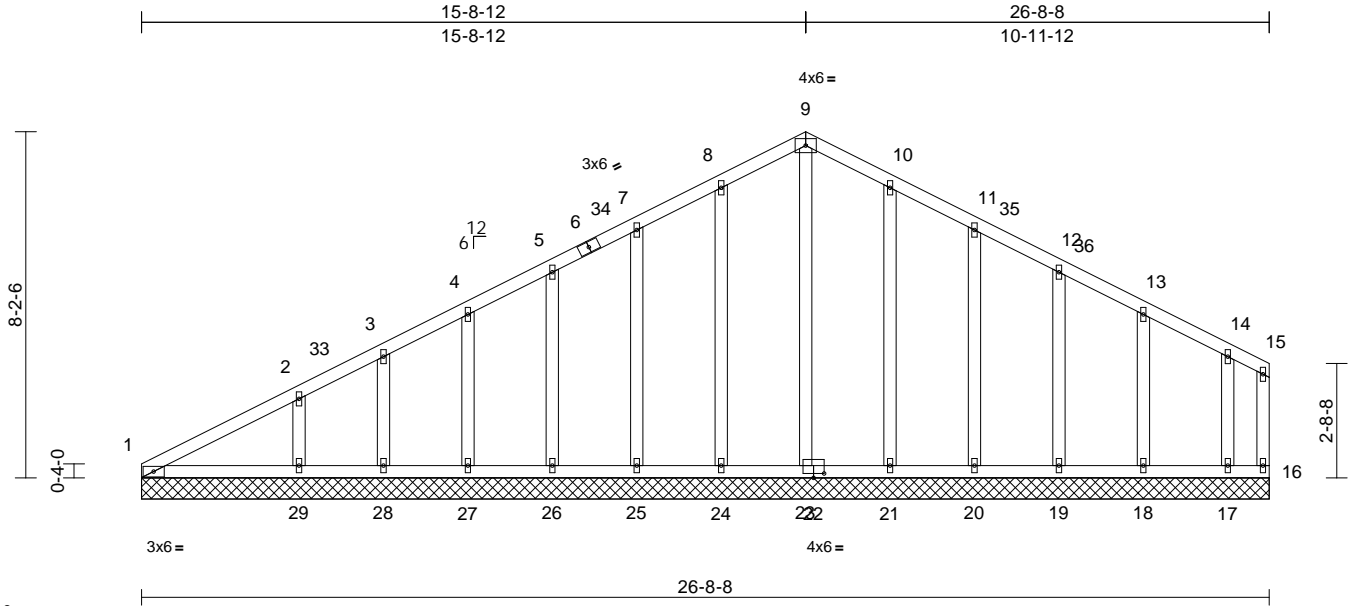

Scale = 1:54.6
Plate Offsets (X, Y): [22:0-3-0,0-1-4]

Loading	(psf)	Spacing	2-0-0	CSI	DEFL	in	(loc)	l/defl	L/d	PLATES	GRIP	
TCLL (roof)	20.0	Plate Grip DOL	1.15	TC	0.14	Vert(LL)	n/a	-	n/a	999	MT20	244/190
TCDL	10.0	Lumber DOL	1.15	BC	0.13	Vert(TL)	n/a	-	n/a	999		
BCLL	0.0*	Rep Stress Incr	YES	WB	0.18	Horiz(TL)	0.00	16	n/a	n/a		
BCDL	10.0	Code	IRC2015/TPI2014	Matrix-MS							Weight: 171 lb	FT = 20%

LUMBER	
TOP CHORD	2x4 SP No.2
BOT CHORD	2x4 SP No.2
WEBS	2x4 SP No.3
OTHERS	2x4 SP No.3 *Except* 23-9,24-8,21-10:2x4 SP No.2

BRACING	
TOP CHORD	Structural wood sheathing directly applied or 6-0-0 oc purlins, except end verticals.
BOT CHORD	Rigid ceiling directly applied or 10-0-0 oc bracing.

REACTIONS	(size)
Max Horiz	1=26-8-8, 16=26-8-8, 17=26-8-8, 18=26-8-8, 19=26-8-8, 20=26-8-8, 21=26-8-8, 23=26-8-8, 24=26-8-8, 25=26-8-8, 26=26-8-8, 27=26-8-8, 28=26-8-8, 29=26-8-8, 30=26-8-8
Max Uplift	1=128 (LC 11), 30=128 (LC 11) 1=-4 (LC 8), 16=-3 (LC 12), 17=-38 (LC 13), 18=-28 (LC 13), 19=-27 (LC 13), 20=-29 (LC 13), 21=-25 (LC 13), 24=-27 (LC 12), 25=-29 (LC 12), 26=-27 (LC 12), 27=-30 (LC 12), 28=-17 (LC 12), 29=-54 (LC 12), 30=-4 (LC 8)
Max Grav	1=131 (LC 20), 16=31 (LC 22), 17=127 (LC 24), 18=176 (LC 2), 19=203 (LC 26), 20=198 (LC 2), 21=207 (LC 26), 23=222 (LC 22), 24=208 (LC 19), 25=198 (LC 2), 26=201 (LC 25), 27=183 (LC 25), 28=101 (LC 1), 29=304 (LC 23), 30=131 (LC 20)

FORCES	(lb) - Maximum Compression/Maximum Tension
--------	--

TOP CHORD	
	1-2=-116/91, 2-3=-98/88, 3-4=-82/116, 4-5=-73/156, 5-7=-76/192, 7-8=-89/231, 8-9=-103/265, 9-10=-103/256, 10-11=-89/198, 11-12=-76/143, 12-13=-63/106, 13-14=-49/68, 14-15=-35/35, 15-16=-26/16
BOT CHORD	
	1-29=-30/47, 28-29=-30/39, 27-28=-30/39, 26-27=-30/39, 25-26=-30/39, 24-25=-30/39, 23-24=-30/39, 21-23=-30/39, 20-21=-30/39, 19-20=-30/39, 18-19=-30/39, 17-18=-30/39, 16-17=-30/39
WEBS	
	9-23=-162/22, 8-24=-129/109, 7-25=-119/98, 5-26=-119/58, 4-27=-127/64, 3-28=-88/48, 2-29=-202/160, 10-21=-129/107, 11-20=-119/99, 12-19=-119/75, 13-18=-125/114, 14-17=-95/98

- NOTES**
- Unbalanced roof live loads have been considered for this design.
 - Wind: ASCE 7-10; Vult=115mph (3-second gust) Vasd=91mph; TCCL=6.0psf; BCDL=6.0psf; h=30ft; Cat. II; Exp B; Enclosed; MWFRS (envelope) exterior zone and C-C Corner (3) 0-0-0 to 4-6-6, Exterior (2) 4-6-6 to 15-8-12, Corner (3) 15-8-12 to 20-3-2, Exterior (2) 20-3-2 to 26-6-12 zone; cantilever left and right exposed; end vertical left and right exposed; C-C for members and forces & MWFRS for reactions shown; Lumber DOL=1.60 plate grip DOL=1.60
 - Truss designed for wind loads in the plane of the truss only. For studs exposed to wind (normal to the face), see Standard Industry Gable End Details as applicable, or consult qualified building designer as per ANSI/TPI 1.
 - All plates are 1.5x4 MT20 unless otherwise indicated.
 - Gable requires continuous bottom chord bearing.
 - Gable studs spaced at 2-0-0 oc.
 - This truss has been designed for a 10.0 psf bottom chord live load nonconcurrent with any other live loads.

- * This truss has been designed for a live load of 20.0psf on the bottom chord in all areas where a rectangle 3-06-00 tall by 1-00-00 wide will fit between the bottom chord and any other members, with BCDL = 10.0psf.
 - Provide mechanical connection (by others) of truss to bearing plate capable of withstanding 4 lb uplift at joint 1, 3 lb uplift at joint 16, 27 lb uplift at joint 24, 29 lb uplift at joint 25, 27 lb uplift at joint 26, 30 lb uplift at joint 27, 17 lb uplift at joint 28, 54 lb uplift at joint 29, 25 lb uplift at joint 21, 29 lb uplift at joint 20, 27 lb uplift at joint 19, 28 lb uplift at joint 18, 38 lb uplift at joint 17 and 4 lb uplift at joint 1.
 - This truss is designed in accordance with the 2015 International Residential Code sections R502.11.1 and R802.10.2 and referenced standard ANSI/TPI 1.
- LOAD CASE(S)** Standard

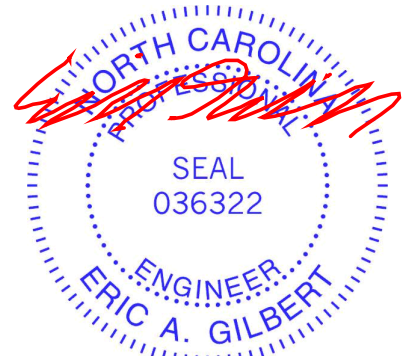

January 17, 2023

WARNING - Verify design parameters and READ NOTES ON THIS AND INCLUDED MITEK REFERENCE PAGE MII-7473 rev. 5/19/2020 BEFORE USE.

Design valid for use only with MiTek® connectors. This design is based only upon parameters shown, and is for an individual building component, not a truss system. Before use, the building designer must verify the applicability of design parameters and properly incorporate this design into the overall building design. Bracing indicated is to prevent buckling of individual truss web and/or chord members only. Additional temporary and permanent bracing is always required for stability and to prevent collapse with possible personal injury and property damage. For general guidance regarding the fabrication, storage, delivery, erection and bracing of trusses and truss systems, see ANSITPI Quality Criteria, DSB-89 and BCSI Building Component Safety Information available from Truss Plate Institute, 2670 Crain Highway, Suite 203 Waldorf, MD 20601



818 Soundside Road
Edenton, NC 27932

Job 36029A	Truss A2	Truss Type Common	Qty 6	Ply 1	57 SERENITY Job Reference (optional)	156131949
---------------	-------------	----------------------	----------	----------	---	-----------

84 Components (Dunn), Dunn, NC - 28334,

Run: 8.63 S Nov 19 2022 Print: 8.630 S Nov 19 2022 MiTek Industries, Inc. Fri Jan 13 10:16:51
ID:oXxNBfDQ9njTGcUVgqItPy6NPW-RFC?PsB70Hq3NSgPqnL8w3uITXbGKWrcDoi7J4zJC?#

Page: 1

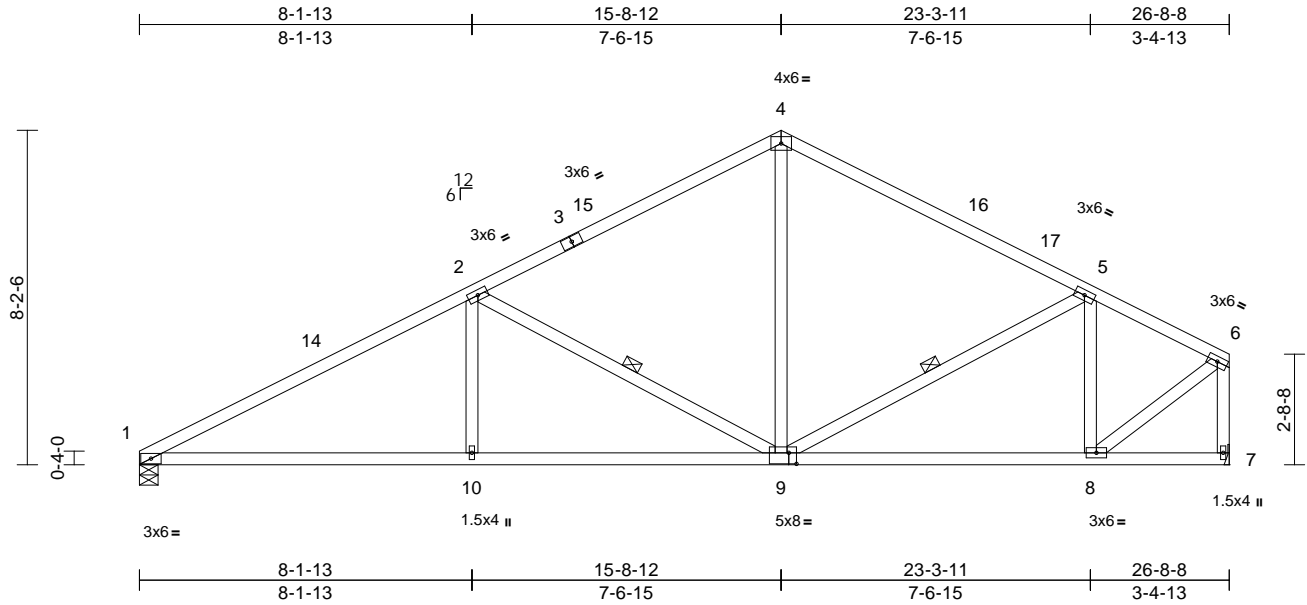

Loading	(psf)	Spacing	2-0-0	CSI	DEFL	in	(loc)	l/defl	L/d	PLATES	GRIP	
TCLL (roof)	20.0	Plate Grip DOL	1.15	TC	0.86	Vert(LL)	-0.13	10-13	>999	240	MT20	244/190
TCDL	10.0	Lumber DOL	1.15	BC	0.88	Vert(CT)	-0.30	10-13	>999	180		
BCLL	0.0*	Rep Stress Incr	YES	WB	0.43	Horz(CT)	0.05	7	n/a	n/a		
BCDL	10.0	Code	IRC2015/TPI2014	Matrix-MS							Weight: 141 lb	FT = 20%

LUMBER
TOP CHORD 2x4 SP No.2
BOT CHORD 2x4 SP No.2
WEBS 2x4 SP No.3 *Except* 9-4,9-5,9-2:2x4 SP No.2

BRACING
TOP CHORD Structural wood sheathing directly applied or 2-4-4 oc purlins, except end verticals.
BOT CHORD Rigid ceiling directly applied or 10-0-0 oc bracing, Except:
6-0-0 oc bracing: 7-8.

REACTIONS (size) 1=0-5-8, 7= Mechanical
Max Horiz 1=128 (LC 11)
Max Uplift 1=-38 (LC 12), 7=-11 (LC 13)
Max Grav 1=1062 (LC 1), 7=1063 (LC 1)

FORCES (lb) - Maximum Compression/Maximum Tension
TOP CHORD 1-2=-1842/98, 2-4=-1115/125, 4-5=-1108/120, 5-6=-919/68, 6-7=-1051/70
BOT CHORD 1-10=-100/1592, 8-10=-100/1592, 7-8=-31/35
WEBS 4-9=0/544, 5-9=-51/180, 5-8=-500/112, 2-9=-806/152, 2-10=0/339, 6-8=-56/1037

- 4) * This truss has been designed for a live load of 20.0psf on the bottom chord in all areas where a rectangle 3-06-00 tall by 1-00-00 wide will fit between the bottom chord and any other members.
 - 5) Refer to girder(s) for truss to truss connections.
 - 6) Provide mechanical connection (by others) of truss to bearing plate capable of withstanding 38 lb uplift at joint 1 and 11 lb uplift at joint 7.
 - 7) This truss is designed in accordance with the 2015 International Residential Code sections R502.11.1 and R802.10.2 and referenced standard ANSI/TPI 1.
- LOAD CASE(S)** Standard

- NOTES**
- 1) Unbalanced roof live loads have been considered for this design.
 - 2) Wind: ASCE 7-10; Vult=115mph (3-second gust) Vasd=91mph; TCCL=6.0psf; BCCL=6.0psf; h=30ft; Cat. II; Exp B; Enclosed; MWFRS (envelope) exterior zone and C-C Exterior (2) 0-0-0 to 4-6-6, Interior (1) 4-6-6 to 15-8-12, Exterior (2) 15-8-12 to 20-3-2, Interior (1) 20-3-2 to 26-6-12 zone; cantilever left and right exposed; end vertical left and right exposed; C-C for members and forces & MWFRS for reactions shown; Lumber DOL=1.60 plate grip DOL=1.60
 - 3) This truss has been designed for a 10.0 psf bottom chord live load nonconcurrent with any other live loads.



January 17, 2023

Job 36029A	Truss A2A	Truss Type Attic	Qty 2	Ply 1	57 SERENITY Job Reference (optional)	156131950
---------------	--------------	---------------------	----------	----------	---	-----------

84 Components (Dunn), Dunn, NC - 28334,

Run: 8.63 S Nov 19 2022 Print: 8.630 S Nov 19 2022 MiTek Industries, Inc. Fri Jan 13 10:16:51
ID:oXxNXBfDQ9njTgcUVgqItPy6NPW-RfC?PsB70Hq3NSgPqnL8w3ulTXbGKWRcDoi7J4zJC?f

Page: 1

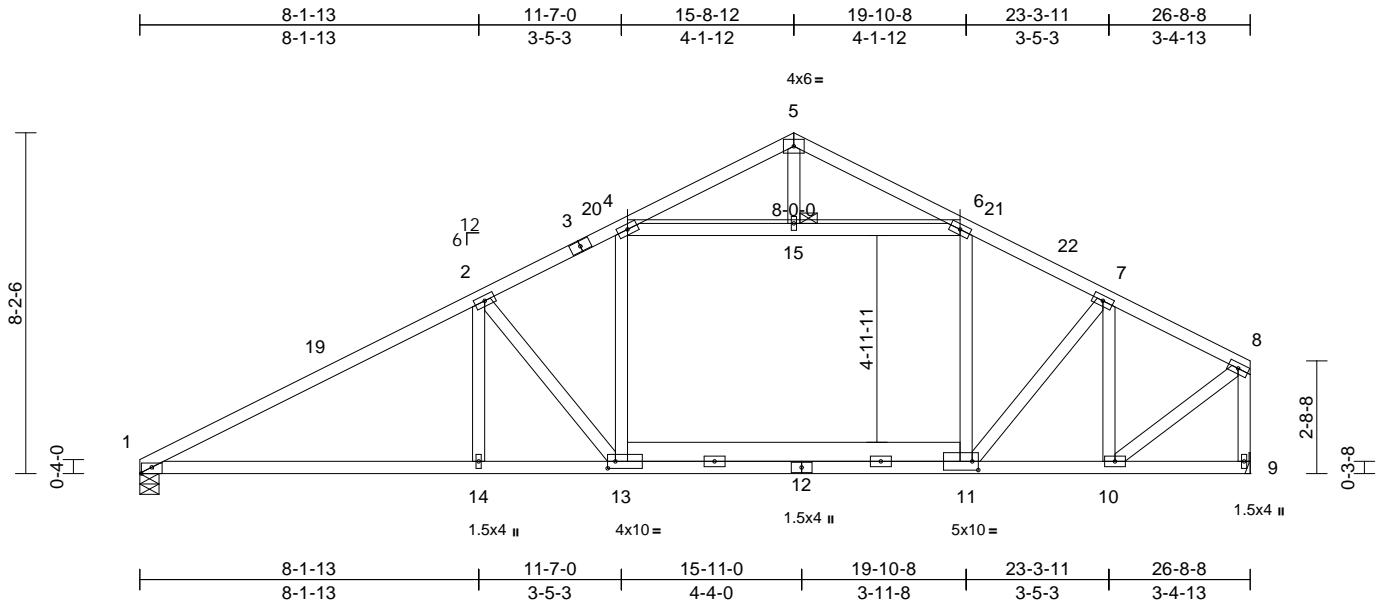

Scale = 1:55.4

Plate Offsets (X, Y): [1:0-3-0,Edge], [11:0-1-12,0-2-8], [13:0-2-4,0-2-0]

Loading	(psf)	Spacing	2-0-0	CSI	DEFL	in	(loc)	l/defl	L/d	PLATES	GRIP	
TCLL (roof)	20.0	Plate Grip DOL	1.15	TC	0.76	Vert(LL)	-0.39	13-14	>822	240	MT20	244/190
TCDL	10.0	Lumber DOL	1.15	BC	0.91	Vert(CT)	-0.65	13-14	>489	180		
BCLL	0.0*	Rep Stress Incr	YES	WB	0.50	Horz(CT)	0.03	9	n/a	n/a		
BCDL	10.0	Code	IRC2015/TPI2014	Matrix-MS							Weight: 170 lb	FT = 20%

LUMBER
TOP CHORD 2x4 SP No.2
BOT CHORD 2x4 SP DSS *Except* 13-11:2x6 SP No.2
WEBS 2x4 SP No.3 *Except* 4-6:2x4 SP No.2

BRACING
TOP CHORD Structural wood sheathing directly applied or 2-2-0 oc purlins, except end verticals.
BOT CHORD Rigid ceiling directly applied or 5-8-6 oc bracing.

JOINTS
1 Brace at Jt(s): 15

REACTIONS (size) 1=0-5-8, 9= Mechanical
Max Horiz 1=128 (LC 11)
Max Uplift 1=-38 (LC 12), 9=-11 (LC 13)
Max Grav 1=1063 (LC 1), 9=1077 (LC 2)

FORCES (lb) - Maximum Compression/Maximum Tension
TOP CHORD 1-2=-1879/100, 2-4=-1359/127, 4-5=-342/96, 5-6=-398/97, 6-7=-1267/112, 7-8=-850/68, 8-9=-981/77
BOT CHORD 1-14=-100/1604, 13-14=-100/1604, 11-13=-50/1134, 10-11=-54/722, 9-10=-21/41
WEBS 7-11=-60/675, 7-10=-775/83, 2-13=-896/166, 2-14=0/471, 8-10=-41/870, 4-13=0/443, 6-11=0/202, 4-15=-882/65, 6-15=-882/65, 5-15=-3/41

- This truss has been designed for a 10.0 psf bottom chord live load nonconcurrent with any other live loads.
 - * This truss has been designed for a live load of 20.0psf on the bottom chord in all areas where a rectangle 3-06-00 tall by 1-00-00 wide will fit between the bottom chord and any other members, with BCDL = 10.0psf.
 - Refer to girder(s) for truss to truss connections.
 - Provide mechanical connection (by others) of truss to bearing plate capable of withstanding 38 lb uplift at joint 1 and 11 lb uplift at joint 9.
 - This truss is designed in accordance with the 2015 International Residential Code sections R502.11.1 and R802.10.2 and referenced standard ANSI/TPI 1.
- LOAD CASE(S)** Standard

- NOTES**
- Unbalanced roof live loads have been considered for this design.
 - Wind: ASCE 7-10; Vult=115mph (3-second gust) Vasd=91mph; TCCL=6.0psf; BCDL=6.0psf; h=30ft; Cat. II; Exp B; Enclosed; MWFRS (envelope) exterior zone and C-C Exterior (2) 0-0-0 to 4-6-6, Interior (1) 4-6-6 to 15-8-12, Exterior (2) 15-8-12 to 20-3-2, Interior (1) 20-3-2 to 26-6-12 zone; cantilever left and right exposed ; end vertical left and right exposed;C-C for members and forces & MWFRS for reactions shown; Lumber DOL=1.60 plate grip DOL=1.60
 - All plates are 3x6 MT20 unless otherwise indicated.

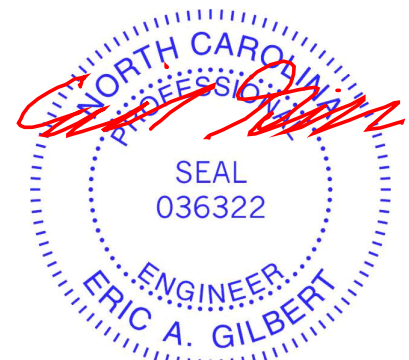

January 17, 2023

WARNING - Verify design parameters and READ NOTES ON THIS AND INCLUDED MITEK REFERENCE PAGE MII-7473 rev. 5/19/2020 BEFORE USE.

Design valid for use only with MiTek® connectors. This design is based only upon parameters shown, and is for an individual building component, not a truss system. Before use, the building designer must verify the applicability of design parameters and properly incorporate this design into the overall building design. Bracing indicated is to prevent buckling of individual truss web and/or chord members only. Additional temporary and permanent bracing is always required for stability and to prevent collapse with possible personal injury and property damage. For general guidance regarding the fabrication, storage, delivery, erection and bracing of trusses and truss systems, see **ANSI/TPI1 Quality Criteria, DSB-89 and BCSI Building Component Safety Information** available from Truss Plate Institute, 2670 Crain Highway, Suite 203 Waldorf, MD 20601



818 Soundside Road
Edenton, NC 27932

Job 36029A	Truss A3A	Truss Type Attic	Qty 1	Ply 1	57 SERENITY Job Reference (optional)	156131951
---------------	--------------	---------------------	----------	----------	---	-----------

84 Components (Dunn), Dunn, NC - 28334,

Run: 8.63 S Nov 19 2022 Print: 8.630 S Nov 19 2022 MiTek Industries, Inc. Fri Jan 13 10:16:52
ID:zB9O_aCSqzSKNAY7ed8lCvy6NOp-RfC?PsB70Hq3NSgPqnL8w3uTXbGKwRCDoi7J4zJC7f

Page: 1

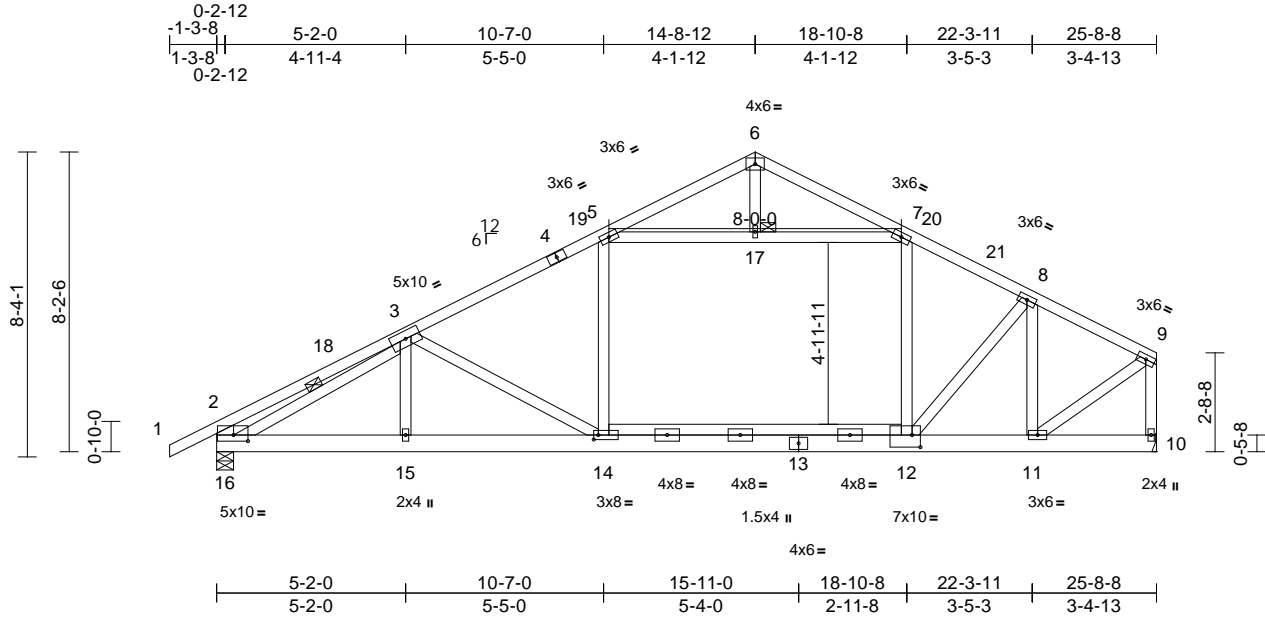

Scale = 1:63

Plate Offsets (X, Y): [12:0-2-12,0-4-0], [14:0-1-8,0-1-8], [16:0-4-12,0-2-0]

Loading	(psf)	Spacing	2-0-0	CSI	DEFL	in	(loc)	l/defl	L/d	PLATES	GRIP	
TCLL (roof)	20.0	Plate Grip DOL	1.15	TC	0.39	Vert(LL)	-0.20	14-15	>999	240	MT20	244/190
TCDL	10.0	Lumber DOL	1.15	BC	0.90	Vert(CT)	-0.36	14-15	>833	180		
BCLL	0.0*	Rep Stress Incr	YES	WB	0.49	Horz(CT)	0.03	10	n/a	n/a		
BCDL	10.0	Code	IRC2015/TPI2014	Matrix-MS		Attic	-0.14	12-14	>737	360	Weight: 190 lb	FT = 20%

LUMBER

TOP CHORD 2x4 SP No.2
 BOT CHORD 2x6 SP No.2 *Except* 13-10:2x6 SP DSS, 14-12:2x4 SP No.2
 WEBS 2x4 SP No.3 *Except* 5-7:2x4 SP No.2, 16-2:2x6 SP No.2

BRACING

TOP CHORD Structural wood sheathing directly applied or 4-0-4 oc purlins, except end verticals.
 BOT CHORD Rigid ceiling directly applied or 9-1-6 oc bracing.
 WEBS 1 Row at midpt 3-16
 JOINTS 1 Brace at Jt(s): 17

REACTIONS

(size) 10= Mechanical, 16=0-5-8
 Max Horiz 16=131 (LC 11)
 Max Grav 10=1330 (LC 2), 16=1298 (LC 2)

FORCES

(lb) - Maximum Compression/Maximum Tension
 TOP CHORD 1-2=0/41, 2-3=-59/104, 3-5=-1742/0, 5-6=-402/48, 6-7=-416/47, 7-8=-1692/0, 8-9=-1071/0, 9-10=-1206/0
 BOT CHORD 15-16=0/1771, 14-15=0/1770, 12-14=0/1496, 11-12=0/923, 10-11=-21/39
 WEBS 3-14=-497/143, 3-15=0/306, 9-11=0/1110, 5-14=0/416, 7-12=0/366, 5-17=-1208/0, 7-17=-1208/0, 6-17=0/108, 8-11=-1079/0, 8-12=0/933, 2-16=-223/156, 3-16=-2060/0

NOTES

1) Unbalanced roof live loads have been considered for this design.

- Wind: ASCE 7-10; Vult=115mph (3-second gust) Vasd=91mph; TC DL=6.0psf; BCDL=6.0psf; h=30ft; Cat. II; Exp B; Enclosed; MWFRS (envelope) exterior zone and C-C Exterior (2) -0-3-8 to 4-2-14, Interior (1) 4-2-14 to 15-8-12, Exterior (2) 15-8-12 to 20-3-2, Interior (1) 20-3-2 to 26-6-12 zone; cantilever left and right exposed; end vertical left and right exposed; C-C for members and forces & MWFRS for reactions shown; Lumber DOL=1.60 plate grip DOL=1.60
- This truss has been designed for a 10.0 psf bottom chord live load nonconcurrent with any other live loads.
- * This truss has been designed for a live load of 20.0psf on the bottom chord in all areas where a rectangle 3-06-00 tall by 1-00-00 wide will fit between the bottom chord and any other members.
- Ceiling dead load (5.0 psf) on member(s). 5-17, 7-17; Wall dead load (5.0psf) on member(s). 5-14, 7-12
- Bottom chord live load (40.0 psf) and additional bottom chord dead load (5.0 psf) applied only to room. 12-14
- Refer to girder(s) for truss connections.
- This truss is designed in accordance with the 2015 International Residential Code sections R502.11.1 and R802.10.2 and referenced standard ANSI/TPI 1.
- ATTIC SPACE SHOWN IS DESIGNED AS UNINHABITABLE.

LOAD CASE(S) Standard

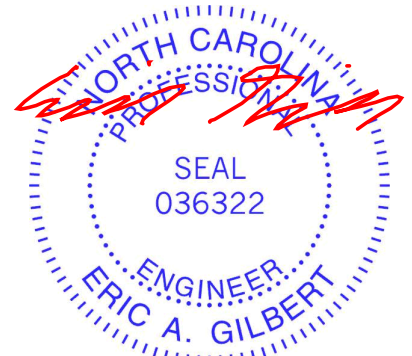

January 17, 2023

WARNING - Verify design parameters and READ NOTES ON THIS AND INCLUDED MITEK REFERENCE PAGE MII-7473 rev. 5/19/2020 BEFORE USE.

Design valid for use only with MiTek® connectors. This design is based only upon parameters shown, and is for an individual building component, not a truss system. Before use, the building designer must verify the applicability of design parameters and properly incorporate this design into the overall building design. Bracing indicated is to prevent buckling of individual truss web and/or chord members only. Additional temporary and permanent bracing is always required for stability and to prevent collapse with possible personal injury and property damage. For general guidance regarding the fabrication, storage, delivery, erection and bracing of trusses and truss systems, see ANSI/TPI1 Quality Criteria, DSB-89 and BCSI Building Component Safety Information available from Truss Plate Institute, 2670 Crain Highway, Suite 203 Waldorf, MD 20601



818 Soundside Road
 Edenton, NC 27932

Job 36029A	Truss A5E	Truss Type Common Supported Gable	Qty 1	Ply 1	57 SERENITY Job Reference (optional)	I56131953
---------------	--------------	--------------------------------------	----------	----------	---	-----------

84 Components (Dunn), Dunn, NC - 28334,

Run: 8.63 S Nov 19 2022 Print: 8.630 S Nov 19 2022 MiTek Industries, Inc. Fri Jan 13 10:16:53
ID:lztqZH8p98cdZmmt0D?Phey6NMJ-RfC?PsB70Hq3NSgPqnL8w3uTXbGKWrCDoi7J4zJC?F

Page: 1

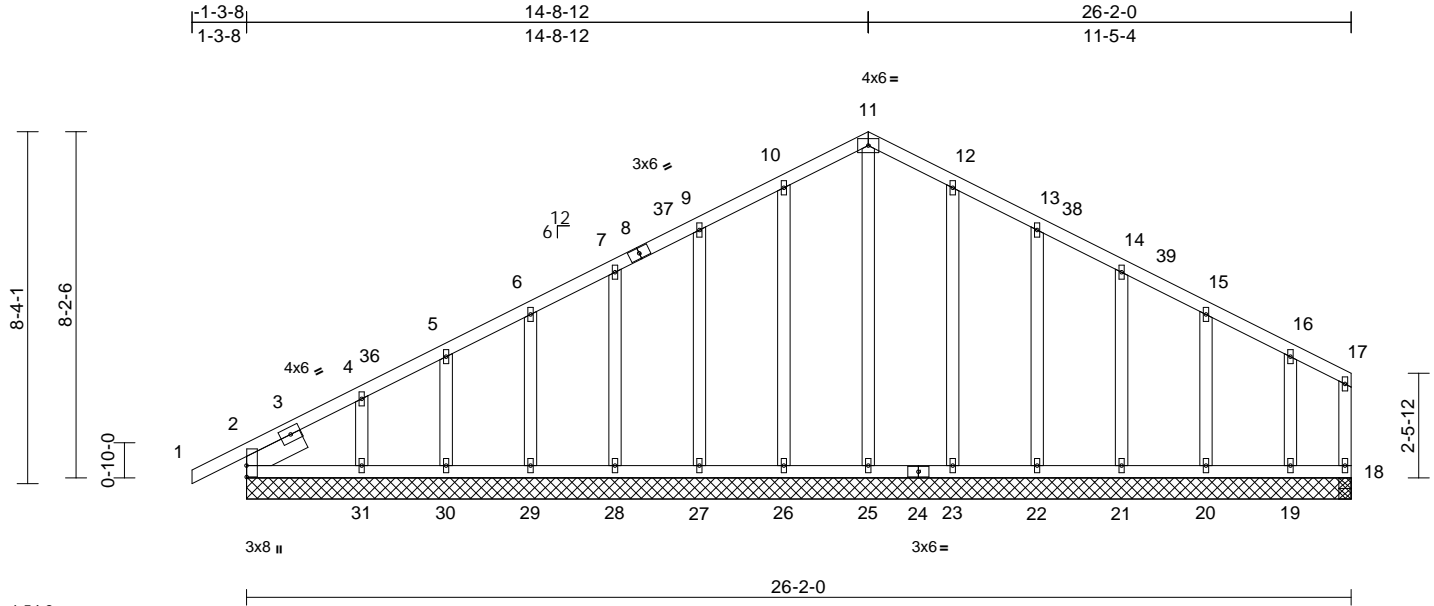

Scale = 1:54.6

Plate Offsets (X, Y): [2:0-3-4,0-0-1]

Loading	(psf)	Spacing	2-0-0	CSI	DEFL	in (loc)	l/defl	L/d	PLATES	GRIP
TCLL (roof)	20.0	Plate Grip DOL	1.15	TC	0.11	Vert(LL)	0.00	31-34	>999	240
TCDL	10.0	Lumber DOL	1.15	BC	0.04	Vert(CT)	0.00	31-34	>999	180
BCLL	0.0*	Rep Stress Incr	YES	WB	0.18	Horz(CT)	0.00	2	n/a	n/a
BCDL	10.0	Code	IRC2015/TPI2014	Matrix-MS						
										Weight: 174 lb FT = 20%

LUMBER		
TOP CHORD	2x4 SP No.2	
BOT CHORD	2x4 SP No.2	
WEBS	2x4 SP No.3	
OTHERS	2x4 SP No.3 *Except* 25-11,26-10,23-12:2x4 SP No.2	
SLIDER	Left 2x6 SP No.2 -- 1-6-0	

BRACING		
TOP CHORD	Structural wood sheathing directly applied or 6-0-0 oc purlins, except end verticals.	
BOT CHORD	Rigid ceiling directly applied or 10-0-0 oc bracing.	

REACTIONS	(size)	
Max Horiz	2=26-2-0, 18=26-2-0, 19=26-2-0, 20=26-2-0, 21=26-2-0, 22=26-2-0, 23=26-2-0, 25=26-2-0, 26=26-2-0, 27=26-2-0, 28=26-2-0, 29=26-2-0, 30=26-2-0, 31=26-2-0, 32=26-2-0	
Max Uplift	2=127 (LC 11), 32=127 (LC 11)	
Max Grav	2=192 (LC 1), 18=45 (LC 22), 19=140 (LC 24), 20=174 (LC 2), 21=203 (LC 26), 22=198 (LC 2), 23=207 (LC 26), 25=231 (LC 22), 26=208 (LC 19), 27=198 (LC 2), 28=204 (LC 25), 29=173 (LC 19), 30=149 (LC 1), 31=195 (LC 23), 32=192 (LC 1)	

FORCES	(lb) - Maximum Compression/Maximum Tension	
--------	--	--

TOP CHORD	
1-2=0/35, 2-4=-107/81, 4-5=-89/87, 5-6=-82/122, 6-7=-70/160, 7-9=-77/197, 9-10=-91/236, 10-11=-104/270, 11-12=-104/261, 12-13=-91/203, 13-14=-77/150, 14-15=-65/111, 15-16=-51/73, 16-17=-36/38, 17-18=-35/23	
BOT CHORD	
2-31=-26/37, 30-31=-26/37, 29-30=-26/37, 28-29=-26/37, 27-28=-26/37, 26-27=-26/37, 25-26=-26/37, 23-25=-26/37, 22-23=-26/37, 21-22=-26/37, 20-21=-26/37, 19-20=-26/37, 18-19=-26/37	
WEBS	
11-25=-166/23, 10-26=-129/108, 9-27=-118/98, 7-28=-120/58, 6-29=-121/61, 5-30=-115/54, 4-31=-137/109, 12-23=-129/107, 13-22=-119/99, 14-21=-120/67, 15-20=-123/108, 16-19=-106/105	

- NOTES**
- Unbalanced roof live loads have been considered for this design.
 - Wind: ASCE 7-10; Vult=115mph (3-second gust) Vasd=91mph; TCCL=6.0psf; BCDL=6.0psf; h=30ft; Cat. II; Exp B; Enclosed; MWFRS (envelope) exterior zone and C-C Corner (3) -1-3-8 to 3-2-14, Exterior (2) 3-2-14 to 14-8-12, Corner (3) 14-8-12 to 19-3-2, Exterior (2) 19-3-2 to 26-0-4 zone; cantilever left and right exposed; end vertical left and right exposed; C-C for members and forces & MWFRS for reactions shown; Lumber DOL=1.60 plate grip DOL=1.60
 - Truss designed for wind loads in the plane of the truss only. For studs exposed to wind (normal to the face), see Standard Industry Gable End Details as applicable, or consult qualified building designer as per ANSI/TPI 1.
 - All plates are 1.5x4 MT20 unless otherwise indicated.
 - Gable studs spaced at 2-0-0 oc.
 - This truss has been designed for a 10.0 psf bottom chord live load nonconcurrent with any other live loads.

- * This truss has been designed for a live load of 20.0psf on the bottom chord in all areas where a rectangle 3-06-00 tall by 1-00-00 wide will fit between the bottom chord and any other members, with BCDL = 10.0psf.
 - Provide mechanical connection (by others) of truss to bearing plate capable of withstanding 34 lb uplift at joint 2, 6 lb uplift at joint 18, 27 lb uplift at joint 26, 29 lb uplift at joint 27, 27 lb uplift at joint 28, 31 lb uplift at joint 29, 14 lb uplift at joint 30, 70 lb uplift at joint 31, 25 lb uplift at joint 23, 30 lb uplift at joint 22, 28 lb uplift at joint 21, 27 lb uplift at joint 20, 39 lb uplift at joint 19 and 34 lb uplift at joint 2.
 - This truss is designed in accordance with the 2015 International Residential Code sections R502.11.1 and R802.10.2 and referenced standard ANSI/TPI 1.
- LOAD CASE(S)** Standard

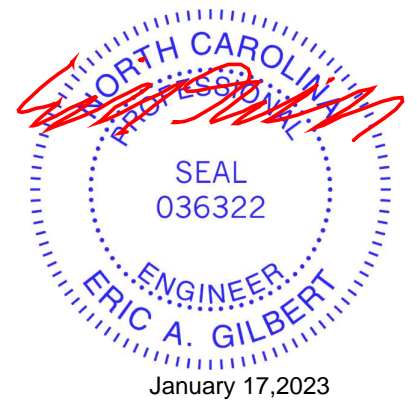

Job 36029A	Truss B1E	Truss Type Common Supported Gable	Qty 1	Ply 1	57 SERENITY Job Reference (optional)	I56131954
---------------	--------------	--------------------------------------	----------	----------	---	-----------

84 Components (Dunn), Dunn, NC - 28334,

Run: 8.63 S Nov 19 2022 Print: 8.630 S Nov 19 2022 MiTek Industries, Inc. Fri Jan 13 10:16:54
ID:uCk0ehjwrfufK8S6qJt4dmy6NLZ-RFC?PsB70Hq3NSgPqnL8w3uITXbGKWrcDoi7J4zJC?f

Page: 1

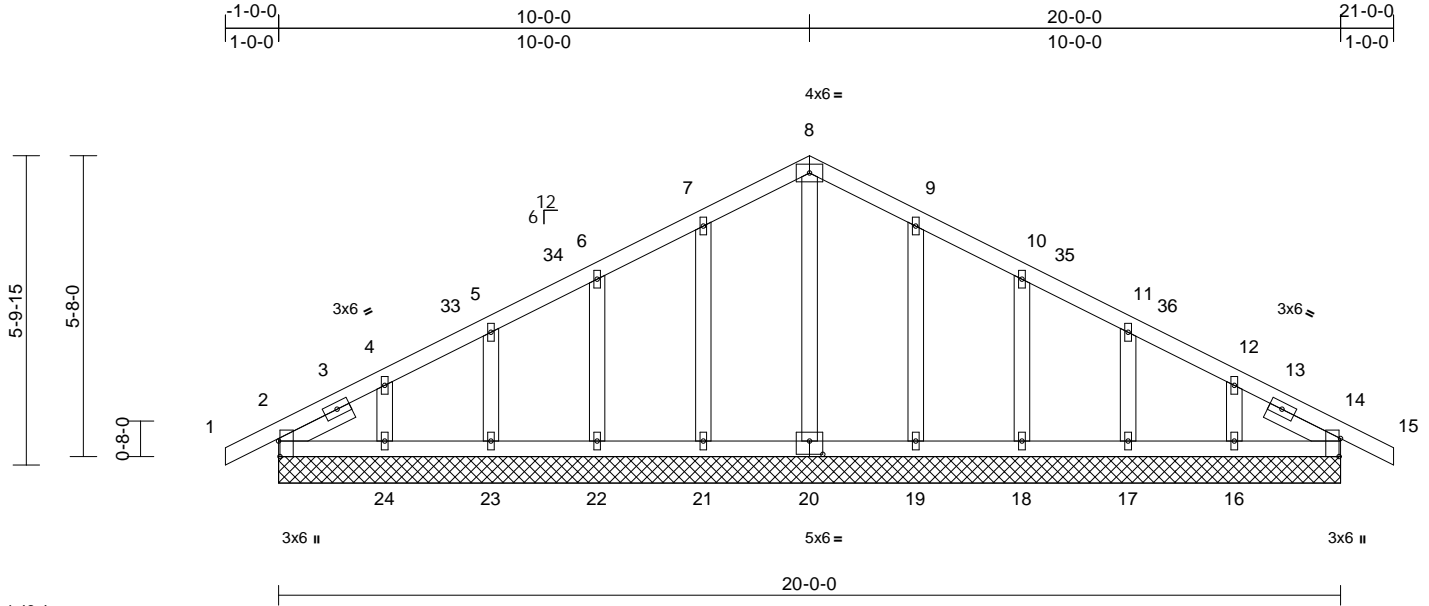

Scale = 1:43.4

Plate Offsets (X, Y): [2:0-3-8,Edge], [14:0-4-1,Edge], [20:0-3-0,0-3-0]

Loading	(psf)	Spacing	2-0-0	CSI	DEFL	in	(loc)	l/defl	L/d	PLATES	GRIP	
TCLL (roof)	20.0	Plate Grip DOL	1.15	TC	0.07	Vert(LL)	n/a	-	n/a	999	MT20	244/190
TCDL	10.0	Lumber DOL	1.15	BC	0.05	Vert(CT)	n/a	-	n/a	999		
BCLL	0.0*	Rep Stress Incr	YES	WB	0.06	Horz(CT)	0.00	14	n/a	n/a		
BCDL	10.0	Code	IRC2015/TPI2014	Matrix-MS							Weight: 110 lb	FT = 20%

LUMBER
TOP CHORD 2x4 SP No.2
BOT CHORD 2x4 SP No.2
OTHERS 2x4 SP No.3
SLIDER Left 2x4 SP No.3 -- 1-6-0, Right 2x4 SP No.3 -- 1-6-0

WEBS
8-20=-104/0, 7-21=-129/112, 6-22=-118/97,
5-23=-122/73, 4-24=-112/108,
9-19=-129/112, 10-18=-118/97,
11-17=-122/73, 12-16=-112/108

BRACING
TOP CHORD Structural wood sheathing directly applied or 6-0-0 oc purlins.
BOT CHORD Rigid ceiling directly applied or 10-0-0 oc bracing.

REACTIONS (size)
2=20-0-0, 14=20-0-0, 16=20-0-0, 17=20-0-0, 18=20-0-0, 19=20-0-0, 20=20-0-0, 21=20-0-0, 22=20-0-0, 23=20-0-0, 24=20-0-0, 25=20-0-0, 29=20-0-0
Max Horiz 2=72 (LC 12), 25=72 (LC 12)
Max Uplift 2=-7 (LC 13), 16=-41 (LC 13), 17=-25 (LC 13), 18=-29 (LC 13), 19=-28 (LC 13), 21=-29 (LC 12), 22=-29 (LC 12), 23=-24 (LC 12), 24=-47 (LC 12), 25=-7 (LC 13)
Max Grav 2=152 (LC 1), 14=152 (LC 1), 16=155 (LC 24), 17=161 (LC 1), 18=158 (LC 1), 19=176 (LC 26), 20=212 (LC 22), 21=176 (LC 25), 22=158 (LC 1), 23=161 (LC 1), 24=155 (LC 23), 25=152 (LC 1), 29=152 (LC 1)

FORCES (lb) - Maximum Compression/Maximum Tension
TOP CHORD 1-2=0/27, 2-4=-75/40, 4-5=-61/47, 5-6=-48/81, 6-7=-44/118, 7-8=-58/155, 8-9=-58/157, 9-10=-44/121, 10-11=-43/84, 11-12=-42/40, 12-14=-50/17, 14-15=0/27
BOT CHORD 2-24=-13/78, 23-24=-13/78, 22-23=-13/78, 21-22=-13/78, 19-21=-13/78, 18-19=-13/78, 17-18=-13/78, 16-17=-13/78, 14-16=-13/78

- NOTES**
- 1) Unbalanced roof live loads have been considered for this design.
 - 2) Wind: ASCE 7-10; Vult=115mph (3-second gust) Vasd=91mph; TCCL=6.0psf; BCDL=6.0psf; h=30ft; Cat. II; Exp B; Enclosed; MWFRS (envelope) exterior zone and C-C Corner (3) -1-0-0 to 3-6-6, Exterior (2) 3-6-6 to 10-0-0, Corner (3) 10-0-0 to 14-6-6, Exterior (2) 14-6-6 to 21-0-0 zone; cantilever left and right exposed ; end vertical left and right exposed;C-C for members and forces & MWFRS for reactions shown; Lumber DOL=1.60 plate grip DOL=1.60
 - 3) Truss designed for wind loads in the plane of the truss only. For studs exposed to wind (normal to the face), see Standard Industry Gable End Details as applicable, or consult qualified building designer as per ANSI/TPI 1.
 - 4) All plates are 1.5x4 MT20 unless otherwise indicated.
 - 5) Gable requires continuous bottom chord bearing.
 - 6) Gable studs spaced at 2-0-0 oc.
 - 7) This truss has been designed for a 10.0 psf bottom chord live load nonconcurrent with any other live loads.
 - 8) * This truss has been designed for a live load of 20.0psf on the bottom chord in all areas where a rectangle 3-06-00 tall by 1-00-00 wide will fit between the bottom chord and any other members, with BCDL = 10.0psf.
 - 9) Provide mechanical connection (by others) of truss to bearing plate capable of withstanding 7 lb uplift at joint 2, 29 lb uplift at joint 21, 29 lb uplift at joint 22, 24 lb uplift at joint 23, 47 lb uplift at joint 24, 28 lb uplift at joint 19, 29 lb uplift at joint 18, 25 lb uplift at joint 17, 41 lb uplift at joint 16 and 7 lb uplift at joint 2.
 - 10) This truss is designed in accordance with the 2015 International Residential Code sections R502.11.1 and R802.10.2 and referenced standard ANSI/TPI 1.

LOAD CASE(S) Standard



January 17, 2023

WARNING - Verify design parameters and READ NOTES ON THIS AND INCLUDED MITEK REFERENCE PAGE MII-7473 rev. 5/19/2020 BEFORE USE.

Design valid for use only with MiTek® connectors. This design is based only upon parameters shown, and is for an individual building component, not a truss system. Before use, the building designer must verify the applicability of design parameters and properly incorporate this design into the overall building design. Bracing indicated is to prevent buckling of individual truss web and/or chord members only. Additional temporary and permanent bracing is always required for stability and to prevent collapse with possible personal injury and property damage. For general guidance regarding the fabrication, storage, delivery, erection and bracing of trusses and truss systems, see

ANSI/TPI1 Quality Criteria, DSB-89 and BCSI Building Component

Safety Information available from Truss Plate Institute, 2670 Crain Highway, Suite 203 Waldorf, MD 20601



818 Soundside Road
Edenton, NC 27932

Job 36029A	Truss B2	Truss Type Common	Qty 9	Ply 1	57 SERENITY Job Reference (optional)	156131955
---------------	-------------	----------------------	----------	----------	---	-----------

84 Components (Dunn), Dunn, NC - 28334,

Run: 8.63 S Nov 19 2022 Print: 8.630 S Nov 19 2022 MiTek Industries, Inc. Fri Jan 13 10:16:54
ID:yMf6Le6_JjhHA3uFi1RawWy6NL3-RfC?PsB70Hq3NSgPqnL8w3uITxBGKWrCdoi7J4zJC?f

Page: 1

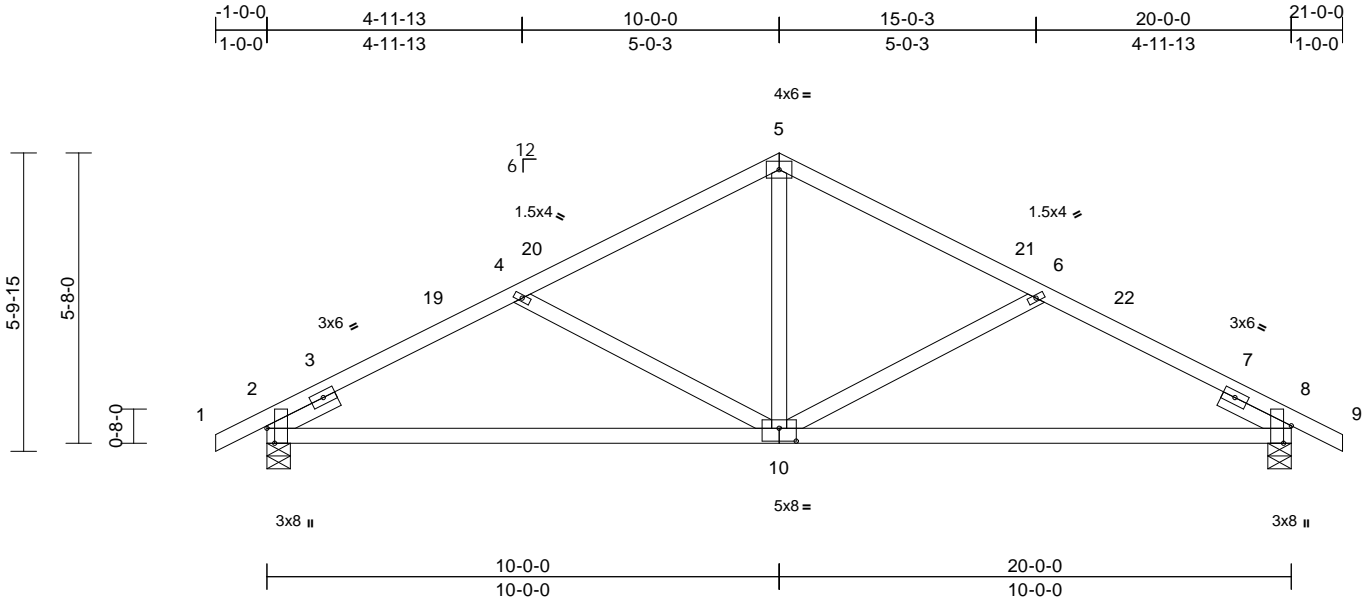

Scale = 1:45

Plate Offsets (X, Y): [2:0-3-8,Edge], [8:0-4-1,Edge], [10:0-4-0,0-3-0]

Loading	(psf)	Spacing	2-0-0	CSI	DEFL	in	(loc)	l/defl	L/d	PLATES	GRIP	
TCLL (roof)	20.0	Plate Grip DOL	1.15	TC	0.32	Vert(LL)	-0.13	10-13	>999	240	MT20	244/190
TCDL	10.0	Lumber DOL	1.15	BC	0.83	Vert(CT)	-0.26	10-13	>907	180		
BCLL	0.0*	Rep Stress Incr	YES	WB	0.22	Horz(CT)	0.03	8	n/a	n/a		
BCDL	10.0	Code	IRC2015/TPI2014	Matrix-MS							Weight: 95 lb	FT = 20%

LUMBER

- TOP CHORD 2x4 SP No.2
- BOT CHORD 2x4 SP No.2
- WEBS 2x4 SP No.3
- SLIDER Left 2x4 SP No.3 -- 1-6-0, Right 2x4 SP No.3 -- 1-6-0

BRACING

- TOP CHORD Structural wood sheathing directly applied or 5-2-0 oc purlins.
- BOT CHORD Rigid ceiling directly applied or 10-0-0 oc bracing.

REACTIONS

- (size) 2=0-5-8, 8=0-5-8
- Max Horiz 2=72 (LC 12)
- Max Uplift 2=-35 (LC 12), 8=-35 (LC 13)
- Max Grav 2=860 (LC 1), 8=860 (LC 1)

FORCES

- (lb) - Maximum Compression/Maximum Tension
- TOP CHORD 1-2=0/27, 2-4=-1225/107, 4-5=-947/84, 5-6=-947/84, 6-8=-1225/107, 8-9=0/27
- BOT CHORD 2-8=-138/1057
- WEBS 5-10=0/537, 4-10=-336/131, 6-10=-336/132

NOTES

- Unbalanced roof live loads have been considered for this design.
- Wind: ASCE 7-10; Vult=115mph (3-second gust) Vasd=91mph; TCDL=6.0psf; BCDL=6.0psf; h=30ft; Cat. II; Exp B; Enclosed; MWFRS (envelope) exterior zone and C-C Exterior (2) -1-0-0 to 3-6-6, Interior (1) 3-6-6 to 10-0-0, Exterior (2) 10-0-0 to 14-6-6, Interior (1) 14-6-6 to 21-0-0 zone; cantilever left and right exposed; end vertical left and right exposed; C-C for members and forces & MWFRS for reactions shown; Lumber DOL=1.60 plate grip DOL=1.60
- This truss has been designed for a 10.0 psf bottom chord live load nonconcurrent with any other live loads.

- * This truss has been designed for a live load of 20.0psf on the bottom chord in all areas where a rectangle 3-06-00 tall by 1-00-00 wide will fit between the bottom chord and any other members.
- Provide mechanical connection (by others) of truss to bearing plate capable of withstanding 35 lb uplift at joint 2 and 35 lb uplift at joint 8.
- This truss is designed in accordance with the 2015 International Residential Code sections R502.11.1 and R802.10.2 and referenced standard ANSI/TPI 1.

LOAD CASE(S) Standard

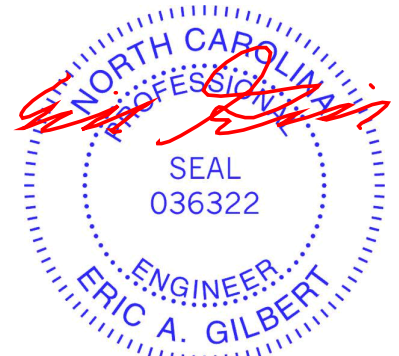

January 17, 2023

WARNING - Verify design parameters and READ NOTES ON THIS AND INCLUDED MITEK REFERENCE PAGE MII-7473 rev. 5/19/2020 BEFORE USE.

Design valid for use only with MiTek® connectors. This design is based only upon parameters shown, and is for an individual building component, not a truss system. Before use, the building designer must verify the applicability of design parameters and properly incorporate this design into the overall building design. Bracing indicated is to prevent buckling of individual truss web and/or chord members only. Additional temporary and permanent bracing is always required for stability and to prevent collapse with possible personal injury and property damage. For general guidance regarding the fabrication, storage, delivery, erection and bracing of trusses and truss systems, see **ANSI/TPI1 Quality Criteria, DSB-89 and BCSI Building Component Safety Information** available from Truss Plate Institute, 2670 Crain Highway, Suite 203 Waldorf, MD 20601



818 Soundside Road
Edenton, NC 27932

Job 36029A	Truss B3	Truss Type Common	Qty 2	Ply 1	57 SERENITY Job Reference (optional)	156131956
---------------	-------------	----------------------	----------	----------	---	-----------

84 Components (Dunn), Dunn, NC - 28334,

Run: 8.63 S Nov 19 2022 Print: 8.630 S Nov 19 2022 MiTek Industries, Inc. Fri Jan 13 10:16:54
ID:Q5HLhcXy3T5JsR4_FiZnry6NKW-RfC?PsB70Hq3NSgPqnL8w3ulTXbGKWRcDoi7J4zJC?f

Page: 1

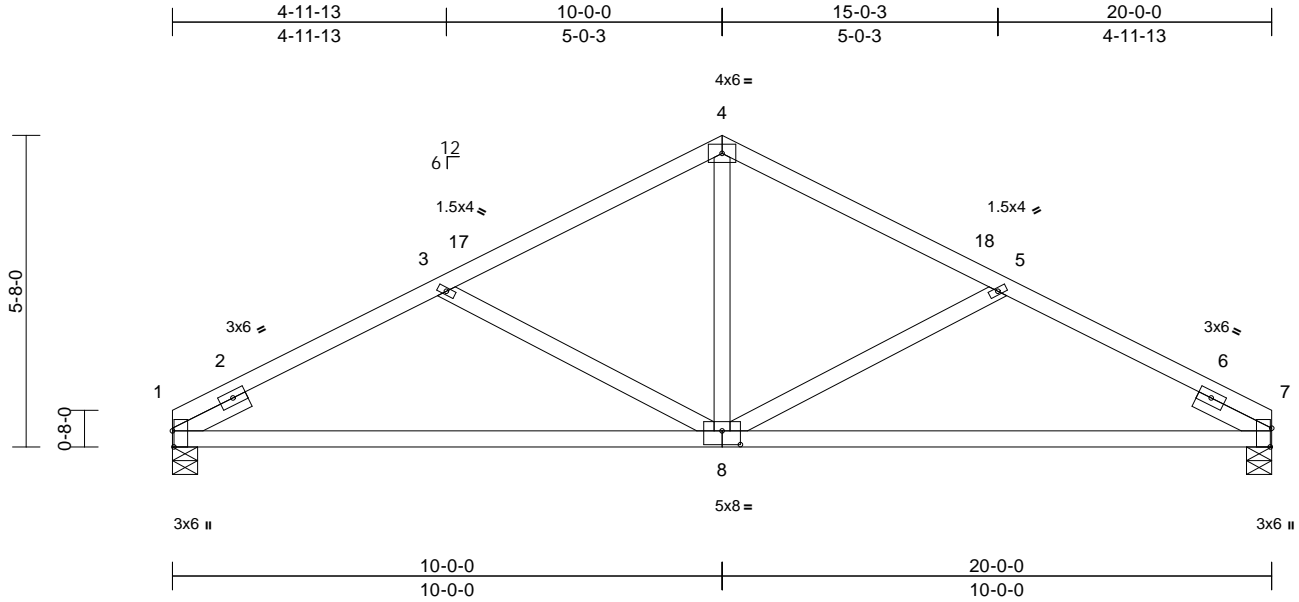

Scale = 1:41.9
Plate Offsets (X, Y): [1:0-3-8,Edge], [7:0-4-1,Edge], [8:0-4-0,0-3-0]

Loading	(psf)	Spacing	2-0-0	CSI	DEFL	in	(loc)	l/defl	L/d	PLATES	GRIP	
TCLL (roof)	20.0	Plate Grip DOL	1.15	TC	0.30	Vert(LL)	-0.13	8-11	>999	240	MT20	244/190
TCDL	10.0	Lumber DOL	1.15	BC	0.83	Vert(CT)	-0.27	8-11	>902	180		
BCLL	0.0*	Rep Stress Incr	YES	WB	0.23	Horz(CT)	0.03	7	n/a	n/a		
BCDL	10.0	Code	IRC2015/TPI2014	Matrix-MS							Weight: 92 lb	FT = 20%

LUMBER
TOP CHORD 2x4 SP No.2
BOT CHORD 2x4 SP No.2
WEBS 2x4 SP No.3
SLIDER Left 2x4 SP No.3 -- 1-6-0, Right 2x4 SP No.3 -- 1-6-0

BRACING
TOP CHORD Structural wood sheathing directly applied or 5-3-15 oc purlins.
BOT CHORD Rigid ceiling directly applied or 10-0-0 oc bracing.

REACTIONS (size) 1=0-5-8, 7=0-5-8
Max Horiz 1=65 (LC 12)
Max Uplift 1=-20 (LC 12), 7=-20 (LC 13)
Max Grav 1=800 (LC 1), 7=800 (LC 1)

FORCES (lb) - Maximum Compression/Maximum Tension
TOP CHORD 1-3=-1149/128, 3-4=-954/93, 4-5=-954/93, 5-7=-1149/128
BOT CHORD 1-7=-150/1069
WEBS 4-8=0/540, 3-8=-343/133, 5-8=-343/133

NOTES
1) Unbalanced roof live loads have been considered for this design.
2) Wind: ASCE 7-10; Vult=115mph (3-second gust) Vasd=91mph; TC DL=6.0psf; BC DL=6.0psf; h=30ft; Cat. II; Exp B; Enclosed; MWFRS (envelope) exterior zone and C-C Exterior (2) 0-0-0 to 4-9-14, Interior (1) 4-9-14 to 10-0-0, Exterior (2) 10-0-0 to 14-6-6, Interior (1) 14-6-6 to 20-0-0 zone; cantilever left and right exposed; end vertical left and right exposed; C-C for members and forces & MWFRS for reactions shown; Lumber DOL=1.60 plate grip DOL=1.60
3) This truss has been designed for a 10.0 psf bottom chord live load nonconcurrent with any other live loads.

4) * This truss has been designed for a live load of 20.0psf on the bottom chord in all areas where a rectangle 3-06-00 tall by 1-00-00 wide will fit between the bottom chord and any other members.
5) Provide mechanical connection (by others) of truss to bearing plate capable of withstanding 20 lb uplift at joint 1 and 20 lb uplift at joint 7.
6) This truss is designed in accordance with the 2015 International Residential Code sections R502.11.1 and R802.10.2 and referenced standard ANSI/TPI 1.

LOAD CASE(S) Standard



January 17, 2023

Job 36029A	Truss B4G	Truss Type Common Girder	Qty 1	Ply 2	57 SERENITY Job Reference (optional)	I56131957
---------------	--------------	-----------------------------	----------	----------	---	-----------

84 Components (Dunn), Dunn, NC - 28334,

Run: 8.63 S Nov 19 2022 Print: 8.630 S Nov 19 2022 MiTek Industries, Inc. Fri Jan 13 10:16:55
ID:cYDhCvUTk25rac9NzUJYzY6NJH-RfC?PsB70Hq3NSgPqnL8w3ulTXbGKwRcDoi7J4zJC?f

Page: 1

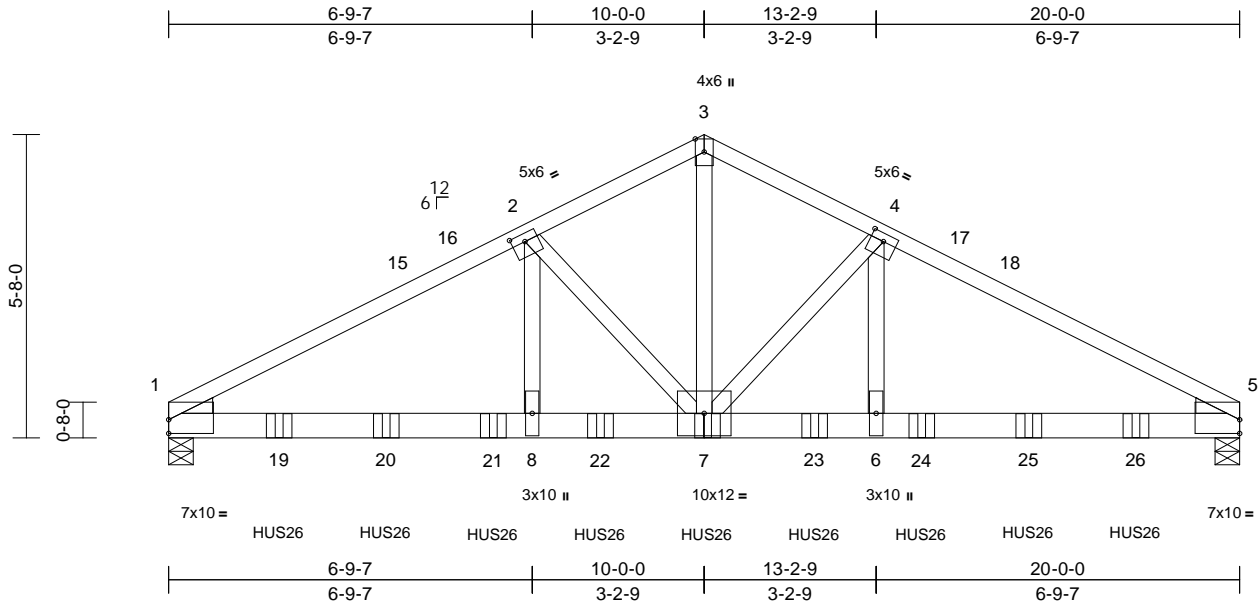

Scale = 1:43

Plate Offsets (X, Y): [1:Edge,0-3-1], [2:0-3-0,0-1-12], [4:0-3-0,0-1-12], [5:Edge,0-3-1]

Loading	(psf)	Spacing	2-0-0	CSI	DEFL	in	(loc)	l/defl	L/d	PLATES	GRIP	
TCLL (roof)	20.0	Plate Grip DOL	1.15	TC	0.97	Vert(LL)	-0.13	8-11	>999	240	MT20	244/190
TCDL	10.0	Lumber DOL	1.15	BC	0.72	Vert(CT)	-0.26	6-14	>927	180		
BCLL	0.0*	Rep Stress Incr	NO	WB	0.68	Horz(CT)	0.04	5	n/a	n/a		
BCDL	10.0	Code	IRC2015/TPI2014	Matrix-MS							Weight: 225 lb	FT = 20%

LUMBER

- TOP CHORD 2x4 SP No.2
- BOT CHORD 2x6 SP DSS
- WEBS 2x4 SP No.3 *Except* 7-3:2x4 SP No.2
- WEDGE Left: 2x4 SP No.3
Right: 2x4 SP No.3

BRACING

- TOP CHORD Structural wood sheathing directly applied.
- BOT CHORD Rigid ceiling directly applied or 10-0-0 oc bracing.

REACTIONS

- (size) 1=0-5-8, 5=0-5-8
- Max Horiz 1=-65 (LC 33)
- Max Uplift 1=-83 (LC 12)
- Max Grav 1=5476 (LC 1), 5=5615 (LC 1)

FORCES

- (lb) - Maximum Compression/Maximum Tension
- TOP CHORD 1-2=-8673/181, 2-3=-6442/165, 3-4=-6444/162, 4-5=-8707/27
- BOT CHORD 1-8=-133/7673, 6-8=-108/7791, 5-6=-95/7706
- WEBS 3-7=-101/5542, 2-7=-3036/141, 4-7=-3116/0, 4-6=0/3046, 2-8=-5/2932

NOTES

- 2-ply truss to be connected together with 10d (0.131"x3") nails as follows:
Top chords connected as follows: 2x4 - 1 row at 0-9-0 oc.
Bottom chords connected as follows: 2x6 - 2 rows staggered at 0-9-0 oc.
Web connected as follows: 2x4 - 1 row at 0-9-0 oc.
- All loads are considered equally applied to all plies, except if noted as front (F) or back (B) face in the LOAD CASE(S) section. Ply to ply connections have been provided to distribute only loads noted as (F) or (B), unless otherwise indicated.
- Unbalanced roof live loads have been considered for this design.

- Wind: ASCE 7-10; Vult=115mph (3-second gust)
Vasd=91mph; TC DL=6.0psf; BCDL=6.0psf; h=30ft; Cat. II; Exp B; Enclosed; MWFRS (envelope) exterior zone and C-C Exterior (2) 0-0-0 to 4-6-6, Interior (1) 4-6-6 to 10-0-0, Exterior (2) 10-0-0 to 14-6-6, Interior (1) 14-6-6 to 20-0-0 zone; cantilever left and right exposed; end vertical left and right exposed; C-C for members and forces & MWFRS for reactions shown; Lumber DOL=1.60 plate grip DOL=1.60
- This truss has been designed for a 10.0 psf bottom chord live load nonconcurrent with any other live loads.
- * This truss has been designed for a live load of 20.0psf on the bottom chord in all areas where a rectangle 3-06-00 tall by 1-00-00 wide will fit between the bottom chord and any other members.
- Provide mechanical connection (by others) of truss to bearing plate capable of withstanding 83 lb uplift at joint 1.
- This truss is designed in accordance with the 2015 International Residential Code sections R502.11.1 and R802.10.2 and referenced standard ANSI/TPI 1.
- Use MiTek HUS26 (With 14-16d nails into Girder & 6-16d nails into Truss) or equivalent spaced at 2-0-0 oc max. starting at 2-0-12 from the left end to 18-0-12 to connect truss(es) to front face of bottom chord.
- Fill all nail holes where hanger is in contact with lumber.

LOAD CASE(S) Standard

- Dead + Roof Live (balanced): Lumber Increase=1.15, Plate Increase=1.15
Uniform Loads (lb/ft)
Vert: 1-3=-60, 3-5=-60, 9-12=-20
Concentrated Loads (lb)
Vert: 7=-1042 (F), 19=-1042 (F), 20=-1042 (F), 21=-1042 (F), 22=-1042 (F), 23=-1042 (F), 24=-1043 (F), 25=-1043 (F), 26=-1151 (F)

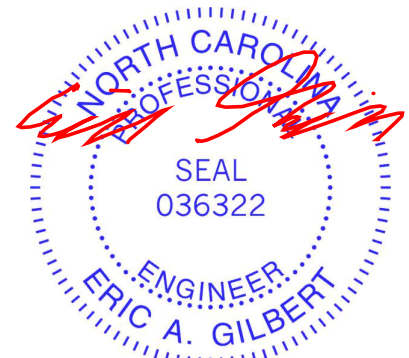

January 17, 2023

WARNING - Verify design parameters and READ NOTES ON THIS AND INCLUDED MITEK REFERENCE PAGE MII-7473 rev. 5/19/2020 BEFORE USE.

Design valid for use only with MiTek® connectors. This design is based only upon parameters shown, and is for an individual building component, not a truss system. Before use, the building designer must verify the applicability of design parameters and properly incorporate this design into the overall building design. Bracing indicated is to prevent buckling of individual truss web and/or chord members only. Additional temporary and permanent bracing is always required for stability and to prevent collapse with possible personal injury and property damage. For general guidance regarding the fabrication, storage, delivery, erection and bracing of trusses and truss systems, see **ANSI/TPI1 Quality Criteria, DSB-89 and BCSI Building Component Safety Information** available from Truss Plate Institute, 2670 Crain Highway, Suite 203 Waldorf, MD 20601



818 Soundside Road
Edenton, NC 27932

Job 36029A	Truss C1	Truss Type Common	Qty 3	Ply 1	57 SERENITY Job Reference (optional)	I56131958
---------------	-------------	----------------------	----------	----------	---	-----------

84 Components (Dunn), Dunn, NC - 28334,

Run: 8.63 S Nov 19 2022 Print: 8.630 S Nov 19 2022 MiTek Industries, Inc. Fri Jan 13 10:16:56
ID:ARSCP7pMrCKJ1xLrLsWFWy6MJQ-RfC?PsB70Hq3NSgPqnL8w3uTXbGKWrCDoi7J4zJC?f

Page: 1

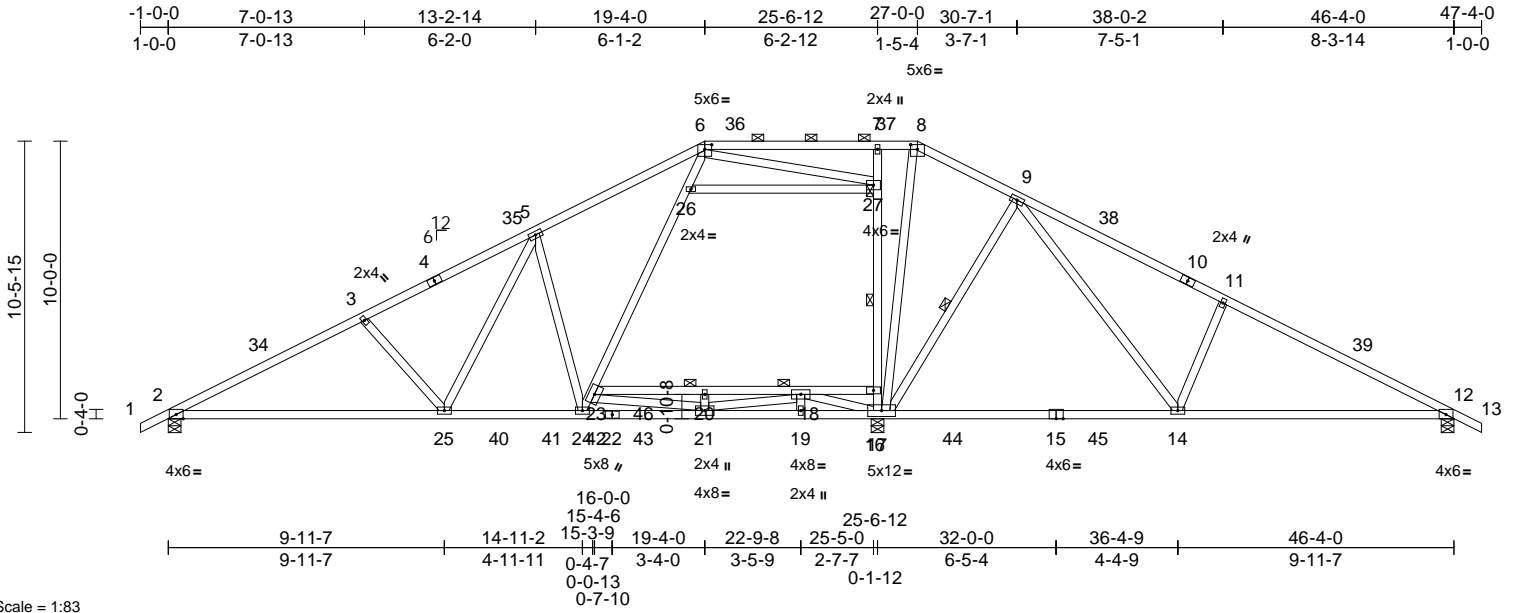

Scale = 1:83

Plate Offsets (X, Y): [6:0-3-0,0-2-0], [8:0-3-0,0-2-0]

Loading	(psf)	Spacing	2-0-0	CSI	DEFL	in	(loc)	l/defl	L/d	PLATES	GRIP	
TCLL (roof)	20.0	Plate Grip DOL	1.15	TC	0.92	Vert(LL)	-0.34	14-16	>734	240	MT20	244/190
TCDL	10.0	Lumber DOL	1.15	BC	0.81	Vert(CT)	-0.52	24	>584	180		
BCLL	0.0*	Rep Stress Incr	YES	WB	0.93	Horz(CT)	0.11	12	n/a	n/a		
BCDL	10.0	Code	IRC2015/TPI2014	Matrix-MS							Weight: 303 lb	FT = 20%

LUMBER
 TOP CHORD 2x4 SP No.2 *Except* 4-1,10-13:2x4 SP No.1
 BOT CHORD 2x4 SP DSS *Except* 15-12:2x4 SP No.1, 23-17:2x4 SP No.2
 WEBS 2x4 SP No.3 *Except* 24-6,7-16:2x4 SP No.1, 5-25,24-5,9-14,8-16,16-9,26-27,6-27:2x4 SP No.2

WEBS
 23-24=-120/688, 23-26=-34/1066, 6-26=-28/945, 3-25=-388/147, 5-25=-25/580, 5-24=-729/175, 9-14=-70/836, 11-14=-473/189, 16-17=-831/121, 17-27=-773/130, 7-27=-624/121, 8-16=-119/858, 9-16=-713/175, 18-19=-103/0, 20-21=-212/0, 21-23=0/1122, 18-21=0/1022, 16-18=-1025/0, 26-27=-17/303, 6-27=-768/46

LOAD CASE(S) Standard

BRACING
 TOP CHORD Structural wood sheathing directly applied or 2-2-1 oc purlins, except 2-0-0 oc purlins (2-2-0 max.): 6-8.
 BOT CHORD Rigid ceiling directly applied or 10-0-0 oc bracing. Except: 10-0-0 oc bracing: 17-23
 WEBS 1 Row at midpt 16-27, 9-16
 JOINTS 1 Brace at Jt(s): 27

NOTES
 1) Unbalanced roof live loads have been considered for this design.
 2) Wind: ASCE 7-10; Vult=115mph (3-second gust) Vasd=91mph; TCCL=6.0psf; BCDL=6.0psf; h=30ft; Cat. II; Exp B; Enclosed; MWFRS (envelope) exterior zone and C-C Exterior (2) -1-0-0 to 3-7-10, Interior (1) 3-7-10 to 19-4-0, Exterior (2) 19-4-0 to 25-10-10, Interior (1) 25-10-10 to 27-0-0, Exterior (2) 27-0-0 to 33-6-10, Interior (1) 33-6-10 to 47-4-0 zone; cantilever left and right exposed; end vertical left and right exposed; C-C for members and forces & MWFRS for reactions shown; Lumber DOL=1.60 plate grip DOL=1.60
 3) Provide adequate drainage to prevent water ponding.
 4) All plates are 3x6 MT20 unless otherwise indicated.
 5) This truss has been designed for a 10.0 psf bottom chord live load nonconcurrent with any other live loads.
 6) * This truss has been designed for a live load of 20.0psf on the bottom chord in all areas where a rectangle 3-06-00 tall by 1-00-00 wide will fit between the bottom chord and any other members, with BCDL = 10.0psf.
 7) Provide mechanical connection (by others) of truss to bearing plate capable of withstanding 2 lb uplift at joint 12 and 79 lb uplift at joint 2.
 8) This truss is designed in accordance with the 2015 International Residential Code sections R502.11.1 and R802.10.2 and referenced standard ANSI/TPI 1.
 9) Graphical purlin representation does not depict the size or the orientation of the purlin along the top and/or bottom chord.

REACTIONS (size) 2=0-5-8, 12=0-5-8, 16=0-5-8
 Max Horiz 2=-133 (LC 13)
 Max Uplift 2=-79 (LC 12), 12=-2 (LC 13)
 Max Grav 2=1585 (LC 23), 12=1440 (LC 1), 16=1420 (LC 26)

FORCES (lb) - Maximum Compression/Maximum Tension
 TOP CHORD 1-2=0/27, 2-3=-2912/156, 3-5=-2706/155, 5-6=-2277/220, 6-7=-1040/200, 7-8=-1354/222, 8-9=-1395/219, 9-11=-2366/213, 11-12=-2491/163, 12-13=0/27
 BOT CHORD 2-25=-187/2566, 24-25=-80/2120, 21-24=0/1825, 19-21=0/1693, 16-19=0/1727, 14-16=-10/1547, 12-14=-34/2180, 20-23=-1411/0, 18-20=-1411/0, 17-18=-25/613



January 17, 2023

WARNING - Verify design parameters and READ NOTES ON THIS AND INCLUDED MITEK REFERENCE PAGE MII-7473 rev. 5/19/2020 BEFORE USE.

Design valid for use only with MiTek® connectors. This design is based only upon parameters shown, and is for an individual building component, not a truss system. Before use, the building designer must verify the applicability of design parameters and properly incorporate this design into the overall building design. Bracing indicated is to prevent buckling of individual truss web and/or chord members only. Additional temporary and permanent bracing is always required for stability and to prevent collapse with possible personal injury and property damage. For general guidance regarding the fabrication, storage, delivery, erection and bracing of trusses and truss systems, see **ANSI/TPI Quality Criteria, DSB-89 and BCSI Building Component Safety Information** available from Truss Plate Institute, 2670 Crain Highway, Suite 203 Waldorf, MD 20601



818 Soundside Road
Edenton, NC 27932

Job 36029A	Truss C2	Truss Type Common	Qty 1	Ply 1	57 SERENITY Job Reference (optional)	I56131959
---------------	-------------	----------------------	----------	----------	---	-----------

84 Components (Dunn), Dunn, NC - 28334,

Run: 8.63 S Nov 19 2022 Print: 8.630 S Nov 19 2022 MiTek Industries, Inc. Fri Jan 13 10:16:56
ID:8i3eSRXZJr7c_Hu1s1_kkTy6Mec-RfC?PsB70Hq3NSgPqnL8w3ulTXhGKWRcDoi7J4zJC?f

Page: 1

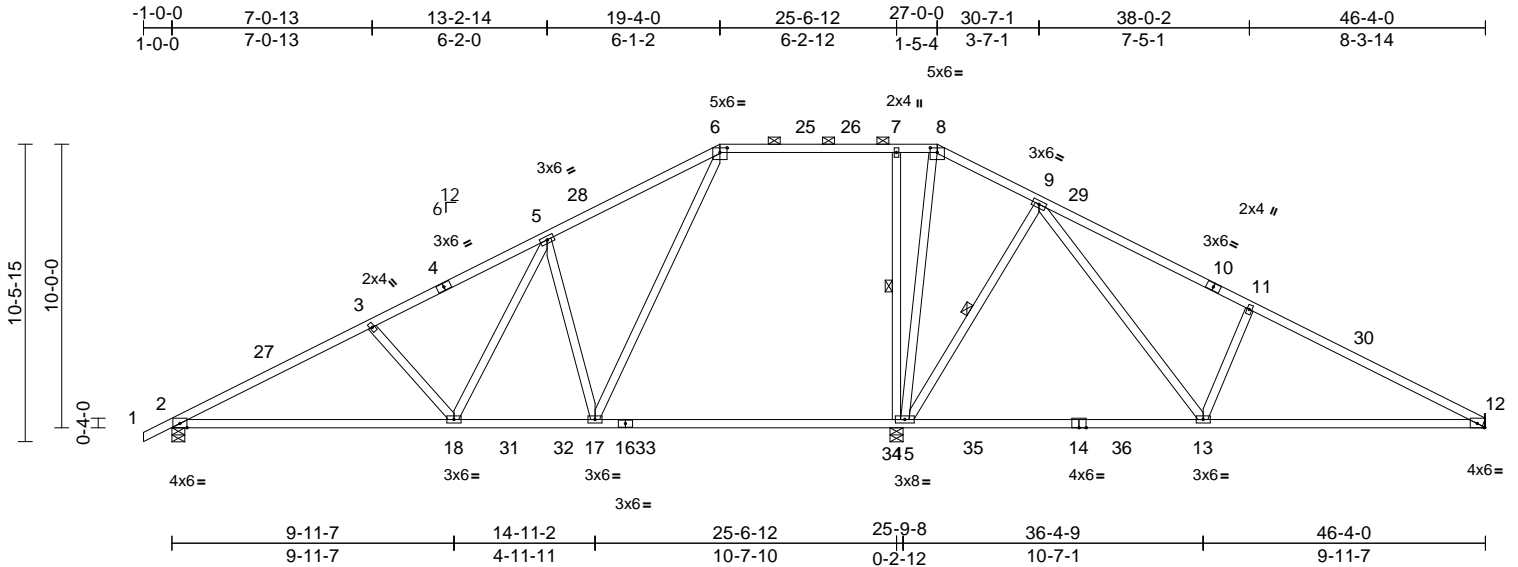

Scale = 1:81.3

Plate Offsets (X, Y): [6:0-3-0,0-2-0], [8:0-3-0,0-2-0]

Loading	(psf)	Spacing	2-0-0	CSI	DEFL	in	(loc)	l/defl	L/d	PLATES	GRIP	
TCLL (roof)	20.0	Plate Grip DOL	1.15	TC	1.00	Vert(LL)	-0.47	15-17	>661	240	MT20	244/190
TCDL	10.0	Lumber DOL	1.15	BC	0.84	Vert(CT)	-0.86	15-17	>360	180		
BCLL	0.0*	Rep Stress Incr	YES	WB	0.59	Horz(CT)	0.13	12	n/a	n/a		
BCDL	10.0	Code	IRC2015/TPI2014	Matrix-MS							Weight: 251 lb	FT = 20%

LUMBER
TOP CHORD 2x4 SP No.2 *Except* 10-12,4-1:2x4 SP No.1
BOT CHORD 2x4 SP DSS *Except* 12-14:2x4 SP No.1
WEBS 2x4 SP No.2 *Except* 3-18,11-13:2x4 SP No.3

BRACING
TOP CHORD Structural wood sheathing directly applied, except 2-0-0 oc purlins (2-2-0 max.): 6-8.
BOT CHORD Rigid ceiling directly applied or 10-0-0 oc bracing.
WEBS 1 Row at midpt 7-15, 9-15

REACTIONS (size) 2=0-5-8, 12= Mechanical, 15=0-5-8
Max Horiz 2=139 (LC 16)
Max Uplift 2=-139 (LC 12), 12=-29 (LC 12), 15=-63 (LC 13)
Max Grav 2=1726 (LC 23), 12=1609 (LC 1), 15=819 (LC 26)

FORCES (lb) - Maximum Compression/Maximum Tension
TOP CHORD 6-7=-1764/285, 7-8=-1749/283, 1-2=0/27, 2-3=-3164/290, 3-5=-2918/289, 5-6=-2498/329, 8-9=-1875/292, 9-11=-2855/296, 11-12=-3004/245
BOT CHORD 2-18=-312/2784, 17-18=-200/2306, 15-17=-117/1764, 13-15=-109/1971, 12-13=-132/2632
WEBS 5-18=-41/544, 5-17=-711/187, 9-13=-79/827, 3-18=-387/145, 11-13=-477/189, 6-17=-88/956, 7-15=-585/118, 8-15=-147/1034, 9-15=-701/179

NOTES
1) Unbalanced roof live loads have been considered for this design.

- 2) Wind: ASCE 7-10; Vult=115mph (3-second gust) Vasd=91mph; TC DL=6.0psf; BCDL=6.0psf; h=30ft; Cat. II; Exp B; Enclosed; MWFRS (envelope) exterior zone and C-C Exterior (2) -1-0-0 to 3-7-10, Interior (1) 3-7-10 to 19-4-0, Exterior (2) 19-4-0 to 23-11-10, Interior (1) 23-11-10 to 27-0-0, Exterior (2) 27-0-0 to 31-7-10, Interior (1) 31-7-10 to 46-4-0 zone; cantilever left and right exposed; end vertical left and right exposed; C-C for members and forces & MWFRS for reactions shown; Lumber DOL=1.60 plate grip DOL=1.60
- 3) Provide adequate drainage to prevent water ponding.
- 4) All plates are 3x6 MT20 unless otherwise indicated.
- 5) This truss has been designed for a 10.0 psf bottom chord live load nonconcurrent with any other live loads.
- 6) * This truss has been designed for a live load of 20.0psf on the bottom chord in all areas where a rectangle 3-06-00 tall by 1-00-00 wide will fit between the bottom chord and any other members, with BCDL = 10.0psf.
- 7) Refer to girder(s) for truss to truss connections.
- 8) Provide mechanical connection (by others) of truss to bearing plate capable of withstanding 29 lb uplift at joint 12, 139 lb uplift at joint 2 and 63 lb uplift at joint 15.
- 9) This truss is designed in accordance with the 2015 International Residential Code sections R502.11.1 and R802.10.2 and referenced standard ANSI/TPI 1.
- 10) Graphical purlin representation does not depict the size or the orientation of the purlin along the top and/or bottom chord.

LOAD CASE(S) Standard

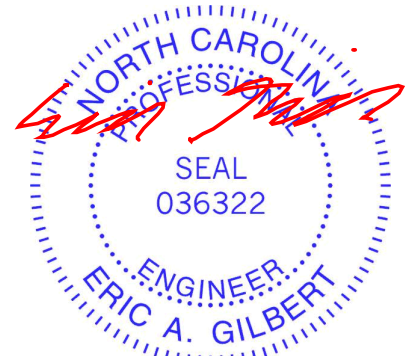

January 17, 2023

WARNING - Verify design parameters and READ NOTES ON THIS AND INCLUDED MITEK REFERENCE PAGE MII-7473 rev. 5/19/2020 BEFORE USE.

Design valid for use only with MiTek® connectors. This design is based only upon parameters shown, and is for an individual building component, not a truss system. Before use, the building designer must verify the applicability of design parameters and properly incorporate this design into the overall building design. Bracing indicated is to prevent buckling of individual truss web and/or chord members only. Additional temporary and permanent bracing is always required for stability and to prevent collapse with possible personal injury and property damage. For general guidance regarding the fabrication, storage, delivery, erection and bracing of trusses and truss systems, see

ANSI/TPI1 Quality Criteria, DSB-89 and BCSI Building Component

Safety Information available from Truss Plate Institute, 2670 Crain Highway, Suite 203 Waldorf, MD 20601



818 Soundside Road
Edenton, NC 27932

Job 36029A	Truss C2A	Truss Type Common	Qty 1	Ply 1	57 SERENITY Job Reference (optional)	I56131960
---------------	--------------	----------------------	----------	----------	---	-----------

84 Components (Dunn), Dunn, NC - 28334,

Run: 8.63 S Nov 19 2022 Print: 8.630 S Nov 19 2022 MiTek Industries, Inc. Fri Jan 13 10:16:57
ID:8i3eSRXZr7c_Hu1s1_kkTy6Mec-RfC?PsB70Hq3NSgPqnL8w3ulTXbGKWRcDoi7J4zJC?f

Page: 1

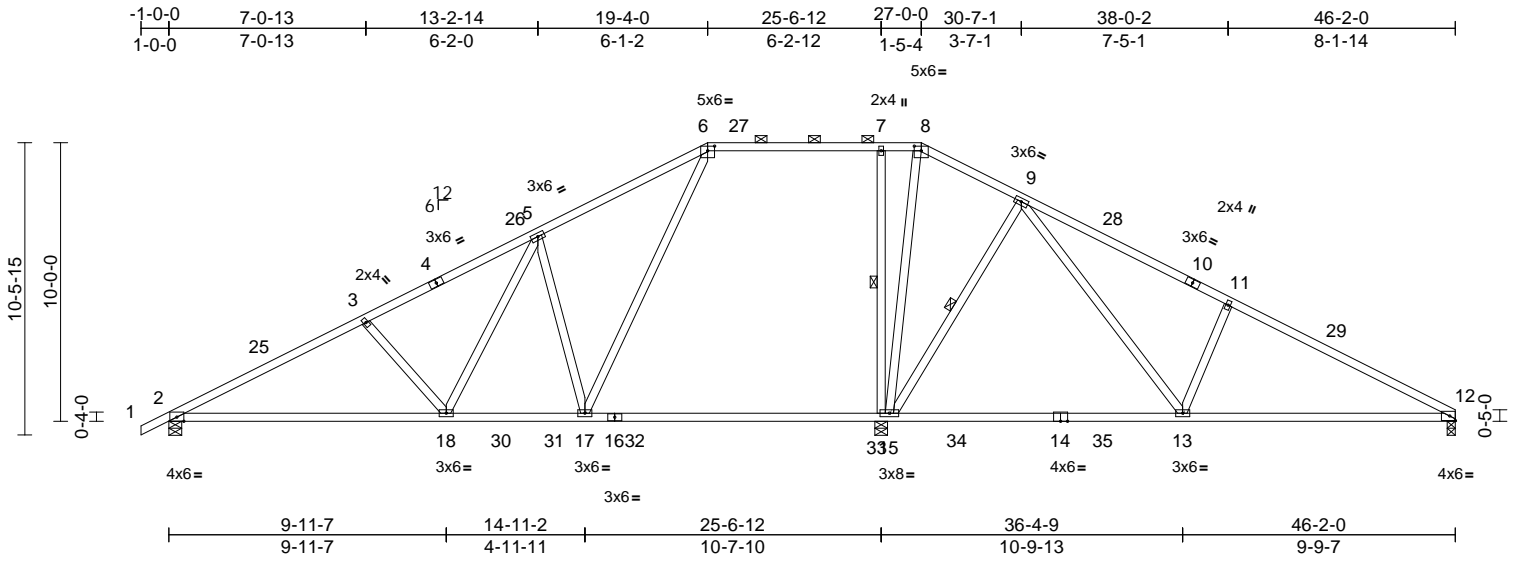

Scale = 1:82.7

Plate Offsets (X, Y): [6:0-3-0,0-2-0], [8:0-3-0,0-2-0]

Loading	(psf)	Spacing	2-0-0	CSI	DEFL	in	(loc)	l/defl	L/d	PLATES	GRIP	
TCLL (roof)	20.0	Plate Grip DOL	1.15	TC	0.80	Vert(LL)	-0.46	15-17	>672	240	MT20	244/190
TCDL	10.0	Lumber DOL	1.15	BC	0.75	Vert(CT)	-0.84	15-17	>367	180		
BCLL	0.0*	Rep Stress Incr	YES	WB	0.59	Horz(CT)	0.12	12	n/a	n/a		
BCDL	10.0	Code	IRC2015/TPI2014	Matrix-MS							Weight: 250 lb	FT = 20%

LUMBER
 TOP CHORD 2x4 SP No.1 *Except* 4-6,10-8:2x4 SP No.2
 BOT CHORD 2x4 SP DSS *Except* 12-14:2x4 SP No.1
 WEBS 2x4 SP No.2 *Except* 3-18,11-13:2x4 SP No.3

BRACING
 TOP CHORD Structural wood sheathing directly applied or 2-2-0 oc purlins, except 2-0-0 oc purlins (3-5-8 max.): 6-8.
 BOT CHORD Rigid ceiling directly applied or 10-0-0 oc bracing.
 WEBS 1 Row at midpt 7-15, 9-15

REACTIONS (size) 2=0-5-8, 12=0-3-8, 15=0-5-8
 Max Horiz 2=141 (LC 12)
 Max Uplift 2=-139 (LC 12), 12=-30 (LC 12), 15=-61 (LC 13)
 Max Grav 2=1722 (LC 23), 12=1605 (LC 1), 15=815 (LC 26)

FORCES (lb) - Maximum Compression/Maximum Tension
 TOP CHORD 1-2=0/27, 2-3=-3156/289, 3-5=-2909/288, 5-6=-2489/351, 6-7=-1756/326, 7-8=-1741/323, 8-9=-1868/329, 9-11=-2799/335, 11-12=-2970/284
 BOT CHORD 2-18=-313/2776, 17-18=-201/2298, 15-17=-118/1756, 13-15=-109/1955, 12-13=-169/2574
 WEBS 5-18=-41/544, 5-17=-711/187, 9-13=-79/785, 3-18=-387/145, 11-13=-456/189, 6-17=-88/956, 7-15=-600/129, 8-15=-173/1044, 9-15=-689/179

NOTES
 1) Unbalanced roof live loads have been considered for this design.

- 2) Wind: ASCE 7-10; Vult=115mph (3-second gust) Vasd=91mph; TC DL=6.0psf; BCDL=6.0psf; h=30ft; Cat. II; Exp B; Enclosed; MWFRS (envelope) exterior zone and C-C Exterior (2) -1-0-0 to 3-7-6, Interior (1) 3-7-6 to 19-4-0, Exterior (2) 19-4-0 to 25-6-12, Interior (1) 25-6-12 to 27-0-0, Exterior (2) 27-0-0 to 33-6-6, Interior (1) 33-6-6 to 46-2-0 zone; cantilever left and right exposed; end vertical left and right exposed; C-C for members and forces & MWFRS for reactions shown; Lumber DOL=1.60 plate grip DOL=1.60
- 3) Provide adequate drainage to prevent water ponding.
- 4) All plates are 3x6 MT20 unless otherwise indicated.
- 5) This truss has been designed for a 10.0 psf bottom chord live load nonconcurrent with any other live loads.
- 6) * This truss has been designed for a live load of 20.0psf on the bottom chord in all areas where a rectangle 3-06-00 tall by 1-00-00 wide will fit between the bottom chord and any other members, with BCDL = 10.0psf.
- 7) Provide mechanical connection (by others) of truss to bearing plate capable of withstanding 30 lb uplift at joint 12, 139 lb uplift at joint 2 and 61 lb uplift at joint 15.
- 8) This truss is designed in accordance with the 2015 International Residential Code sections R502.11.1 and R802.10.2 and referenced standard ANSI/TPI 1.
- 9) Graphical purlin representation does not depict the size or the orientation of the purlin along the top and/or bottom chord.

LOAD CASE(S) Standard



January 17, 2023

WARNING - Verify design parameters and READ NOTES ON THIS AND INCLUDED MITEK REFERENCE PAGE MII-7473 rev. 5/19/2020 BEFORE USE.

Design valid for use only with MiTek® connectors. This design is based only upon parameters shown, and is for an individual building component, not a truss system. Before use, the building designer must verify the applicability of design parameters and properly incorporate this design into the overall building design. Bracing indicated is to prevent buckling of individual truss web and/or chord members only. Additional temporary and permanent bracing is always required for stability and to prevent collapse with possible personal injury and property damage. For general guidance regarding the fabrication, storage, delivery, erection and bracing of trusses and truss systems, see

ANSI/TPI1 Quality Criteria, DSB-89 and BCSI Building Component

Safety Information available from Truss Plate Institute, 2670 Crain Highway, Suite 203 Waldorf, MD 20601



818 Soundside Road
 Edenton, NC 27932

Job 36029A	Truss C3	Truss Type Common Structural Gable	Qty 3	Ply 1	57 SERENITY Job Reference (optional)	156131961
---------------	-------------	---------------------------------------	----------	----------	---	-----------

84 Components (Dunn), Dunn, NC - 28334,

Run: 8.63 S Nov 19 2022 Print: 8.630 S Nov 19 2022 MiTek Industries, Inc. Fri Jan 13 10:16:57
ID: ?zX1aR2TILFeMZHCB68sDy6MUw-RfC?PsB70Hq3NSgPqnL8w3uITXbGKwRCDoi7J4zJC?f

Page: 1

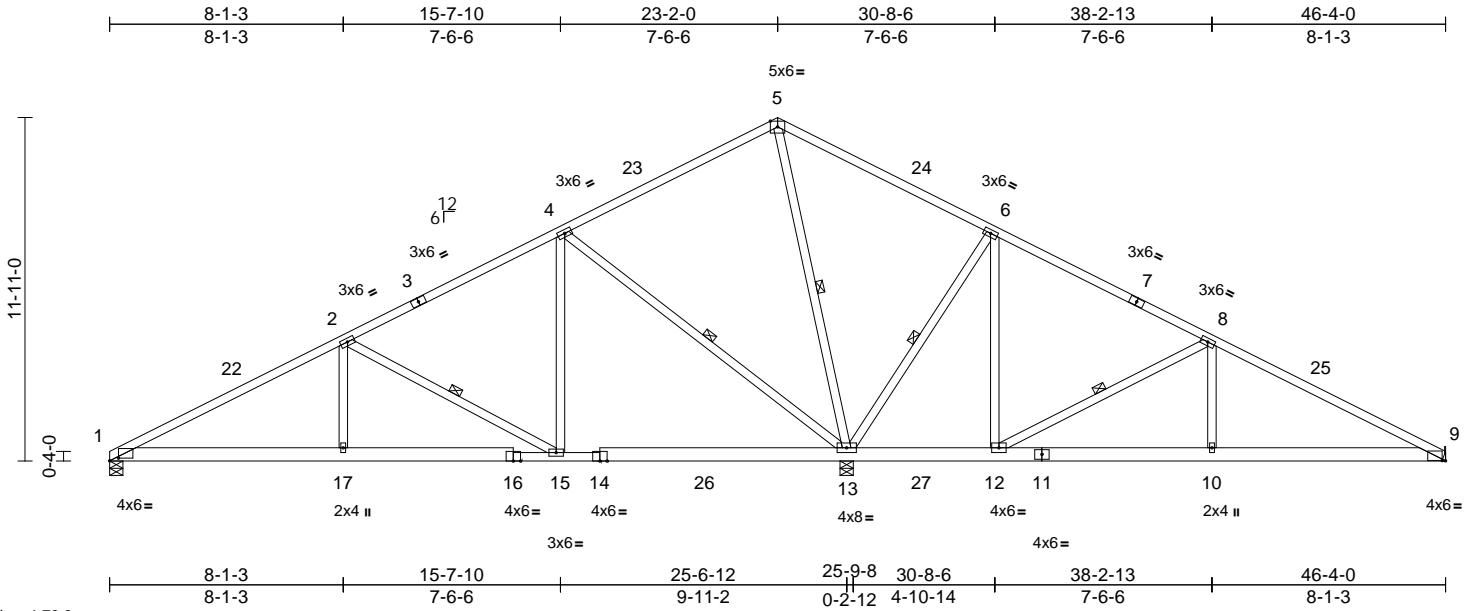

Loading	(psf)	Spacing	2-0-0	CSI	DEFL	in	(loc)	l/defl	L/d	PLATES	GRIP	
TCLL (roof)	20.0	Plate Grip DOL	1.15	TC	0.85	Vert(LL)	-0.08	13-15	>999	240	MT20	244/190
TCDL	10.0	Lumber DOL	1.15	BC	0.62	Vert(CT)	-0.16	13-15	>999	180		
BCLL	0.0*	Rep Stress Incr	YES	WB	0.70	Horz(CT)	0.03	9	n/a	n/a		
BCDL	10.0	Code	IRC2015/TPI2014	Matrix-MS							Weight: 289 lb	FT = 20%

LUMBER
TOP CHORD 2x4 SP No.2
BOT CHORD 2x6 SP No.2 *Except* 16-14:2x4 SP No.2
WEBS 2x4 SP No.2 *Except* 8-10,2-17:2x4 SP No.3

BRACING
TOP CHORD Structural wood sheathing directly applied or 4-3-14 oc purlins.
BOT CHORD Rigid ceiling directly applied or 6-0-0 oc bracing.
WEBS 1 Row at midpt 5-13, 6-13, 8-12, 4-13, 2-15

REACTIONS (size) 1=0-5-8, 9= Mechanical, 13=0-5-8
Max Horiz 1=152 (LC 12)
Max Uplift 1=-39 (LC 12), 9=-54 (LC 13), 13=-26 (LC 12)
Max Grav 1=772 (LC 23), 9=548 (LC 24), 13=2550 (LC 1)

FORCES (lb) - Maximum Compression/Maximum Tension
TOP CHORD 1-2=-1236/80, 2-4=-481/78, 4-5=0/703, 5-6=0/956, 6-8=-34/477, 8-9=-737/110
BOT CHORD 1-17=-140/1028, 15-17=-140/1030, 13-15=-24/366, 12-13=-397/123, 10-12=-43/580, 9-10=-43/580
WEBS 5-13=-1092/35, 6-13=-824/183, 6-12=0/451, 8-12=-782/125, 8-10=0/387, 4-13=-981/165, 4-15=0/592, 2-15=-781/132, 2-17=0/376

- Wind: ASCE 7-10; Vult=115mph (3-second gust) Vasd=91mph; TC DL=6.0psf; BCDL=6.0psf; h=30ft; Cat. II; Exp B; Enclosed; MWFRS (envelope) exterior zone and C-C Exterior (2) 0-0-0 to 4-7-10, Interior (1) 4-7-10 to 23-2-0, Exterior (2) 23-2-0 to 27-9-10, Interior (1) 27-9-10 to 46-3-4 zone; cantilever left and right exposed; end vertical left and right exposed; C-C for members and forces & MWFRS for reactions shown; Lumber DOL=1.60 plate grip DOL=1.60
- This truss has been designed for a 10.0 psf bottom chord live load nonconcurrent with any other live loads.
- * This truss has been designed for a live load of 20.0psf on the bottom chord in all areas where a rectangle 3-06-00 tall by 1-00-00 wide will fit between the bottom chord and any other members, with BCDL = 10.0psf.
- Refer to girder(s) for truss to truss connections.
- Provide mechanical connection (by others) of truss to bearing plate capable of withstanding 39 lb uplift at joint 1, 26 lb uplift at joint 13 and 54 lb uplift at joint 9.
- This truss is designed in accordance with the 2015 International Residential Code sections R502.11.1 and R802.10.2 and referenced standard ANSI/TPI 1.

LOAD CASE(S) Standard

NOTES
1) Unbalanced roof live loads have been considered for this design.

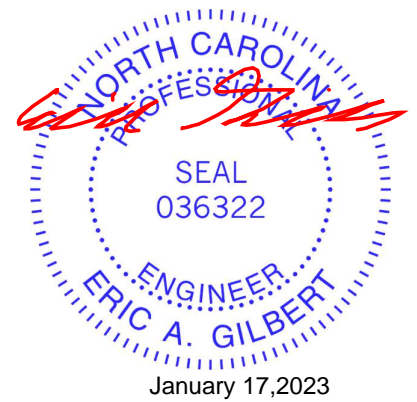

WARNING - Verify design parameters and READ NOTES ON THIS AND INCLUDED MITEK REFERENCE PAGE MII-7473 rev. 5/19/2020 BEFORE USE.
Design valid for use only with MiTek® connectors. This design is based only upon parameters shown, and is for an individual building component, not a truss system. Before use, the building designer must verify the applicability of design parameters and properly incorporate this design into the overall building design. Bracing indicated is to prevent buckling of individual truss web and/or chord members only. Additional temporary and permanent bracing is always required for stability and to prevent collapse with possible personal injury and property damage. For general guidance regarding the fabrication, storage, delivery, erection and bracing of trusses and truss systems, see **ANSI/TPI1 Quality Criteria, DSB-89 and BCSI Building Component Safety Information** available from Truss Plate Institute, 2670 Crain Highway, Suite 203 Waldorf, MD 20601

ENGINEERING BY
TRENCO
A MiTek Affiliate
818 Soundside Road
Edenton, NC 27932

Job 36029A	Truss C4E	Truss Type Common Structural Gable	Qty 1	Ply 1	57 SERENITY Job Reference (optional)	I56131962
---------------	--------------	---------------------------------------	----------	----------	---	-----------

84 Components (Dunn), Dunn, NC - 28334,

Run: 8.63 S Nov 19 2022 Print: 8.630 S Nov 19 2022 MiTek Industries, Inc. Fri Jan 13 10:16:58
ID:OLtS_PDI2LihFa9VuBo1LzY6MPX-RfC?PsB70Hq3NSgPqnL8w3uITxBGKWrCdoi7J4zJC7f

Page: 1

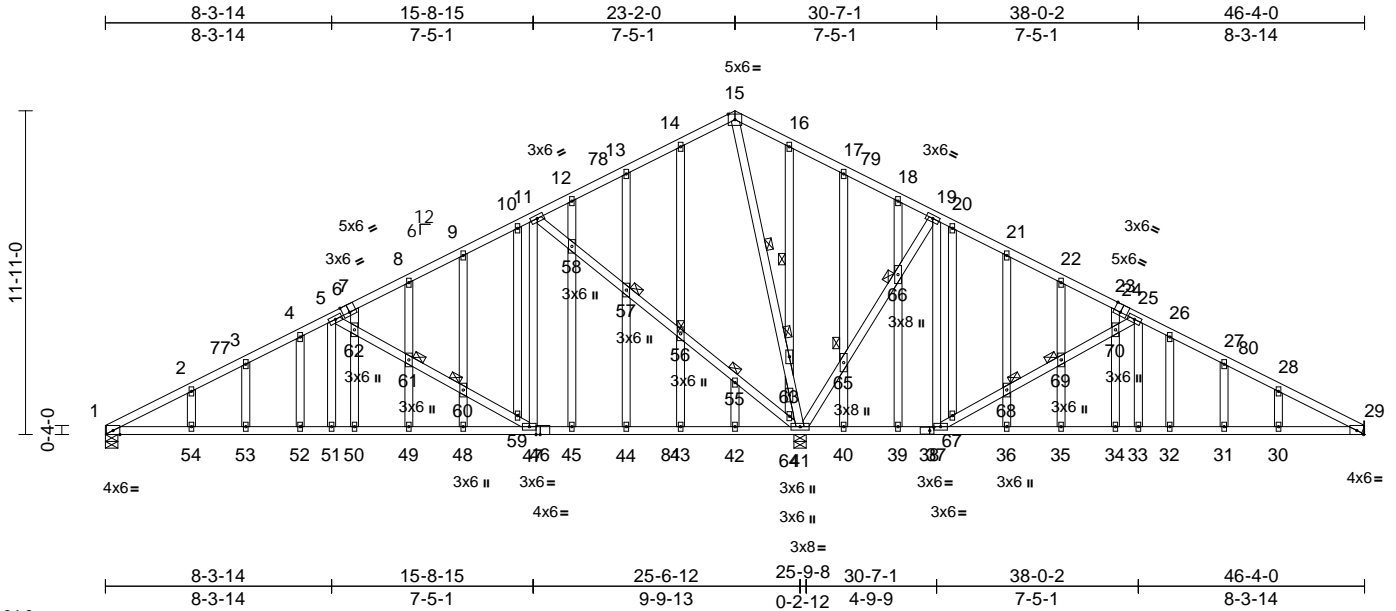

Scale = 1:84.8

Plate Offsets (X, Y): [6:0-3-0,Edge], [24:0-3-0,Edge], [38:0-1-13,0-1-8], [46:0-1-13,Edge]

Loading	(psf)	Spacing	2-0-0	CSI	DEFL	in (loc)	l/defl	L/d	PLATES	GRIP		
TCLL (roof)	20.0	Plate Grip DOL	1.15	TC	0.67	Vert(LL)	-0.18	53-54	>999	240	MT20	244/190
TCDL	10.0	Lumber DOL	1.15	BC	0.86	Vert(CT)	-0.36	53-54	>844	180		
BCLL	0.0*	Rep Stress Incr	YES	WB	0.46	Horz(CT)	0.03	41	n/a	n/a		
BCDL	10.0	Code	IRC2015/TPI2014	Matrix-MS								Weight: 427 lb FT = 20%

LUMBER
TOP CHORD 2x4 SP No.2
BOT CHORD 2x4 SP No.2
WEBS 2x4 SP No.2 *Except* 25-33,5-51:2x4 SP No.3
OTHERS 2x4 SP No.3 *Except* 56-14,45-58,59-10,63-16,65-17,67-20:2x4 SP No.2

BRACING
TOP CHORD Structural wood sheathing directly applied or 4-3-14 oc purlins.
BOT CHORD Rigid ceiling directly applied or 6-0-0 oc bracing.
WEBS 1 Row at midpt 15-63, 16-63
JOINTS 1 Brace at Jt(s): 55, 56, 57, 60, 61, 63, 65, 66, 68, 69

REACTIONS (size) 1=0-5-8, 29= Mechanical, 41=0-5-8
Max Horiz 1=-151 (LC 13)
Max Uplift 1=-39 (LC 12), 29=-57 (LC 13), 41=-24 (LC 12)
Max Grav 1=782 (LC 23), 29=552 (LC 24), 41=2542 (LC 1)

FORCES (lb) - Maximum Compression/Maximum Tension
TOP CHORD 1-2=-1191/27, 2-3=-1146/57, 3-4=-1120/87, 4-5=-1065/105, 5-7=-503/30, 7-8=-433/42, 8-9=-416/68, 9-10=-403/96, 10-11=-279/99, 11-12=-3/544, 12-13=0/614, 13-14=0/601, 14-15=0/693, 15-16=0/889, 16-17=0/846, 17-18=0/867, 18-19=0/807, 19-20=0/466, 20-21=0/434, 21-22=-16/422, 22-23=-36/416, 23-25=-50/363, 25-26=-564/144, 26-27=-620/126, 27-28=-645/97, 28-29=-691/66

BOT CHORD 1-54=-138/1017, 53-54=-138/1017, 52-53=-138/1017, 51-52=-138/1017, 50-51=-138/1017, 49-50=-138/1017, 48-49=-138/1017, 47-48=-138/1017, 45-47=-23/367, 44-45=-23/367, 43-44=-23/367, 42-43=-23/367, 41-42=-23/367, 40-41=-374/121, 39-40=-374/121, 37-39=-374/121, 36-37=-22/570, 35-36=-22/570, 34-35=-22/570, 33-34=-22/570, 32-33=-22/570, 31-32=-22/570, 30-31=-22/570, 29-30=-24/570
WEBS 15-63=-997/0, 41-63=-1062/0, 41-65=-782/143, 65-66=-773/137, 19-66=-748/134, 19-37=-61/485, 37-67=-791/139, 67-68=-834/142, 68-69=-798/138, 69-70=-768/132, 25-70=-872/150, 25-33=-55/376, 11-58=-963/162, 57-58=-932/158, 56-57=-987/166, 55-56=-983/169, 55-64=-980/161, 41-64=-950/160, 11-47=-61/480, 5-62=-829/146, 61-62=-734/129, 60-61=-765/135, 59-60=-797/139, 47-59=-712/131, 5-51=-54/357, 42-55=-24/24, 14-56=0/132, 43-56=0/112, 13-57=-150/54, 44-57=-62/41, 12-58=0/89, 45-58=-2/54, 10-59=-13/174, 9-60=-85/48, 48-60=-19/46, 8-61=-83/46, 49-61=-21/34, 7-62=0/118, 50-62=-88/40, 4-52=-5/39, 3-53=-50/39, 2-54=-51/50, 16-63=-97/85, 63-64=-45/139, 17-65=-156/50, 40-65=-149/42, 18-66=0/51, 39-66=0/76, 20-67=-6/82, 21-68=-80/48, 36-68=-7/57, 22-69=-86/46, 35-69=-25/34, 23-70=0/128, 34-70=-94/41, 26-32=-3/41, 27-31=-51/39, 28-30=-51/50

- Wind: ASCE 7-10; Vult=115mph (3-second gust) Vasd=91mph; TCDL=6.0psf; BCDL=6.0psf; h=30ft; Cat. II; Exp B; Enclosed; MWFRS (envelope) exterior zone and C-C Exterior (2) 0-0-0 to 4-7-10, Interior (1) 4-7-10 to 23-2-0, Exterior (2) 23-2-0 to 27-9-10, Interior (1) 27-9-10 to 46-4-0 zone; cantilever left and right exposed; end vertical left and right exposed; C-C for members and forces & MWFRS for reactions shown; Lumber DOL=1.60 plate grip DOL=1.60
- Truss designed for wind loads in the plane of the truss only. For studs exposed to wind (normal to the face), see Standard Industry Gable End Details as applicable, or consult qualified building designer as per ANSI/TPI 1.
- All plates are 2x4 MT20 unless otherwise indicated.
- Gable studs spaced at 2-0-0 oc.
- This truss has been designed for a 10.0 psf bottom chord live load nonconcurrent with any other live loads.
- * This truss has been designed for a live load of 20.0psf on the bottom chord in all areas where a rectangle 3-06-00 tall by 1-00-00 wide will fit between the bottom chord and any other members, with BCDL = 10.0psf.
- Refer to girder(s) for truss to truss connections.

NOTES

- Unbalanced roof live loads have been considered for this design.

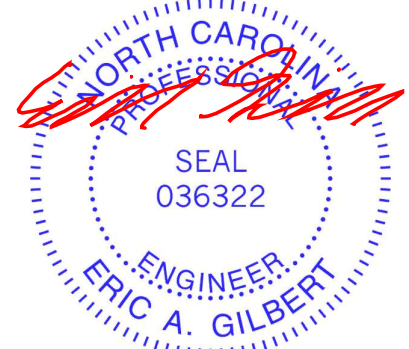

January 17, 2023

Continued on page 2

WARNING - Verify design parameters and READ NOTES ON THIS AND INCLUDED MITEK REFERENCE PAGE MII-7473 rev. 5/19/2020 BEFORE USE.

Design valid for use only with MiTek® connectors. This design is based only upon parameters shown, and is for an individual building component, not a truss system. Before use, the building designer must verify the applicability of design parameters and properly incorporate this design into the overall building design. Bracing indicated is to prevent buckling of individual truss web and/or chord members only. Additional temporary and permanent bracing is always required for stability and to prevent collapse with possible personal injury and property damage. For general guidance regarding the fabrication, storage, delivery, erection and bracing of trusses and truss systems, see **ANSI/TPI1 Quality Criteria, DSB-89 and BCSI Building Component Safety Information** available from Truss Plate Institute, 2670 Crain Highway, Suite 203 Waldorf, MD 20601



818 Soundside Road
Edenton, NC 27932

Job 36029A	Truss C4E	Truss Type Common Structural Gable	Qty 1	Ply 1	57 SERENITY Job Reference (optional)	I56131962
---------------	--------------	---------------------------------------	----------	----------	---	-----------

84 Components (Dunn), Dunn, NC - 28334,

Run: 8.63 S Nov 19 2022 Print: 8.630 S Nov 19 2022 MiTek Industries, Inc. Fri Jan 13 10:16:58
ID:OLIS_PDI2LihFa9VuBo1Lzy6MPX-RfC?PsB70Hq3NSgPqnL8w3uITXbGKWrCDoi7J4zJC?f

Page: 2

- 9) Provide mechanical connection (by others) of truss to bearing plate capable of withstanding 39 lb uplift at joint 1, 24 lb uplift at joint 41 and 57 lb uplift at joint 29.
- 10) This truss is designed in accordance with the 2015 International Residential Code sections R502.11.1 and R802.10.2 and referenced standard ANSI/TPI 1.

LOAD CASE(S) Standard

WARNING - Verify design parameters and READ NOTES ON THIS AND INCLUDED MITEK REFERENCE PAGE MII-7473 rev. 5/19/2020 BEFORE USE.

Design valid for use only with MiTek® connectors. This design is based only upon parameters shown, and is for an individual building component, not a truss system. Before use, the building designer must verify the applicability of design parameters and properly incorporate this design into the overall building design. Bracing indicated is to prevent buckling of individual truss web and/or chord members only. Additional temporary and permanent bracing is always required for stability and to prevent collapse with possible personal injury and property damage. For general guidance regarding the fabrication, storage, delivery, erection and bracing of trusses and truss systems, see **ANSI/TPI1 Quality Criteria, DSB-89 and BCSI Building Component Safety Information** available from Truss Plate Institute, 2670 Crain Highway, Suite 203 Waldorf, MD 20601



818 Soundside Road
Edenton, NC 27932

Job 36029A	Truss D1E	Truss Type Common Supported Gable	Qty 1	Ply 1	57 SERENITY Job Reference (optional)	156131963
---------------	--------------	--------------------------------------	----------	----------	---	-----------

84 Components (Dunn), Dunn, NC - 28334,

Run: 8.63 S Nov 19 2022 Print: 8.630 S Nov 19 2022 MiTek Industries, Inc. Fri Jan 13 10:16:59
 ID:R3nkdzOnUo5VhxSIXGa8Ry6MEE-RfC?PsB70Hq3NSgPqnL8w3uITXbGKWrCDoi7J4zJC?f

Page: 1

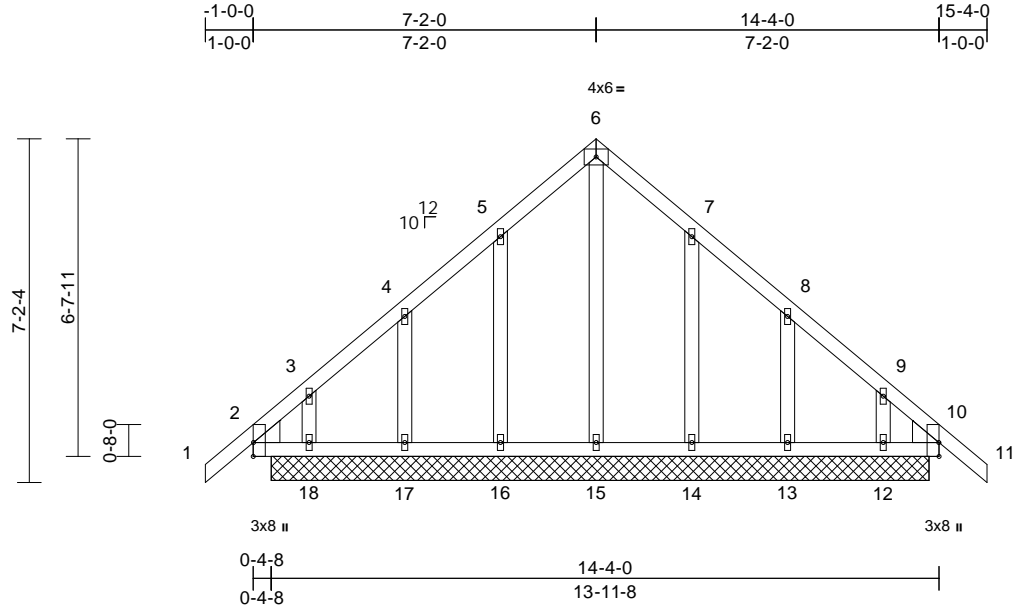

Scale = 1:48.2
 Plate Offsets (X, Y): [2:Edge,0-0-1], [10:Edge,0-0-1]

Loading	(psf)	Spacing	2-0-0	CSI	DEFL	in	(loc)	l/defl	L/d	PLATES	GRIP	
TCLL (roof)	20.0	Plate Grip DOL	1.15	TC	0.07	Vert(LL)	n/a	-	n/a	999	MT20	244/190
TCDL	10.0	Lumber DOL	1.15	BC	0.10	Vert(CT)	n/a	-	n/a	999		
BCLL	0.0*	Rep Stress Incr	YES	WB	0.09	Horz(CT)	0.00	10	n/a	n/a		
BCDL	10.0	Code	IRC2015/TPI2014	Matrix-MP							Weight: 90 lb	FT = 20%

LUMBER
 TOP CHORD 2x4 SP No.2
 BOT CHORD 2x4 SP No.2
 OTHERS 2x4 SP No.3
 WEDGE Left: 2x6 SP No.2
 Right: 2x6 SP No.2

BRACING
 TOP CHORD Structural wood sheathing directly applied or 6-0-0 oc purlins.
 BOT CHORD Rigid ceiling directly applied or 6-0-0 oc bracing.

REACTIONS (size)
 2=13-9-0, 10=13-9-0, 12=13-9-0,
 13=13-9-0, 14=13-9-0, 15=13-9-0,
 16=13-9-0, 17=13-9-0, 18=13-9-0,
 21=13-9-0, 23=13-9-0
 Max Horiz 2=-132 (LC 10), 21=-132 (LC 10)
 Max Uplift 2=-65 (LC 8), 10=-29 (LC 9),
 12=-70 (LC 13), 13=-54 (LC 13),
 14=-62 (LC 13), 16=-63 (LC 12),
 17=-51 (LC 12), 18=-152 (LC 12),
 21=-65 (LC 8), 23=-29 (LC 9)
 Max Grav 2=251 (LC 20), 10=119 (LC 24),
 12=137 (LC 20), 13=166 (LC 20),
 14=211 (LC 20), 15=233 (LC 22),
 16=211 (LC 19), 17=168 (LC 19),
 18=127 (LC 10), 21=251 (LC 20),
 23=119 (LC 24)

FORCES (lb) - Maximum Compression/Maximum Tension
 TOP CHORD 1-2=0/38, 2-3=-135/96, 3-4=-69/83,
 4-5=-56/72, 5-6=-116/119, 6-7=-116/119,
 7-8=-56/66, 8-9=-63/74, 9-10=-109/88,
 10-11=0/38
 BOT CHORD 2-18=-67/114, 17-18=-67/114, 16-17=-67/114,
 15-16=-67/114, 14-15=-67/114,
 13-14=-67/114, 12-13=-67/114,
 10-12=-67/114

WEBS 6-15=-124/57, 5-16=-142/85, 4-17=-129/80,
 3-18=-118/101, 7-14=-142/85, 8-13=-129/80,
 9-12=-111/73

- NOTES**
- 1) Unbalanced roof live loads have been considered for this design.
 - 2) Wind: ASCE 7-10; Vult=115mph (3-second gust) Vasd=91mph; TC DL=6.0psf; BCDL=6.0psf; h=30ft; Cat. II; Exp B; Enclosed; MWFRS (envelope) exterior zone and C-C Corner (3) -1-0-0 to 3-6-6, Exterior (2) 3-6-6 to 7-2-0, Corner (3) 7-2-0 to 11-8-6, Exterior (2) 11-8-6 to 15-4-0 zone; cantilever left and right exposed; end vertical left and right exposed; C-C for members and forces & MWFRS for reactions shown; Lumber DOL=1.60 plate grip DOL=1.60
 - 3) Truss designed for wind loads in the plane of the truss only. For studs exposed to wind (normal to the face), see Standard Industry Gable End Details as applicable, or consult qualified building designer as per ANSI/TPI 1.
 - 4) All plates are 1.5x4 MT20 unless otherwise indicated.
 - 5) Gable studs spaced at 2-0-0 oc.
 - 6) This truss has been designed for a 10.0 psf bottom chord live load nonconcurrent with any other live loads.
 - 7) * This truss has been designed for a live load of 20.0psf on the bottom chord in all areas where a rectangle 3-06-00 tall by 1-00-00 wide will fit between the bottom chord and any other members, with BCDL = 10.0psf.
 - 8) Provide mechanical connection (by others) of truss to bearing plate capable of withstanding 65 lb uplift at joint 2, 29 lb uplift at joint 10, 63 lb uplift at joint 16, 51 lb uplift at joint 17, 152 lb uplift at joint 18, 62 lb uplift at joint 14, 54 lb uplift at joint 13, 70 lb uplift at joint 12, 65 lb uplift at joint 2 and 29 lb uplift at joint 10.
 - 9) Non Standard bearing condition. Review required.
 - 10) This truss is designed in accordance with the 2015 International Residential Code sections R502.11.1 and R802.10.2 and referenced standard ANSI/TPI 1.

LOAD CASE(S) Standard



January 17, 2023

Job 36029A	Truss D2	Truss Type Common	Qty 4	Ply 1	57 SERENITY Job Reference (optional)	156131964
---------------	-------------	----------------------	----------	----------	---	-----------

84 Components (Dunn), Dunn, NC - 28334,

Run: 8.63 S Nov 19 2022 Print: 8.630 S Nov 19 2022 MiTek Industries, Inc. Fri Jan 13 10:17:00
ID:8NN2Cj1a3Wuc2CfNv0rDi_y6MCs-RfC?PsB70Hq3NSgPqnL8w3uITxbGKWrCdoi7J4zJC?f

Page: 1

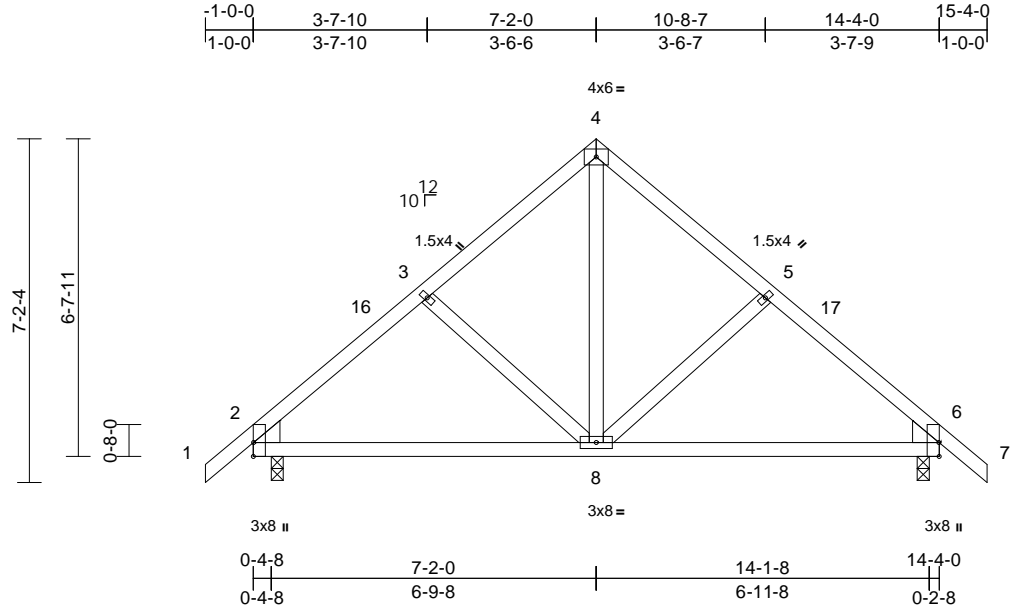

Scale = 1:48.2

Plate Offsets (X, Y): [2:Edge,0-0-1], [6:Edge,0-0-1]

Loading	(psf)	Spacing	2-0-0	CSI	DEFL	in	(loc)	l/defl	L/d	PLATES	GRIP	
TCLL (roof)	20.0	Plate Grip DOL	1.15	TC	0.44	Vert(LL)	-0.04	8-15	>999	240	MT20	244/190
TCDL	10.0	Lumber DOL	1.15	BC	0.45	Vert(CT)	-0.08	8-15	>999	180		
BCLL	0.0*	Rep Stress Incr	YES	WB	0.13	Horz(CT)	-0.01	2	n/a	n/a		
BCDL	10.0	Code	IRC2015/TPI2014	Matrix-MP							Weight: 79 lb	FT = 20%

LUMBER

TOP CHORD 2x4 SP No.2
 BOT CHORD 2x4 SP No.2
 WEBS 2x4 SP No.3
 WEDGE Left: 2x6 SP DSS
 Right: 2x6 SP No.2

BRACING

TOP CHORD Structural wood sheathing directly applied or 6-0-0 oc purlins.
 BOT CHORD Rigid ceiling directly applied or 10-0-0 oc bracing.

REACTIONS

(size) 2=0-3-0, 6=0-3-0
 Max Horiz 2=-132 (LC 10)
 Max Uplift 2=-18 (LC 12), 6=-18 (LC 13)
 Max Grav 2=656 (LC 1), 6=610 (LC 1)

FORCES

(lb) - Maximum Compression/Maximum Tension
 TOP CHORD 1-2=0/38, 2-3=-603/66, 3-4=-466/79,
 4-5=-476/82, 5-6=-617/70, 6-7=0/38
 BOT CHORD 2-8=-37/422, 6-8=0/441
 WEBS 4-8=-43/358, 3-8=-151/117, 5-8=-205/118

NOTES

- Unbalanced roof live loads have been considered for this design.
- Wind: ASCE 7-10; Vult=115mph (3-second gust) Vasd=91mph; TCCL=6.0psf; BCDL=6.0psf; h=30ft; Cat. II; Exp B; Enclosed; MWFRS (envelope) exterior zone and C-C Exterior (2) -1-0-0 to 3-6-4, Interior (1) 3-6-4 to 7-2-0, Exterior (2) 7-2-0 to 11-8-6, Interior (1) 11-8-6 to 15-4-0 zone; cantilever left and right exposed; end vertical left and right exposed; C-C for members and forces & MWFRS for reactions shown; Lumber DOL=1.60 plate grip DOL=1.60
- This truss has been designed for a 10.0 psf bottom chord live load nonconcurrent with any other live loads.

- * This truss has been designed for a live load of 20.0psf on the bottom chord in all areas where a rectangle 3-06-00 tall by 1-00-00 wide will fit between the bottom chord and any other members.
- Provide mechanical connection (by others) of truss to bearing plate capable of withstanding 18 lb uplift at joint 2 and 18 lb uplift at joint 6.
- This truss is designed in accordance with the 2015 International Residential Code sections R502.11.1 and R802.10.2 and referenced standard ANSI/TPI 1.

LOAD CASE(S) Standard



January 17, 2023

WARNING - Verify design parameters and READ NOTES ON THIS AND INCLUDED MITEK REFERENCE PAGE MII-7473 rev. 5/19/2020 BEFORE USE.

Design valid for use only with MiTek® connectors. This design is based only upon parameters shown, and is for an individual building component, not a truss system. Before use, the building designer must verify the applicability of design parameters and properly incorporate this design into the overall building design. Bracing indicated is to prevent buckling of individual truss web and/or chord members only. Additional temporary and permanent bracing is always required for stability and to prevent collapse with possible personal injury and property damage. For general guidance regarding the fabrication, storage, delivery, erection and bracing of trusses and truss systems, see **ANSI/TPI1 Quality Criteria, DSB-89 and BCSI Building Component Safety Information** available from Truss Plate Institute, 2670 Crain Highway, Suite 203 Waldorf, MD 20601



818 Soundside Road
 Edenton, NC 27932

Job 36029A	Truss E1E	Truss Type Common Supported Gable	Qty 1	Ply 1	57 SERENITY Job Reference (optional)	156131965
---------------	--------------	--------------------------------------	----------	----------	---	-----------

84 Components (Dunn), Dunn, NC - 28334,

Run: 8.63 S Nov 19 2022 Print: 8.630 S Nov 19 2022 MiTek Industries, Inc. Fri Jan 13 10:17:00
ID:3vyfz6tENv2hLUBccWHLJKy6LqX-RfC?PsB70Hq3NSgPqnL8w3UTxBGKWrCDoi7J4zJC7f

Page: 1

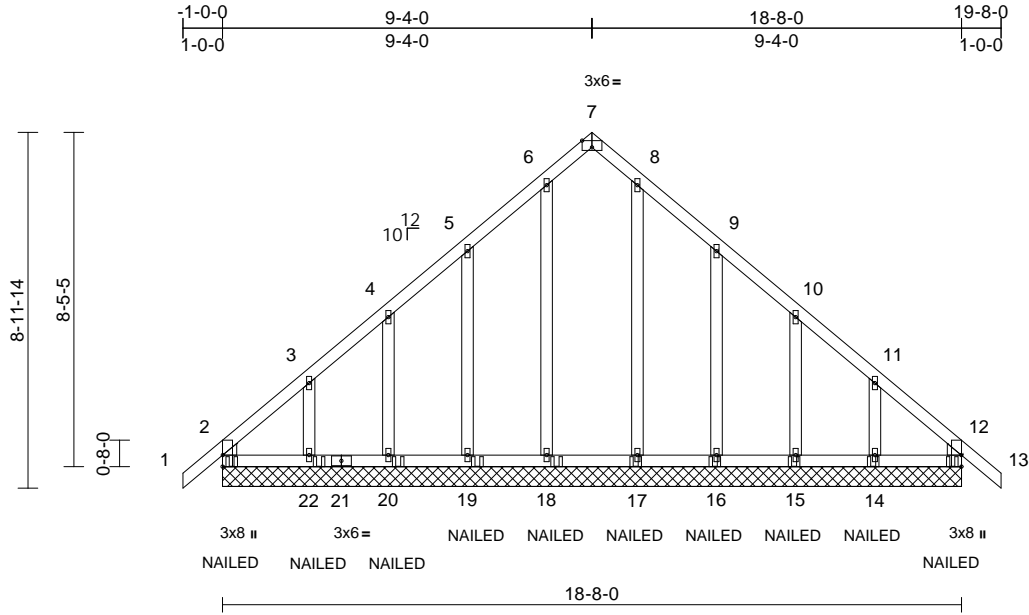

Scale = 1:58.2

Plate Offsets (X, Y): [2:Edge,0-0-1], [7:0-3-0,Edge], [12:Edge,0-0-1]

Loading	(psf)	Spacing	2-0-0	CSI	DEFL	in	(loc)	l/defl	L/d	PLATES	GRIP	
TCLL (roof)	20.0	Plate Grip DOL	1.15	TC	0.07	Vert(LL)	n/a	-	n/a	999	MT20	244/190
TCDL	10.0	Lumber DOL	1.15	BC	0.09	Vert(CT)	n/a	-	n/a	999		
BCLL	0.0*	Rep Stress Incr	YES	WB	0.10	Horz(CT)	0.01	12	n/a	n/a		
BCDL	10.0	Code	IRC2015/TPI2014	Matrix-MS							Weight: 122 lb	FT = 20%

LUMBER
TOP CHORD 2x4 SP No.2
BOT CHORD 2x4 SP No.2
OTHERS 2x4 SP No.3 *Except* 18-6,17-8:2x4 SP No.2
WEDGE Left: 2x4 SP No.3
Right: 2x4 SP No.3

BRACING
TOP CHORD Structural wood sheathing directly applied or 6-0-0 oc purlins.
BOT CHORD Rigid ceiling directly applied or 10-0-0 oc bracing.

REACTIONS (size)
2=18-8-0, 12=18-8-0, 14=18-8-0,
15=18-8-0, 16=18-8-0, 17=18-8-0,
18=18-8-0, 19=18-8-0, 20=18-8-0,
22=18-8-0, 23=18-8-0, 26=18-8-0
Max Horiz 2=-167 (LC 10), 23=-167 (LC 10)
Max Uplift 2=-32 (LC 8), 12=-16 (LC 9),
14=-127 (LC 13), 15=-64 (LC 13),
16=-101 (LC 13), 17=-11 (LC 13),
18=-22 (LC 12), 19=-98 (LC 12),
20=-64 (LC 12), 22=-129 (LC 12),
23=-32 (LC 8), 26=-16 (LC 9)
Max Grav 2=227 (LC 21), 12=219 (LC 22),
14=205 (LC 20), 15=211 (LC 20),
16=256 (LC 20), 17=230 (LC 20),
18=243 (LC 19), 19=252 (LC 19),
20=211 (LC 19), 22=208 (LC 19),
23=227 (LC 21), 26=219 (LC 22)

FORCES (lb) - Maximum Compression/Maximum Tension
TOP CHORD 1-2=0/38, 2-3=-212/137, 3-4=-137/78,
4-5=-100/57, 5-6=-88/58, 6-7=-71/56,
7-8=-71/56, 8-9=-73/44, 9-10=-88/36,
10-11=-123/74, 11-12=-197/140, 12-13=0/38

BOT CHORD 2-22=-125/192, 20-22=-125/192,
19-20=-125/192, 18-19=-125/192,
17-18=-125/192, 16-17=-125/192,
15-16=-125/192, 14-15=-125/192,
12-14=-125/192
WEBS 6-18=-115/24, 8-17=-105/12, 5-19=-138/93,
4-20=-125/71, 3-22=-144/97, 9-16=-138/96,
10-15=-125/71, 11-14=-144/96

NOTES

- Unbalanced roof live loads have been considered for this design.
- Wind: ASCE 7-10; Vult=115mph (3-second gust) Vasd=91mph; TCCL=6.0psf; BCDL=6.0psf; h=30ft; Cat. II; Exp B; Enclosed; MWFRS (envelope) exterior zone and C-C Corner (3) -1-0-0 to 3-6-6, Exterior (2) 3-6-6 to 9-4-0, Corner (3) 9-4-0 to 13-10-6, Exterior (2) 13-10-6 to 19-8-0 zone; cantilever left and right exposed; end vertical left and right exposed; C-C for members and forces & MWFRS for reactions shown; Lumber DOL=1.60 plate grip DOL=1.60
- Truss designed for wind loads in the plane of the truss only. For studs exposed to wind (normal to the face), see Standard Industry Gable End Details as applicable, or consult qualified building designer as per ANSI/TPI 1.
- All plates are 1.5x4 MT20 unless otherwise indicated.
- Gable requires continuous bottom chord bearing.
- Gable studs spaced at 2-0-0 oc.
- This truss has been designed for a 10.0 psf bottom chord live load nonconcurrent with any other live loads.
- * This truss has been designed for a live load of 20.0psf on the bottom chord in all areas where a rectangle 3-06-00 tall by 1-00-00 wide will fit between the bottom chord and any other members, with BCDL = 10.0psf.

- Provide mechanical connection (by others) of truss to bearing plate capable of withstanding 32 lb uplift at joint 2, 16 lb uplift at joint 12, 22 lb uplift at joint 18, 11 lb uplift at joint 17, 98 lb uplift at joint 19, 64 lb uplift at joint 20, 129 lb uplift at joint 22, 101 lb uplift at joint 16, 64 lb uplift at joint 15, 127 lb uplift at joint 14, 32 lb uplift at joint 2 and 16 lb uplift at joint 12.
- This truss is designed in accordance with the 2015 International Residential Code sections R502.11.1 and R802.10.2 and referenced standard ANSI/TPI 1.
- "NAILED" indicates 3-10d (0.148"x3") or 3-12d (0.148"x3.25") toe-nails per NDS guidelines.
- In the LOAD CASE(S) section, loads applied to the face of the truss are noted as front (F) or back (B).

LOAD CASE(S) Standard

- Dead + Roof Live (balanced): Lumber Increase=1.15, Plate Increase=1.15
Uniform Loads (lb/ft)
Vert: 1-7=-60, 7-13=-60, 23-26=-20
Concentrated Loads (lb)
Vert: 18=-32 (B), 17=-32 (B), 19=-32 (B), 20=-32 (B),
22=-32 (B), 16=-32 (B), 15=-32 (B), 14=-32 (B),
23=-40 (B), 26=-40 (B)



January 17, 2023

WARNING - Verify design parameters and READ NOTES ON THIS AND INCLUDED MITEK REFERENCE PAGE MII-7473 rev. 5/19/2020 BEFORE USE.

Design valid for use only with MiTek® connectors. This design is based only upon parameters shown, and is for an individual building component, not a truss system. Before use, the building designer must verify the applicability of design parameters and properly incorporate this design into the overall building design. Bracing indicated is to prevent buckling of individual truss web and/or chord members only. Additional temporary and permanent bracing is always required for stability and to prevent collapse with possible personal injury and property damage. For general guidance regarding the fabrication, storage, delivery, erection and bracing of trusses and truss systems, see **ANSI/TPI1 Quality Criteria, DSB-89 and BCSI Building Component Safety Information** available from Truss Plate Institute, 2670 Crain Highway, Suite 203 Waldorf, MD 20601



818 Soundside Road
Edenton, NC 27932

Job 36029A	Truss E2G	Truss Type Common Girder	Qty 1	Ply 2	57 SERENITY Job Reference (optional)	156131966
---------------	--------------	-----------------------------	----------	----------	---	-----------

84 Components (Dunn), Dunn, NC - 28334,

Run: 8.63 S Nov 19 2022 Print: 8.630 S Nov 19 2022 MiTek Industries, Inc. Fri Jan 13 10:17:01
ID:Boy7DpBkBBs10AAJuOYciVy6Lbw-RfC?PsB70Hq3NSgPqnL8w3uITXbGKWrCDoi7J4zJC?F

Page: 1

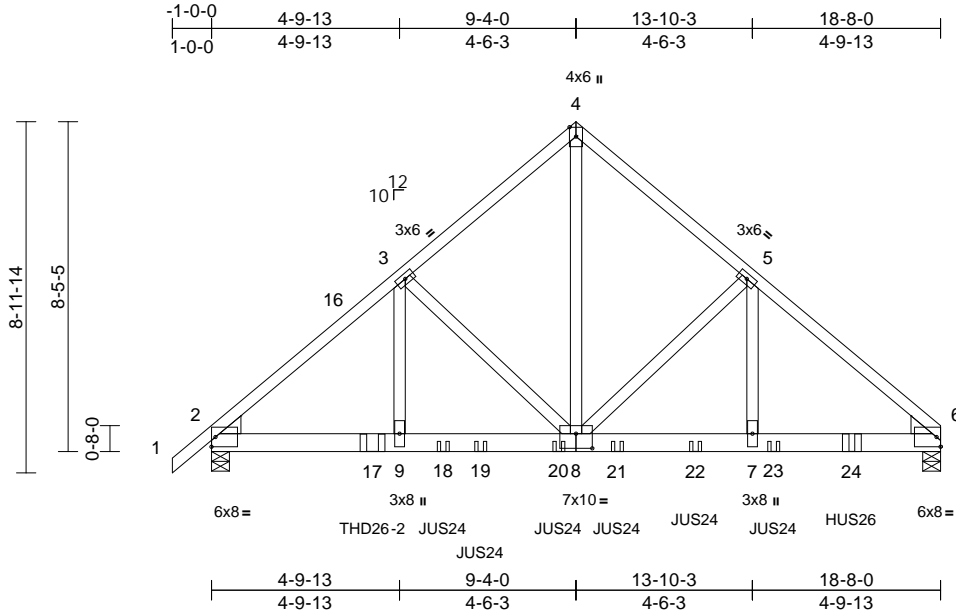

Scale = 1:59

Plate Offsets (X, Y): [8:0-5-0,0-4-8]

Loading	(psf)	Spacing	2-0-0	CSI	DEFL	in	(loc)	l/defl	L/d	PLATES	GRIP	
TCLL (roof)	20.0	Plate Grip DOL	1.15	TC	0.30	Vert(LL)	-0.06	8-9	>999	240	MT20	244/190
TCDL	10.0	Lumber DOL	1.15	BC	0.46	Vert(CT)	-0.11	8-9	>999	180		
BCLL	0.0*	Rep Stress Incr	NO	WB	0.45	Horz(CT)	0.02	6	n/a	n/a		
BCDL	10.0	Code	IRC2015/TPI2014	Matrix-MS								
											Weight: 251 lb	FT = 20%

LUMBER

TOP CHORD 2x4 SP No.2
 BOT CHORD 2x6 SP DSS
 WEBS 2x4 SP No.3 *Except* 8-4:2x4 SP No.2
 WEDGE Left: 2x6 SP No.2
 Right: 2x6 SP No.2

BRACING

TOP CHORD Structural wood sheathing directly applied or 5-7-3 oc purlins.
 BOT CHORD Rigid ceiling directly applied or 10-0-0 oc bracing.

REACTIONS

(size) 2=0-5-8, 6=0-5-8
 Max Horiz 2=161 (LC 9)
 Max Uplift 2=-355 (LC 12), 6=-289 (LC 13)
 Max Grav 2=3297 (LC 1), 6=4051 (LC 1)

FORCES

(lb) - Maximum Compression/Maximum Tension
 TOP CHORD 1-2=0/38, 2-3=-4486/523, 3-4=-3154/406, 4-5=-3160/411, 5-6=-4667/449
 BOT CHORD 2-9=-405/3363, 7-9=-405/3524, 6-7=-271/3524
 WEBS 3-9=-194/1555, 3-8=-1393/300, 4-8=-440/3659, 5-8=-1614/214, 5-7=-81/1786

NOTES

- 2-ply truss to be connected together with 10d (0.131"x3") nails as follows:
 Top chords connected as follows: 2x4 - 1 row at 0-9-0 oc.
 Bottom chords connected as follows: 2x6 - 2 rows staggered at 0-6-0 oc.
 Web connected as follows: 2x4 - 1 row at 0-9-0 oc.
- All loads are considered equally applied to all plies, except if noted as front (F) or back (B) face in the LOAD CASE(S) section. Ply to ply connections have been provided to distribute only loads noted as (F) or (B), unless otherwise indicated.
- Unbalanced roof live loads have been considered for this design.

- Wind: ASCE 7-10; Vult=115mph (3-second gust) Vasd=91mph; TC DL=6.0psf; BC DL=6.0psf; h=30ft; Cat. II; Exp B; Enclosed; MWFRS (envelope) exterior zone and C-C Exterior (2) 1-0-0 to 3-6-6, Interior (1) 3-6-6 to 9-4-0, Exterior (2) 9-4-0 to 13-10-3, Interior (1) 13-10-3 to 18-8-0 zone; cantilever left and right exposed; end vertical left and right exposed; C-C for members and forces & MWFRS for reactions shown; Lumber DOL=1.60 plate grip DOL=1.60
- This truss has been designed for a 10.0 psf bottom chord live load nonconcurrent with any other live loads.
- * This truss has been designed for a live load of 20.0psf on the bottom chord in all areas where a rectangle 3-06-00 tall by 1-00-00 wide will fit between the bottom chord and any other members.
- Provide mechanical connection (by others) of truss to bearing plate capable of withstanding 289 lb uplift at joint 6 and 355 lb uplift at joint 2.
- This truss is designed in accordance with the 2015 International Residential Code sections R502.11.1 and R802.10.2 and referenced standard ANSI/TPI 1.
- Use MiTek THD26-2 (With 18-16d nails into Girder & 12-10d nails into Truss) or equivalent at 4-1-8 from the left end to connect truss(es) to front face of bottom chord.
- Use MiTek JUS24 (With 4-10d nails into Girder & 2-10d nails into Truss) or equivalent spaced at 2-0-0 oc max. starting at 5-11-4 from the left end to 14-4-12 to connect truss(es) to front face of bottom chord.
- Use MiTek HUS26 (With 14-16d nails into Girder & 4-16d nails into Truss) or equivalent at 16-4-12 from the left end to connect truss(es) to front face of bottom chord.
- Fill all nail holes where hanger is in contact with lumber.

LOAD CASE(S) Standard

- Dead + Roof Live (balanced): Lumber Increase=1.15, Plate Increase=1.15
 Uniform Loads (lb/ft)
 Vert: 1-4=-60, 4-6=-60, 10-13=-20

Concentrated Loads (lb)

Vert: 17=-924 (F), 18=-580 (F), 19=-586 (F), 20=-532 (F), 21=-528 (F), 22=-528 (F), 23=-528 (F), 24=-1589 (F)



January 17, 2023

WARNING - Verify design parameters and READ NOTES ON THIS AND INCLUDED MITEK REFERENCE PAGE MII-7473 rev. 5/19/2020 BEFORE USE.

Design valid for use only with MiTek® connectors. This design is based only upon parameters shown, and is for an individual building component, not a truss system. Before use, the building designer must verify the applicability of design parameters and properly incorporate this design into the overall building design. Bracing indicated is to prevent buckling of individual truss web and/or chord members only. Additional temporary and permanent bracing is always required for stability and to prevent collapse with possible personal injury and property damage. For general guidance regarding the fabrication, storage, delivery, erection and bracing of trusses and truss systems, see ANSITPI Quality Criteria, DSB-89 and BCSI Building Component Safety Information available from Truss Plate Institute, 2670 Crain Highway, Suite 203 Waldorf, MD 20601



818 Soundside Road
 Edenton, NC 27932

Job 36029A	Truss FG1	Truss Type Flat Girder	Qty 1	Ply 2	57 SERENITY Job Reference (optional)	156131967
---------------	--------------	---------------------------	----------	----------	---	-----------

84 Components (Dunn), Dunn, NC - 28334,

Run: 8.63 S Nov 19 2022 Print: 8.630 S Nov 19 2022 MiTek Industries, Inc. Fri Jan 13 10:17:05
 ID:S:TjohRf8E5zdg7rGYHEKy6Llx-RfC?PsB70Hq3NSgPqnL8w3uITXbGKWRcDoi7J4zJc?f

Page: 1

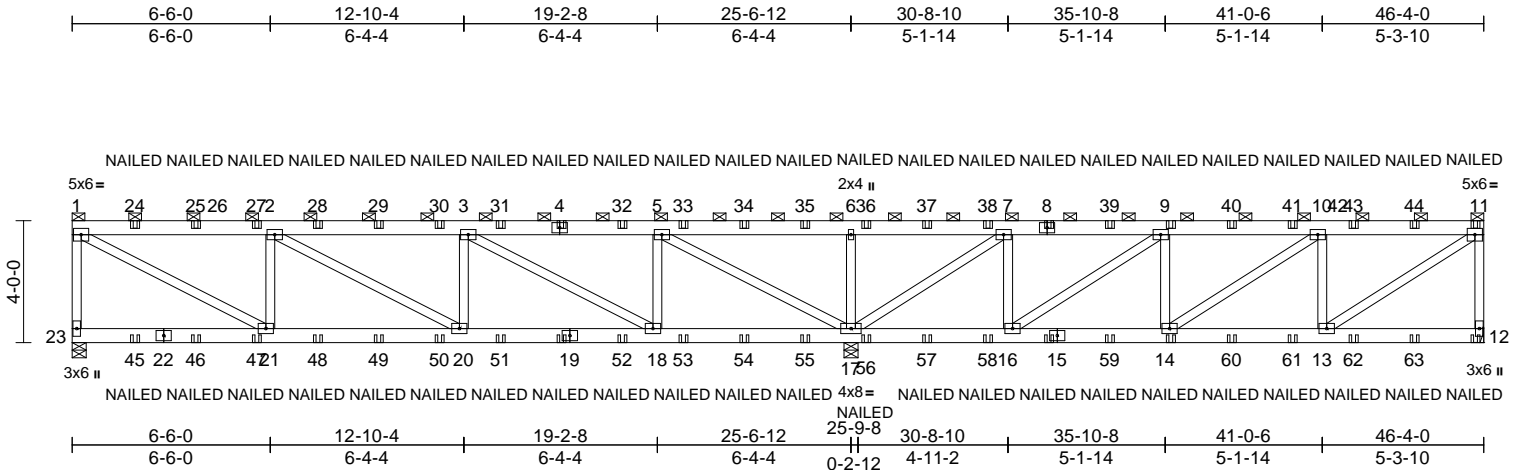

Scale = 1:75.6

Loading	(psf)	Spacing	2-0-0	CSI	DEFL	in	(loc)	l/defl	L/d	PLATES	GRIP	
TCLL (roof)	20.0	Plate Grip DOL	1.15	TC	0.32	Vert(LL)	0.04	20	>999	240	MT20	244/190
TCDL	10.0	Lumber DOL	1.15	BC	0.23	Vert(CT)	-0.08	20-21	>999	180		
BCLL	0.0*	Rep Stress Incr	NO	WB	0.52	Horz(CT)	0.02	12	n/a	n/a		
BCDL	10.0	Code	IRC2015/TPI2014	Matrix-MS								
											Weight: 665 lb	FT = 20%

LUMBER	
TOP CHORD	2x6 SP No.2
BOT CHORD	2x6 SP No.2
WEBS	2x4 SP No.3 *Except* 5-17,21-1,20-2,18-3:2x4 SP No.2
BRACING	
TOP CHORD	2-0-0 oc purlins (6-0-0 max.): 1-11, except end verticals.
BOT CHORD	Rigid ceiling directly applied or 10-0-0 oc bracing, Except: 6-0-0 oc bracing: 16-17.
REACTIONS	
(size)	12= Mechanical, 17=0-5-8, 23=0-5-8
Max Horiz	23=100 (LC 8)
Max Uplift	12=181 (LC 9), 17=626 (LC 9), 23=221 (LC 8)
Max Grav	12=944 (LC 1), 17=3202 (LC 1), 23=1180 (LC 1)
FORCES	
(lb) - Maximum Compression/Maximum Tension	
TOP CHORD	1-23=-1087/259, 1-2=-1621/320, 2-3=-1811/340, 3-5=-708/132, 5-6=-354/1624, 6-7=-354/1624, 7-9=-41/28, 9-10=-890/184, 10-11=-909/194, 11-12=-833/229
BOT CHORD	21-23=-92/120, 20-21=-364/1621, 18-20=-384/1811, 17-18=-153/708, 16-17=-37/64, 14-16=-180/890, 13-14=-189/909, 12-13=-27/50
WEBS	6-17=-512/241, 7-16=-23/750, 7-17=-1967/386, 9-16=-1084/212, 9-14=0/302, 10-14=-22/14, 10-13=-424/219, 11-13=-198/1081, 5-17=-2670/530, 2-21=-649/305, 1-21=-355/1821, 2-20=-49/218, 3-20=0/269, 3-18=-1263/264, 5-18=-4/814

- 2-ply truss to be connected together with 10d (0.131"x3") nails as follows:
Top chords connected as follows: 2x4 - 1 row at 0-9-0 oc, 2x6 - 2 rows staggered at 0-9-0 oc.
Bottom chords connected as follows: 2x6 - 2 rows staggered at 0-9-0 oc.
Web connected as follows: 2x4 - 1 row at 0-9-0 oc.
- All loads are considered equally applied to all plies, except if noted as front (F) or back (B) face in the LOAD CASE(S) section. Ply to ply connections have been provided to distribute only loads noted as (F) or (B), unless otherwise indicated.
- Wind: ASCE 7-10; Vult=115mph (3-second gust)
Vasd=91mph; TC DL=6.0psf; BCDL=6.0psf; h=30ft; Cat. II; Exp B; Enclosed; MWFRS (envelope) exterior zone and C-C Exterior (2) 0-1-12 to 4-9-6, Interior (1) 4-9-6 to 46-2-4 zone; cantilever left and right exposed; end vertical left and right exposed; C-C for members and forces & MWFRS for reactions shown; Lumber DOL=1.60 plate grip DOL=1.60
- Provide adequate drainage to prevent water ponding.
- All plates are 4x6 MT20 unless otherwise indicated.
- This truss has been designed for a 10.0 psf bottom chord live load nonconcurrent with any other live loads.
- * This truss has been designed for a live load of 20.0psf on the bottom chord in all areas where a rectangle 3-06-00 tall by 1-00-00 wide will fit between the bottom chord and any other members.
- Refer to girder(s) for truss to truss connections.
- Provide mechanical connection (by others) of truss to bearing plate capable of withstanding 221 lb uplift at joint 23, 181 lb uplift at joint 12 and 626 lb uplift at joint 17.
- This truss is designed in accordance with the 2015 International Residential Code sections R502.11.1 and R802.10.2 and referenced standard ANSI/TPI 1.
- Graphical purlin representation does not depict the size or the orientation of the purlin along the top and/or bottom chord.
- "NAILED" indicates 3-10d (0.148"x3") or 3-12d (0.148"x3.25") toe-nails per NDS guidelines.

- LOAD CASE(S)** Standard
- Dead + Roof Live (balanced): Lumber Increase=1.15, Plate Increase=1.15
Uniform Loads (lb/ft)
Vert: 1-11=-60, 12-23=-20
Concentrated Loads (lb)
Vert: 4=-38 (B), 11=-64 (B), 12=-41 (B), 9=-38 (B), 14=-32 (B), 8=-38 (B), 15=-32 (B), 19=-32 (B), 24=-38 (B), 25=-38 (B), 27=-38 (B), 28=-38 (B), 29=-38 (B), 30=-38 (B), 31=-38 (B), 32=-38 (B), 33=-38 (B), 34=-38 (B), 35=-38 (B), 36=-38 (B), 37=-38 (B), 38=-38 (B), 39=-38 (B), 40=-38 (B), 41=-38 (B), 43=-38 (B), 44=-38 (B), 45=-32 (B), 46=-32 (B), 47=-32 (B), 48=-32 (B), 49=-32 (B), 50=-32 (B), 51=-32 (B), 52=-32 (B), 53=-32 (B), 54=-32 (B), 55=-32 (B), 56=-32 (B), 57=-32 (B), 58=-32 (B), 59=-32 (B), 60=-32 (B), 61=-32 (B), 62=-32 (B), 63=-32 (B)

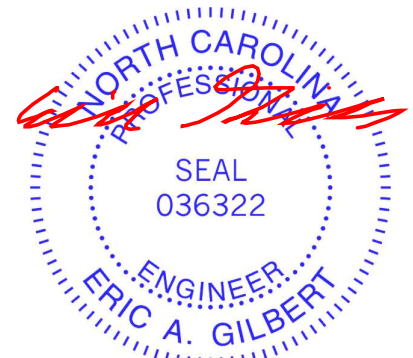

January 17, 2023

WARNING - Verify design parameters and READ NOTES ON THIS AND INCLUDED MITEK REFERENCE PAGE MII-7473 rev. 5/19/2020 BEFORE USE.

Design valid for use only with MiTek® connectors. This design is based only upon parameters shown, and is for an individual building component, not a truss system. Before use, the building designer must verify the applicability of design parameters and properly incorporate this design into the overall building design. Bracing indicated is to prevent buckling of individual truss web and/or chord members only. Additional temporary and permanent bracing is always required for stability and to prevent collapse with possible personal injury and property damage. For general guidance regarding the fabrication, storage, delivery, erection and bracing of trusses and truss systems, see ANSITPI Quality Criteria, DSB-89 and BCSI Building Component Safety Information available from Truss Plate Institute, 2670 Crain Highway, Suite 203 Waldorf, MD 20601

ENGINEERING BY
TRENCO
A MiTek Affiliate

818 Soundside Road
Edenton, NC 27932

Job 36029A	Truss H1	Truss Type Hip	Qty 1	Ply 1	57 SERENITY Job Reference (optional)	I56131968
---------------	-------------	-------------------	----------	----------	---	-----------

84 Components (Dunn), Dunn, NC - 28334,

Run: 8.63 S Nov 19 2022 Print: 8.630 S Nov 19 2022 MiTek Industries, Inc. Fri Jan 13 10:17:06
ID:QFT5X45i4kr93yZnQkPky6Lc2-RfC?PsB70Hq3NSgPqnL8w3ulTXbGKWRcDoi7J4zJC?f

Page: 1

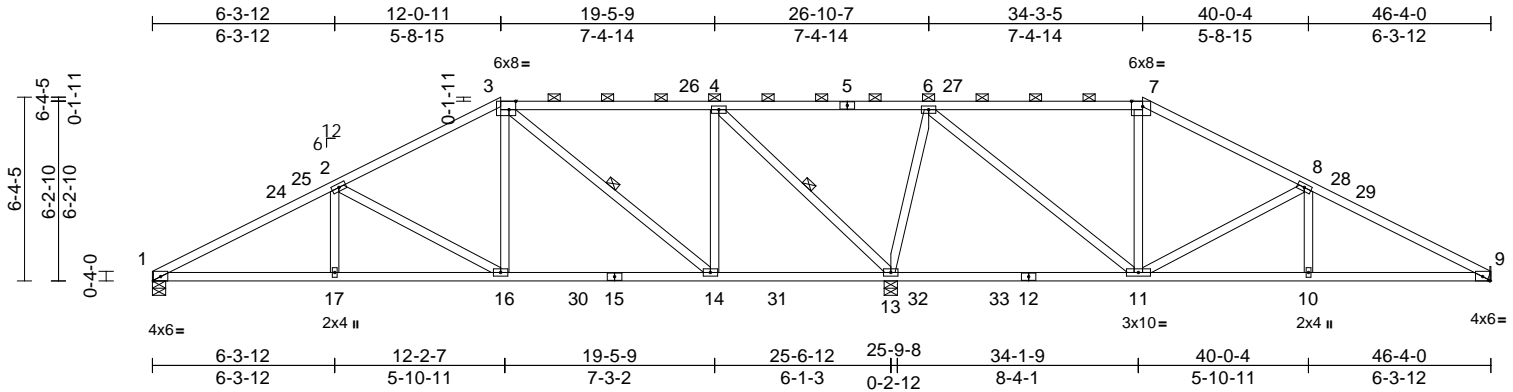

Scale = 1:79.8

Plate Offsets (X, Y): [3:0-2-12,Edge], [7:0-4-10,Edge]

Loading	(psf)	Spacing	2-0-0	CSI	DEFL	in	(loc)	l/defl	L/d	PLATES	GRIP	
TCLL (roof)	20.0	Plate Grip DOL	1.15	TC	0.88	Vert(LL)	-0.11	11-13	>999	240	MT20	244/190
TCDL	10.0	Lumber DOL	1.15	BC	0.59	Vert(CT)	-0.23	11-13	>999	180		
BCLL	0.0*	Rep Stress Incr	YES	WB	0.86	Horz(CT)	0.04	9	n/a	n/a		
BCDL	10.0	Code	IRC2015/TPI2014	Matrix-MS							Weight: 243 lb	FT = 20%

LUMBER

TOP CHORD 2x4 SP No.2
 BOT CHORD 2x4 SP No.2
 WEBS 2x4 SP No.3 *Except*
 16-2,14-3,13-4,11-6,11-8:2x4 SP No.2

BRACING

TOP CHORD Structural wood sheathing directly applied or 4-3-12 oc purlins, except 2-0-0 oc purlins (6-0-0 max.): 3-7.
 BOT CHORD Rigid ceiling directly applied or 10-0-0 oc bracing, Except: 6-0-0 oc bracing: 11-13.
 WEBS 1 Row at midpt 3-14, 4-13

REACTIONS

(size) 1=0-5-8, 9= Mechanical, 13=0-5-8
 Max Horiz 1=-78 (LC 13)
 Max Uplift 1=-31 (LC 12), 9=-52 (LC 13), 13=-27 (LC 9)
 Max Grav 1=838 (LC 23), 9=606 (LC 24), 13=2331 (LC 1)

FORCES

(lb) - Maximum Compression/Maximum Tension
 TOP CHORD 1-2=-1446/106, 2-3=-905/107, 3-4=-260/95, 4-6=0/892, 6-7=-272/112, 7-8=-389/98, 8-9=-934/113
 BOT CHORD 1-17=-73/1251, 16-17=-73/1251, 14-16=-9/750, 13-14=-42/258, 11-13=-638/111, 10-11=-39/794, 9-10=-39/794
 WEBS 2-17=0/250, 2-16=-583/118, 3-16=0/473, 3-14=-682/47, 4-14=0/587, 4-13=-1466/87, 6-13=-1178/145, 6-11=-51/1069, 7-11=-253/76, 8-11=-592/121, 8-10=0/241

NOTES

1) Unbalanced roof live loads have been considered for this design.

- 2) Wind: ASCE 7-10; Vult=115mph (3-second gust) Vasd=91mph; TC DL=6.0psf; BC DL=6.0psf; h=30ft; Cat. II; Exp B; Enclosed; MWFRS (envelope) exterior zone and C-C Exterior (2) 0-0-0 to 4-7-10, Interior (1) 4-7-10 to 12-0-11, Exterior (2) 12-0-11 to 18-7-5, Interior (1) 18-7-5 to 34-3-5, Exterior (2) 34-3-5 to 40-9-15, Interior (1) 40-9-15 to 46-4-0 zone; cantilever left and right exposed ; end vertical left and right exposed;C-C for members and forces & MWFRS for reactions shown; Lumber DOL=1.60 plate grip DOL=1.60
- 3) Provide adequate drainage to prevent water ponding.
- 4) All plates are 3x6 MT20 unless otherwise indicated.
- 5) This truss has been designed for a 10.0 psf bottom chord live load nonconcurrent with any other live loads.
- 6) * This truss has been designed for a live load of 20.0psf on the bottom chord in all areas where a rectangle 3-06-00 tall by 1-00-00 wide will fit between the bottom chord and any other members, with BCDL = 10.0psf.
- 7) Refer to girder(s) for truss to truss connections.
- 8) Provide mechanical connection (by others) of truss to bearing plate capable of withstanding 31 lb uplift at joint 1, 52 lb uplift at joint 9 and 27 lb uplift at joint 13.
- 9) This truss is designed in accordance with the 2015 International Residential Code sections R502.11.1 and R802.10.2 and referenced standard ANSI/TPI 1.
- 10) Graphical purlin representation does not depict the size or the orientation of the purlin along the top and/or bottom chord.

LOAD CASE(S) Standard



January 17, 2023

WARNING - Verify design parameters and READ NOTES ON THIS AND INCLUDED MITEK REFERENCE PAGE MII-7473 rev. 5/19/2020 BEFORE USE.

Design valid for use only with MiTek® connectors. This design is based only upon parameters shown, and is for an individual building component, not a truss system. Before use, the building designer must verify the applicability of design parameters and properly incorporate this design into the overall building design. Bracing indicated is to prevent buckling of individual truss web and/or chord members only. Additional temporary and permanent bracing is always required for stability and to prevent collapse with possible personal injury and property damage. For general guidance regarding the fabrication, storage, delivery, erection and bracing of trusses and truss systems, see **ANSI/TPI Quality Criteria, DSB-89 and BCSI Building Component Safety Information** available from Truss Plate Institute, 2670 Crain Highway, Suite 203 Waldorf, MD 20601



818 Soundside Road
 Edenton, NC 27932

Job 36029A	Truss H2	Truss Type Half Hip	Qty 1	Ply 1	57 SERENITY Job Reference (optional)	156131969
---------------	-------------	------------------------	----------	----------	---	-----------

84 Components (Dunn), Dunn, NC - 28334,

Run: 8.63 S Nov 19 2022 Print: 8.630 S Nov 19 2022 MiTek Industries, Inc. Fri Jan 13 10:17:07
ID:fgtnAonWO83TSAU6yPrxRwy6LUI-RfC?PsB70Hq3NSgPqnL8w3uITxBGKWrCDoi7J4zJC?f

Page: 1

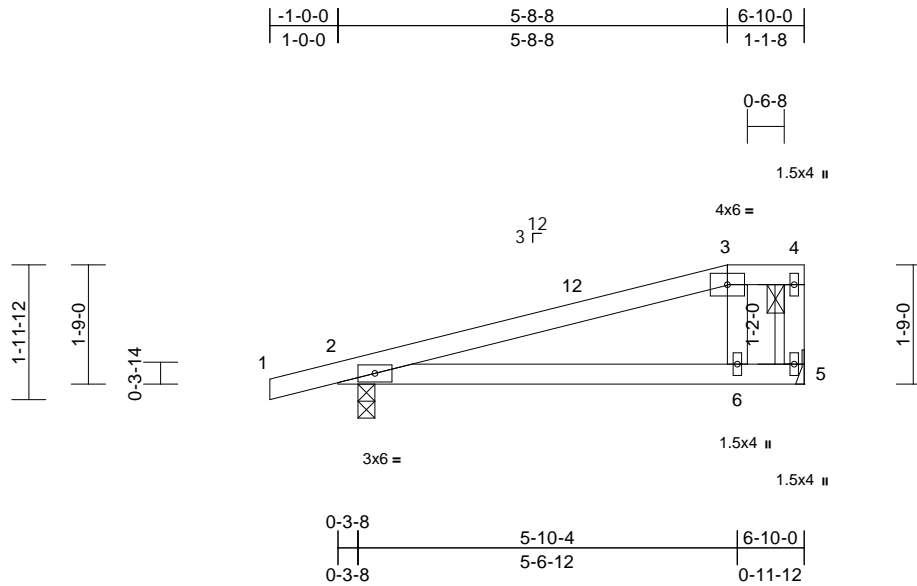

Loading	(psf)	Spacing	2-0-0	CSI	DEFL	in	(loc)	l/defl	L/d	PLATES	GRIP	
TCLL (roof)	20.0	Plate Grip DOL	1.15	TC	0.49	Vert(LL)	-0.08	6-11	>972	240	MT20	244/190
TCDL	10.0	Lumber DOL	1.15	BC	0.53	Vert(CT)	-0.19	6-11	>423	180		
BCLL	0.0*	Rep Stress Incr	YES	WB	0.04	Horz(CT)	0.00	2	n/a	n/a		
BCDL	10.0	Code	IRC2015/TPI2014	Matrix-MP							Weight: 26 lb	FT = 20%

LUMBER
 TOP CHORD 2x4 SP No.2
 BOT CHORD 2x4 SP No.2
 WEBS 2x4 SP No.3

BRACING
 TOP CHORD Structural wood sheathing directly applied or 6-0-0 oc purlins, except end verticals, and 2-0-0 oc purlins: 3-4.
 BOT CHORD Rigid ceiling directly applied or 10-0-0 oc bracing.

REACTIONS (size) 2=0-3-0, 5= Mechanical
 Max Horiz 2=50 (LC 11)
 Max Uplift 2=-51 (LC 8), 5=-19 (LC 8)
 Max Grav 2=347 (LC 1), 5=248 (LC 1)

FORCES (lb) - Maximum Compression/Maximum Tension
 TOP CHORD 1-2=0/15, 2-3=-113/78, 3-4=-20/22, 4-5=-29/16
 BOT CHORD 2-6=-84/89, 5-6=-20/22
 WEBS 3-6=-177/89

- NOTES**
- Unbalanced roof live loads have been considered for this design.
 - Wind: ASCE 7-10; Vult=115mph (3-second gust) Vasd=91mph; TCDL=6.0psf; BCDL=6.0psf; h=30ft; Cat. II; Exp B; Enclosed; MWFRS (envelope) exterior zone and C-C Exterior (2) 1-0-0 to 3-6-6, Interior (1) 3-6-6 to 5-8-8, Exterior (2) 5-8-8 to 6-8-4 zone; cantilever left and right exposed; end vertical left and right exposed; C-C for members and forces & MWFRS for reactions shown; Lumber DOL=1.60 plate grip DOL=1.60
 - Provide adequate drainage to prevent water ponding.
 - This truss has been designed for a 10.0 psf bottom chord live load nonconcurrent with any other live loads.
 - * This truss has been designed for a live load of 20.0psf on the bottom chord in all areas where a rectangle 3-06-00 tall by 1-00-00 wide will fit between the bottom chord and any other members.
 - Refer to girder(s) for truss to truss connections.

- Provide mechanical connection (by others) of truss to bearing plate capable of withstanding 19 lb uplift at joint 5 and 51 lb uplift at joint 2.
- This truss is designed in accordance with the 2015 International Residential Code sections R502.11.1 and R802.10.2 and referenced standard ANSI/TPI 1.
- Graphical purlin representation does not depict the size or the orientation of the purlin along the top and/or bottom chord.

LOAD CASE(S) Standard

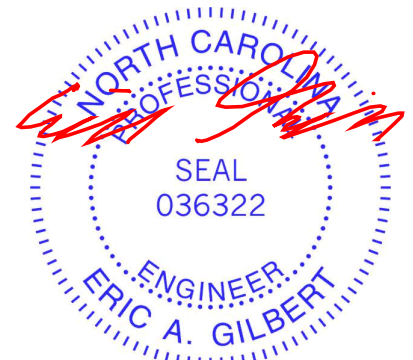

January 17, 2023

WARNING - Verify design parameters and READ NOTES ON THIS AND INCLUDED MITEK REFERENCE PAGE MII-7473 rev. 5/19/2020 BEFORE USE.

Design valid for use only with MiTek® connectors. This design is based only upon parameters shown, and is for an individual building component, not a truss system. Before use, the building designer must verify the applicability of design parameters and properly incorporate this design into the overall building design. Bracing indicated is to prevent buckling of individual truss web and/or chord members only. Additional temporary and permanent bracing is always required for stability and to prevent collapse with possible personal injury and property damage. For general guidance regarding the fabrication, storage, delivery, erection and bracing of trusses and truss systems, see **ANSI/TPI1 Quality Criteria, DSB-89 and BCSI Building Component Safety Information** available from Truss Plate Institute, 2670 Crain Highway, Suite 203 Waldorf, MD 20601



818 Soundside Road
 Edenton, NC 27932

Job 36029A	Truss H3G	Truss Type Half Hip Girder	Qty 1	Ply 1	57 SERENITY Job Reference (optional)	156131970
---------------	--------------	-------------------------------	----------	----------	---	-----------

84 Components (Dunn), Dunn, NC - 28334,

Run: 8.63 S Nov 19 2022 Print: 8.630 S Nov 19 2022 MiTek Industries, Inc. Fri Jan 13 10:17:07

Page: 1

ID:qn1xUYwQoWRvGtqD5DYXNFy6LUX-RfC?PsB70Hq3NSgPqnL8w3uITXbGKWRCDoi7J4zJC?f

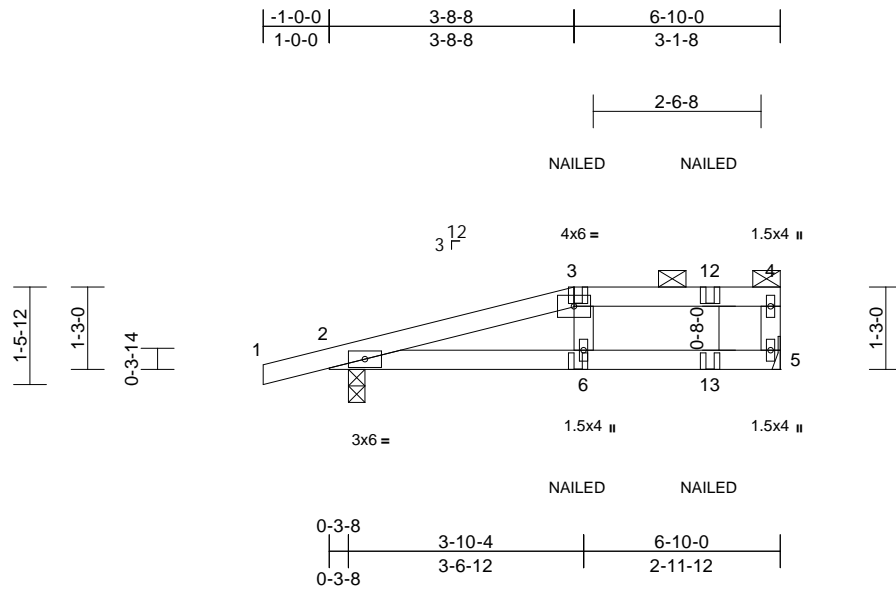

Scale = 1:34.9

Loading	(psf)	Spacing	2-0-0	CSI	DEFL	in	(loc)	l/defl	L/d	PLATES	GRIP	
TCLL (roof)	20.0	Plate Grip DOL	1.15	TC	0.44	Vert(LL)	-0.15	6-11	>536	240	MT20	244/190
TCDL	10.0	Lumber DOL	1.15	BC	0.97	Vert(CT)	-0.32	6-11	>250	180		
BCLL	0.0*	Rep Stress Incr	NO	WB	0.05	Horz(CT)	0.00	2	n/a	n/a		
BCDL	10.0	Code	IRC2015/TPI2014	Matrix-MP							Weight: 24 lb	FT = 20%

LUMBER

TOP CHORD 2x4 SP No.2
 BOT CHORD 2x4 SP No.1
 WEBS 2x4 SP No.3

BRACING

TOP CHORD Structural wood sheathing directly applied or 6-0-0 oc purlins, except end verticals, and 2-0-0 oc purlins: 3-4.
 BOT CHORD Rigid ceiling directly applied or 5-0-0 oc bracing.

REACTIONS

(size) 2=0-3-0, 5= Mechanical
 Max Horiz 2=34 (LC 11)
 Max Uplift 2=-50 (LC 8), 5=-10 (LC 8)
 Max Grav 2=382 (LC 1), 5=332 (LC 1)

FORCES

(lb) - Maximum Compression/Maximum Tension

TOP CHORD 1-2=0/15, 2-3=-143/77, 3-4=-13/14, 4-5=-111/44
 BOT CHORD 2-6=-85/110, 5-6=-13/14
 WEBS 3-6=-260/86

NOTES

- 1) Wind: ASCE 7-10; Vult=115mph (3-second gust) Vasd=91mph; TCCL=6.0psf; BCCL=6.0psf; h=30ft; Cat. II; Exp B; Enclosed; MWFRS (envelope) exterior zone and C-C Exterior (2) zone; cantilever left and right exposed; end vertical left and right exposed; C-C for members and forces & MWFRS for reactions shown; Lumber DOL=1.60 plate grip DOL=1.60
- 2) Provide adequate drainage to prevent water ponding.
- 3) This truss has been designed for a 10.0 psf bottom chord live load nonconcurrent with any other live loads.
- 4) * This truss has been designed for a live load of 20.0psf on the bottom chord in all areas where a rectangle 3-06-00 tall by 1-00-00 wide will fit between the bottom chord and any other members.
- 5) Refer to girder(s) for truss to truss connections.
- 6) Provide mechanical connection (by others) of truss to bearing plate capable of withstanding 10 lb uplift at joint 5 and 50 lb uplift at joint 2.

- 7) This truss is designed in accordance with the 2015 International Residential Code sections R502.11.1 and R802.10.2 and referenced standard ANSI/TPI 1.
- 8) Graphical purlin representation does not depict the size or the orientation of the purlin along the top and/or bottom chord.
- 9) "NAILED" indicates 3-10d (0.148"x3") or 3-12d (0.148"x3.25") toe-nails per NDS guidelines.
- 10) In the LOAD CASE(S) section, loads applied to the face of the truss are noted as front (F) or back (B).

LOAD CASE(S) Standard

- 1) Dead + Roof Live (balanced): Lumber Increase=1.15, Plate Increase=1.15
 Uniform Loads (lb/ft)
 Vert: 1-3=-60, 3-4=-60, 5-7=-20
 Concentrated Loads (lb)
 Vert: 3=-28 (F), 6=-29 (F), 12=-31 (F), 13=-30 (F)

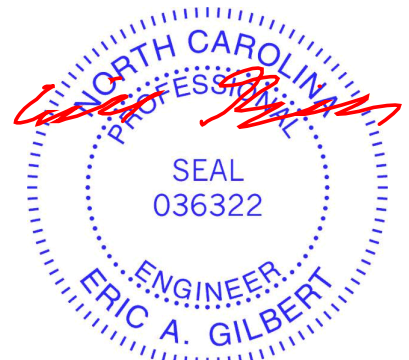

January 17, 2023

WARNING - Verify design parameters and READ NOTES ON THIS AND INCLUDED MITEK REFERENCE PAGE MII-7473 rev. 5/19/2020 BEFORE USE.

Design valid for use only with MiTek® connectors. This design is based only upon parameters shown, and is for an individual building component, not a truss system. Before use, the building designer must verify the applicability of design parameters and properly incorporate this design into the overall building design. Bracing indicated is to prevent buckling of individual truss web and/or chord members only. Additional temporary and permanent bracing is always required for stability and to prevent collapse with possible personal injury and property damage. For general guidance regarding the fabrication, storage, delivery, erection and bracing of trusses and truss systems, see **ANSI/TPI1 Quality Criteria, DSB-89 and BCSI Building Component Safety Information** available from Truss Plate Institute, 2670 Crain Highway, Suite 203 Waldorf, MD 20601



818 Soundside Road
 Edenton, NC 27932

Job 36029A	Truss H4	Truss Type Flat	Qty 1	Ply 1	57 SERENITY Job Reference (optional)	I56131971
---------------	-------------	--------------------	----------	----------	---	-----------

84 Components (Dunn), Dunn, NC - 28334,

Run: 8.63 S Nov 19 2022 Print: 8.630 S Nov 19 2022 MiTek Industries, Inc. Fri Jan 13 10:17:08
ID:HSLt8Lh5t8OHRdibeP6a?Cy5wMH-RfC?PsB70Hq3NSgPqnL8w3uITXbGKWrCDoi7J4zJC?f

Page: 1

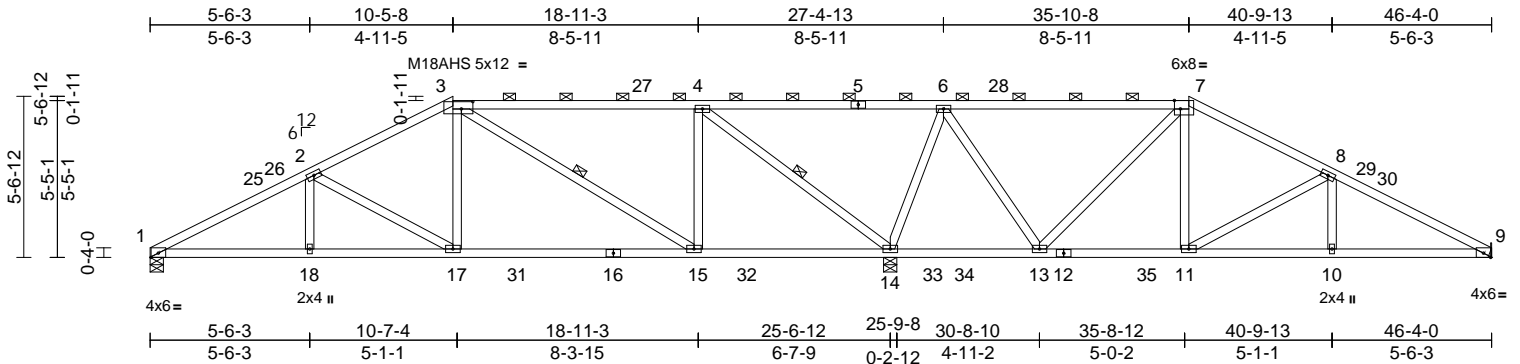

Scale = 1:79.6

Plate Offsets (X, Y): [3:0-4-12,0-3-0], [7:0-2-8,Edge]

Loading	(psf)	Spacing	2-0-0	CSI	DEFL	in	(loc)	l/defl	L/d	PLATES	GRIP	
TCLL (roof)	20.0	Plate Grip DOL	1.15	TC	0.81	Vert(LL)	-0.11	15-17	>999	240	MT20	244/190
TCDL	10.0	Lumber DOL	1.15	BC	0.59	Vert(CT)	-0.25	15-17	>999	180	M18AHS	186/179
BCLL	0.0*	Rep Stress Incr	YES	WB	0.74	Horz(CT)	0.04	9	n/a	n/a		
BCDL	10.0	Code	IRC2015/TPI2014	Matrix-MS							Weight: 240 lb	FT = 20%

LUMBER

TOP CHORD 2x4 SP No.2 *Except* 3-5-5:7:2x4 SP No.1
 BOT CHORD 2x4 SP No.2
 WEBS 2x4 SP No.3 *Except* 15-3,14-4,13-7:2x4 SP No.2

BRACING

TOP CHORD Structural wood sheathing directly applied or 4-4-12 oc purlins, except 2-0-0 oc purlins (6-0-0 max.): 3-7.
 BOT CHORD Rigid ceiling directly applied or 10-0-0 oc bracing, Except: 6-0-0 oc bracing: 13-14.
 WEBS 1 Row at midpt 3-15, 4-14

REACTIONS

(size) 1=0-5-8, 9= Mechanical, 14=0-5-8
 Max Horiz 1=67 (LC 16)
 Max Uplift 1=-23 (LC 12), 9=-43 (LC 13), 14=65 (LC 9)
 Max Grav 1=835 (LC 23), 9=600 (LC 24), 14=2325 (LC 1)

FORCES

(lb) - Maximum Compression/Maximum Tension
 TOP CHORD 1-2=-1477/112, 2-3=-1039/103, 3-4=-387/91, 4-6=0/1032, 6-7=0/215, 7-8=-500/86, 8-9=-966/91
 BOT CHORD 1-18=-63/1284, 17-18=-63/1284, 15-17=-13/886, 14-15=-45/385, 13-14=-609/102, 11-13=0/400, 10-11=-30/827, 9-10=-30/827
 WEBS 2-18=0/195, 2-17=-466/106, 3-17=0/446, 3-15=-634/49, 4-15=0/577, 4-14=-1679/94, 6-14=-1252/132, 6-13=0/759, 7-13=-762/78, 7-11=0/378, 8-11=-499/96, 8-10=0/229

NOTES

1) Unbalanced roof live loads have been considered for this design.

- 2) Wind: ASCE 7-10; Vult=115mph (3-second gust) Vasd=91mph; TC DL=6.0psf; BCDL=6.0psf; h=30ft; Cat. II; Exp B; Enclosed; MWFRS (envelope) exterior zone and C-C Exterior (2) 0-0-0 to 4-7-10, Interior (1) 4-7-10 to 10-5-8, Exterior (2) 10-5-8 to 17-0-2, Interior (1) 17-0-2 to 35-10-8, Exterior (2) 35-10-8 to 42-5-2, Interior (1) 42-5-2 to 46-4-0 zone; cantilever left and right exposed; end vertical left and right exposed; C-C for members and forces & MWFRS for reactions shown; Lumber DOL=1.60 plate grip DOL=1.60
- 3) Provide adequate drainage to prevent water ponding.
- 4) All plates are MT20 plates unless otherwise indicated.
- 5) All plates are 3x6 MT20 unless otherwise indicated.
- 6) This truss has been designed for a 10.0 psf bottom chord live load nonconcurrent with any other live loads.
- 7) * This truss has been designed for a live load of 20.0psf on the bottom chord in all areas where a rectangle 3-06-00 tall by 1-00-00 wide will fit between the bottom chord and any other members, with BCDL = 10.0psf.
- 8) Refer to girder(s) for truss to truss connections.
- 9) Provide mechanical connection (by others) of truss to bearing plate capable of withstanding 23 lb uplift at joint 1, 43 lb uplift at joint 9 and 65 lb uplift at joint 14.
- 10) This truss is designed in accordance with the 2015 International Residential Code sections R502.11.1 and R802.10.2 and referenced standard ANSI/TPI 1.
- 11) Graphical purlin representation does not depict the size or the orientation of the purlin along the top and/or bottom chord.

LOAD CASE(S) Standard

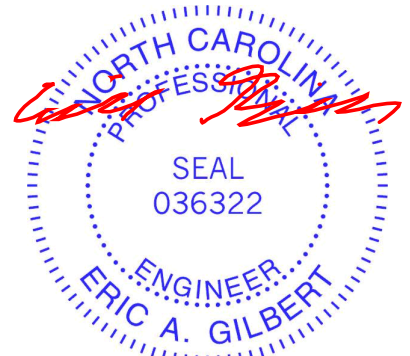

January 17, 2023

WARNING - Verify design parameters and READ NOTES ON THIS AND INCLUDED MITEK REFERENCE PAGE MII-7473 rev. 5/19/2020 BEFORE USE.

Design valid for use only with MiTek® connectors. This design is based only upon parameters shown, and is for an individual building component, not a truss system. Before use, the building designer must verify the applicability of design parameters and properly incorporate this design into the overall building design. Bracing indicated is to prevent buckling of individual truss web and/or chord members only. Additional temporary and permanent bracing is always required for stability and to prevent collapse with possible personal injury and property damage. For general guidance regarding the fabrication, storage, delivery, erection and bracing of trusses and truss systems, see **ANSI/TPI Quality Criteria, DSB-89 and BCSI Building Component Safety Information** available from Truss Plate Institute, 2670 Crain Highway, Suite 203 Waldorf, MD 20601



818 Soundside Road
Edenton, NC 27932

Job 36029A	Truss J2	Truss Type Jack-Open	Qty 23	Ply 1	57 SERENITY Job Reference (optional)	156131973
---------------	-------------	-------------------------	-----------	----------	---	-----------

84 Components (Dunn), Dunn, NC - 28334,

Run: 8.63 S Nov 19 2022 Print: 8.630 S Nov 19 2022 MiTek Industries, Inc. Fri Jan 13 10:17:08
ID:XTqjWjUthj?i9vygcFrRmKy5wQQ-RfC?PsB70Hq3NSgPqnL8w3uITXbGKWrCDoi7J4zJC?f

Page: 1

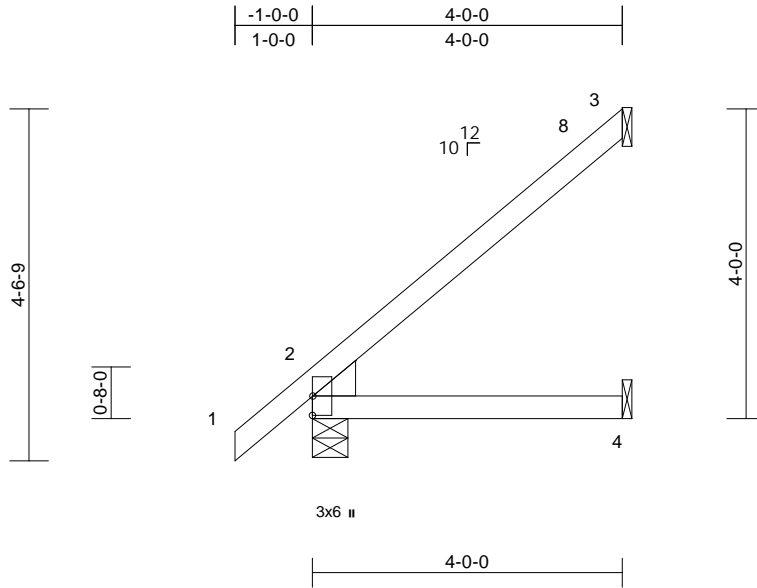

Scale = 1:29.7

Loading	(psf)	Spacing	2-0-0	CSI	DEFL	in	(loc)	l/defl	L/d	PLATES	GRIP	
TCLL (roof)	20.0	Plate Grip DOL	1.15	TC	0.20	Vert(LL)	0.02	4-7	>999	240	MT20	244/190
TCDL	10.0	Lumber DOL	1.15	BC	0.18	Vert(CT)	-0.03	4-7	>999	180		
BCLL	0.0*	Rep Stress Incr	YES	WB	0.00	Horz(CT)	0.01	3	n/a	n/a		
BCDL	10.0	Code	IRC2015/TPI2014	Matrix-MP							Weight: 17 lb	FT = 20%

LUMBER

TOP CHORD 2x4 SP No.2
BOT CHORD 2x4 SP No.2
WEDGE Left: 2x6 SP No.2

6) This truss is designed in accordance with the 2015 International Residential Code sections R502.11.1 and R802.10.2 and referenced standard ANSI/TPI 1.

LOAD CASE(S) Standard

BRACING

TOP CHORD Structural wood sheathing directly applied or 4-0-0 oc purlins.
BOT CHORD Rigid ceiling directly applied or 10-0-0 oc bracing.

REACTIONS (size) 2=0-5-8, 3= Mechanical, 4= Mechanical
Max Horiz 2=121 (LC 12)
Max Uplift 3=-62 (LC 12)
Max Grav 2=225 (LC 1), 3=105 (LC 19), 4=73 (LC 3)

FORCES (lb) - Maximum Compression/Maximum Tension

TOP CHORD 1-2=0/38, 2-3=-92/67
BOT CHORD 2-4=-80/92

NOTES

- 1) Wind: ASCE 7-10; Vult=115mph (3-second gust) Vasd=91mph; TCDL=6.0psf; BCDL=6.0psf; h=30ft; Cat. II; Exp B; Enclosed; MWFRS (envelope) exterior zone and C-C Exterior (2) -1-0-0 to 3-6-6, Interior (1) 3-6-6 to 3-11-4 zone; cantilever left and right exposed; end vertical left and right exposed; C-C for members and forces & MWFRS for reactions shown; Lumber DOL=1.60 plate grip DOL=1.60
- 2) This truss has been designed for a 10.0 psf bottom chord live load nonconcurrent with any other live loads.
- 3) * This truss has been designed for a live load of 20.0psf on the bottom chord in all areas where a rectangle 3-06-00 tall by 1-00-00 wide will fit between the bottom chord and any other members.
- 4) Refer to girder(s) for truss to truss connections.
- 5) Provide mechanical connection (by others) of truss to bearing plate capable of withstanding 62 lb uplift at joint 3.



January 17, 2023

WARNING - Verify design parameters and READ NOTES ON THIS AND INCLUDED MITEK REFERENCE PAGE MII-7473 rev. 5/19/2020 BEFORE USE.

Design valid for use only with MiTek® connectors. This design is based only upon parameters shown, and is for an individual building component, not a truss system. Before use, the building designer must verify the applicability of design parameters and properly incorporate this design into the overall building design. Bracing indicated is to prevent buckling of individual truss web and/or chord members only. Additional temporary and permanent bracing is always required for stability and to prevent collapse with possible personal injury and property damage. For general guidance regarding the fabrication, storage, delivery, erection and bracing of trusses and truss systems, see **ANSI/TPI1 Quality Criteria, DSB-89 and BCSI Building Component**

Safety Information available from Truss Plate Institute, 2670 Crain Highway, Suite 203 Waldorf, MD 20601

ENGINEERING BY
TRENCO
A MiTek Affiliate

818 Soundside Road
Edenton, NC 27932

Job 36029A	Truss J3	Truss Type Jack-Open Structural Gable	Qty 2	Ply 1	57 SERENITY Job Reference (optional)	156131974
---------------	-------------	--	----------	----------	---	-----------

84 Components (Dunn), Dunn, NC - 28334,

Run: 8.63 S Nov 19 2022 Print: 8.630 S Nov 19 2022 MiTek Industries, Inc. Fri Jan 13 10:17:09
ID:bjPHmmsccbwwqkKcQ3pm6n7y6LqY-RfC?PsB70Hq3NSgPqnL8w3ulTXbGKWrCDoi7J4zJC?f

Page: 1

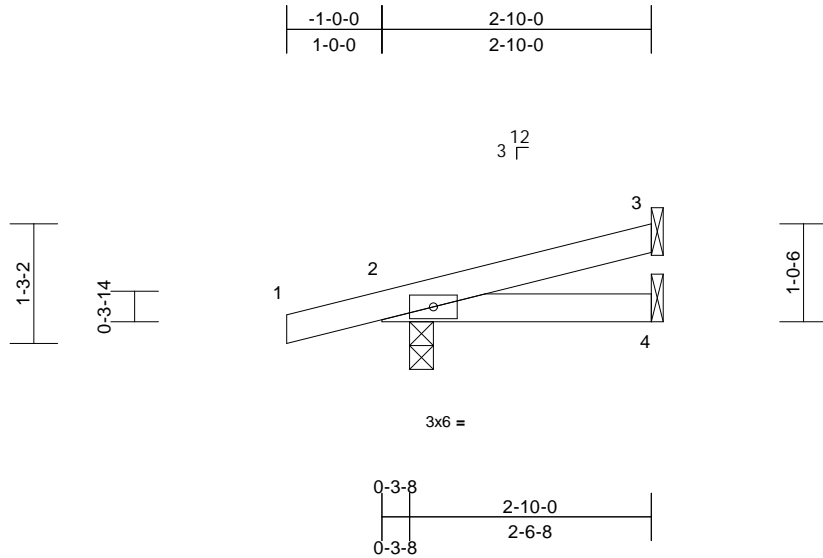

Scale = 1:24.2

Loading	(psf)	Spacing	2-0-0	CSI	DEFL	in	(loc)	l/defl	L/d	PLATES	GRIP	
TCLL (roof)	20.0	Plate Grip DOL	1.15	TC	0.07	Vert(LL)	0.00	4-9	>999	240	MT20	244/190
TCDL	10.0	Lumber DOL	1.15	BC	0.06	Vert(CT)	0.00	4-9	>999	180		
BCLL	0.0*	Rep Stress Incr	YES	WB	0.00	Horz(CT)	0.00	3	n/a	n/a		
BCDL	10.0	Code	IRC2015/TPI2014	Matrix-MP							Weight: 10 lb	FT = 20%

LUMBER

TOP CHORD 2x4 SP No.2
BOT CHORD 2x4 SP No.2

7) This truss is designed in accordance with the 2015 International Residential Code sections R502.11.1 and R802.10.2 and referenced standard ANSI/TPI 1.

BRACING

TOP CHORD Structural wood sheathing directly applied or 2-10-0 oc purlins.
BOT CHORD Rigid ceiling directly applied or 10-0-0 oc bracing.

LOAD CASE(S) Standard

REACTIONS

(size) 2=0-3-0, 3= Mechanical, 4= Mechanical
Max Horiz 2=31 (LC 8)
Max Uplift 2=-44 (LC 8), 3=-14 (LC 12)
Max Grav 2=203 (LC 1), 3=52 (LC 1), 4=40 (LC 3)

FORCES

(lb) - Maximum Compression/Maximum Tension

TOP CHORD 1-2=0/15, 2-3=-51/81
BOT CHORD 2-4=-87/71

NOTES

- 1) Wind: ASCE 7-10; Vult=115mph (3-second gust)
Vasd=91mph; TC DL=6.0psf; BC DL=6.0psf; h=30ft; Cat. II; Exp B; Enclosed; MWFRS (envelope) exterior zone and C-C Exterior (2) zone; cantilever left and right exposed; end vertical left and right exposed; C-C for members and forces & MWFRS for reactions shown; Lumber DOL=1.60 plate grip DOL=1.60
- 2) This truss has been designed for a 10.0 psf bottom chord live load nonconcurrent with any other live loads.
- 3) * This truss has been designed for a live load of 20.0psf on the bottom chord in all areas where a rectangle 3-06-00 tall by 1-00-00 wide will fit between the bottom chord and any other members.
- 4) Refer to girder(s) for truss to truss connections.
- 5) Provide mechanical connection (by others) of truss to bearing plate at joint(s) 2.
- 6) Provide mechanical connection (by others) of truss to bearing plate capable of withstanding 14 lb uplift at joint 3 and 44 lb uplift at joint 2.



January 17, 2023

WARNING - Verify design parameters and READ NOTES ON THIS AND INCLUDED MITEK REFERENCE PAGE MII-7473 rev. 5/19/2020 BEFORE USE.

Design valid for use only with MiTek® connectors. This design is based only upon parameters shown, and is for an individual building component, not a truss system. Before use, the building designer must verify the applicability of design parameters and properly incorporate this design into the overall building design. Bracing indicated is to prevent buckling of individual truss web and/or chord members only. Additional temporary and permanent bracing is always required for stability and to prevent collapse with possible personal injury and property damage. For general guidance regarding the fabrication, storage, delivery, erection and bracing of trusses and truss systems, see **ANSI/TPI1 Quality Criteria, DSB-89 and BCSI Building Component Safety Information** available from Truss Plate Institute, 2670 Crain Highway, Suite 203 Waldorf, MD 20601



818 Soundside Road
Edenton, NC 27932

Job 36029A	Truss J4	Truss Type Jack-Open Structural Gable	Qty 8	Ply 1	57 SERENITY Job Reference (optional)	156131975
---------------	-------------	--	----------	----------	---	-----------

84 Components (Dunn), Dunn, NC - 28334,

Run: 8.63 S Nov 19 2022 Print: 8.630 S Nov 19 2022 MiTek Industries, Inc. Fri Jan 13 10:17:09
ID:bjPHmmscbwqkKcQ3pm6n7y6LqY-RfC?PsB70Hq3NSgPqnL8w3ulTXbGKWrCDoi7J4zJC?f

Page: 1

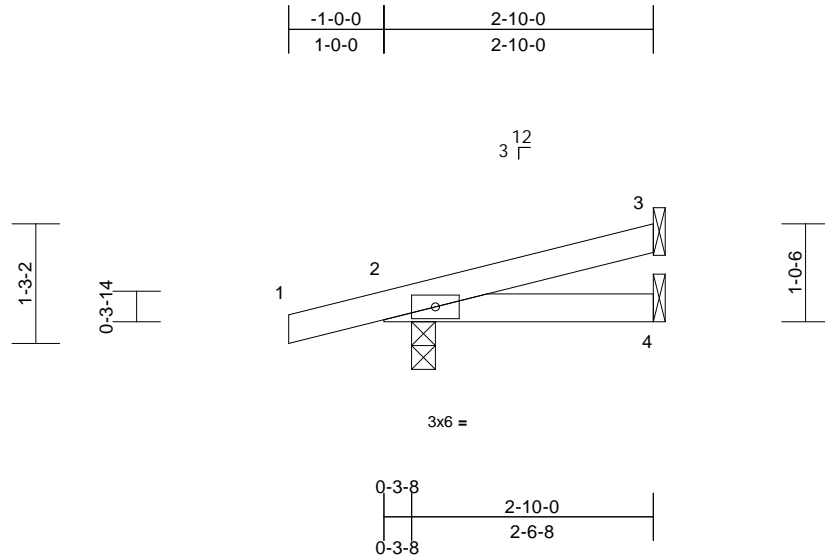

Scale = 1:24.2

Loading	(psf)	Spacing	2-0-0	CSI	DEFL	in	(loc)	l/defl	L/d	PLATES	GRIP	
TCLL (roof)	20.0	Plate Grip DOL	1.15	TC	0.07	Vert(LL)	0.00	4-9	>999	240	MT20	244/190
TCDL	10.0	Lumber DOL	1.15	BC	0.06	Vert(CT)	0.00	4-9	>999	180		
BCLL	0.0*	Rep Stress Incr	YES	WB	0.00	Horz(CT)	0.00	3	n/a	n/a		
BCDL	10.0	Code	IRC2015/TPI2014	Matrix-MP							Weight: 10 lb	FT = 20%

LUMBER
TOP CHORD 2x4 SP No.2
BOT CHORD 2x4 SP No.2

7) This truss is designed in accordance with the 2015 International Residential Code sections R502.11.1 and R802.10.2 and referenced standard ANSI/TPI 1.

BRACING
TOP CHORD Structural wood sheathing directly applied or 2-10-0 oc purlins.
BOT CHORD Rigid ceiling directly applied or 10-0-0 oc bracing.

LOAD CASE(S) Standard

REACTIONS (size) 2=0-3-0, 3= Mechanical, 4= Mechanical
Max Horiz 2=31 (LC 8)
Max Uplift 2=-44 (LC 8), 3=-14 (LC 12)
Max Grav 2=203 (LC 1), 3=52 (LC 1), 4=40 (LC 3)

FORCES (lb) - Maximum Compression/Maximum Tension
TOP CHORD 1-2=0/15, 2-3=-51/81
BOT CHORD 2-4=-87/71

- NOTES**
- 1) Wind: ASCE 7-10; Vult=115mph (3-second gust) Vasd=91mph; TC DL=6.0psf; BC DL=6.0psf; h=30ft; Cat. II; Exp B; Enclosed; MWFRS (envelope) exterior zone and C-C Exterior (2) zone; cantilever left and right exposed; end vertical left and right exposed; C-C for members and forces & MWFRS for reactions shown; Lumber DOL=1.60 plate grip DOL=1.60
 - 2) This truss has been designed for a 10.0 psf bottom chord live load nonconcurrent with any other live loads.
 - 3) * This truss has been designed for a live load of 20.0psf on the bottom chord in all areas where a rectangle 3-06-00 tall by 1-00-00 wide will fit between the bottom chord and any other members.
 - 4) Refer to girder(s) for truss to truss connections.
 - 5) Provide mechanical connection (by others) of truss to bearing plate at joint(s) 2.
 - 6) Provide mechanical connection (by others) of truss to bearing plate capable of withstanding 14 lb uplift at joint 3 and 44 lb uplift at joint 2.

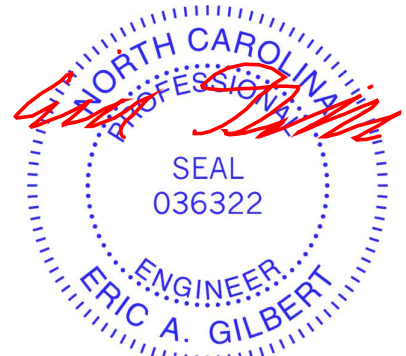

January 17, 2023

WARNING - Verify design parameters and READ NOTES ON THIS AND INCLUDED MITEK REFERENCE PAGE MII-7473 rev. 5/19/2020 BEFORE USE.

Design valid for use only with MiTek® connectors. This design is based only upon parameters shown, and is for an individual building component, not a truss system. Before use, the building designer must verify the applicability of design parameters and properly incorporate this design into the overall building design. Bracing indicated is to prevent buckling of individual truss web and/or chord members only. Additional temporary and permanent bracing is always required for stability and to prevent collapse with possible personal injury and property damage. For general guidance regarding the fabrication, storage, delivery, erection and bracing of trusses and truss systems, see **ANSI/TPI1 Quality Criteria, DSB-89 and BCSI Building Component**

Safety Information available from Truss Plate Institute, 2670 Crain Highway, Suite 203 Waldorf, MD 20601

ENGINEERING BY
TRENCO
A MiTek Affiliate

818 Soundside Road
Edenton, NC 27932

Job 36029A	Truss J5	Truss Type Jack-Open	Qty 2	Ply 1	57 SERENITY Job Reference (optional)	156131976
---------------	-------------	-------------------------	----------	----------	---	-----------

84 Components (Dunn), Dunn, NC - 28334,

Run: 8.63 S Nov 19 2022 Print: 8.630 S Nov 19 2022 MiTek Industries, Inc. Fri Jan 13 10:17:09
ID:MbTZHCvo1CJ2ejF1XW0lr1y6LUY-RfC?PsB70Hq3NSgPqnL8w3ulTXbGKWrCDoi7J4zJC?f

Page: 1

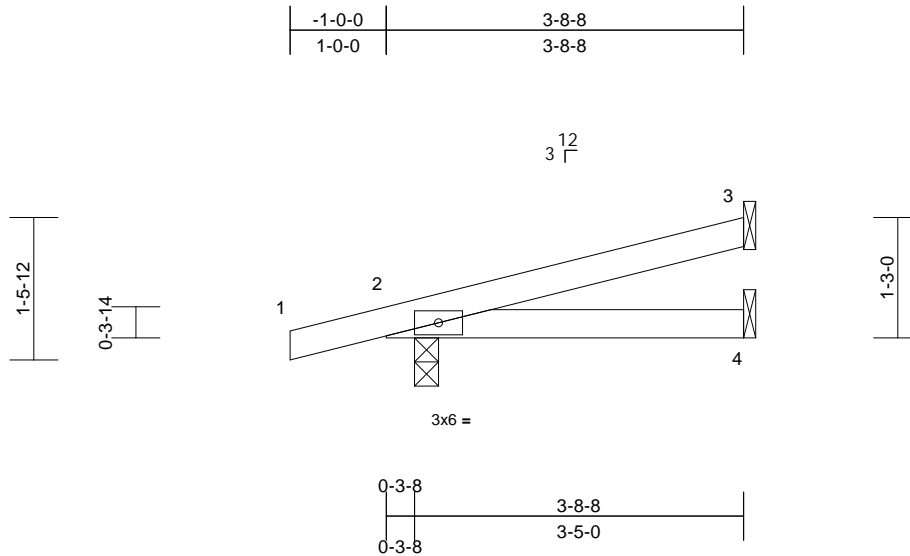

Loading	(psf)	Spacing	2-0-0	CSI	DEFL	in	(loc)	l/defl	L/d	PLATES	GRIP	
TCLL (roof)	20.0	Plate Grip DOL	1.15	TC	0.15	Vert(LL)	-0.01	4-7	>999	240	MT20	244/190
TCDL	10.0	Lumber DOL	1.15	BC	0.15	Vert(CT)	-0.02	4-7	>999	180		
BCLL	0.0*	Rep Stress Incr	YES	WB	0.00	Horz(CT)	0.00	2	n/a	n/a		
BCDL	10.0	Code	IRC2015/TPI2014	Matrix-MP							Weight: 13 lb	FT = 20%

LUMBER **LOAD CASE(S)** Standard

TOP CHORD 2x4 SP No.2
BOT CHORD 2x4 SP No.2

BRACING
TOP CHORD Structural wood sheathing directly applied or 3-8-8 oc purlins.
BOT CHORD Rigid ceiling directly applied or 10-0-0 oc bracing.

REACTIONS (size) 2=0-3-0, 3= Mechanical, 4= Mechanical
Max Horiz 2=38 (LC 8)
Max Uplift 2=-40 (LC 8), 3=-22 (LC 12)
Max Grav 2=214 (LC 1), 3=88 (LC 1), 4=63 (LC 3)

FORCES (lb) - Maximum Compression/Maximum Tension
TOP CHORD 1-2=0/15, 2-3=-78/18
BOT CHORD 2-4=-18/68

- NOTES**
- 1) Wind: ASCE 7-10; Vult=115mph (3-second gust) Vasd=91mph; TC DL=6.0psf; BC DL=6.0psf; h=30ft; Cat. II; Exp B; Enclosed; MWFRS (envelope) exterior zone and C-C Exterior (2) zone; cantilever left and right exposed; end vertical left and right exposed; C-C for members and forces & MWFRS for reactions shown; Lumber DOL=1.60 plate grip DOL=1.60
 - 2) This truss has been designed for a 10.0 psf bottom chord live load nonconcurrent with any other live loads.
 - 3) * This truss has been designed for a live load of 20.0psf on the bottom chord in all areas where a rectangle 3-06-00 tall by 1-00-00 wide will fit between the bottom chord and any other members.
 - 4) Refer to girder(s) for truss to truss connections.
 - 5) Provide mechanical connection (by others) of truss to bearing plate capable of withstanding 22 lb uplift at joint 3 and 40 lb uplift at joint 2.
 - 6) This truss is designed in accordance with the 2015 International Residential Code sections R502.11.1 and R802.10.2 and referenced standard ANSI/TPI 1.



January 17, 2023

WARNING - Verify design parameters and READ NOTES ON THIS AND INCLUDED MITEK REFERENCE PAGE MII-7473 rev. 5/19/2020 BEFORE USE.
Design valid for use only with MiTek® connectors. This design is based only upon parameters shown, and is for an individual building component, not a truss system. Before use, the building designer must verify the applicability of design parameters and properly incorporate this design into the overall building design. Bracing indicated is to prevent buckling of individual truss web and/or chord members only. Additional temporary and permanent bracing is always required for stability and to prevent collapse with possible personal injury and property damage. For general guidance regarding the fabrication, storage, delivery, erection and bracing of trusses and truss systems, see **ANSI/TPI1 Quality Criteria, DSB-89 and BCSI Building Component Safety Information** available from Truss Plate Institute, 2670 Crain Highway, Suite 203 Waldorf, MD 20601



818 Soundside Road
Edenton, NC 27932

Job 36029A	Truss M1	Truss Type Monopitch	Qty 3	Ply 1	57 SERENITY Job Reference (optional)	156131977
---------------	-------------	-------------------------	----------	----------	---	-----------

84 Components (Dunn), Dunn, NC - 28334,

Run: 8.63 S Nov 19 2022 Print: 8.630 S Nov 19 2022 MiTek Industries, Inc. Fri Jan 13 10:17:10
ID:q714P7THF2pZnfaU7BHidYy6LOfRfC?PsB70Hq3NSgPqnL8w3uITXhGKwRCDoi7J4zJC?f

Page: 1

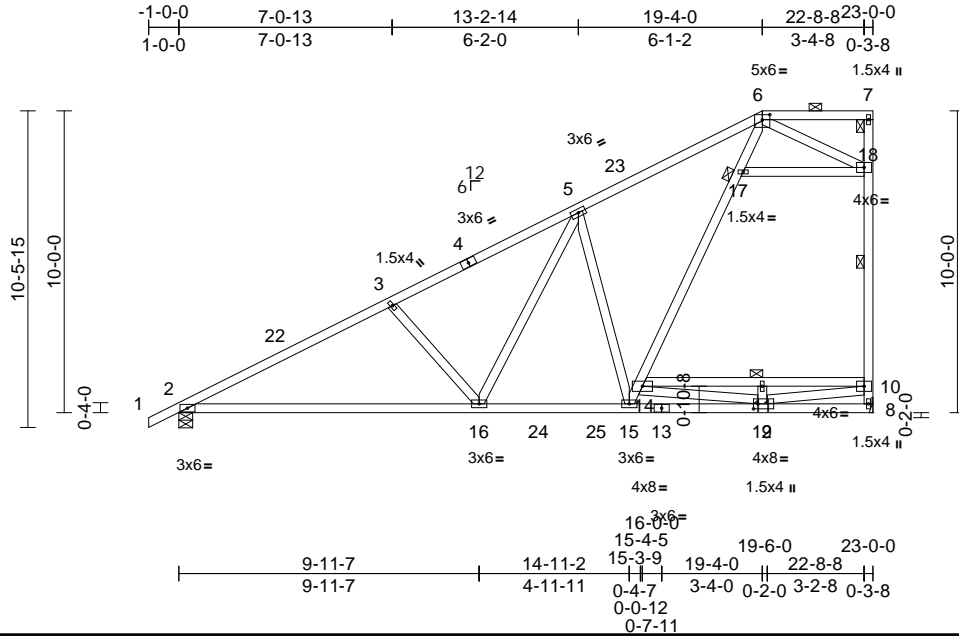

Loading	(psf)	Spacing	2-0-0	CSI	DEFL	in	(loc)	l/defl	L/d	PLATES	GRIP	
TCLL (roof)	20.0	Plate Grip DOL	1.15	TC	0.93	Vert(LL)	-0.24	15-16	>999	240	MT20	244/190
TCDL	10.0	Lumber DOL	1.15	BC	0.37	Vert(CT)	-0.48	16-21	>566	180		
BCLL	0.0*	Rep Stress Incr	YES	WB	0.90	Horz(CT)	0.02	8	n/a	n/a		
BCDL	10.0	Code	IRC2015/TPI2014	Matrix-MS							Weight: 164 lb	FT = 20%

LUMBER
TOP CHORD 2x4 SP No.1 *Except* 4-6:2x4 SP No.2
BOT CHORD 2x4 SP DSS *Except* 14-10:2x4 SP No.2 or 2x4 SPF No.2
WEBS 2x4 SP No.3 *Except* 5-16, 15-5:2x4 SP No.2, 15-6, 7-8:2x4 SP DSS

BRACING
TOP CHORD Structural wood sheathing directly applied or 4-3-1 oc purlins, except end verticals, and 2-0-0 oc purlins (10-0-0 max.): 6-7.
BOT CHORD Rigid ceiling directly applied or 10-0-0 oc bracing, Except:
6-0-0 oc bracing: 8-9,
6-0-0 oc bracing: 10-14
WEBS 1 Row at midpt 7-8
JOINTS 1 Brace at Jt(s): 7, 17

REACTIONS
(size) 2=0-5-8, 8= Mechanical
Max Horiz 2=306 (LC 11)
Max Uplift 2=-36 (LC 12)
Max Grav 2=1000 (LC 1), 8=1037 (LC 1)

FORCES
(lb) - Maximum Compression/Maximum Tension
TOP CHORD 1-2=0/27, 2-3=-1563/59, 3-5=-1316/58, 5-6=-829/114, 6-7=-61/370, 8-10=-1024/77, 10-18=-690/88, 7-18=-121/33
BOT CHORD 2-16=-193/1352, 15-16=-143/835, 12-15=-210/852, 9-12=0/792, 8-9=-692/236, 11-14=-653/0, 10-11=-657/0
WEBS 5-16=-25/601, 5-15=-754/175, 3-16=-388/147, 14-15=-112/515, 14-17=-67/800, 6-17=-56/614, 17-18=-105/517, 6-18=-1213/172, 11-12=-103/0, 9-10=-66/1293, 12-14=-374/391

- 2) Wind: ASCE 7-10; Vult=115mph (3-second gust) Vasd=91mph; TC DL=6.0psf; BC DL=6.0psf; h=30ft; Cat. II; Exp B; Enclosed; MWFRS (envelope) exterior zone and C-C Exterior (2) -1-0-0 to 3-6-6, Interior (1) 3-6-6 to 19-4-0, Exterior (2) 19-4-0 to 22-10-4 zone; cantilever left and right exposed; end vertical left and right exposed; C-C for members and forces & MWFRS for reactions shown; Lumber DOL=1.60 plate grip DOL=1.60
- 3) Provide adequate drainage to prevent water ponding.
- 4) This truss has been designed for a 10.0 psf bottom chord live load nonconcurrent with any other live loads.
- 5) * This truss has been designed for a live load of 20.0psf on the bottom chord in all areas where a rectangle 3-06-00 tall by 1-00-00 wide will fit between the bottom chord and any other members, with BCDL = 10.0psf.
- 6) Refer to girder(s) for truss to truss connections.
- 7) Provide mechanical connection (by others) of truss to bearing plate capable of withstanding 36 lb uplift at joint 2.
- 8) This truss is designed in accordance with the 2015 International Residential Code sections R502.11.1 and R802.10.2 and referenced standard ANSI/TPI 1.
- 9) Graphical purlin representation does not depict the size or the orientation of the purlin along the top and/or bottom chord.

LOAD CASE(S) Standard

NOTES
1) Unbalanced roof live loads have been considered for this design.

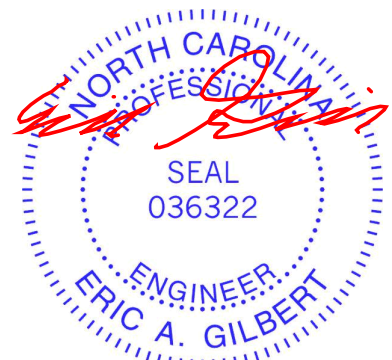

January 17, 2023

Job 36029A	Truss M2	Truss Type Monopitch Structural Gable	Qty 1	Ply 1	57 SERENITY Job Reference (optional)	156131978
---------------	-------------	--	----------	----------	---	-----------

84 Components (Dunn), Dunn, NC - 28334,

Run: 8.63 S Nov 19 2022 Print: 8.630 S Nov 19 2022 MiTek Industries, Inc. Fri Jan 13 10:17:10
ID:fYenD_liq6jleBqvzWC52Oy6LOI-RfC?PsB70Hq3NSgPqnL8w3uITxBGKWrCDoi7J4zJC?f

Page: 1

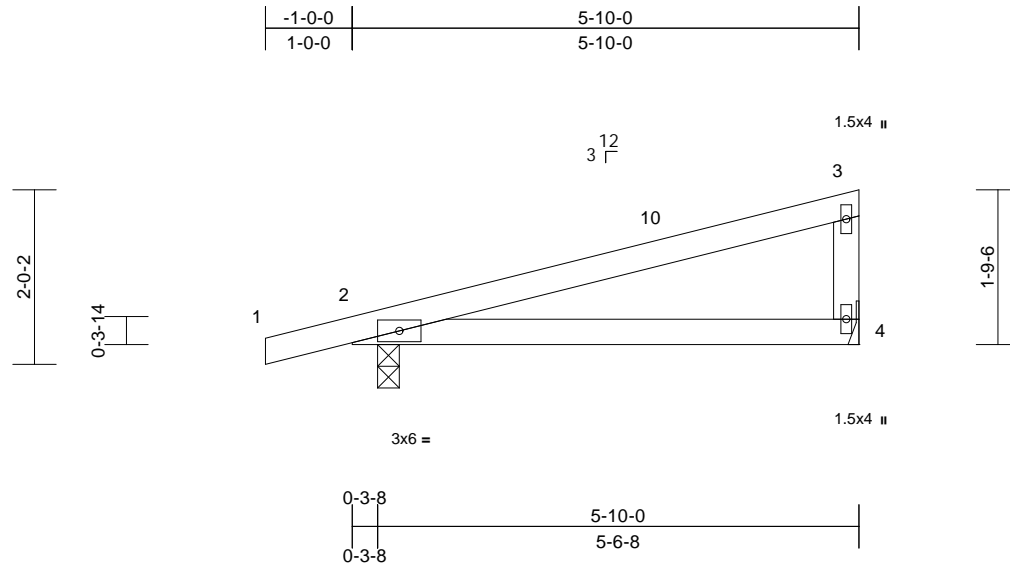

Scale = 1:26.5

Loading	(psf)	Spacing	2-0-0	CSI	DEFL	in	(loc)	l/defl	L/d	PLATES	GRIP	
TCLL (roof)	20.0	Plate Grip DOL	1.15	TC	0.41	Vert(LL)	-0.03	4-9	>999	240	MT20	244/190
TCDL	10.0	Lumber DOL	1.15	BC	0.32	Vert(CT)	-0.08	4-9	>837	180		
BCLL	0.0*	Rep Stress Incr	YES	WB	0.00	Horz(CT)	0.00	2	n/a	n/a		
BCDL	10.0	Code	IRC2015/TPI2014	Matrix-MP							Weight: 21 lb	FT = 20%

LUMBER

TOP CHORD 2x4 SP No.2
BOT CHORD 2x4 SP No.2
WEBS 2x4 SP No.3

LOAD CASE(S) Standard

BRACING

TOP CHORD Structural wood sheathing directly applied or 5-10-0 oc purlins, except end verticals.
BOT CHORD Rigid ceiling directly applied or 10-0-0 oc bracing.

REACTIONS (size) 2=0-3-0, 4= Mechanical

Max Horiz 2=50 (LC 11)
Max Uplift 2=-49 (LC 8), 4=-18 (LC 12)
Max Grav 2=309 (LC 1), 4=206 (LC 1)

FORCES (lb) - Maximum Compression/Maximum Tension

TOP CHORD 1-2=0/15, 2-3=-88/79, 3-4=-138/76
BOT CHORD 2-4=-85/74

NOTES

- 1) Wind: ASCE 7-10; Vult=115mph (3-second gust)
Vasd=91mph; TCDL=6.0psf; BCDL=6.0psf; h=30ft; Cat. II; Exp B; Enclosed; MWFRS (envelope) exterior zone and C-C Exterior (2) -1-0-0 to 3-6-6, Interior (1) 3-6-6 to 5-8-4 zone; cantilever left and right exposed; end vertical left and right exposed; C-C for members and forces & MWFRS for reactions shown; Lumber DOL=1.60 plate grip DOL=1.60
- 2) This truss has been designed for a 10.0 psf bottom chord live load nonconcurrent with any other live loads.
- 3) * This truss has been designed for a live load of 20.0psf on the bottom chord in all areas where a rectangle 3-06-00 tall by 1-00-00 wide will fit between the bottom chord and any other members.
- 4) Refer to girder(s) for truss to truss connections.
- 5) Provide mechanical connection (by others) of truss to bearing plate capable of withstanding 18 lb uplift at joint 4 and 49 lb uplift at joint 2.
- 6) This truss is designed in accordance with the 2015 International Residential Code sections R502.11.1 and R802.10.2 and referenced standard ANSI/TPI 1.

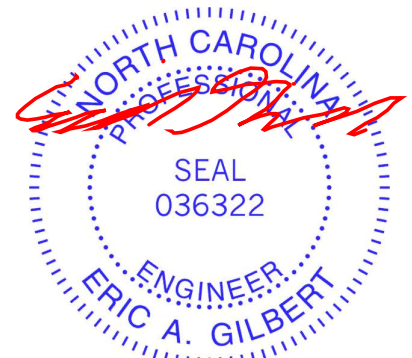

January 17, 2023

WARNING - Verify design parameters and READ NOTES ON THIS AND INCLUDED MITEK REFERENCE PAGE MII-7473 rev. 5/19/2020 BEFORE USE.

Design valid for use only with MiTek® connectors. This design is based only upon parameters shown, and is for an individual building component, not a truss system. Before use, the building designer must verify the applicability of design parameters and properly incorporate this design into the overall building design. Bracing indicated is to prevent buckling of individual truss web and/or chord members only. Additional temporary and permanent bracing is always required for stability and to prevent collapse with possible personal injury and property damage. For general guidance regarding the fabrication, storage, delivery, erection and bracing of trusses and truss systems, see

ANSI/TPI1 Quality Criteria, DSB-89 and BCSI Building Component

Safety Information available from Truss Plate Institute, 2670 Crain Highway, Suite 203 Waldorf, MD 20601



818 Soundside Road
Edenton, NC 27932

Job 36029A	Truss M3	Truss Type Monopitch Structural Gable	Qty 8	Ply 1	57 SERENITY Job Reference (optional)	156131979
---------------	-------------	--	----------	----------	---	-----------

84 Components (Dunn), Dunn, NC - 28334,

Run: 8.63 S Nov 19 2022 Print: 8.630 S Nov 19 2022 MiTek Industries, Inc. Fri Jan 13 10:17:10
ID:yuZQhNq5BFblzGsFtUqkqsy6LOB-RfC?PsB70Hq3NSgPqnL8w3uITXbGKWrCDoi7J4zJC?f

Page: 1

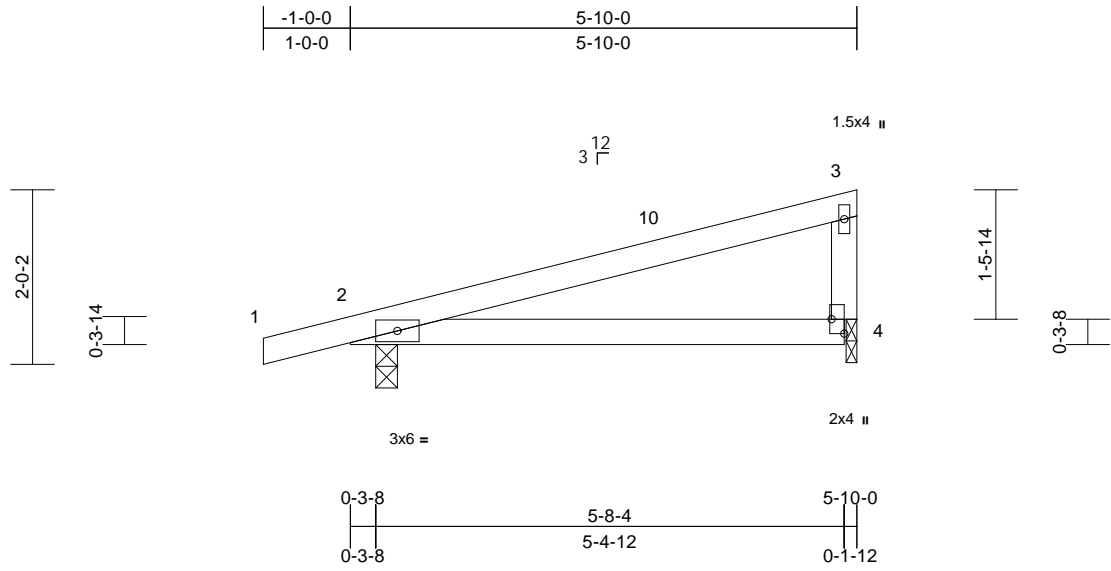

Scale = 1:26.5

Plate Offsets (X, Y): [4:Edge,0-1-12]

Loading	(psf)	Spacing	2-0-0	CSI	DEFL	in	(loc)	l/defl	L/d	PLATES	GRIP	
TCLL (roof)	20.0	Plate Grip DOL	1.15	TC	0.41	Vert(LL)	-0.03	4-9	>999	240	MT20	244/190
TCDL	10.0	Lumber DOL	1.15	BC	0.32	Vert(CT)	-0.08	4-9	>837	180		
BCLL	0.0*	Rep Stress Incr	YES	WB	0.00	Horz(CT)	0.00	2	n/a	n/a		
BCDL	10.0	Code	IRC2015/TPI2014	Matrix-MP							Weight: 21 lb	FT = 20%

LUMBER
TOP CHORD 2x4 SP No.2
BOT CHORD 2x4 SP No.2
WEBS 2x4 SP No.3

BRACING
TOP CHORD Structural wood sheathing directly applied or 5-10-0 oc purlins, except end verticals.
BOT CHORD Rigid ceiling directly applied or 10-0-0 oc bracing.

REACTIONS (size) 2=0-3-0, 4=0-1-8
Max Horiz 2=50 (LC 11)
Max Uplift 2=-49 (LC 8), 4=-18 (LC 12)
Max Grav 2=309 (LC 1), 4=206 (LC 1)

FORCES (lb) - Maximum Compression/Maximum Tension
TOP CHORD 1-2=0/15, 2-3=-88/79, 3-4=-138/76
BOT CHORD 2-4=-85/74

- NOTES**
- 1) Wind: ASCE 7-10; Vult=115mph (3-second gust) Vasd=91mph; TCDL=6.0psf; BCDL=6.0psf; h=30ft; Cat. II; Exp B; Enclosed; MWFRS (envelope) exterior zone and C-C Exterior (2) -1-0-0 to 3-6-6, Interior (1) 3-6-6 to 5-8-4 zone; cantilever left and right exposed; end vertical left and right exposed; C-C for members and forces & MWFRS for reactions shown; Lumber DOL=1.60 plate grip DOL=1.60
 - 2) This truss has been designed for a 10.0 psf bottom chord live load nonconcurrent with any other live loads.
 - 3) * This truss has been designed for a live load of 20.0psf on the bottom chord in all areas where a rectangle 3-06-00 tall by 1-00-00 wide will fit between the bottom chord and any other members.
 - 4) Bearing at joint(s) 4 considers parallel to grain value using ANSI/TPI 1 angle to grain formula. Building designer should verify capacity of bearing surface.
 - 5) Provide mechanical connection (by others) of truss to bearing plate at joint(s) 4.

- 6) Provide mechanical connection (by others) of truss to bearing plate capable of withstanding 49 lb uplift at joint 2 and 18 lb uplift at joint 4.
 - 7) This truss is designed in accordance with the 2015 International Residential Code sections R502.11.1 and R802.10.2 and referenced standard ANSI/TPI 1.
- LOAD CASE(S)** Standard



January 17, 2023

Job 36029A	Truss M4	Truss Type Monopitch	Qty 1	Ply 1	57 SERENITY Job Reference (optional)	156131980
---------------	-------------	-------------------------	----------	----------	---	-----------

84 Components (Dunn), Dunn, NC - 28334,

Run: 8.63 S Nov 19 2022 Print: 8.630 S Nov 19 2022 MiTek Industries, Inc. Fri Jan 13 10:17:11
ID:WbNIDi5MUwPpE?KyoNnuBkzvowA-RfC?PsB70Hq3NSgPqnL8w3uITXbGKWrCDoi7J4zJC?f

Page: 1

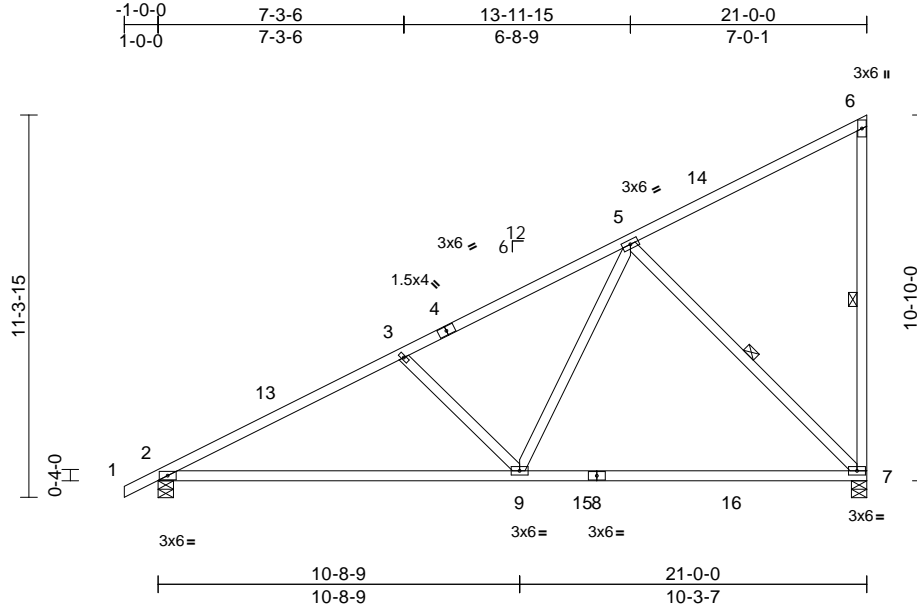

Scale = 1:68.3

Loading	(psf)	Spacing	2-0-0	CSI	DEFL	in	(loc)	l/defl	L/d	PLATES	GRIP	
TCLL (roof)	20.0	Plate Grip DOL	1.15	TC	0.65	Vert(LL)	-0.45	7-9	>562	240	MT20	244/190
TCDL	10.0	Lumber DOL	1.15	BC	0.86	Vert(CT)	-0.68	7-9	>369	180		
BCLL	0.0*	Rep Stress Incr	YES	WB	0.36	Horz(CT)	0.03	7	n/a	n/a		
BCDL	10.0	Code	IRC2015/TPI2014	Matrix-MS								Weight: 116 lb FT = 20%

LUMBER

TOP CHORD 2x4 SP No.2
BOT CHORD 2x4 SP No.1 *Except* 8-7:2x4 SP No.2
WEBS 2x4 SP No.2 *Except* 9-3:2x4 SP No.3

5) This truss is designed in accordance with the 2015 International Residential Code sections R502.11.1 and R802.10.2 and referenced standard ANSI/TPI 1.

LOAD CASE(S) Standard

BRACING

TOP CHORD Structural wood sheathing directly applied or 3-9-5 oc purlins, except end verticals.
BOT CHORD Rigid ceiling directly applied or 10-0-0 oc bracing.
WEBS 1 Row at midpt 6-7, 5-7

REACTIONS

(size) 2=0-5-8, 7=0-5-8
Max Horiz 2=329 (LC 11)
Max Uplift 2=-39 (LC 12), 7=-105 (LC 12)
Max Grav 2=896 (LC 1), 7=834 (LC 19)

FORCES

(lb) - Maximum Compression/Maximum Tension
TOP CHORD 1-2=0/27, 2-3=-1319/73, 3-5=-1050/74, 5-6=-202/127, 6-7=-171/113
BOT CHORD 2-9=-185/1135, 7-9=-152/585
WEBS 5-7=-813/163, 5-9=0/675, 3-9=-424/162

NOTES

- 1) Wind: ASCE 7-10; Vult=115mph (3-second gust) Vasd=91mph; TCDL=6.0psf; BCDL=6.0psf; h=30ft; Cat. II; Exp B; Enclosed; MWFRS (envelope) exterior zone and C-C Exterior (2) -1-0-0 to 3-6-6, Interior (1) 3-6-6 to 20-10-4 zone; cantilever left and right exposed; end vertical left and right exposed; C-C for members and forces & MWFRS for reactions shown; Lumber DOL=1.60 plate grip DOL=1.60
- 2) This truss has been designed for a 10.0 psf bottom chord live load nonconcurrent with any other live loads.
- 3) * This truss has been designed for a live load of 20.0psf on the bottom chord in all areas where a rectangle 3-06-00 tall by 1-00-00 wide will fit between the bottom chord and any other members, with BCDL = 10.0psf.
- 4) Provide mechanical connection (by others) of truss to bearing plate capable of withstanding 105 lb uplift at joint 7 and 39 lb uplift at joint 2.

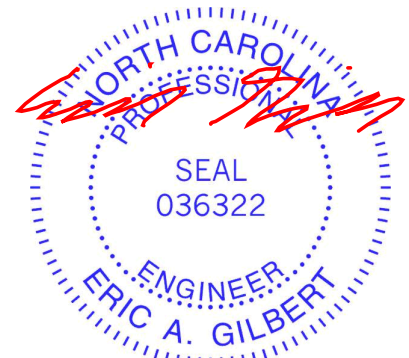

January 17, 2023

WARNING - Verify design parameters and READ NOTES ON THIS AND INCLUDED MITEK REFERENCE PAGE MII-7473 rev. 5/19/2020 BEFORE USE.

Design valid for use only with MiTek® connectors. This design is based only upon parameters shown, and is for an individual building component, not a truss system. Before use, the building designer must verify the applicability of design parameters and properly incorporate this design into the overall building design. Bracing indicated is to prevent buckling of individual truss web and/or chord members only. Additional temporary and permanent bracing is always required for stability and to prevent collapse with possible personal injury and property damage. For general guidance regarding the fabrication, storage, delivery, erection and bracing of trusses and truss systems, see **ANSI/TPI1 Quality Criteria, DSB-89 and BCSI Building Component Safety Information** available from Truss Plate Institute, 2670 Crain Highway, Suite 203 Waldorf, MD 20601



818 Soundside Road
Edenton, NC 27932

Job 36029A	Truss PB2	Truss Type Piggyback	Qty 5	Ply 1	57 SERENITY Job Reference (optional)	156131982
---------------	--------------	-------------------------	----------	----------	---	-----------

84 Components (Dunn), Dunn, NC - 28334,

Run: 8.63 S Nov 19 2022 Print: 8.630 S Nov 19 2022 MiTek Industries, Inc. Fri Jan 13 10:17:11
ID:D3KSORn6Jb4boeBSiwQ2A5y6MjS-RfC?PsB70Hq3NSgPqnL8w3ulTXbGKwRCDoi7J4zJC?f

Page: 1

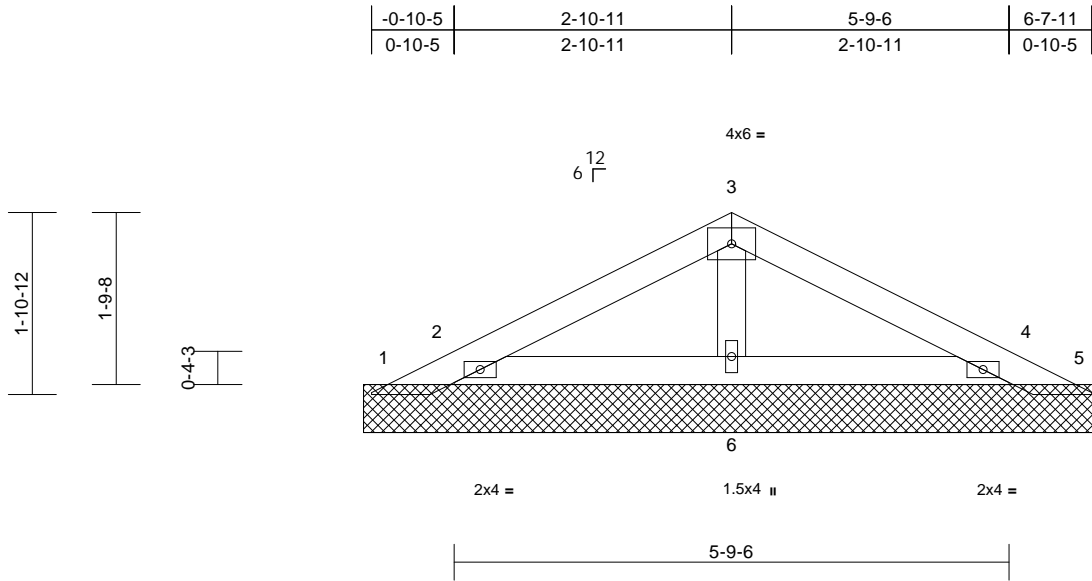

Scale = 1:24

Loading	(psf)	Spacing	2-0-0	CSI	DEFL	in	(loc)	l/defl	L/d	PLATES	GRIP	
TCLL (roof)	20.0	Plate Grip DOL	1.15	TC	0.13	Vert(LL)	n/a	-	n/a	999	MT20	244/190
TCDL	10.0	Lumber DOL	1.15	BC	0.07	Vert(TL)	n/a	-	n/a	999		
BCLL	0.0*	Rep Stress Incr	YES	WB	0.02	Horiz(TL)	0.00	4	n/a	n/a		
BCDL	10.0	Code	IRC2015/TPI2014	Matrix-MP							Weight: 23 lb	FT = 20%

LUMBER

TOP CHORD 2x4 SP No.2
BOT CHORD 2x4 SP No.2
OTHERS 2x4 SP No.3

BRACING

TOP CHORD Structural wood sheathing directly applied or 6-0-0 oc purlins.
BOT CHORD Rigid ceiling directly applied or 10-0-0 oc bracing.

REACTIONS

(size) 1=7-8-0, 2=7-8-0, 4=7-8-0,
5=7-8-0, 6=7-8-0, 7=7-8-0,
10=7-8-0
Max Horiz 1=-23 (LC 13)
Max Uplift 1=-81 (LC 23), 2=-39 (LC 12),
4=-42 (LC 13), 5=-77 (LC 24),
7=-39 (LC 12), 10=-42 (LC 13)
Max Grav 1=28 (LC 12), 2=274 (LC 23),
4=259 (LC 24), 5=20 (LC 13),
6=188 (LC 1), 7=274 (LC 23),
10=259 (LC 24)

FORCES

(lb) - Maximum Compression/Maximum Tension
TOP CHORD 1-2=-32/63, 2-3=-63/44, 3-4=-64/44,
4-5=-16/55
BOT CHORD 2-6=-23/30, 4-6=-23/30
WEBS 3-6=-99/29

NOTES

- 1) Unbalanced roof live loads have been considered for this design.
- 2) Wind: ASCE 7-10; Vult=115mph (3-second gust) Vasd=91mph; TC DL=6.0psf; BC DL=6.0psf; h=30ft; Cat. II; Exp B; Enclosed; MWFRS (envelope) exterior zone and C-C Exterior (2) zone; cantilever left and right exposed; end vertical left and right exposed; C-C for members and forces & MWFRS for reactions shown; Lumber DOL=1.60 plate grip DOL=1.60

- 3) Truss designed for wind loads in the plane of the truss only. For studs exposed to wind (normal to the face), see Standard Industry Gable End Details as applicable, or consult qualified building designer as per ANSI/TPI 1.
- 4) Gable requires continuous bottom chord bearing.
- 5) Gable studs spaced at 2-0-0 oc.
- 6) This truss has been designed for a 10.0 psf bottom chord live load nonconcurrent with any other live loads.
- 7) * This truss has been designed for a live load of 20.0psf on the bottom chord in all areas where a rectangle 3-06-00 tall by 1-00-00 wide will fit between the bottom chord and any other members.
- 8) Provide mechanical connection (by others) of truss to bearing plate capable of withstanding 39 lb uplift at joint 2, 42 lb uplift at joint 4, 81 lb uplift at joint 1, 77 lb uplift at joint 5, 39 lb uplift at joint 2 and 42 lb uplift at joint 4.
- 9) This truss is designed in accordance with the 2015 International Residential Code sections R502.11.1 and R802.10.2 and referenced standard ANSI/TPI 1.
- 10) See Standard Industry Piggyback Truss Connection Detail for Connection to base truss as applicable, or consult qualified building designer.

LOAD CASE(S) Standard



January 17, 2023

WARNING - Verify design parameters and READ NOTES ON THIS AND INCLUDED MITEK REFERENCE PAGE MII-7473 rev. 5/19/2020 BEFORE USE.

Design valid for use only with MiTek® connectors. This design is based only upon parameters shown, and is for an individual building component, not a truss system. Before use, the building designer must verify the applicability of design parameters and properly incorporate this design into the overall building design. Bracing indicated is to prevent buckling of individual truss web and/or chord members only. Additional temporary and permanent bracing is always required for stability and to prevent collapse with possible personal injury and property damage. For general guidance regarding the fabrication, storage, delivery, erection and bracing of trusses and truss systems, see ANSI/TPI1 Quality Criteria, DSB-89 and BCSI Building Component Safety Information available from Truss Plate Institute, 2670 Crain Highway, Suite 203 Waldorf, MD 20601

ANSI/TPI1 Quality Criteria, DSB-89 and BCSI Building Component



818 Soundside Road
Edenton, NC 27932

Job 36029A	Truss V1	Truss Type Valley	Qty 1	Ply 1	57 SERENITY Job Reference (optional)	156131983
---------------	-------------	----------------------	----------	----------	---	-----------

84 Components (Dunn), Dunn, NC - 28334,

Run: 8.63 S Nov 19 2022 Print: 8.630 S Nov 19 2022 MiTek Industries, Inc. Fri Jan 13 10:17:12
ID:5WvwdwNWKiThWvn92jz6XHy6Lm0-RfC?PsB70Hq3NSgPqnL8w3uITXbGKWrCDoi7J4zJC?f

Page: 1

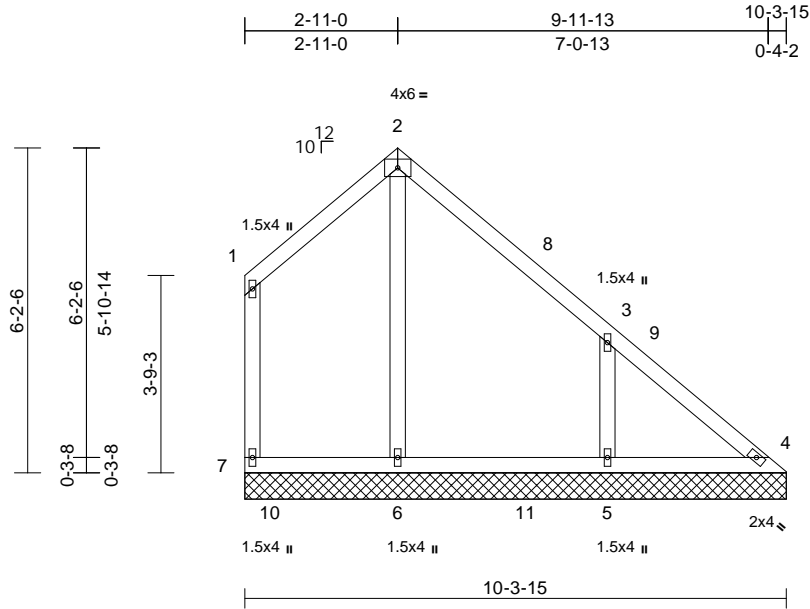

Scale = 1:43.9

Loading	(psf)	Spacing	2-0-0	CSI	DEFL	in	(loc)	l/defl	L/d	PLATES	GRIP	
TCLL (roof)	20.0	Plate Grip DOL	1.15	TC	0.22	Vert(LL)	n/a	-	n/a	999	MT20	244/190
TCDL	10.0	Lumber DOL	1.15	BC	0.14	Vert(TL)	n/a	-	n/a	999		
BCLL	0.0*	Rep Stress Incr	YES	WB	0.13	Horiz(TL)	0.00	4	n/a	n/a		
BCDL	10.0	Code	IRC2015/TPI2014	Matrix-P							Weight: 52 lb	FT = 20%

LUMBER	
TOP CHORD	2x4 SP No.2
BOT CHORD	2x4 SP No.2
WEBS	2x4 SP No.3
OTHERS	2x4 SP No.3

BRACING	
TOP CHORD	Structural wood sheathing directly applied or 6-0-0 oc purlins, except end verticals.
BOT CHORD	Rigid ceiling directly applied or 10-0-0 oc bracing.

REACTIONS (size)	
	4=10-3-15, 5=10-3-15, 6=10-3-15, 7=10-3-15
Max Horiz	7=-150 (LC 8)
Max Uplift	4=-39 (LC 9), 5=-127 (LC 13), 6=-5 (LC 8), 7=-36 (LC 9)
Max Grav	4=127 (LC 19), 5=384 (LC 20), 6=382 (LC 20), 7=151 (LC 19)

FORCES (lb) - Maximum Compression/Maximum Tension	
TOP CHORD	1-7=-125/98, 1-2=-112/121, 2-3=-149/122, 3-4=-153/161
BOT CHORD	6-7=-123/130, 5-6=-123/130, 4-5=-123/130
WEBS	2-6=-197/54, 3-5=-285/175

- NOTES**
- Unbalanced roof live loads have been considered for this design.
 - Wind: ASCE 7-10; Vult=115mph (3-second gust) Vasd=91mph; TCDL=6.0psf; BCDL=6.0psf; h=30ft; Cat. II; Exp B; Enclosed; MWFRS (envelope) exterior zone and C-C Exterior (2) 0-1-12 to 7-5-6, Interior (1) 7-5-6 to 9-11-6 zone; cantilever left and right exposed; end vertical left and right exposed; C-C for members and forces & MWFRS for reactions shown; Lumber DOL=1.60 plate grip DOL=1.60
 - Truss designed for wind loads in the plane of the truss only. For studs exposed to wind (normal to the face), see Standard Industry Gable End Details as applicable, or consult qualified building designer as per ANSI/TPI 1.
 - Gable requires continuous bottom chord bearing.

- Gable studs spaced at 4-0-0 oc.
 - This truss has been designed for a 10.0 psf bottom chord live load nonconcurrent with any other live loads.
 - * This truss has been designed for a live load of 20.0psf on the bottom chord in all areas where a rectangle 3-06-00 tall by 1-00-00 wide will fit between the bottom chord and any other members, with BCDL = 10.0psf.
 - Provide mechanical connection (by others) of truss to bearing plate capable of withstanding 36 lb uplift at joint 7, 39 lb uplift at joint 4, 5 lb uplift at joint 6 and 127 lb uplift at joint 5.
 - This truss is designed in accordance with the 2015 International Residential Code sections R502.11.1 and R802.10.2 and referenced standard ANSI/TPI 1.
- LOAD CASE(S)** Standard



January 17, 2023

WARNING - Verify design parameters and READ NOTES ON THIS AND INCLUDED MITEK REFERENCE PAGE MII-7473 rev. 5/19/2020 BEFORE USE.

Design valid for use only with MiTek® connectors. This design is based only upon parameters shown, and is for an individual building component, not a truss system. Before use, the building designer must verify the applicability of design parameters and properly incorporate this design into the overall building design. Bracing indicated is to prevent buckling of individual truss web and/or chord members only. Additional temporary and permanent bracing is always required for stability and to prevent collapse with possible personal injury and property damage. For general guidance regarding the fabrication, storage, delivery, erection and bracing of trusses and truss systems, see

Safety Information available from Truss Plate Institute, 2670 Crain Highway, Suite 203 Waldorf, MD 20601

ANSI/TPI1 Quality Criteria, DSB-89 and BCSI Building Component



818 Soundside Road
Edenton, NC 27932

Job 36029A	Truss V2	Truss Type Valley	Qty 1	Ply 1	57 SERENITY Job Reference (optional)	156131984
---------------	-------------	----------------------	----------	----------	---	-----------

84 Components (Dunn), Dunn, NC - 28334,

Run: 8.63 S Nov 19 2022 Print: 8.630 S Nov 19 2022 MiTek Industries, Inc. Fri Jan 13 10:17:12
ID:ZiUhrGO840bY82MLcQL3Uy6Lm?-RfC?PsB70Hq3NSgPqnL8w3uITXbGKwRcDoi7J4zJC7f

Page: 1

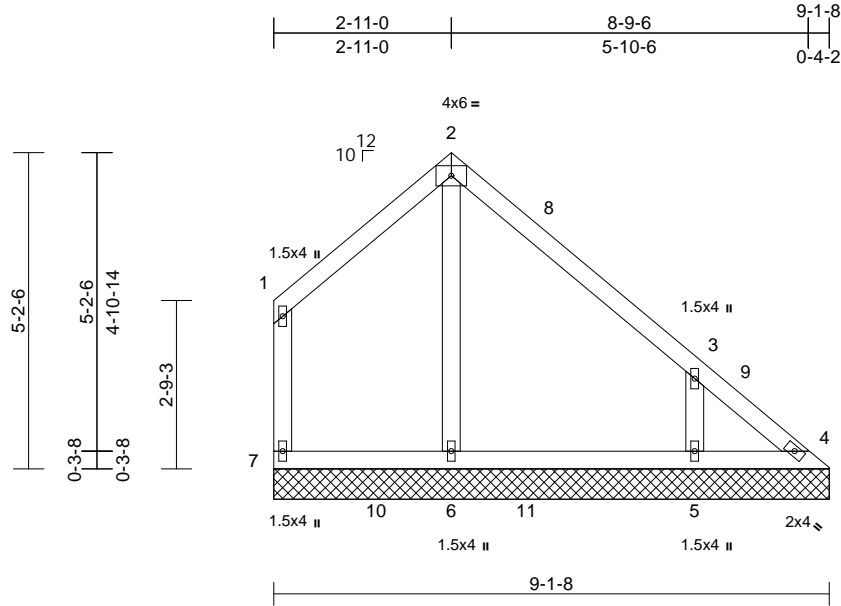

Scale = 1:37.9

Loading	(psf)	Spacing	2-0-0	CSI	DEFL	in	(loc)	l/defl	L/d	PLATES	GRIP	
TCLL (roof)	20.0	Plate Grip DOL	1.15	TC	0.21	Vert(LL)	n/a	-	n/a	999	MT20	244/190
TCDL	10.0	Lumber DOL	1.15	BC	0.10	Vert(TL)	n/a	-	n/a	999		
BCLL	0.0*	Rep Stress Incr	YES	WB	0.09	Horiz(TL)	0.00	4	n/a	n/a		
BCDL	10.0	Code	IRC2015/TPI2014	Matrix-P							Weight: 43 lb	FT = 20%

LUMBER

- TOP CHORD 2x4 SP No.2
- BOT CHORD 2x4 SP No.2
- WEBS 2x4 SP No.3
- OTHERS 2x4 SP No.3

BRACING

- TOP CHORD Structural wood sheathing directly applied or 6-0-0 oc purlins, except end verticals.
- BOT CHORD Rigid ceiling directly applied or 10-0-0 oc bracing.

REACTIONS

- (size) 4=9-1-8, 5=9-1-8, 6=9-1-8, 7=9-1-8
- Max Horiz 7=-120 (LC 8)
- Max Uplift 4=-58 (LC 11), 5=-119 (LC 13), 7=-32 (LC 12)
- Max Grav 4=89 (LC 8), 5=335 (LC 20), 6=340 (LC 20), 7=127 (LC 19)

FORCES

(lb) - Maximum Compression/Maximum Tension

- TOP CHORD 1-7=-115/88, 1-2=-96/104, 2-3=-138/102, 3-4=-134/136
- BOT CHORD 6-7=-90/104, 5-6=-90/104, 4-5=-90/104
- WEBS 2-6=-194/42, 3-5=-262/164

NOTES

- Unbalanced roof live loads have been considered for this design.
- Wind: ASCE 7-10; Vult=115mph (3-second gust) Vasd=91mph; TCDL=6.0psf; BCDL=6.0psf; h=30ft; Cat. II; Exp B; Enclosed; MWFRS (envelope) exterior zone and C-C Exterior (2) 0-1-12 to 7-5-6, Interior (1) 7-5-6 to 8-9-0 zone; cantilever left and right exposed; end vertical left and right exposed; C-C for members and forces & MWFRS for reactions shown; Lumber DOL=1.60 plate grip DOL=1.60
- Truss designed for wind loads in the plane of the truss only. For studs exposed to wind (normal to the face), see Standard Industry Gable End Details as applicable, or consult qualified building designer as per ANSI/TPI 1.
- Gable requires continuous bottom chord bearing.
- Gable studs spaced at 4-0-0 oc.

- This truss has been designed for a 10.0 psf bottom chord live load nonconcurrent with any other live loads.
- * This truss has been designed for a live load of 20.0psf on the bottom chord in all areas where a rectangle 3-06-00 tall by 1-00-00 wide will fit between the bottom chord and any other members, with BCDL = 10.0psf.
- Provide mechanical connection (by others) of truss to bearing plate capable of withstanding 32 lb uplift at joint 7, 58 lb uplift at joint 4 and 119 lb uplift at joint 5.
- This truss is designed in accordance with the 2015 International Residential Code sections R502.11.1 and R802.10.2 and referenced standard ANSI/TPI 1.

LOAD CASE(S) Standard

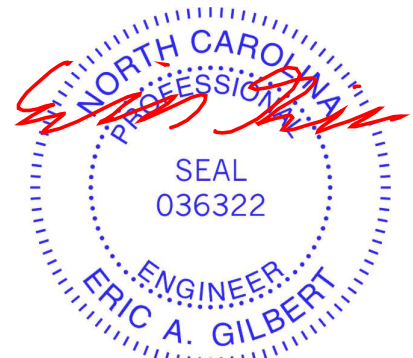

January 17, 2023

WARNING - Verify design parameters and READ NOTES ON THIS AND INCLUDED MITEK REFERENCE PAGE MII-7473 rev. 5/19/2020 BEFORE USE.

Design valid for use only with MiTek® connectors. This design is based only upon parameters shown, and is for an individual building component, not a truss system. Before use, the building designer must verify the applicability of design parameters and properly incorporate this design into the overall building design. Bracing indicated is to prevent buckling of individual truss web and/or chord members only. Additional temporary and permanent bracing is always required for stability and to prevent collapse with possible personal injury and property damage. For general guidance regarding the fabrication, storage, delivery, erection and bracing of trusses and truss systems, see

ANSI/TPI1 Quality Criteria, DSB-89 and BCSI Building Component

Safety Information available from Truss Plate Institute, 2670 Crain Highway, Suite 203 Waldorf, MD 20601



818 Soundside Road
Edenton, NC 27932

Job 36029A	Truss V3	Truss Type Valley	Qty 1	Ply 1	57 SERENITY Job Reference (optional)	156131985
---------------	-------------	----------------------	----------	----------	---	-----------

84 Components (Dunn), Dunn, NC - 28334,

Run: 8.63 S Nov 19 2022 Print: 8.630 S Nov 19 2022 MiTek Industries, Inc. Fri Jan 13 10:17:12
ID:ZiUhrGO840bY82MLcQUL3Uy6Lm?-RfC?PsB70Hq3NSgPqnL8w3uITXbGKWrCDoi7J4zJC7f

Page: 1

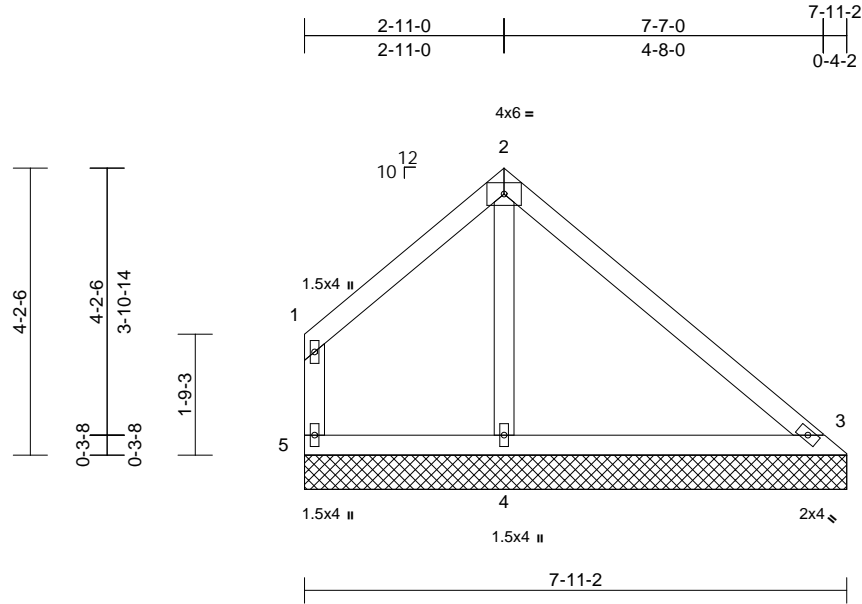

Scale = 1:33.7

Loading	(psf)	Spacing	2-0-0	CSI	DEFL	in	(loc)	l/defl	L/d	PLATES	GRIP	
TCLL (roof)	20.0	Plate Grip DOL	1.15	TC	0.43	Vert(LL)	n/a	-	n/a	999	MT20	244/190
TCDL	10.0	Lumber DOL	1.15	BC	0.17	Vert(TL)	n/a	-	n/a	999		
BCLL	0.0*	Rep Stress Incr	YES	WB	0.07	Horiz(TL)	0.00	3	n/a	n/a		
BCDL	10.0	Code	IRC2015/TPI2014	Matrix-P							Weight: 34 lb	FT = 20%

LUMBER

TOP CHORD 2x4 SP No.2
BOT CHORD 2x4 SP No.2
WEBS 2x4 SP No.3
OTHERS 2x4 SP No.3

BRACING

TOP CHORD Structural wood sheathing directly applied or 7-11-7 oc purlins, except end verticals.
BOT CHORD Rigid ceiling directly applied or 10-0-0 oc bracing.

REACTIONS

(size) 3=7-11-2, 4=7-11-2, 5=7-11-2
Max Horiz 5=-90 (LC 10)
Max Uplift 3=-14 (LC 13), 5=-40 (LC 12)
Max Grav 3=177 (LC 1), 4=331 (LC 20), 5=112 (LC 19)

FORCES

(lb) - Maximum Compression/Maximum Tension

TOP CHORD 1-5=-105/77, 1-2=-80/86, 2-3=-116/104
BOT CHORD 4-5=-67/81, 3-4=-67/81
WEBS 2-4=-234/57

NOTES

- Unbalanced roof live loads have been considered for this design.
- Wind: ASCE 7-10; Vult=115mph (3-second gust) Vasd=91mph; TC DL=6.0psf; BCDL=6.0psf; h=30ft; Cat. II; Exp B; Enclosed; MWFRS (envelope) exterior zone and C-C Exterior (2) zone; cantilever left and right exposed; end vertical left and right exposed; C-C for members and forces & MWFRS for reactions shown; Lumber DOL=1.60 plate grip DOL=1.60
- Truss designed for wind loads in the plane of the truss only. For studs exposed to wind (normal to the face), see Standard Industry Gable End Details as applicable, or consult qualified building designer as per ANSI/TPI 1.
- Gable requires continuous bottom chord bearing.
- Gable studs spaced at 2-0-0 oc.
- This truss has been designed for a 10.0 psf bottom chord live load nonconcurrent with any other live loads.

- * This truss has been designed for a live load of 20.0psf on the bottom chord in all areas where a rectangle 3-06-00 tall by 1-00-00 wide will fit between the bottom chord and any other members.
- Provide mechanical connection (by others) of truss to bearing plate capable of withstanding 40 lb uplift at joint 5 and 14 lb uplift at joint 3.
- This truss is designed in accordance with the 2015 International Residential Code sections R502.11.1 and R802.10.2 and referenced standard ANSI/TPI 1.

LOAD CASE(S) Standard



January 17, 2023

WARNING - Verify design parameters and READ NOTES ON THIS AND INCLUDED MITEK REFERENCE PAGE MII-7473 rev. 5/19/2020 BEFORE USE.

Design valid for use only with MiTek® connectors. This design is based only upon parameters shown, and is for an individual building component, not a truss system. Before use, the building designer must verify the applicability of design parameters and properly incorporate this design into the overall building design. Bracing indicated is to prevent buckling of individual truss web and/or chord members only. Additional temporary and permanent bracing is always required for stability and to prevent collapse with possible personal injury and property damage. For general guidance regarding the fabrication, storage, delivery, erection and bracing of trusses and truss systems, see **ANSI/TPI1 Quality Criteria, DSB-89 and BCSI Building Component Safety Information** available from Truss Plate Institute, 2670 Crain Highway, Suite 203 Waldorf, MD 20601



818 Soundside Road
Edenton, NC 27932

Job 36029A	Truss V4	Truss Type Valley	Qty 1	Ply 1	57 SERENITY Job Reference (optional)	I56131986
---------------	-------------	----------------------	----------	----------	---	-----------

84 Components (Dunn), Dunn, NC - 28334,

Run: 8.63 S Nov 19 2022 Print: 8.630 S Nov 19 2022 MiTek Industries, Inc. Fri Jan 13 10:17:13
ID:ZiUHrGO840bY82MLcQUL3Uy6Lm?-RfC?PsB70Hq3NSgPqnL8w3uITXbGKWrCDoi7J4zJC?f

Page: 1

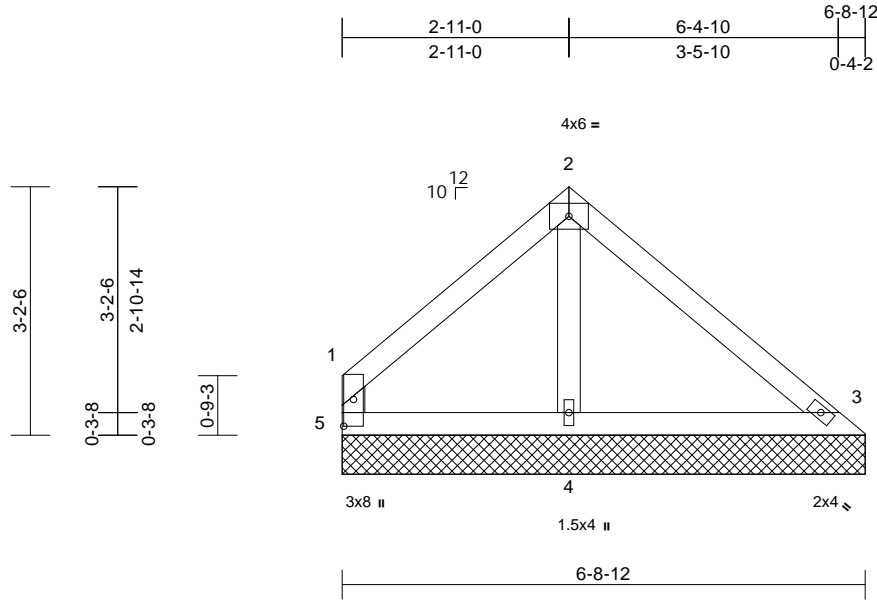

Scale = 1:29.6

Plate Offsets (X, Y): [5:0-4-2,0-1-8]

Loading	(psf)	Spacing	2-0-0	CSI	DEFL	in	(loc)	l/defl	L/d	PLATES	GRIP	
TCLL (roof)	20.0	Plate Grip DOL	1.15	TC	0.22	Vert(LL)	n/a	-	n/a	999	MT20	244/190
TCDL	10.0	Lumber DOL	1.15	BC	0.10	Vert(TL)	n/a	-	n/a	999		
BCLL	0.0*	Rep Stress Incr	YES	WB	0.04	Horiz(TL)	0.00	3	n/a	n/a		
BCDL	10.0	Code	IRC2015/TPI2014	Matrix-P							Weight: 27 lb	FT = 20%

LUMBER

TOP CHORD 2x4 SP No.2
BOT CHORD 2x4 SP No.2
WEBS 2x4 SP No.3
OTHERS 2x4 SP No.3

BRACING

TOP CHORD Structural wood sheathing directly applied or 6-9-0 oc purlins, except end verticals.
BOT CHORD Rigid ceiling directly applied or 10-0-0 oc bracing.

REACTIONS

(size) 3=6-8-12, 4=6-8-12, 5=6-8-12
Max Horiz 5=-61 (LC 8)
Max Uplift 3=-28 (LC 12), 5=-41 (LC 12)
Max Grav 3=130 (LC 1), 4=269 (LC 20), 5=111 (LC 19)

FORCES

(lb) - Maximum Compression/Maximum Tension

TOP CHORD 1-5=-94/67, 1-2=-63/68, 2-3=-86/80
BOT CHORD 4-5=-53/58, 3-4=-53/58
WEBS 2-4=-191/22

NOTES

- Unbalanced roof live loads have been considered for this design.
- Wind: ASCE 7-10; Vult=115mph (3-second gust) Vasd=91mph; TC DL=6.0psf; BC DL=6.0psf; h=30ft; Cat. II; Exp B; Enclosed; MWFRS (envelope) exterior zone and C-C Exterior (2) zone; cantilever left and right exposed; end vertical left and right exposed; C-C for members and forces & MWFRS for reactions shown; Lumber DOL=1.60 plate grip DOL=1.60
- Truss designed for wind loads in the plane of the truss only. For studs exposed to wind (normal to the face), see Standard Industry Gable End Details as applicable, or consult qualified building designer as per ANSI/TPI 1.
- Gable requires continuous bottom chord bearing.
- Gable studs spaced at 2-0-0 oc.
- This truss has been designed for a 10.0 psf bottom chord live load nonconcurrent with any other live loads.

- * This truss has been designed for a live load of 20.0psf on the bottom chord in all areas where a rectangle 3-06-00 tall by 1-00-00 wide will fit between the bottom chord and any other members.
- Provide mechanical connection (by others) of truss to bearing plate capable of withstanding 41 lb uplift at joint 5 and 28 lb uplift at joint 3.
- This truss is designed in accordance with the 2015 International Residential Code sections R502.11.1 and R802.10.2 and referenced standard ANSI/TPI 1.

LOAD CASE(S) Standard

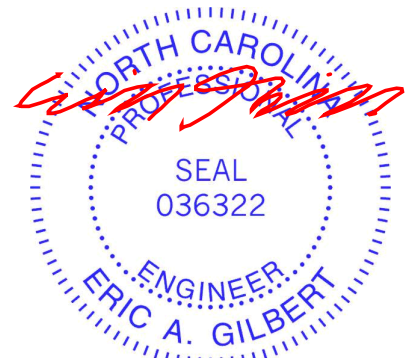

January 17, 2023

WARNING - Verify design parameters and READ NOTES ON THIS AND INCLUDED MITEK REFERENCE PAGE MII-7473 rev. 5/19/2020 BEFORE USE.

Design valid for use only with MiTek® connectors. This design is based only upon parameters shown, and is for an individual building component, not a truss system. Before use, the building designer must verify the applicability of design parameters and properly incorporate this design into the overall building design. Bracing indicated is to prevent buckling of individual truss web and/or chord members only. Additional temporary and permanent bracing is always required for stability and to prevent collapse with possible personal injury and property damage. For general guidance regarding the fabrication, storage, delivery, erection and bracing of trusses and truss systems, see

ANSI/TPI1 Quality Criteria, DSB-89 and BCSI Building Component

Safety Information available from Truss Plate Institute, 2670 Crain Highway, Suite 203 Waldorf, MD 20601



818 Soundside Road
Edenton, NC 27932

Job 36029A	Truss V5	Truss Type Valley	Qty 1	Ply 1	57 SERENITY Job Reference (optional)	156131987
---------------	-------------	----------------------	----------	----------	---	-----------

84 Components (Dunn), Dunn, NC - 28334,

Run: 8.63 S Nov 19 2022 Print: 8.630 S Nov 19 2022 MiTek Industries, Inc. Fri Jan 13 10:17:13
ID:ZiUHrGO840bY82MLcQUL3Uy6Lm?-RfC?PsB70Hq3NSgPqnL8w3uITXbGKWrCDoi7J4zJC?f

Page: 1

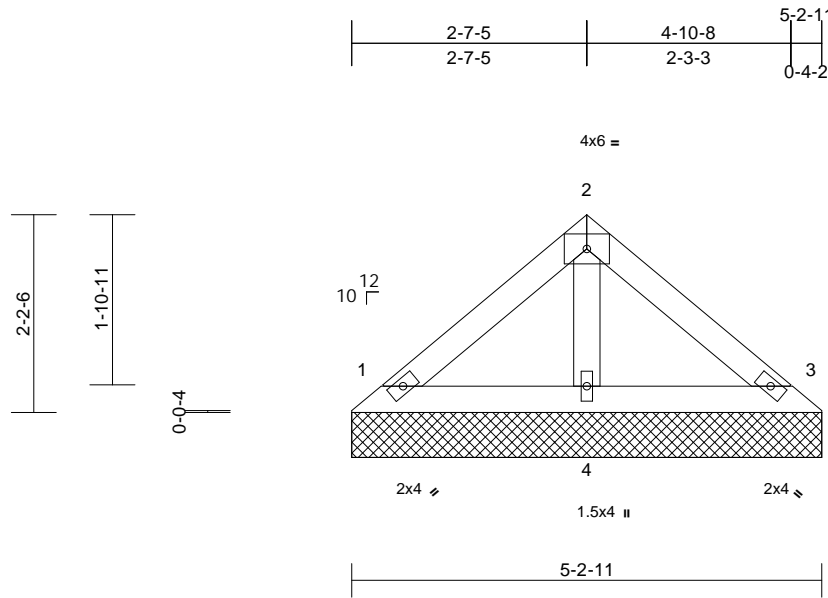

Scale = 1:25.6

Loading	(psf)	Spacing	2-0-0	CSI	DEFL	in	(loc)	l/defl	L/d	PLATES	GRIP	
TCLL (roof)	20.0	Plate Grip DOL	1.15	TC	0.15	Vert(LL)	n/a	-	n/a	999	MT20	244/190
TCDL	10.0	Lumber DOL	1.15	BC	0.09	Vert(TL)	n/a	-	n/a	999		
BCLL	0.0*	Rep Stress Incr	YES	WB	0.02	Horiz(TL)	0.00	3	n/a	n/a		
BCDL	10.0	Code	IRC2015/TPI2014	Matrix-P							Weight: 19 lb	FT = 20%

LUMBER

TOP CHORD 2x4 SP No.3
BOT CHORD 2x4 SP No.3
OTHERS 2x4 SP No.3

BRACING

TOP CHORD Structural wood sheathing directly applied or 5-3-4 oc purlins.
BOT CHORD Rigid ceiling directly applied or 10-0-0 oc bracing.

REACTIONS

(size) 1=5-2-11, 3=5-2-11, 4=5-2-11
Max Horiz 1=36 (LC 9)
Max Uplift 1=-11 (LC 13), 3=-15 (LC 13)
Max Grav 1=102 (LC 1), 3=102 (LC 1), 4=154 (LC 1)

FORCES

(lb) - Maximum Compression/Maximum Tension

TOP CHORD 1-2=-65/30, 2-3=-62/26
BOT CHORD 1-4=-7/29, 3-4=-7/29
WEBS 2-4=-98/23

NOTES

- 1) Unbalanced roof live loads have been considered for this design.
- 2) Wind: ASCE 7-10; Vult=115mph (3-second gust) Vasd=91mph; TCCL=6.0psf; BCDL=6.0psf; h=30ft; Cat. II; Exp B; Enclosed; MWFRS (envelope) exterior zone and C-C Exterior (2) zone; cantilever left and right exposed; end vertical left and right exposed; C-C for members and forces & MWFRS for reactions shown; Lumber DOL=1.60 plate grip DOL=1.60
- 3) Truss designed for wind loads in the plane of the truss only. For studs exposed to wind (normal to the face), see Standard Industry Gable End Details as applicable, or consult qualified building designer as per ANSI/TPI 1.
- 4) Gable requires continuous bottom chord bearing.
- 5) Gable studs spaced at 2-0-0 oc.
- 6) This truss has been designed for a 10.0 psf bottom chord live load nonconcurrent with any other live loads.

- 7) * This truss has been designed for a live load of 20.0psf on the bottom chord in all areas where a rectangle 3-06-00 tall by 1-00-00 wide will fit between the bottom chord and any other members.
- 8) Provide mechanical connection (by others) of truss to bearing plate capable of withstanding 11 lb uplift at joint 1 and 15 lb uplift at joint 3.
- 9) This truss is designed in accordance with the 2015 International Residential Code sections R502.11.1 and R802.10.2 and referenced standard ANSI/TPI 1.

LOAD CASE(S) Standard

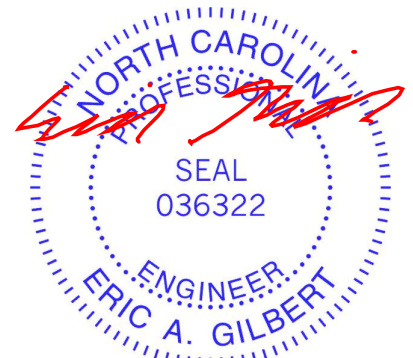

January 17, 2023

WARNING - Verify design parameters and READ NOTES ON THIS AND INCLUDED MITEK REFERENCE PAGE MII-7473 rev. 5/19/2020 BEFORE USE.

Design valid for use only with MiTek® connectors. This design is based only upon parameters shown, and is for an individual building component, not a truss system. Before use, the building designer must verify the applicability of design parameters and properly incorporate this design into the overall building design. Bracing indicated is to prevent buckling of individual truss web and/or chord members only. Additional temporary and permanent bracing is always required for stability and to prevent collapse with possible personal injury and property damage. For general guidance regarding the fabrication, storage, delivery, erection and bracing of trusses and truss systems, see **ANSI/TPI1 Quality Criteria, DSB-89 and BCSI Building Component Safety Information** available from Truss Plate Institute, 2670 Crain Highway, Suite 203 Waldorf, MD 20601



818 Soundside Road
Edenton, NC 27932

Job 36029A	Truss V8	Truss Type Valley	Qty 1	Ply 1	57 SERENITY Job Reference (optional)	156131988
---------------	-------------	----------------------	----------	----------	---	-----------

84 Components (Dunn), Dunn, NC - 28334,

Run: 8.63 S Nov 19 2022 Print: 8.630 S Nov 19 2022 MiTek Industries, Inc. Fri Jan 13 10:17:13
ID:ZiUHrGO840bY82MLcQL3Uy6Lm?-RfC?PsB70Hq3NSgPqnL8w3uITXbGKWrCDoi7J4zJC7f

Page: 1

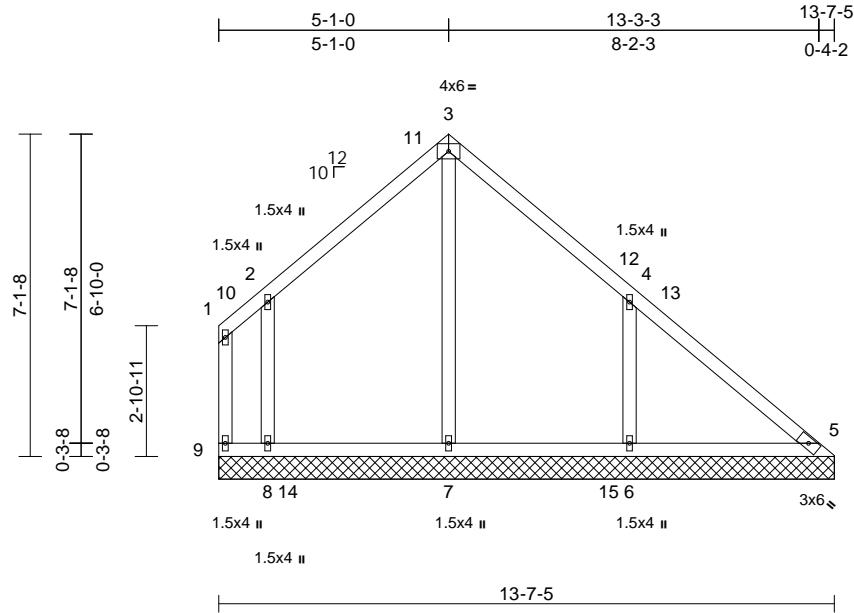

Loading	(psf)	Spacing	2-0-0	CSI	DEFL	in	(loc)	l/defl	L/d	PLATES	GRIP	
TCLL (roof)	20.0	Plate Grip DOL	1.15	TC	0.28	Vert(LL)	n/a	-	n/a	999	MT20	244/190
TCDL	10.0	Lumber DOL	1.15	BC	0.18	Vert(TL)	n/a	-	n/a	999		
BCLL	0.0*	Rep Stress Incr	YES	WB	0.17	Horiz(TL)	0.00	5	n/a	n/a		
BCDL	10.0	Code	IRC2015/TPI2014	Matrix-P							Weight: 69 lb	FT = 20%

LUMBER
TOP CHORD 2x4 SP No.2
BOT CHORD 2x4 SP No.2
WEBS 2x4 SP No.3
OTHERS 2x4 SP No.3 *Except* 7-3:2x4 SP No.2

BRACING
TOP CHORD Structural wood sheathing directly applied or 6-0-0 oc purlins, except end verticals.
BOT CHORD Rigid ceiling directly applied or 10-0-0 oc bracing.

REACTIONS (size) 5=13-7-5, 6=13-7-5, 7=13-7-5, 8=13-7-5, 9=13-7-5
Max Horiz 9=-159 (LC 8)
Max Uplift 5=-45 (LC 9), 6=-144 (LC 13), 8=-132 (LC 12), 9=-104 (LC 2)
Max Grav 5=172 (LC 19), 6=461 (LC 20), 7=423 (LC 20), 8=432 (LC 19), 9=49 (LC 12)

FORCES (lb) - Maximum Compression/Maximum Tension
TOP CHORD 1-9=-63/93, 1-2=-56/91, 2-3=-162/162, 3-4=-167/174, 4-5=-170/184
BOT CHORD 8-9=-118/142, 7-8=-118/142, 6-7=-118/142, 5-6=-118/142
WEBS 3-7=-213/51, 2-8=-289/176, 4-6=-325/199

NOTES
1) Unbalanced roof live loads have been considered for this design.
2) Wind: ASCE 7-10; Vult=115mph (3-second gust) Vasd=91mph; TCCL=6.0psf; BCDL=6.0psf; h=30ft; Cat. II; Exp B; Enclosed; MWFRS (envelope) exterior zone and C-C Exterior (2) 0-1-12 to 4-8-2, Interior (1) 4-8-2 to 5-1-0, Exterior (2) 5-1-0 to 9-7-6, Interior (1) 9-7-6 to 13-2-13 zone; cantilever left and right exposed; end vertical left and right exposed; C-C for members and forces & MWFRS for reactions shown; Lumber DOL=1.60 plate grip DOL=1.60

- Truss designed for wind loads in the plane of the truss only. For studs exposed to wind (normal to the face), see Standard Industry Gable End Details as applicable, or consult qualified building designer as per ANSI/TPI 1.
- Gable requires continuous bottom chord bearing.
- Gable studs spaced at 4-0-0 oc.
- This truss has been designed for a 10.0 psf bottom chord live load nonconcurrent with any other live loads.
- * This truss has been designed for a live load of 20.0psf on the bottom chord in all areas where a rectangle 3-06-00 tall by 1-00-00 wide will fit between the bottom chord and any other members, with BCDL = 10.0psf.
- Provide mechanical connection (by others) of truss to bearing plate capable of withstanding 104 lb uplift at joint 9, 45 lb uplift at joint 5, 132 lb uplift at joint 8 and 144 lb uplift at joint 6.
- This truss is designed in accordance with the 2015 International Residential Code sections R502.11.1 and R802.10.2 and referenced standard ANSI/TPI 1.

LOAD CASE(S) Standard



January 17, 2023

WARNING - Verify design parameters and READ NOTES ON THIS AND INCLUDED MITEK REFERENCE PAGE MII-7473 rev. 5/19/2020 BEFORE USE.

Design valid for use only with MiTek® connectors. This design is based only upon parameters shown, and is for an individual building component, not a truss system. Before use, the building designer must verify the applicability of design parameters and properly incorporate this design into the overall building design. Bracing indicated is to prevent buckling of individual truss web and/or chord members only. Additional temporary and permanent bracing is always required for stability and to prevent collapse with possible personal injury and property damage. For general guidance regarding the fabrication, storage, delivery, erection and bracing of trusses and truss systems, see **ANSI/TPI1 Quality Criteria, DSB-89 and BCSI Building Component Safety Information** available from Truss Plate Institute, 2670 Crain Highway, Suite 203 Waldorf, MD 20601



818 Soundside Road
Edenton, NC 27932

Job 36029A	Truss V9	Truss Type Valley	Qty 1	Ply 1	57 SERENITY Job Reference (optional)	156131989
---------------	-------------	----------------------	----------	----------	---	-----------

84 Components (Dunn), Dunn, NC - 28334,

Run: 8.63 S Nov 19 2022 Print: 8.630 S Nov 19 2022 MiTek Industries, Inc. Fri Jan 13 10:17:14
ID:ZiUHrGO840bY82MLcQUL3Uy6Lm?-RfC?PsB70Hq3NSgPqnL8w3uITXbGKWrCDoi7J4zJC7f

Page: 1

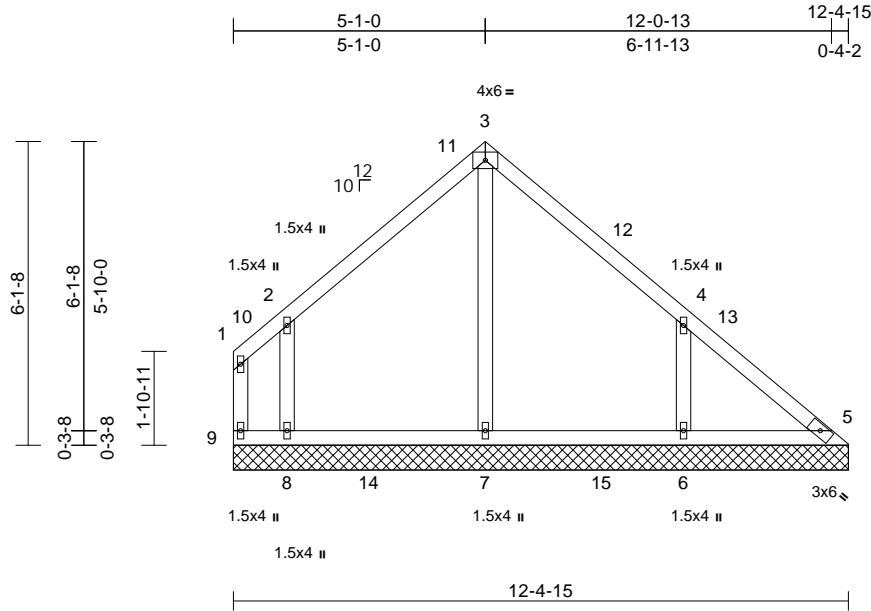

Scale = 1:46.5

Loading	(psf)	Spacing	2-0-0	CSI	DEFL	in	(loc)	l/defl	L/d	PLATES	GRIP	
TCLL (roof)	20.0	Plate Grip DOL	1.15	TC	0.22	Vert(LL)	n/a	-	n/a	999	MT20	244/190
TCDL	10.0	Lumber DOL	1.15	BC	0.15	Vert(TL)	n/a	-	n/a	999		
BCLL	0.0*	Rep Stress Incr	YES	WB	0.14	Horiz(TL)	0.00	5	n/a	n/a		
BCDL	10.0	Code	IRC2015/TPI2014	Matrix-P							Weight: 59 lb	FT = 20%

LUMBER

- TOP CHORD 2x4 SP No.2
- BOT CHORD 2x4 SP No.2
- WEBS 2x4 SP No.3
- OTHERS 2x4 SP No.3

BRACING

- TOP CHORD Structural wood sheathing directly applied or 6-0-0 oc purlins, except end verticals.
- BOT CHORD Rigid ceiling directly applied or 10-0-0 oc bracing.

- REACTIONS** (size) 5=12-4-15, 6=12-4-15, 7=12-4-15, 8=12-4-15, 9=12-4-15
- Max Horiz 9=-129 (LC 8)
 - Max Uplift 5=-53 (LC 9), 6=-127 (LC 13), 8=-135 (LC 12), 9=-94 (LC 19)
 - Max Grav 5=124 (LC 19), 6=376 (LC 20), 7=411 (LC 20), 8=390 (LC 19), 9=46 (LC 12)

FORCES

- (lb) - Maximum Compression/Maximum Tension
- TOP CHORD 1-9=-58/88, 1-2=-47/83, 2-3=-147/146, 3-4=-149/154, 4-5=-145/158
 - BOT CHORD 8-9=-104/119, 7-8=-104/119, 6-7=-104/119, 5-6=-104/119
 - WEBS 3-7=-216/34, 2-8=-291/177, 4-6=-282/173

NOTES

- Unbalanced roof live loads have been considered for this design.
- Wind: ASCE 7-10; Vult=115mph (3-second gust) Vasd=91mph; TCDL=6.0psf; BCDL=6.0psf; h=30ft; Cat. II; Exp B; Enclosed; MWFRS (envelope) exterior zone and C-C Exterior (2) 0-1-12 to 4-8-2, Interior (1) 4-8-2 to 5-1-0, Exterior (2) 5-1-0 to 9-7-6, Interior (1) 9-7-6 to 12-0-6 zone; cantilever left and right exposed; end vertical left and right exposed; C-C for members and forces & MWFRS for reactions shown; Lumber DOL=1.60 plate grip DOL=1.60

- Truss designed for wind loads in the plane of the truss only. For studs exposed to wind (normal to the face), see Standard Industry Gable End Details as applicable, or consult qualified building designer as per ANSI/TPI 1.
- Gable requires continuous bottom chord bearing.
- Gable studs spaced at 4-0-0 oc.
- This truss has been designed for a 10.0 psf bottom chord live load nonconcurrent with any other live loads.
- * This truss has been designed for a live load of 20.0psf on the bottom chord in all areas where a rectangle 3-06-00 tall by 1-00-00 wide will fit between the bottom chord and any other members, with BCDL = 10.0psf.
- Provide mechanical connection (by others) of truss to bearing plate capable of withstanding 94 lb uplift at joint 9, 53 lb uplift at joint 5, 135 lb uplift at joint 8 and 127 lb uplift at joint 6.
- This truss is designed in accordance with the 2015 International Residential Code sections R502.11.1 and R802.10.2 and referenced standard ANSI/TPI 1.

LOAD CASE(S) Standard

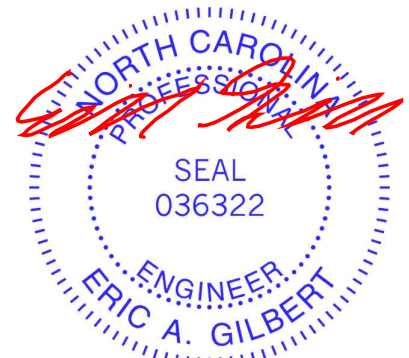

January 17, 2023

WARNING - Verify design parameters and READ NOTES ON THIS AND INCLUDED MITEK REFERENCE PAGE MII-7473 rev. 5/19/2020 BEFORE USE.

Design valid for use only with MiTek® connectors. This design is based only upon parameters shown, and is for an individual building component, not a truss system. Before use, the building designer must verify the applicability of design parameters and properly incorporate this design into the overall building design. Bracing indicated is to prevent buckling of individual truss web and/or chord members only. Additional temporary and permanent bracing is always required for stability and to prevent collapse with possible personal injury and property damage. For general guidance regarding the fabrication, storage, delivery, erection and bracing of trusses and truss systems, see **ANSI/TPI1 Quality Criteria, DSB-89 and BCSI Building Component Safety Information** available from Truss Plate Institute, 2670 Crain Highway, Suite 203 Waldorf, MD 20601



818 Soundside Road
Edenton, NC 27932

Job 36029A	Truss V10	Truss Type Valley	Qty 1	Ply 1	57 SERENITY Job Reference (optional)	156131990
---------------	--------------	----------------------	----------	----------	---	-----------

84 Components (Dunn), Dunn, NC - 28334,

Run: 8.63 S Nov 19 2022 Print: 8.630 S Nov 19 2022 MiTek Industries, Inc. Fri Jan 13 10:17:14
ID:5WvwdwNWKiThWvn9zj6XHy6Lm0-RfC?PsB70Hq3NSgPqnL8w3uITXbGKWrCDoi7J4zJC?f

Page: 1

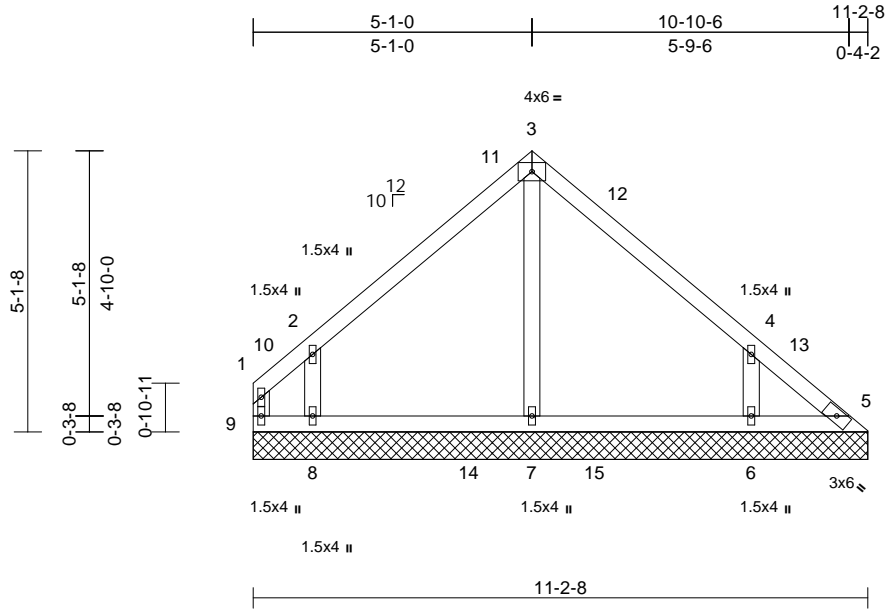

Scale = 1:42

Loading	(psf)	Spacing	2-0-0	CSI	DEFL	in	(loc)	l/defl	L/d	PLATES	GRIP	
TCLL (roof)	20.0	Plate Grip DOL	1.15	TC	0.22	Vert(LL)	n/a	-	n/a	999	MT20	244/190
TCDL	10.0	Lumber DOL	1.15	BC	0.12	Vert(TL)	n/a	-	n/a	999		
BCLL	0.0*	Rep Stress Incr	YES	WB	0.09	Horiz(TL)	0.00	5	n/a	n/a		
BCDL	10.0	Code	IRC2015/TPI2014	Matrix-P							Weight: 49 lb	FT = 20%

LUMBER

- TOP CHORD 2x4 SP No.2
- BOT CHORD 2x4 SP No.2
- WEBS 2x4 SP No.3
- OTHERS 2x4 SP No.3

BRACING

- TOP CHORD Structural wood sheathing directly applied or 6-0-0 oc purlins, except end verticals.
- BOT CHORD Rigid ceiling directly applied or 10-0-0 oc bracing.

- REACTIONS** (size)
- 5=11-2-8, 6=11-2-8, 7=11-2-8, 8=11-2-8, 9=11-2-8
 - Max Horiz 9=-100 (LC 8)
 - Max Uplift 5=-68 (LC 9), 6=-121 (LC 13), 8=-137 (LC 12), 9=-90 (LC 19)
 - Max Grav 5=83 (LC 10), 6=332 (LC 20), 7=362 (LC 20), 8=366 (LC 19), 9=43 (LC 12)

FORCES

- (lb) - Maximum Compression/Maximum Tension
- TOP CHORD 1-9=-53/82, 1-2=-38/84, 2-3=-131/129, 3-4=-138/136, 4-5=-123/143
 - BOT CHORD 8-9=-89/95, 7-8=-89/95, 6-7=-89/95, 5-6=-89/95
 - WEBS 3-7=-213/25, 2-8=-293/180, 4-6=-262/161

NOTES

- Unbalanced roof live loads have been considered for this design.
- Wind: ASCE 7-10; Vult=115mph (3-second gust) Vasd=91mph; TCCL=6.0psf; BCDL=6.0psf; h=30ft; Cat. II; Exp B; Enclosed; MWFRS (envelope) exterior zone and C-C Exterior (2) 0-1-12 to 4-8-2, Interior (1) 4-8-2 to 5-1-0, Exterior (2) 5-1-0 to 9-7-6, Interior (1) 9-7-6 to 10-10-0 zone; cantilever left and right exposed; end vertical left and right exposed; C-C for members and forces & MWFRS for reactions shown; Lumber DOL=1.60 plate grip DOL=1.60

- Truss designed for wind loads in the plane of the truss only. For studs exposed to wind (normal to the face), see Standard Industry Gable End Details as applicable, or consult qualified building designer as per ANSI/TPI 1.
- Gable requires continuous bottom chord bearing.
- Gable studs spaced at 4-0-0 oc.
- This truss has been designed for a 10.0 psf bottom chord live load nonconcurrent with any other live loads.
- * This truss has been designed for a live load of 20.0psf on the bottom chord in all areas where a rectangle 3-06-00 tall by 1-00-00 wide will fit between the bottom chord and any other members, with BCDL = 10.0psf.
- Provide mechanical connection (by others) of truss to bearing plate capable of withstanding 90 lb uplift at joint 9, 68 lb uplift at joint 5, 137 lb uplift at joint 8 and 121 lb uplift at joint 6.
- This truss is designed in accordance with the 2015 International Residential Code sections R502.11.1 and R802.10.2 and referenced standard ANSI/TPI 1.

LOAD CASE(S) Standard



January 17, 2023

WARNING - Verify design parameters and READ NOTES ON THIS AND INCLUDED MITEK REFERENCE PAGE MII-7473 rev. 5/19/2020 BEFORE USE.

Design valid for use only with MiTek® connectors. This design is based only upon parameters shown, and is for an individual building component, not a truss system. Before use, the building designer must verify the applicability of design parameters and properly incorporate this design into the overall building design. Bracing indicated is to prevent buckling of individual truss web and/or chord members only. Additional temporary and permanent bracing is always required for stability and to prevent collapse with possible personal injury and property damage. For general guidance regarding the fabrication, storage, delivery, erection and bracing of trusses and truss systems, see **ANSI/TPI1 Quality Criteria, DSB-89 and BCSI Building Component Safety Information** available from Truss Plate Institute, 2670 Crain Highway, Suite 203 Waldorf, MD 20601



818 Soundside Road
Edenton, NC 27932

Job 36029A	Truss V11	Truss Type Valley	Qty 1	Ply 1	57 SERENITY Job Reference (optional)	156131991
---------------	--------------	----------------------	----------	----------	---	-----------

84 Components (Dunn), Dunn, NC - 28334,

Run: 8.63 S Nov 19 2022 Print: 8.630 S Nov 19 2022 MiTek Industries, Inc. Fri Jan 13 10:17:15
ID:5WvvdwNWKiThWvn92jz6XHy6Lm0-RfC?PsB70Hq3NSgPqnL8w3uITXbGKWrCDoi7J4zJC?f

Page: 1

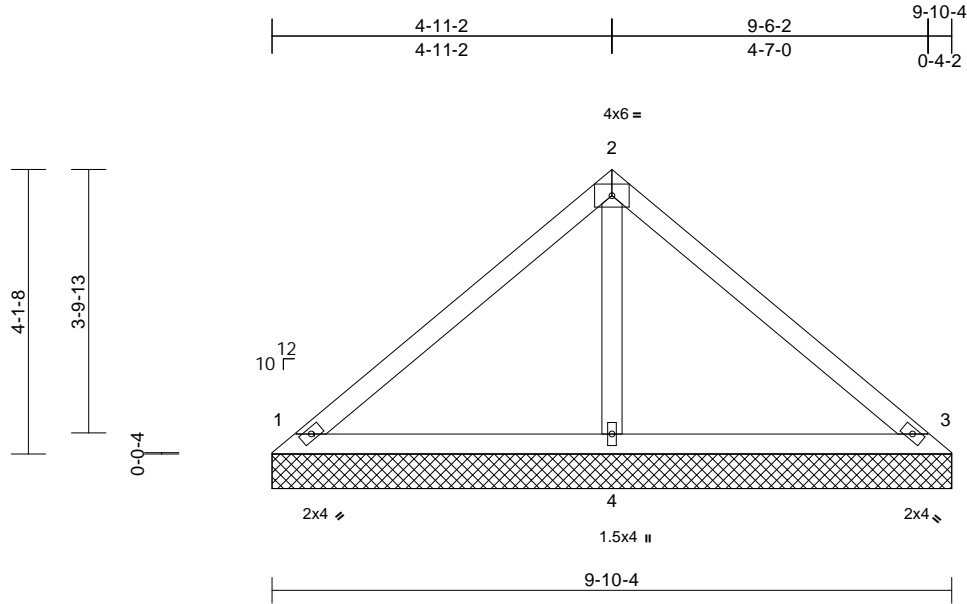

Loading	(psf)	Spacing	2-0-0	CSI	DEFL	in	(loc)	l/defl	L/d	PLATES	GRIP	
TCLL (roof)	20.0	Plate Grip DOL	1.15	TC	0.41	Vert(LL)	n/a	-	n/a	999	MT20	244/190
TCDL	10.0	Lumber DOL	1.15	BC	0.21	Vert(TL)	n/a	-	n/a	999		
BCLL	0.0*	Rep Stress Incr	YES	WB	0.06	Horiz(TL)	0.00	3	n/a	n/a		
BCDL	10.0	Code	IRC2015/TPI2014	Matrix-P							Weight: 38 lb	FT = 20%

LUMBER
TOP CHORD 2x4 SP No.2
BOT CHORD 2x4 SP No.2
OTHERS 2x4 SP No.3

BRACING
TOP CHORD Structural wood sheathing directly applied or 6-0-0 oc purlins.
BOT CHORD Rigid ceiling directly applied or 10-0-0 oc bracing.

REACTIONS (size) 1=9-10-4, 3=9-10-4, 4=9-10-4
Max Horiz 1=73 (LC 11)
Max Uplift 1=-22 (LC 13), 3=-31 (LC 13)
Max Grav 1=209 (LC 1), 3=209 (LC 1), 4=310 (LC 1)

FORCES (lb) - Maximum Compression/Maximum Tension
TOP CHORD 1-2=-135/62, 2-3=-130/50
BOT CHORD 1-4=-14/61, 3-4=-14/61
WEBS 2-4=-197/40

- NOTES**
- 1) Unbalanced roof live loads have been considered for this design.
 - 2) Wind: ASCE 7-10; Vult=115mph (3-second gust) Vasd=91mph; TCDL=6.0psf; BCDL=6.0psf; h=30ft; Cat. II; Exp B; Enclosed; MWFRS (envelope) exterior zone and C-C Exterior (2) zone; cantilever left and right exposed; end vertical left and right exposed; C-C for members and forces & MWFRS for reactions shown; Lumber DOL=1.60 plate grip DOL=1.60
 - 3) Truss designed for wind loads in the plane of the truss only. For studs exposed to wind (normal to the face), see Standard Industry Gable End Details as applicable, or consult qualified building designer as per ANSI/TPI 1.
 - 4) Gable requires continuous bottom chord bearing.
 - 5) Gable studs spaced at 4-0-0 oc.
 - 6) This truss has been designed for a 10.0 psf bottom chord live load nonconcurrent with any other live loads.

- 7) * This truss has been designed for a live load of 20.0psf on the bottom chord in all areas where a rectangle 3-06-00 tall by 1-00-00 wide will fit between the bottom chord and any other members.
 - 8) Provide mechanical connection (by others) of truss to bearing plate capable of withstanding 22 lb uplift at joint 1 and 31 lb uplift at joint 3.
 - 9) This truss is designed in accordance with the 2015 International Residential Code sections R502.11.1 and R802.10.2 and referenced standard ANSI/TPI 1.
- LOAD CASE(S)** Standard



January 17, 2023

WARNING - Verify design parameters and READ NOTES ON THIS AND INCLUDED MITEK REFERENCE PAGE MII-7473 rev. 5/19/2020 BEFORE USE.

Design valid for use only with MiTek® connectors. This design is based only upon parameters shown, and is for an individual building component, not a truss system. Before use, the building designer must verify the applicability of design parameters and properly incorporate this design into the overall building design. Bracing indicated is to prevent buckling of individual truss web and/or chord members only. Additional temporary and permanent bracing is always required for stability and to prevent collapse with possible personal injury and property damage. For general guidance regarding the fabrication, storage, delivery, erection and bracing of trusses and truss systems, see **ANSI/TPI1 Quality Criteria, DSB-89 and BCSI Building Component Safety Information** available from Truss Plate Institute, 2670 Crain Highway, Suite 203 Waldorf, MD 20601

ENGINEERING BY
TRENCO
A MiTek Affiliate

818 Soundside Road
Edenton, NC 27932

Job 36029A	Truss V12	Truss Type Valley	Qty 1	Ply 1	57 SERENITY Job Reference (optional)	156131992
---------------	--------------	----------------------	----------	----------	---	-----------

84 Components (Dunn), Dunn, NC - 28334,

Run: 8.63 S Nov 19 2022 Print: 8.630 S Nov 19 2022 MiTek Industries, Inc. Fri Jan 13 10:17:15
ID:Yx2rTE1Bsg3FMTxHAn5yLly6LMe-RfC?PsB70Hq3NSgPqnL8w3uITxbGKWrCDoi7J4zJC?f

Page: 1

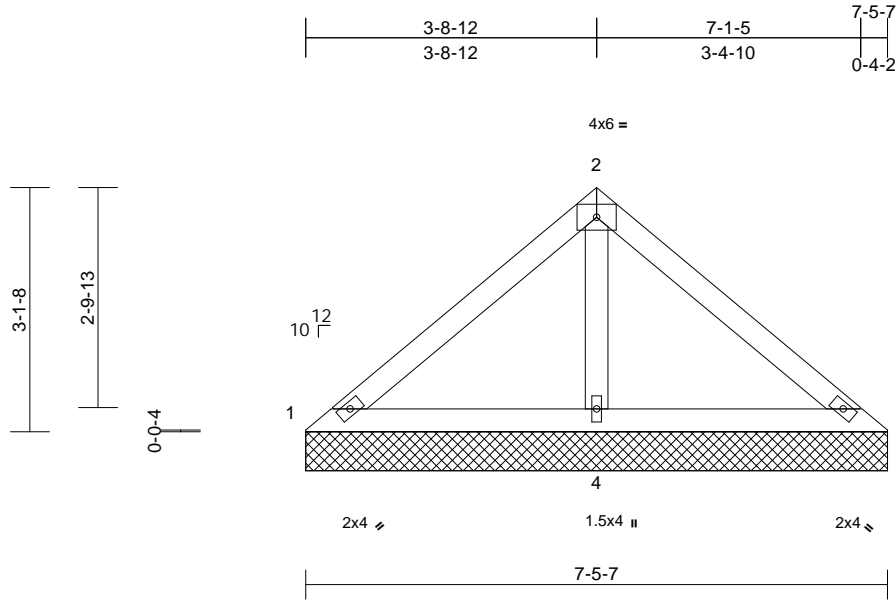

Loading	(psf)	Spacing	2-0-0	CSI	DEFL	in	(loc)	l/defl	L/d	PLATES	GRIP	
TCLL (roof)	20.0	Plate Grip DOL	1.15	TC	0.29	Vert(LL)	n/a	-	n/a	999	MT20	244/190
TCDL	10.0	Lumber DOL	1.15	BC	0.18	Vert(TL)	n/a	-	n/a	999		
BCLL	0.0*	Rep Stress Incr	YES	WB	0.09	Horiz(TL)	0.00	3	n/a	n/a		
BCDL	10.0	Code	IRC2015/TPI2014	Matrix-MP							Weight: 28 lb	FT = 20%

LUMBER
TOP CHORD 2x4 SP No.3
BOT CHORD 2x4 SP No.2
OTHERS 2x4 SP No.3

BRACING
TOP CHORD Structural wood sheathing directly applied or 7-5-7 oc purlins.
BOT CHORD Rigid ceiling directly applied or 6-0-0 oc bracing.

REACTIONS (size) 1=7-5-7, 3=7-5-7, 4=7-5-7
Max Horiz 1=-57 (LC 8)
Max Uplift 1=-8 (LC 24), 3=-8 (LC 23), 4=-37 (LC 12)
Max Grav 1=66 (LC 23), 3=66 (LC 24), 4=519 (LC 1)

FORCES (lb) - Maximum Compression/Maximum Tension
TOP CHORD 1-2=-48/200, 2-3=-48/200
BOT CHORD 1-4=-157/87, 3-4=-157/87
WEBS 2-4=-367/94

- 7) * This truss has been designed for a live load of 20.0psf on the bottom chord in all areas where a rectangle 3-06-00 tall by 1-00-00 wide will fit between the bottom chord and any other members.
- 8) Provide mechanical connection (by others) of truss to bearing plate capable of withstanding 8 lb uplift at joint 1, 8 lb uplift at joint 3 and 37 lb uplift at joint 4.
- 9) This truss is designed in accordance with the 2015 International Residential Code sections R502.11.1 and R802.10.2 and referenced standard ANSI/TPI 1.
- LOAD CASE(S)** Standard

- NOTES**
- Unbalanced roof live loads have been considered for this design.
 - Wind: ASCE 7-10; Vult=115mph (3-second gust) Vasd=91mph; TC DL=6.0psf; BC DL=6.0psf; h=30ft; Cat. II; Exp B; Enclosed; MWFRS (envelope) exterior zone and C-C Exterior (2) zone; cantilever left and right exposed; end vertical left and right exposed; C-C for members and forces & MWFRS for reactions shown; Lumber DOL=1.60 plate grip DOL=1.60
 - Truss designed for wind loads in the plane of the truss only. For studs exposed to wind (normal to the face), see Standard Industry Gable End Details as applicable, or consult qualified building designer as per ANSI/TPI 1.
 - Gable requires continuous bottom chord bearing.
 - Gable studs spaced at 2-0-0 oc.
 - This truss has been designed for a 10.0 psf bottom chord live load nonconcurrent with any other live loads.

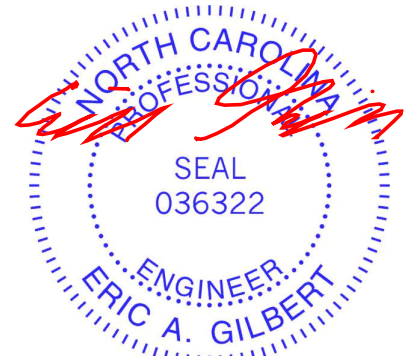

January 17, 2023

WARNING - Verify design parameters and READ NOTES ON THIS AND INCLUDED MITEK REFERENCE PAGE MII-7473 rev. 5/19/2020 BEFORE USE.

Design valid for use only with MiTek® connectors. This design is based only upon parameters shown, and is for an individual building component, not a truss system. Before use, the building designer must verify the applicability of design parameters and properly incorporate this design into the overall building design. Bracing indicated is to prevent buckling of individual truss web and/or chord members only. Additional temporary and permanent bracing is always required for stability and to prevent collapse with possible personal injury and property damage. For general guidance regarding the fabrication, storage, delivery, erection and bracing of trusses and truss systems, see

ANSI/TPI1 Quality Criteria, DSB-89 and BCSI Building Component

Safety Information available from Truss Plate Institute, 2670 Crain Highway, Suite 203 Waldorf, MD 20601

ENGINEERING BY
TRENCO
A MiTek Affiliate

818 Soundside Road
Edenton, NC 27932

Job 36029A	Truss V13	Truss Type Valley	Qty 1	Ply 1	57 SERENITY Job Reference (optional)	156131993
---------------	--------------	----------------------	----------	----------	---	-----------

84 Components (Dunn), Dunn, NC - 28334,

Run: 8.63 S Nov 19 2022 Print: 8.630 S Nov 19 2022 MiTek Industries, Inc. Fri Jan 13 10:17:15
ID:cNWNl_dwKkFJk?BhYaURq4y6LLt-RfC?PsB70Hq3NSgPqnL8w3uITXbGKWrCDoi7J4zJC?F

Page: 1

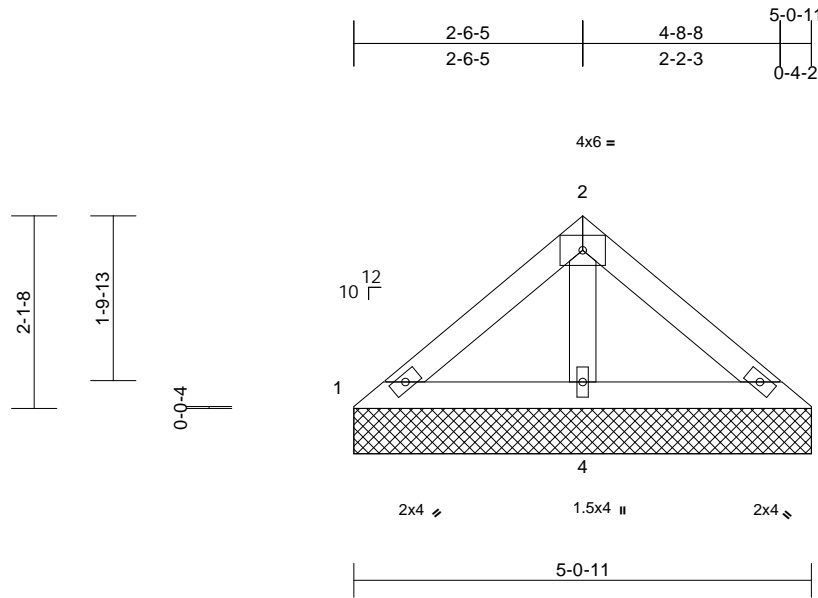

Scale = 1:25.5

Loading	(psf)	Spacing	2-0-0	CSI	DEFL	in	(loc)	l/defl	L/d	PLATES	GRIP	
TCLL (roof)	20.0	Plate Grip DOL	1.15	TC	0.11	Vert(LL)	n/a	-	n/a	999	MT20	244/190
TCDL	10.0	Lumber DOL	1.15	BC	0.14	Vert(TL)	n/a	-	n/a	999		
BCLL	0.0*	Rep Stress Incr	YES	WB	0.04	Horiz(TL)	0.00	3	n/a	n/a		
BCDL	10.0	Code	IRC2015/TPI2014	Matrix-MP							Weight: 18 lb	FT = 20%

LUMBER

TOP CHORD 2x4 SP No.3
BOT CHORD 2x4 SP No.3
OTHERS 2x4 SP No.3

BRACING

TOP CHORD Structural wood sheathing directly applied or 5-0-11 oc purlins.
BOT CHORD Rigid ceiling directly applied or 6-0-0 oc bracing.

REACTIONS (size) 1=5-0-11, 3=5-0-11, 4=5-0-11
Max Horiz 1=37 (LC 11)
Max Uplift 3=-3 (LC 13), 4=-14 (LC 12)
Max Grav 1=62 (LC 23), 3=62 (LC 24), 4=306 (LC 1)

FORCES (lb) - Maximum Compression/Maximum Tension

TOP CHORD 1-2=-55/97, 2-3=-55/97
BOT CHORD 1-4=-77/48, 3-4=-77/48
WEBS 2-4=-193/41

NOTES

- Unbalanced roof live loads have been considered for this design.
- Wind: ASCE 7-10; Vult=115mph (3-second gust) Vasd=91mph; TCCL=6.0psf; BCDL=6.0psf; h=30ft; Cat. II; Exp B; Enclosed; MWFRS (envelope) exterior zone and C-C Exterior (2) zone; cantilever left and right exposed; end vertical left and right exposed; C-C for members and forces & MWFRS for reactions shown; Lumber DOL=1.60 plate grip DOL=1.60
- Truss designed for wind loads in the plane of the truss only. For studs exposed to wind (normal to the face), see Standard Industry Gable End Details as applicable, or consult qualified building designer as per ANSI/TPI 1.
- Gable requires continuous bottom chord bearing.
- Gable studs spaced at 2-0-0 oc.
- This truss has been designed for a 10.0 psf bottom chord live load nonconcurrent with any other live loads.

- * This truss has been designed for a live load of 20.0psf on the bottom chord in all areas where a rectangle 3-06-00 tall by 1-00-00 wide will fit between the bottom chord and any other members.
- Provide mechanical connection (by others) of truss to bearing plate capable of withstanding 3 lb uplift at joint 3 and 14 lb uplift at joint 4.
- This truss is designed in accordance with the 2015 International Residential Code sections R502.11.1 and R802.10.2 and referenced standard ANSI/TPI 1.

LOAD CASE(S) Standard

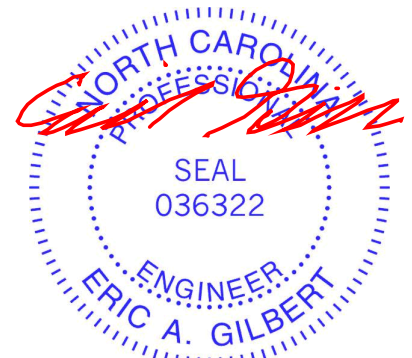

January 17, 2023

WARNING - Verify design parameters and READ NOTES ON THIS AND INCLUDED MITEK REFERENCE PAGE MII-7473 rev. 5/19/2020 BEFORE USE.

Design valid for use only with MiTek® connectors. This design is based only upon parameters shown, and is for an individual building component, not a truss system. Before use, the building designer must verify the applicability of design parameters and properly incorporate this design into the overall building design. Bracing indicated is to prevent buckling of individual truss web and/or chord members only. Additional temporary and permanent bracing is always required for stability and to prevent collapse with possible personal injury and property damage. For general guidance regarding the fabrication, storage, delivery, erection and bracing of trusses and truss systems, see **ANSI/TPI1 Quality Criteria, DSB-89 and BCSI Building Component Safety Information** available from Truss Plate Institute, 2670 Crain Highway, Suite 203 Waldorf, MD 20601

ENGINEERING BY
TRENCO
A MiTek Affiliate

818 Soundside Road
Edenton, NC 27932

Job 36029A	Truss V15	Truss Type Valley	Qty 1	Ply 1	57 SERENITY Job Reference (optional)	156131994
---------------	--------------	----------------------	----------	----------	---	-----------

84 Components (Dunn), Dunn, NC - 28334,

Run: 8.63 S Nov 19 2022 Print: 8.630 S Nov 19 2022 MiTek Industries, Inc. Fri Jan 13 10:17:16
 ID:5smkx04C3bMH7SMmandainy6LK?-RfC?PsB70Hq3NSgPqnL8w3uITXbGKWrCDoi7J4zJC?f

Page: 1

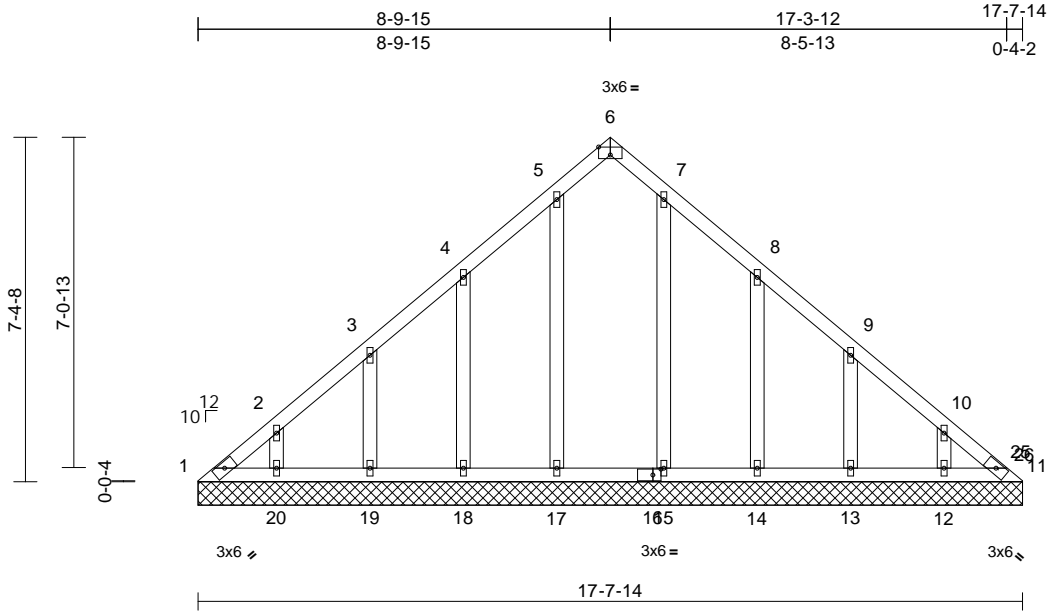

Scale = 1:49.3

Plate Offsets (X, Y): [6:0-3-0,Edge], [16:0-2-1,0-1-8]

Loading	(psf)	Spacing	2-0-0	CSI	DEFL	in	(loc)	l/defl	L/d	PLATES	GRIP	
TCLL (roof)	20.0	Plate Grip DOL	1.15	TC	0.05	Vert(LL)	n/a	-	n/a	999	MT20	244/190
TCDL	10.0	Lumber DOL	1.15	BC	0.05	Vert(TL)	n/a	-	n/a	999		
BCLL	0.0*	Rep Stress Incr	YES	WB	0.08	Horiz(TL)	0.00	11	n/a	n/a		
BCDL	10.0	Code	IRC2015/TPI2014	Matrix-MS							Weight: 99 lb	FT = 20%

LUMBER
 TOP CHORD 2x4 SP No.2
 BOT CHORD 2x4 SP No.2
 OTHERS 2x4 SP No.3

BRACING
 TOP CHORD Structural wood sheathing directly applied or 6-0-0 oc purlins.
 BOT CHORD Rigid ceiling directly applied or 10-0-0 oc bracing.

REACTIONS (size)
 1=17-7-14, 11=17-7-14,
 12=17-7-14, 13=17-7-14,
 14=17-7-14, 15=17-7-14,
 17=17-7-14, 18=17-7-14,
 19=17-7-14, 20=17-7-14
 Max Horiz 1=139 (LC 9)
 Max Uplift 1=-24 (LC 10), 11=-11 (LC 11),
 12=-11 (LC 13), 13=-60 (LC 13),
 14=-67 (LC 13), 17=-9 (LC 12),
 18=-65 (LC 12), 19=-59 (LC 12),
 20=-21 (LC 12)
 Max Grav 1=106 (LC 21), 11=92 (LC 13),
 12=165 (LC 1), 13=166 (LC 20),
 14=200 (LC 20), 15=212 (LC 20),
 17=230 (LC 19), 18=197 (LC 19),
 19=164 (LC 19), 20=173 (LC 19)

FORCES (lb) - Maximum Compression/Maximum Tension
 TOP CHORD 1-2=-197/133, 2-3=-155/95, 3-4=-102/58,
 4-5=-82/41, 5-6=-61/45, 6-7=-61/45,
 7-8=-69/27, 8-9=-93/42, 9-10=-143/95,
 10-11=-182/132
 BOT CHORD 1-20=-105/157, 19-20=-105/157,
 18-19=-105/157, 17-18=-105/157,
 15-17=-105/157, 14-15=-105/157,
 13-14=-105/157, 12-13=-105/157,
 11-12=-105/157

WEBS 5-17=-118/35, 7-15=-108/24, 4-18=-132/89,
 3-19=-129/81, 2-20=-118/54, 8-14=-132/91,
 9-13=-130/81, 10-12=-113/50

- NOTES**
- 1) Unbalanced roof live loads have been considered for this design.
 - 2) Wind: ASCE 7-10; Vult=115mph (3-second gust) Vasd=91mph; TC DL=6.0psf; BCDL=6.0psf; h=30ft; Cat. II; Exp B; Enclosed; MWFRS (envelope) exterior zone and C-C Corner (3) 0-0-5 to 4-6-11, Exterior (2) 4-6-11 to 8-10-4, Corner (3) 8-10-4 to 13-4-10, Exterior (2) 13-4-10 to 17-3-10 zone; cantilever left and right exposed; end vertical left and right exposed; C-C for members and forces & MWFRS for reactions shown; Lumber DOL=1.60 plate grip DOL=1.60
 - 3) Truss designed for wind loads in the plane of the truss only. For studs exposed to wind (normal to the face), see Standard Industry Gable End Details as applicable, or consult qualified building designer as per ANSI/TPI 1.
 - 4) All plates are 1.5x4 MT20 unless otherwise indicated.
 - 5) Gable requires continuous bottom chord bearing.
 - 6) Gable studs spaced at 2-0-0 oc.
 - 7) This truss has been designed for a 10.0 psf bottom chord live load nonconcurrent with any other live loads.
 - 8) * This truss has been designed for a live load of 20.0psf on the bottom chord in all areas where a rectangle 3-06-00 tall by 1-00-00 wide will fit between the bottom chord and any other members, with BCDL = 10.0psf.
 - 9) Provide mechanical connection (by others) of truss to bearing plate capable of withstanding 24 lb uplift at joint 1, 11 lb uplift at joint 11, 9 lb uplift at joint 17, 65 lb uplift at joint 18, 59 lb uplift at joint 19, 21 lb uplift at joint 20, 67 lb uplift at joint 14, 60 lb uplift at joint 13 and 11 lb uplift at joint 12.
 - 10) This truss is designed in accordance with the 2015 International Residential Code sections R502.11.1 and R802.10.2 and referenced standard ANSI/TPI 1.

LOAD CASE(S) Standard

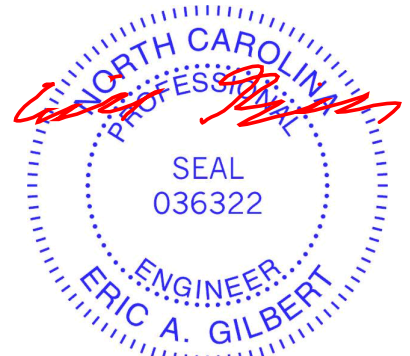

January 17, 2023

WARNING - Verify design parameters and READ NOTES ON THIS AND INCLUDED MITEK REFERENCE PAGE MII-7473 rev. 5/19/2020 BEFORE USE.

Design valid for use only with MiTek® connectors. This design is based only upon parameters shown, and is for an individual building component, not a truss system. Before use, the building designer must verify the applicability of design parameters and properly incorporate this design into the overall building design. Bracing indicated is to prevent buckling of individual truss web and/or chord members only. Additional temporary and permanent bracing is always required for stability and to prevent collapse with possible personal injury and property damage. For general guidance regarding the fabrication, storage, delivery, erection and bracing of trusses and truss systems, see **ANSI/TPI1 Quality Criteria, DSB-89 and BCSI Building Component Safety Information** available from Truss Plate Institute, 2670 Crain Highway, Suite 203 Waldorf, MD 20601



818 Soundside Road
 Edenton, NC 27932

Job 36029A	Truss V16	Truss Type Valley	Qty 1	Ply 1	57 SERENITY Job Reference (optional)	156131995
---------------	--------------	----------------------	----------	----------	---	-----------

84 Components (Dunn), Dunn, NC - 28334,

Run: 8.63 S Nov 19 2022 Print: 8.630 S Nov 19 2022 MiTek Industries, Inc. Fri Jan 13 10:17:16
ID: ?ODfKum05c?Qwz3gnA8PNvy6LHp-RfC?PsB70Hq3NSgPqnL8w3uTXbGKwRCDoi7J4zJC?f

Page: 1

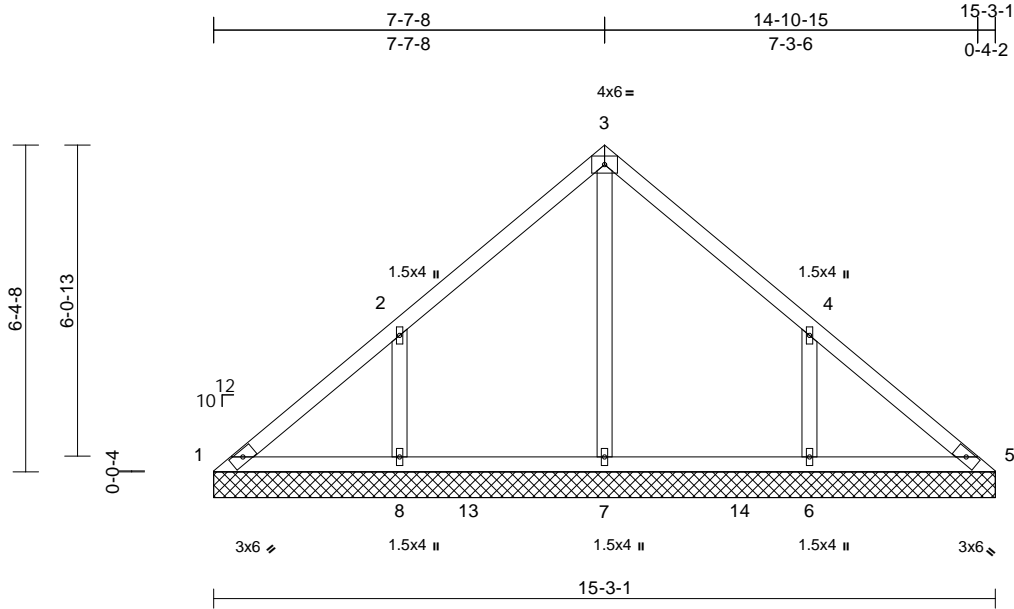

Scale = 1:45

Loading	(psf)	Spacing	2-0-0	CSI	DEFL	in	(loc)	l/defl	L/d	PLATES	GRIP	
TCLL (roof)	20.0	Plate Grip DOL	1.15	TC	0.23	Vert(LL)	n/a	-	n/a	999	MT20	244/190
TCDL	10.0	Lumber DOL	1.15	BC	0.16	Vert(TL)	n/a	-	n/a	999		
BCLL	0.0*	Rep Stress Incr	YES	WB	0.15	Horiz(TL)	0.00	5	n/a	n/a		
BCDL	10.0	Code	IRC2015/TPI2014	Matrix-MP							Weight: 67 lb	FT = 20%

LUMBER

TOP CHORD 2x4 SP No.2
BOT CHORD 2x4 SP No.2
OTHERS 2x4 SP No.3

BRACING

TOP CHORD Structural wood sheathing directly applied or 10-0-0 oc purlins.
BOT CHORD Rigid ceiling directly applied or 6-0-0 oc bracing.

REACTIONS

(size) 1=15-3-1, 5=15-3-1, 6=15-3-1, 7=15-3-1, 8=15-3-1
Max Horiz 1=120 (LC 9)
Max Uplift 1=-14 (LC 8), 6=-125 (LC 13), 8=-127 (LC 12)
Max Grav 1=112 (LC 20), 5=95 (LC 24), 6=407 (LC 20), 7=392 (LC 19), 8=409 (LC 19)

FORCES

(lb) - Maximum Compression/Maximum Tension

TOP CHORD 1-2=-134/149, 2-3=-91/104, 3-4=-72/93, 4-5=-111/118
BOT CHORD 1-8=-85/114, 7-8=-85/91, 6-7=-85/91, 5-6=-85/91
WEBS 3-7=-218/0, 2-8=-288/168, 4-6=-286/167

NOTES

- Unbalanced roof live loads have been considered for this design.
- Wind: ASCE 7-10; Vult=115mph (3-second gust) Vasd=91mph; TCDL=6.0psf; BCDL=6.0psf; h=30ft; Cat. II; Exp B; Enclosed; MWFRS (envelope) exterior zone and C-C Corner (3) 0-0-5 to 4-6-11, Exterior (2) 4-6-11 to 7-7-13, Corner (3) 7-7-13 to 12-2-4, Exterior (2) 12-2-4 to 15-3-6 zone; cantilever left and right exposed; end vertical left and right exposed; C-C for members and forces & MWFRS for reactions shown; Lumber DOL=1.60 plate grip DOL=1.60
- Truss designed for wind loads in the plane of the truss only. For studs exposed to wind (normal to the face), see Standard Industry Gable End Details as applicable, or consult qualified building designer as per ANSI/TPI 1.

- Gable requires continuous bottom chord bearing.
 - Gable studs spaced at 4-0-0 oc.
 - This truss has been designed for a 10.0 psf bottom chord live load nonconcurrent with any other live loads.
 - * This truss has been designed for a live load of 20.0psf on the bottom chord in all areas where a rectangle 3-06-00 tall by 1-00-00 wide will fit between the bottom chord and any other members, with BCDL = 10.0psf.
 - Provide mechanical connection (by others) of truss to bearing plate capable of withstanding 14 lb uplift at joint 1, 127 lb uplift at joint 8 and 125 lb uplift at joint 6.
 - This truss is designed in accordance with the 2015 International Residential Code sections R502.11.1 and R802.10.2 and referenced standard ANSI/TPI 1.
- LOAD CASE(S)** Standard

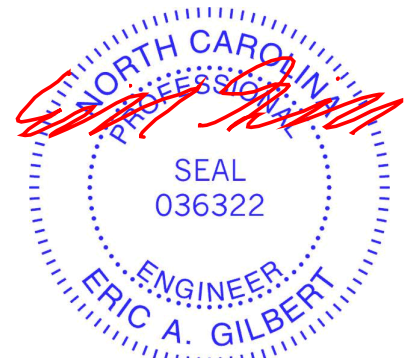

January 17, 2023

WARNING - Verify design parameters and READ NOTES ON THIS AND INCLUDED MITEK REFERENCE PAGE MII-7473 rev. 5/19/2020 BEFORE USE.

Design valid for use only with MiTek® connectors. This design is based only upon parameters shown, and is for an individual building component, not a truss system. Before use, the building designer must verify the applicability of design parameters and properly incorporate this design into the overall building design. Bracing indicated is to prevent buckling of individual truss web and/or chord members only. Additional temporary and permanent bracing is always required for stability and to prevent collapse with possible personal injury and property damage. For general guidance regarding the fabrication, storage, delivery, erection and bracing of trusses and truss systems, see **ANSI/TPI1 Quality Criteria, DSB-89 and BCSI Building Component Safety Information** available from Truss Plate Institute, 2670 Crain Highway, Suite 203 Waldorf, MD 20601



818 Soundside Road
Edenton, NC 27932

Job 36029A	Truss V17	Truss Type Valley	Qty 1	Ply 1	57 SERENITY Job Reference (optional)	156131996
---------------	--------------	----------------------	----------	----------	---	-----------

84 Components (Dunn), Dunn, NC - 28334,

Run: 8.63 S Nov 19 2022 Print: 8.630 S Nov 19 2022 MiTek Industries, Inc. Fri Jan 13 10:17:16
ID:iJqRQJulkhG?7VqbMHKInOy6LHF-RfC?PsB70Hq3NSgPqnL8w3ulTXbGKWRcDoi7J4zJC?f

Page: 1

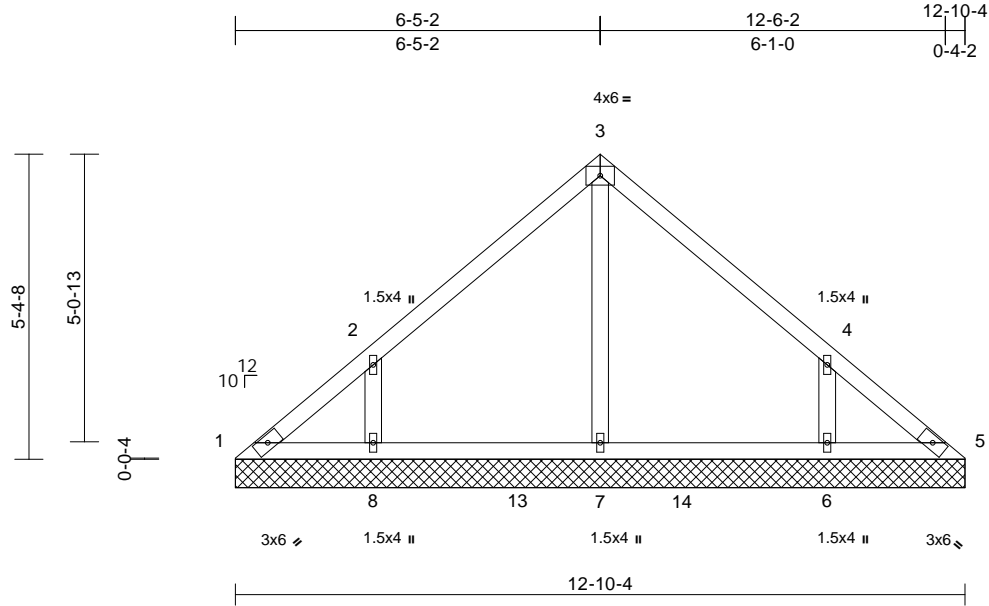

Loading	(psf)	Spacing	2-0-0	CSI	DEFL	in	(loc)	l/defl	L/d	PLATES	GRIP	
TCLL (roof)	20.0	Plate Grip DOL	1.15	TC	0.22	Vert(LL)	n/a	-	n/a	999	MT20	244/190
TCDL	10.0	Lumber DOL	1.15	BC	0.12	Vert(TL)	n/a	-	n/a	999		
BCLL	0.0*	Rep Stress Incr	YES	WB	0.07	Horiz(TL)	0.00	5	n/a	n/a		
BCDL	10.0	Code	IRC2015/TPI2014	Matrix-MP							Weight: 54 lb	FT = 20%

LUMBER
TOP CHORD 2x4 SP No.2
BOT CHORD 2x4 SP No.2
OTHERS 2x4 SP No.3

BRACING
TOP CHORD Structural wood sheathing directly applied or 6-0-0 oc purlins.
BOT CHORD Rigid ceiling directly applied or 10-0-0 oc bracing.

REACTIONS (size) 1=12-10-4, 5=12-10-4, 6=12-10-4, 7=12-10-4, 8=12-10-4
Max Horiz 1=100 (LC 10)
Max Uplift 1=-20 (LC 8), 6=-110 (LC 13), 8=-113 (LC 12)
Max Grav 1=92 (LC 20), 5=73 (LC 19), 6=344 (LC 20), 7=299 (LC 19), 8=347 (LC 19)

FORCES (lb) - Maximum Compression/Maximum Tension
TOP CHORD 1-2=-113/94, 2-3=-136/94, 3-4=-130/89, 4-5=-92/64
BOT CHORD 1-8=-31/82, 7-8=-31/68, 6-7=-31/68, 5-6=-31/71
WEBS 3-7=-145/0, 2-8=-275/163, 4-6=-274/162

NOTES
1) Unbalanced roof live loads have been considered for this design.
2) Wind: ASCE 7-10; Vult=115mph (3-second gust) Vasd=91mph; TCCL=6.0psf; BCDL=6.0psf; h=30ft; Cat. II; Exp B; Enclosed; MWFRS (envelope) exterior zone and C-C Corner (3) 0-0-5 to 4-6-11, Exterior (2) 4-6-11 to 6-5-7, Corner (3) 6-5-7 to 10-11-13, Exterior (2) 10-11-13 to 12-10-9 zone; cantilever left and right exposed; end vertical left and right exposed; C-C for members and forces & MWFRS for reactions shown; Lumber DOL=1.60 plate grip DOL=1.60
3) Truss designed for wind loads in the plane of the truss only. For studs exposed to wind (normal to the face), see Standard Industry Gable End Details as applicable, or consult qualified building designer as per ANSI/TPI 1.

- Gable requires continuous bottom chord bearing.
 - Gable studs spaced at 4-0-0 oc.
 - This truss has been designed for a 10.0 psf bottom chord live load nonconcurrent with any other live loads.
 - * This truss has been designed for a live load of 20.0psf on the bottom chord in all areas where a rectangle 3-06-00 tall by 1-00-00 wide will fit between the bottom chord and any other members, with BCDL = 10.0psf.
 - Provide mechanical connection (by others) of truss to bearing plate capable of withstanding 20 lb uplift at joint 1, 113 lb uplift at joint 8 and 110 lb uplift at joint 6.
 - This truss is designed in accordance with the 2015 International Residential Code sections R502.11.1 and R802.10.2 and referenced standard ANSI/TPI 1.
- LOAD CASE(S)** Standard



January 17, 2023

WARNING - Verify design parameters and READ NOTES ON THIS AND INCLUDED MITEK REFERENCE PAGE MII-7473 rev. 5/19/2020 BEFORE USE.

Design valid for use only with MiTek® connectors. This design is based only upon parameters shown, and is for an individual building component, not a truss system. Before use, the building designer must verify the applicability of design parameters and properly incorporate this design into the overall building design. Bracing indicated is to prevent buckling of individual truss web and/or chord members only. Additional temporary and permanent bracing is always required for stability and to prevent collapse with possible personal injury and property damage. For general guidance regarding the fabrication, storage, delivery, erection and bracing of trusses and truss systems, see **ANSI/TPI1 Quality Criteria, DSB-89 and BCSI Building Component Safety Information** available from Truss Plate Institute, 2670 Crain Highway, Suite 203 Waldorf, MD 20601



818 Soundside Road
Edenton, NC 27932

Job 36029A	Truss V18	Truss Type Valley	Qty 1	Ply 1	57 SERENITY Job Reference (optional)	156131997
---------------	--------------	----------------------	----------	----------	---	-----------

84 Components (Dunn), Dunn, NC - 28334,

Run: 8.63 S Nov 19 2022 Print: 8.630 S Nov 19 2022 MiTek Industries, Inc. Fri Jan 13 10:17:17
ID:fzTdPo6CGxfivQnE_m9C20y6LHM-RfC?PsB70Hq3NSgPqnL8w3uITXbGKWrCDoi7J4zJC?f

Page: 1

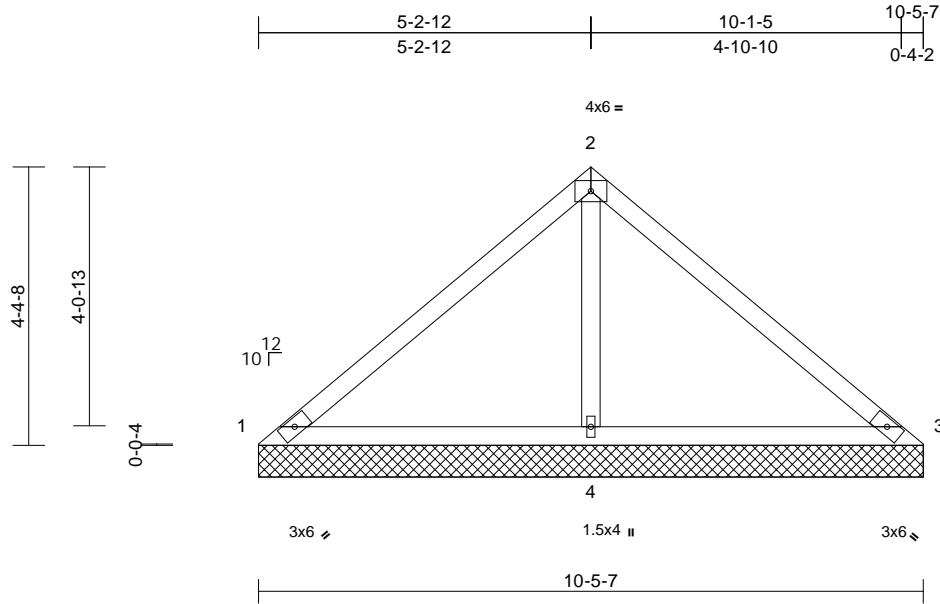

Scale = 1:36.2

Loading	(psf)	Spacing	2-0-0	CSI	DEFL	in	(loc)	l/defl	L/d	PLATES	GRIP	
TCLL (roof)	20.0	Plate Grip DOL	1.15	TC	0.39	Vert(LL)	n/a	-	n/a	999	MT20	244/190
TCDL	10.0	Lumber DOL	1.15	BC	0.33	Vert(TL)	n/a	-	n/a	999		
BCLL	0.0*	Rep Stress Incr	YES	WB	0.23	Horiz(TL)	0.01	3	n/a	n/a		
BCDL	10.0	Code	IRC2015/TPI2014	Matrix-MP							Weight: 40 lb	FT = 20%

LUMBER

TOP CHORD 2x4 SP No.2
BOT CHORD 2x4 SP No.2
OTHERS 2x4 SP No.3

BRACING

TOP CHORD Structural wood sheathing directly applied or 10-0-0 oc purlins.
BOT CHORD Rigid ceiling directly applied or 6-0-0 oc bracing.

REACTIONS

(size) 1=10-5-7, 3=10-5-7, 4=10-5-7
Max Horiz 1=-81 (LC 8)
Max Uplift 1=-58 (LC 24), 3=-58 (LC 23), 4=-84 (LC 12)
Max Grav 1=46 (LC 23), 3=50 (LC 12), 4=855 (LC 1)

FORCES

(lb) - Maximum Compression/Maximum Tension

TOP CHORD 1-2=-107/388, 2-3=-107/388
BOT CHORD 1-4=-298/148, 3-4=-298/148
WEBS 2-4=-659/181

NOTES

- 1) Unbalanced roof live loads have been considered for this design.
- 2) Wind: ASCE 7-10; Vult=115mph (3-second gust) Vasd=91mph; TCCL=6.0psf; BCDL=6.0psf; h=30ft; Cat. II; Exp B; Enclosed; MWFRS (envelope) exterior zone and C-C Corner (3) 0-0-5 to 4-6-11, Exterior (2) 4-6-11 to 5-3-0, Corner (3) 5-3-0 to 9-8-6, Exterior (2) 9-8-6 to 10-5-12 zone; cantilever left and right exposed; end vertical left and right exposed; C-C for members and forces & MWFRS for reactions shown; Lumber DOL=1.60 plate grip DOL=1.60
- 3) Truss designed for wind loads in the plane of the truss only. For studs exposed to wind (normal to the face), see Standard Industry Gable End Details as applicable, or consult qualified building designer as per ANSI/TPI 1.
- 4) Gable requires continuous bottom chord bearing.
- 5) Gable studs spaced at 4-0-0 oc.

- 6) This truss has been designed for a 10.0 psf bottom chord live load nonconcurrent with any other live loads.
- 7) * This truss has been designed for a live load of 20.0psf on the bottom chord in all areas where a rectangle 3-06-00 tall by 1-00-00 wide will fit between the bottom chord and any other members.
- 8) Provide mechanical connection (by others) of truss to bearing plate capable of withstanding 58 lb uplift at joint 1, 58 lb uplift at joint 3 and 84 lb uplift at joint 4.
- 9) This truss is designed in accordance with the 2015 International Residential Code sections R502.11.1 and R802.10.2 and referenced standard ANSI/TPI 1.

LOAD CASE(S) Standard

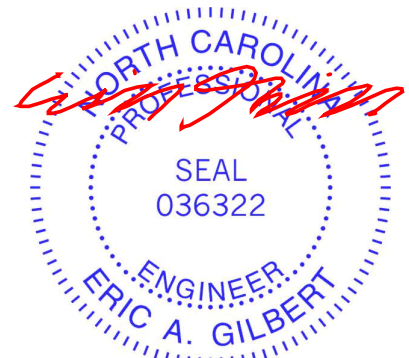

January 17, 2023

WARNING - Verify design parameters and READ NOTES ON THIS AND INCLUDED MITEK REFERENCE PAGE MII-7473 rev. 5/19/2020 BEFORE USE.

Design valid for use only with MiTek® connectors. This design is based only upon parameters shown, and is for an individual building component, not a truss system. Before use, the building designer must verify the applicability of design parameters and properly incorporate this design into the overall building design. Bracing indicated is to prevent buckling of individual truss web and/or chord members only. Additional temporary and permanent bracing is always required for stability and to prevent collapse with possible personal injury and property damage. For general guidance regarding the fabrication, storage, delivery, erection and bracing of trusses and truss systems, see

Safety Information available from Truss Plate Institute, 2670 Crain Highway, Suite 203 Waldorf, MD 20601

ANSI/TPI1 Quality Criteria, DSB-89 and BCSI Building Component



818 Soundside Road
Edenton, NC 27932

Job 36029A	Truss V19	Truss Type Valley	Qty 1	Ply 1	57 SERENITY Job Reference (optional)	156131998
---------------	--------------	----------------------	----------	----------	---	-----------

84 Components (Dunn), Dunn, NC - 28334,

Run: 8.63 S Nov 19 2022 Print: 8.630 S Nov 19 2022 MiTek Industries, Inc. Fri Jan 13 10:17:17
ID:UOMKEgOerbY19y1fq54cUty6LH?-RfC?PsB70Hq3NSgPqnL8w3uITXbGKWrCDoi7J4zJC?F

Page: 1

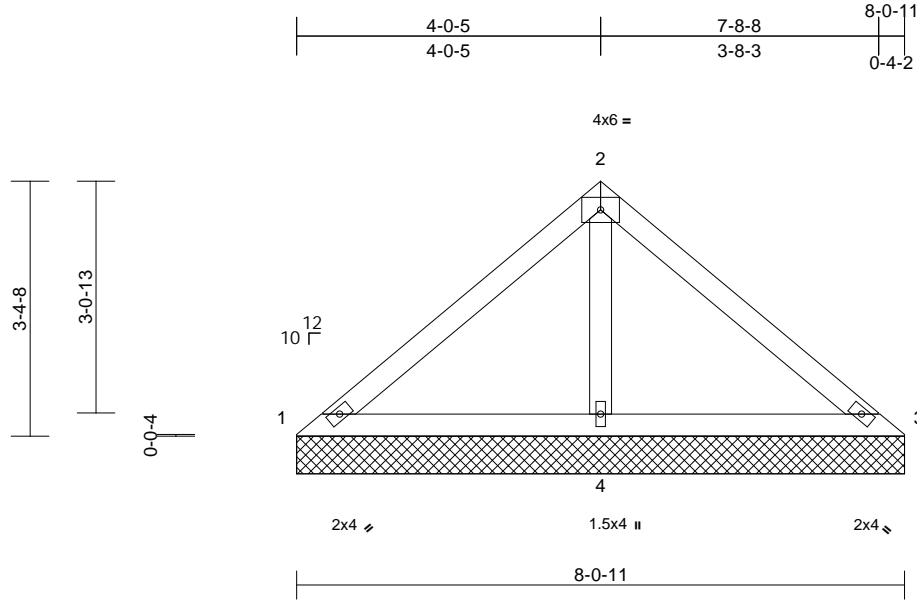

Scale = 1:30.5

Loading	(psf)	Spacing	2-0-0	CSI	DEFL	in	(loc)	l/defl	L/d	PLATES	GRIP	
TCLL (roof)	20.0	Plate Grip DOL	1.15	TC	0.35	Vert(LL)	n/a	-	n/a	999	MT20	244/190
TCDL	10.0	Lumber DOL	1.15	BC	0.21	Vert(TL)	n/a	-	n/a	999		
BCLL	0.0*	Rep Stress Incr	YES	WB	0.11	Horiz(TL)	0.00	3	n/a	n/a		
BCDL	10.0	Code	IRC2015/TPI2014	Matrix-MP							Weight: 30 lb	FT = 20%

LUMBER

TOP CHORD 2x4 SP No.3
BOT CHORD 2x4 SP No.2
OTHERS 2x4 SP No.3

BRACING

TOP CHORD Structural wood sheathing directly applied or 8-0-11 oc purlins.
BOT CHORD Rigid ceiling directly applied or 6-0-0 oc bracing.

REACTIONS

(size) 1=8-0-11, 3=8-0-11, 4=8-0-11
Max Horiz 1=62 (LC 11)
Max Uplift 1=-16 (LC 24), 3=-16 (LC 23), 4=-45 (LC 12)
Max Grav 1=64 (LC 23), 3=64 (LC 24), 4=580 (LC 1)

FORCES

(lb) - Maximum Compression/Maximum Tension

TOP CHORD 1-2=-58/233, 2-3=-58/233
BOT CHORD 1-4=-182/98, 3-4=-182/98
WEBS 2-4=-419/110

NOTES

- Unbalanced roof live loads have been considered for this design.
- Wind: ASCE 7-10; Vult=115mph (3-second gust) Vasd=91mph; TC DL=6.0psf; BCDL=6.0psf; h=30ft; Cat. II; Exp B; Enclosed; MWFRS (envelope) exterior zone and C-C Corner (3) zone; cantilever left and right exposed; end vertical left and right exposed; C-C for members and forces & MWFRS for reactions shown; Lumber DOL=1.60 plate grip DOL=1.60
- Truss designed for wind loads in the plane of the truss only. For studs exposed to wind (normal to the face), see Standard Industry Gable End Details as applicable, or consult qualified building designer as per ANSI/TPI 1.
- Gable requires continuous bottom chord bearing.
- Gable studs spaced at 4-0-0 oc.
- This truss has been designed for a 10.0 psf bottom chord live load nonconcurrent with any other live loads.

- * This truss has been designed for a live load of 20.0psf on the bottom chord in all areas where a rectangle 3-06-00 tall by 1-00-00 wide will fit between the bottom chord and any other members.
- Provide mechanical connection (by others) of truss to bearing plate capable of withstanding 16 lb uplift at joint 1, 16 lb uplift at joint 3 and 45 lb uplift at joint 4.
- This truss is designed in accordance with the 2015 International Residential Code sections R502.11.1 and R802.10.2 and referenced standard ANSI/TPI 1.

LOAD CASE(S) Standard



January 17, 2023

WARNING - Verify design parameters and READ NOTES ON THIS AND INCLUDED MITEK REFERENCE PAGE MII-7473 rev. 5/19/2020 BEFORE USE.

Design valid for use only with MiTek® connectors. This design is based only upon parameters shown, and is for an individual building component, not a truss system. Before use, the building designer must verify the applicability of design parameters and properly incorporate this design into the overall building design. Bracing indicated is to prevent buckling of individual truss web and/or chord members only. Additional temporary and permanent bracing is always required for stability and to prevent collapse with possible personal injury and property damage. For general guidance regarding the fabrication, storage, delivery, erection and bracing of trusses and truss systems, see **ANSI/TPI1 Quality Criteria, DSB-89 and BCSI Building Component Safety Information** available from Truss Plate Institute, 2670 Crain Highway, Suite 203 Waldorf, MD 20601



818 Soundside Road
Edenton, NC 27932

Job	Truss	Truss Type	Qty	Ply	57 SERENITY	I56132000
36029A	V21	Valley	1	1	Job Reference (optional)	

84 Components (Dunn), Dunn, NC - 28334,

Run: 8.63 S Nov 19 2022 Print: 8.630 S Nov 19 2022 MiTek Industries, Inc. Fri Jan 13 10:17:18
ID:7F8iuOyU0jLWh0YVWmvOLay6LGH-RfC?PsB70Hq3NSgPqnL8w3uITxbGKWrCdoi7J4zJC?f

Page: 1

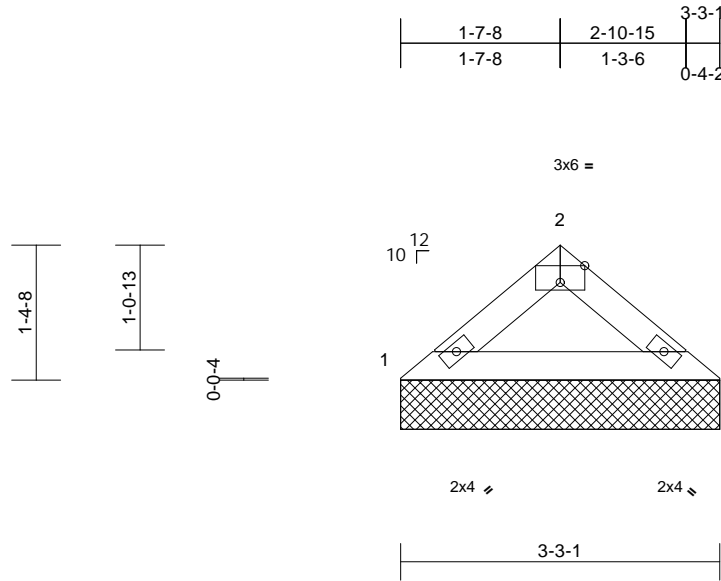

Scale = 1:23.5

Plate Offsets (X, Y): [2:0-3-0,Edge]

Loading	(psf)	Spacing	2-0-0	CSI	DEFL	in	(loc)	l/defl	L/d	PLATES	GRIP	
TCLL (roof)	20.0	Plate Grip DOL	1.15	TC	0.13	Vert(LL)	n/a	-	n/a	999	MT20	244/190
TCDL	10.0	Lumber DOL	1.15	BC	0.11	Vert(TL)	n/a	-	n/a	999		
BCLL	0.0*	Rep Stress Incr	YES	WB	0.00	Horiz(TL)	0.00	3	n/a	n/a		
BCDL	10.0	Code	IRC2015/TPI2014	Matrix-MP							Weight: 10 lb	FT = 20%

LUMBER

TOP CHORD 2x4 SP No.3
BOT CHORD 2x4 SP No.3

BRACING

TOP CHORD Structural wood sheathing directly applied or 3-3-1 oc purlins.
BOT CHORD Rigid ceiling directly applied or 10-0-0 oc bracing.

REACTIONS (size) 1=3-3-1, 3=3-3-1

Max Horiz 1=-23 (LC 10)
Max Uplift 1=-2 (LC 12), 3=-2 (LC 13)
Max Grav 1=130 (LC 1), 3=130 (LC 1)

FORCES (lb) - Maximum Compression/Maximum Tension

TOP CHORD 1-2=-170/21, 2-3=-170/21
BOT CHORD 1-3=-10/127

NOTES

- Unbalanced roof live loads have been considered for this design.
- Wind: ASCE 7-10; Vult=115mph (3-second gust) Vasd=91mph; TC DL=6.0psf; BCDL=6.0psf; h=30ft; Cat. II; Exp B; Enclosed; MWFRS (envelope) exterior zone and C-C Exterior (2) zone; cantilever left and right exposed; end vertical left and right exposed; C-C for members and forces & MWFRS for reactions shown; Lumber DOL=1.60 plate grip DOL=1.60
- Truss designed for wind loads in the plane of the truss only. For studs exposed to wind (normal to the face), see Standard Industry Gable End Details as applicable, or consult qualified building designer as per ANSI/TPI 1.
- Gable requires continuous bottom chord bearing.
- Gable studs spaced at 2-0-0 oc.
- This truss has been designed for a 10.0 psf bottom chord live load nonconcurrent with any other live loads.
- * This truss has been designed for a live load of 20.0psf on the bottom chord in all areas where a rectangle 3-06-00 tall by 1-00-00 wide will fit between the bottom chord and any other members.

- Provide mechanical connection (by others) of truss to bearing plate capable of withstanding 2 lb uplift at joint 1 and 2 lb uplift at joint 3.
- This truss is designed in accordance with the 2015 International Residential Code sections R502.11.1 and R802.10.2 and referenced standard ANSI/TPI 1.

LOAD CASE(S) Standard

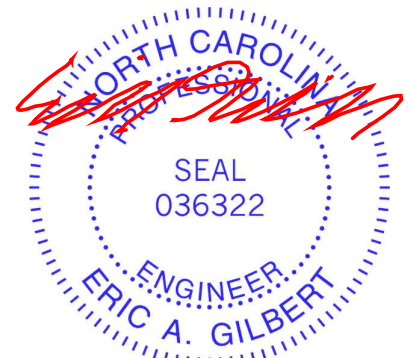

January 17, 2023

WARNING - Verify design parameters and READ NOTES ON THIS AND INCLUDED MITEK REFERENCE PAGE MII-7473 rev. 5/19/2020 BEFORE USE.

Design valid for use only with MiTek® connectors. This design is based only upon parameters shown, and is for an individual building component, not a truss system. Before use, the building designer must verify the applicability of design parameters and properly incorporate this design into the overall building design. Bracing indicated is to prevent buckling of individual truss web and/or chord members only. Additional temporary and permanent bracing is always required for stability and to prevent collapse with possible personal injury and property damage. For general guidance regarding the fabrication, storage, delivery, erection and bracing of trusses and truss systems, see **ANSI/TPI1 Quality Criteria, DSB-89 and BCSI Building Component Safety Information** available from Truss Plate Institute, 2670 Crain Highway, Suite 203 Waldorf, MD 20601

ENGINEERING BY
TRENCO
A MiTek Affiliate

818 Soundside Road
Edenton, NC 27932

Job 36029A	Truss V22	Truss Type Valley	Qty 1	Ply 1	57 SERENITY Job Reference (optional)	156132001
---------------	--------------	----------------------	----------	----------	---	-----------

84 Components (Dunn), Dunn, NC - 28334,

Run: 8.63 S Nov 19 2022 Print: 8.630 S Nov 19 2022 MiTek Industries, Inc. Fri Jan 13 10:17:18
ID:??TEpGWXYMWfMbcIDhZony6LBg-RfC?PsB70Hq3NSgPqnL8w3uITXbGKwRCDoi7J4zJC?f

Page: 1

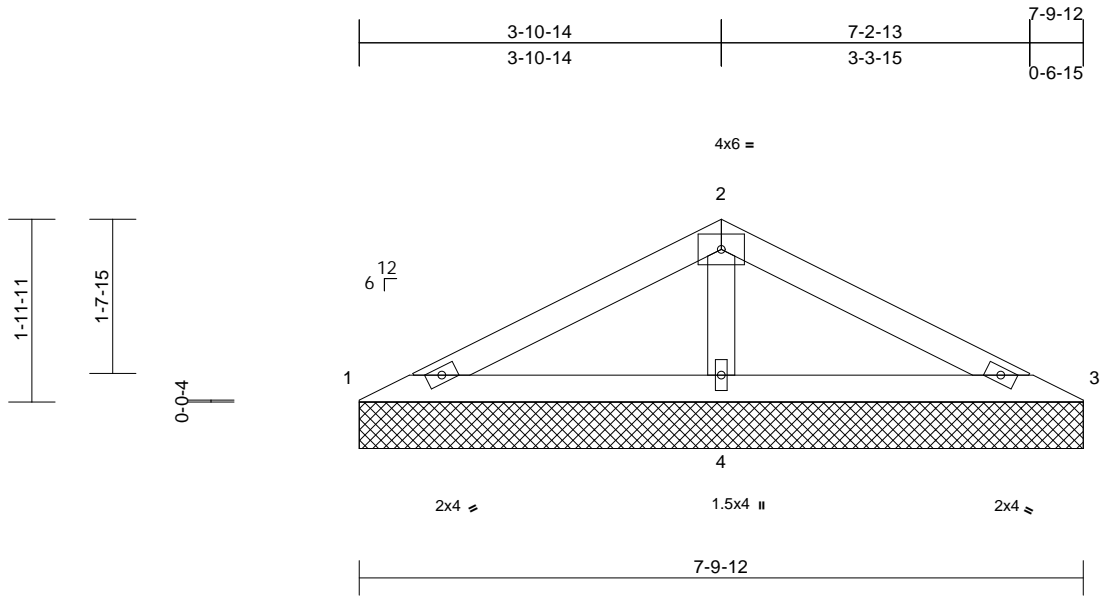

Scale = 1:24.9

Loading	(psf)	Spacing	2-0-0	CSI	DEFL	in	(loc)	l/defl	L/d	PLATES	GRIP	
TCLL (roof)	20.0	Plate Grip DOL	1.15	TC	0.29	Vert(LL)	n/a	-	n/a	999	MT20	244/190
TCDL	10.0	Lumber DOL	1.15	BC	0.19	Vert(TL)	n/a	-	n/a	999		
BCLL	0.0*	Rep Stress Incr	YES	WB	0.07	Horiz(TL)	0.00	4	n/a	n/a		
BCDL	10.0	Code	IRC2015/TPI2014	Matrix-MP							Weight: 25 lb	FT = 20%

LUMBER

TOP CHORD 2x4 SP No.3
BOT CHORD 2x4 SP No.2
OTHERS 2x4 SP No.3

BRACING

TOP CHORD Structural wood sheathing directly applied or 7-9-12 oc purlins.
BOT CHORD Rigid ceiling directly applied or 6-0-0 oc bracing.

REACTIONS

(size) 1=7-9-12, 3=7-9-12, 4=7-9-12
Max Horiz 1=-24 (LC 13)
Max Uplift 1=-5 (LC 12), 3=-10 (LC 13), 4=-8 (LC 12)
Max Grav 1=80 (LC 23), 3=80 (LC 24), 4=517 (LC 1)

FORCES

(lb) - Maximum Compression/Maximum Tension

TOP CHORD 1-2=-86/246, 2-3=-86/246
BOT CHORD 1-4=-195/95, 3-4=-195/95
WEBS 2-4=-354/117

NOTES

- Unbalanced roof live loads have been considered for this design.
- Wind: ASCE 7-10; Vult=115mph (3-second gust) Vasd=91mph; TC DL=6.0psf; BC DL=6.0psf; h=30ft; Cat. II; Exp B; Enclosed; MWFRS (envelope) exterior zone and C-C Exterior (2) zone; cantilever left and right exposed; end vertical left and right exposed; C-C for members and forces & MWFRS for reactions shown; Lumber DOL=1.60 plate grip DOL=1.60
- Truss designed for wind loads in the plane of the truss only. For studs exposed to wind (normal to the face), see Standard Industry Gable End Details as applicable, or consult qualified building designer as per ANSI/TPI 1.
- Gable requires continuous bottom chord bearing.
- Gable studs spaced at 2-0-0 oc.
- This truss has been designed for a 10.0 psf bottom chord live load nonconcurrent with any other live loads.

- * This truss has been designed for a live load of 20.0psf on the bottom chord in all areas where a rectangle 3-06-00 tall by 1-00-00 wide will fit between the bottom chord and any other members.
- Provide mechanical connection (by others) of truss to bearing plate capable of withstanding 5 lb uplift at joint 1, 10 lb uplift at joint 3 and 8 lb uplift at joint 4.
- This truss is designed in accordance with the 2015 International Residential Code sections R502.11.1 and R802.10.2 and referenced standard ANSI/TPI 1.

LOAD CASE(S) Standard

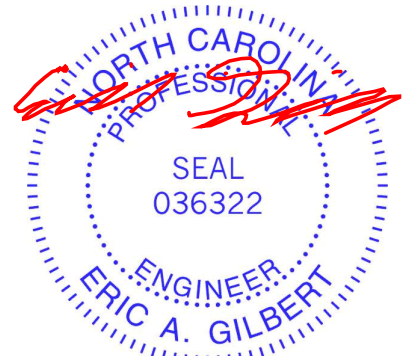

January 17, 2023

WARNING - Verify design parameters and READ NOTES ON THIS AND INCLUDED MITEK REFERENCE PAGE MII-7473 rev. 5/19/2020 BEFORE USE.

Design valid for use only with MiTek® connectors. This design is based only upon parameters shown, and is for an individual building component, not a truss system. Before use, the building designer must verify the applicability of design parameters and properly incorporate this design into the overall building design. Bracing indicated is to prevent buckling of individual truss web and/or chord members only. Additional temporary and permanent bracing is always required for stability and to prevent collapse with possible personal injury and property damage. For general guidance regarding the fabrication, storage, delivery, erection and bracing of trusses and truss systems, see

ANSI/TPI1 Quality Criteria, DSB-89 and BCSI Building Component

Safety Information available from Truss Plate Institute, 2670 Crain Highway, Suite 203 Waldorf, MD 20601



818 Soundside Road
Edenton, NC 27932

Symbols

PLATE LOCATION AND ORIENTATION

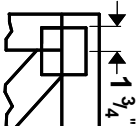

Center plate on joint unless x, y offsets are indicated. Dimensions are in ft-in-sixteenths. Apply plates to both sides of truss and fully embed teeth.

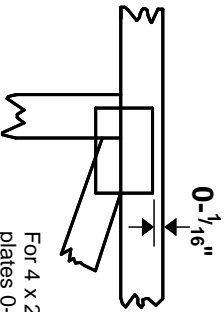

For 4 x 2 orientation, locate plates 0- 1/16" from outside edge of truss.



This symbol indicates the required direction of slots in connector plates.

* Plate location details available in **MITek 20/20 software** or upon request.

PLATE SIZE

4 X 4

The first dimension is the plate width measured perpendicular to slots. Second dimension is the length parallel to slots.

LATERAL BRACING LOCATION



Indicated by symbol shown and/or by text in the bracing section of the output. Use T or I bracing if indicated.

BEARING

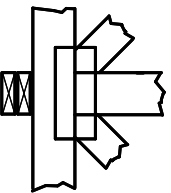

Indicates location where bearings (supports) occur. Icons vary but reaction section indicates joint number where bearings occur. Min size shown is for crushing only.

Industry Standards:

ANSI/TFP 1: National Design Specification for Metal Plate Connected Wood Truss Construction.
DSB-89: Design Standard for Bracing, Building Component Safety Information, Guide to Good Practice for Handling, Installing & Bracing of Metal Plate
BCSI: Connected Wood Trusses.

Numbering System

6-4-8
dimensions shown in ft-in-sixteenths
(Drawings not to scale)

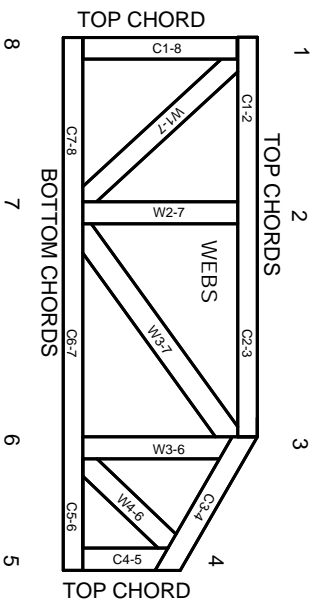

JOINTS ARE GENERALLY NUMBERED/LETTERED CLOCKWISE AROUND THE TRUSS STARTING AT THE JOINT FARTHEST TO THE LEFT.

CHORDS AND WEBS ARE IDENTIFIED BY END JOINT NUMBERS/LETTERS.

PRODUCT CODE APPROVALS

ICC-ES Reports:

ESR-1311, ESR-1352, ESR1988
ER-3907, ESR-2362, ESR-1397, ESR-3282

Trusses are designed for wind loads in the plane of the truss unless otherwise shown.

Lumber design values are in accordance with ANSI/TFP 1 section 6.3 These truss designs rely on lumber values established by others.

© 2012 MITteK® All Rights Reserved



MITek Engineering Reference Sheet: MII-7473 rev. 5/19/2020



General Safety Notes

Failure to Follow Could Cause Property Damage or Personal Injury

1. Additional stability bracing for truss system, e.g. diagonal or X-bracing, is always required. See BCSI.
2. Truss bracing must be designed by an engineer. For wide truss spacing, individual lateral braces themselves may require bracing, or alternative Tor I bracing should be considered.
3. Never exceed the design loading shown and never stack materials on inadequately braced trusses.
4. Provide copies of this truss design to the building designer, erection supervisor, property owner and all other interested parties.
5. Cut members to bear tightly against each other.
6. Place plates on each face of truss at each joint and embed fully. Knots and wane at joint locations are regulated by ANSI/TFP 1.
7. Design assumes trusses will be suitably protected from the environment in accord with ANSI/TFP 1.
8. Unless otherwise noted, moisture content of lumber shall not exceed 19% at time of fabrication.
9. Unless expressly noted, this design is not applicable for use with fire retardant, preservative treated, or green lumber.
10. Camber is a non-structural consideration and is the responsibility of truss fabricator. General practice is to camber for dead load deflection.
11. Plate type, size, orientation and location dimensions indicated are minimum plating requirements.
12. Lumber used shall be of the species and size, and in all respects, equal to or better than that specified.
13. Top chords must be sheathed or purlins provided at spacing indicated on design.
14. Bottom chords require lateral bracing at 10 ft. spacing, or less, if no ceiling is installed, unless otherwise noted.
15. Connections not shown are the responsibility of others.
16. Do not cut or alter truss member or plate without prior approval of an engineer.
17. Install and load vertically unless indicated otherwise.
18. Use of green or treated lumber may pose unacceptable environmental, health or performance risks. Consult with project engineer before use.
19. Review all portions of this design (front, back, words and pictures) before use. Rewriting pictures alone is not sufficient.
20. Design assumes manufacture in accordance with ANSI/TFP 1 Quality Criteria.
21. The design does not take into account any dynamic or other loads other than those expressly stated.