



Square Footage

Living Areas	
First Floor	906 SF
Second Floor	1138 SF
	2044 SF
Unfinished Areas	
Front Covered Porch	115 SF
Garage	458 SF
Screened-in Patio	144 SF
	718 SF

Redraws

Plan Review: 02/14/2023

- Added 6040 triple slider window above kitchen sink. (2.01F, 2.01S, 4.01, 6.03)
- Moved screened-in porch door closer to house. (2.01F, 2.01S, 4.01, 6.03)

Plan Review: XX/XX/XX

Xxxx

Fenestration Calculations:

Total Wall Square Footage: 3034.80

Total Window Square Footage: 310.00

Total Fenestration %: 10.21%

Division: RALEIGH

Building Code: 2018 North Carolina Residential Building Code

Index to the Drawings

Sheet No.	Sheet Name
0C.1	Cover Sheet
0N.1	General Notes
0P.1	Plot Plan
1.01S	Foundation Plan (Slab)
2.01F	First Floor Framing Plan
2.01S	First Floor Structural Plan
2.02F	Second Floor Framing Plan
2.02S	Second Floor Structural Plan
2.04	Roof Plan
3.02	Second Floor Subfloor Plan
4.01	First Floor Mechanical Plan
4.02	Second Floor Mechanical Plan
5.01	Building Section
6.01	Front Elevation
6.02	Garage Side Elevation
6.03	Rear Elevation
6.04	Side Elevation
7.01	House Specific Details
SD-1.0	Structural Notes
SD-2.0	Structural Notes

Space for Architect Seal

RESIDENCE FOR:
MARKET HOME
31 CONTENTMANT LANE
SERENITY

Job Number: **STY5-0064-00** Drawing Date: **02/06/2023** Coord Name: **GREG P.** Coord Phone: **859-578-4355**

House Name: _____ Drawing Scale: 1/8" = 1'0" Contract Drawn By: **MSA**

Series: **CLASSIC**

Plan No.: _____

Born on Date: 11/11/22 CDs Drawn By: CLM



7701 Six Forks Road, Suite 132, Raleigh, NC 27615
Phone: [919] 844-9288

Sheet Information

0C.1

Cover Sheet
Elevation "B"

Architecture Plan Review: No Comments See Comments

Items drawn on any drawings and not written in the contract selections **WILL NOT** be included in the site specific drawings.

Customer Request:	Design Solution:	Reason For Modification:	Comments:
1. XXX	1. XXX	1. XXX	1. XXX
2. XXX	2. XXX	2. XXX	2. XXX
3. XXX	3. XXX	3. XXX	3. XXX
4. XXX	4. XXX	4. XXX	4. XXX

Customer Plan Review Signature

I understand that my new Drees home will be built in general conformance to the plans, specifications, selections and the Purchase Agreement, all of which I have reviewed and approved. This set of plans may not reflect the elevations or options for my house. Drees draws the standard plans complete with the most common options. The subcontractor's sets will show only the options I selected in my selection sheets. I have reviewed the plot plan for my house and understand that there may be some field adjustments as to the exact location of the house on the lot. I further understand that my home will not be built exactly like any other Drees home or Model and that some minor variations from my plans and specifications may occur since every home that is built has it's own set of unique construction problems that must be dealt with as the home is being built.

Customer: _____ Date: _____

Customer: _____ Date: _____

GENERAL NOTES - RALEIGH

FOUNDATION NOTES

CRAWL SPACES:

- SLOPE CONCRETE SLAB 4" MINIMUM TOWARDS GARAGE DOOR
- EXTERIOR FLATWORK/GARAGES SHALL HAVE A MINIMUM CONCRETE STRENGTH OF 4,500 PSI
- FOOTINGS TO A MINIMUM CONCRETE STRENGTH OF 2500 PSI, UNLESS OTHERWISE NOTED
- ASSUMED ALLOWABLE SOIL BEARING PRESSURE: 2,000 p.s.f.
- WATERPROOF FOUNDATION WITH BITUMINOUS SPRAY.
- WALL TIES EMBEDDED IN THE HORIZONTAL MORTAR JOINT SHALL BE 16" ON CENTER. TIES IN ALTERNATE COURSES SHALL BE STAGGERED. THE MAXIMUM VERTICAL DISTANCE BETWEEN TIES SHALL NOT EXCEED 16" AND THE MAXIMUM HORIZONTAL DISTANCE SHALL NOT EXCEED 16" ADDITIONAL TIES SHALL BE PROVIDED AT ALL OPENINGS, AND WITHIN 12" OF THE OPENING.
- CORE FILL ENTIRE BLOCK WALL WHEN THE WALL IS 4'-0" TALL OR HIGHER. INSTALL #4 REBAR IN EACH HOLLOW AREA OF EACH BLOCK FROM FOOTING TO TOP OF WALL, ON THE ENTIRE WALL PRIOR TO CORE FILLING IT.
- TOP COURSE OF BLOCK ON ALL WALLS WILL BE FILLED SOLID WITH MORTAR PLACING THE FOUNDATION STRAPS OR BOLTS IN THE MORTAR 6'-0" ON CENTER, AND 12" FROM EACH CORNER.
- 12"x16" PIERS: HOLLOW MASONRY UP TO 48" HIGH, SOLID MASONRY UP TO 9'0" HIGH
- 16"x16" PIERS: HOLLOW MASONRY UP TO 64" HIGH, SOLID MASONRY UP TO 12'0" HIGH
- BLOCK PIERS SHOULD BE PLACED DIRECTLY ON CONCRETE FOOTINGS PER PLAN. THEY SHOULD BE PLUMBED AND SQUARE WITHIN 1/4".
- SILL PLATES TO BE A MINIMUM OF 2x4 NOMINAL LUMBER.

BASEMENTS:

- SLOPE CONCRETE SLAB 4" MINIMUM TOWARDS GARAGE DOOR
- EXTERIOR FLATWORK/GARAGES SHALL HAVE A MINIMUM CONCRETE STRENGTH OF 4,500 PSI
- FOOTINGS TO A MINIMUM CONCRETE STRENGTH OF 2500 PSI, UNLESS OTHERWISE NOTED- ALL FOUNDATION WALLS TO BE CAST IN PLACE CONCRETE 3000 PSI MIN. UNLESS OTHERWISE NOTED.
- BASEMENT WINDOW LOCATIONS MAY VARY FROM DRAWING DUE TO LOT CONDITIONS.
- BACKFILL ADJACENT TO FOUNDATION WALLS SHALL NOT BE PLACED UNTIL THE WALL HAS SUFFICIENT STRENGTH AND HAS BEEN ANCHORED TO THE FLOOR OR HAS BEEN SUFFICIENTLY BRACED TO PREVENT DAMAGE BY THE BACKFILL.
- ASSUMED ALLOWABLE SOIL BEARING PRESSURE: 2,000 p.s.f.
- WATERPROOF FOUNDATION WITH BITUMINOUS SPRAY.
- VERTICAL CONTROL JOINTS IN BASEMENT FOUNDATION WALLS - STANDARD LOCATION GUIDELINES:
 - 1) PLACE A CONTROL JOINT IN ALL UNBRACED WALLS OVER 30' IN LENGTH. (NOTE: "T" WALLS AND CORNERS COUNT AS A BRACE).
 - 2) WINDOWS THAT ARE LARGER THAN THE STANDARD BASEMENT WINDOW REQUIRE A CONTROL JOINT.
 - 3) CONTROL JOINTS ARE NOT REQUIRED AT EVERY WINDOW THAT IS STANDARD SIZE.
 - 4) IF THERE IS A STANDARD WINDOW LOCATED IN A WALL SEGMENT THAT REQUIRES A CONTROL JOINT, THEN THE CONTROL JOINT SHOULD BE PLACED ON THE SIDE OF THE WINDOW THAT IS ADJACENT TO THE LONG SIDE OF THE WALL. IF THERE IS MORE THAN ONE WINDOW IN A WALL THEN ONLY ONE WINDOW SHOULD HAVE A CONTROL JOINT.
 - 5) DOORS DO NOT GET CONTROL JOINTS.
 - 6) CONTROL JOINTS SHOULD NOT BE LOCATED WITHIN 3' OF A BEAM POCKET.
 - 7) CONTROL JOINTS ARE REQUIRED AT THE FIRST AND LAST STEP DOWN AT STEPPED BASEMENT FOUNDATION WALLS.
- INTERIOR FLATWORK SHALL HAVE A MINIMUM CONCRETE STRENGTH OF 3,000 PSI.
- ALL VERTICAL STEEL AND ALL STEEL IN STRUCTURAL SLABS TO BE GRADE 60. ALL HORIZONTAL STEEL IN FOUNDATION WALLS AND FOOTERS TO BE GRADE 40 STEEL.

FRAMING NOTES

DESIGN LOADS:

FLOORS:	40 psf LIVE LOAD + 10 psf DEAD LOAD = 50 psf	GARAGE FLOOR: 50 psf LIVE LOAD	SEISMIC: "A" & "B"
ROOF:	18 psf LIVE LOAD + 17psf DEAD LOAD = 35 psf	WIND SPEED: 120 MPH	
DESIGN DEFLECTION LIMITS (BASED ON LIVE LOAD, EXCEPT MASONRY):			
	RAFTERS GREATER THAN 3:12	L/180	CEILING
	MASONRY VENEER	L/600	
	NOMINAL LUMBER FLOORS:	L/360	
	MANUFACTURED WOOD FLOORS:	DESIGNED TO MINIMUM PRO RATING OF 35 (OR EQUIVALENT), NO MORE THAN 8 POINT DIFFERENCE BETWEEN ADJACENT SPANS.	
		L/480 FOR SPANS UP TO 16'-0" AND NO GREATER THAN 1/2" DEFLECTION	
		L/600 FOR SPANS OVER 16'-0" IF SIMPLE SPAN AND NO GREATER THAN 1/2" DEFLECTION	
		L/840 FOR SPANS OVER 16'-0" IF CONTINUOUS SPAN. AND NO GREATER THAN 1/2" DEFLECTION	

- JOIST SPACING: 19.2" o.c. MAXIMUM SPACING
- DOUBLE EVERY OTHER FLOOR JOIST UNDER KITCHEN ISLANDS
- INSTALL UNCOUPLING MEMBRANE IN TILE FLOOR AREAS IF 19.2" o.c. FLOOR JOIST SPACING
- GLUE AND MECHANICALLY FASTEN [SCREWS] WOOD FLOOR IF 19.2" o.c. FLOOR JOIST SPACING
- MANUFACTURED WOOD PRODUCTS (INCLUDING, BUT NOT LIMITED TO, STRUCTURAL WOOD BEAMS AND I-JOISTS) SHALL BE FABRICATED, HANDLED, AND INSTALLED IN ACCORDANCE WITH THE MANUFACTURER'S INSTRUCTIONS.
- JOISTS ARE NOT TO BE PLACED DIRECTLY OVER INTERIOR PARALLEL WALLS. (TO PREVENT UNEVEN FLOOR DEFLECTION FROM OCCURRING)
- ALL WOOD BEAMS/HEADERS: 2x6's TO BE SPF STUD GRADE OR BETTER/ 2x8 OR LARGER TO BE SYP #2 [PER NDS 2012] OR BETTER, U.O.N.
- ALL HEADERS SHALL BE SUPPORTED BY (1) 2x JACK STUD AND (1) 2x KING STUD MINIMUM. THE NUMBER OF STUDS SPECIFIED AT A SUPPORT INDICATES THE NUMBER OF JACKS REQUIRED, U.N.O. AT FLUSH OR DROPPED BEAMS, THE NUMBER OF STUDS SPECIFIED INDICATES THE TOTAL NUMBER OF STUDS REQUIRED TO SUPPORT THE BEAM.
- EXTERIOR WALLS TO BE 2x4 SPF STUD GRADE AT 16" o.c. UNLESS OTHERWISE NOTED (10'4-1/2" MAXIMUM WALL HEIGHT)
- ALL INTERIOR BEARING WALLS AND WALLS AT BASEMENT & FIRST FLOOR STAIRWELLS, KITCHEN, BATH, & GARAGE TO BE 2x4 SPF STUD GRADE @ 16" o.c.;
- ALL OTHER NON-BEARING INTERIOR WALLS TO BE 2x4 SPF STUD GRADE @ 24" o.c. U.O.N.
- ALL WALLS TO BE 3 1/2" UNLESS OTHERWISE NOTED.
- PROVIDE SOLID BEARING TO FOUNDATION OR BEAM BELOW FOR ALL BEAMS, HEADERS & GIRDER TRUSSES. PROVIDE BLOCKING BETWEEN JOISTS AS REQUIRED.
- SEE SELECTION SHEET FOR SIZE AND STYLE OF FIREPLACE. SEE FIREPLACE ELEVATION DETAIL FOR ADDITIONAL FRAMING REQUIREMENTS, IF ANY.
- CHECK SELECTION SHEETS FOR FLOOR COVERING AT TOP AND BOTTOM OF STAIR RISERS AND ADJUST RISERS AS REQ'D.
- PROVIDE BLOCKING AT ALL HANDRAIL TERMINATION AND BRACKET LOCATIONS.
- 20-MINUTE FIRE RATED DOOR BETWEEN GARAGE AND LIVING AREA.
- EXTERIOR WALL TO BE 2x4 SPF STUD G AT 16" o.c. UNLESS OTHERWISE NOTED (10'-0" MAXIMUM UNBRACED WALL HEIGHT).
- ALL EXTERIOR WALLS AND INTERIOR BEARING WALLS, FRAMED HIGHER THAN THE STANDARD PLATE HEIGHT, SHALL BE FRAMED WITH CONTINUOUS FULL HEIGHT STUDS TO THE HIGHEST CEILING (I.E. NO INTERMEDIATE BREAKS) TO PREVENT LATERAL HINGE CONDITIONS.
- IN THE GARAGE, PROVIDE 1/2" GYP. BOARD AT ALL WALLS COMMON TO LIVING SPACE AND ALL STRUCTURAL MEMBERS SUPPORTING FLOOR/CEILING ASSEMBLY. GARAGE CEILING TO BE 1/2" SAG RESISTANT GYP. BOARD WHEN THERE ARE NO HABITABLE SPACES ABOVE, OR 5/8" TYPE X GYP. BOARD WHEN HABITABLE SPACES ARE ABOVE.
- ALL EMERGENCY ESCAPE & RESCUE OPENINGS TO BE A MAXIMUM OF 44" OFF OF FINISHED FLOOR AND HAVE MINIMUM OPENING DIMENSIONS OF 24" IN HEIGHT, 20" IN WIDTH, & HAVE A MINIMUM OPENING AREA OF 5.7 S.F.
- ALL DOORS TO BE 6'-8" TALL UNLESS OTHERWISE NOTED.
- ALL GLASS IN INTERIOR AND EXTERIOR DOORS TO BE TEMPERED (INCLUDING SIDELITES AND TRANSOMS)
- ALL LUMBER CONTACTING CONCRETE TO BE PRESSURE TREATED.
- ALL FASTENERS, HANGERS, AND OTHER CONNECTORS TO BE USED WITH PRESSURE TREATED WOOD ARE TO HAVE ZMAX COATING (OR EQUIVALENT) HOT-DIPPED GALVANIZED OR STAINLESS STEEL.
- AT STAIR HANDRAIL, ON ONE SIDE ONLY, SHALL BE CONTINUOUS FOR THE ENTIRE LENGTH OF THE STAIRWAY, AND ENDS SHALL BE RETURNED TO A WALL OR POST. THE HANDRAIL MAY BE INTERRUPTED AT A NEWEL POST AT A TURN.
- ALL HANDRAIL GRIP PORTIONS SHALL NOT EXCEED 2-1/4" IN CROSS SECTIONAL DIMENSION.
- HANDRAILS SHALL BE INSTALLED ON ALL STAIRS WITH 2 OR MORE RISERS, HANDRAIL HEIGHTS SHALL BE A MINIMUM OF 34" AND A MAXIMUM OF 38".
- ALL STAIRS TO BE CONSTRUCTED SO AS NOT TO ALLOW A 4" SPHERE TO PASS THROUGH THE RISER.
- GUARDRAILS MUST BE A MINIMUM OF 36" HIGH. GUARDRAILS AT THE OPEN SIDES OF STAIRS MUST BE A MINIMUM OF 34" HIGH MEASURED VERTICALLY FROM THE NOSING AT THE TREADS. THE HORIZONTAL SPACING OF THE VERTICAL BALUSTERS SHALL BE 4" O.C.
- GUARDRAIL DESIGN TO RESIST A MINIMUM OF 200 LBS LATERAL FORCE

MECHANICAL/ELECTRICAL NOTES

- ANY GAS APPLIANCES MUST BE INSTALLED PER MANUFACTURER'S SPECIFICATIONS.
- HOLD THE CENTERLINE OF ALL EXTERIOR LIGHT FIXTURES AT 5'-8" OFF BOTTOM OF DOOR OPENING.
- ALL KITCHEN CABINET DIMENSIONS ARE CABINET TO CABINET.
- CABINET STYLES MAY VARY FROM INTERIOR ELEVATIONS DEPENDING ON STYLE, MANUFACTURER, ETC. FOR CABINET DETAILS SEE SHOP DRAWINGS.
- CABINET SIZES MAY VARY WITH FULL-OVERLAY CABINETS.
- GROUND FAULT INTERRUPTER (GFCI) OUTLETS TO BE INSTALLED PER NEC 2017, SECT. 210.8
- PROVIDE HOSE BIBS PER DIVISION SPEC. SHEET. EXACT LOCATION TO BE FIELD DETERMINED UNLESS OTHERWISE NOTED ON THE PLANS.
- MIN. 50 C.F.M. FOR ALL EXHAUST FANS IN BATHROOMS

INSULATION DETAILS

EXTERIOR STUD WALL CAVITY:	(2x4)	R-15
(2x6)	R-19	
FLOOR JOIST CAVITY AT STANDARD PERIMETER:	R-19	
FLOOR JOIST CAVITY AT CANTILEVER:	R-19	
OVER GARAGE: (OVER HORIZONTAL SPACE)	R-38 BLOWN	
(SLOPED AND VERTICAL SPACE)	R-38 BATT	

ELEVATION NOTES

- WINDOW STYLE AND MULLIONS MAY VARY FROM ELEVATION DEPENDING UPON MANUFACTURER, STYLE, PATTERN, TYPE, ETC.
- USE SECONDARY HEAT BARRIER ON ALL DIRECT VENT FIREPLACES 7" OR LESS ABOVE A WALKWAY.
- GRADE AWAY FROM FOUNDATION WALLS SHALL FALL A MINIMUM OF 6" WITHIN THE FIRST 10'.
- PROVIDE TYVEK OR EQUIVALENT HOUSE WRAP BEHIND BRICK AND STONE VENEER OVER WOOD SHEATHING.
- PROVIDE BRICK WEEP HOLES AT 24" O.C. WITH BRICK VENEER AND MORTAR NET BEHIND AND THROUGH WEEP HOLES.
- PROVIDE FLASHING AND WEEP HOLES ABOVE ALL BRICK ANGLE IRONS, BELOW ALL BRICK SILLS AND ABOVE SILL PLATE SEALERS.
- EXTERIOR STEPS TO HAVE A MAXIMUM 8" RISER. WHEN VERTICAL RISE EXCEEDS 30" OR FOUR OR MORE CONTINUOUS RISERS, A HANDRAIL IS REQUIRED.

ROOF PLAN NOTES

- ALL OVERHANGS TO HAVE (2) SOFFIT VENTS PER EACH 8' SOFFIT SECTION.
- PROVIDE BAFFLES AT EXTERIOR TRUSS BEARING FOR VENTILATION.
- PROVIDE 15# FELT PAPER UNDER SHINGLES.

Space for Architect Seal

RESIDENCE FOR: MARKET HOME 31 CONTENTMANT LANE SERENITY

Job Number: STY5-0064-00	Drawing Date: 02/06/2023	Coord Name: GREG P.	Coord Phone: 859-578-4355
------------------------------------	------------------------------------	-------------------------------	-------------------------------------

House Name:	Drawing Scale: 1/8" = 1'0"	Contract Drawn By: MSA
-------------	----------------------------	----------------------------------

the GRACE	Series: CLASSIC
------------------	---------------------------

Born on Date:	11/11/22	CDs Drawn By:	CLM	Plan No.:	-
---------------	----------	---------------	-----	-----------	---

 <p>Copyright © 2022 (2022) The Drees Company. All Rights Reserved. 7701 Six Forks Road, Suite 132, Raleigh, NC 27615 Phone: (919) 844-9288</p>	Sheet Information	0N.1
		<p>General Notes Elevation "B"</p>

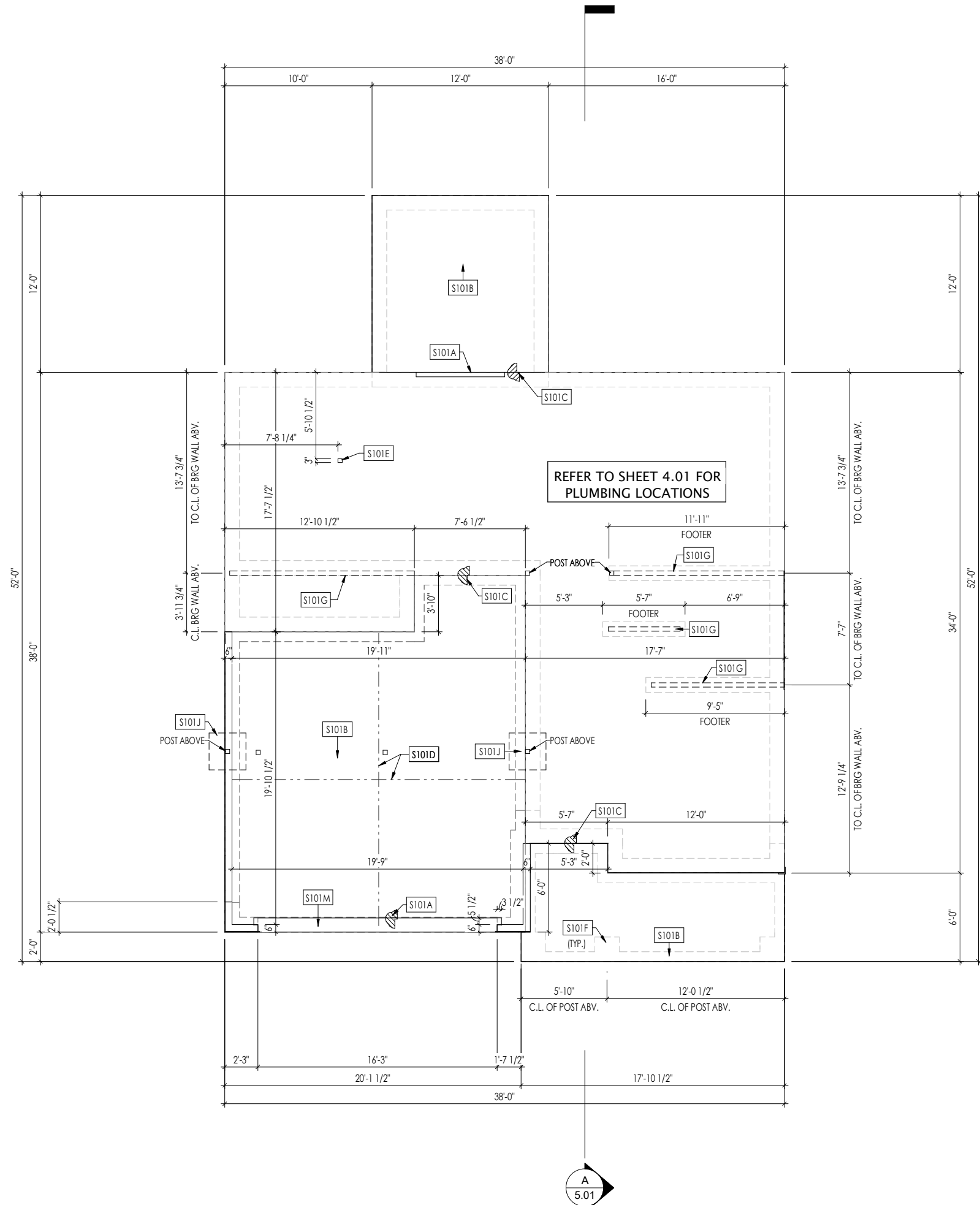

General Notes:

1. REFER TO SHEET ON.1 FOR GENERAL NOTES.

Key Notes:

S101A	3/4" WEATHER LIP (1-1/2" @ SLIDING GLASS DOOR)
S101B	SLOPE SLAB 1/8" PER FOOT
S101C	DROP SLAB 3-1/2"
S101D	SLAB CONTROL JOINT
S101E	PROVIDE CONDUIT FOR ELECTRIC TO KITCHEN ISLAND
S101F	PAD FOOTING UNDER PORCH COLUMN ABOVE - SEE DETAIL F/D1.3
S101G	8"x16" THICKENED PLAIN CONCRETE FOOTING UNDER BEARING WALL ABOVE
S101J	30"x30"x12" ENLARGED CONCRETE FOOTING UNDER POST ABOVE
S101M	CONTINUOUS FOOTING AND FOUNDATION; DROP TO BE FIELD DETERMINED

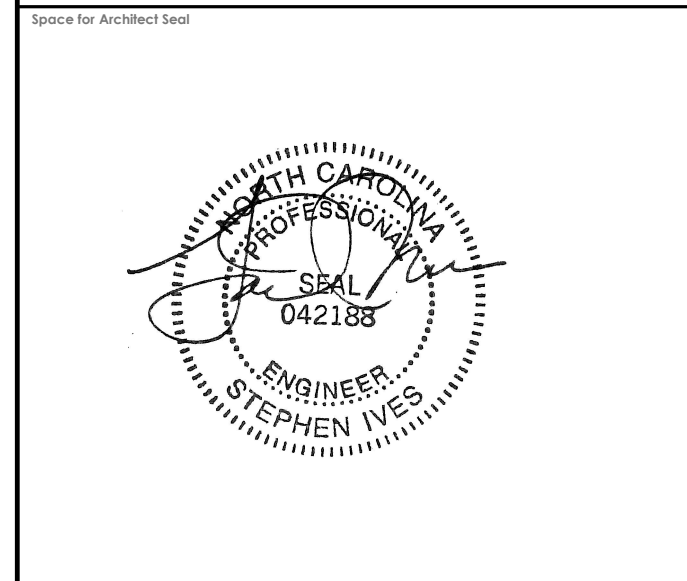

RESIDENCE FOR:
MARKET HOME
 31 CONTENTMANT LANE
 SERENITY

Job Number: STY5-0064-00	Drawing Date: 02/06/2023	Coord Name: GREG P.	Coord Phone: 859-578-4355
House Name: the GRACE		Drawing Scale: 1/8" = 1'0"	
		Contract Drawn By: MSA	
		Series: CLASSIC	
Born on Date: 11/11/22		CDs Drawn By: CLM	

1.01S
 Foundation Plan (Slab)
 Elevation "B"

Sheet Information

PROVIDE 8' TALL DOORS
THROUGHOUT FIRST FLOOR,
U.N.O.

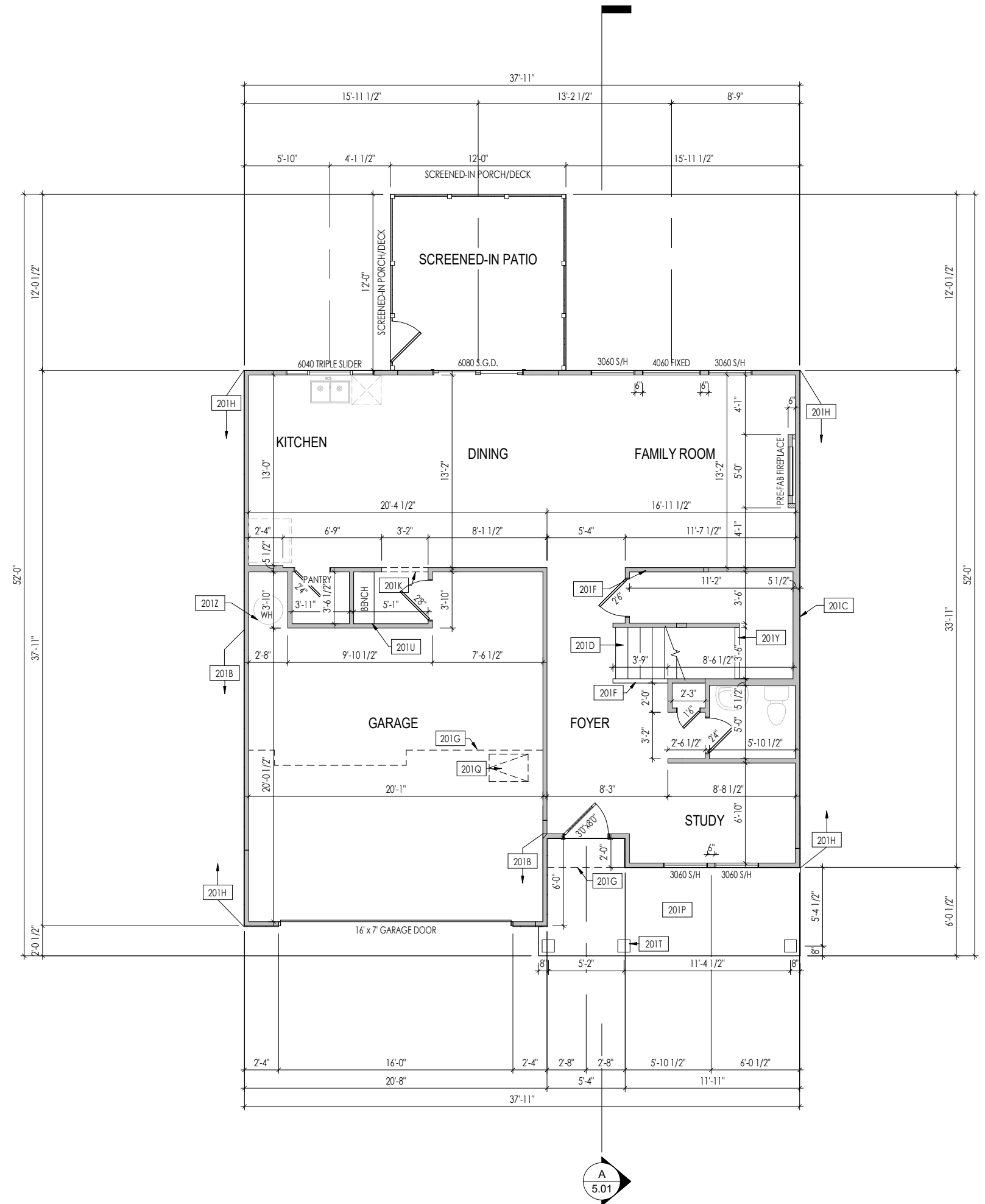

- General Notes:**
1. REFER TO SHEET 0N.1 FOR GENERAL NOTES.
 2. ALL FIRST FLOOR CEILINGS TO BE 10'-1" ABOVE SUBFLOOR UNLESS OTHERWISE NOTED.
 3. FRAME TOP OF ALL WINDOWS AT 1'-10" BELOW TOP OF PLATE UNLESS OTHERWISE NOTED.
 4. ALL DROPPED, INTERIOR HEADERS (FALSE AND BEARING) ARE DROPPED 1'-3" FROM CEILING.
 5. REFER TO SELECTION SHEETS FOR FLOORING MATERIAL PRIOR TO CONSTRUCTING STAIRS TO DETERMINE RISER HEIGHTS.
 6. REFER TO SHEET 2.01S FOR STRUCTURAL INFORMATION.
 7. ALL FIRST FLOOR EXTERIOR WALLS AND INTERIOR BEARING WALLS TO BE FRAMED AT 10'-1" HIGH WITH 2x4 STUDS @ 16" O.C.

- Key Notes:**
- 201B FRAME GARAGE WALLS AT 8'-8 1/2" WITH 2x4 STUDS AT 16" O.C. FROM TOP OF FOUNDATION WALL
 - 201C 2x6 BALLOON FRAMED WALL - SEE SHEET 2.01S FOR MORE INFO
 - 201D SEE DETAIL D/7.01 FOR STAIR FRAMING DETAILS
 - 201F SLOPE WALL EVEN WITH TOP OF STAIR STRINGER, RAILING ABOVE
 - 201G OUTLINE OF SECOND FLOOR ABOVE
 - 201H PROVIDE 1/2" FIRE RATED PLYWOOD THIS SIDE
 - 201K FRAME TOP OF OPENING AT HEIGHT SPECIFIED IN GENERAL NOTES ON THIS SHEET
 - 201P CARPENTER TO DROP ELECTRICAL WIRE THROUGH PORCH CEILING FOR LIGHTS
 - 201Q 22-1/2" x 32" ATTIC ACCESS
 - 201T SEE DETAIL E/7.01 FOR FRONT PORCH COLUMN FRAMING INFO
 - 201U BENCH - SEE DETAIL F/D2.2
 - 201Y WALL UNDER STAIR LANDING. HEIGHT TO BE FIELD DETERMINED
 - 201Z 18" HIGH WATER HEATER PLATFORM

Space for Architect Seal

**RESIDENCE FOR:
MARKET HOME
31 CONTENTMANT LANE
SERENITY**

Job Number: STY5-0064-00	Drawing Date: 02/06/2023	Coord Name: GREG P.	Coord Phone: 859-578-4355
House Name: the GRACE			Contract Drawn By: MSA
Born on Date: 11/11/22			CDs Drawn By: CLM
Drawing Scale: 1/8" = 1'-0"			Series: CLASSIC
Plan No.:			

<p>Drees HOMES SM</p> <p><small>Copyright © 2022 (2022) The Drees Company. All Rights Reserved. 7701 Six Forks Road, Suite 132, Raleigh, NC 27615 Phone: (919) 844-9288</small></p>	Sheet Information	2.01F
		First Floor Framing Plan Elevation "B"

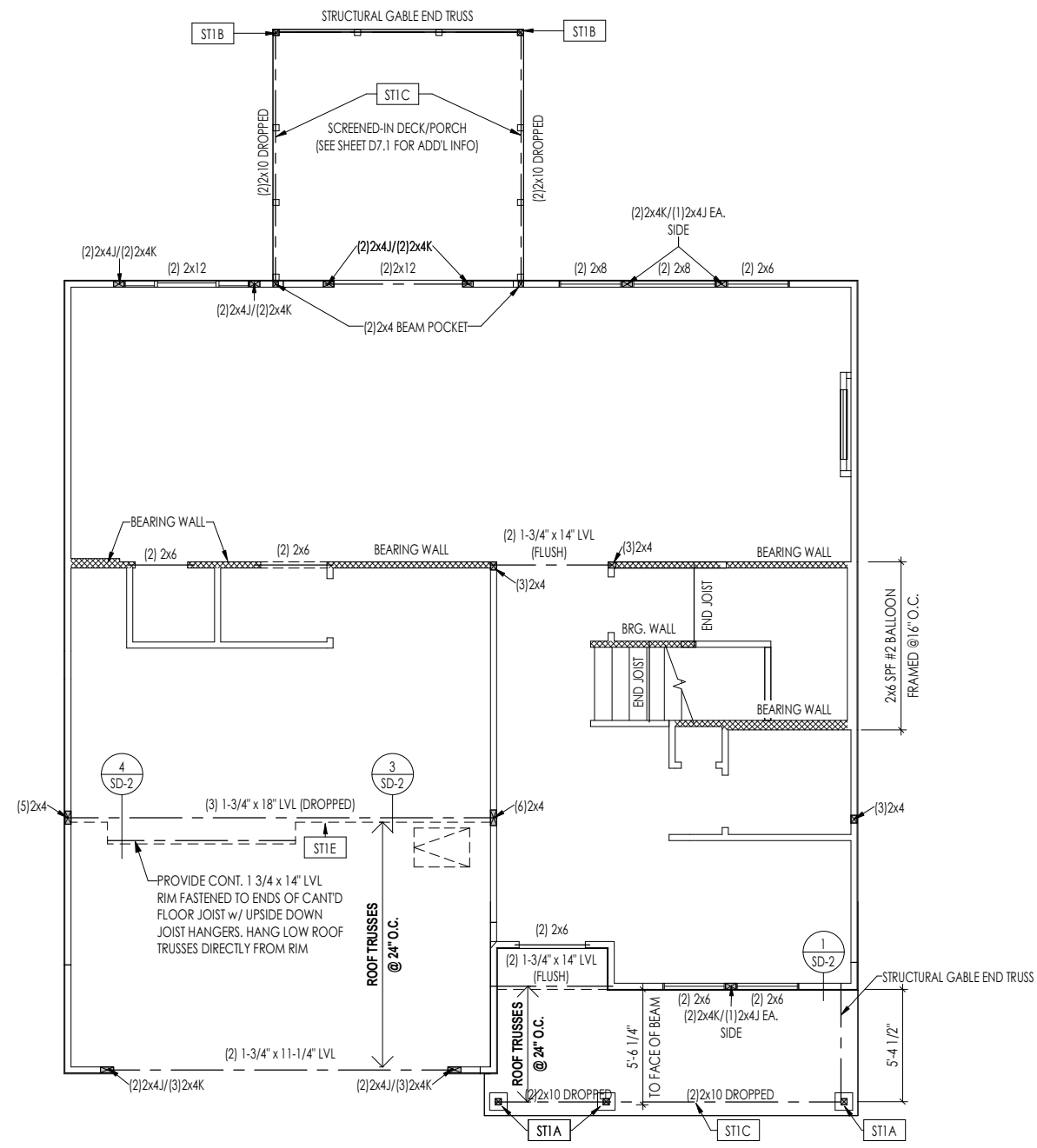

General Notes:

1. REFER TO SHEET ON.1 FOR GENERAL NOTES AND SD-1 FOR ENGINEERING NOTES.

Key Notes:

ST1A	4x4 P.T. WOOD POST WITH SIMPSON ABW44Z POST BASE AND SIMPSON BCS2-2/4 CAP
ST1B	4x4 P.T. POST W/ SIMPSON BCS2-2/4 CAP & BASE (PROVIDE ABW44Z BASE @ OPT. SOG FOUNDATION)
ST1C	FRAME TOP OF BEAM AT 9'-1" ABOVE FIRST FLOOR SUBFLOOR/SLAB
ST1E	OUTLINE OF SECOND FLOOR ABOVE

CONNECTION SPECIFICATIONS (TYP. U.N.O.)

NOTE: 10d NAIL = 3" x 0.131" GUN NAIL

JOIST TO SOLE PLATE	(3) 10d TOENAILS
SOLE PLATE TO JOIST/BLK'G.	10d NAILS @ 6" o.c.
STUD TO SOLE PLATE	(3) 10d TOENAILS
TOP OR SOLE PLATE TO STUD	(3) 10d NAILS
RIM TO TOP PLATE	10d TOENAILS @ 6" o.c.
BLK'G. BTWN. JOISTS TO TOP PL.	(3) 10d TOENAILS
RAFTER/TRUSS TO TOP PLATE	(3) 10d TOENAILS + (1) SIMPSON H2.5A
GAB. END TRUSS TO DBL. TOP PL.	10d TOENAILS @ 8" o.c.
R.T. w/ HEEL HT. 9 1/4" TO 12"	2x10 BLK EVERY 3RD BAY FASTENED TO DBL. TOP PLATE w/ 10d TOENAILS @ 6" O.C.
R.T. w/ HEEL HT. 12" TO 16"	2x12 BLK EVERY 3RD BAY FASTENED TO DBL. TOP PLATE w/ 10d TOENAILS @ 6" O.C.
R.T. w/ HEEL HT. UP TO 24"	LAP WALL SHTG. w/ DBL. TOP PL. & INSTALL ON TRUSS VERT. - FASTEN w/ 8d NAILS @ 6" O.C.
R.T. w/ HEEL HT. 24" TO 48"	LAP WALL SHTG. w/ DBL. TOP PL. & INSTALL ON TRUSS VERT. - FASTEN w/ 8d NAILS @ 6" O.C. PROVIDE 2x BLK @ EA. BAY AT TOP OF HEEL
DOUBLE STUD	10d NAILS @ 24" o.c.
DOUBLE TOP PLATE	10d NAILS @ 24" o.c.
DOUBLE TOP PLATE LAP SPLICE	(10) 10d NAILS IN LAPPED AREA
TOP PLATE LAP @ CORNERS & INTERSECTING WALLS	(2) 10d NAILS
WALL TO FOUNDATION	WALL SHTG. LAP w/ SILL PL. & FASTENED PER SHEAR WALL FASTENING SPEC.

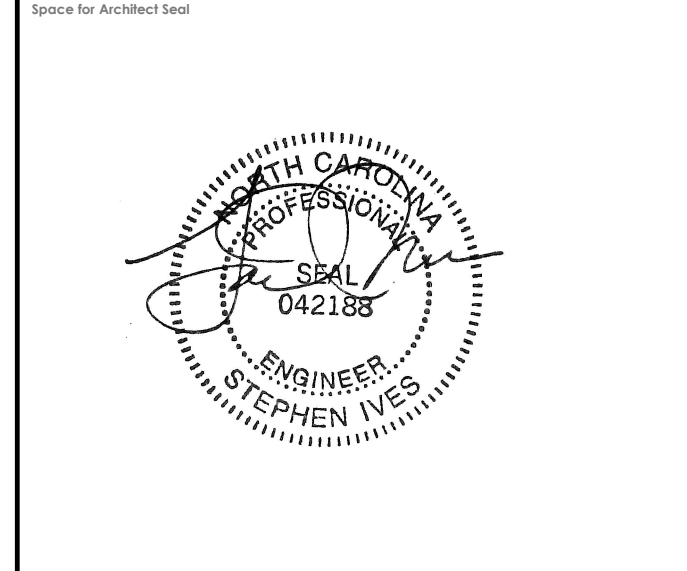

RESIDENCE FOR:
MARKET HOME
 31 CONTENTMANT LANE
 SERENITY

Job Number: STY5-0064-00	Drawing Date: 02/06/2023	Coord Name: GREG P.	Coord Phone: 859-578-4355
House Name: the GRACE			Contract Drawn By: MSA
Drawing Scale: 1/8" = 1'0"			Series: CLASSIC
Born on Date: 11/11/22			CDs Drawn By: CLM

<p>Copyright © 2022 (2022) The Drees Company. All Rights Reserved. 7701 Six Forks Road, Suite 132, Raleigh, NC 27615 Phone: [919] 844-9288</p>	<p>Sheet Information</p>	<p>2.01S</p> <p>First Floor Structural Plan Elevation "B"</p>

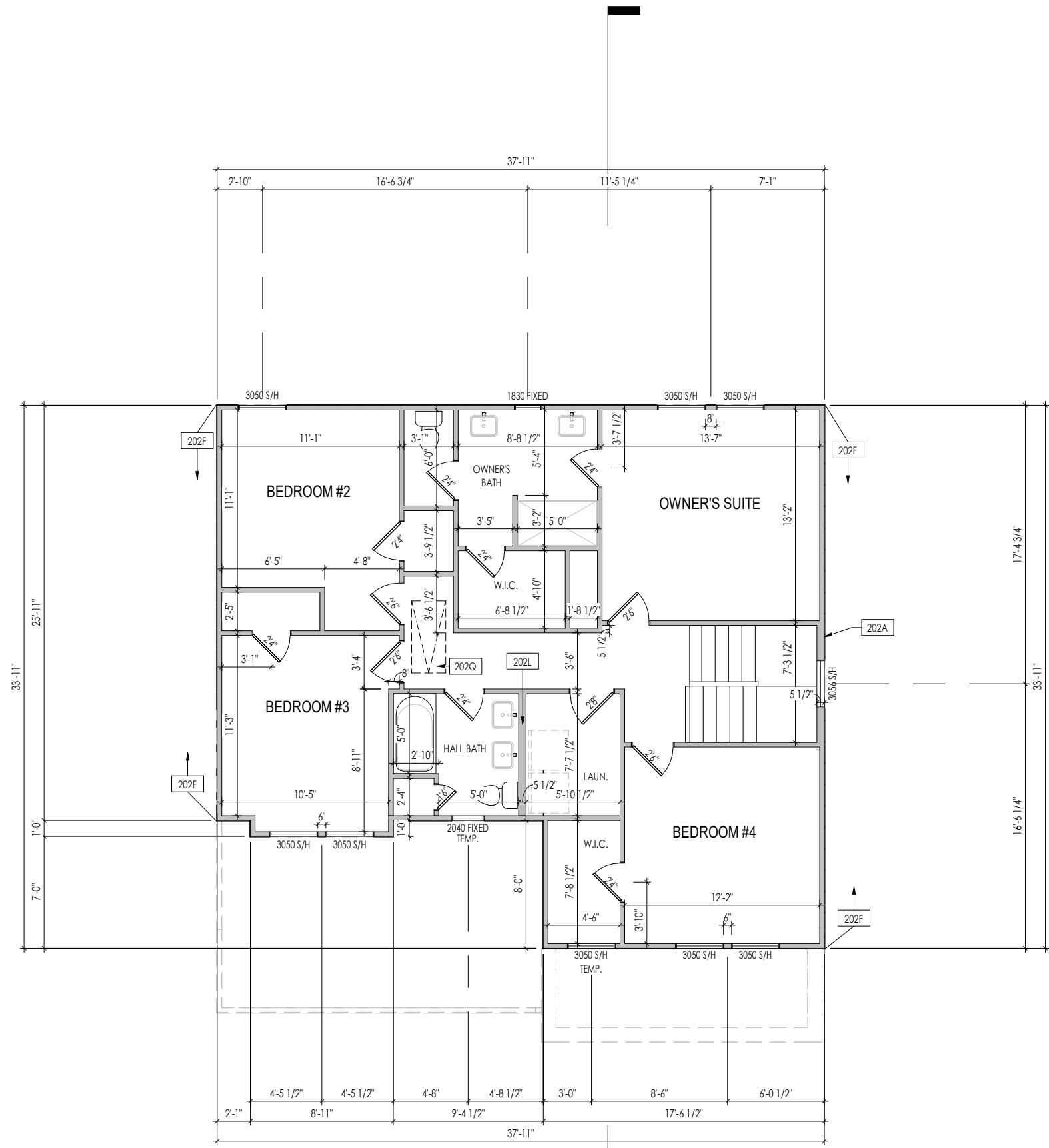

- General Notes:**
1. REFER TO SHEET 0N.1 FOR GENERAL NOTES.
 2. ALL SECOND FLOOR CEILINGS TO BE 9'-1" ABOVE SUBFLOOR UNLESS OTHERWISE NOTED.
 3. FRAME TOP OF ALL WINDOWS AT 1'-0 1/4" BELOW TOP OF PLATE UNLESS OTHERWISE NOTED.
 4. ALL DROPPED, INTERIOR HEADERS (FALSE AND BEARING) ARE DROPPED 1'-0" FROM CEILING.
 5. REFER TO SELECTION SHEETS FOR FLOORING MATERIAL PRIOR TO CONSTRUCTING STAIRS TO DETERMINE RISER HEIGHTS.
 6. REFER TO SHEET 2.02S FOR STRUCTURAL INFORMATION.

Key Notes:

202A	2x6 BALLOON FRAMED WALL - SEE SHEET 2.02S FOR MORE INFO
202F	PROVIDE 1/2" FIRE RATED PLYWOOD THIS SIDE
202L	DO NOT LOCATE TRUSS ABOVE PLUMBING WALL
202Q	PULL DOWN ATTIC ACCESS STAIRS (25-1/2" x 54") WITH LIGHT AND OUTLET

Space for Architect Seal

RESIDENCE FOR:
MARKET HOME
 31 CONTENTMANT LANE
 SERENITY

Job Number: STY5-0064-00	Drawing Date: 02/06/2023	Coord Name: GREG P.	Coord Phone: 859-578-4355
House Name: the GRACE		Drawing Scale: 1/8" = 1'-0"	
Contract Drawn By: MSA		Series: CLASSIC	
Born on Date: 11/11/22		CDs Drawn By: CLM	



Copyright © 2022 (2022) The Drees Company. All Rights Reserved.
 7701 Six Forks Road, Suite 132, Raleigh, NC 27615
 Phone: (919) 844-9288

2.02F
 Second Floor Framing Plan
 Elevation "B"

Sheet Information



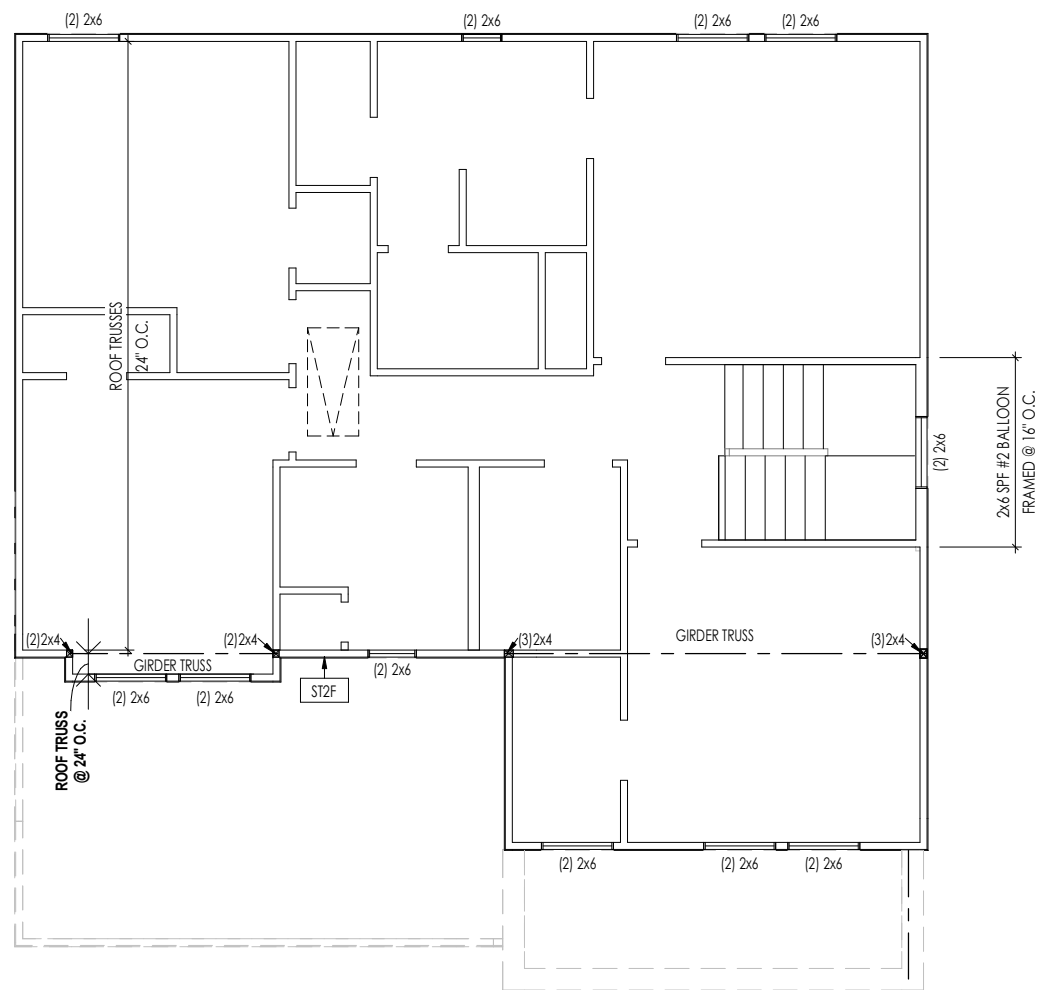

General Notes:

1. REFER TO SHEET ON.1 FOR GENERAL NOTES.

Key Notes:

ST2F PROVIDE CONTINUOUS FULL HEIGHT SHEATHING BEHIND LOW ROOF TRUSSES TO SOLE PLATE

CONNECTION SPECIFICATIONS (TYP. U.N.O.)

NOTE: 10d NAIL = 3" x 0.131" GUN NAIL

JOIST TO SOLE PLATE	(3) 10d TOENAILS
SOLE PLATE TO JOIST/BLK'G.	10d NAILS @ 6" o.c.
STUD TO SOLE PLATE	(3) 10d TOENAILS
TOP OR SOLE PLATE TO STUD	(3) 10d NAILS
RIM TO TOP PLATE	10d TOENAILS @ 6" o.c.
BLK'G. BTWN. JOISTS TO TOP PL.	(3) 10d TOENAILS
RAFTER/TRUSS TO TOP PLATE	(3) 10d TOENAILS + (1) SIMPSON H2.5A
GAB. END TRUSS TO DBL. TOP PL.	10d TOENAILS @ 8" o.c.
R.T. w/ HEEL HT. 9 1/4" TO 12"	2x10 BLK EVERY 3RD BAY FASTENED TO DBL. TOP PLATE w/ 10d TOENAILS @ 6" O.C.
R.T. w/ HEEL HT. 12" TO 16"	2x12 BLK EVERY 3RD BAY FASTENED TO DBL. TOP PLATE w/ 10d TOENAILS @ 6" O.C.
R.T. w/ HEEL HT. UP TO 24"	LAP WALL SHTG. w/ DBL. TOP PL. & INSTALL ON TRUSS VERT. - FASTEN w/ 8d NAILS @ 6" O.C.
R.T. w/ HEEL HT. 24" TO 48"	LAP WALL SHTG. w/ DBL. TOP PL. & INSTALL ON TRUSS VERT. - FASTEN w/ 8d NAILS @ 6" O.C. PROVIDE 2x BLK @ EA. BAY AT TOP OF HEEL
DOUBLE STUD	10d NAILS @ 24" o.c.
DOUBLE TOP PLATE	10d NAILS @ 24" o.c.
DOUBLE TOP PLATE LAP SPLICE	(10) 10d NAILS IN LAPPED AREA
TOP PLATE LAP @ CORNERS & INTERSECTING WALLS	(2) 10d NAILS
WALL TO FOUNDATION	WALL SHTG. LAP w/ SILL PL. & FASTENED PER SHEAR WALL FASTENING SPEC.

Space for Architect Seal

Professional Engineer Seal for Stephen Ives, North Carolina, License No. 042188.

RESIDENCE FOR:
MARKET HOME
 31 CONTENTMANT LANE
 SERENITY

Job Number: STY5-0064-00	Drawing Date: 02/06/2023	Coord Name: GREG P.	Coord Phone: 859-578-4355
House Name: the GRACE			Contract Drawn By: MSA
Born on Date: 11/11/22			CDs Drawn By: CLM
Drawing Scale: 1/8" = 1'0"			Series: CLASSIC
Plan No.:			

Drees HOMES
 Copyright © 2022 (2022) The Drees Company. All Rights Reserved.
 7701 Six Forks Road, Suite 132, Raleigh, NC 27615
 Phone: [919] 844-9288

Sheet Information

2.02S
 Second Floor Structural Plan
 Elevation "B"

HEEL CUT STANDARDS		
	OVERHANG	
	1'-0"	2'-0"
4:12	3-3/4"	7-3/4"
5:12	4-3/4"	9-3/4"
6:12	5-3/4"	11-3/4"
7:12	6-3/4"	13-3/4"
8:12	7-3/4"	N/A
9:12	8-3/4"	N/A
10:12	9-3/4"	N/A
12:12	11-3/4"	N/A
14:12	13-3/4"	N/A

General Notes:

- REFER TO SHEET ON.1 FOR GENERAL NOTES.

Key Notes:

204A VALLEY TRUSS OVER FRAMING @ 24" O.C.

204C NO ROOF DECKING UNDER OVER-FRAMING IN THIS AREA TO ALLOW FOR PROPER ATTIC VENTILATION

204F 4'-0" (MIN.) OF FIRE RETARDANT TREATED ROOF SHEATHING. NO PENETRATION ALLOWED WITHIN 4'-0" OF EXTERIOR WALL - SEE H/7.01 FOR THE FIRE BLOCKING AT SOFFIT

CONNECTION SPECIFICATIONS (TYP. U.N.O.)

NOTE: 10d NAIL = 3" x 0.131" GUN NAIL

JOIST TO SOLE PLATE	(3) 10d TOENAILS
SOLE PLATE TO JOIST/BLK'G.	10d NAILS @ 6" o.c.
STUD TO SOLE PLATE	(3) 10d TOENAILS
TOP OR SOLE PLATE TO STUD	(3) 10d NAILS
RIM TO TOP PLATE	10d TOENAILS @ 6" o.c.
BLK'G. BTWN. JOISTS TO TOP PL.	(3) 10d TOENAILS
RAFTER/TRUSS TO TOP PLATE	(3) 10d TOENAILS + (1) SIMPSON H2.5A
GAB. END TRUSS TO DBL. TOP PL.	10d TOENAILS @ 8" o.c.
R.T. w/ HEEL HT. 9 1/4" TO 12"	2x10 BLK EVERY 3RD BAY FASTENED TO DBL. TOP PLATE w/ 10d TOENAILS @ 6" O.C.
R.T. w/ HEEL HT. 12" TO 16"	2x12 BLK EVERY 3RD BAY FASTENED TO DBL. TOP PLATE w/ 10d TOENAILS @ 6" O.C.
R.T. w/ HEEL HT. UP TO 24"	LAP WALL SHTG. w/ DBL. TOP PL. & INSTALL ON TRUSS VERT. - FASTEN w/ 8d NAILS @ 6" O.C.
R.T. w/ HEEL HT. 24" TO 48"	LAP WALL SHTG. w/ DBL. TOP PL. & INSTALL ON TRUSS VERT. - FASTEN w/ 8d NAILS @ 6" O.C. PROVIDE 2x BLK @ EA. BAY AT TOP OF HEEL
DOUBLE STUD	10d NAILS @ 24" o.c.
DOUBLE TOP PLATE	10d NAILS @ 24" o.c.
DOUBLE TOP PLATE LAP SPLICE	(10) 10d NAILS IN LAPPED AREA
TOP PLATE LAP @ CORNERS & INTERSECTING WALLS	(2) 10d NAILS
WALL TO FOUNDATION	WALL SHTG. LAP w/ SILL PL. & FASTENED PER SHEAR WALL FASTENING SPEC.

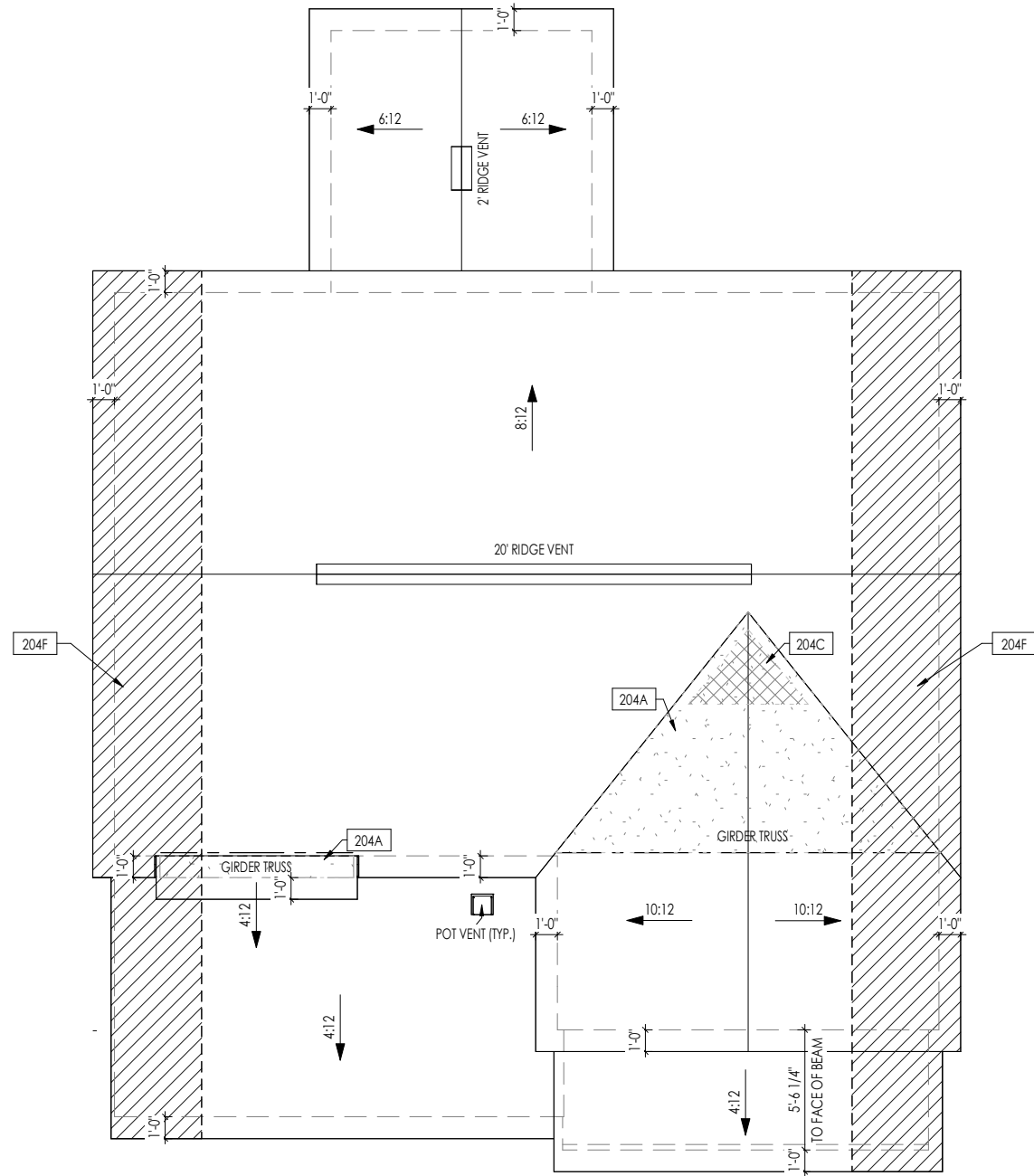

ROOF VENTILATION			
CITY/SERIES:	RALEIGH		
	MAIN HOUSE	GARAGE	PATIO
TOTAL ATTIC AREA:	1,280	229	169
REQUIRED NET FREE VENTILATION (ATTIC AREA/300):	4.27	0.76	0.56
ACTUAL NET FREE VENTILATION (UPPER + LOWER):	5.49	1.97	1.51
DOWNSPOUT CALCULATION			
	MAIN HOUSE	GARAGE	PATIO
TOTAL DRAINABLE ROOF AREA:	1664	297.7	219.7
MINIMUM # OF DOWNSPOUTS:	3	1	1

Space for Architect Seal

RESIDENCE FOR:
MARKET HOME
31 CONTENTMANT LANE
SERENITY

Job Number: STY5-0064-00	Drawing Date: 02/06/2023	Coord Name: GREG P.	Coord Phone: 859-578-4355
House Name: the GRACE		Drawing Scale: 1/8" = 1'0"	
Contract Drawn By: MSA		Series: CLASSIC	
Born on Date: 11/11/22		CDs Drawn By: CLM	

Drees HOMES
7701 Six Forks Road, Suite 132, Raleigh, NC 27615
Phone: (919) 844-9288

Sheet Information

2.04
Roof Plan
Elevation "B"

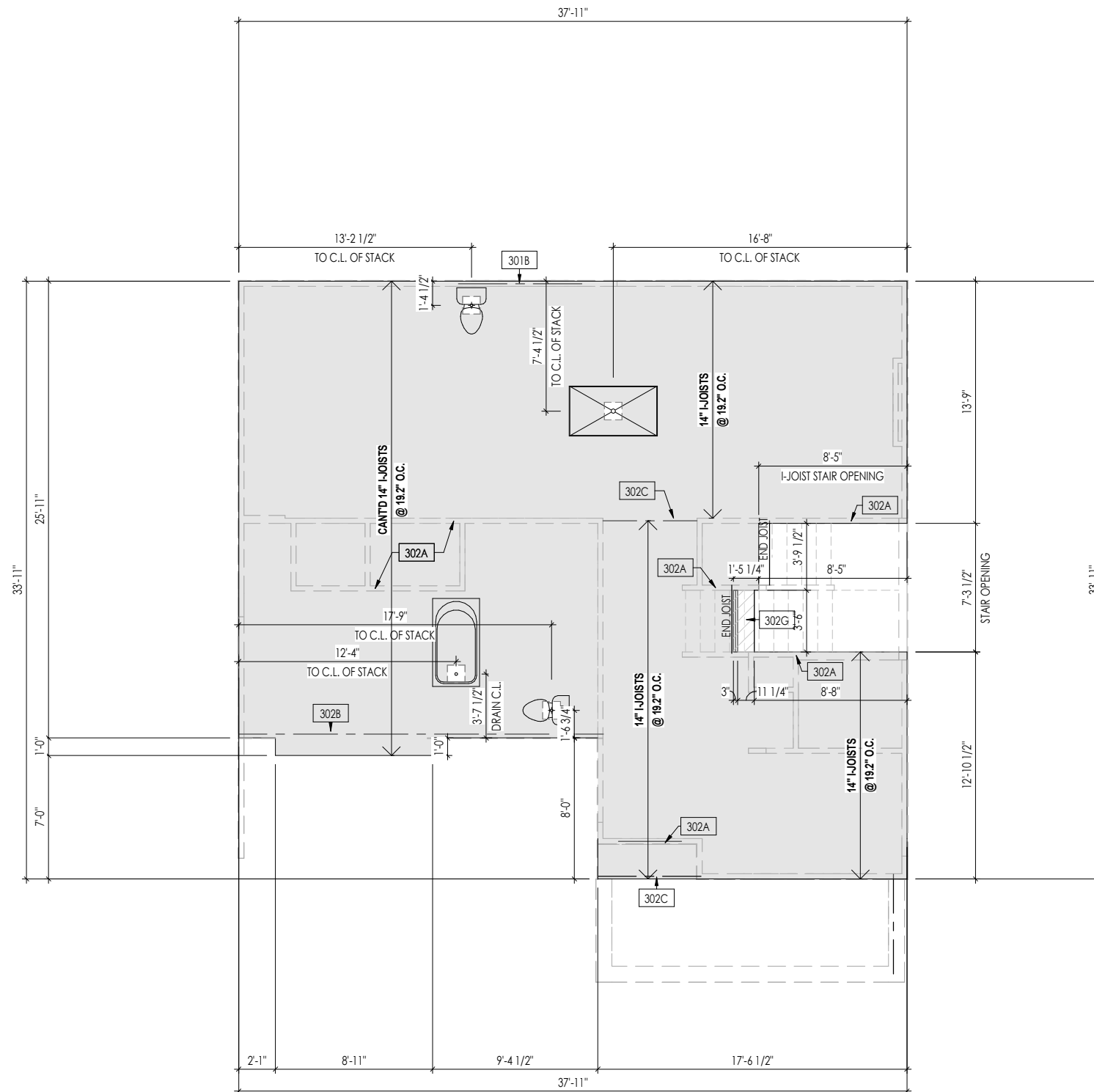

General Notes:

1. REFER TO SHEET 0N.1 FOR GENERAL NOTES.
2. FLOOR JOISTS TO BE 14" TJI 210 SERIES I-JOISTS, OR EQUAL, @ 19.2" O.C., UNLESS OTHERWISE NOTED.
3. JOISTS ARE NOT TO BE PLACE DIRECTLY OVER INTERIOR PARALLEL WALL. (TO PREVENT UNEVEN FLOOR DEFLECTION FROM OCCURRING)
4. ADD'L JOISTS MAY BE LOCATED UP TO 2" AWAY FROM THE PARTITION WALL ABOVE IN CASES WHERE MECHANICAL PENETRATIONS

Key Notes:

302A	BEARING WALL BELOW
302B	BEAM BELOW - SEE SHEET 2.01S FOR MORE INFO
302C	FLUSH BEAM - SEE SHEET 2.01S FOR MORE INFO
302G	(2)2x8 (TOP FLUSH) NEXT TO 2x12 FLAT FRAME FOR STAIR HEADROOM - SEE DETAIL X/X.XX

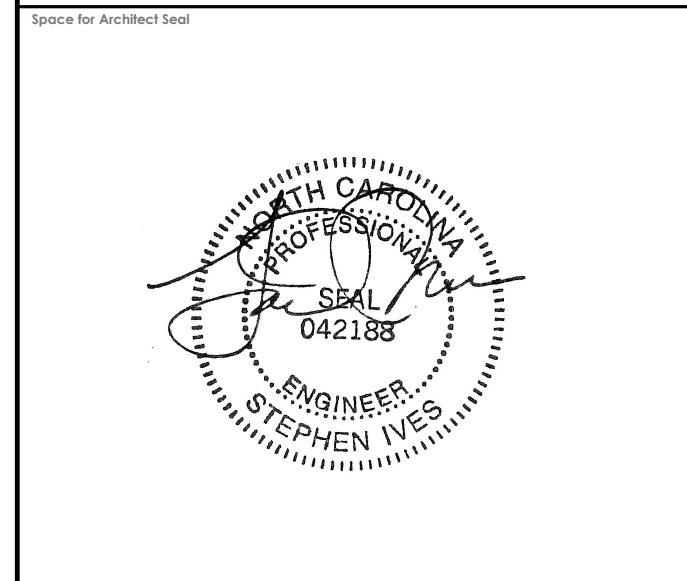

RESIDENCE FOR:
MARKET HOME
 31 CONTENTMANT LANE
 SERENITY

Job Number: STY5-0064-00	Drawing Date: 02/06/2023	Coord Name: GREG P.	Coord Phone: 859-578-4355
House Name: the GRACE		Drawing Scale: 1/8" = 1'0"	
Contract Drawn By: MSA		Series: CLASSIC	
Born on Date: 11/11/22		CDs Drawn By: CLM	

<p>Copyright © 2022 (2022) The Drees Company. All Rights Reserved. 7701 Six Forks Road, Suite 132, Raleigh, NC 27615 Phone: [919] 844-9288</p>	<p>Sheet Information</p>	<h1>3.02</h1> <p>Second Floor Subfloor Plan Elevation "B"</p>

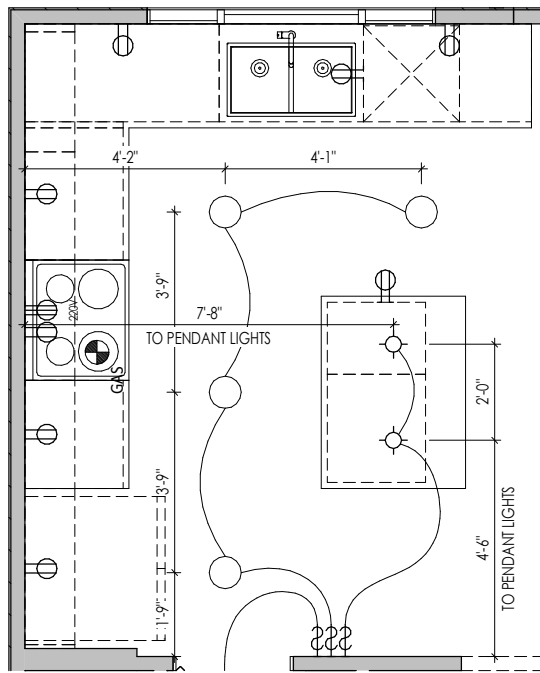

A
4.01
KITCHEN LIGHTING DETAIL
1/4" = 1'-0"

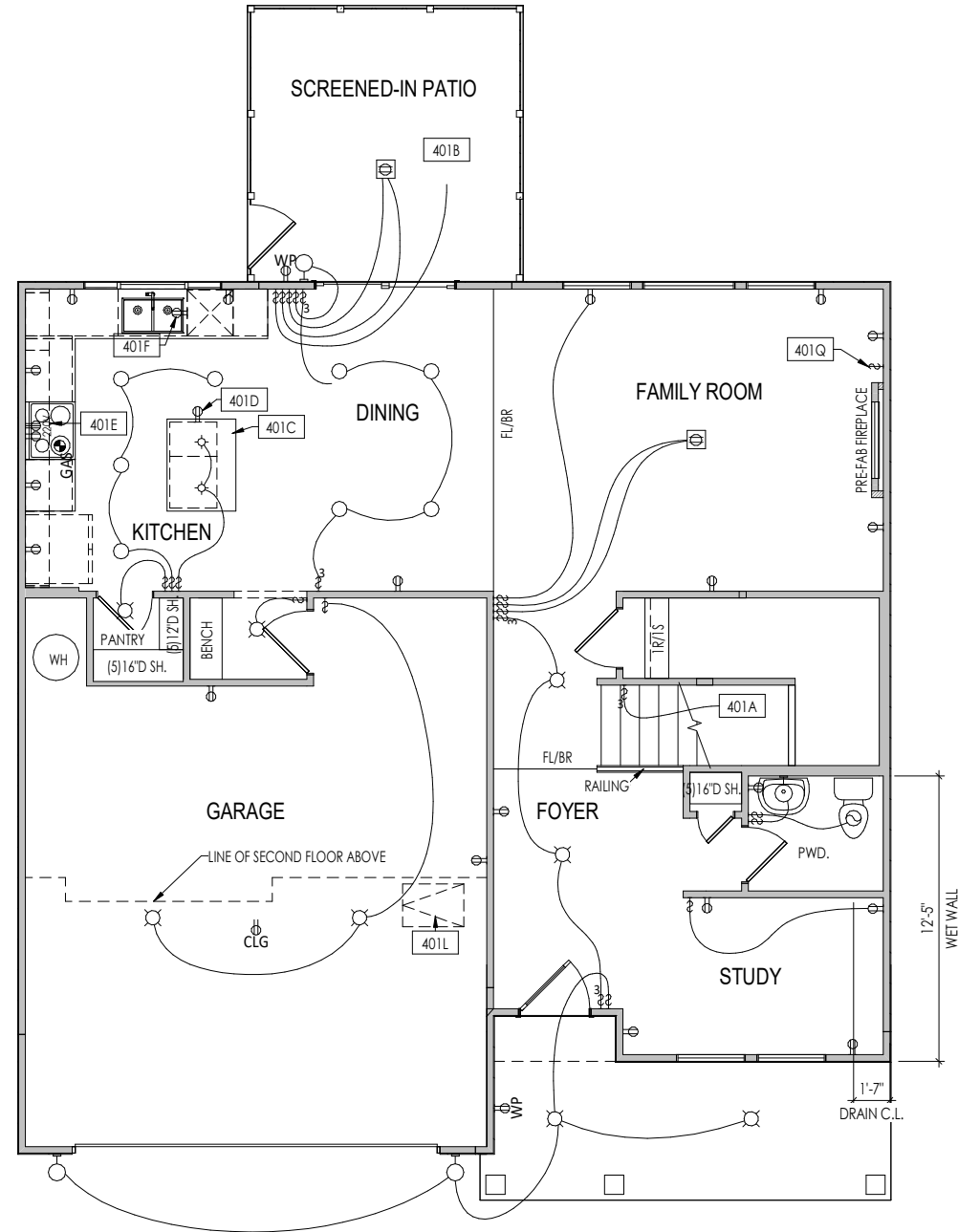
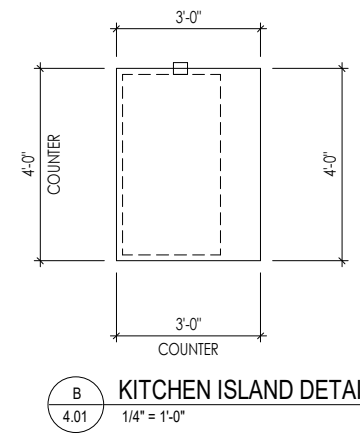

General Notes:

- REFER TO SHEET ON.1 FOR GENERAL NOTES.

Key Notes:

401A	TO SWITCH OR LIGHT ABOVE
401B	TO (2) TWIN FLOOD LIGHTS ABOVE
401C	SEE DETAIL A/4.01 FOR KITCHEN ISLAND COUNTERTOP DIMENSIONS
401D	HOLD OUTLET HIGH ON ISLAND
401E	OUTLET FOR RANGE HOOD/MICROWAVE HELD HIGH - VENT TO EXTERIOR
401F	OUTLET FOR DISHWASHER LOCATED IN SINK CABINET
401L	22-1/2" x 32" ATTIC ACCESS PANEL IN CEILING
401Q	SWITCHES FOR BLOWER UNIT WITH DIRECT VENT FIREPLACE

MECHANICAL LEGEND

◀ PHONE JACK	○ CLG. MOUNTED LIGHT FIXT.	■ STAIR LIGHT
⊕ WALL OUTLET	○ SURFACE MOUNT DISC LIGHT OR RECESSED CEILING LIGHT, PER SPECS.	+ HOSE BIB
☀ WEATHERPROOF GFCI OUTLET	○ WALL MOUNTED LIGHT FIXT.	△ SHOWER HEAD
⊕ 220 VOLT OUTLET	⊕ DOUBLE SPOTLIGHT FIXT.	⊕ GAS HOOK UP
⊕ GFCI OUTLET	⊕ DIRECTIONAL CAN LIGHT	⊕ FLOOR DRAIN
⊕ FLOOR OUTLET	⊕ PIN LIGHT	⊕ SMOKE DETECTOR
⊕ CABLE TELEVISION JACK	⊕ WALL SCONCE @ 5'-6" A.F.F.	⊕ CO DETECTOR
⊕ SINGLE POLE SWITCH	⊕ FLUORESCENT LIGHT	⊕ SMOKE DETECTOR/CO DETECTOR COMBINATION
⊕ 3-WAY SWITCH	⊕ UNDER CABINET LIGHTING	⊕ EXHAUST FAN AND LIGHT COMBINATION
⊕ 4-WAY SWITCH		⊕ CLG. MTD. EXHAUST FAN
⊕ BLOCK, MOUNT, & SWITCH FOR FUTURE FAN/LIGHT COMBINATION (CENTER, UNLESS OTHERWISE NOTED)		

Space for Architect Seal

**RESIDENCE FOR:
MARKET HOME
31 CONTENTMANT LANE
SERENITY**

Job Number: STY5-0064-00	Drawing Date: 02/06/2023	Coord Name: GREG P.	Coord Phone: 859-578-4355
House Name: the GRACE			Contract Drawn By: MSA
Born on Date: 11/11/22			Series: CLASSIC
CDs Drawn By: CLM			Plan No.:

<p>Drees HOMES SM</p> <p><small>Copyright © 2022 (2022) The Drees Company. All Rights Reserved. 7701 Six Forks Road, Suite 132, Raleigh, NC 27615 Phone: [919] 844-9288</small></p>	<p>Sheet Information</p>	<h1>4.01</h1> <p>First Floor Mechanical Plan Elevation "B"</p>

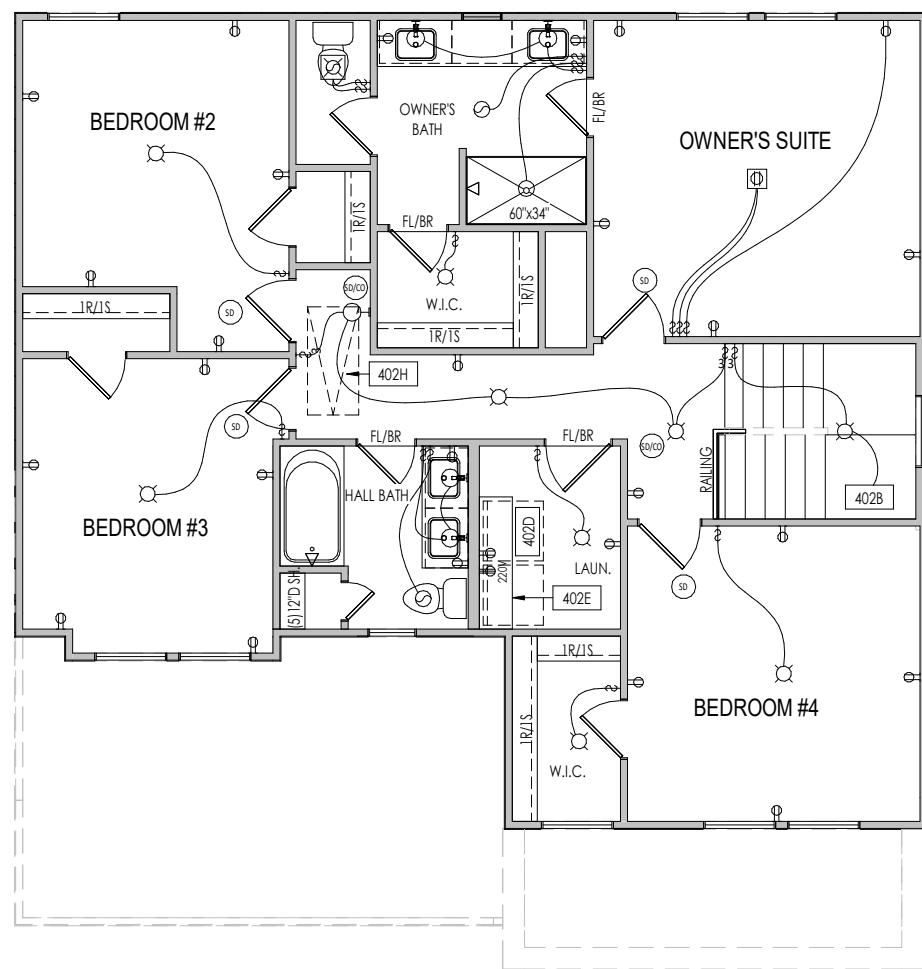

General Notes:

1. REFER TO SHEET ON.1 FOR GENERAL NOTES.

Key Notes:

402B TO SWITCH OR LIGHT BELOW

402D LOCATE WASHER TO LEFT OF DRYER

402E 16" DEEP x 5'-6" LONG SHELF HELD AT 5'-7" A.F.F.

402H PULL DOWN ATTIC ACCESS STAIRS W/ LIGHT AND OUTLET

MECHANICAL LEGEND

◀ PHONE JACK	○ CLG. MOUNTED LIGHT FIXT.	■ STAIR LIGHT
⊖ WALL OUTLET	○ SURFACE MOUNT DISC LIGHT OR RECESSED CEILING LIGHT, PER SPECS.	+ HOSE BIB
⊖ WEATHERPROOF GFCI OUTLET	○ WALL MOUNTED LIGHT FIXT.	△ SHOWER HEAD
⊖ 220 VOLT OUTLET	⊖ DOUBLE SPOTLIGHT FIXT.	⊖ GAS GAS HOOK UP
⊖ GFCI OUTLET	⊖ DIRECTIONAL CAN LIGHT	⊖ FLOOR DRAIN
⊖ FLOOR OUTLET	⊖ PIN LIGHT	⊖ SMOKE DETECTOR
⊖ CABLE TELEVISION JACK	⊖ WALL SCONCE @ 5'-6" A.F.F.	⊖ CO DETECTOR
⊖ SINGLE POLE SWITCH	⊖ FLUORESCENT LIGHT	⊖ SMOKE DETECTOR/CO DETECTOR COMBINATION
⊖ 3-WAY SWITCH	⊖ UNDER CABINET LIGHTING	⊖ EXHAUST FAN AND LIGHT COMBINATION
⊖ 4-WAY SWITCH		⊖ CLG. MTD. EXHAUST FAN
⊖ BLOCK, MOUNT, & SWITCH FOR FUTURE FAN/LIGHT COMBINATION (CENTER, UNLESS OTHERWISE NOTED)		

Space for Architect Seal

RESIDENCE FOR:
MARKET HOME
 31 CONTENTMANT LANE
 SERENITY

Job Number: STY5-0064-00	Drawing Date: 02/06/2023	Coord Name: GREG P.	Coord Phone: 859-578-4355
House Name: the GRACE			Contract Drawn By: MSA
Born on Date: 11/11/22			Series: CLASSIC
CDs Drawn By: CLM			Plan No.:

<p>Copyright © 2022 (2022) The Drees Company. All Rights Reserved. 7701 Six Forks Road, Suite 132, Raleigh, NC 27615 Phone: (919) 844-9288</p>	Sheet Information	4.02
		Second Floor Mechanical Plan Elevation "B"

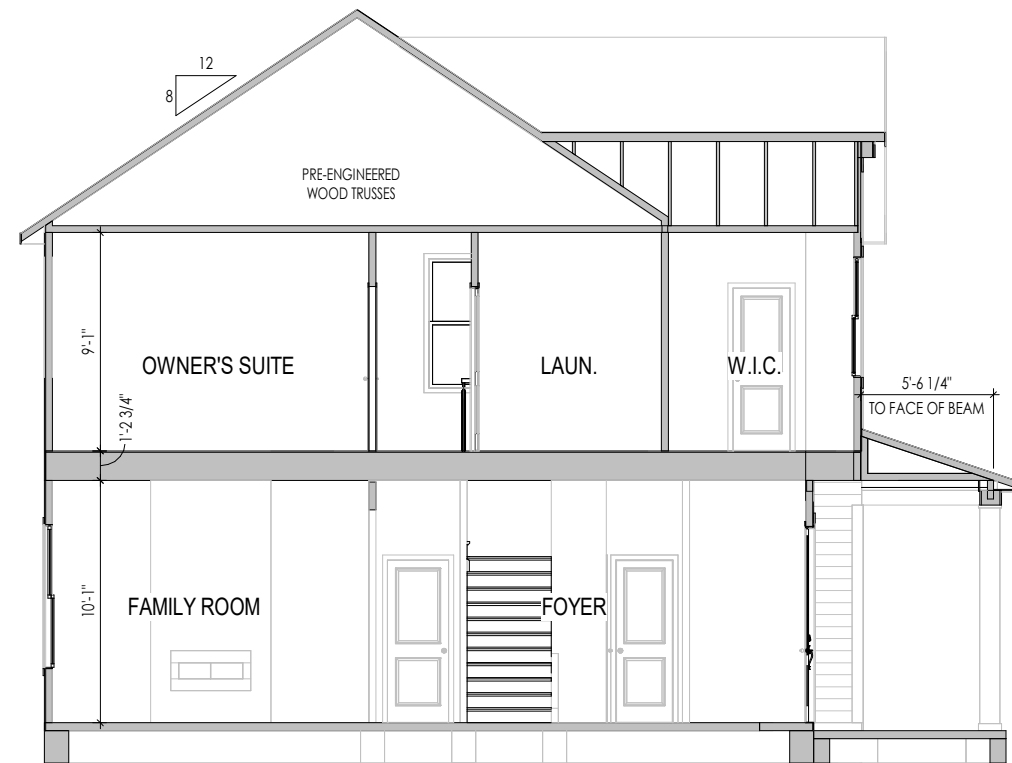

A Building Section Thru Foyer
5.01 1/8" = 1'-0"

General Notes:

1. REFER TO SHEET ON.1 FOR GENERAL NOTES.

Key Notes:

Space for Architect Seal

RESIDENCE FOR:
MARKET HOME
31 CONTENTMANT LANE
SERENITY

Job Number: STY5-0064-00	Drawing Date: 02/06/2023	Coord Name: GREG P.	Coord Phone: 859-578-4355
------------------------------------	------------------------------------	-------------------------------	-------------------------------------

House Name:	Drawing Scale: 1/8" = 1'0"	Contract Drawn By: MSA
-------------	----------------------------	----------------------------------

the GRACE	Series: CLASSIC
------------------	---------------------------

Born on Date:	11/11/22	CDs Drawn By:	CLM	Plan No.:	-
---------------	----------	---------------	-----	-----------	---

Sheet Information

5.01
Building Section
Elevation "B"

TYPICAL TRIM:
6" FASCIA (ALL SIDES)
8" FRIEZE (FRONT ONLY, UNLESS OTHERWISE NOTED)

General Notes:

- REFER TO SHEET ON.1 FOR GENERAL NOTES.
- ROOFING MATERIAL PER SELECTIONS.
- CONTACT M&K ENGINEERING FOR HEADER SIZE/BRICK SUPPORT IF GRADE DROPS AND THE AMOUNT OF BRICK OVER GARAGE DOOR SHOWN ON CURRENT ELEVATION IS NO LONGER ACCURATE

Key Notes:

BRICK and STONE LINTEL SCHEDULE

	SPAN	36" HIGH	48" HIGH	LINTEL SIZE	WINDOW ABOVE
*BRICK	Up to 6'-0"	---	---	L3 1/2 x 3 1/2 x 1/4	---
	Up to 8'-3"	---	---	L5 x 3 1/2 x 5/16	---
	Up to 9'-3"	---	---	L6 x 4 x 5/16	L7 x 4 x 3/8
	Up to 16'-3"	L7 x 4 x 3/8	L8 x 4 x 1/2	L8 x 4 x 1/2	**per Design
*STONE	Up to 6'-0"	---	---	L4 x 3 1/2 x 1/4	---
	Up to 8'-3"	---	---	L5 x 3 1/2 x 5/16	---
	Up to 9'-3"	---	L6 x 4 x 3/8	L7 x 4 x 3/8	**per Design
	Up to 16'-3"	---	L8 x 4 x 1/2	**per Design	**per Design

All Lintels: 4" Minimum bearing required each end
 * Brick is based on 40psf and Stone is based on 60psf
 ** Any lintels not described by the above parameters shall be specifically designed.



ELEVATION 'B'

Space for Architect Seal

RESIDENCE FOR:
MARKET HOME
 31 CONTENTMANT LANE
 SERENITY

Job Number: STY5-0064-00	Drawing Date: 02/06/2023	Coord Name: GREG P.	Coord Phone: 859-578-4355
House Name: the GRACE			Contract Drawn By: MSA
Born on Date: 11/11/22			CDs Drawn By: CLM
Series: CLASSIC			Plan No.:

<p>Drees HOMES SM</p> <p><small>Copyright © 2022 (2022) The Drees Company. All Rights Reserved. 7701 Six Forks Road, Suite 132, Raleigh, NC 27615 Phone: (919) 844-9288</small></p>	Sheet Information	6.01
		Front Elevation Elevation "B"

TYPICAL TRIM:
6" FASCIA (ALL SIDES)
8" FRIEZE (FRONT ONLY, UNLESS OTHERWISE NOTED)

General Notes:

1. REFER TO SHEET ON.1 FOR GENERAL NOTES.
2. ROOFING MATERIAL PER SELECTIONS.
3. REFER TO LINTEL SCHEDULE AS NEEDED ON SHEET 6.01.

Key Notes:

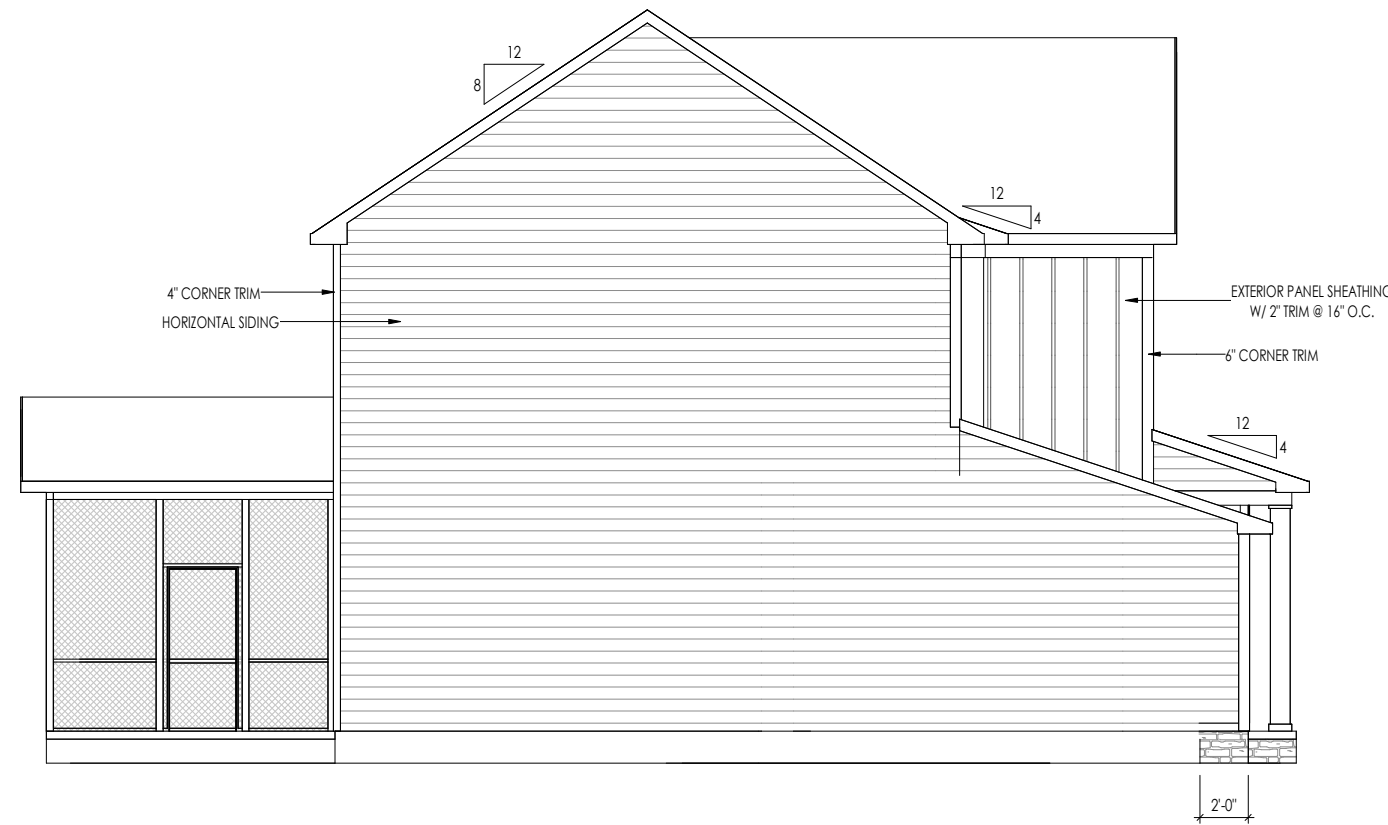

Space for Architect Seal

RESIDENCE FOR:
MARKET HOME
31 CONTENTMANT LANE
SERENITY

Job Number: STY5-0064-00	Drawing Date: 02/06/2023	Coord Name: GREG P.	Coord Phone: 859-578-4355
House Name: the GRACE		Drawing Scale: 1/8" = 1'0"	
Contract Drawn By: MSA		Series: CLASSIC	
Born on Date: 11/11/22		CDs Drawn By: CLM	

Drees HOMES
SM
Copyright © 2022 (2022) The Drees Company. All Rights Reserved.
7701 Six Forks Road, Suite 132, Raleigh, NC 27615
Phone: (919) 844-9288

Sheet Information

6.02
Garage Side Elevation
Elevation "B"

TYPICAL TRIM:
6" FASCIA (ALL SIDES)
8" FRIEZE (FRONT ONLY, UNLESS OTHERWISE NOTED)

General Notes:

1. REFER TO SHEET ON.1 FOR GENERAL NOTES.
2. ROOFING MATERIAL PER SELECTIONS.
3. REFER TO LINTEL SCHEDULE AS NEEDED ON SHEET 6.01.

Key Notes:



Space for Architect Seal

RESIDENCE FOR:
MARKET HOME
31 CONTENTMANT LANE
SERENITY

Job Number: STY5-0064-00	Drawing Date: 02/06/2023	Coord Name: GREG P.	Coord Phone: 859-578-4355
House Name: the GRACE		Drawing Scale: 1/8" = 1'0"	
		Contract Drawn By: MSA	
		Series: CLASSIC	
Born on Date: 11/11/22		CDs Drawn By: CLM	

<p>Drees HOMES SM</p> <p><small>Copyright © 2022 (2022) The Drees Company. All Rights Reserved. 7701 Six Forks Road, Suite 132, Raleigh, NC 27615 Phone: [919] 844-9288</small></p>	Sheet Information	6.03
		Rear Elevation Elevation "B"

TYPICAL TRIM:
6" FASCIA (ALL SIDES)
8" FRIEZE (FRONT ONLY, UNLESS OTHERWISE NOTED)

General Notes:

1. REFER TO SHEET 0N.1 FOR GENERAL NOTES.
2. ROOFING MATERIAL PER SELECTIONS.
3. REFER TO LINTEL SCHEDULE AS NEEDED ON SHEET 6.01.

Key Notes:

Space for Architect Seal



RESIDENCE FOR:
MARKET HOME
31 CONTENTMANT LANE
SERENITY

Job Number: STY5-0064-00	Drawing Date: 02/06/2023	Coord Name: GREG P.	Coord Phone: 859-578-4355
House Name: the GRACE			Contract Drawn By: MSA
Born on Date: 11/11/22			CDs Drawn By: CLM
Series: CLASSIC			Plan No.: -

<p>Drees HOMES SM</p> <p><small>Copyright © 2022 (2022) The Drees Company. All Rights Reserved. 7701 Six Forks Road, Suite 132, Raleigh, NC 27615 Phone: (919) 844-9288</small></p>	Sheet Information	6.04
		Side Elevation Elevation "B"

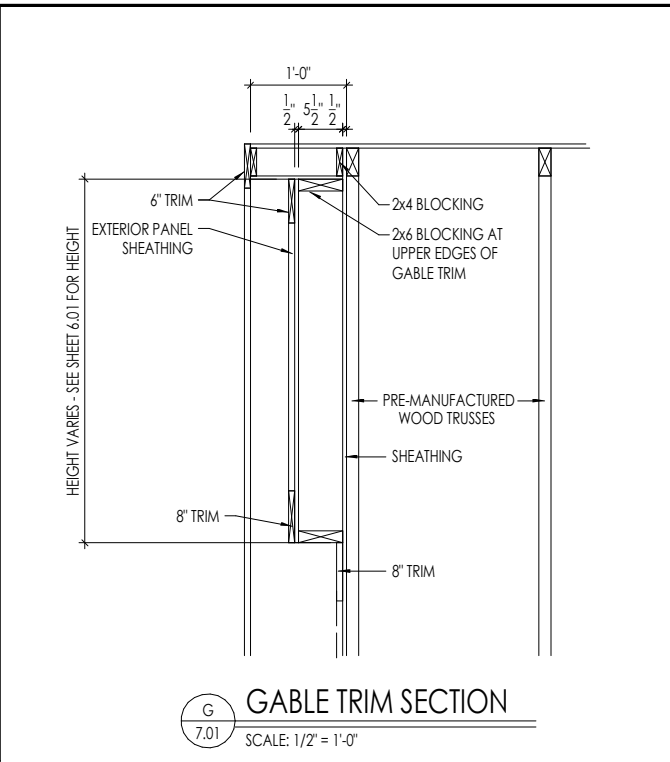
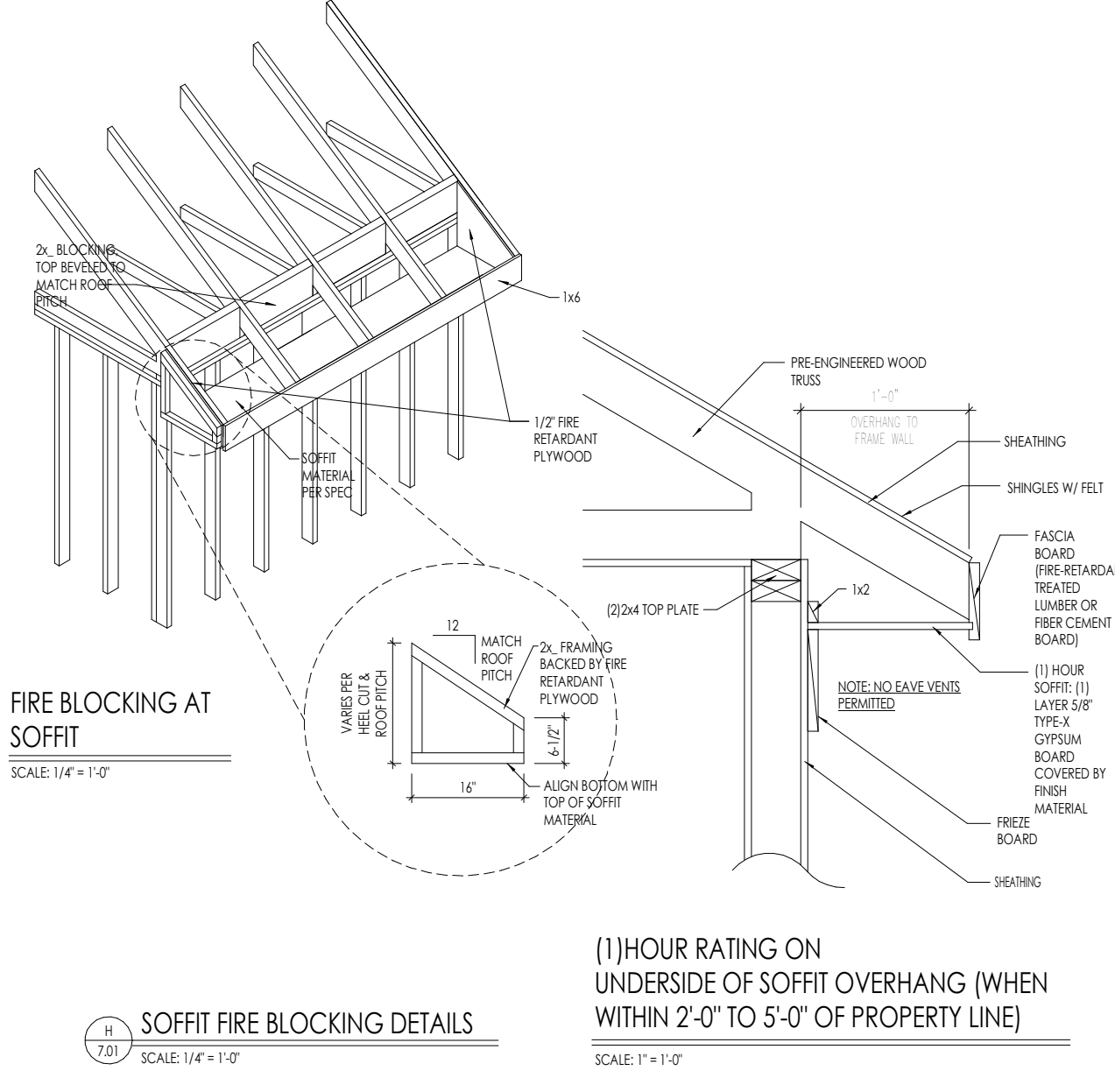
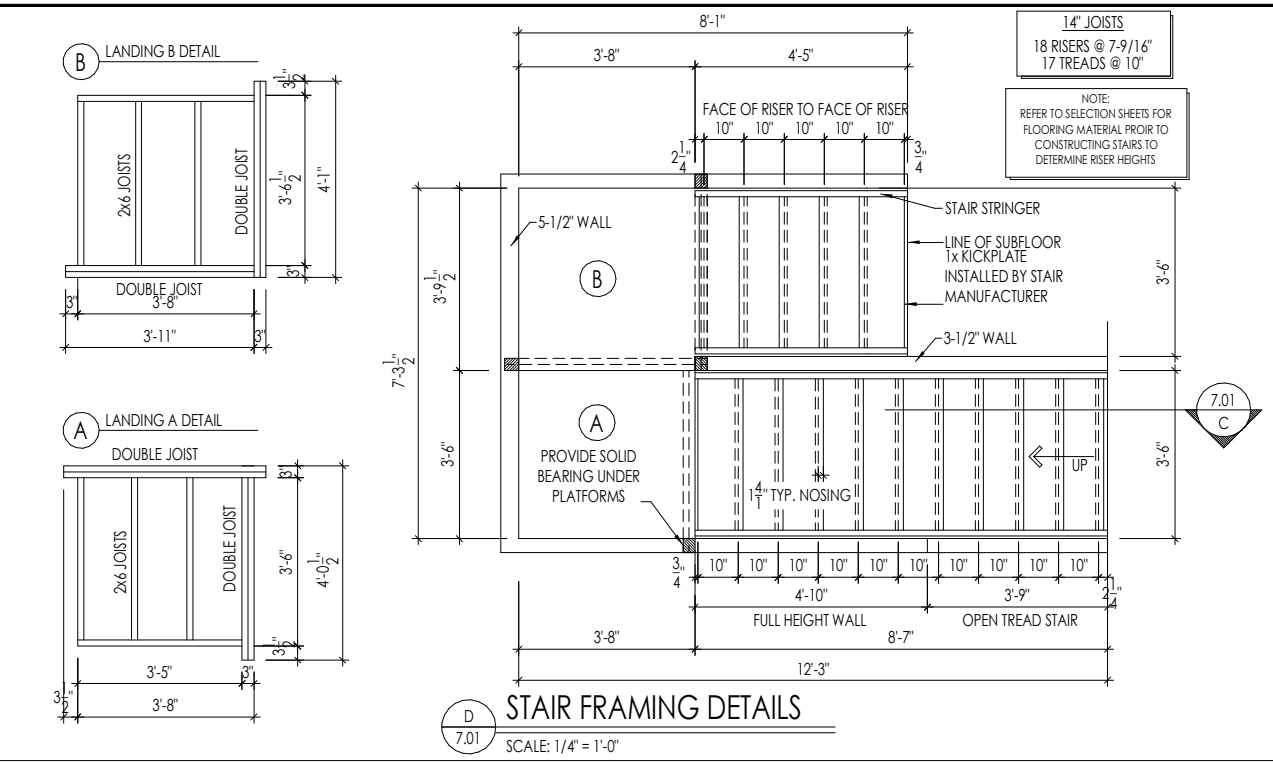
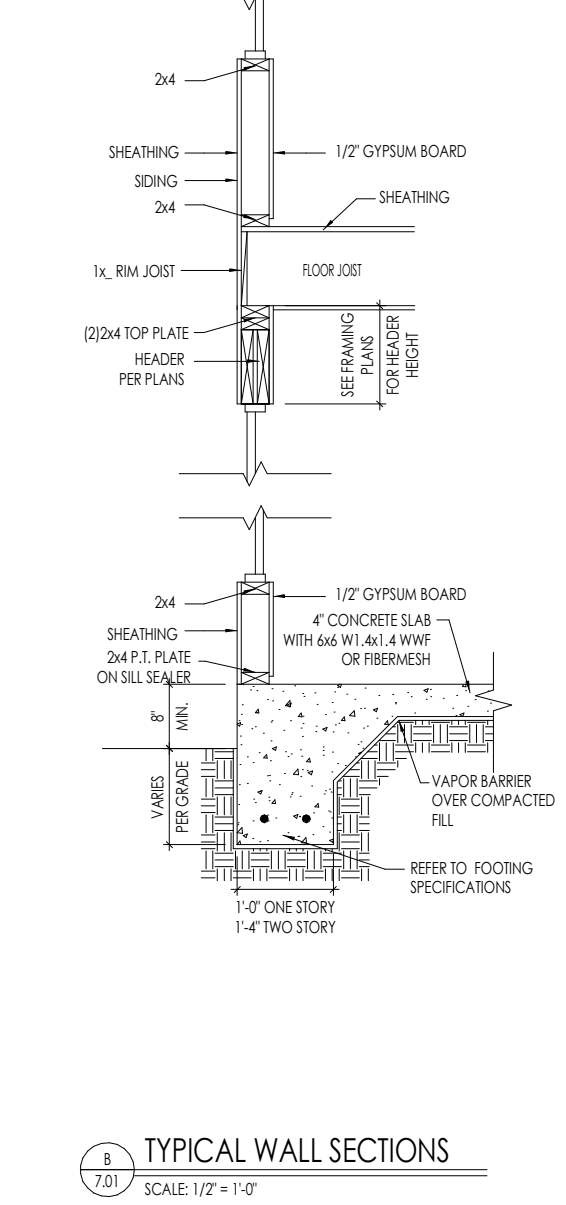
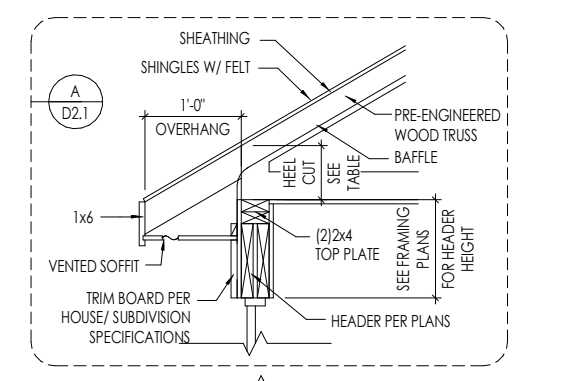
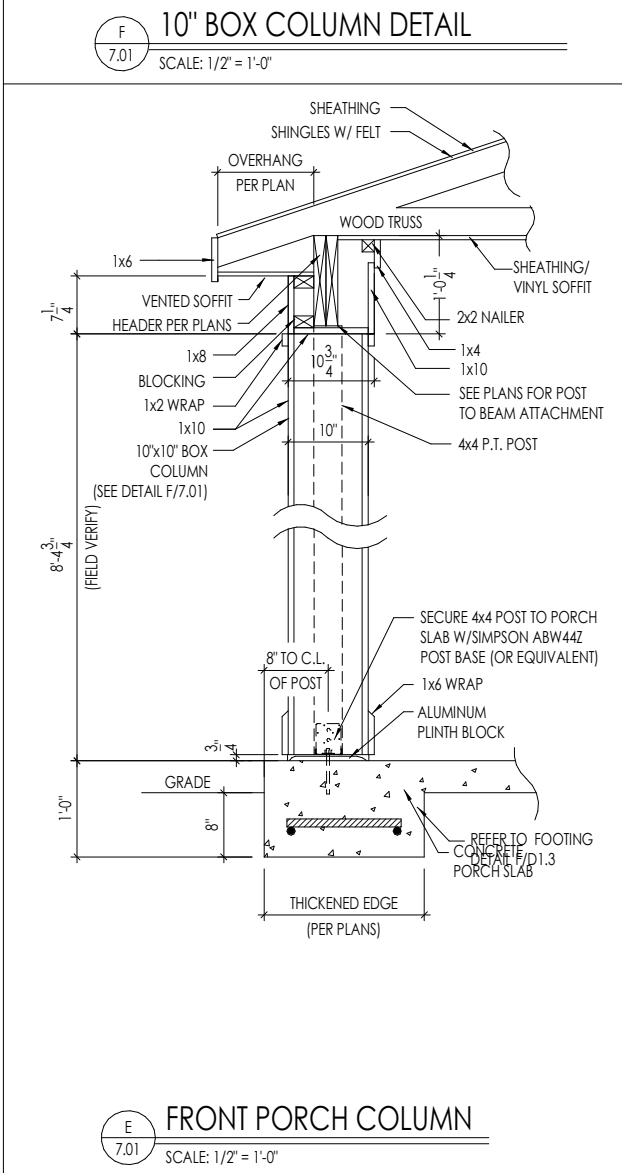
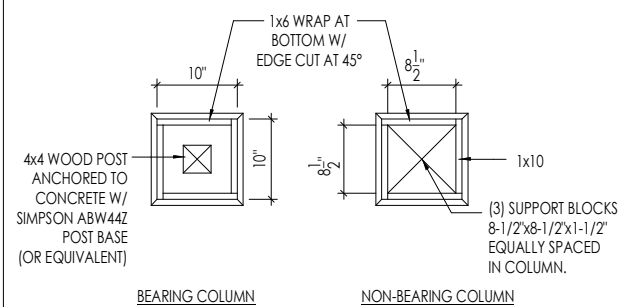
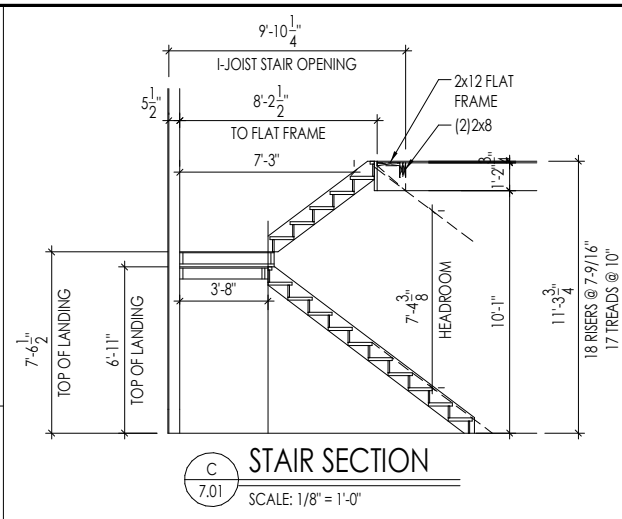
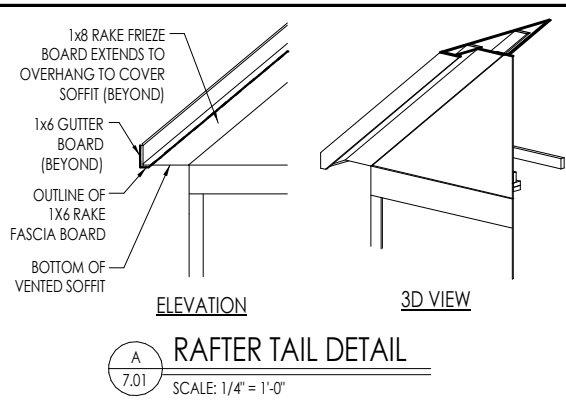

Space for Architect Seal

RESIDENCE FOR: MARKET HOME
31 CONTENTMANT LANE
SERENITY

Job Number: STY5-0064-00	Drawing Date: 02/06/2023	Coord Name: GREG P.	Coord Phone: 859-578-4355
House Name: the GRACE			Contract Drawn By: MSA
Born on Date: 11/11/22			CDs Drawn By: CLM

Drees HOMES
7701 Six Forks Road, Suite 132, Raleigh, NC 27615
Phone: [919] 844-9288

7.01
House Specific Details
Elevation "B"

CONNECTION SPECIFICATIONS (TYP. U.N.O.)

NOTE: 10d NAIL = 3" x 0.131" GUN NAIL

JOIST TO SOLE PLATE	(3)10d TOENAILS
SOLE PLATE TO JOIST/BLK'G.	10d NAILS @ 6" o.c.
STUD TO SOLE PLATE	(3)10d TOENAILS
TOP OR SOLE PLATE TO STUD	(3)10d NAILS
RIM TO TOP PLATE	10d TOENAILS @ 6" o.c.
BLK'G. BTWN. JOISTS TO TOP PL.	(3)10d TOENAILS
RAFTER/TRUSS TO TOP PLATE	(3)10d TOENAILS + (1) SIMPSON H2.5A
GAB. END TRUSS TO DBL. TOP PL.	10d TOENAILS @ 6" o.c.
R.T. w/ HEEL HT. 9 1/4" TO 12"	2x10 BLK EVERY 3RD BAY FASTENED TO DBL. TOP PLATE w/ 10d TOENAILS @ 6" o.c.
R.T. w/ HEEL HT. 12" TO 16"	2x12 BLK EVERY 3RD BAY FASTENED TO DBL. TOP PLATE w/ 10d TOENAILS @ 6" o.c.
R.T. w/ HEEL HT. UP TO 24"	LAP WALL SHTG. w/ DBL. TOP PL. & INSTALL ON TRUSS VERT. - FASTEN w/ 8d NAILS @ 6" o.c.
R.T. w/ HEEL HT. 24" TO 48"	LAP WALL SHTG. w/ DBL. TOP PL. & INSTALL ON TRUSS VERT. - FASTEN w/ 8d NAILS @ 6" o.c. PROVIDE 2x BLK @ EA. BAY AT TOP OF HEEL
DOUBLE STUD	10d NAILS @ 24" o.c.
DOUBLE TOP PLATE	10d NAILS @ 24" o.c.
DOUBLE TOP PLATE LAP SPLICE	(10)10d NAILS IN LAPPED AREA
TOP PLATE LAP @ CORNERS & INTERSECTING WALLS	(2)10d NAILS
WALL TO FOUNDATION	WALL SHTG. LAP w/ SILL PL. & FASTENED PER SHEAR WALL FASTENING SPEC.

GARAGE SLAB
4" CONG. SLAB w/ 6x6-WI.4xWI.4 WVF ON 6 MIL VAPOR BARRIER ON 4" MIN. GRANULAR FILL ON 95% COMPACTED FILL/VIRGIN SOIL
PORCH SLAB
4" CONG. SLAB w/ 6x6-WI.4xWI.4 WVF ON 95% COMPACTED FILL/VIRGIN SOIL
BASEMENT SLAB
4" CONG. SLAB ON 6 MIL VAPOR BARRIER ON 4" MIN. GRANULAR FILL ON 95% COMPACTED FILL/VIRGIN SOIL
SLAB ON GRADE
4" CONG. SLAB w/ 6x6-WI.4xWI.4 WVF ON 6 MIL VAPOR BARRIER ON 4" MIN. GRANULAR FILL ON 95% COMPACTED FILL/VIRGIN SOIL

VENEER LINTEL SCHEDULE

SPAN (MAX)	HEIGHT OF VENEER ABOVE LINTEL	STEEL ANGLE SIZE
3'-0"	20 FT. MAX	L3"x3"x1/4"
6'-0"	3 FT. MAX	L3"x3"x1/4"
	12 FT. MAX	L4"x3"x1/4"
8'-0"	20 FT. MAX	L5"x3"x3/8"
	3 FT. MAX	L4"x4"x1/4" *
9'-6"	12 FT. MAX	L5"x3"x3/8"
	16 FT. MAX	L6"x3"x3/8"
16'-0"	12 FT. MAX	L7"x4"x1/2" **
	3 FT. MAX	L8"x4"x1/2" **

ALL LINTELS:
 - SHALL SUPPORT 2 3/4" - 3 1/2" VENEER w/ 40 psf MAXIMUM HEIGHT.
 - 10" SHALL HAVE 4" MIN. BEARING
 - 12" SHALL HAVE 6" MIN. BEARING
 - 16" SHALL NOT BE FASTENED BACK TO HEADER.
 - 18" SHALL BE FASTENED BACK TO HOOD HEADER IN WALL @ 48" o.c. w/ 1/2" DIA. x 3 1/2" LONG LAG SCREWS IN 2" LONG VERTICALLY SLOTTED HOLES.
 - MAX. VENEER HT. APPLIES TO ANY PORTION OF BRICK OVER THE OPENING.
 - ALL LINTELS SHALL BE LONG LESS VERTICAL.
 - WHEN SUPPORTING VENEER < 3" WIDE THE EXTERIOR TOE OF THE HORIZONTAL LEG MAY BE CUT IN THE FIELD TO BE 3 1/2" WIDE OVER THE BEARING LENGTH ONLY. THIS IS TO ALLOW FOR MORTAR JOINT FINISHING.
 - SEE STRUCTURAL PLANS FOR ANY LINTEL CONDITION NOT ENCOMPASSED BY THE ABOVE PARAMETERS.
 * FOR GREEN VENEER USE L4xM4.
 ** FOR 3/2" VENEER ONLY. SEE PLAN FOR VENEER SUPPORT IF VENEER < 3/2" THICK.
 MKC STD. - MAY 2006

LEGEND

- ◻ INTERIOR BEARING WALL
- ▬ BEARING WALL ABOVE
- ▬ BEAM / HEADER
- ◻ EXTENT OF OVERFRAMING
- J.L. METAL HANGER
- INDICATES EXTENT OF INT. OSB SHEARWALL, BLOCKED PANEL EDGES, AND/OR 3" O.C. EDGE NAILING
- ▶ INDICATES HOLDDOWN
- * INDICATES POST ABOVE (P.A.) PROVIDE SOLID BLOCKING UNDER POST OR JAMB ABOVE.

ADDITIONAL NOTES FOR TRUSS & I-JOIST MANUFACTURER

ROOF TRUSS, FLOOR TRUSS AND ENGINEERED JOISTS SHALL BE DESIGNED TO MEET THE DEFLECTION CRITERIA BELOW, UNLESS NOTED OTHERWISE ON PLAN. MULHERN & KULP CANNOT BE HELD RESPONSIBLE FOR ANY STRUCTURAL ISSUES RELATED TO ANY BUILDING COMPONENT IF COMPONENT SHOP DRAWINGS ARE NOT SUBMITTED TO MKK FOR REVIEW PRIOR TO FABRICATION, DELIVERY, OR INSTALLATION.

TRUSSES/JOISTS SHALL BE DESIGNED SO THAT DIFFERENTIAL DEFLECTION BETWEEN ADJACENT PARALLEL TRUSSES/JOISTS OR GIRDER TRUSSES/FLUSH BEAMS DO NOT EXCEED THE FOLLOWING:

A. ROOF TRUSSES:
 1/4" DEAD LOAD
 B. FLOOR TRUSSES, ATTIC TRUSSES, & I-JOISTS:
 1/8" DEAD LOAD

ABSOLUTE DEAD LOAD DEFLECTION OF FLOOR TRUSSES/ATTIC TRUSSES WHEN ADJACENT TO FLOOR FRAMING BY OTHERS SHALL BE LIMITED TO 3/16". (NOT DIFFERENTIAL DEFLECTION)

GENERAL STRUCTURAL NOTES

FOUNDATION

- DESIGN IS BASED ON 2019 OHIO RESIDENTIAL CODE.
- FOOTING DESIGN - 1500 PSF NET ALLOWABLE SOIL BEARING PRESSURE IS ASSUMED. BUILDER/CONTRACTOR MUST VERIFY.
- FASTEN 2x6 SILL PLATES TO CONG. FND WITH A MINIMUM OF 2 ANCHORS PER PLATE, 12" MAX. FROM PLATE ENDS - UTILIZING:
 - 1/2" DIA. ANCHOR BOLTS @ 6'-0" O.C., 1" MIN. EMBEDMENT
 - SIMPSON MAB STRAPS @ 32" O.C.
 - SIMPSON MASA ANCHOR STRAPS @ 6'-0" O.C.
- ALL LUMBER EXPOSED TO WEATHER OR IN CONTACT W/ PERIMETER FOUNDATION SHALL BE PRESERVATIVE-TREATED SOUTHERN PINE #2.
- BUILDER TO VERIFY CORROSION-RESISTANCE COMPATIBILITY OF HARDWARE & FASTENERS IN CONTACT W/ PRESERVATIVE-TREATED WOOD. CONTACT LUMBER & HARDWARE SUPPLIERS TO COORD.
- FOUNDATION WALLS & FOOTINGS SHALL BE PLAIN CONCRETE, U.N.O.
- CONCRETE DESIGN BASED ON ACI 318. CONCRETE SHALL ATTAIN THE FOLLOWING MIN. COMPRESSIVE STRENGTHS IN 28 DAYS, U.N.O.:
 - F_c = 4000 psi: FOUNDATION WALLS
 - 3000 psi: FOOTINGS & INTERIOR SLABS ON GRADE
 - 3500 psi: GARAGE & EXTERIOR SLABS ON GRADE
 - f_y = 60,000 psi
- BASEMENT FOUNDATION WALL DESIGN BASED ON:
 - 8" OR 9" HEIGHT (AS NOTED ON PLANS)
 - TALLER WALLS MUST BE ENGINEERED.
 - NOMINAL WIDTH (8" FOR 8' WALL, 10" FOR 10' WALL).
- BASEMENT WALL DESIGN IS BASED ON 30 OR 45 PCF BACKFILL SOIL TYPE CLASSIFICATIONS:
 - 30 PCF TYPE (GM, GP, SM, SP)
 - 45 PCF TYPE (GM, GC, SM, SM-SG, ML)
 - IMPORTANT - IF 60 PCF SOIL TYPE (SG, ML-CL, OR CL) IS UTILIZED FOR BACKFILL, CONTACT MULHERN & KULP FOR FURTHER EVALUATION OF FOUNDATION DESIGN.
- BASEMENT WALLS SHALL BE BRACED, PRIOR TO BACKFILLING, BY ADEQUATE TEMPORARY BRACING OR INSTALL 1st FLOOR DECK.
- PROVIDE (2) #5 BARS AROUND ALL SIDES OF OPENINGS IN CONCRETE BSMT. FND. WALL WITH 2" CLEAR. REINFORCEMENT SHALL EXTEND 12" PAST CORNER OF OPENING IN ALL DIRECTIONS.
 - FOR OPENINGS UP TO 36", PROVIDE MINIMUM 10" CONCRETE DEPTH OVER OPENING OR (3)2x10 W/(2)2x6 JACK STUDS, U.N.O.
 - LARGER OPENINGS SHALL BE PER PLAN.
- ALL CONCRETE EXPOSED TO THE WEATHER SHALL NOT HAVE LESS THAN 5% OR MORE THAN 7% AIR ENTRAINMENT.
- ALL FOOTINGS SHALL BEAR BELOW FROST LINE (TYP.) OR 12" MIN IN REGIONS WHERE CODE FROST DEPTH IS NOT APPLICABLE. CONSULT SOILS REPORT OR BUILDING DEPT. FOR MINIMUM DEPTH BELOW GRADE.
- FOOTINGS AND SLABS ON GRADE SHALL BEAR ON VIRGIN SOIL OR 95% COMPACTED FILL.
- PROVIDE CONTROL JOINTS AT ALL INSIDE CORNERS OF SLAB EDGES, AND OTHER LOCATIONS WHERE SLAB CRACKS ARE LIKELY TO DEVELOP.
 - JOINTS SHALL BE LOCATED @ 10'-0" O.C. (RECOMMENDED) OR 15'-0" O.C. (MAXIMUM)
 - JOINT GRID PATTERN SHALL BE AS CLOSE TO SQUARES AS POSSIBLE (1:1 RATIO), WITH A MAXIMUM OF 1:1.5 RATIO
 - CONTROL JOINTS SHALL NOT BE INSTALLED IN STRUCTURAL SLABS
- TYPICAL REINFORCEMENT DETAILS: PROVIDE 3" MIN. CLEAR COVER WHERE CAST AGAINST EARTH, 1 1/2" MIN. CLEAR COVER AGAINST FORMS. LAP ALL REBAR 48 BAR DIAMETERS MIN. (24" FOR #4 BARS) & BEND BARS AND LAP AT CORNERS. PROVIDE 6" HOOK INTO SUPPORTING FOOTINGS WHEN FOOTINGS INTERSECT.
- DIMENSIONS BY OTHERS, BUILDER TO VERIFY.

MKC STD. - MAY 2002

LATERAL/WALL BRACING & WALL SHEATHING SPECIFICATIONS

THIS MODEL HAS BEEN DESIGNED TO RESIST LATERAL FORCES RESULTING FROM:
120 MPH WIND IN 2018 NCSCB
 (120 MPH WIND SPEED IN ASCE 7-10 WIND MAP, PER IRC R301.2.1.1) EXP. B & SEISMIC CAT. A/B.

EXT. WALL SHEATHING SPECIFICATION

- 7/16" OSB OR 15/32" PLYWOOD:
 FASTEN SHEATHING w/ 2 3/8"x0.113 NAILS @ 6" O.C. AT EDGES & @ 12" O.C. IN THE PANEL FIELD. (TYP. U.N.O.)
- ALL SHEATHING PANELS SHALL BE ORIENTED VERTICALLY (LONG DIRECTION PARALLEL TO STUDS) AND INSTALLED FULL HEIGHT OF SHEAR WALL - OR - 2x HORIZONTAL BLOCKING SHALL BE PROVIDED TO SUPPORT ALL UNSUPPORTED PANEL EDGES & EDGE FASTENING.
- ALL EXT. WALLS SHALL BE CONTINUOUSLY SHEATHED AND ARE CONSIDERED SHEAR WALLS.
- ALT. STAPLE CONNECTION SPEC: 1 3/4" 16 GA STAPLES (1/8" CROWN) @ 3" O.C. AT EDGES & @ 6" O.C. IN FIELD.

3" O.C. EDGE NAILING

- AT DESIGNATED AREAS - FASTEN PANEL EDGES OF WOOD STRUCTURAL WALL SHEATHING TO FRAMING w/ 2 3/8" x 0.113" NAILS @ 3" O.C. AND 12" O.C. IN THE PANEL FIELD. NO STAPLE ALTERNATIVE AVAILABLE AT THIS SPEC. ALL SHEATHING PANELS SHALL BE ORIENTED VERTICALLY (LONG DIRECTION PARALLEL TO STUD) AND INSTALLED FULL HEIGHT OF SHEAR WALL - OR - 2x HORIZONTAL BLOCKING SHALL BE PROVIDED TO SUPPORT UNSUPPORTED PANEL EDGES AND 3" O.C. EDGE FASTENING.

NOTES

- SEE CONNECTION SPECIFICATIONS CHART FOR STANDARD SHEAR TRANSFER DETAILING. IF ADDITIONAL CAPACITY IS REQUIRED BY DESIGN, IT WILL BE SPECIFICALLY NOTED ON PLAN.
- DESIGN ASSUMES 16" O.C. MAX. STUD SPACING, U.N.O.
- ALL STRUCTURAL PANELS ARE TO BE DIRECTLY APPLIED TO STUD FRAMING.
- PRE-MANUFACTURED PANELIZED WALLS:
 FASTEN TOGETHER END STUDS OF WALL PANELS SHEATHED w/ OSB OR PLYWOOD w/ 10d NAILS @ 4" O.C. (THRU ONE SIDE ONLY)

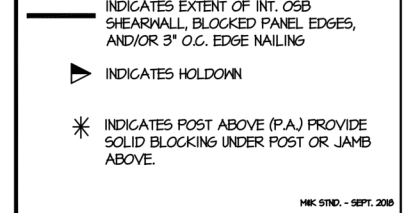

GENERAL STRUCTURAL NOTES

FLOOR FRAMING

- I-JOISTS/TRUSSES SHALL BE DESIGNED BY MANUF. TO MEET OR EXCEED L/480 LIVE LOAD DEFLECTION CRITERIA. (EXCLUDES STONE/MARBLE OR MET BED CONSTRUCTED FLOORS - CONTACT MKK FOR EXCLUDED FLOOR DESIGNS)
- PER THE GUIDELINES OF THE TILE COUNCIL OF NORTH AMERICA (TCNA HANDBOOK), IT SHALL BE THE FLOOR FINISH INSTALLER'S RESPONSIBILITY TO VERIFY THAT THE FINISHES TO BE INSTALLED MATCH THE DESIGN CRITERIA NOTED ABOVE (UNDER "DESIGN LOADS").
- AT I-JOIST FLOORS, PROVIDE 1 1/8" MIN. OSB RIM BOARD.
- METAL HANGERS SHALL BE SPECIFIED BY MANUFACTURER, U.N.O.
- I-JOIST/TRUSS SHOP DWGS. SHALL BE SUBMITTED TO ARCH. & ENG. FOR REVIEW AND APPROVAL PRIOR TO FABRICATION OR DELIVERY.
- FLOOR SHEATHING SHALL BE 23/32" A.P.A. RATED STURD-I-FLOOR® 24" O.C. EXPOSURE 1 (OR APPROVED EQUAL) WITH TONGUE AND GROOVE EDGES. FASTEN TO FRAMING MEMBERS W/ GLUE AND - 2 1/2" x 0.131" NAILS @ 6" o.c. @ PANEL EDGES & @ 12" o.c. FIELD.
 - 2 3/4" x 0.120" NAILS @ 4" O.C. @ PANEL EDGES & @ 8" O.C. FIELD.
 - 2 3/8" x 0.113" NAILS @ 3" O.C. @ PANEL EDGES & @ 6" O.C. IN FIELD.

ROOF FRAMING

- ROOF SHEATHING SHALL BE 7/16" A.P.A. RATED SHEATHING 24/16 EXPOSURE 1 (OR APPROVED EQUAL). FASTEN TO FRAMING MEMBERS - w/ 2 1/2" x 0.131" NAILS @ 6" o.c. @ PANEL EDGES & @ 12" O.C. FIELD.
 - w/ 2 3/8" x 0.120" NAILS @ 4" o.c. @ PANEL EDGES & @ 8" O.C. FIELD.
 - w/ 2 3/4" x 0.113" NAILS @ 3" o.c. @ PANEL EDGES & @ 6" O.C. FIELD.
- WITHIN 48" OF ALL ROOF EDGES, RIDGES, & HIPs FASTEN ROOF SHEATHING FIELDS PER EDGE NAILING SPEC.
- FASTEN EACH ROOF TRUSS TO TOP PLATE W/ SIMPSON H2.5A CLIP (OR APPROVED EQUAL) @ ALL BEARING POINTS. PROVIDE (2) H2.5A CLIPS AT 2-PLY GIRDER TRUSSES, (3) H2.5A CLIPS AT 3-PLY GIRDER TRUSSES & ROOF BEAMS - AT ALL BEARING POINTS.
- METAL HANGERS SHALL BE SPECIFIED BY THE MANUFACTURER, U.N.O.
- ROOF TRUSS SHOP DWGS. SHALL BE SUBMITTED TO ARCH & ENG. FOR REVIEW AND APPROVAL PRIOR TO FABRICATION OR DELIVERY.
- ERECT AND INSTALL ROOF TRUSSES PER ITCA & TPI'S BCSI 1 "GUIDE TO GOOD PRACTICE FOR HANDLING, INSTALLING & BRACING OF METAL PLATE CONNECTED WOOD TRUSSES."
- SUPPORT SHORT SPAN ROOF TRUSSES w/ 2x4 LEDGER FASTENED TO FRAMING w/ (2) 3" x 0.120" NAILS @ 16" O.C. (UP TO 7' SPAN).

MKC STD. - MAR 2016

MULHERN+KULP
 RESIDENTIAL STRUCTURAL ENGINEERING
 300 Brookside Ave, Building 4 • Ambler, PA 19002
 p 215-648-8001 • mulhernkulp.com

GENERAL STRUCTURAL NOTES

- DESIGN IS BASED ON 2018 NORTH CAROLINA RESIDENTIAL CODE.
- WOOD FRAME ENGINEERING IS BASED ON NDS, "NATIONAL DESIGN SPECIFICATION FOR WOOD CONSTRUCTION" - LATEST EDITION.
- DESIGN LOADS:
 ROOF LIVE = 20 PSF (18 PSF REDUCED)
 DEAD = 7 PSF T.C., 10 PSF B.C.
 LOAD DURATION FACTOR = 1.15
 FLOOR LIVE = 40 PSF (30 PSF @ SLEEPING AREAS)
 DEAD = 10 PSF (I-JOISTS & SOLID SAWN)
 ADD'L 10 PSF @ CERAMIC TILE IN KITCHEN, BATHS, SUNROOM, & LAUND.
 SOIL 1,500 PSF ASSUMED ALLOWABLE BEARING PRESSURE (TO BE VERIFIED BY BUILDER)

GENERAL FRAMING

- ALL TYP. NAIL FASTENER REQUIREMENTS ARE NOTED IN STANDARD CONNECTIONS TABLE (IRC TABLE R602.3.11) OR ON PLANS. ALL NAILS SPECIFIED ARE MIN DIAMETER AND LENGTH REQUIRED FOR CONNECTION. ALL HANGER NAILS SHALL BE INSTALLED PER MANUFACTURER'S REQUIREMENTS FOR MAX CHARTED CAPACITY. NOTE: HANGERS USE COMMON NAIL DIAMETERS NOT TYPICAL FRAMING GUN NAILS.
- EXT. & INT. BEARING WALLS SHALL BE 2x4 OR 2x6 (AS SHOWN ON PLANS) @ 16" O.C. 9PF "STUD" GRADE LUMBER, OR BETTER, U.N.O.
 - WALLS OVER 10' TALL SHALL BE PER PLAN.
- ALL INTERIOR BEARING WALLS ARE ASSUMED TO BE SHEATHED w/ 6/12 WALL BOARD (ONE SIDE MIN.) OR PROVIDE MID HT. BLOCKING.
- ALL 2x8, 2x10, & 2x12 HEADERS, BEAMS & OTHER STRUCTURAL MEMBERS SHALL BE S.Y.P. #2 LUMBER, OR BETTER.
- ALL 2x6 HEADERS, BEAMS & OTHER STRUCTURAL MEMBERS SHALL BE 9PF "STUD" GRADE LUMBER, OR BETTER.
- SUPPORT ALL HEADERS/ BEAMS W/ (1)2x JACK STUD & (1)2x KING STUD, MINIMUM.
 - THE NUMBER OF STUDS SPECIFIED AT A SUPPORT INDICATES THE NUMBER OF JACK STUDS REQUIRED, U.N.O.
- ALL NON-BEARING INTERIOR STUD WALLS SHALL BE CONSTRUCTED WITH 2x "STUD" GRADE MEMBERS SPACED @ 24" O.C. (MAX. U.N.O.)
 - HEADERS IN NON-LOAD BEARING WALLS SHALL BE: (1)2x4/6 FLAT @ OPENINGS UP TO 4'; (2)2x4/6 FLAT UP TO 8'.
- ALL FRAMING LUMBER SHALL BE DRIED TO 15% MC (KD-15).
- ENGINEERED LUMBER BEAMS TO MEET OR EXCEED THE FOLLOWING:
 - 'LSL' - Fb=2325 psi; Fv=310 psi; E=1.55x10⁶ psi
 - 'LVL' - Fb=2600 psi; Fv=285 psi; E=2.0x10⁶ psi
- ENGINEERED LUMBER POSTS TO MEET OR EXCEED THE FOLLOWING:
 - 'LVL' - Fb=2400 psi; Fc=11250 psi; E=1.8x10⁶ psi
- FOR 2 & 3 PLY BEAMS OF EQUAL 1 3/4" MAX. WIDTH, FASTEN PLIES TOGETHER WITH 3 ROWS OF 3"x0.120" NAILS @ 8" O.C. OR 2 ROWS 1/4"x3/8" SIMPSON SDS SCREWS (OR 3/8" TRUSSLOK SCREWS) @ 16" O.C. USE A MINIMUM OF 4 ROWS FOR BEAM DEPTHS OF 14" OR GREATER. APPLY FASTENING AT BOTH FACES FOR 3-PLY CONDITION. LOCATE TOP & BOTTOM NAILS/SCREWS 2" FROM EDGE. SOLID 3 1/2" OR 5 1/4" BEAMS ARE ACCEPTABLE. USE 2 ROWS OF NAILS FOR 2x6 & 2x8 MEMBERS.
- FOR 4 PLY BEAMS OF EQUAL 1 3/4" MAX. WIDTH, FASTEN PLIES TOGETHER WITH 3 ROWS OF 1/4"x6" SIMPSON SDS SCREWS (OR 6 3/4" TRUSSLOK SCREWS) @ 16" O.C. USE A MINIMUM OF 4 ROWS FOR BEAM DEPTHS OF 14" OR GREATER. APPLY FASTENING AT BOTH FACES (ONE SIDE ONLY FOR TRUSSLOK SCREWS). LOCATE TOP AND BOTTOM SCREWS 2" FROM EDGE. A SOLID 7" BEAM IS ACCEPTABLE.
- PROVIDE SOLID BLOCKING IN FLOOR SYSTEM UNDER ALL POSTS CONTINUOUS TO FND/BEARING. BLOCKING TO MATCH POST ABOVE.
- FASTEN 2x WOOD PLATES TO TOP FLANGE OF STEEL BEAMS WITH P.A.F.'s (HILTI) XU PINS OR EQUAL) @ 16" O.C. STAGGERED, OR 1/2" DIA. BOLTS @ 48" O.C. STAGGERED.
- STEEL PIPE COLUMN "ASD CAPACITIES" SHALL MEET OR EXCEED THE LOADS PROVIDED AT EACH STEEL PIPE COLUMN LOCATION ON PLAN. COLUMNS ARE TO BE INSTALLED PER THE MANUFACTURER'S REQUIREMENT THAT ACHIEVES THE RATED CAPACITY USED, INCLUDING BUT NOT LIMITED TO POSITIVE CONNECTIONS AT THE TOP AND BOTTOM OF THE COLUMN. TWO COLUMNS MAY BE USED UNDER CONTINUOUS BEAMS TO ACHIEVE THE FULL PLAN SPECIFIED REQUIRED CAPACITY IF INSTALLED CENTERED ON THE EXISTING FOOTING/ PLAN SPECIFIED SINGLE COLUMN LOCATION.

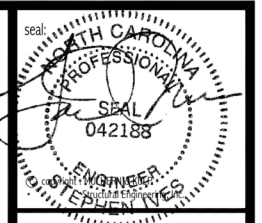

DREES HOMES

Mulhern+Kulp project number:

project mgr: BSM
 drawn by: SMM
 issue date: 12-16-22

REVISIONS:
 date: initial:

MULHERN+KULP
 RESIDENTIAL STRUCTURAL ENGINEERING
 300 Brookside Parkway, Suite 105 • Ambler, PA 19002
 P 215-648-8001 • mulhernkulp.com

STRUCTURAL NOTES

GRACE MODEL

RHL

sheet: **SD-1**

RALEIGH WINDOW SCHEDULE

* MEETS EMERGENCY ESCAPE & RESCUE OPENING REQUIREMENTS

Drees General Callout	Window Type	MI Windows and Doors Capitol Series		Call No.	Rough Opening	Drees General Callout	Call No.	Rough Opening	Call No.	Rough Opening
		Call No.	Rough Opening							
1660	SINGLE/DOUBLE HUNG	CW3500 1/8 x 6/0	20" x 60-1/4"							
1670	SINGLE/DOUBLE HUNG	CW3500 1/8 x 7/0	20" x 84"							
1860	SINGLE/DOUBLE HUNG	CW3500 1/8 x 6/0	20" x 60-1/4"							
2030	SINGLE/DOUBLE HUNG	CW3500 2/0 x 3/0	24" x 36"							
2040	SINGLE/DOUBLE HUNG	CW3500 2/0 x 4/0	24" x 48"							
2050	SINGLE/DOUBLE HUNG	CW3500 2/0 x 5/0	24" x 60-1/4"							
2060	SINGLE/DOUBLE HUNG	CW3500 2/0 x 6/0	24" x 72"							
2070	SINGLE/DOUBLE HUNG	CW3500 2/0 x 7/0	24" x 84"							
2430	SINGLE/DOUBLE HUNG	CW3500 2/4 x 3/0	28" x 36"							
2440	SINGLE/DOUBLE HUNG	CW3500 2/4 x 4/0	28" x 48"							
2450	SINGLE/DOUBLE HUNG	CW3500 2/4 x 5/0	28" x 60-1/4"							
2460	SINGLE/DOUBLE HUNG	CW3500 2/4 x 6/0	28" x 72"							
2830	SINGLE/DOUBLE HUNG	CW3500 2/8 x 3/0	32" x 36"							
2840	SINGLE/DOUBLE HUNG	CW3500 2/8 x 4/0	32" x 48"							
2850	SINGLE/DOUBLE HUNG	CW3500 2/8 x 5/0	32" x 60-1/4"							
* 2860	SINGLE/DOUBLE HUNG	CW3500 2/8 x 6/0	32" x 72"							
3030	SINGLE/DOUBLE HUNG	CW3500 3/0 x 3/0	36-1/4" x 36"							
3040	SINGLE/DOUBLE HUNG	CW3500 3/0 x 4/0	36-1/4" x 48"							
* 3050	SINGLE/DOUBLE HUNG	CW3500 3/0 x 5/0	36-1/4" x 60-1/4"							
* 3060	SINGLE/DOUBLE HUNG	CW3500 3/0 x 6/0	36-1/4" x 72"							
* 3070	SINGLE/DOUBLE HUNG	CW3500 3/0 x 7/0	36-1/4" x 84"							
* 3470	SINGLE/DOUBLE HUNG	CW3500 3/4 x 7/0	40" x 84"							
1050 FIXED		910T 5/0 x 1/0	59-5/8" x 11-1/2"							
1640 FIXED		910T 4/0 x 1/8	47-1/4" x 19-1/2"							
2020 FIXED		CW3500 2/0 x 2/0	24" x 24"							
2030 FIXED		CW3500SL 2/0 x 3/0	24" x 36"							
2040 FIXED		CW3500SL 2/0 x 4/0	24" x 48"							
2050 FIXED		CW3500SL 2/0 x 5/0	24" x 60-1/4"							
2816 FIXED		910TSL 2/6 x 1/8	29-1/4" x 19-1/2"							
2860 FIXED		CW3500 3/0 x 6/0	36" x 72"							
3016 FIXED		910TSL 3/0 x 1/8	35-1/4" x 19-1/2"							
3020 FIXED		910TSL 3/0 x 2/0	35-1/4" x 23-1/2"							
3030 FIXED		CW3500P 3/0 x 3/0	36-1/4" x 36"							
3040 FIXED		CW3500P 3/0 x 4/0	36-1/4" x 48"							
3050 FIXED		CW3500P 3/0 x 5/0	36-1/4" x 60-1/4"							
3060 FIXED		CW3500P 3/0 x 6/0	36-1/4" x 72"							
3070 FIXED		CW3500P 3/0 x 7/0	36-1/4" x 84"							
4010 FIXED		910T 4/0 x 1/0	47-1/4" x 11-1/2"							
4020 FIXED		910T 4/0 x 2/0	47-1/4" x 23-1/2"							
4030 FIXED		CW3500P 4/0 x 3/0	48" x 36"							
4040 FIXED		CW3500P 4/0 x 4/0	48" x 48"							
4044 FIXED		CW3500P 4/0 x 4/4	48" x 52"							
4050 FIXED		CW3500P 4/0 x 5/0	48" x 60-1/4"							
4060 FIXED		CW3500P 4/0 x 6/0	48" x 72"							
4070 FIXED		CW3500P 4/0 x 7/0	48" x 84"							
5030 FIXED		CW3500P 5/0 x 3/0	60" x 36"							
5040 FIXED		CW3500P 5/0 x 4/0	60" x 48"							
5060 FIXED		CW3500P 5/0 x 6/0	60" x 72"							
5070 FIXED		CW3500P 5/0 x 7/0	60" x 84"							
6020 FIXED		910T 6/0 x 2/0	71-5/8" x 23-1/2"							
6050 FIXED		CW3500P 6/0 x 5/0	72" x 60-1/4"							
6060 FIXED		CW3500P 6/0 x 6/0	72" x 72"							
3'-0" HALF ROUND		CW3500 3/0 HC	36-1/4"							
4'-0" HALF ROUND		CW3500 3/0 HC	48"							
5'-0" HALF ROUND		CW3500 3/0 HC	60"							
2020 OCTAGON		CW3500 2/0 OCT	24"							
2'-4" QUARTER ROUND		CW3500 2/4 QC	28"							
3'-0" QUARTER ROUND		CW3500 3/0 QC	36-1/4"							



Drees Homes
 7701 Six Forks Road, Suite 132, Raleigh, NC 27615 PH:(919) 844-9288
 Copyright © 2008, (2013) The Drees Company. All Rights Reserved. No portion of this material may be reproduced in any form or by any means, including photocopying, without the express written permission of the Drees Company. The Drees Company will vigorously prosecute any unauthorized use of this material.

Sheet Description:
WINDOW SCHEDULE

Sheet No.
SC-01

MOULDED MILLWORK SCHEDULE

LAST REVISED 11/22/17

HEADERS		
Drees General Callout	Nuwood	Fypon
ARCHED HEADER D1	H8xxEFR	N/A
ARCHED HEADER D1K	H8xxEFKR	N/A
ARCHED HEADER D2	H8xxEFTR	N/A
ARCHED HEADER D2K	H8xxEFTKR	N/A
ARCHED HEADER D3	AH10xx	WCHSEGxxX10
ARCHED HEADER D3K	N/A	WCHSEGxxX10K
ARCHED HEADER D4	AR5xx	ARxxX6M
ARCHED HEADER D4K	AR5xxK	ARxxX6MK
ARCHED HEADER D5	AR10xxEC	ARxxX6METAR6C
ARCHED HEADER D5K	AR10xxECK	ARxxX6METAR6CK
ARCHED HEADER D6	AR10xxC	ARxxX10MC
ARCHED HEADER D6K	AR10xxCK	ARxxX10MCK
ARCHED HEADER D7K	H7xxEF-4K	N/A
ARCHED HEADER D8	AR14xxC	ARxxX14MC
ARCHED HEADER D8K	AR14xxCK	ARxxX14MCK
ARCHED HEADER D9	H9xxE	WCHAR5xx13
CROSSHEAD A1	H9xx	WCHxxX9N
CROSSHEAD A1K	H9xxK	WCHxxX9NK
CROSSHEAD B1	H14xxBT	WCHxxX14BT
CROSSHEAD B1K	H14xxBTK	WCHxxX14BTK
CROSSHEAD B2	H12xx	WCHxxX12
CROSSHEAD B2K	H12xxK	WCHxxX12K
CROSSHEAD C1	H18xxBT	WCHxxX14BT
CROSSHEAD C1K	H18xxBTK	WCHxxX14BTK
CROSSHEAD C2	H18xxBT-PA	LDCHxxX18
CROSSHEAD C2K	H18xxBTK-PA	LDCHxxX18K
CROSSHEAD Z-E1-HDR	Z-E1-HDR	Z-E1-HDR
CROSSHEAD Z-E2-HDR	Z-E2-HDR	Z-E2-HDR
CROSSHEAD Z-E3-HDR	Z-E3-HDR	Z-E3-HDR
CROSSHEAD Z-E3-ARCHHDR	Z-E3-ARCHHDR	Z-E3-ARCHHDR
CROSSHEAD Z-E3-CLHDR	Z-E3-CLHDR	Z-E3-CLHDR
CROSSHEAD Z-E5-HDR	Z-E5-HDR	Z-E5-HDR
WINDOW HEADER A1	H6xx	WCHxxX6
WINDOW HEADER A1K	H6xxK	WCHxxX6K
WINDOW HEADER B1	H9xx-2	WCHxxX9N
WINDOW HEADER B1K	H9xx-2K	WCHxxX9NK
WINDOW HEADER B2	H9xxBT	WCHxxX10NBT
WINDOW HEADER B2K	H9xxBTK	WCHxxX10NBTK
WINDOW HEADER C1	H9xx	CCAxX10
WINDOW HEADER C1K	H9xxK	CCAxX10K
WINDOW HEADER C2	H9xxT	WCHxxX9T
WINDOW HEADER C2K	H9xxTK	WCHxxX9TK
WINDOW HEADER C3	H12xxBT	WCHxxX10BT
WINDOW HEADER C3K	H12xxBTK	WCHxxX10BTK
WINDOW HEADER C4	H14xxBT	WCHxxX14BT
WINDOW HEADER D1	H7xxF-4	N/A
WINDOW HEADER D1K	H7xxF-4K	N/A
WINDOW HEADER D2K	H9xxK-1	N/A
WINDOW HEADER Z-W1	Z-W1	Z-W1
WINDOW HEADER Z-W3	Z-W3	Z-W3
WINDOW HEADER Z-W3K	Z-W3K	Z-W3K
WINDOW HEADER Z-W3D	Z-W3D	Z-W3D
WINDOW HEADER Z-W4	Z-W4	Z-W4
WINDOW HEADER Z-W4K	Z-W4K	Z-W4K

PILASTERS		
Drees General Callout	Nuwood	Fypon
FLUTED PILASTER A1	PL7xxF	PIL7Xxx
FLUTED PILASTER B1	PL9xxF	PIL9Xxx
FLUTED PILASTER C1	PL11xxFM	PIL11Xxx
PANEL PILASTER A2	PL7xxP	PIL7XxxDP
PANEL PILASTER B2	PL9xxP	PIL9XxxDP
PANEL PILASTER C2	PL11xxPM	PIL11XxxDP
PILASTER D1	M311-9	PIL10XxxA
PILASTER D2	M323-9	N/A
PILASTER Z-E1-PIL	Z-E1-PIL	Z-E1-PIL
PILASTER Z-E2-PIL	Z-E2-PIL	Z-E2-PIL
PILASTER Z-E3-PIL	Z-E3-PIL	Z-E3-PIL
PILASTER Z-PIL-EXT	Z-PIL-EXT	Z-PIL-EXT
PLAIN PILASTER A3	PL7xxS	PIL7XxxP
PLAIN PILASTER B3	PL9xxS	PIL9XxxP
PLAIN PILASTER C3	PL11xxS	PIL11XxxP
PLINTH D1	PF10	ADD "P" TO END OF PILASTER
PLINTH D2	P14.5	N/A

LOUVERS			
Drees General Callout	Nuwood	Fypon	Mid-America
CATHEDRAL LOUVER D1	CLV1224	CLV12X24	--
CATHEDRAL LOUVER D1T	CLV1224TRIM4	CLV12X24X4F	--
CATHEDRAL LOUVER D2	CLV1432	CLV14X32	--
CATHEDRAL LOUVER D2T	CLV1432TRIM4	CLV14X32X4F	00 44 1422
CATHEDRAL LOUVER D3	CLV2232	CLV22X32	--
CATHEDRAL LOUVER D3T	CLV2232TRIM4	CLV22X32X4F	--
HALF CIRCLE LOUVER D1	HRLV32	HRLV32X16	--
HALF CIRCLE LOUVER D1T	HRLV32TRIM4	HRLV32X4F	--
HALF CIRCLE LOUVER D2	HRLV36	HRLV36X18	--
HALF CIRCLE LOUVER D2T	HRLV36TRIM4	HRLV36X4F	00 43 2234
OCTAGONAL LOUVER D1	OLV24	OLV24	--
OCTAGONAL LOUVER D12	OLV24TRIM4	OLV24X4F	--
OVAL LOUVER D1	OLV2537	OLV37X25	--
OVAL LOUVER D1T	OLV2537TRIM4	OLV37X25X4F	--
RECTANGULAR LOUVER D1	LV1224V	LV12X24	00 45 1218
RECTANGULAR LOUVER D1T	LV1224VTRIM4	LV12X24-4F	00 45 1218
RECTANGULAR LOUVER D2	LV1636V	LV16X36	--
RECTANGULAR LOUVER D2T	LV1636VTRIM4	LV16X36-4F	--
RECTANGULAR LOUVER D3	LV2436V	LV24X36	--
RECTANGULAR LOUVER D3T	LV2436VTRIM4	LV24X36-4F	--
RECTANGULAR LOUVER D4	LV2424V	LV24X24	--
RECTANGULAR LOUVER D4T	LV2424VTRIM4	LV24X24-4F	--
ROUND LOUVER D1	RLV18	RLV18	--
ROUND LOUVER D1T	RLV18TRIM4	RLV18X4F	--
ROUND LOUVER D2	RLV22	RLV22	--
ROUND LOUVER D2T	RLV22TRIM4	RLV22X4F	--
TRIANGULAR LOUVER D1	--	TRLVxxX36	00 47 0x0x

BRACKETS		
Drees General Callout	Nuwood	Fypon
EXTERIOR BRACKET D1	BR437	N/A
EXTERIOR BRACKET D2	DB102	DTLB6X4X6
EXTERIOR BRACKET D3	BR304 (7" WIDE)	BKT24X24X7
EXTERIOR BRACKET D4	BR455	N/A
EXTERIOR BRACKET D5	BR300-1	BKT12X12X6
EXTERIOR BRACKET D6	BR300	BKT12X12
EXTERIOR BRACKET D7	BR409	BKT16X18X3
EXTERIOR BRACKET D8	BR413	DTLB5X5X3
EXTERIOR BRACKET D9	TBD	BKT11X20
EXTERIOR BRACKET D10	TBD	BKT12X24X3
EXTERIOR BRACKET D11	BR435	BKT25X27
EXTERIOR BRACKET D12	BR404	BKT16X30X4
EXTERIOR BRACKET D13	BR23.13x10.13x5.5	N/A
GABLE BRACKET D1	TBD	DTLB6X4X6R(OR L)PITCH
GABLE BRACKET D2	BR423-x:12	BKT5X20
GABLE BRACKET D3	BR424-x:12	BKT5X20 (CUT 2" PROJECTION)

MOULDINGS		
Drees General Callout	Nuwood	Fypon
BAND MOULD D1	M210-16	MLD612-12
BAND MOULD D2	M301-16	MLD220-16
BARGE MOULD D1	WM210	WM210
CASE MOULD D1	M320-16	MLD226-16
CASE MOULD D2	N/A	MLD244-12
CROWN MOULD D1	M404-16	MLD572-16
DENTIL MOULD D1	M105-16	MLD310-16
DENTIL MOULD D2	M108-8	MLD353-8
HALF ROUND MOULD D1	N/A	MLD605-12
PANEL MOULD D1	M310-8 OR 16	MLD612-12

PEDIMENTS / COMBO HEADERS		
Drees General Callout	Nuwood	Fypon
BROW COMBO D1	BCxx	CSAPxx
PEAK PEDIMENT D1	Pxx-4 (6:12)	PCPxx
PEAK PEDIMENT Z-E1-PED	Z-E1-PED	Z-E1-PED
PEAKED COMBO D1	PCxx-4	CPCPxx
RAMS HEAD PEDIMENT D1	Rxx	RHPxx00
ROUND PEDIMENT D1	Bxx-4	PSPxx
SUNRISE COMBO D1	SCxx-4	CSPxx
VICTORIAN PEDIMENT D1	VPxx	DVPxx w/ SWDHxxXxx

WINDOW DECORATION		
Drees General Callout	Nuwood	Fypon
HALF CIRCLE SUNBURST D1	SPxxxx	SWDHxxXxx
PALLADIAN WINDOW D1	H9AR10-xx xx" FL/FR	ARxxX10MFLxxx
PALLADIAN WINDOW D1K	H9AR10-xxK xx" FL/FR	ARxxX10MFLxxx with K10TM
PALLADIAN WINDOW D2	H9AR10SPxxxx	ARxxX10MFLxxx with SWDHxxXxx
PALLADIAN WINDOW D2K	H9AR10SPxxxxK	ARxxX10MFLxxx with SWDHxxXxx and K10TM
PEAKED CAP HEADER D1	N/A	CHPCxxX15
PLAIN SEGMENT D1	SPxxxxP	PSPxx
SEGMENT SUNBURST D1	SPxxxx	SWDHxxXxx

ACCESSORIES		
Drees General Callout	Nuwood	Fypon
GABLE D1	PGDx12	GPA (width X height)
KEystone D1	KY14F-3	KY14
KEystone D2	KYHM9F	K9M
WREATH D1	N/A	WAB34



Copyright © 2008, (2017) The Drees Company. All Rights Reserved. No portion of this material may be reproduced in any form or by any means, including photocopying, without the express written permission of the Drees Company. The Drees Company will vigorously prosecute any unauthorized use of this material.

Sheet Description:

MOULDED MILLWORK SCHEDULE

Sheet No.

SC-02