

RE: J0323-1214
 Lot 43 Liberty Meadow

Trenco
 818 Soundside Rd
 Edenton, NC 27932

Site Information:

Customer: Project Name: J0323-1214
 Lot/Block: Model:
 Address: Subdivision:
 City: State:

General Truss Engineering Criteria & Design Loads (Individual Truss Design Drawings Show Special Loading Conditions):

Design Code: IRC2015/TPI2014 Design Program: MiTek 20/20 8.4
 Wind Code: ASCE 7-10 Wind Speed: 130 mph
 Roof Load: 40.0 psf Floor Load: N/A psf

This package includes 23 individual, dated Truss Design Drawings and 0 Additional Drawings.

No.	Seal#	Truss Name	Date	No.	Seal#	Truss Name	Date
1	I56917876	A1	3/1/2023	21	I56917896	V4	3/1/2023
2	I56917877	A1GE	3/1/2023	22	I56917897	V5	3/1/2023
3	I56917878	A2	3/1/2023	23	I56917898	V6	3/1/2023
4	I56917879	A3	3/1/2023				
5	I56917880	A3GE	3/1/2023				
6	I56917881	B1GE	3/1/2023				
7	I56917882	B2	3/1/2023				
8	I56917883	C1	3/1/2023				
9	I56917884	C1-GR	3/1/2023				
10	I56917885	C1GE	3/1/2023				
11	I56917886	G1	3/1/2023				
12	I56917887	G1GE	3/1/2023				
13	I56917888	J1	3/1/2023				
14	I56917889	J2	3/1/2023				
15	I56917890	J2GE	3/1/2023				
16	I56917891	J3	3/1/2023				
17	I56917892	J3GE	3/1/2023				
18	I56917893	V1	3/1/2023				
19	I56917894	V2	3/1/2023				
20	I56917895	V3	3/1/2023				

The truss drawing(s) referenced above have been prepared by Truss Engineering Co. under my direct supervision based on the parameters provided by Comtech, Inc - Fayetteville.
 Truss Design Engineer's Name: Gilbert, Eric
 My license renewal date for the state of North Carolina is December 31, 2023.
 North Carolina COA: C-0844

IMPORTANT NOTE: The seal on these truss component designs is a certification that the engineer named is licensed in the jurisdiction(s) identified and that the designs comply with ANSI/TPI 1. These designs are based upon parameters shown (e.g., loads, supports, dimensions, shapes and design codes), which were given to TRENCO. Any project specific information included is for TRENCO customers file reference purpose only, and was not taken into account in the preparation of these designs. TRENCO has not independently verified the applicability of the design parameters or the designs for any particular building. Before use, the building designer should verify applicability of design parameters and properly incorporate these designs into the overall building design per ANSI/TPI 1, Chapter 2.



March 01, 2023

Job J0323-1214	Truss A1	Truss Type COMMON	Qty 6	Ply 1	Lot 43 Liberty Meadow I56917876
-------------------	-------------	----------------------	----------	----------	------------------------------------

Comtech, Inc. Fayetteville, NC - 28314,

8.430 s Jan 6 2022 MiTek Industries, Inc. Wed Mar 1 09:54:40 2023 Page 1

ID:aTXuLo?nW09qtpROz2WQ0wydkZW-?BnmiPHT79Oqh0F54W?GM76zyEMuwtqpU7eeV9zfkAz

Job Reference (optional)

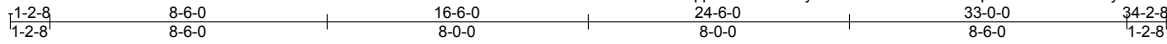

5x5 =

Scale = 1:70.6

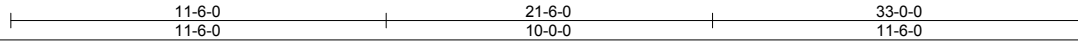
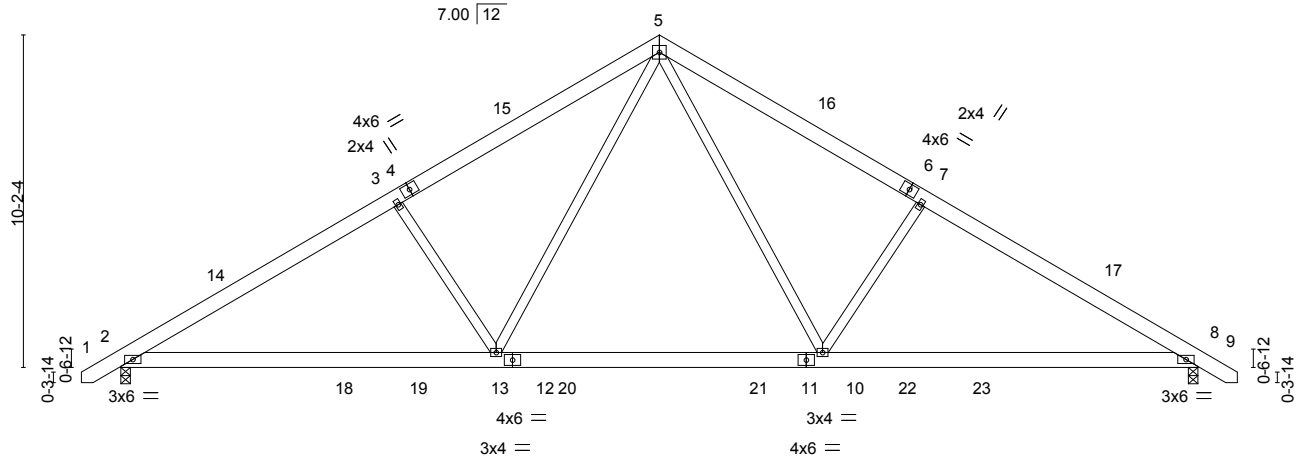

LOADING (psf)	SPACING-	2-0-0	CSI.	DEFL.	in (loc)	l/defl	L/d	PLATES	GRIP
TCLL 20.0	Plate Grip DOL	1.15	TC 0.30	Vert(LL)	-0.15 10-13	>999	360	MT20	244/190
BCDL 10.0	Lumber DOL	1.15	BC 0.53	Vert(CT)	-0.26 8-10	>999	240		
BCLL 0.0 *	Rep Stress Incr	YES	WB 0.31	Horz(CT)	0.05 8	n/a	n/a		
BCDL 10.0	Code IRC2015/TPI2014		Matrix-S	Wind(LL)	0.05 2-13	>999	240		
								Weight: 221 lb	FT = 20%

LUMBER-
TOP CHORD 2x6 SP No.1
BOT CHORD 2x6 SP No.1
WEBS 2x4 SP No.2

BRACING-
TOP CHORD Structural wood sheathing directly applied or 4-11-2 oc purlins.
BOT CHORD Rigid ceiling directly applied or 10-0-0 oc bracing.

REACTIONS. (size) 2=0-3-8, 8=0-3-8
Max Horz 2=245(LC 11)
Max Uplift 2=91(LC 12), 8=91(LC 13)
Max Grav 2=1525(LC 19), 8=1525(LC 20)

FORCES. (lb) - Max. Comp./Max. Ten. - All forces 250 (lb) or less except when shown.
TOP CHORD 2-3=-2295/423, 3-5=-2090/464, 5-7=-2091/464, 7-8=-2296/423
BOT CHORD 2-13=-222/2070, 10-13=-9/1347, 8-10=-233/1886
WEBS 3-13=-544/300, 5-13=-140/991, 5-10=-139/991, 7-10=-544/300

NOTES-

- Unbalanced roof live loads have been considered for this design.
- Wind: ASCE 7-10; Vult=130mph Vasd=103mph; TCCL=6.0psf; BCDL=6.0psf; h=15ft; Cat. II; Exp C; Enclosed; MWFRS (envelope) and C-C Exterior(2) -1-0-6 to 3-4-7, Interior(1) 3-4-7 to 16-6-0, Exterior(2) 16-6-0 to 20-10-13, Interior(1) 20-10-13 to 34-0-6 zone; C-C for members and forces & MWFRS for reactions shown; Lumber DOL=1.60 plate grip DOL=1.60
- This truss has been designed for a 10.0 psf bottom chord live load nonconcurrent with any other live loads.
- * This truss has been designed for a live load of 30.0psf on the bottom chord in all areas where a rectangle 3-6-0 tall by 2-0-0 wide will fit between the bottom chord and any other members, with BCDL = 10.0psf.
- Provide mechanical connection (by others) of truss to bearing plate capable of withstanding 91 lb uplift at joint 2 and 91 lb uplift at joint 8.

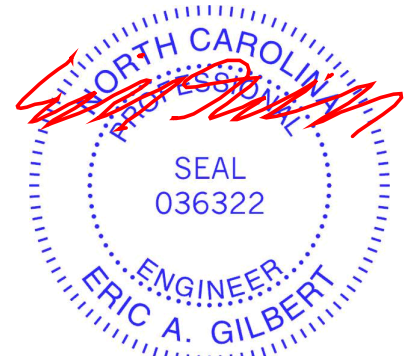

March 1, 2023

WARNING - Verify design parameters and READ NOTES ON THIS AND INCLUDED MITEK REFERENCE PAGE MII-7473 rev. 5/19/2020 BEFORE USE.

Design valid for use only with MiTek® connectors. This design is based only upon parameters shown, and is for an individual building component, not a truss system. Before use, the building designer must verify the applicability of design parameters and properly incorporate this design into the overall building design. Bracing indicated is to prevent buckling of individual truss web and/or chord members only. Additional temporary and permanent bracing is always required for stability and to prevent collapse with possible personal injury and property damage. For general guidance regarding the fabrication, storage, delivery, erection and bracing of trusses and truss systems, see

ANSI/TPI1 Quality Criteria, DSB-89 and BCSI Building Component

Safety Information available from Truss Plate Institute, 2670 Crain Highway, Suite 203 Waldorf, MD 20601



818 Soundside Road
Edenton, NC 27932

Job J0323-1214	Truss A1GE	Truss Type GABLE	Qty 1	Ply 1	Lot 43 Liberty Meadow Job Reference (optional)	I56917877
-------------------	---------------	---------------------	----------	----------	---	-----------

Comtech, Inc. Fayetteville, NC - 28314,

8.430 s Jan 6 2022 MiTek Industries, Inc. Wed Mar 1 09:54:43 2023 Page 1

ID:aTXuLo?nW09qtpROz2WQ0wydkZW-QmTvlQKMP4mPYU_gmfZz_mkYHSVZ7GJFA5t5UzfkAw



5x5 =

Scale = 1:67.2

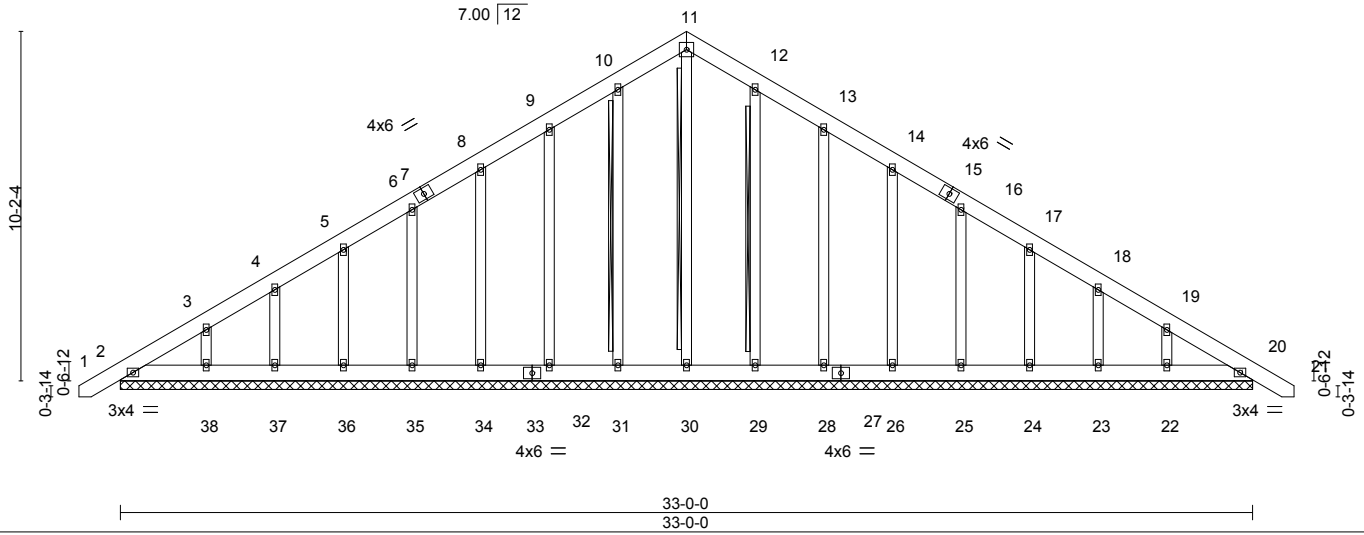

LOADING (psf)	SPACING-	2-0-0	CSI.	DEFL.	in (loc)	l/defl	L/d	PLATES	GRIP
TCLL 20.0	Plate Grip DOL	1.15	TC 0.04	Vert(LL)	-0.00	20	n/r	MT20	244/190
TCDL 10.0	Lumber DOL	1.15	BC 0.02	Vert(CT)	0.00	20	n/r		
BCLL 0.0 *	Rep Stress Incr	YES	WB 0.13	Horz(CT)	0.01	20	n/a		
BCDL 10.0	Code IRC2015/TPI2014		Matrix-S						
								Weight: 283 lb	FT = 20%

LUMBER-
TOP CHORD 2x6 SP No.1
BOT CHORD 2x6 SP No.1
OTHERS 2x4 SP No.2

BRACING-
TOP CHORD Structural wood sheathing directly applied or 6-0-0 oc purlins.
BOT CHORD Rigid ceiling directly applied or 10-0-0 oc bracing.
WEBS T-Brace: 2x4 SPF No.2 - 11-30, 10-31, 12-29
Fasten (2X) T and I braces to narrow edge of web with 10d (0.131"x3") nails, 6in o.c., with 3in minimum end distance.
Brace must cover 90% of web length.

REACTIONS. All bearings 33-0-0.
(lb) - Max Horz 2=306(LC 11)
Max Uplift All uplift 100 lb or less at joint(s) 2, 20, 31, 32, 34, 35, 36, 37, 38, 29, 28, 26, 25, 24, 23, 22
Max Grav All reactions 250 lb or less at joint(s) 2, 20, 30, 31, 32, 34, 35, 36, 37, 38, 29, 28, 26, 25, 24, 23, 22

FORCES. (lb) - Max. Comp./Max. Ten. - All forces 250 (lb) or less except when shown.
TOP CHORD 2-3=-277/226, 10-11=-242/277, 11-12=-242/277

- NOTES-**
- Unbalanced roof live loads have been considered for this design.
 - Wind: ASCE 7-10; Vult=130mph Vasd=103mph; TC DL=6.0psf; BCDL=6.0psf; h=15ft; Cat. II; Exp C; Enclosed; MWFRS (envelope) gable end zone and C-C Exterior(2) zone; C-C for members and forces & MWFRS for reactions shown; Lumber DOL=1.60 plate grip DOL=1.60
 - Truss designed for wind loads in the plane of the truss only. For studs exposed to wind (normal to the face), see Standard Industry Gable End Details as applicable, or consult qualified building designer as per ANSI/TPI 1.
 - All plates are 2x4 MT20 unless otherwise indicated.
 - Gable requires continuous bottom chord bearing.
 - Gable studs spaced at 2-0-0 oc.
 - This truss has been designed for a 10.0 psf bottom chord live load nonconcurrent with any other live loads.
 - * This truss has been designed for a live load of 30.0psf on the bottom chord in all areas where a rectangle 3-6-0 tall by 2-0-0 wide will fit between the bottom chord and any other members.
 - Provide mechanical connection (by others) of truss to bearing plate capable of withstanding 100 lb uplift at joint(s) 2, 20, 31, 32, 34, 35, 36, 37, 38, 29, 28, 26, 25, 24, 23, 22.
 - Warning: Additional permanent and stability bracing for truss system (not part of this component design) is always required.

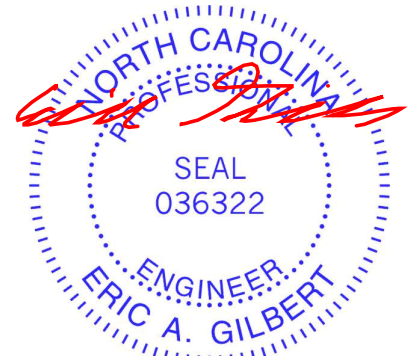

March 1, 2023

WARNING - Verify design parameters and READ NOTES ON THIS AND INCLUDED MITEK REFERENCE PAGE MII-7473 rev. 5/19/2020 BEFORE USE.

Design valid for use only with MiTek® connectors. This design is based only upon parameters shown, and is for an individual building component, not a truss system. Before use, the building designer must verify the applicability of design parameters and properly incorporate this design into the overall building design. Bracing indicated is to prevent buckling of individual truss web and/or chord members only. Additional temporary and permanent bracing is always required for stability and to prevent collapse with possible personal injury and property damage. For general guidance regarding the fabrication, storage, delivery, erection and bracing of trusses and truss systems, see

ANSI/TPI1 Quality Criteria, DSB-89 and BCSI Building Component

Safety Information available from Truss Plate Institute, 2670 Crain Highway, Suite 203 Waldorf, MD 20601



818 Soundside Road
Edenton, NC 27932

Job J0323-1214	Truss A2	Truss Type COMMON	Qty 4	Ply 1	Lot 43 Liberty Meadow I56917878
-------------------	-------------	----------------------	----------	----------	------------------------------------

Comtech, Inc. Fayetteville, NC - 28314,

8.430 s Jan 6 2022 MiTek Industries, Inc. Wed Mar 1 09:54:45 2023 Page 1

ID:aTXuLo?nW09qtpROz2WQ0wydkZW-M8af6Lcx16nn73t3bR3BqkLF2yb73YePMPAMzfKAU

Job Reference (optional)

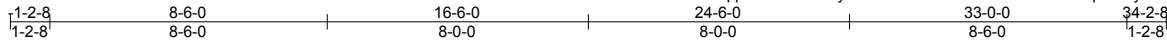

5x5 =

Scale = 1:70.6

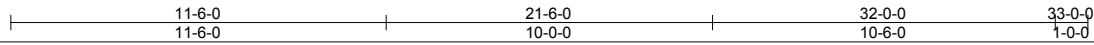
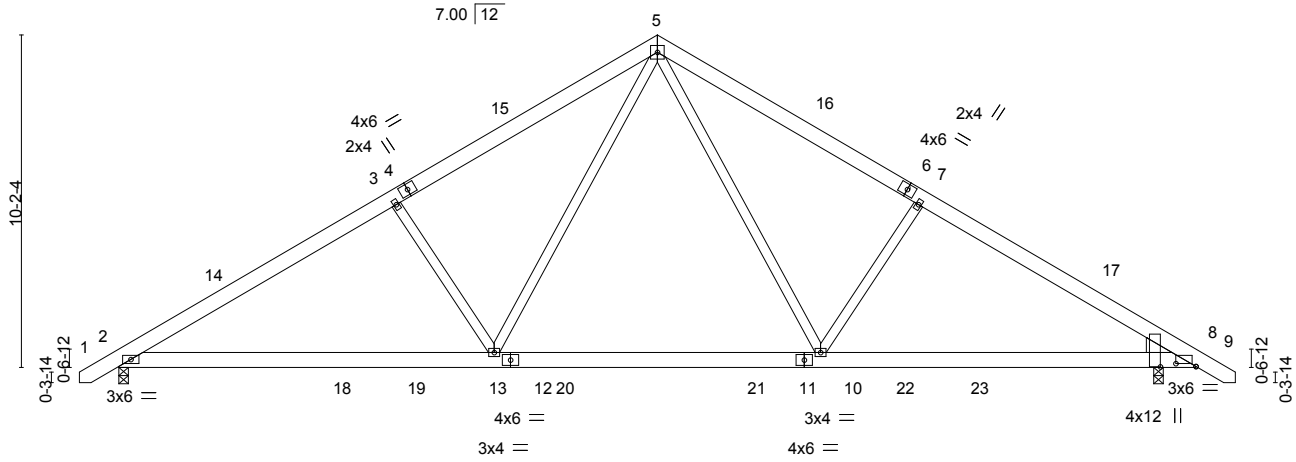

Plate Offsets (X,Y)-- [8:0-7-6,0-1-1], [8:0-0-2,1-1-1]

LOADING (psf)	SPACING-	CSI.	DEFL.	PLATES	GRIP
TCLL 20.0	2-0-0	TC 0.65	in (loc) l/defl L/d	MT20	244/190
TCDL 10.0	Plate Grip DOL 1.15	BC 0.60	Vert(LL) -0.15 10-13 >999 360		
BCLL 0.0 *	Lumber DOL 1.15	WB 0.31	Vert(CT) -0.26 8-10 >999 240		
BCDL 10.0	Rep Stress Incr YES	Matrix-S	Horz(CT) 0.05 8 n/a n/a		
	Code IRC2015/TPI2014		Wind(LL) 0.05 2-13 >999 240	Weight: 223 lb	FT = 20%

LUMBER-
 TOP CHORD 2x6 SP No.1
 BOT CHORD 2x6 SP No.1
 WEBS 2x4 SP No.2
 WEDGE
 Right: 2x6 SP No.1

BRACING-
 TOP CHORD Structural wood sheathing directly applied or 4-11-2 oc purlins.
 BOT CHORD Rigid ceiling directly applied or 10-0-0 oc bracing.

REACTIONS. (size) 2=0-3-8, 8=0-3-8
 Max Horz 2=245(LC 11)
 Max Uplift 2=-91(LC 12), 8=-91(LC 13)
 Max Grav 2=1525(LC 19), 8=1525(LC 20)

FORCES. (lb) - Max. Comp./Max. Ten. - All forces 250 (lb) or less except when shown.
 TOP CHORD 2-3=-2295/423, 3-5=-2090/464, 5-7=-2091/464, 7-8=-2296/423
 BOT CHORD 2-13=-222/2070, 10-13=-9/1347, 8-10=-233/1886
 WEBS 3-13=-544/300, 5-13=-140/991, 5-10=-139/991, 7-10=-544/300

NOTES-

- 1) Unbalanced roof live loads have been considered for this design.
- 2) Wind: ASCE 7-10; Vult=130mph Vasd=103mph; TCDL=6.0psf; BCDL=6.0psf; h=15ft; Cat. II; Exp C; Enclosed; MWFRS (envelope) and C-C Exterior(2) -1-0-6 to 3-4-7, Interior(1) 3-4-7 to 16-6-0, Exterior(2) 16-6-0 to 20-10-13, Interior(1) 20-10-13 to 34-0-6 zone; cantilever right exposed ;C-C for members and forces & MWFRS for reactions shown; Lumber DOL=1.60 plate grip DOL=1.60
- 3) This truss has been designed for a 10.0 psf bottom chord live load nonconcurrent with any other live loads.
- 4) * This truss has been designed for a live load of 30.0psf on the bottom chord in all areas where a rectangle 3-6-0 tall by 2-0-0 wide will fit between the bottom chord and any other members, with BCDL = 10.0psf.
- 5) Provide mechanical connection (by others) of truss to bearing plate capable of withstanding 100 lb uplift at joint(s) 2, 8.



March 1, 2023

Job J0323-1214	Truss A3	Truss Type COMMON	Qty 9	Ply 1	Lot 43 Liberty Meadow I56917879
-------------------	-------------	----------------------	----------	----------	------------------------------------

Comtech, Inc. Fayetteville, NC - 28314,

8.430 s Jan 6 2022 MiTek Industries, Inc. Wed Mar 1 09:54:46 2023 Page 1

ID:aTXuLo?nW09qtpROz2WQ0wydkZW-qL81zSMEI?9zPxiFRn6gcOM?DfP9KaDis35yipzfkAt



5x5 =

Scale = 1:69.1

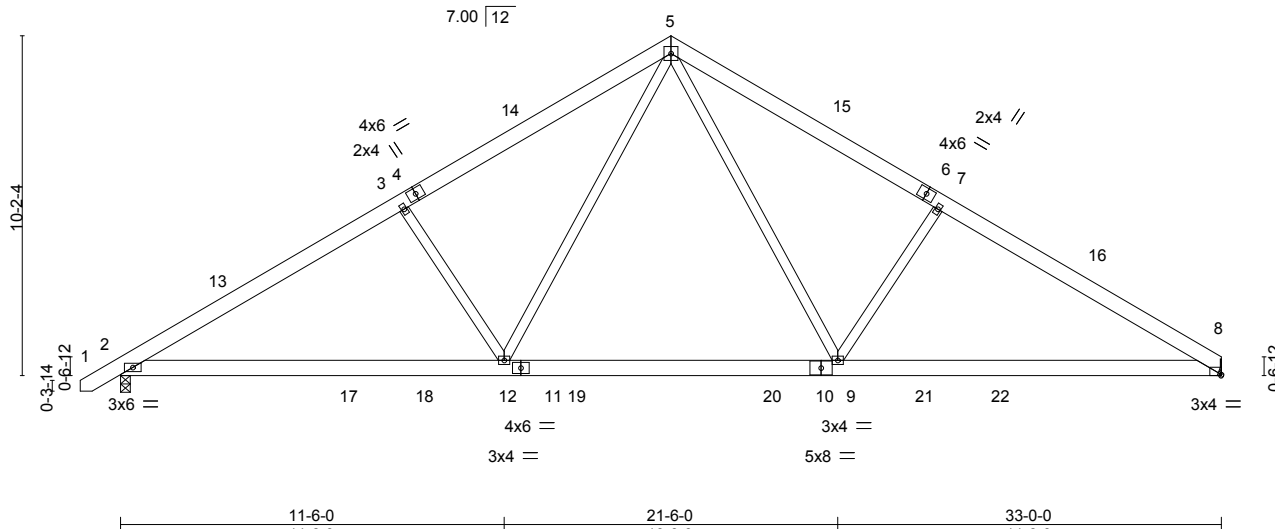

Plate Offsets (X,Y)--	[8:0-0-2,Edge]
-----------------------	----------------

LOADING (psf)	SPACING-	2-0-0	CSI.	DEFL.	in (loc)	l/defl	L/d	PLATES	GRIP
TCLL 20.0	Plate Grip DOL	1.15	TC 0.32	Vert(LL)	-0.15	9-12	>999	MT20	244/190
TCDL 10.0	Lumber DOL	1.15	BC 0.54	Vert(CT)	-0.27	8-9	>999		
BCLL 0.0 *	Rep Stress Incr	YES	WB 0.32	Horz(CT)	0.05	8	n/a		
BCDL 10.0	Code IRC2015/TPI2014		Matrix-S	Wind(LL)	0.05	2-12	>999		
								Weight: 218 lb	FT = 20%

LUMBER-	BRACING-
TOP CHORD 2x6 SP No.1	TOP CHORD Structural wood sheathing directly applied or 4-10-2 oc purlins.
BOT CHORD 2x6 SP No.1	BOT CHORD Rigid ceiling directly applied or 10-0-0 oc bracing.
WEBS 2x4 SP No.2	

REACTIONS. (size) 2=0-3-8, 8=Mechanical
 Max Horz 2=241(LC 11)
 Max Uplift 2=-91(LC 12), 8=-75(LC 13)
 Max Grav 2=1529(LC 19), 8=1461(LC 20)

FORCES. (lb) - Max. Comp./Max. Ten. - All forces 250 (lb) or less except when shown.
 TOP CHORD 2-3=-2303/425, 3-5=-2098/466, 5-7=-2112/480, 7-8=-2319/440
 BOT CHORD 2-12=-255/2070, 9-12=-30/1348, 8-9=-260/1916
 WEBS 3-12=-545/300, 5-12=-141/990, 5-9=-144/1011, 7-9=-555/308

- NOTES-**
- Unbalanced roof live loads have been considered for this design.
 - Wind: ASCE 7-10; Vult=130mph Vasd=103mph; TCDL=6.0psf; BCDL=6.0psf; h=15ft; Cat. II; Exp C; Enclosed; MWFRS (envelope) and C-C Exterior(2) -1-0-6 to 3-4-7, Interior(1) 3-4-7 to 16-6-0, Exterior(2) 16-6-0 to 20-10-13, Interior(1) 20-10-13 to 32-11-4 zone; C-C for members and forces & MWFRS for reactions shown; Lumber DOL=1.60 plate grip DOL=1.60
 - This truss has been designed for a 10.0 psf bottom chord live load nonconcurrent with any other live loads.
 - * This truss has been designed for a live load of 30.0psf on the bottom chord in all areas where a rectangle 3-6-0 tall by 2-0-0 wide will fit between the bottom chord and any other members, with BCDL = 10.0psf.
 - Refer to girder(s) for truss to truss connections.
 - Provide mechanical connection (by others) of truss to bearing plate capable of withstanding 100 lb uplift at joint(s) 2, 8.

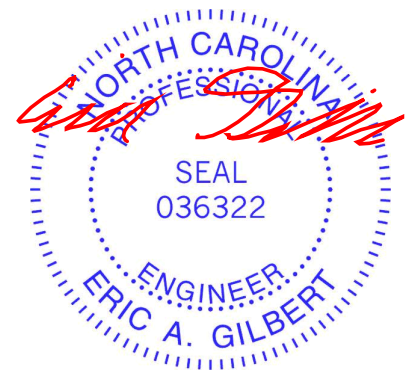

Job J0323-1214	Truss A3GE	Truss Type GABLE	Qty 1	Ply 1	Lot 43 Liberty Meadow I56917880
-------------------	---------------	---------------------	----------	----------	------------------------------------

Comtech, Inc. Fayetteville, NC - 28314,

8.430 s Jan 6 2022 MiTek Industries, Inc. Wed Mar 1 09:54:48 2023 Page 1

ID:aTXuLo?nW09qtpROz2WQ0wydkZW-mjGoO8OUEdPheFseYC98hpSP1TDjoWZ_KNa3nhzfKAR

Job Reference (optional)



5x5 =

Scale = 1:65.8

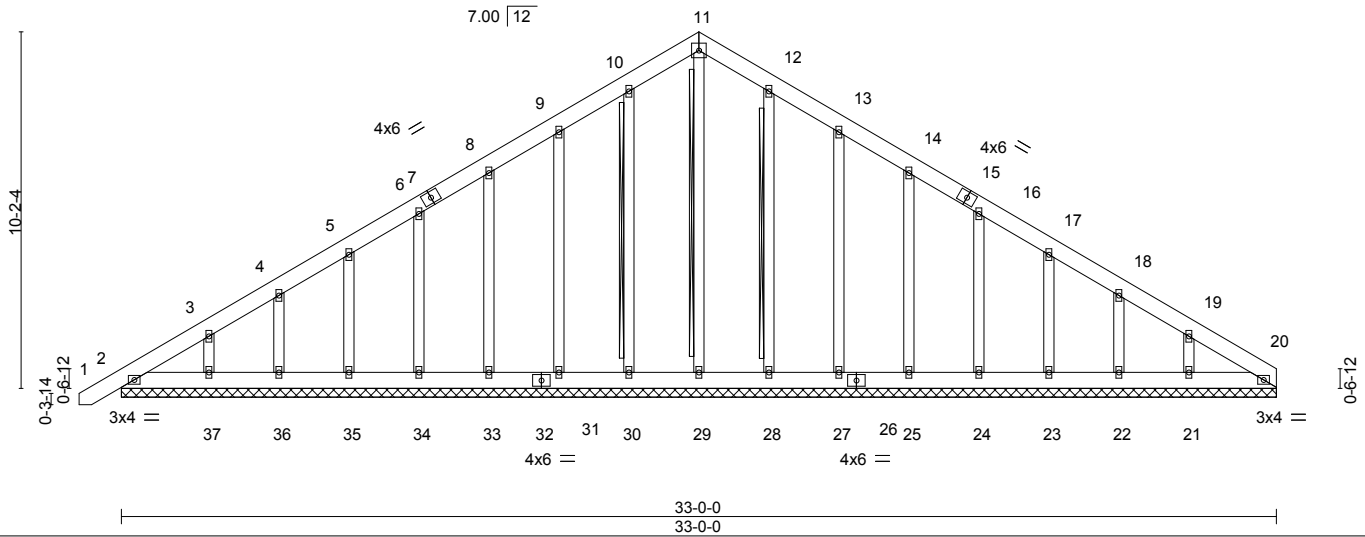

LOADING (psf)	SPACING-	2-0-0	CSI.	DEFL.	in (loc)	l/defl	L/d	PLATES	GRIP
TCLL 20.0	Plate Grip DOL	1.15	TC 0.04	Vert(LL)	-0.00	1	n/r	MT20	244/190
TCDL 10.0	Lumber DOL	1.15	BC 0.02	Vert(CT)	0.00	1	n/r		
BCLL 0.0 *	Rep Stress Incr	YES	WB 0.13	Horz(CT)	0.01	20	n/a		
BCDL 10.0	Code IRC2015/TPI2014		Matrix-S					Weight: 280 lb	FT = 20%

LUMBER-
 TOP CHORD 2x6 SP No.1
 BOT CHORD 2x6 SP No.1
 OTHERS 2x4 SP No.2

BRACING-
 TOP CHORD Structural wood sheathing directly applied or 6-0-0 oc purlins.
 BOT CHORD Rigid ceiling directly applied or 10-0-0 oc bracing.
 WEBS T-Brace: 2x4 SPF No.2 - 11-29, 10-30, 12-28
 Fasten (2X) T and I braces to narrow edge of web with 10d (0.131"x3") nails, 6in o.c., with 3in minimum end distance.
 Brace must cover 90% of web length.

REACTIONS. All bearings 33-0-0.
 (lb) - Max Horz 2=301(LC 9)
 Max Uplift All uplift 100 lb or less at joint(s) 2, 20, 30, 31, 33, 34, 35, 36, 37, 28, 27, 25, 24, 23, 22 except 21=-107(LC 13)
 Max Grav All reactions 250 lb or less at joint(s) 2, 20, 29, 30, 31, 33, 34, 35, 36, 37, 28, 27, 25, 24, 23, 22, 21

FORCES. (lb) - Max. Comp./Max. Ten. - All forces 250 (lb) or less except when shown.
 TOP CHORD 2-3=-280/222, 10-11=-236/265, 11-12=-236/265

- NOTES-**
- 1) Unbalanced roof live loads have been considered for this design.
 - 2) Wind: ASCE 7-10; Vult=130mph Vasd=103mph; TCDL=6.0psf; BCDL=6.0psf; h=15ft; Cat. II; Exp C; Enclosed; MWFRS (envelope) gable end zone and C-C Exterior(2) zone; C-C for members and forces & MWFRS for reactions shown; Lumber DOL=1.60 plate grip DOL=1.60
 - 3) Truss designed for wind loads in the plane of the truss only. For studs exposed to wind (normal to the face), see Standard Industry Gable End Details as applicable, or consult qualified building designer as per ANSI/TPI 1.
 - 4) All plates are 2x4 MT20 unless otherwise indicated.
 - 5) Gable requires continuous bottom chord bearing.
 - 6) Gable studs spaced at 2-0-0 oc.
 - 7) This truss has been designed for a 10.0 psf bottom chord live load nonconcurrent with any other live loads.
 - 8) * This truss has been designed for a live load of 30.0psf on the bottom chord in all areas where a rectangle 3-6-0 tall by 2-0-0 wide will fit between the bottom chord and any other members.
 - 9) Provide mechanical connection (by others) of truss to bearing plate capable of withstanding 100 lb uplift at joint(s) 2, 20, 30, 31, 33, 34, 35, 36, 37, 28, 27, 25, 24, 23, 22 except (jt=lb) 21=107.
 - 10) Warning: Additional permanent and stability bracing for truss system (not part of this component design) is always required.

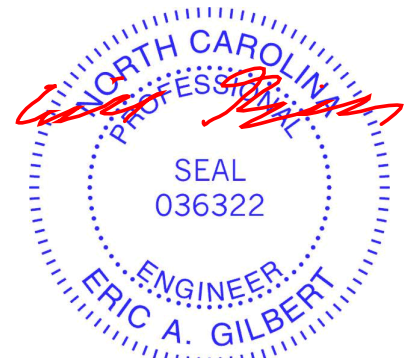

March 1, 2023

WARNING - Verify design parameters and READ NOTES ON THIS AND INCLUDED MITEK REFERENCE PAGE MII-7473 rev. 5/19/2020 BEFORE USE.

Design valid for use only with MiTek® connectors. This design is based only upon parameters shown, and is for an individual building component, not a truss system. Before use, the building designer must verify the applicability of design parameters and properly incorporate this design into the overall building design. Bracing indicated is to prevent buckling of individual truss web and/or chord members only. Additional temporary and permanent bracing is always required for stability and to prevent collapse with possible personal injury and property damage. For general guidance regarding the fabrication, storage, delivery, erection and bracing of trusses and truss systems, see

ANSI/TPI1 Quality Criteria, DSB-89 and BCSI Building Component

Safety Information available from Truss Plate Institute, 2670 Crain Highway, Suite 203 Waldorf, MD 20601



818 Soundside Road
 Edenton, NC 27932

Job J0323-1214	Truss B1GE	Truss Type GABLE	Qty 1	Ply 1	Lot 43 Liberty Meadow I56917881
Comtech, Inc. Fayetteville, NC - 28314,					Job Reference (optional)

8.430 s Jan 6 2022 MiTek Industries, Inc. Wed Mar 1 09:54:50 2023 Page 1
 ID:aTXuLo?nW09qtpROz2WQ0wydkZW-j6OYpqPlmEfPuZ00gdBcmEXj_GsaGRmHng3ArazfkAp

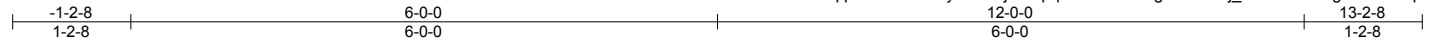

Scale = 1:23.6

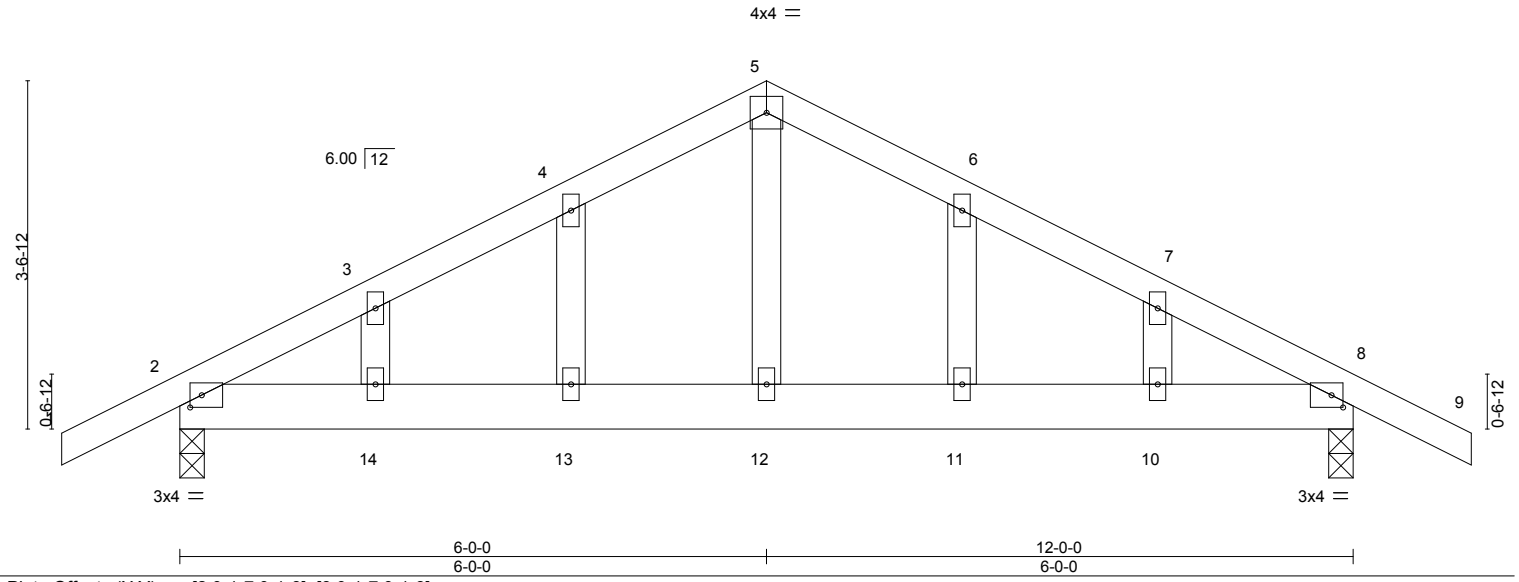

LOADING (psf)	SPACING-	CSI.	DEFL.	PLATES	GRIP
TCLL 20.0	2-0-0	TC 0.14	in (loc) l/defl L/d	MT20	244/190
TCDL 10.0	Plate Grip DOL 1.15	BC 0.19	Vert(LL) -0.02 10-11 >999 360		
BCLL 0.0 *	Lumber DOL 1.15	WB 0.09	Vert(CT) -0.03 10-11 >999 240		
BCDL 10.0	Rep Stress Incr YES	Matrix-S	Horz(CT) 0.01 8 n/a n/a		
	Code IRC2015/TPI2014		Wind(LL) 0.03 10-11 >999 240	Weight: 65 lb	FT = 20%

LUMBER-	BRACING-
TOP CHORD 2x4 SP No.1	TOP CHORD Structural wood sheathing directly applied or 6-0-0 oc purlins.
BOT CHORD 2x6 SP No.1	BOT CHORD Rigid ceiling directly applied or 10-0-0 oc bracing.
WEBS 2x4 SP No.2	
OTHERS 2x4 SP No.2	

REACTIONS. (size) 2=0-3-0, 8=0-3-0
 Max Horz 2=-73(LC 17)
 Max Uplift 2=-143(LC 9), 8=-143(LC 8)
 Max Grav 2=550(LC 1), 8=550(LC 1)

FORCES. (lb) - Max. Comp./Max. Ten. - All forces 250 (lb) or less except when shown.
 TOP CHORD 2-3=-617/666, 3-4=-570/687, 4-5=-561/740, 5-6=-561/740, 6-7=-570/688, 7-8=-617/666
 BOT CHORD 2-14=-494/491, 13-14=-494/491, 12-13=-494/491, 11-12=-494/491, 10-11=-494/491,
 8-10=-494/491
 WEBS 5-12=-513/328

- NOTES-**
- 1) Unbalanced roof live loads have been considered for this design.
 - 2) Wind: ASCE 7-10; Vult=130mph Vasd=103mph; TCDL=6.0psf; BCDL=6.0psf; h=15ft; Cat. II; Exp C; Enclosed; MWFRS (envelope) gable end zone and C-C Exterior(2) zone; porch left and right exposed; C-C for members and forces & MWFRS for reactions shown; Lumber DOL=1.60 plate grip DOL=1.60
 - 3) Truss designed for wind loads in the plane of the truss only. For studs exposed to wind (normal to the face), see Standard Industry Gable End Details as applicable, or consult qualified building designer as per ANSI/TPI 1.
 - 4) All plates are 2x4 MT20 unless otherwise indicated.
 - 5) Gable studs spaced at 2-0-0 oc.
 - 6) This truss has been designed for a 10.0 psf bottom chord live load nonconcurrent with any other live loads.
 - 7) * This truss has been designed for a live load of 30.0psf on the bottom chord in all areas where a rectangle 3-6-0 tall by 2-0-0 wide will fit between the bottom chord and any other members.
 - 8) Provide mechanical connection (by others) of truss to bearing plate capable of withstanding 100 lb uplift at joint(s) except (jt=lb) 2=143, 8=143.

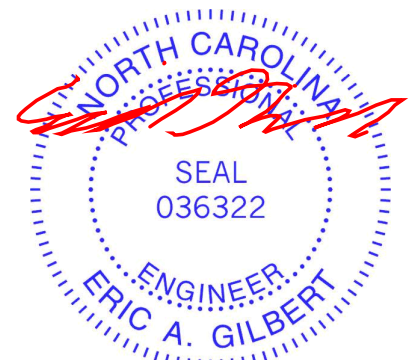

March 1, 2023

Job J0323-1214	Truss B2	Truss Type COMMON	Qty 4	Ply 1	Lot 43 Liberty Meadow I56917882
Comtech, Inc. Fayetteville, NC - 28314,					Job Reference (optional)

8.430 s Jan 6 2022 MiTek Industries, Inc. Wed Mar 1 09:54:51 2023 Page 1
 ID:aTXuLo?nW09qtpROz2WQ0wydkZW-Blxw09QNXYnGVibDEKirJS4rMgCN?uKR0KpiN0zfKAO



Scale = 1:23.7

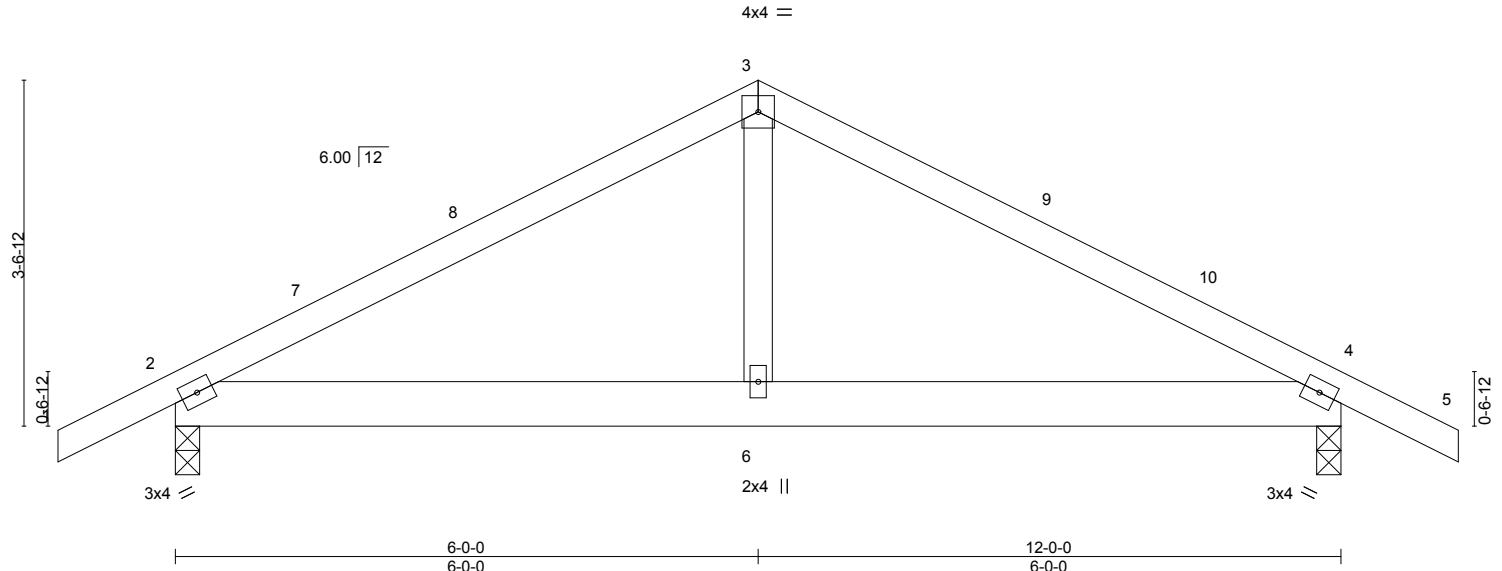

LOADING (psf)	SPACING-	CSI.	DEFL.	in (loc)	l/defl	L/d	PLATES	GRIP
TCLL 20.0	2-0-0	TC 0.29	Vert(LL)	-0.01	4-6	>999	MT20	244/190
TCDL 10.0	Plate Grip DOL 1.15	BC 0.15	Vert(CT)	-0.02	4-6	>999		
BCLL 0.0 *	Lumber DOL 1.15	WB 0.07	Horz(CT)	0.01	4	n/a		
BCDL 10.0	Rep Stress Incr YES	Matrix-S	Wind(LL)	0.03	4-6	>999		
	Code IRC2015/TPI2014						Weight: 57 lb	FT = 20%

LUMBER-	BRACING-
TOP CHORD 2x4 SP No.1	TOP CHORD Structural wood sheathing directly applied or 6-0-0 oc purlins.
BOT CHORD 2x6 SP No.1	BOT CHORD Rigid ceiling directly applied or 10-0-0 oc bracing.
WEBS 2x4 SP No.2	

REACTIONS. (size) 2=0-3-0, 4=0-3-0
 Max Horz 2=-47(LC 10)
 Max Uplift 2=-109(LC 9), 4=-109(LC 8)
 Max Grav 2=550(LC 1), 4=550(LC 1)

FORCES. (lb) - Max. Comp./Max. Ten. - All forces 250 (lb) or less except when shown.
 TOP CHORD 2-3=-640/667, 3-4=-640/667
 BOT CHORD 2-6=-457/485, 4-6=-457/485
 WEBS 3-6=-394/296

- NOTES-**
- 1) Unbalanced roof live loads have been considered for this design.
 - 2) Wind: ASCE 7-10; Vult=130mph Vasd=103mph; TCCL=6.0psf; BCDL=6.0psf; h=15ft; Cat. II; Exp C; Enclosed; MWFRS (envelope) and C-C Exterior(2) -1-2-8 to 3-2-5, Interior(1) 3-2-5 to 6-0-0, Exterior(2) 6-0-0 to 10-4-13, Interior(1) 10-4-13 to 13-2-8 zone; porch left and right exposed; C-C for members and forces & MWFRS for reactions shown; Lumber DOL=1.60 plate grip DOL=1.60
 - 3) This truss has been designed for a 10.0 psf bottom chord live load nonconcurrent with any other live loads.
 - 4) * This truss has been designed for a live load of 30.0psf on the bottom chord in all areas where a rectangle 3-6-0 tall by 2-0-0 wide will fit between the bottom chord and any other members.
 - 5) Provide mechanical connection (by others) of truss to bearing plate capable of withstanding 100 lb uplift at joint(s) except (jt=lb) 2=109, 4=109.

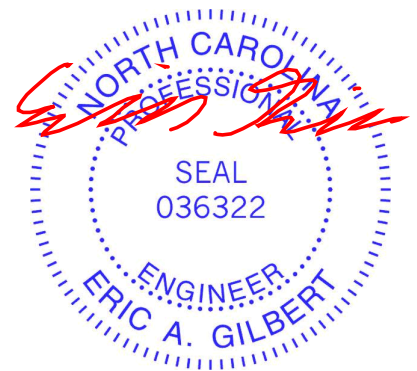

Job J0323-1214	Truss C1	Truss Type COMMON	Qty 5	Ply 1	Lot 43 Liberty Meadow I56917883
-------------------	-------------	----------------------	----------	----------	------------------------------------

Comtech, Inc. Fayetteville, NC - 28314,

8.430 s Jan 6 2022 MiTek Industries, Inc. Wed Mar 1 09:54:52 2023 Page 1

ID:aTXuLo?nW09qtpROz2WQ0wydkZW-fVVJDVVR?Irv77sAPn2D4rfcz_4SakKkaF_YHwSzfKAn

Job Reference (optional)

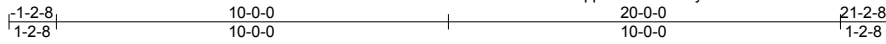

5x8 ||

Scale = 1:58.8

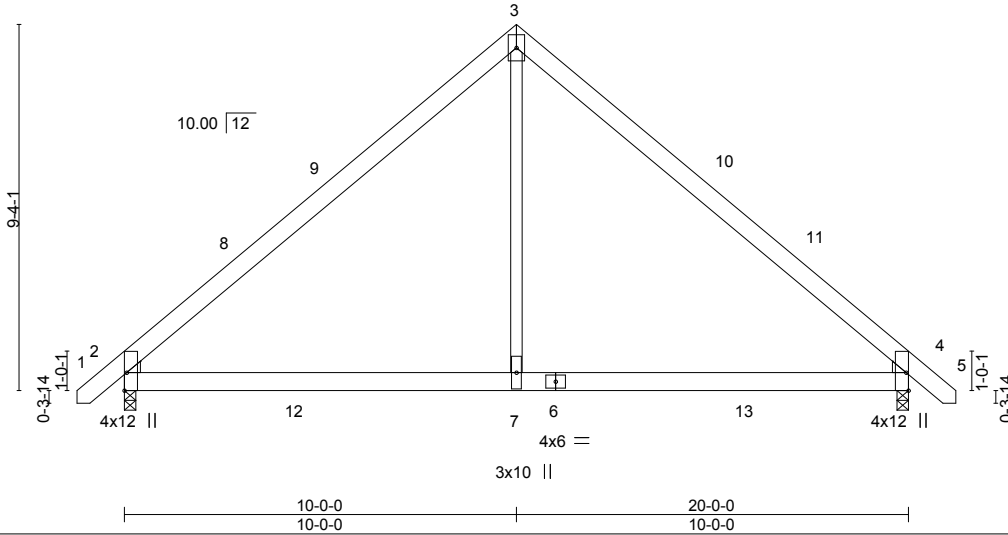

Plate Offsets (X,Y)--	[2:Edge,0-0-11], [4:Edge,0-0-11]
-----------------------	----------------------------------

LOADING (psf)	SPACING-	CSI.	DEFL.	PLATES	GRIP
TCLL 20.0	2-0-0	TC 0.49	in (loc) l/defl L/d	MT20	244/190
TCDL 10.0	Plate Grip DOL 1.15	BC 0.54	Vert(LL) -0.10 4-7 >999 360		
BCLL 0.0 *	Lumber DOL 1.15	WB 0.19	Vert(CT) -0.17 4-7 >999 240		
BCDL 10.0	Rep Stress Incr YES	Matrix-S	Horz(CT) 0.01 4 n/a n/a		
	Code IRC2015/TPI2014		Wind(LL) 0.06 2-7 >999 240	Weight: 129 lb	FT = 20%

LUMBER-	BRACING-
TOP CHORD 2x6 SP No.1	TOP CHORD Structural wood sheathing directly applied or 6-0-0 oc purlins.
BOT CHORD 2x6 SP No.1	BOT CHORD Rigid ceiling directly applied or 10-0-0 oc bracing.
WEBS 2x4 SP No.2	
WEDGE	
Left: 2x4 SP No.3 , Right: 2x4 SP No.3	

REACTIONS. (size) 4=0-3-8, 2=0-3-8
 Max Horz 2=-221(LC 10)
 Max Uplift 4=-48(LC 13), 2=-48(LC 12)
 Max Grav 4=1044(LC 20), 2=1044(LC 19)

FORCES. (lb) - Max. Comp./Max. Ten. - All forces 250 (lb) or less except when shown.
 TOP CHORD 2-3=-1118/210, 3-4=-1118/210
 BOT CHORD 2-7=0/784, 4-7=0/784
 WEBS 3-7=0/822

- NOTES-**
- 1) Unbalanced roof live loads have been considered for this design.
 - 2) Wind: ASCE 7-10; Vult=130mph Vasd=103mph; TCDL=6.0psf; BCDL=6.0psf; h=15ft; Cat. II; Exp C; Enclosed; MWFRS (envelope) and C-C Exterior(2) -1-0-8 to 3-4-4, Interior(1) 3-4-4 to 10-0-0, Exterior(2) 10-0-0 to 14-4-13, Interior(1) 14-4-13 to 21-0-8 zone; C-C for members and forces & MWFRS for reactions shown; Lumber DOL=1.60 plate grip DOL=1.60
 - 3) This truss has been designed for a 10.0 psf bottom chord live load nonconcurrent with any other live loads.
 - 4) * This truss has been designed for a live load of 30.0psf on the bottom chord in all areas where a rectangle 3-6-0 tall by 2-0-0 wide will fit between the bottom chord and any other members, with BCDL = 10.0psf.
 - 5) Provide mechanical connection (by others) of truss to bearing plate capable of withstanding 100 lb uplift at joint(s) 4, 2.

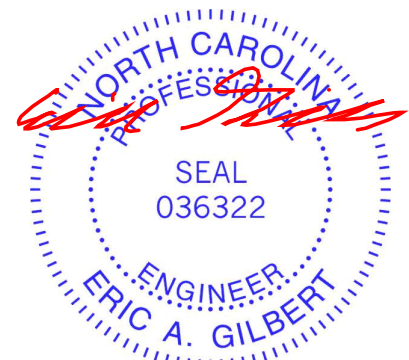

March 1, 2023

Job J0323-1214	Truss C1-GR	Truss Type COMMON GIRDER	Qty 1	Ply 2	Lot 43 Liberty Meadow I56917884
-------------------	----------------	-----------------------------	----------	----------	------------------------------------

Comtech, Inc. Fayetteville, NC - 28314,

8.430 s Jan 6 2022 MiTek Industries, Inc. Wed Mar 1 09:54:56 2023 Page 1

ID:aTXuLo?nW099qtpROz2WQ0wydkZW-XGlp3tUVM4PYcUTA0tI00Vnd5hqqgzOA9cWU3DzfkAJ



5x8 ||

Scale = 1:58.8

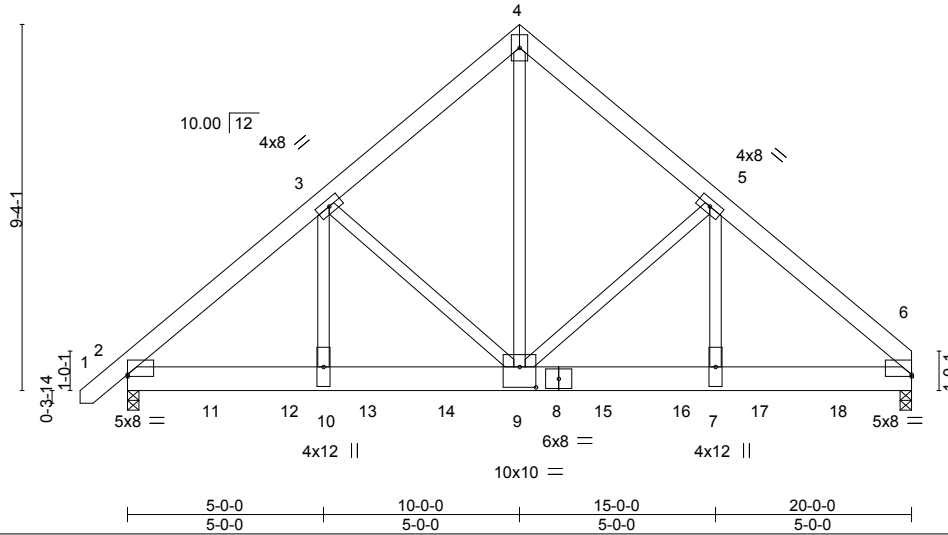

Plate Offsets (X,Y)-- [2:0-0-0,0-0-9], [6:Edge,0-0-9], [9:0-5-0,0-6-4]

LOADING (psf)	SPACING-	CSI.	DEFL.	PLATES	GRIP
TCLL 20.0	2-0-0	TC 0.61	in (loc) l/defl L/d	MT20	244/190
TCDL 10.0	Plate Grip DOL 1.15	BC 0.45	Vert(LL) -0.07 9-10 >999 360		
BCLL 0.0 *	Lumber DOL 1.15	WB 0.85	Vert(CT) -0.13 9-10 >999 240		
BCDL 10.0	Rep Stress Incr NO	Matrix-S	Horz(CT) 0.03 6 n/a n/a		
	Code IRC2015/TPI2014		Wind(LL) 0.05 9-10 >999 240	Weight: 341 lb	FT = 20%

LUMBER-
 TOP CHORD 2x6 SP No.1
 BOT CHORD 2x8 SP 2400F 2.0E
 WEBS 2x4 SP No.2

BRACING-
 TOP CHORD Structural wood sheathing directly applied or 5-7-9 oc purlins.
 BOT CHORD Rigid ceiling directly applied or 10-0-0 oc bracing.

REACTIONS. (size) 6=0-3-8, 2=0-3-8
 Max Horz 2=217(LC 26)
 Max Uplift 6=-424(LC 9), 2=-437(LC 8)
 Max Grav 6=6844(LC 2), 2=6838(LC 2)

FORCES. (lb) - Max. Comp./Max. Ten. - All forces 250 (lb) or less except when shown.
 TOP CHORD 2-3=-8399/550, 3-4=-5693/462, 4-5=-5691/461, 5-6=-8413/547
 BOT CHORD 2-10=-410/6080, 9-10=-410/6081, 7-9=-340/6084, 6-7=-340/6083
 WEBS 4-9=-485/6901, 5-9=-2367/286, 5-7=-162/3485, 3-9=-2363/282, 3-10=-164/3461

- NOTES-**
- 2-ply truss to be connected together with 10d (0.131"x3") nails as follows:
 Top chords connected as follows: 2x6 - 2 rows staggered at 0-9-0 oc.
 Bottom chords connected as follows: 2x8 - 2 rows staggered at 0-7-0 oc.
 Webs connected as follows: 2x4 - 1 row at 0-9-0 oc.
 - All loads are considered equally applied to all plies, except if noted as front (F) or back (B) face in the LOAD CASE(S) section. Ply to ply connections have been provided to distribute only loads noted as (F) or (B), unless otherwise indicated.
 - Unbalanced roof live loads have been considered for this design.
 - Wind: ASCE 7-10; Vult=130mph Vasd=103mph; TCDL=6.0psf; BCDL=6.0psf; h=15ft; Cat. II; Exp C; Enclosed; MWFRS (envelope); Lumber DOL=1.60 plate grip DOL=1.60
 - This truss has been designed for a 10.0 psf bottom chord live load nonconcurrent with any other live loads.
 - * This truss has been designed for a live load of 30.0psf on the bottom chord in all areas where a rectangle 3-6-0 tall by 2-0-0 wide will fit between the bottom chord and any other members.
 - Provide mechanical connection (by others) of truss to bearing plate capable of withstanding 100 lb uplift at joint(s) except (jt=lb) 6=424, 2=437.
 - Hanger(s) or other connection device(s) shall be provided sufficient to support concentrated load(s) 1360 lb down and 95 lb up at 2-0-12, 1360 lb down and 95 lb up at 4-0-12, 1360 lb down and 95 lb up at 6-0-12, 1360 lb down and 95 lb up at 8-0-12, 1360 lb down and 95 lb up at 10-0-12, 1360 lb down and 95 lb up at 12-0-12, 1360 lb down and 95 lb up at 14-0-12, and 1360 lb down and 95 lb up at 16-0-12, and 1360 lb down and 95 lb up at 18-0-12 on bottom chord. The design/selection of such connection device(s) is the responsibility of others.

LOAD CASE(S) Standard
 1) Dead + Roof Live (balanced): Lumber Increase=1.15, Plate Increase=1.15
 Uniform Loads (plf)
 Vert: 1-4=-60, 4-6=-60, 2-6=-20



March 1, 2023

Continued on page 2

WARNING - Verify design parameters and READ NOTES ON THIS AND INCLUDED MITEK REFERENCE PAGE MII-7473 rev. 5/19/2020 BEFORE USE.
 Design valid for use only with MiTek® connectors. This design is based only upon parameters shown, and is for an individual building component, not a truss system. Before use, the building designer must verify the applicability of design parameters and properly incorporate this design into the overall building design. Bracing indicated is to prevent buckling of individual truss web and/or chord members only. Additional temporary and permanent bracing is always required for stability and to prevent collapse with possible personal injury and property damage. For general guidance regarding the fabrication, storage, delivery, erection and bracing of trusses and truss systems, see **ANSI/TPI1 Quality Criteria, DSB-89 and BCSI Building Component Safety Information** available from Truss Plate Institute, 2670 Crain Highway, Suite 203 Waldorf, MD 20601

ENGINEERING BY
TRENCO
 A MiTek Affiliate
 818 Soundside Road
 Edenton, NC 27932

Job J0323-1214	Truss C1-GR	Truss Type COMMON GIRDER	Qty 1	Ply 2	Lot 43 Liberty Meadow I56917884
-------------------	----------------	-----------------------------	----------	-----------------	------------------------------------

Comtech, Inc. Fayetteville, NC - 28314,

8.430 s Jan 6 2022 MiTek Industries, Inc. Wed Mar 1 09:54:56 2023 Page 2
ID:aTXuLo?nW09qtpROz2WQ0wydkZW-XGlp3tUVM4PYcUTA0tI00Vnd5hqqgzOA9cWU3DzfKAj

Job Reference (optional)

LOAD CASE(S) Standard

Concentrated Loads (lb)

Vert: 9=-1290(F) 11=-1290(F) 12=-1290(F) 13=-1290(F) 14=-1290(F) 15=-1290(F) 16=-1290(F) 17=-1290(F) 18=-1290(F)

WARNING - Verify design parameters and READ NOTES ON THIS AND INCLUDED MITEK REFERENCE PAGE MII-7473 rev. 5/19/2020 BEFORE USE.

Design valid for use only with MiTek® connectors. This design is based only upon parameters shown, and is for an individual building component, not a truss system. Before use, the building designer must verify the applicability of design parameters and properly incorporate this design into the overall building design. Bracing indicated is to prevent buckling of individual truss web and/or chord members only. Additional temporary and permanent bracing is always required for stability and to prevent collapse with possible personal injury and property damage. For general guidance regarding the fabrication, storage, delivery, erection and bracing of trusses and truss systems, see **ANSI/TPI1 Quality Criteria, DSB-89 and BCSI Building Component Safety Information** available from Truss Plate Institute, 2670 Crain Highway, Suite 203 Waldorf, MD 20601



818 Soundside Road
Edenton, NC 27932

Job J0323-1214	Truss C1GE	Truss Type GABLE	Qty 1	Ply 1	Lot 43 Liberty Meadow I56917885
-------------------	---------------	---------------------	----------	----------	------------------------------------

Comtech, Inc. Fayetteville, NC - 28314,

8.430 s Jan 6 2022 MiTek Industries, Inc. Wed Mar 1 09:54:54 2023 Page 1

ID:aTXuLo7nW09qtpROz2WQ0wydkZW-btd3eBSFqT9rMAJovSFYx4hN?tAECAttil1O_LzfKA1

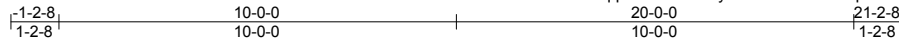

5x8 ||

Scale = 1:58.0

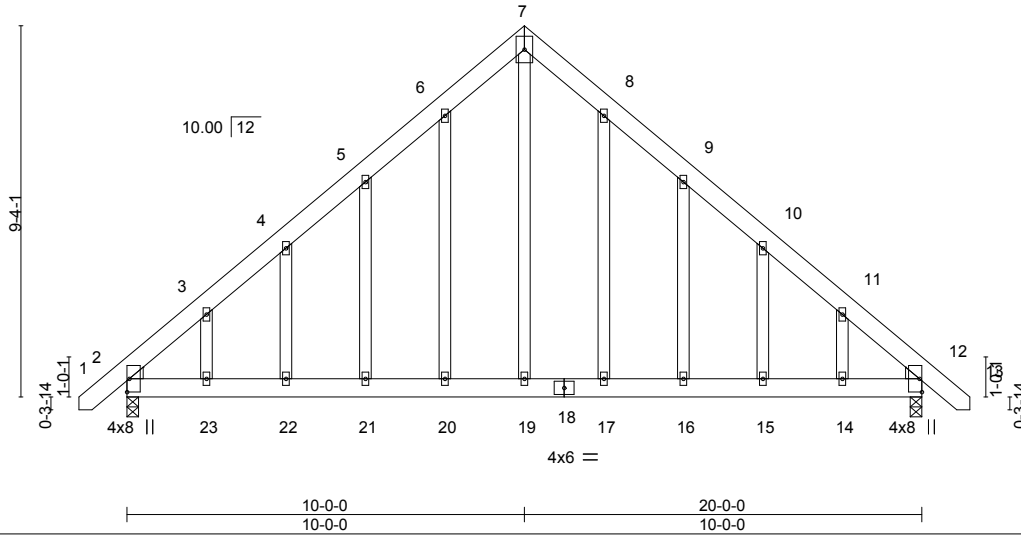

LOADING (psf)	SPACING-	CSI.	DEFL.	in (loc)	l/defl	L/d	PLATES	GRIP
TCLL 20.0	2-0-0	TC 0.20	Vert(LL)	-0.09 15-16	>999	360	MT20	244/190
TCDL 10.0	Plate Grip DOL 1.15	BC 0.40	Vert(CT)	-0.14 15-16	>999	240		
BCLL 0.0 *	Lumber DOL 1.15	WB 0.40	Horz(CT)	0.01 12	n/a	n/a		
BCDL 10.0	Rep Stress Incr YES	Matrix-S	Wind(LL)	0.15 21-22	>999	240		
	Code IRC2015/TPI2014						Weight: 180 lb	FT = 20%

LUMBER-

TOP CHORD 2x6 SP No.1
 BOT CHORD 2x6 SP No.1
 WEBS 2x4 SP No.2
 OTHERS 2x4 SP No.2
 WEDGE

Left: 2x4 SP No.3 , Right: 2x4 SP No.3

BRACING-

TOP CHORD Structural wood sheathing directly applied or 6-0-0 oc purlins.
 BOT CHORD Rigid ceiling directly applied or 10-0-0 oc bracing.

REACTIONS.

(size) 12=0-3-8, 2=0-3-8
 Max Horz 2=-276(LC 10)
 Max Uplift 12=-169(LC 13), 2=-169(LC 12)
 Max Grav 12=860(LC 1), 2=860(LC 1)

FORCES. (lb) - Max. Comp./Max. Ten. - All forces 250 (lb) or less except when shown.

TOP CHORD 2-3=-870/130, 3-4=-749/172, 4-5=-705/231, 5-6=-739/304, 6-7=-776/383, 7-8=-776/383,
 8-9=-739/304, 9-10=-705/231, 10-11=-749/172, 11-12=-870/129
 BOT CHORD 2-23=-39/567, 22-23=-39/567, 21-22=-39/567, 20-21=-39/567, 19-20=-39/567,
 17-19=-39/567, 16-17=-39/567, 15-16=-39/567, 14-15=-39/567, 12-14=-39/567
 WEBS 7-19=-309/660

NOTES-

- Unbalanced roof live loads have been considered for this design.
- Wind: ASCE 7-10; Vult=130mph Vasd=103mph; TCDL=6.0psf; BCDL=6.0psf; h=15ft; Cat. II; Exp C; Enclosed; MWFRS (envelope) gable end zone and C-C Exterior(2) zone; C-C for members and forces & MWFRS for reactions shown; Lumber DOL=1.60 plate grip DOL=1.60
- Truss designed for wind loads in the plane of the truss only. For studs exposed to wind (normal to the face), see Standard Industry Gable End Details as applicable, or consult qualified building designer as per ANSI/TPI 1.
- All plates are 2x4 MT20 unless otherwise indicated.
- Gable studs spaced at 2-0-0 oc.
- This truss has been designed for a 10.0 psf bottom chord live load nonconcurrent with any other live loads.
- * This truss has been designed for a live load of 30.0psf on the bottom chord in all areas where a rectangle 3-6-0 tall by 2-0-0 wide will fit between the bottom chord and any other members.
- Provide mechanical connection (by others) of truss to bearing plate capable of withstanding 100 lb uplift at joint(s) except (jt=lb) 12=169, 2=169.



March 1, 2023

WARNING - Verify design parameters and READ NOTES ON THIS AND INCLUDED MITEK REFERENCE PAGE MII-7473 rev. 5/19/2020 BEFORE USE.

Design valid for use only with MiTek® connectors. This design is based only upon parameters shown, and is for an individual building component, not a truss system. Before use, the building designer must verify the applicability of design parameters and properly incorporate this design into the overall building design. Bracing indicated is to prevent buckling of individual truss web and/or chord members only. Additional temporary and permanent bracing is always required for stability and to prevent collapse with possible personal injury and property damage. For general guidance regarding the fabrication, storage, delivery, erection and bracing of trusses and truss systems, see

ANSI/TPI1 Quality Criteria, DSB-89 and BCSI Building Component

Safety Information available from Truss Plate Institute, 2670 Crain Highway, Suite 203 Waldorf, MD 20601



818 Soundside Road
 Edenton, NC 27932

Job J0323-1214	Truss G1	Truss Type COMMON	Qty 6	Ply 1	Lot 43 Liberty Meadow 156917886
-------------------	-------------	----------------------	----------	----------	------------------------------------

Comtech, Inc. Fayetteville, NC - 28314,

8.430 s Jan 6 2022 MiTek Industries, Inc. Wed Mar 1 09:54:57 2023 Page 1

ID:aTXuLo?nW09qtpROz2WQ0wydkZW-?SJBHDV86OXPe2MabpFYjJtO5BGPXLJOGG2bgzfKAI

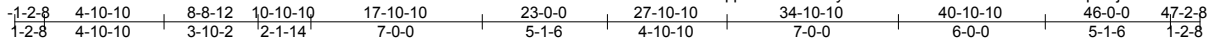

4x6 =

Scale = 1:94.1

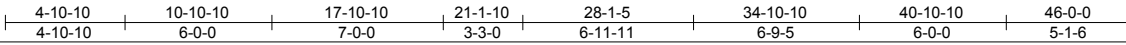
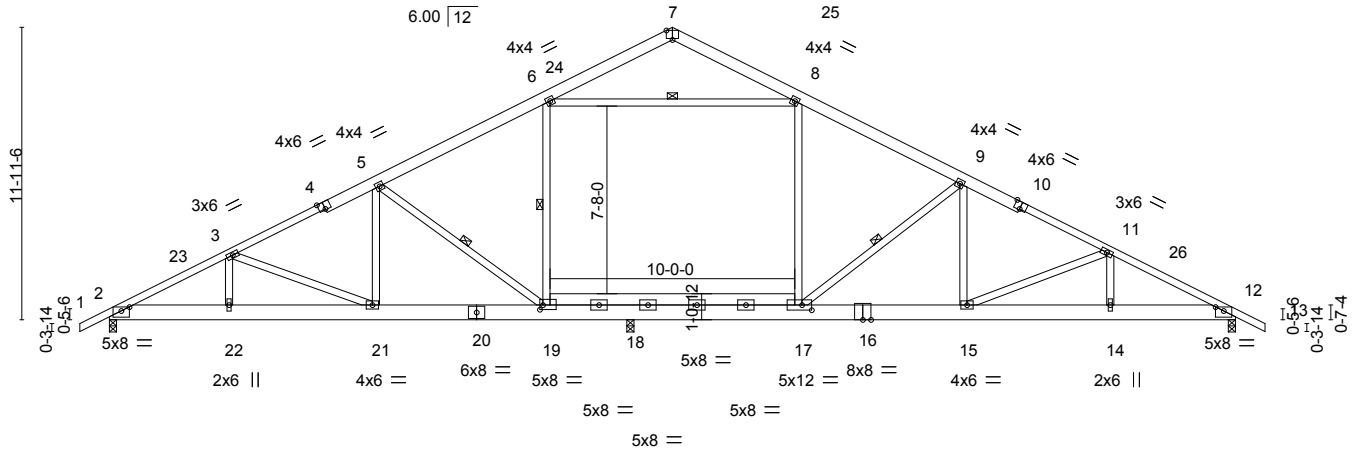

Plate Offsets (X, Y)--	[2:0-4-0,0-1-15], [4:0-3-0,Edge], [7:0-3-0,Edge], [10:0-3-0,Edge], [12:0-4-0,0-1-15], [17:0-4-12,0-2-8], [19:0-1-8,0-2-4]
------------------------	---

LOADING (psf)	SPACING-	2-0-0	CSI.	DEFL.	in (loc)	l/defl	L/d	PLATES	GRIP
TCLL 20.0	Plate Grip DOL	1.15	TC 0.26	Vert(LL)	-0.24	15-17	>999	MT20	244/190
TCDL 10.0	Lumber DOL	1.15	BC 0.44	Vert(CT)	-0.40	15-17	>739		
BCLL 0.0 *	Rep Stress Incr	YES	WB 0.42	Horz(CT)	0.03	12	n/a		
BCDL 10.0	Code IRC2015/TPI2014		Matrix-S	Wind(LL)	0.16	15-17	>999		
								Weight: 376 lb	FT = 20%

LUMBER-	BRACING-
TOP CHORD 2x6 SP No.1 *Except* 1-4,10-13: 2x4 SP No.1	TOP CHORD Structural wood sheathing directly applied or 3-11-0 oc purlins.
BOT CHORD 2x8 SP 2400F 2.OE *Except* 17-19: 2x6 SP No.1	BOT CHORD Rigid ceiling directly applied or 10-0-0 oc bracing. Except: 8-5-9 oc bracing: 18-19 7-9-4 oc bracing: 17-18.
WEBS 2x4 SP No.2	WEBS 1 Row at midpt 9-17, 6-19, 5-19, 6-8

REACTIONS. (size) 2=0-3-8, 12=0-3-8, 18=0-3-8
 Max Horz 2=156(LC 11)
 Max Uplift 2=66(LC 12), 12=168(LC 13), 18=120(LC 12)
 Max Grav 2=1250(LC 1), 12=1365(LC 24), 18=1447(LC 19)

FORCES. (lb) - Max. Comp./Max. Ten. - All forces 250 (lb) or less except when shown.
 TOP CHORD 2-3=-2175/456, 3-5=-1759/445, 5-6=-1250/413, 6-7=-378/186, 7-8=-350/181,
 8-9=-1235/382, 9-11=-2082/468, 11-12=-2367/451
 BOT CHORD 2-22=-304/1880, 21-22=-304/1880, 19-21=-194/1515, 18-19=-52/1043, 17-18=-48/1031,
 15-17=-245/1812, 14-15=-325/2045, 12-14=-325/2045
 WEBS 9-17=-1058/260, 9-15=-26/593, 5-19=-875/234, 5-21=-23/446, 3-21=-393/120,
 11-15=-281/104, 6-8=-846/319

- NOTES-**
- 1) Unbalanced roof live loads have been considered for this design.
 - 2) Wind: ASCE 7-10; Vult=130mph Vasd=103mph; TCCL=6.0psf; BCDL=6.0psf; h=15ft; Cat. II; Exp C; Enclosed; MWFRS (envelope) and C-C Exterior(2) -1-2-7 to 3-2-5, Interior(1) 3-2-5 to 23-0-0, Exterior(2) 23-0-0 to 27-4-13, Interior(1) 27-4-13 to 47-2-7 zone;C-C for members and forces & MWFRS for reactions shown; Lumber DOL=1.60 plate grip DOL=1.60
 - 3) This truss has been designed for a 10.0 psf bottom chord live load nonconcurrent with any other live loads.
 - 4) * This truss has been designed for a live load of 30.0psf on the bottom chord in all areas where a rectangle 3-6-0 tall by 2-0-0 wide will fit between the bottom chord and any other members, with BCDL = 10.0psf.
 - 5) Provide mechanical connection (by others) of truss to bearing plate capable of withstanding 100 lb uplift at joint(s) 2 except (jt=lb) 12=168, 18=120.

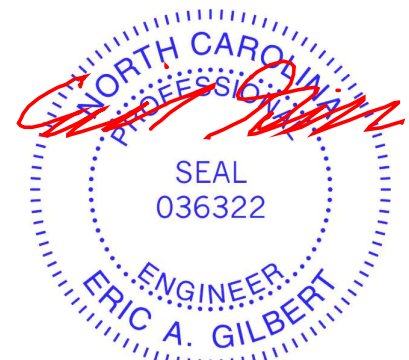

March 1, 2023

Job J0323-1214	Truss G1GE	Truss Type COMMON SUPPORTED GAB	Qty 1	Ply 1	Lot 43 Liberty Meadow I56917887
-------------------	---------------	------------------------------------	----------	----------	------------------------------------

Comtech, Inc. Fayetteville, NC - 28314,

8.430 s Jan 6 2022 MiTek Industries, Inc. Wed Mar 1 09:55:00 2023 Page 1

ID:aTXuLo?nW09qtpROz2WQ0wydkZW-Q1_KvEX0PJw_45nxFjMyALxRZIJPcyol4EUIc?zfkAf

Job Reference (optional)

1-2-8	23-0-0	46-0-0	47-2-8
1-2-8	23-0-0	23-0-0	1-2-8

Scale = 1:81.7

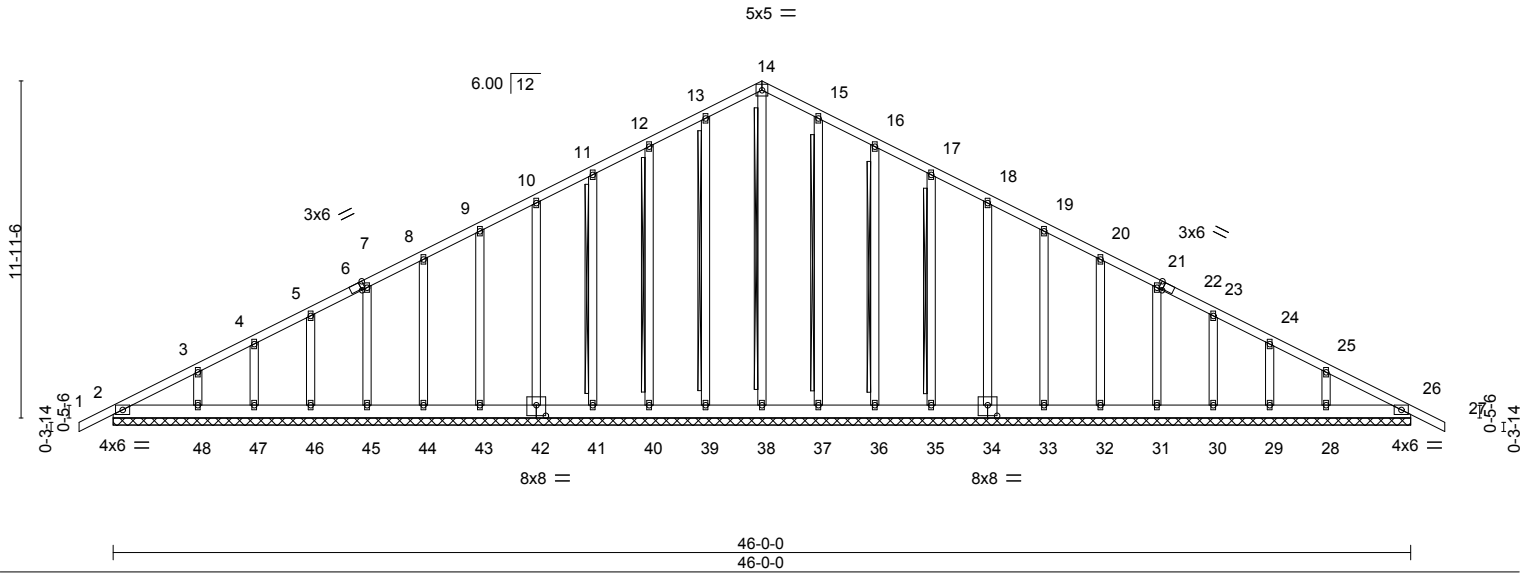

Plate Offsets (X,Y)-- [6:0-1-9,Edge], [22:0-1-9,Edge], [34:0-4-0,0-4-8], [42:0-4-0,0-4-8]

LOADING (psf)	SPACING-	2-0-0	CSI.	DEFL.	in (loc)	l/defl	L/d	PLATES	GRIP
TCLL 20.0	Plate Grip DOL	1.15	TC 0.07	Vert(LL)	-0.00	27	n/r	MT20	244/190
TCDL 10.0	Lumber DOL	1.15	BC 0.03	Vert(CT)	-0.00	27	n/r		
BCLL 0.0 *	Rep Stress Incr	YES	WB 0.18	Horz(CT)	0.01	26	n/a		
BCDL 10.0	Code IRC2015/TPI2014		Matrix-S						
								Weight: 376 lb	FT = 20%

LUMBER-
 TOP CHORD 2x4 SP No.1
 BOT CHORD 2x6 SP No.1
 OTHERS 2x4 SP No.2

BRACING-
 TOP CHORD Structural wood sheathing directly applied or 6-0-0 oc purlins.
 BOT CHORD Rigid ceiling directly applied or 10-0-0 oc bracing.
 WEBS T-Brace: 2x4 SPF No.2 - 14-38, 13-39, 12-40, 11-41, 15-37, 16-36, 17-35
 Fasten (2X) T and I braces to narrow edge of web with 10d (0.131"x3") nails, 6in o.c., with 3in minimum end distance.
 Brace must cover 90% of web length.

REACTIONS. All bearings 46-0-0.
 (lb) - Max Horz 2=245(LC 16)
 Max Uplift All uplift 100 lb or less at joint(s) 2, 39, 40, 41, 42, 43, 44, 45, 46, 47, 48, 37, 36, 35, 34, 33, 32, 31, 30, 29, 28, 26
 Max Grav All reactions 250 lb or less at joint(s) 2, 38, 39, 40, 41, 42, 43, 44, 45, 46, 47, 48, 37, 36, 35, 34, 33, 32, 31, 30, 29, 28, 26

FORCES. (lb) - Max. Comp./Max. Ten. - All forces 250 (lb) or less except when shown.
 TOP CHORD 2-3=-322/96, 11-12=-106/275, 12-13=-127/337, 13-14=-146/387, 14-15=-146/387, 15-16=-127/337, 16-17=-106/275
 BOT CHORD 2-48=-82/271, 47-48=-82/271, 46-47=-82/271, 45-46=-82/271, 44-45=-82/271, 43-44=-82/271, 42-43=-82/271, 41-42=-82/271, 40-41=-82/271, 39-40=-82/271, 38-39=-82/271, 37-38=-82/271, 36-37=-82/271, 35-36=-82/271, 34-35=-82/271, 33-34=-82/271, 32-33=-82/271, 31-32=-82/271, 30-31=-82/271, 29-30=-82/271, 28-29=-82/271, 26-28=-82/271

- NOTES-**
- 1) Unbalanced roof live loads have been considered for this design.
 - 2) Wind: ASCE 7-10; Vult=130mph Vasd=103mph; TC DL=6.0psf; BCDL=6.0psf; h=15ft; Cat. II; Exp C; Enclosed; MWFRS (envelope) gable end zone and C-C Exterior(2) zone; C-C for members and forces & MWFRS for reactions shown; Lumber DOL=1.60 plate grip DOL=1.60
 - 3) Truss designed for wind loads in the plane of the truss only. For studs exposed to wind (normal to the face), see Standard Industry Gable End Details as applicable, or consult qualified building designer as per ANSI/TPI 1.
 - 4) All plates are 2x4 MT20 unless otherwise indicated.
 - 5) Gable requires continuous bottom chord bearing.
 - 6) Gable studs spaced at 2-0-0 oc.
 - 7) This truss has been designed for a 10.0 psf bottom chord live load nonconcurrent with any other live loads.
 - 8) * This truss has been designed for a live load of 30.0psf on the bottom chord in all areas where a rectangle 3-6-0 tall by 2-0-0 wide will fit between the bottom chord and any other members.
 - 9) Provide mechanical connection (by others) of truss to bearing plate capable of withstanding 100 lb uplift at joint(s) 2, 39, 40, 41, 42, 43, 44, 45, 46, 47, 48, 37, 36, 35, 34, 33, 32, 31, 30, 29, 28, 26.
 - 10) Warning: Additional permanent and stability bracing for truss system (not part of this component design) is always required.

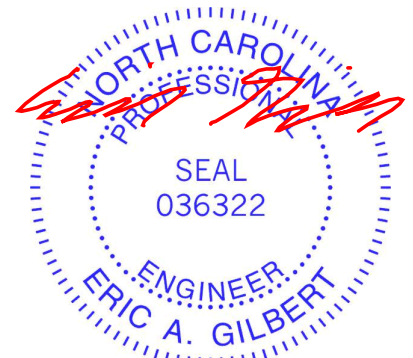

March 1, 2023

WARNING - Verify design parameters and READ NOTES ON THIS AND INCLUDED MITEK REFERENCE PAGE MII-7473 rev. 5/19/2020 BEFORE USE.

Design valid for use only with MiTek® connectors. This design is based only upon parameters shown, and is for an individual building component, not a truss system. Before use, the building designer must verify the applicability of design parameters and properly incorporate this design into the overall building design. Bracing indicated is to prevent buckling of individual truss web and/or chord members only. Additional temporary and permanent bracing is always required for stability and to prevent collapse with possible personal injury and property damage. For general guidance regarding the fabrication, storage, delivery, erection and bracing of trusses and truss systems, see **ANSI/TPI1 Quality Criteria, DSB-89 and BCSI Building Component Safety Information** available from Truss Plate Institute, 2670 Crain Highway, Suite 203 Waldorf, MD 20601



818 Soundside Road
 Edenton, NC 27932

Job J0323-1214	Truss J1	Truss Type MONO TRUSS	Qty 4	Ply 1	Lot 43 Liberty Meadow I56917888
-------------------	-------------	--------------------------	----------	----------	------------------------------------

Comtech, Inc. Fayetteville, NC - 28314,

8.430 s Jan 6 2022 MiTek Industries, Inc. Wed Mar 1 09:55:02 2023 Page 1

ID:aTXuLo?nW09qtpROz2WQ0wydkZW-MQ64KwYGxwAikPxn8PQFm1j6zP4t52YzpzGtzfKAd



Scale = 1:14.8

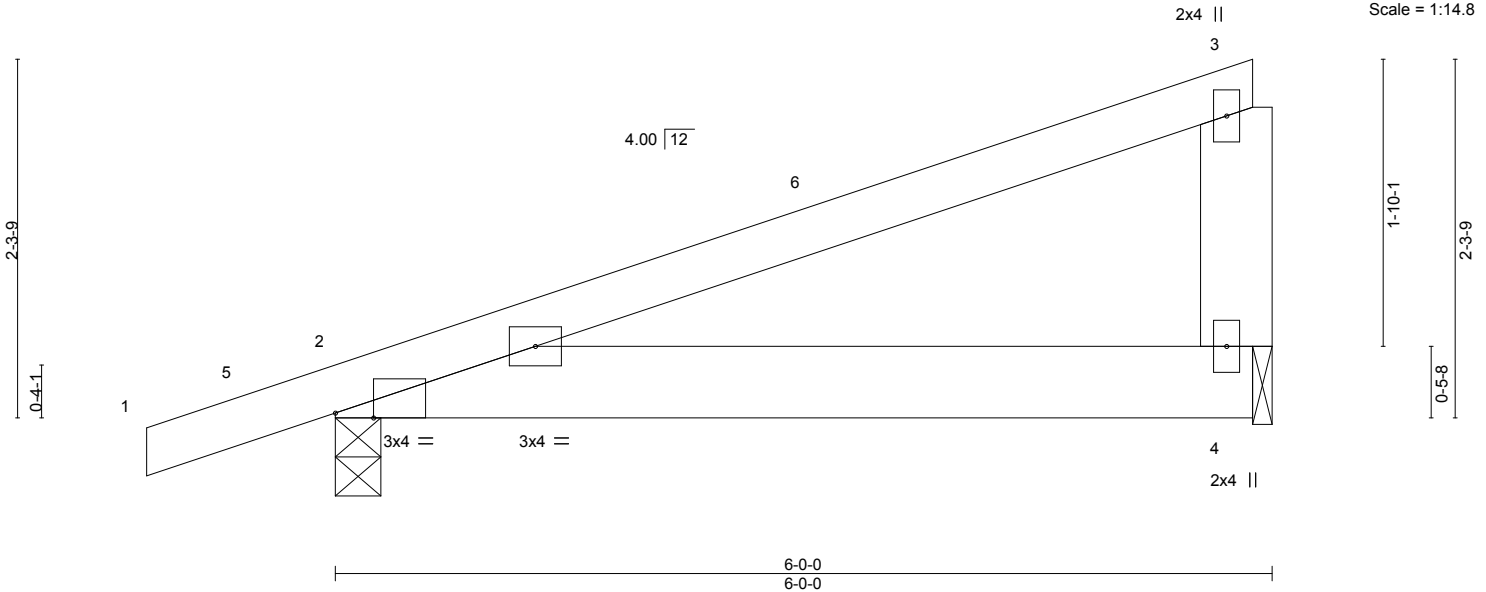

LOADING (psf)	SPACING-	CSI.	DEFL.	PLATES	GRIP
TCLL 20.0	2-0-0	TC 0.41	in (loc) l/defl L/d	MT20	244/190
TCDL 10.0	Plate Grip DOL 1.15	BC 0.12	Vert(LL) -0.01 2-4 >999 360		
BCLL 0.0 *	Lumber DOL 1.15	WB 0.00	Vert(CT) -0.03 2-4 >999 240		
BCDL 10.0	Rep Stress Incr YES	Matrix-P	Horz(CT) 0.00 n/a n/a		
	Code IRC2015/TPI2014		Wind(LL) 0.03 2-4 >999 240	Weight: 29 lb	FT = 20%

LUMBER-	BRACING-
TOP CHORD 2x4 SP No.1	TOP CHORD Structural wood sheathing directly applied or 6-0-0 oc purlins, except end verticals.
BOT CHORD 2x6 SP No.1	BOT CHORD Rigid ceiling directly applied or 10-0-0 oc bracing.
WEBS 2x6 SP No.1	

REACTIONS. (size) 2=0-3-8, 4=0-1-8
 Max Horz 2=83(LC 8)
 Max Uplift 2=-132(LC 8), 4=-90(LC 8)
 Max Grav 2=316(LC 1), 4=215(LC 1)

FORCES. (lb) - Max. Comp./Max. Ten. - All forces 250 (lb) or less except when shown.

- NOTES-**
- 1) Wind: ASCE 7-10; Vult=130mph Vasd=103mph; TCDL=6.0psf; BCDL=6.0psf; h=15ft; Cat. II; Exp C; Enclosed; MWFRS (envelope) and C-C Exterior(2) -1-2-8 to 3-2-5, Interior(1) 3-2-5 to 5-9-4 zone; porch left exposed; C-C for members and forces & MWFRS for reactions shown; Lumber DOL=1.60 plate grip DOL=1.60
 - 2) This truss has been designed for a 10.0 psf bottom chord live load nonconcurrent with any other live loads.
 - 3) * This truss has been designed for a live load of 30.0psf on the bottom chord in all areas where a rectangle 3-6-0 tall by 2-0-0 wide will fit between the bottom chord and any other members.
 - 4) Bearing at joint(s) 4 considers parallel to grain value using ANSI/TPI 1 angle to grain formula. Building designer should verify capacity of bearing surface.
 - 5) Provide mechanical connection (by others) of truss to bearing plate at joint(s) 4.
 - 6) Provide mechanical connection (by others) of truss to bearing plate capable of withstanding 100 lb uplift at joint(s) 4 except (jt=lb) 2=132.

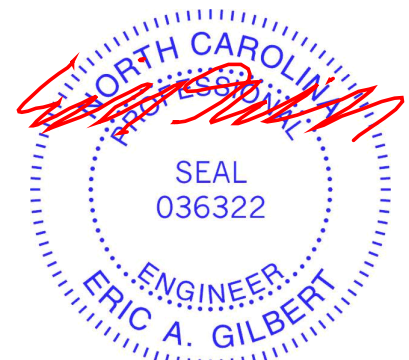

March 1, 2023

Job	Truss	Truss Type	Qty	Ply	Lot 43 Liberty Meadow	I56917889
J0323-1214	J2	MONOPIITCH	6	1		

Comtech, Inc. Fayetteville, NC - 28314,

8.430 s Jan 6 2022 MiTek Industries, Inc. Wed Mar 1 09:55:03 2023 Page 1

ID:aTXuLo?nW09qtpROz2WQ0wydkZW-qcgTXGZuiEIzYzVWxrwo_ZvtWJHpKLCmCjMpJzfkAc



Scale = 1:12.5

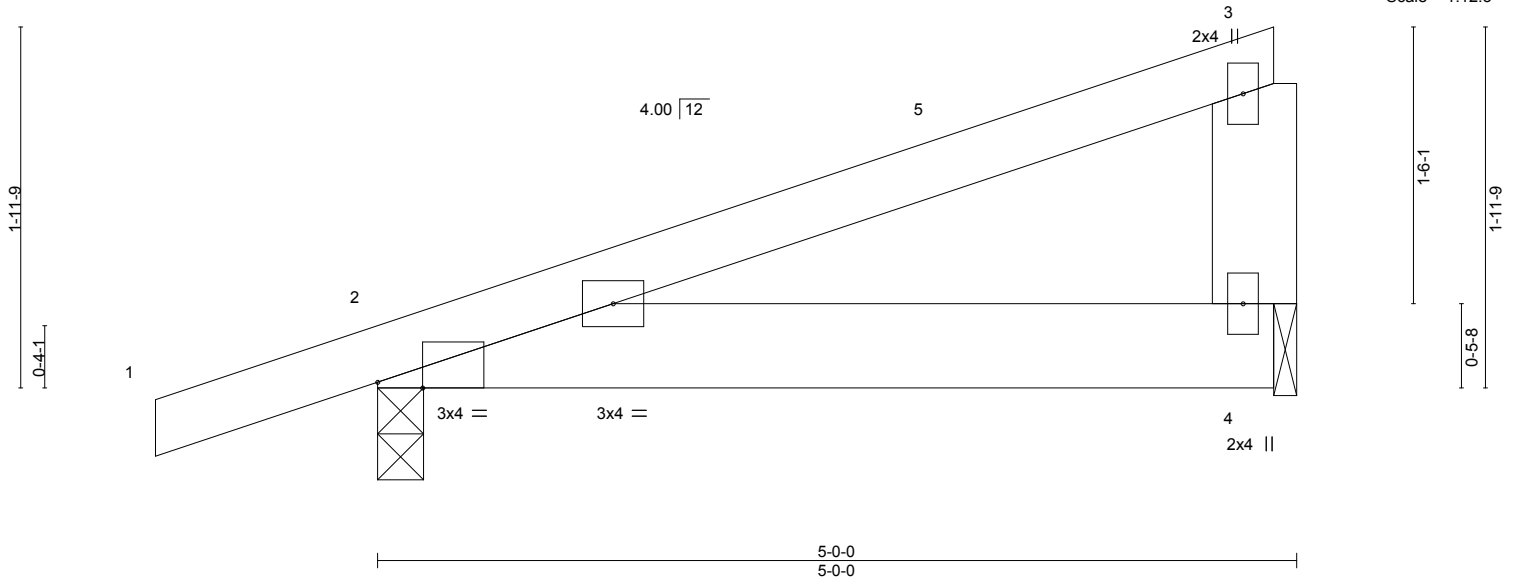

Plate Offsets (X,Y)--	[2:0-2-15,Edge]
-----------------------	-----------------

LOADING (psf)	SPACING-	2-0-0	CSI.	DEFL.	in (loc)	l/defl	L/d	PLATES	GRIP
TCLL 20.0	Plate Grip DOL	1.15	TC 0.26	Vert(LL)	-0.01	2-4	>999	MT20	244/190
TCDL 10.0	Lumber DOL	1.15	BC 0.08	Vert(CT)	-0.01	2-4	>999		
BCLL 0.0 *	Rep Stress Incr	YES	WB 0.00	Horz(CT)	0.00	n/a	n/a		
BCDL 10.0	Code IRC2015/TPI2014		Matrix-P	Wind(LL)	0.01	2-4	>999	Weight: 24 lb	FT = 20%

LUMBER-	BRACING-
TOP CHORD 2x4 SP No.1	TOP CHORD Structural wood sheathing directly applied or 5-0-0 oc purlins, except end verticals.
BOT CHORD 2x6 SP No.1	BOT CHORD Rigid ceiling directly applied or 10-0-0 oc bracing.
WEBS 2x6 SP No.1	

REACTIONS. (size) 2=0-3-0, 4=0-1-8
 Max Horz 2=72(LC 8)
 Max Uplift 2=-119(LC 8), 4=-72(LC 8)
 Max Grav 2=277(LC 1), 4=174(LC 1)

FORCES. (lb) - Max. Comp./Max. Ten. - All forces 250 (lb) or less except when shown.

- NOTES-**
- 1) Wind: ASCE 7-10; Vult=130mph Vasd=103mph; TCDL=6.0psf; BCDL=6.0psf; h=15ft; Cat. II; Exp C; Enclosed; MWFRS (envelope) and C-C Exterior(2) -1-2-8 to 3-2-5, Interior(1) 3-2-5 to 4-9-4 zone; porch left exposed; C-C for members and forces & MWFRS for reactions shown; Lumber DOL=1.60 plate grip DOL=1.60
 - 2) This truss has been designed for a 10.0 psf bottom chord live load nonconcurrent with any other live loads.
 - 3) * This truss has been designed for a live load of 30.0psf on the bottom chord in all areas where a rectangle 3-6-0 tall by 2-0-0 wide will fit between the bottom chord and any other members.
 - 4) Bearing at joint(s) 4 considers parallel to grain value using ANSI/TPI 1 angle to grain formula. Building designer should verify capacity of bearing surface.
 - 5) Provide mechanical connection (by others) of truss to bearing plate at joint(s) 4.
 - 6) Provide mechanical connection (by others) of truss to bearing plate capable of withstanding 100 lb uplift at joint(s) 4 except (jt=lb) 2=119.

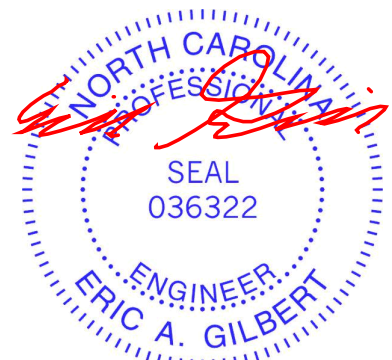

March 1, 2023

<p>WARNING - Verify design parameters and READ NOTES ON THIS AND INCLUDED MITEK REFERENCE PAGE MII-7473 rev. 5/19/2020 BEFORE USE.</p> <p>Design valid for use only with MiTek® connectors. This design is based only upon parameters shown, and is for an individual building component, not a truss system. Before use, the building designer must verify the applicability of design parameters and properly incorporate this design into the overall building design. Bracing indicated is to prevent buckling of individual truss web and/or chord members only. Additional temporary and permanent bracing is always required for stability and to prevent collapse with possible personal injury and property damage. For general guidance regarding the fabrication, storage, delivery, erection and bracing of trusses and truss systems, see ANSI/TPI1 Quality Criteria, DSB-89 and BCSI Building Component Safety Information available from Truss Plate Institute, 2670 Crain Highway, Suite 203 Waldorf, MD 20601</p>	<p>ENGINEERING BY</p> <p>A MiTek Affiliate</p> <p>818 Soundside Road Edenton, NC 27932</p>
--	--

Job	Truss	Truss Type	Qty	Ply	Lot 43 Liberty Meadow	I56917890
J0323-1214	J2GE	MONOPITCH SUPPORTED	1	1		
					Job Reference (optional)	

Comtech, Inc. Fayetteville, NC - 28314,

8.430 s Jan 6 2022 MiTek Industries, Inc. Wed Mar 1 09:55:05 2023 Page 1

ID:aTXuLo?nW09qtPROz2WQ0wydkZW-m?oDyyb9ErYHBSfv2Gy7tPflJ0hHEMVEWCTtCzfkAa

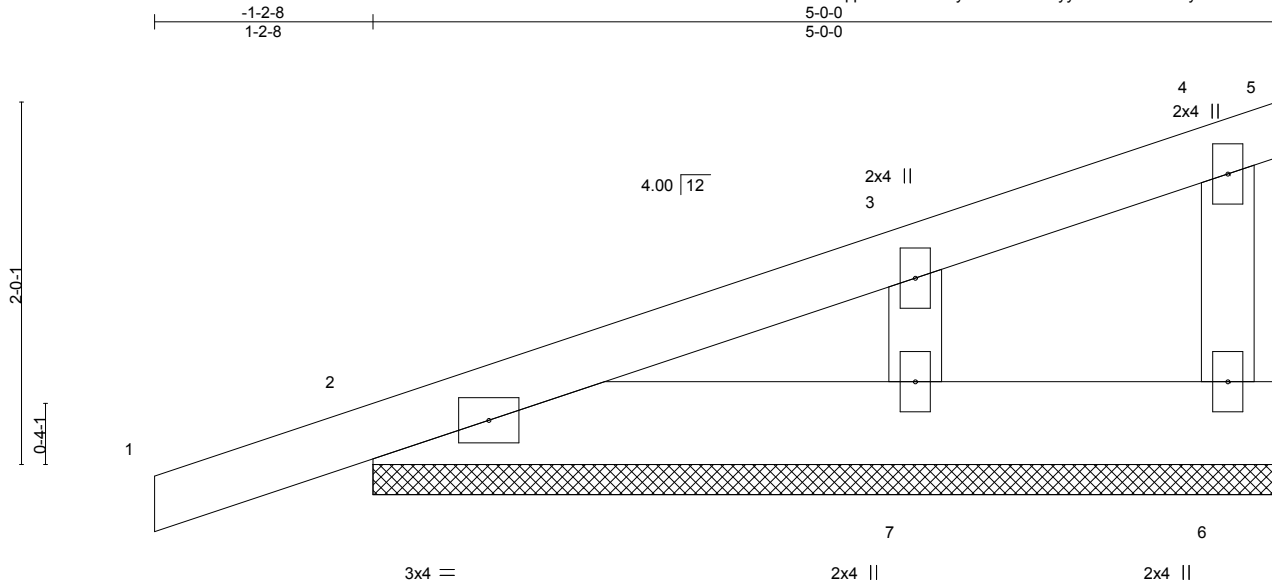

LOADING (psf)	SPACING-	2-0-0	CSI.	DEFL.	in (loc)	l/defl	L/d	PLATES	GRIP	
TCLL 20.0	Plate Grip DOL	1.15	TC 0.07	Vert(LL)	0.00	1	n/r	120	MT20	244/190
TCDL 10.0	Lumber DOL	1.15	BC 0.02	Vert(CT)	0.00	1	n/r	120		
BCLL 0.0 *	Rep Stress Incr	YES	WB 0.03	Horz(CT)	-0.00	5	n/a	n/a		
BCDL 10.0	Code IRC2015/TPI2014		Matrix-P						Weight: 24 lb	FT = 20%

LUMBER-
 TOP CHORD 2x4 SP No.1
 BOT CHORD 2x6 SP No.1
 WEBS 2x4 SP No.2
 OTHERS 2x4 SP No.2

BRACING-
 TOP CHORD Structural wood sheathing directly applied or 5-0-0 oc purlins, except end verticals.
 BOT CHORD Rigid ceiling directly applied or 10-0-0 oc bracing.

REACTIONS. All bearings 5-0-0.
 (lb) - Max Horz 2=104(LC 8)
 Max Uplift All uplift 100 lb or less at joint(s) 5, 6, 2, 7
 Max Grav All reactions 250 lb or less at joint(s) 5, 6, 2, 7

FORCES. (lb) - Max. Comp./Max. Ten. - All forces 250 (lb) or less except when shown.

- NOTES-**
- 1) Wind: ASCE 7-10; Vult=130mph Vasd=103mph; TC DL=6.0psf; BCDL=6.0psf; h=15ft; Cat. II; Exp C; Enclosed; MWFRS (envelope) gable end zone and C-C Exterior(2) zone; C-C for members and forces & MWFRS for reactions shown; Lumber DOL=1.60 plate grip DOL=1.60
 - 2) Truss designed for wind loads in the plane of the truss only. For studs exposed to wind (normal to the face), see Standard Industry Gable End Details as applicable, or consult qualified building designer as per ANSI/TPI 1.
 - 3) Gable requires continuous bottom chord bearing.
 - 4) Gable studs spaced at 2-0-0 oc.
 - 5) This truss has been designed for a 10.0 psf bottom chord live load nonconcurrent with any other live loads.
 - 6) * This truss has been designed for a live load of 30.0psf on the bottom chord in all areas where a rectangle 3-6-0 tall by 2-0-0 wide will fit between the bottom chord and any other members.
 - 7) Provide mechanical connection (by others) of truss to bearing plate capable of withstanding 100 lb uplift at joint(s) 5, 6, 2, 7.
 - 8) Beveled plate or shim required to provide full bearing surface with truss chord at joint(s) 2.

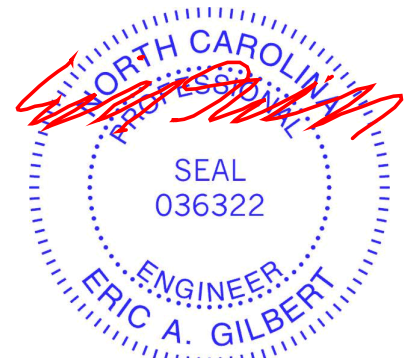

March 1, 2023

WARNING - Verify design parameters and READ NOTES ON THIS AND INCLUDED MITEK REFERENCE PAGE MII-7473 rev. 5/19/2020 BEFORE USE.
 Design valid for use only with MiTek® connectors. This design is based only upon parameters shown, and is for an individual building component, not a truss system. Before use, the building designer must verify the applicability of design parameters and properly incorporate this design into the overall building design. Bracing indicated is to prevent buckling of individual truss web and/or chord members only. Additional temporary and permanent bracing is always required for stability and to prevent collapse with possible personal injury and property damage. For general guidance regarding the fabrication, storage, delivery, erection and bracing of trusses and truss systems, see **ANSI/TPI1 Quality Criteria, DSB-89 and BCSI Building Component Safety Information** available from Truss Plate Institute, 2670 Crain Highway, Suite 203 Waldorf, MD 20601

ENGINEERING BY
TRENCO
 A MiTek Affiliate
 818 Soundside Road
 Edenton, NC 27932

Job J0323-1214	Truss J3	Truss Type MONOPICH	Qty 9	Ply 1	Lot 43 Liberty Meadow Job Reference (optional)	156917891
-------------------	-------------	------------------------	----------	----------	---	-----------

Comtech, Inc. Fayetteville, NC - 28314,

8.430 s Jan 6 2022 MiTek Industries, Inc. Wed Mar 1 09:55:06 2023 Page 1

ID:aTXuLo?nW09qtpROz2WQ0wydkZW-FBmB9lcn?9g8p0E5c_TMqcbTmjMk0h_eTAX0PezfKAZ

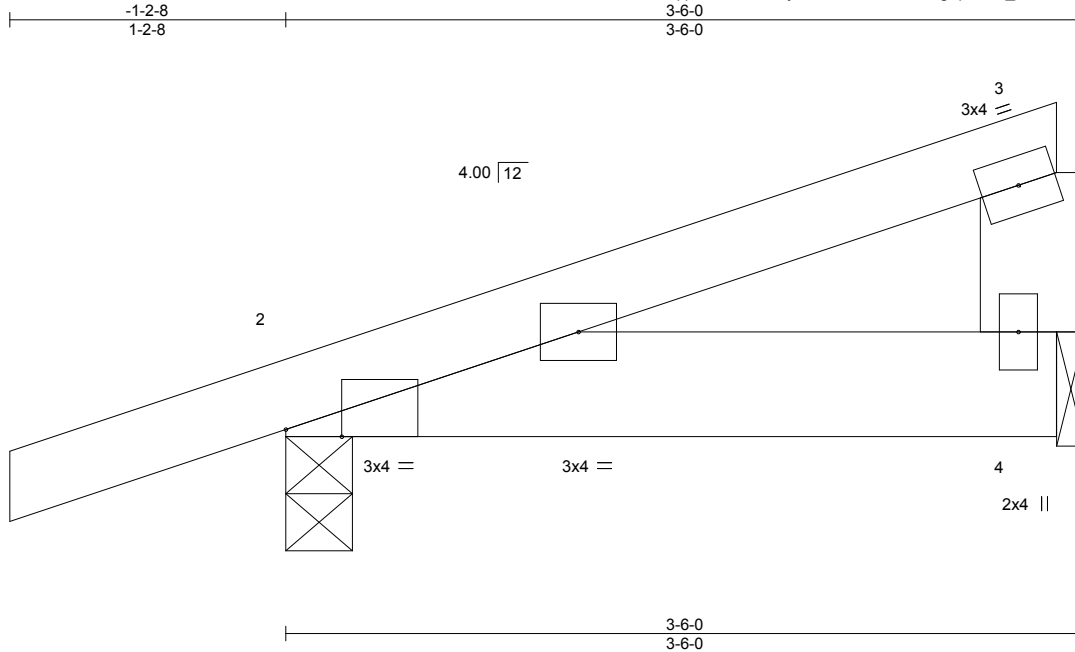

Scale = 1:10.1

LOADING (psf)	SPACING-	2-0-0	CSI.	DEFL.	in (loc)	l/defl	L/d	PLATES	GRIP
TCLL 20.0	Plate Grip DOL	1.15	TC 0.09	Vert(LL)	-0.00	2-4	>999	MT20	244/190
TCDL 10.0	Lumber DOL	1.15	BC 0.03	Vert(CT)	-0.00	2-4	>999		
BCLL 0.0 *	Rep Stress Incr	YES	WB 0.01	Horz(CT)	0.00	n/a	n/a		
BCDL 10.0	Code IRC2015/TPI2014		Matrix-P	Wind(LL)	0.00	2	****	Weight: 17 lb	FT = 20%

LUMBER-	BRACING-
TOP CHORD 2x4 SP No.1	TOP CHORD Structural wood sheathing directly applied or 3-6-0 oc purlins.
BOT CHORD 2x6 SP No.1	BOT CHORD Rigid ceiling directly applied or 10-0-0 oc bracing.
WEBS 2x6 SP No.1	

REACTIONS. (size) 2=0-3-8, 4=0-1-8
 Max Horz 2=56(LC 8)
 Max Uplift 2=69(LC 8), 4=14(LC 12)
 Max Grav 2=224(LC 1), 4=107(LC 1)

FORCES. (lb) - Max. Comp./Max. Ten. - All forces 250 (lb) or less except when shown.

- NOTES-**
- 1) Wind: ASCE 7-10; Vult=130mph Vasd=103mph; TCDL=6.0psf; BCDL=6.0psf; h=15ft; Cat. II; Exp C; Enclosed; MWFRS (envelope) and C-C Exterior(2) zone; C-C for members and forces & MWFRS for reactions shown; Lumber DOL=1.60 plate grip DOL=1.60
 - 2) This truss has been designed for a 10.0 psf bottom chord live load nonconcurrent with any other live loads.
 - 3) * This truss has been designed for a live load of 30.0psf on the bottom chord in all areas where a rectangle 3-6-0 tall by 2-0-0 wide will fit between the bottom chord and any other members.
 - 4) Bearing at joint(s) 4 considers parallel to grain value using ANSI/TPI 1 angle to grain formula. Building designer should verify capacity of bearing surface.
 - 5) Provide mechanical connection (by others) of truss to bearing plate at joint(s) 4.
 - 6) Provide mechanical connection (by others) of truss to bearing plate capable of withstanding 100 lb uplift at joint(s) 2, 4.

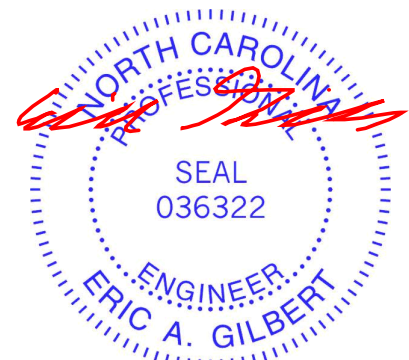

March 1, 2023

WARNING - Verify design parameters and READ NOTES ON THIS AND INCLUDED MITEK REFERENCE PAGE MII-7473 rev. 5/19/2020 BEFORE USE.
 Design valid for use only with MiTek® connectors. This design is based only upon parameters shown, and is for an individual building component, not a truss system. Before use, the building designer must verify the applicability of design parameters and properly incorporate this design into the overall building design. Bracing indicated is to prevent buckling of individual truss web and/or chord members only. Additional temporary and permanent bracing is always required for stability and to prevent collapse with possible personal injury and property damage. For general guidance regarding the fabrication, storage, delivery, erection and bracing of trusses and truss systems, see **ANSI/TPI1 Quality Criteria, DSB-89 and BCSI Building Component Safety Information** available from Truss Plate Institute, 2670 Crain Highway, Suite 203 Waldorf, MD 20601

ENGINEERING BY
TRENCO
 A MiTek Affiliate
 818 Soundside Road
 Edenton, NC 27932

Job J0323-1214	Truss J3GE	Truss Type MONOPITCH SUPPORTED	Qty 2	Ply 1	Lot 43 Liberty Meadow I56917892
-------------------	---------------	-----------------------------------	----------	----------	------------------------------------

Comtech, Inc. Fayetteville, NC - 28314,

8.430 s Jan 6 2022 MiTek Industries, Inc. Wed Mar 1 09:55:07 2023 Page 1

ID:aTXuLo?nW09qtpROz2WQ0wydkZW-jNvzNecPmSo?QApHAh_byqkdo7iBI84nhqhay5zfrKAY

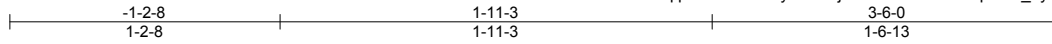

Scale = 1:10.3

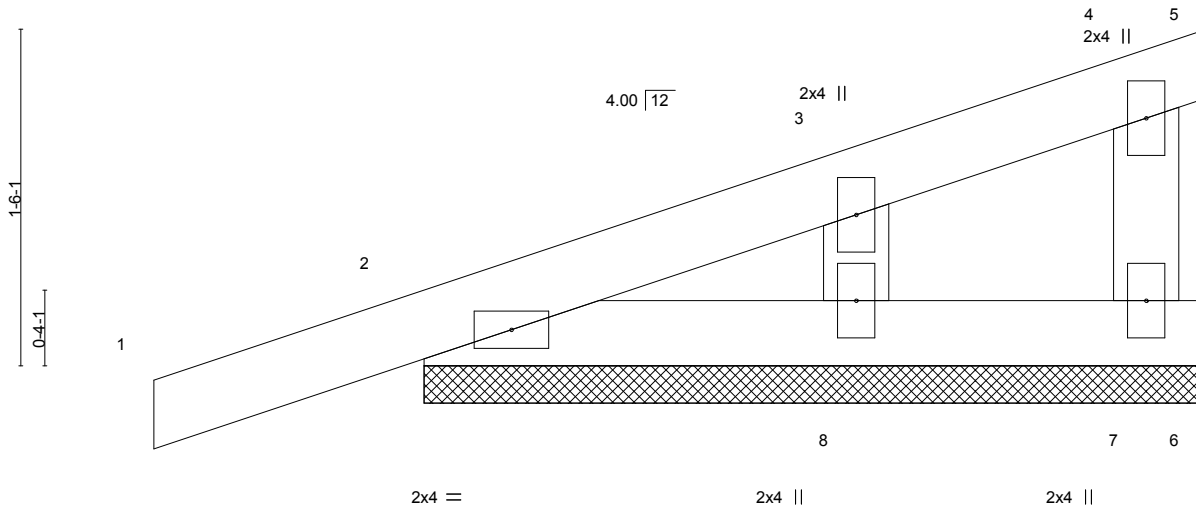

LOADING (psf)	SPACING-	2-0-0	CSI.	DEFL.	in (loc)	l/defl	L/d	PLATES	GRIP	
TCLL 20.0	Plate Grip DOL	1.15	TC 0.07	Vert(LL)	0.00	4	n/r	120	MT20	244/190
TCDL 10.0	Lumber DOL	1.15	BC 0.02	Vert(CT)	0.00	4	n/r	120		
BCLL 0.0 *	Rep Stress Incr	YES	WB 0.02	Horz(CT)	0.00		n/a	n/a		
BCDL 10.0	Code IRC2015/TPI2014		Matrix-P						Weight: 15 lb	FT = 20%

LUMBER-
 TOP CHORD 2x4 SP No.1
 BOT CHORD 2x4 SP No.1
 WEBS 2x4 SP No.2

BRACING-
 TOP CHORD Structural wood sheathing directly applied or 3-6-0 oc purlins, except end verticals.
 BOT CHORD Rigid ceiling directly applied or 10-0-0 oc bracing.

REACTIONS. (size) 7=3-6-0, 2=3-6-0, 8=3-6-0
 Max Horz 2=79(LC 8)
 Max Uplift 7=-26(LC 8), 2=-91(LC 8), 8=-38(LC 12)
 Max Grav 7=52(LC 1), 2=164(LC 1), 8=125(LC 1)

FORCES. (lb) - Max. Comp./Max. Ten. - All forces 250 (lb) or less except when shown.

NOTES-

- 1) Wind: ASCE 7-10; Vult=130mph Vasd=103mph; TCCL=6.0psf; BCDL=6.0psf; h=15ft; Cat. II; Exp C; Enclosed; MWFRS (envelope) gable end zone and C-C Exterior(2) zone; C-C for members and forces & MWFRS for reactions shown; Lumber DOL=1.60 plate grip DOL=1.60
- 2) Truss designed for wind loads in the plane of the truss only. For studs exposed to wind (normal to the face), see Standard Industry Gable End Details as applicable, or consult qualified building designer as per ANSI/TPI 1.
- 3) Gable requires continuous bottom chord bearing.
- 4) Gable studs spaced at 2-0-0 oc.
- 5) This truss has been designed for a 10.0 psf bottom chord live load nonconcurrent with any other live loads.
- 6) * This truss has been designed for a live load of 30.0psf on the bottom chord in all areas where a rectangle 3-6-0 tall by 2-0-0 wide will fit between the bottom chord and any other members.
- 7) Provide mechanical connection (by others) of truss to bearing plate capable of withstanding 100 lb uplift at joint(s) 7, 2, 8.

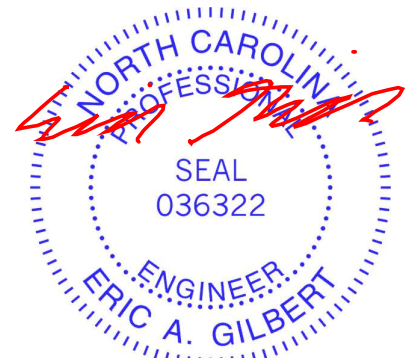

March 1, 2023

WARNING - Verify design parameters and READ NOTES ON THIS AND INCLUDED MITEK REFERENCE PAGE MII-7473 rev. 5/19/2020 BEFORE USE.

Design valid for use only with MiTek® connectors. This design is based only upon parameters shown, and is for an individual building component, not a truss system. Before use, the building designer must verify the applicability of design parameters and properly incorporate this design into the overall building design. Bracing indicated is to prevent buckling of individual truss web and/or chord members only. Additional temporary and permanent bracing is always required for stability and to prevent collapse with possible personal injury and property damage. For general guidance regarding the fabrication, storage, delivery, erection and bracing of trusses and truss systems, see **ANSI/TPI1 Quality Criteria, DSB-89 and BCSI Building Component Safety Information** available from Truss Plate Institute, 2670 Crain Highway, Suite 203 Waldorf, MD 20601



818 Soundside Road
 Edenton, NC 27932

Job J0323-1214	Truss V1	Truss Type VALLEY	Qty 1	Ply 1	Lot 43 Liberty Meadow I56917893
-------------------	-------------	----------------------	----------	----------	------------------------------------

Comtech, Inc. Fayetteville, NC - 28314,

8.430 s Jan 6 2022 MiTek Industries, Inc. Wed Mar 1 09:55:08 2023 Page 1

ID:aTXuLo?nW09qtpROz2WQ0wydkZW-BaTMazd1Xmwr2KOUjPVqV1Hm3X0zUZWxwUQ7UXzfkAX

Job Reference (optional)

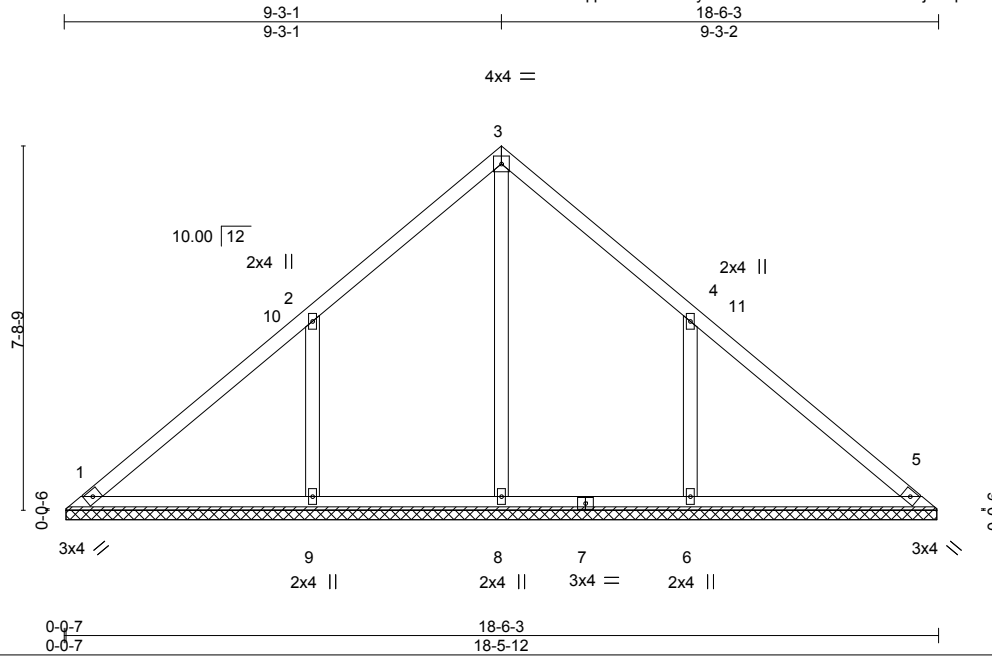

Scale = 1:48.8

Plate Offsets (X,Y)--	[4:0-0-0,0-0-0]								
LOADING (psf)	SPACING-	2-0-0	CSI.	DEFL.	in (loc)	l/defl	L/d	PLATES	GRIP
TCLL 20.0	Plate Grip DOL	1.15	TC 0.23	Vert(LL)	n/a	-	n/a	MT20	244/190
TCDL 10.0	Lumber DOL	1.15	BC 0.18	Vert(CT)	n/a	-	n/a		
BCLL 0.0 *	Rep Stress Incr	YES	WB 0.13	Horz(CT)	0.00	5	n/a		
BCDL 10.0	Code IRC2015/TPI2014		Matrix-S					Weight: 84 lb	FT = 20%

LUMBER-
 TOP CHORD 2x4 SP No.1
 BOT CHORD 2x4 SP No.1
 OTHERS 2x4 SP No.2

BRACING-
 TOP CHORD Structural wood sheathing directly applied or 6-0-0 oc purlins.
 BOT CHORD Rigid ceiling directly applied or 10-0-0 oc bracing.

REACTIONS. All bearings 18-5-5.
 (lb) - Max Horz 1=177(LC 11)
 Max Uplift All uplift 100 lb or less at joint(s) 1 except 9=-172(LC 12), 6=-172(LC 13)
 Max Grav All reactions 250 lb or less at joint(s) 1, 5 except 8=411(LC 22), 9=560(LC 19), 6=560(LC 20)

FORCES. (lb) - Max. Comp./Max. Ten. - All forces 250 (lb) or less except when shown.
 WEBS 2-9=-428/293, 4-6=-428/292

- NOTES-**
- 1) Unbalanced roof live loads have been considered for this design.
 - 2) Wind: ASCE 7-10; Vult=130mph Vasd=103mph; TC DL=6.0psf; BCDL=6.0psf; h=15ft; Cat. II; Exp C; Enclosed; MWFRS (envelope) and C-C Exterior(2) 0-4-13 to 4-9-10, Interior(1) 4-9-10 to 9-3-1, Exterior(2) 9-3-1 to 13-7-14, Interior(1) 13-7-14 to 18-1-6 zone; C-C for members and forces & MWFRS for reactions shown; Lumber DOL=1.60 plate grip DOL=1.60
 - 3) Gable requires continuous bottom chord bearing.
 - 4) This truss has been designed for a 10.0 psf bottom chord live load nonconcurrent with any other live loads.
 - 5) * This truss has been designed for a live load of 30.0psf on the bottom chord in all areas where a rectangle 3-6-0 tall by 2-0-0 wide will fit between the bottom chord and any other members, with BCDL = 10.0psf.
 - 6) Provide mechanical connection (by others) of truss to bearing plate capable of withstanding 100 lb uplift at joint(s) 1 except (jt=lb) 9=172, 6=172.

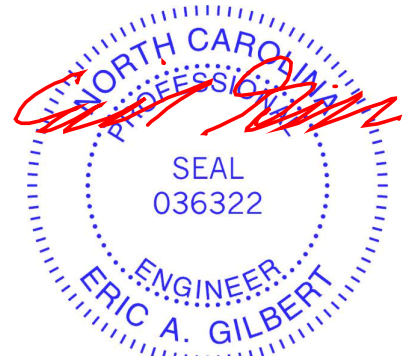

March 1, 2023

WARNING - Verify design parameters and READ NOTES ON THIS AND INCLUDED MITEK REFERENCE PAGE MII-7473 rev. 5/19/2020 BEFORE USE.
 Design valid for use only with MiTek® connectors. This design is based only upon parameters shown, and is for an individual building component, not a truss system. Before use, the building designer must verify the applicability of design parameters and properly incorporate this design into the overall building design. Bracing indicated is to prevent buckling of individual truss web and/or chord members only. Additional temporary and permanent bracing is always required for stability and to prevent collapse with possible personal injury and property damage. For general guidance regarding the fabrication, storage, delivery, erection and bracing of trusses and truss systems, see **ANSI/TPI1 Quality Criteria, DSB-89 and BCSI Building Component Safety Information** available from Truss Plate Institute, 2670 Crain Highway, Suite 203 Waldorf, MD 20601



818 Soundside Road
 Edenton, NC 27932

Job J0323-1214	Truss V2	Truss Type VALLEY	Qty 1	Ply 1	Lot 43 Liberty Meadow 156917894
-------------------	-------------	----------------------	----------	----------	------------------------------------

Comtech, Inc. Fayetteville, NC - 28314,

8.430 s Jan 6 2022 MiTek Industries, Inc. Wed Mar 1 09:55:10 2023 Page 1

ID:aTXuLo?nW09qtpROz2WQ0wydkZW-7yb6?ffl3NAZHdYsrqYlaSM7mKhayUWENovEYPzfKAV

Job Reference (optional)

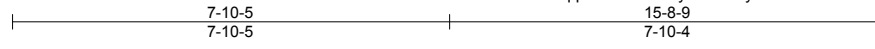

4x4 =

Scale = 1:41.4

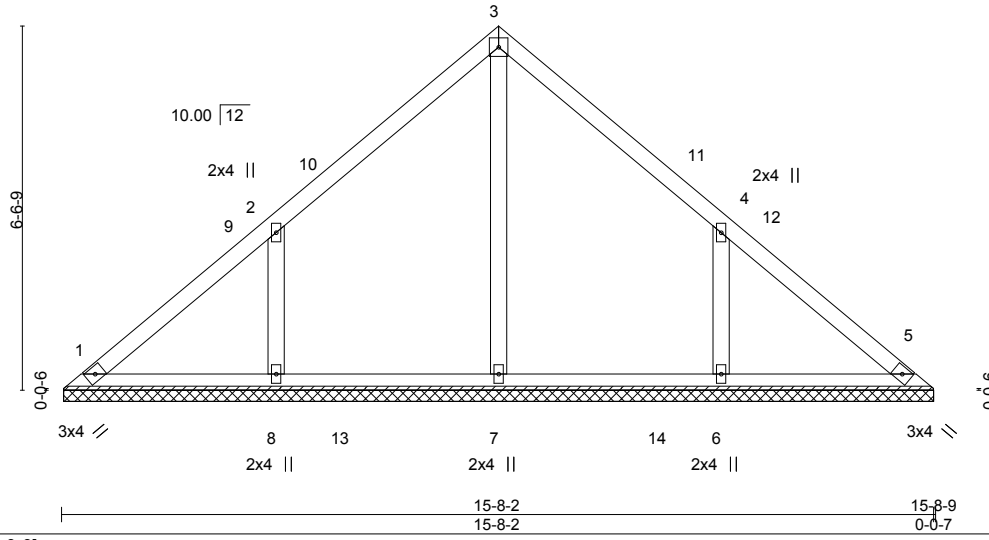

Plate Offsets (X,Y)-- [4:0-0-0,0-0-0]

LOADING (psf)	SPACING- 2-0-0	CSI.	DEFL. in (loc) l/defl L/d	PLATES	GRIP
TCLL 20.0	Plate Grip DOL 1.15	TC 0.15	Vert(LL) n/a - n/a 999	MT20	244/190
TCDL 10.0	Lumber DOL 1.15	BC 0.17	Vert(CT) n/a - n/a 999		
BCLL 0.0 *	Rep Stress Incr YES	WB 0.10	Horz(CT) 0.00 5 n/a n/a		
BCDL 10.0	Code IRC2015/TPI2014	Matrix-S		Weight: 69 lb	FT = 20%

LUMBER-
 TOP CHORD 2x4 SP No.1
 BOT CHORD 2x4 SP No.1
 OTHERS 2x4 SP No.2

BRACING-
 TOP CHORD Structural wood sheathing directly applied or 6-0-0 oc purlins.
 BOT CHORD Rigid ceiling directly applied or 10-0-0 oc bracing.

REACTIONS. All bearings 15-7-11.
 (lb) - Max Horz 1=-149(LC 8)
 Max Uplift All uplift 100 lb or less at joint(s) 1 except 8=-143(LC 12), 6=-142(LC 13)
 Max Grav All reactions 250 lb or less at joint(s) 1, 5 except 7=411(LC 19), 8=429(LC 19), 6=429(LC 20)

FORCES. (lb) - Max. Comp./Max. Ten. - All forces 250 (lb) or less except when shown.
 WEBS 2-8=-356/254, 4-6=-356/254

- NOTES-**
- Unbalanced roof live loads have been considered for this design.
 - Wind: ASCE 7-10; Vult=130mph Vasd=103mph; TC DL=6.0psf; BCDL=6.0psf; h=15ft; Cat. II; Exp C; Enclosed; MWFRS (envelope) and C-C Exterior(2) 0-4-13 to 4-9-10, Interior(1) 4-9-10 to 7-10-5, Exterior(2) 7-10-5 to 12-3-1, Interior(1) 12-3-1 to 15-3-12 zone; C-C for members and forces & MWFRS for reactions shown; Lumber DOL=1.60 plate grip DOL=1.60
 - Gable requires continuous bottom chord bearing.
 - This truss has been designed for a 10.0 psf bottom chord live load nonconcurrent with any other live loads.
 - * This truss has been designed for a live load of 30.0psf on the bottom chord in all areas where a rectangle 3-6-0 tall by 2-0-0 wide will fit between the bottom chord and any other members, with BCDL = 10.0psf.
 - Provide mechanical connection (by others) of truss to bearing plate capable of withstanding 100 lb uplift at joint(s) 1 except (jt=lb) 8=143, 6=142.



March 1, 2023

Job J0323-1214	Truss V3	Truss Type VALLEY	Qty 1	Ply 1	Lot 43 Liberty Meadow I56917895
-------------------	-------------	----------------------	----------	----------	------------------------------------

Comtech, Inc. Fayetteville, NC - 28314,

8.430 s Jan 6 2022 MiTek Industries, Inc. Wed Mar 1 09:55:11 2023 Page 1

ID:aTXuLo?nW09qtpROz2WQ0wydkZW-b99UD?fwphiQvn73PX3X7gvlsk22hxFNcSfn5szfKAU

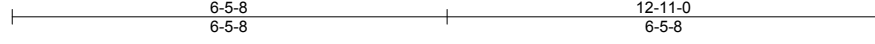

4x4 =

Scale = 1:34.2

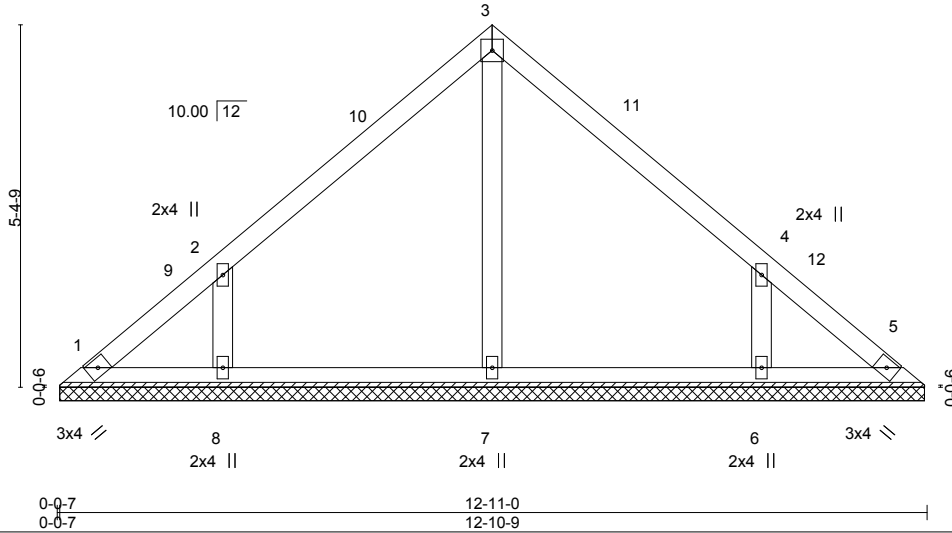

Plate Offsets (X,Y)--	[4:0-0-0,0-0-0]				
LOADING (psf)	SPACING- 2-0-0	CSI.	DEFL. in (loc) l/defl L/d	PLATES	GRIP
TCLL 20.0	Plate Grip DOL 1.15	TC 0.13	Vert(LL) n/a - n/a 999	MT20	244/190
TCDL 10.0	Lumber DOL 1.15	BC 0.09	Vert(CT) n/a - n/a 999		
BCLL 0.0 *	Rep Stress Incr YES	WB 0.07	Horz(CT) 0.00 5 n/a n/a		
BCDL 10.0	Code IRC2015/TPI2014	Matrix-S		Weight: 54 lb	FT = 20%

LUMBER-
TOP CHORD 2x4 SP No.1
BOT CHORD 2x4 SP No.1
OTHERS 2x4 SP No.2

BRACING-
TOP CHORD Structural wood sheathing directly applied or 6-0-0 oc purlins.
BOT CHORD Rigid ceiling directly applied or 10-0-0 oc bracing.

REACTIONS. All bearings 12-10-1.
(lb) - Max Horz 1=-121(LC 8)
Max Uplift All uplift 100 lb or less at joint(s) 1, 5 except 8=-124(LC 12), 6=-124(LC 13)
Max Grav All reactions 250 lb or less at joint(s) 1, 5, 7 except 8=330(LC 19), 6=330(LC 20)

FORCES. (lb) - Max. Comp./Max. Ten. - All forces 250 (lb) or less except when shown.
WEBS 2-8=-314/239, 4-6=-314/239

- NOTES-**
- 1) Unbalanced roof live loads have been considered for this design.
 - 2) Wind: ASCE 7-10; Vult=130mph Vasd=103mph; TC DL=6.0psf; BC DL=6.0psf; h=15ft; Cat. II; Exp C; Enclosed; MWFRS (envelope) and C-C Exterior(2) 0-4-13 to 4-9-10, Interior(1) 4-9-10 to 6-5-8, Exterior(2) 6-5-8 to 10-10-5, Interior(1) 10-10-5 to 12-6-3 zone; C-C for members and forces & MWFRS for reactions shown; Lumber DOL=1.60 plate grip DOL=1.60
 - 3) This truss has been designed for a 10.0 psf bottom chord live load nonconcurrent with any other live loads.
 - 4) * This truss has been designed for a live load of 30.0psf on the bottom chord in all areas where a rectangle 3-6-0 tall by 2-0-0 wide will fit between the bottom chord and any other members.
 - 5) Provide mechanical connection (by others) of truss to bearing plate capable of withstanding 100 lb uplift at joint(s) 1, 5 except (jt=lb) 8=124, 6=124.
 - 6) Non Standard bearing condition. Review required.

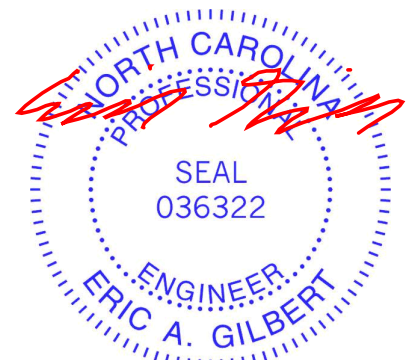

March 1, 2023

WARNING - Verify design parameters and READ NOTES ON THIS AND INCLUDED MITEK REFERENCE PAGE MII-7473 rev. 5/19/2020 BEFORE USE.
Design valid for use only with MiTek® connectors. This design is based only upon parameters shown, and is for an individual building component, not a truss system. Before use, the building designer must verify the applicability of design parameters and properly incorporate this design into the overall building design. Bracing indicated is to prevent buckling of individual truss web and/or chord members only. Additional temporary and permanent bracing is always required for stability and to prevent collapse with possible personal injury and property damage. For general guidance regarding the fabrication, storage, delivery, erection and bracing of trusses and truss systems, see **ANSI/TPI1 Quality Criteria, DSB-89 and BCSI Building Component Safety Information** available from Truss Plate Institute, 2670 Crain Highway, Suite 203 Waldorf, MD 20601



Job J0323-1214	Truss V4	Truss Type VALLEY	Qty 1	Ply 1	Lot 43 Liberty Meadow I56917896
-------------------	-------------	----------------------	----------	----------	------------------------------------

Comtech, Inc. Fayetteville, NC - 28314,

8.430 s Jan 6 2022 MiTek Industries, Inc. Wed Mar 1 09:55:13 2023 Page 1

ID:aTXuLo?nW09qtpROz2WQ0wydkZW-XXHFehhALiY885GRWY5?C5_dqYjP9szg4m8u9kzfkAS

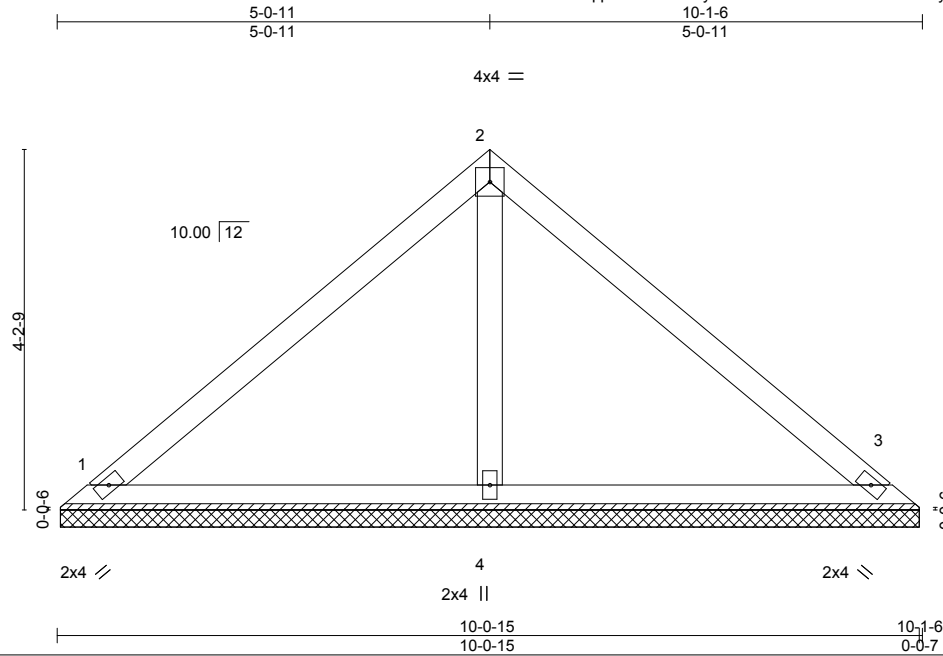

Scale = 1:26.9

LOADING (psf)	SPACING-	CSI.	DEFL.	in (loc)	l/defl	L/d	PLATES	GRIP
TCLL 20.0	2-0-0	TC 0.23	Vert(LL)	n/a	-	n/a	MT20	244/190
TCDL 10.0	Plate Grip DOL 1.15	BC 0.16	Vert(CT)	n/a	-	n/a		
BCLL 0.0 *	Lumber DOL 1.15	WB 0.06	Horz(CT)	0.00	3	n/a		
BCDL 10.0	Rep Stress Incr YES	Matrix-S					Weight: 38 lb	FT = 20%
	Code IRC2015/TPI2014							

LUMBER-
 TOP CHORD 2x4 SP No.1
 BOT CHORD 2x4 SP No.1
 OTHERS 2x4 SP No.2

BRACING-
 TOP CHORD Structural wood sheathing directly applied or 6-0-0 oc purlins.
 BOT CHORD Rigid ceiling directly applied or 10-0-0 oc bracing.

REACTIONS. (size) 1=10-0-8, 3=10-0-8, 4=10-0-8
 Max Horz 1=93(LC 11)
 Max Uplift 1=22(LC 13), 3=30(LC 13)
 Max Grav 1=199(LC 1), 3=199(LC 1), 4=347(LC 1)

FORCES. (lb) - Max. Comp./Max. Ten. - All forces 250 (lb) or less except when shown.

NOTES-

- 1) Unbalanced roof live loads have been considered for this design.
- 2) Wind: ASCE 7-10; Vult=130mph Vasd=103mph; TC DL=6.0psf; BC DL=6.0psf; h=15ft; Cat. II; Exp C; Enclosed; MWFRS (envelope) and C-C Exterior(2) zone; C-C for members and forces & MWFRS for reactions shown; Lumber DOL=1.60 plate grip DOL=1.60
- 3) Gable requires continuous bottom chord bearing.
- 4) This truss has been designed for a 10.0 psf bottom chord live load nonconcurrent with any other live loads.
- 5) * This truss has been designed for a live load of 30.0psf on the bottom chord in all areas where a rectangle 3-6-0 tall by 2-0-0 wide will fit between the bottom chord and any other members.
- 6) Provide mechanical connection (by others) of truss to bearing plate capable of withstanding 100 lb uplift at joint(s) 1, 3.

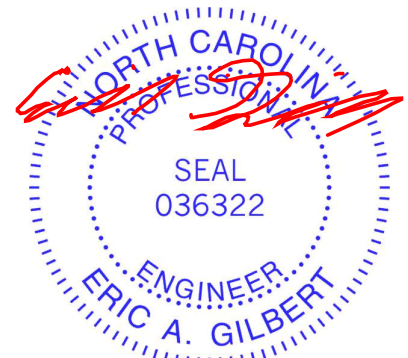

March 1, 2023

WARNING - Verify design parameters and READ NOTES ON THIS AND INCLUDED MITEK REFERENCE PAGE MII-7473 rev. 5/19/2020 BEFORE USE.

Design valid for use only with MiTek® connectors. This design is based only upon parameters shown, and is for an individual building component, not a truss system. Before use, the building designer must verify the applicability of design parameters and properly incorporate this design into the overall building design. Bracing indicated is to prevent buckling of individual truss web and/or chord members only. Additional temporary and permanent bracing is always required for stability and to prevent collapse with possible personal injury and property damage. For general guidance regarding the fabrication, storage, delivery, erection and bracing of trusses and truss systems, see **ANSI/TPI1 Quality Criteria, DSB-89 and BCSI Building Component Safety Information** available from Truss Plate Institute, 2670 Crain Highway, Suite 203 Waldorf, MD 20601



818 Soundside Road
 Edenton, NC 27932

Job J0323-1214	Truss V5	Truss Type VALLEY	Qty 1	Ply 1	Lot 43 Liberty Meadow I56917897
-------------------	-------------	----------------------	----------	----------	------------------------------------

Comtech, Inc. Fayetteville, NC - 28314,

8.430 s Jan 6 2022 MiTek Industries, Inc. Wed Mar 1 09:55:14 2023 Page 1
ID:aTXuLo?nW09qtpROz2WQ0wydkZW-0jqdr1io6cg?mFre4fcEkIxpjx4vuJlPlPtRiBzfkAR

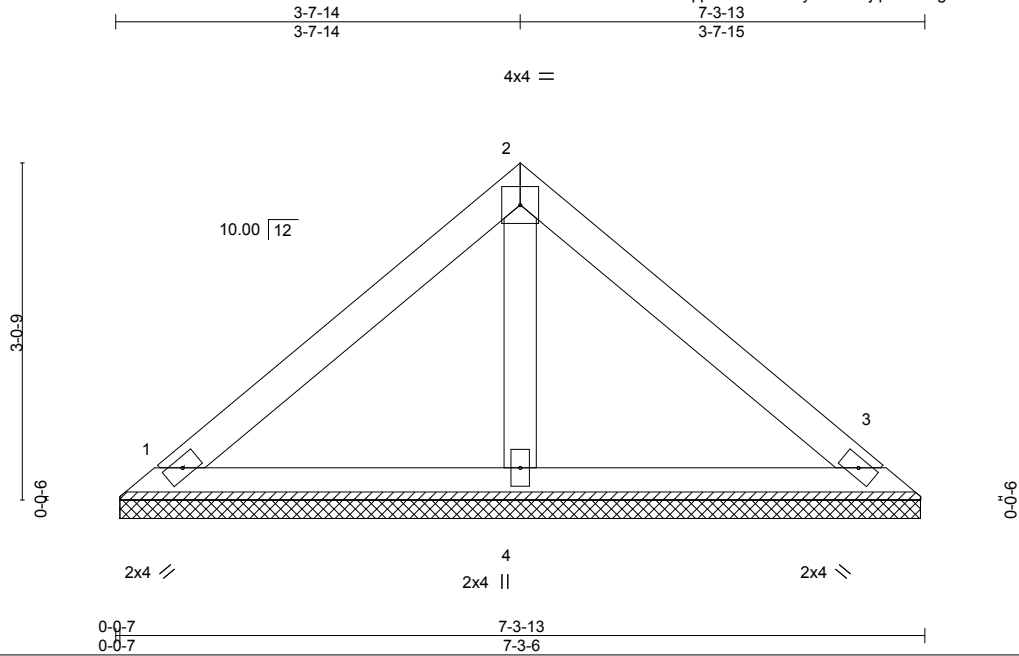

Scale = 1:20.8

LOADING (psf)	SPACING-	CSI.	DEFL.	in (loc)	l/defl	L/d	PLATES	GRIP
TCLL 20.0	2-0-0	TC 0.15	Vert(LL)	n/a	-	n/a	MT20	244/190
TCDL 10.0	Plate Grip DOL 1.15	BC 0.08	Vert(CT)	n/a	-	n/a		
BCLL 0.0 *	Lumber DOL 1.15	WB 0.02	Horz(CT)	0.00	3	n/a		
BCDL 10.0	Rep Stress Incr YES	Matrix-P					Weight: 27 lb	FT = 20%
	Code IRC2015/TPI2014							

LUMBER-
TOP CHORD 2x4 SP No.1
BOT CHORD 2x4 SP No.1
OTHERS 2x4 SP No.2

BRACING-
TOP CHORD Structural wood sheathing directly applied or 6-0-0 oc purlins.
BOT CHORD Rigid ceiling directly applied or 10-0-0 oc bracing.

REACTIONS. (size) 1=7-2-14, 3=7-2-14, 4=7-2-14
Max Horz 1=-65(LC 8)
Max Uplift 1=-23(LC 13), 3=-29(LC 13)
Max Grav 1=151(LC 1), 3=151(LC 1), 4=220(LC 1)

FORCES. (lb) - Max. Comp./Max. Ten. - All forces 250 (lb) or less except when shown.

NOTES-

- 1) Unbalanced roof live loads have been considered for this design.
- 2) Wind: ASCE 7-10; Vult=130mph Vasd=103mph; TCCL=6.0psf; BCDL=6.0psf; h=15ft; Cat. II; Exp C; Enclosed; MWFRS (envelope) and C-C Exterior(2) zone; C-C for members and forces & MWFRS for reactions shown; Lumber DOL=1.60 plate grip DOL=1.60
- 3) This truss has been designed for a 10.0 psf bottom chord live load nonconcurrent with any other live loads.
- 4) * This truss has been designed for a live load of 30.0psf on the bottom chord in all areas where a rectangle 3-6-0 tall by 2-0-0 wide will fit between the bottom chord and any other members.
- 5) Provide mechanical connection (by others) of truss to bearing plate capable of withstanding 100 lb uplift at joint(s) 1, 3.
- 6) Non Standard bearing condition. Review required.



March 1, 2023

WARNING - Verify design parameters and READ NOTES ON THIS AND INCLUDED MITEK REFERENCE PAGE MII-7473 rev. 5/19/2020 BEFORE USE.

Design valid for use only with MiTek® connectors. This design is based only upon parameters shown, and is for an individual building component, not a truss system. Before use, the building designer must verify the applicability of design parameters and properly incorporate this design into the overall building design. Bracing indicated is to prevent buckling of individual truss web and/or chord members only. Additional temporary and permanent bracing is always required for stability and to prevent collapse with possible personal injury and property damage. For general guidance regarding the fabrication, storage, delivery, erection and bracing of trusses and truss systems, see

ANSI/TPI1 Quality Criteria, DSB-89 and BCSI Building Component

Safety Information available from Truss Plate Institute, 2670 Crain Highway, Suite 203 Waldorf, MD 20601



818 Soundside Road
Edenton, NC 27932

Job J0323-1214	Truss V6	Truss Type VALLEY	Qty 1	Ply 1	Lot 43 Liberty Meadow I56917898
-------------------	-------------	----------------------	----------	----------	------------------------------------

Comtech, Inc. Fayetteville, NC - 28314,

8.430 s Jan 6 2022 MiTek Industries, Inc. Wed Mar 1 09:55:16 2023 Page 1

ID:aTXuLo?nW09qtpROz2WQ0wydkZW-y6yNGjj2eDxj?Y?0B4fjqcBulmCMDQ6mjMYm3zfkKAP

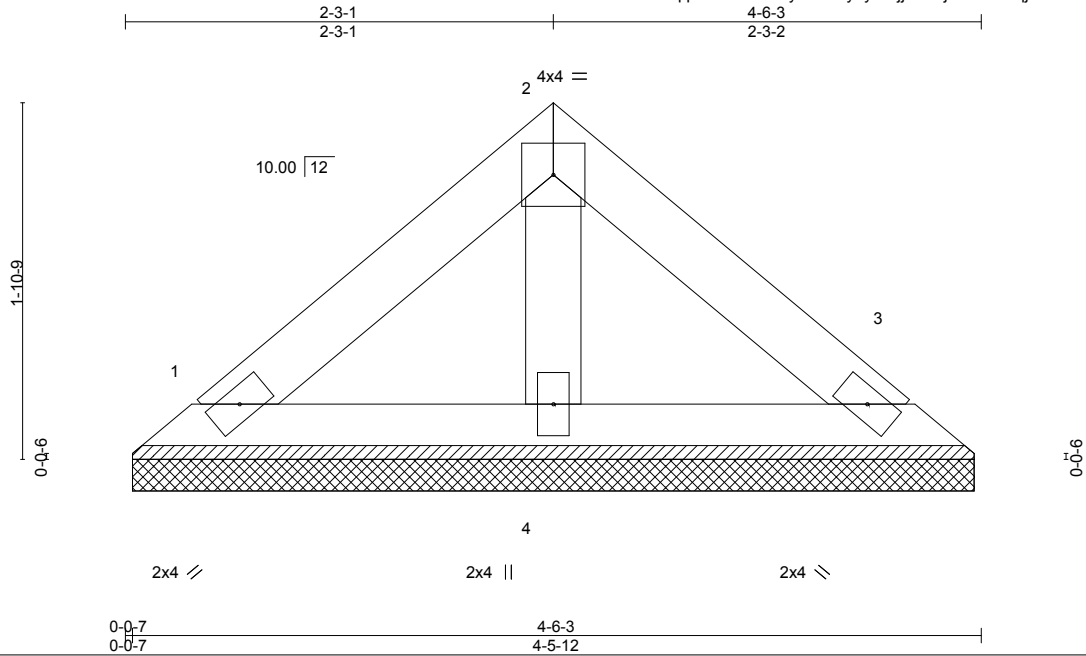

Scale = 1:12.2

LOADING (psf)	SPACING-	CSI.	DEFL.	in (loc)	l/defl	L/d	PLATES	GRIP
TCLL 20.0	2-0-0	TC 0.05	Vert(LL)	n/a	-	n/a	MT20	244/190
TCDL 10.0	Plate Grip DOL 1.15	BC 0.03	Vert(CT)	n/a	-	n/a		
BCLL 0.0 *	Lumber DOL 1.15	WB 0.01	Horz(CT)	0.00	3	n/a		
BCDL 10.0	Rep Stress Incr YES	Matrix-P					Weight: 16 lb	FT = 20%
	Code IRC2015/TPI2014							

LUMBER-
 TOP CHORD 2x4 SP No.1
 BOT CHORD 2x4 SP No.1
 OTHERS 2x4 SP No.2

BRACING-
 TOP CHORD Structural wood sheathing directly applied or 4-6-3 oc purlins.
 BOT CHORD Rigid ceiling directly applied or 10-0-0 oc bracing.

REACTIONS. (size) 1=4-5-5, 3=4-5-5, 4=4-5-5
 Max Horz 1=37(LC 8)
 Max Uplift 1=13(LC 13), 3=16(LC 13)
 Max Grav 1=86(LC 1), 3=86(LC 1), 4=125(LC 1)

FORCES. (lb) - Max. Comp./Max. Ten. - All forces 250 (lb) or less except when shown.

NOTES-

- 1) Unbalanced roof live loads have been considered for this design.
- 2) Wind: ASCE 7-10; Vult=130mph Vasd=103mph; TC DL=6.0psf; BCDL=6.0psf; h=15ft; Cat. II; Exp C; Enclosed; MWFRS (envelope) and C-C Exterior(2) zone; C-C for members and forces & MWFRS for reactions shown; Lumber DOL=1.60 plate grip DOL=1.60
- 3) Gable requires continuous bottom chord bearing.
- 4) This truss has been designed for a 10.0 psf bottom chord live load nonconcurrent with any other live loads.
- 5) * This truss has been designed for a live load of 30.0psf on the bottom chord in all areas where a rectangle 3-6-0 tall by 2-0-0 wide will fit between the bottom chord and any other members.
- 6) Provide mechanical connection (by others) of truss to bearing plate capable of withstanding 100 lb uplift at joint(s) 1, 3.

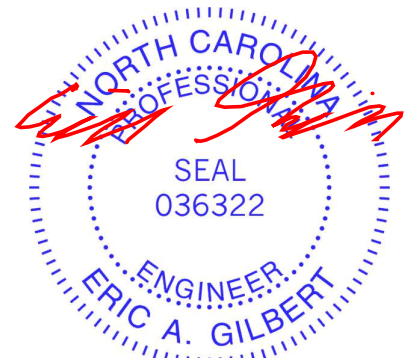

March 1, 2023

WARNING - Verify design parameters and READ NOTES ON THIS AND INCLUDED MITEK REFERENCE PAGE MII-7473 rev. 5/19/2020 BEFORE USE.

Design valid for use only with MiTek® connectors. This design is based only upon parameters shown, and is for an individual building component, not a truss system. Before use, the building designer must verify the applicability of design parameters and properly incorporate this design into the overall building design. Bracing indicated is to prevent buckling of individual truss web and/or chord members only. Additional temporary and permanent bracing is always required for stability and to prevent collapse with possible personal injury and property damage. For general guidance regarding the fabrication, storage, delivery, erection and bracing of trusses and truss systems, see

ANSI/TPI1 Quality Criteria, DSB-89 and BCSI Building Component

Safety Information available from Truss Plate Institute, 2670 Crain Highway, Suite 203 Waldorf, MD 20601



818 Soundside Road
 Edenton, NC 27932

Symbols

PLATE LOCATION AND ORIENTATION

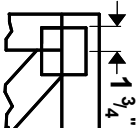

Center plate on joint unless x, y offsets are indicated. Dimensions are in ft-in-sixteenths. Apply plates to both sides of truss and fully embed teeth.

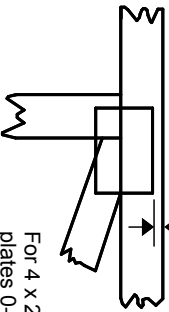

For 4 x 2 orientation, locate plates 0- $\frac{1}{16}$ " from outside edge of truss.



This symbol indicates the required direction of slots in connector plates.

* Plate location details available in **MITek 20/20 software** or upon request.

PLATE SIZE

4 X 4

The first dimension is the plate width measured perpendicular to slots. Second dimension is the length parallel to slots.

LATERAL BRACING LOCATION



Indicated by symbol shown and/or by text in the bracing section of the output. Use T or I bracing if indicated.

BEARING



Indicates location where bearings (supports) occur. Icons vary but reaction section indicates joint number where bearings occur. Min size shown is for crushing only.

Industry Standards:

ANSI/TFP 1: National Design Specification for Metal Plate Connected Wood Truss Construction.
DSB-89: Design Standard for Bracing.
BCSI: Building Component Safety Information, Guide to Good Practice for Handling, Installing & Bracing of Metal Plate Connected Wood Trusses.

Numbering System

6-4-8
dimensions shown in ft-in-sixteenths
(Drawings not to scale)

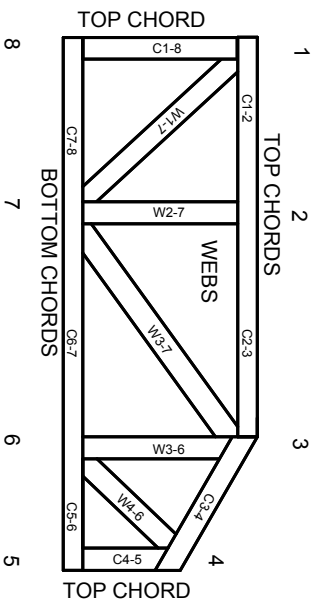

JOINTS ARE GENERALLY NUMBERED/LETTERED CLOCKWISE AROUND THE TRUSS STARTING AT THE JOINT FARTHEST TO THE LEFT.

CHORDS AND WEBS ARE IDENTIFIED BY END JOINT NUMBERS/LETTERS.

PRODUCT CODE APPROVALS

ICC-ES Reports:

ESR-1311, ESR-1352, ESR1988
ER-3907, ESR-2362, ESR-1397, ESR-3282

Trusses are designed for wind loads in the plane of the truss unless otherwise shown.

Lumber design values are in accordance with ANSI/TFP 1 section 6.3 These truss designs rely on lumber values established by others.

© 2012 MITteK® All Rights Reserved



MITek Engineering Reference Sheet: Mill-7473 rev. 5/19/2020



General Safety Notes

Failure to Follow Could Cause Property Damage or Personal Injury

1. Additional stability bracing for truss system, e.g. diagonal or X-bracing, is always required. See BCSI.
2. Truss bracing must be designed by an engineer. For wide truss spacing, individual lateral braces themselves may require bracing, or alternative Tor I bracing should be considered.
3. Never exceed the design loading shown and never stack materials on inadequately braced trusses.
4. Provide copies of this truss design to the building designer, erection supervisor, property owner and all other interested parties.
5. Cut members to bear tightly against each other.
6. Place plates on each face of truss at each joint and embed fully. Knots and wane at joint locations are regulated by ANSI/TFP 1.
7. Design assumes trusses will be suitably protected from the environment in accord with ANSI/TFP 1.
8. Unless otherwise noted, moisture content of lumber shall not exceed 19% at time of fabrication.
9. Unless expressly noted, this design is not applicable for use with fire retardant, preservative treated, or green lumber.
10. Camber is a non-structural consideration and is the responsibility of truss fabricator. General practice is to camber for dead load deflection.
11. Plate type, size, orientation and location dimensions indicated are minimum plating requirements.
12. Lumber used shall be of the species and size, and in all respects, equal to or better than that specified.
13. Top chords must be sheathed or purlins provided at spacing indicated on design.
14. Bottom chords require lateral bracing at 10 ft. spacing, or less, if no ceiling is installed, unless otherwise noted.
15. Connections not shown are the responsibility of others.
16. Do not cut or alter truss member or plate without prior approval of an engineer.
17. Install and load vertically unless indicated otherwise.
18. Use of green or treated lumber may pose unacceptable environmental, health or performance risks. Consult with project engineer before use.
19. Review all portions of this design (front, back, words and pictures) before use. Reviewing pictures alone is not sufficient.
20. Design assumes manufacture in accordance with ANSI/TFP 1 Quality Criteria.
21. The design does not take into account any dynamic or other loads other than those expressly stated.

Reaction Summary of Order



REQ. QUOTE DATE	/ /	ORDER #	J0323-1215
ORDER DATE	03/16/23	QUOTE #	
DELIVERY DATE	/ /	CUSTOMER ACCT #	0000007216
DATE OF INVOICE	/ /	CUSTOMER PO #	
ORDERED BY	Shaun Garderner	INVOICE #	
COUNTY	Harnett	TERMS	
SUPERINTENDANT	Shaun Garderner	SALES REP	Neil Baggett
JOBSITE PHONE #	(910) 988-8172	SALES AREA	David Landry

SOLD TO	Precision Custom Homes 256 Briar Hill Rd. Raeford, NC 28376 (910) 988-8172	JOB NAME: Lot 43 Liberty Meadow MODEL: Floor TAG: Liberty 2.0 w/ CP DELIVERY INSTRUCTIONS: 52 miles round trip	LOT # 43 SUBDIV: Liberty Meadow JOB CATEGORY: _
	Precision Custom Homes and Lot 43 Liberty Meadow Cameron, NC 28356	SPECIAL INSTRUCTIONS: Like 38 Liberty Meadows	PLAN SEAL DATE: BY DATE

BUILDING DEPARTMENT Floor Order	OVERHANG INFO	HEEL HEIGHT	00-06-08	REQ. LAYOUTS	REQ. ENGINEERING	QUOTE	DTL	03/17/23
	END CUT	RETURN				LAYOUT	DTL	03/21/23
	GABLE STUDS		24 IN. OC		JOBSITE 1	JOBSITE 1	CUTTING	DTL

FLOOR TRUSSES	LOADING INFORMATION	TCLL-TCDL-BCLL-BCDL	STRESS INCR.	FLOOR TRUSS SPACING: 24.0 IN. O.C. (TYP.)
		40.0,10.0,0.0,5.0	1.00	

FLOOR PROFILE	QTY PLY	DEPTH ID	BASE SPAN	O/A SPAN	END TYPE		INT BEARING		REACTIONS				
					LEFT	RIGHT	SIZE	LOCATION					
	1	01-04-00 ET1	32-11-00	32-11-00					Joint 29 23.4 lbs.	Joint 30 127.1 lbs.	Joint 31 151.2 lbs.	Joint 32 145.5 lbs.	Joint 33 147.0 lbs.
	1	01-04-00 ET2	18-04-00	18-04-00					Joint 17 32.7 lbs.	Joint 18 134.3 lbs.	Joint 19 150.0 lbs.	Joint 20 145.8 lbs.	Joint 21 146.9 lbs.
	1	01-04-00 ET3	19-04-08	19-04-08					Joint 18 35.3 lbs.	Joint 19 136.7 lbs.	Joint 20 149.5 lbs.	Joint 21 145.9 lbs.	Joint 22 146.9 lbs.
	7	01-04-00 F1	32-11-00	32-11-00					Joint 24 882.3 lbs. 204.1 lbs.	Joint 33 2190.2 lbs. 1224.3 lbs.	Joint 40 662.4 lbs. 22.2 lbs.		
	3	01-04-00 F2	31-11-00	31-11-00					Joint 22 794.9 lbs. 131.6 lbs.	Joint 30 2078.8 lbs. 1319.8 lbs.	Joint 36 719.4 lbs. 127.0 lbs.		
	9	01-04-00 F3	19-11-00	19-11-00					Joint 14 1075.4 lbs. 522.5 lbs.	Joint 24 1075.4 lbs. 522.5 lbs.			
	10	01-04-00 F4	19-08-00	19-08-00					Joint 16 1067.9 lbs. 512.1 lbs.	Joint 25 1061.7 lbs. 567.4 lbs.			
	1	01-04-00 F4A	19-08-00	19-08-00					Joint 16 275.1 lbs. 3.8 lbs.	Joint 20 1157.1 lbs. 526.1 lbs.	Joint 31 730.4 lbs. 198.6 lbs.		
	1	01-04-00 F5	05-10-08	05-10-08					Joint 4 294.4 lbs. 198.6 lbs.	Joint 8 288.3 lbs. 193.7 lbs.			

Reaction Summary of Order



ROOF & FLOOR TRUSSES & BEAMS
 Reilly Road Industrial Park P.O. Box 40408
 Fayetteville, N.C. 28309 (910) 864-TRUS

REQ. QUOTE DATE	/ /	ORDER #	J0323-1215
ORDER DATE	03/16/23	QUOTE #	
DELIVERY DATE	/ /	CUSTOMER ACCT #	0000007216
DATE OF INVOICE	/ /	CUSTOMER PO #	
ORDERED BY	Shaun Garderner	INVOICE #	
COUNTY	Harnett	TERMS	
SUPERINTENDANT	Shaun Garderner	SALES REP	Neil Baggett
JOBSITE PHONE #	(910) 988-8172	SALES AREA	David Landry

SOLD TO	Precision Custom Homes 256 Briar Hill Rd. Raeford, NC 28376 (910) 988-8172	JOB NAME: Lot 43 Liberty Meadow MODEL: Floor TAG: Liberty 2.0 w/ CP DELIVERY INSTRUCTIONS: 52 miles round trip	LOT # 43 SUBDIV: Liberty Meadow JOB CATEGORY: _
	SHIPPED TO	Precision Custom Homes and Lot 43 Liberty Meadow Cameron, NC 28356	SPECIAL INSTRUCTIONS: Like 38 Liberty Meadows

BUILDING DEPARTMENT Floor Order	OVERHANG INFO	HEEL HEIGHT	00-06-08	REQ. LAYOUTS	REQ. ENGINEERING	QUOTE	DTL	03/17/23
	END CUT	RETURN				LAYOUT	DTL	03/21/23
	GABLE STUDS		24 IN. OC		JOBSITE 1	JOBSITE 1	CUTTING	DTL

FLOOR TRUSSES	LOADING INFORMATION	TCLL-TCDL-BCLL-BCDL	STRESS INCR.	FLOOR TRUSS SPACING: 24.0 IN. O.C. (TYP.)
		40.0,10.0,0.0,5.0	1.00	

FLOOR PROFILE	QTY PLY	DEPTH ID	BASE SPAN	O/A SPAN	END TYPE		INT BEARING		REACTIONS
					LEFT	RIGHT	SIZE	LOCATION	

	1	01-01-00 FG1	05-06-00	05-06-00					Joint 5 478.3 lbs. 414.3 lbs.	Joint 8 456.2 lbs. 377.0 lbs.
---	---	-----------------	----------	----------	---	---	--	--	-------------------------------------	-------------------------------------

ITEMS

QTY	ITEM TYPE	SIZE	LENGTH FT-IN-16	PART NUMBER	NOTES
8	Hangers, USP	HUS 410			SIMPSON (HUS410)
2	LVL Beams (Sized)	LVL, 1-3/4" x 9-1/4" (S)	07-00-00		BM4
2	LVL Beams (Sized)	LVL, 1-3/4" x 11-7/8" (S)	09-00-00		BM5
2	LVL Beams (Sized)	LVL, 1-3/4" x 11-7/8" (S)	20-00-00		GDH
2	LVL Beams (Sized)	LVL, 1-3/4" x 16" (S)	17-00-00		BM1
2	LVL Beams (Sized)	LVL, 1-3/4" x 16" (S)	20-00-00		BM2

BM1 Kerto-S LVL 1.750" X 16.000" 2-Ply - PASSED

Level: Level

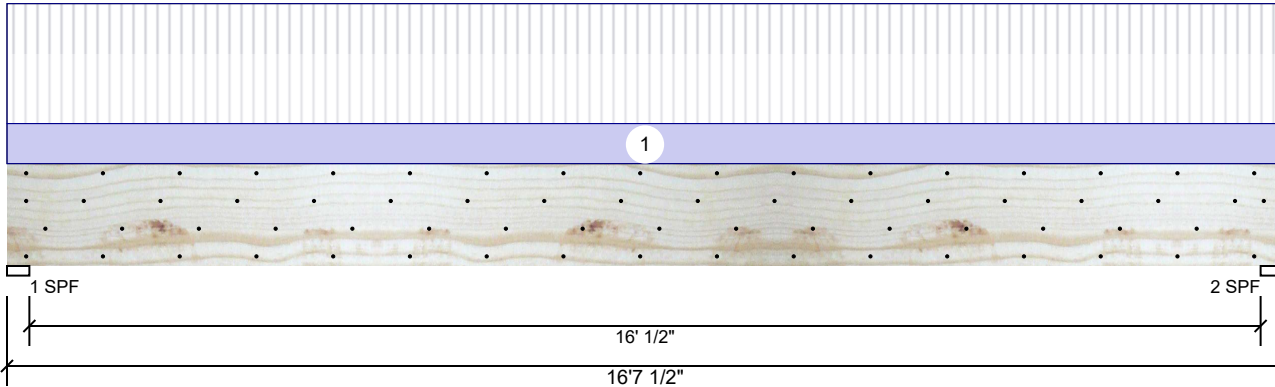

Member Information

Type:	Girder
Plies:	2
Moisture Condition:	Dry
Deflection LL:	480
Deflection TL:	240
Importance:	Normal - II
Temperature:	Temp <= 100°F

Application:	Floor
Design Method:	ASD
Building Code:	IBC 2012
Load Sharing:	No
Deck:	Not Checked

Reactions UNPATTERNED lb (Uplift)

Brg	Direction	Live	Dead	Snow	Wind	Const
1	Vertical	3333	1217	0	0	0
2	Vertical	3333	1217	0	0	0

Bearings

Bearing	Length	Dir.	Cap.	React D/L lb	Total	Ld. Case	Ld. Comb.
1 - SPF	3.500"	Vert	87%	1217 / 3333	4551	L	D+L
2 - SPF	3.500"	Vert	87%	1217 / 3333	4551	L	D+L

Analysis Results

Analysis	Actual	Location	Allowed	Capacity	Comb.	Case
Moment	17931 ft-lb	8'3 3/4"	34565 ft-lb	0.519 (52%)	D+L	L
Unbraced	17931 ft-lb	8'3 3/4"	17951 ft-lb	0.999 (100%)	D+L	L
Shear	4391 lb	15'	11947 lb	0.368 (37%)	D+L	L
LL Defl inch	0.286 (L/678)	8'3 13/16"	0.405 (L/480)	0.707 (71%)	L	L
TL Defl inch	0.391 (L/497)	8'3 13/16"	0.809 (L/240)	0.483 (48%)	D+L	L

Design Notes

- Provide support to prevent lateral movement and rotation at the end bearings. Lateral support may also be required at the interior bearings by the building code.
- Fasten all plies using 4 rows of 10d Box nails (.128x3") at 12" o.c. Maximum end distance not to exceed 6".
- Refer to last page of calculations for fasteners required for specified loads.
- Girders are designed to be supported on the bottom edge only.
- Top must be laterally braced at a maximum of 6'5 3/4" o.c.
- Bottom must be laterally braced at end bearings.
- Lateral slenderness ratio based on single ply width.

ID	Load Type	Location	Trib Width	Side	Dead 0.9	Live 1	Snow 1.15	Wind 1.6	Const. 1.25	Comments
1	Uniform			Near Face	134 PLF	401 PLF	0 PLF	0 PLF	0 PLF	F4
	Self Weight				12 PLF					

Notes
 Calculated Structured Designs is responsible only of the structural adequacy of this component based on the design criteria and loadings shown. It is the responsibility of the customer and/or the contractor to ensure the component suitability of the intended application, and to verify the dimensions and loads.

Lumber
 1. Dry service conditions, unless noted otherwise
 2. LVL not to be treated with fire retardant or corrosive chemicals

Handling & Installation
 1. LVL beams must not be cut or drilled
 2. Refer to manufacturer's product information regarding installation requirements, multi-ply fastening details, beam strength values, and code approvals
 3. Damaged Beams must not be used
 4. Design assumes top edge is laterally restrained
 5. Provide lateral support at bearing points to avoid lateral displacement and rotation

6. For flat roofs provide proper drainage to prevent ponding

This design is valid until 11/3/2024

Manufacturer Info

Metsä Wood
 301 Merritt 7 Building, 2nd Floor
 Norwalk, CT 06851
 (800) 622-5850
www.metsawood.com/us

Comtech, Inc.
 1001 S. Reilly Road, Suite #639
 Fayetteville, NC
 USA
 28314
 910-864-TRUS



BM1 Kerto-S LVL 1.750" X 16.000" 2-Ply - PASSED

Level: Level

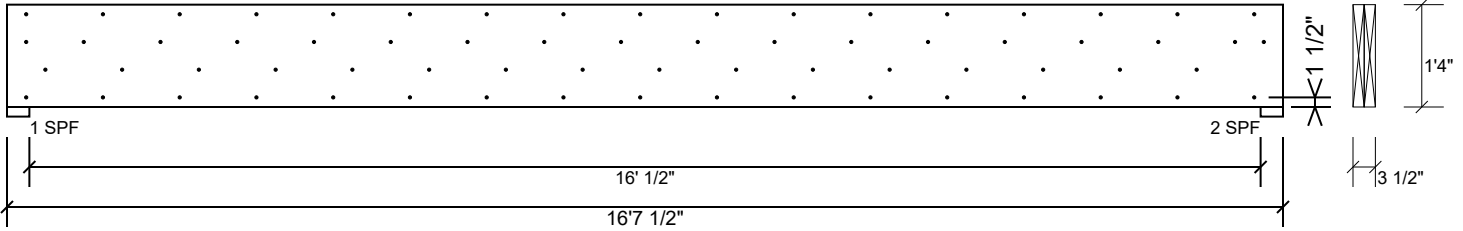

Multi-Ply Analysis

Fasten all plies using 4 rows of 10d Box nails (.128x3") at 12" o.c.. Maximum end distance not to exceed 6".

Capacity	81.7 %
Load	267.5 PLF
Yield Limit per Foot	327.4 PLF
Yield Limit per Fastener	81.9 lb.
Yield Mode	IV
Edge Distance	1 1/2"
Min. End Distance	3"
Load Combination	D+L
Duration Factor	1.00

Notes

Calculated Structured Designs is responsible only of the structural adequacy of this component based on the design criteria and loadings shown. It is the responsibility of the customer and/or the contractor to ensure the component suitability of the intended application, and to verify the dimensions and loads.

Lumber

1. Dry service conditions, unless noted otherwise
2. LVL not to be treated with fire retardant or corrosive

chemicals

Handling & Installation

1. LVL beams must not be cut or drilled
2. Refer to manufacturer's product information regarding installation requirements, multi-ply fastening details, beam strength values, and code approvals
3. Damaged Beams must not be used
4. Design assumes top edge is laterally restrained
5. Provide lateral support at bearing points to avoid lateral displacement and rotation

6. For flat roofs provide proper drainage to prevent ponding

This design is valid until 11/3/2024

Manufacturer Info

Metsä Wood
 301 Merritt 7 Building, 2nd Floor
 Norwalk, CT 06851
 (800) 622-5850
www.metsawood.com/us

Comtech, Inc.
 1001 S. Reilly Road, Suite #639
 Fayetteville, NC
 USA
 28314
 910-864-TRUS



BM2 Kerto-S LVL 1.750" X 16.000" 2-Ply - PASSED

Level: Level

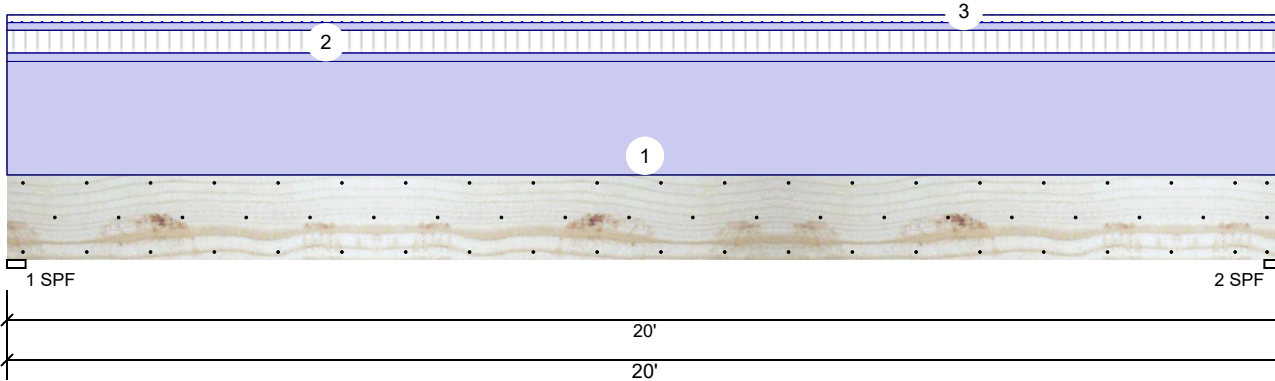

Member Information

Type:	Girder
Plies:	2
Moisture Condition:	Dry
Deflection LL:	480
Deflection TL:	240
Importance:	Normal - II
Temperature:	Temp <= 100°F

Application:	Floor
Design Method:	ASD
Building Code:	IBC 2012
Load Sharing:	No
Deck:	Not Checked

Reactions UNPATTERNED lb (Uplift)

Brg	Direction	Live	Dead	Snow	Wind	Const
1	Vertical	400	2409	135	0	0
2	Vertical	400	2409	135	0	0

Bearings

Bearing	Length	Dir.	Cap.	React D/L lb	Total	Ld. Case	Ld. Comb.
1 - SPF	3.500"	Vert	54%	2409 / 401	2811	L	D+0.75(L+S)
2 - SPF	3.500"	Vert	54%	2409 / 401	2811	L	D+0.75(L+S)

Analysis Results

Analysis	Actual	Location	Allowed	Capacity	Comb.	Case
Moment	13439 ft-lb	10'	34565 ft-lb	0.389 (39%)	D+L	L
Unbraced	13439 ft-lb	10'	13492 ft-lb	0.996 (100%)	D+L	L
Shear	2461 lb	18'4 1/2"	11947 lb	0.206 (21%)	D+L	L
LL Defl inch	0.059 (L/3960)	10' 1/16"	0.489 (L/480)	0.121 (12%)	0.75(L+S)	L
TL Defl inch	0.415 (L/565)	10' 1/16"	0.978 (L/240)	0.425 (42%)	D+0.75(L+S)	L

Design Notes

- Provide support to prevent lateral movement and rotation at the end bearings. Lateral support may also be required at the interior bearings by the building code.
- Fasten all plies using 3 rows of 10d Box nails (.128x3") at 12" o.c. Maximum end distance not to exceed 6".
- Refer to last page of calculations for fasteners required for specified loads.
- Girders are designed to be supported on the bottom edge only.
- Top loads must be supported equally by all plies.
- Top must be laterally braced at a maximum of 8'9 7/16" o.c.
- Bottom must be laterally braced at end bearings.
- Lateral slenderness ratio based on single ply width.

ID	Load Type	Location	Trib Width	Side	Dead 0.9	Live 1	Snow 1.15	Wind 1.6	Const. 1.25	Comments
1	Uniform			Top	200 PLF	0 PLF	0 PLF	0 PLF	0 PLF	Wall Above, C1GE
2	Tie-In	0-0-0 to 20-0-0	1-0-0	Far Face	15 PSF	40 PSF	0 PSF	0 PSF	0 PSF	Floor Load
3	Tie-In	0-0-0 to 20-0-0	0-6-0	Near Face	27 PSF	0 PSF	27 PSF	0 PSF	0 PSF	J3
	Self Weight				12 PLF					

Notes

Calculated Structural Designs is responsible only of the structural adequacy of this component based on the design criteria and loadings shown. It is the responsibility of the customer and/or the contractor to ensure the component suitability of the intended application, and to verify the dimensions and loads.

Lumber

- Dry service conditions, unless noted otherwise
- LVL not to be treated with fire retardant or corrosive chemicals

chemicals

Handling & Installation

- LVL beams must not be cut or drilled
- Refer to manufacturer's product information regarding installation requirements, multi-ply fastening details, beam strength values, and code approvals
- Damaged Beams must not be used
- Design assumes top edge is laterally restrained
- Provide lateral support at bearing points to avoid lateral displacement and rotation

6. For flat roofs provide proper drainage to prevent ponding

This design is valid until 11/3/2024

Manufacturer Info

Metsä Wood
 301 Merritt 7 Building, 2nd Floor
 Norwalk, CT 06851
 (800) 622-5850
www.metsawood.com/us

Comtech, Inc.
 1001 S. Reilly Road, Suite #639
 Fayetteville, NC
 USA
 28314
 910-864-TRUS



BM2 Kerto-S LVL 1.750" X 16.000" 2-Ply - PASSED

Level: Level

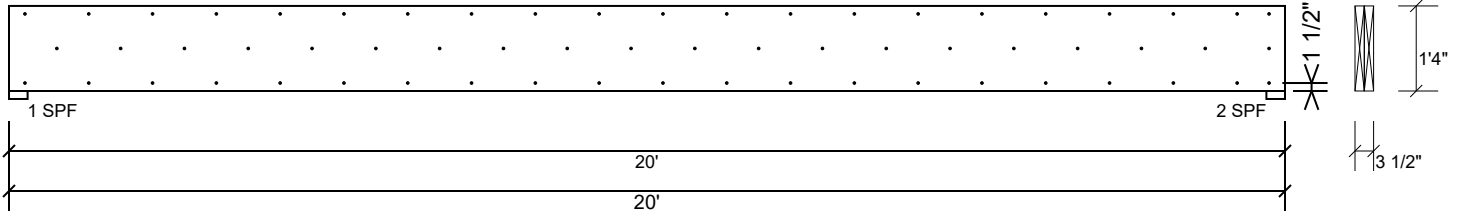

Multi-Ply Analysis

Fasten all plies using 3 rows of 10d Box nails (.128x3") at 12" o.c.. Maximum end distance not to exceed 6".

Capacity	11.2 %
Load	27.5 PLF
Yield Limit per Foot	245.6 PLF
Yield Limit per Fastener	81.9 lb.
Yield Mode	IV
Edge Distance	1 1/2"
Min. End Distance	3"
Load Combination	D+L
Duration Factor	1.00

Notes

Calculated Structured Designs is responsible only of the structural adequacy of this component based on the design criteria and loadings shown. It is the responsibility of the customer and/or the contractor to ensure the component suitability of the intended application, and to verify the dimensions and loads.

Lumber

1. Dry service conditions, unless noted otherwise
2. LVL not to be treated with fire retardant or corrosive chemicals

Handling & Installation

1. LVL beams must not be cut or drilled
2. Refer to manufacturer's product information regarding installation requirements, multi-ply fastening details, beam strength values, and code approvals
3. Damaged Beams must not be used
4. Design assumes top edge is laterally restrained
5. Provide lateral support at bearing points to avoid lateral displacement and rotation

6. For flat roofs provide proper drainage to prevent ponding

This design is valid until 11/3/2024

Manufacturer Info

Metsä Wood
 301 Merritt 7 Building, 2nd Floor
 Norwalk, CT 06851
 (800) 622-5850
www.metsawood.com/us

Comtech, Inc.
 1001 S. Reilly Road, Suite #639
 Fayetteville, NC
 USA
 28314
 910-864-TRUS



BM3 S-P-F #2 2.000" X 10.000" 2-Ply - PASSED

Level: Level

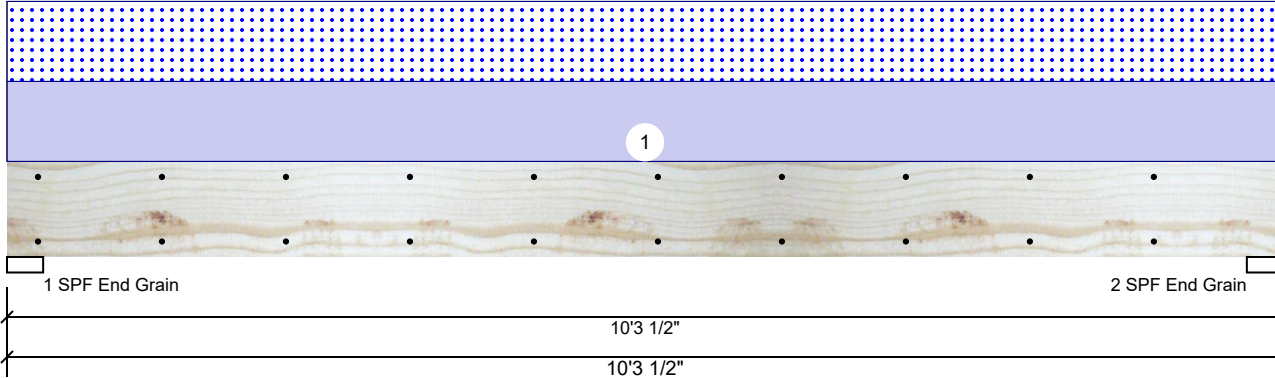

Member Information

Type:	Girder	Application:	Floor
Plies:	2	Design Method:	ASD
Moisture Condition:	Dry	Building Code:	IBC 2012
Deflection LL:	480	Load Sharing:	No
Deflection TL:	360	Deck:	Not Checked
Importance:	Normal - II	Ceiling:	Gypsum 1/2"
Temperature:	Temp <= 100°F		

Reactions UNPATTERNED lb (Uplift)

Brg	Direction	Live	Dead	Snow	Wind	Const
1	Vertical	0	607	607	0	0
2	Vertical	0	607	607	0	0

Bearings

Bearing	Length	Dir.	Cap.	React D/L lb	Total	Ld. Case	Ld. Comb.
1 - SPF End Grain	3.500"	Vert	27%	607 / 607	1214	L	D+S
2 - SPF End Grain	3.500"	Vert	27%	607 / 607	1214	L	D+S

Analysis Results

Analysis	Actual	Location	Allowed	Capacity	Comb.	Case
Moment	2852 ft-lb	5'1 3/4"	3946 ft-lb	0.723 (72%)	D+S	L
Unbraced	2852 ft-lb	5'1 3/4"	2937 ft-lb	0.971 (97%)	D+S	L
Shear	964 lb	1' 3/4"	2872 lb	0.336 (34%)	D+S	L
LL Defl inch	0.090 (L/1317)	5'1 3/4"	0.246 (L/480)	0.365 (36%)	S	L
TL Defl inch	0.179 (L/658)	5'1 3/4"	0.328 (L/360)	0.547 (55%)	D+S	L

Design Notes

- 1 Provide support to prevent lateral movement and rotation at the end bearings. Lateral support may also be required at the interior bearings by the building code.
- 2 Fasten all plies using 2 rows of 10d Box nails (.128x3") at 12" o.c. Maximum end distance not to exceed 6".
- 3 Refer to last page of calculations for fasteners required for specified loads.
- 4 Girders are designed to be supported on the bottom edge only.
- 5 Top loads must be supported equally by all plies.
- 6 Top must be laterally braced at end bearings.
- 7 Lateral slenderness ratio based on single ply width.

ID	Load Type	Location	Trib Width	Side	Dead 0.9	Live 1	Snow 1.15	Wind 1.6	Const. 1.25	Comments
1	Uniform			Top	118 PLF	0 PLF	118 PLF	0 PLF	0 PLF	B2

Manufacturer Info

Comtech, Inc.
 1001 S. Reilly Road, Suite #639
 Fayetteville, NC
 USA
 28314
 910-864-TRUS



This design is valid until 11/3/2024

BM3 S-P-F #2 2.000" X 10.000" 2-Ply - PASSED

Level: Level

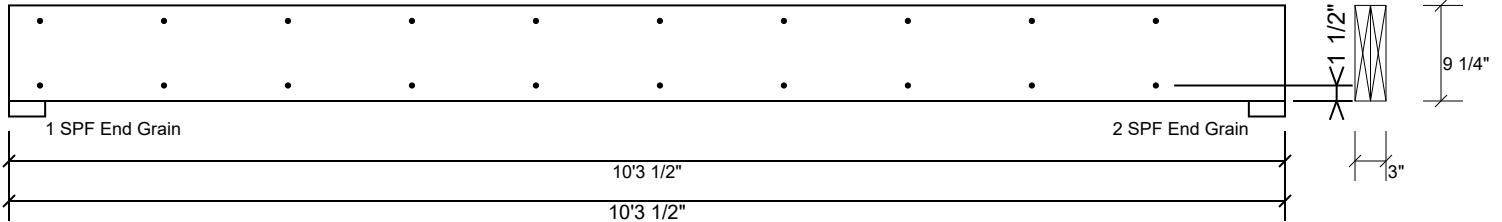

Multi-Ply Analysis

Fasten all plies using 2 rows of 10d Box nails (.128x3") at 12" o.c.. Maximum end distance not to exceed 6".

Capacity	0.0 %
Load	0.0 PLF
Yield Limit per Foot	157.4 PLF
Yield Limit per Fastener	78.7 lb.
Yield Mode	IV
Edge Distance	1 1/2"
Min. End Distance	3"
Load Combination	
Duration Factor	1.00

Manufacturer Info

Comtech, Inc.
 1001 S. Reilly Road, Suite #639
 Fayetteville, NC
 USA
 28314
 910-864-TRUS



This design is valid until 11/3/2024

BM4 Kerto-S LVL 1.750" X 9.250" 2-Ply - PASSED

Level: Level

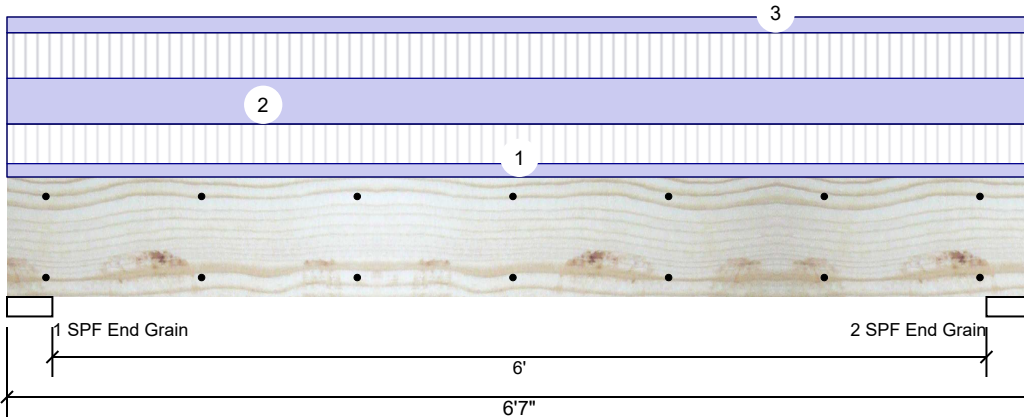

Member Information

Type:	Girder	Application:	Floor
Plies:	2	Design Method:	ASD
Moisture Condition:	Dry	Building Code:	IBC 2012
Deflection LL:	480	Load Sharing:	No
Deflection TL:	360	Deck:	Not Checked
Importance:	Normal - II		
Temperature:	Temp <= 100°F		

Reactions UNPATTERNED lb (Uplift)

Brg	Direction	Live	Dead	Snow	Wind	Const
1	Vertical	2149	1903	0	0	0
2	Vertical	2149	1903	0	0	0

Bearings

Bearing	Length	Dir.	Cap.	React D/L lb	Total	Ld. Case	Ld. Comb.
1 - SPF End Grain	3.500"	Vert	39%	1903 / 2149	4053	L	D+L
2 - SPF End Grain	3.500"	Vert	39%	1903 / 2149	4053	L	D+L

Analysis Results

Analysis	Actual	Location	Allowed	Capacity	Comb.	Case
Moment	5774 ft-lb	3'3 1/2"	12542 ft-lb	0.460 (46%)	D+L	L
Unbraced	5774 ft-lb	3'3 1/2"	9934 ft-lb	0.581 (58%)	D+L	L
Shear	2750 lb	1'3/4"	6907 lb	0.398 (40%)	D+L	L
LL Defl inch	0.056 (L/1320)	3'3 1/2"	0.153 (L/480)	0.364 (36%)	L	L
TL Defl inch	0.105 (L/700)	3'3 1/2"	0.204 (L/360)	0.514 (51%)	D+L	L

Design Notes

- 1 Provide support to prevent lateral movement and rotation at the end bearings. Lateral support may also be required at the interior bearings by the building code.
- 2 Fasten all plies using 2 rows of 10d Box nails (.128x3") at 12" o.c. Maximum end distance not to exceed 6".
- 3 Refer to last page of calculations for fasteners required for specified loads.
- 4 Girders are designed to be supported on the bottom edge only.
- 5 Top loads must be supported equally by all plies.
- 6 Top must be laterally braced at end bearings.
- 7 Bottom must be laterally braced at end bearings.
- 8 Lateral slenderness ratio based on single ply width.

ID	Load Type	Location	Trib Width	Side	Dead 0.9	Live 1	Snow 1.15	Wind 1.6	Const. 1.25	Comments
1	Uniform			Top	102 PLF	304 PLF	0 PLF	0 PLF	0 PLF	F2
2	Uniform			Top	349 PLF	349 PLF	0 PLF	0 PLF	0 PLF	A1
3	Uniform			Top	120 PLF	0 PLF	0 PLF	0 PLF	0 PLF	Wall Above
	Self Weight				7 PLF					

Notes

Calculated Structured Designs is responsible only of the structural adequacy of this component based on the design criteria and loadings shown. It is the responsibility of the customer and/or the contractor to ensure the component suitability of the intended application, and to verify the dimensions and loads.

Lumber

1. Dry service conditions, unless noted otherwise
2. LVL not to be treated with fire retardant or corrosive

chemicals

Handling & Installation

1. LVL beams must not be cut or drilled
2. Refer to manufacturer's product information regarding installation requirements, multi-ply fastening details, beam strength values, and code approvals
3. Damaged Beams must not be used
4. Design assumes top edge is laterally restrained
5. Provide lateral support at bearing points to avoid lateral displacement and rotation

6. For flat roofs provide proper drainage to prevent ponding

This design is valid until 11/3/2024

Manufacturer Info

Metsä Wood
 301 Merritt 7 Building, 2nd Floor
 Norwalk, CT 06851
 (800) 622-5850
www.metsawood.com/us

Comtech, Inc.
 1001 S. Reilly Road, Suite #639
 Fayetteville, NC
 USA
 28314
 910-864-TRUS



BM4 Kerto-S LVL 1.750" X 9.250" 2-Ply - PASSED

Level: Level

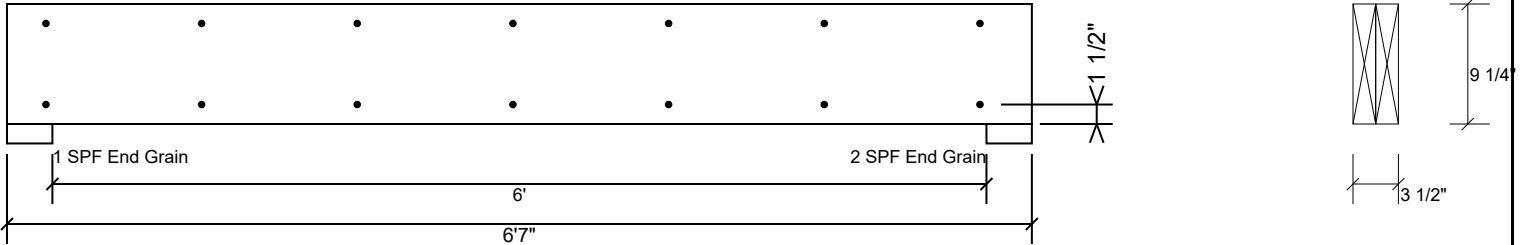

Multi-Ply Analysis

Fasten all plies using 2 rows of 10d Box nails (.128x3") at 12" o.c.. Maximum end distance not to exceed 6".

Capacity	0.0 %
Load	0.0 PLF
Yield Limit per Foot	163.7 PLF
Yield Limit per Fastener	81.9 lb.
Yield Mode	IV
Edge Distance	1 1/2"
Min. End Distance	3"
Load Combination	
Duration Factor	1.00

Notes

Calculated Structured Designs is responsible only of the structural adequacy of this component based on the design criteria and loadings shown. It is the responsibility of the customer and/or the contractor to ensure the component suitability of the intended application, and to verify the dimensions and loads.

Lumber

1. Dry service conditions, unless noted otherwise
2. LVL not to be treated with fire retardant or corrosive

chemicals

Handling & Installation

1. LVL beams must not be cut or drilled
2. Refer to manufacturer's product information regarding installation requirements, multi-ply fastening details, beam strength values, and code approvals
3. Damaged Beams must not be used
4. Design assumes top edge is laterally restrained
5. Provide lateral support at bearing points to avoid lateral displacement and rotation

6. For flat roofs provide proper drainage to prevent ponding

This design is valid until 11/3/2024

Manufacturer Info

Metsä Wood
 301 Merritt 7 Building, 2nd Floor
 Norwalk, CT 06851
 (800) 622-5850
www.metsawood.com/us

Comtech, Inc.
 1001 S. Reilly Road, Suite #639
 Fayetteville, NC
 USA
 28314
 910-864-TRUS



BM5 Kerto-S LVL 1.750" X 11.875" 2-Ply - PASSED

Level: Level

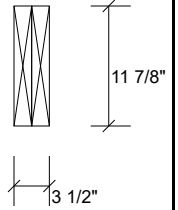
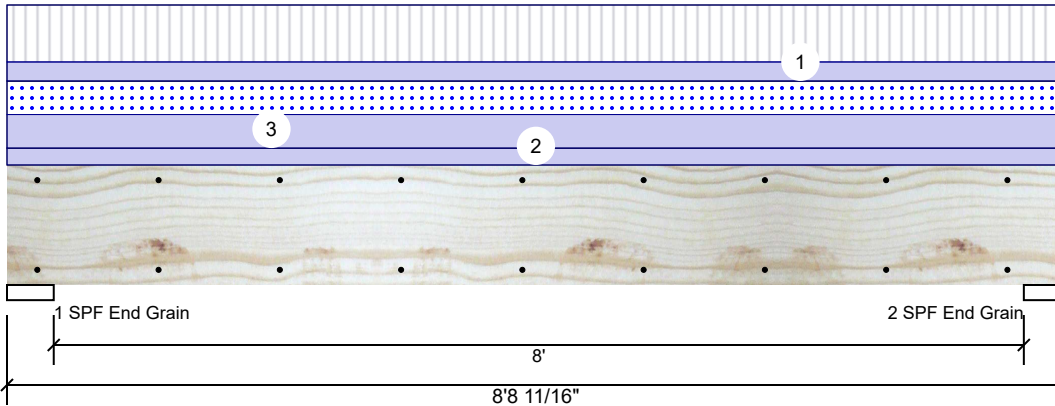

Member Information

Type:	Girder	Application:	Floor
Plies:	2	Design Method:	ASD
Moisture Condition:	Dry	Building Code:	IBC 2012
Deflection LL:	480	Load Sharing:	No
Deflection TL:	240	Deck:	Not Checked
Importance:	Normal - II		
Temperature:	Temp <= 100°F		

Reactions UNPATTERNED lb (Uplift)

Brg	Direction	Live	Dead	Snow	Wind	Const
1	Vertical	1772	2203	1044	0	0
2	Vertical	1753	2179	1033	0	0

Bearings

Bearing	Length	Dir.	Cap.	React D/L lb	Total	Ld. Case	Ld. Comb.
1 - SPF End Grain	4.625"	Vert	32%	2203 / 2112	4314	L	D+0.75(L+S)
2 - SPF End Grain	4.063"	Vert	36%	2179 / 2089	4268	L	D+0.75(L+S)

Analysis Results

Analysis	Actual	Location	Allowed	Capacity	Comb.	Case
Moment	7478 ft-lb	4' 5/8"	19911 ft-lb	0.376 (38%)	D+L	L
Unbraced	8118 ft-lb	4' 5/8"	11006 ft-lb	0.738 (74%)	D+0.75(L+S)	L
Shear	2737 lb	1' 1/2"	8867 lb	0.309 (31%)	D+L	L
LL Defl inch	0.059 (L/1643)	4' 11/16"	0.203 (L/480)	0.292 (29%)	0.75(L+S)	L
TL Defl inch	0.121 (L/804)	4' 11/16"	0.406 (L/240)	0.298 (30%)	D+0.75(L+S)	L

Design Notes

- Provide support to prevent lateral movement and rotation at the end bearings. Lateral support may also be required at the interior bearings by the building code.
- Fasten all plies using 2 rows of 10d Box nails (.128x3") at 12" o.c. Maximum end distance not to exceed 6".
- Refer to last page of calculations for fasteners required for specified loads.
- Girders are designed to be supported on the bottom edge only.
- Top loads must be supported equally by all plies.
- Top must be laterally braced at end bearings.
- Bottom must be laterally braced at end bearings.
- Lateral slenderness ratio based on single ply width.

ID	Load Type	Location	Trib Width	Side	Dead 0.9	Live 1	Snow 1.15	Wind 1.6	Const. 1.25	Comments
1	Part. Uniform	0-0-0 to 8-8-11		Top	135 PLF	404 PLF	0 PLF	0 PLF	0 PLF	F3
2	Uniform			Top	120 PLF	0 PLF	0 PLF	0 PLF	0 PLF	Wall Above
3	Uniform			Top	238 PLF	0 PLF	238 PLF	0 PLF	0 PLF	C1
	Self Weight				9 PLF					

Notes

Calculated Structural Designs is responsible only of the structural adequacy of this component based on the design criteria and loadings shown. It is the responsibility of the customer and/or the contractor to ensure the component suitability of the intended application, and to verify the dimensions and loads.

Lumber

- Dry service conditions, unless noted otherwise
- LVL not to be treated with fire retardant or corrosive chemicals

chemicals

Handling & Installation

- LVL beams must not be cut or drilled
- Refer to manufacturer's product information regarding installation requirements, multi-ply fastening details, beam strength values, and code approvals
- Damaged Beams must not be used
- Design assumes top edge is laterally restrained
- Provide lateral support at bearing points to avoid lateral displacement and rotation

6. For flat roofs provide proper drainage to prevent ponding

This design is valid until 11/3/2024

Manufacturer Info

Metsä Wood
 301 Merritt 7 Building, 2nd Floor
 Norwalk, CT 06851
 (800) 622-5850
www.metsawood.com/us

Comtech, Inc.
 1001 S. Reilly Road, Suite #639
 Fayetteville, NC
 USA
 28314
 910-864-TRUS



BM5 Kerto-S LVL 1.750" X 11.875" 2-Ply - PASSED

Level: Level

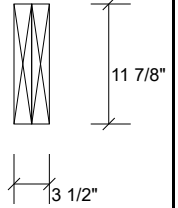
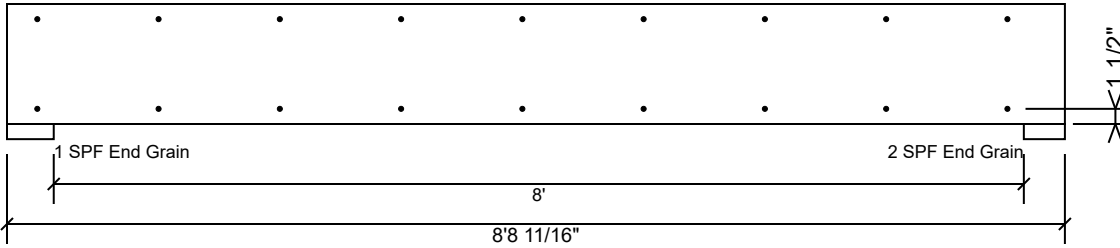

Multi-Ply Analysis

Fasten all plies using 2 rows of 10d Box nails (.128x3") at 12" o.c.. Maximum end distance not to exceed 6".

Capacity	0.0 %
Load	0.0 PLF
Yield Limit per Foot	163.7 PLF
Yield Limit per Fastener	81.9 lb.
Yield Mode	IV
Edge Distance	1 1/2"
Min. End Distance	3"
Load Combination	
Duration Factor	1.00

Notes

Calculated Structured Designs is responsible only of the structural adequacy of this component based on the design criteria and loadings shown. It is the responsibility of the customer and/or the contractor to ensure the component suitability of the intended application, and to verify the dimensions and loads.

Lumber

1. Dry service conditions, unless noted otherwise
2. LVL not to be treated with fire retardant or corrosive

chemicals

Handling & Installation

1. LVL beams must not be cut or drilled
2. Refer to manufacturer's product information regarding installation requirements, multi-ply fastening details, beam strength values, and code approvals
3. Damaged Beams must not be used
4. Design assumes top edge is laterally restrained
5. Provide lateral support at bearing points to avoid lateral displacement and rotation

6. For flat roofs provide proper drainage to prevent ponding

This design is valid until 11/3/2024

Manufacturer Info

Metsä Wood
 301 Merritt 7 Building, 2nd Floor
 Norwalk, CT 06851
 (800) 622-5850
www.metsawood.com/us

Comtech, Inc.
 1001 S. Reilly Road, Suite #639
 Fayetteville, NC
 USA
 28314
 910-864-TRUS



GDH Kerto-S LVL 1.750" X 11.875" 2-Ply - PASSED

Level: Level

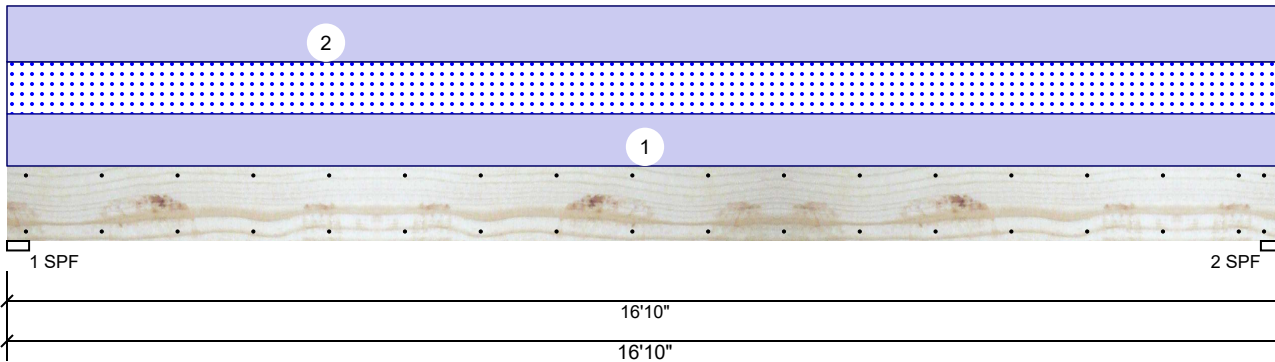

Member Information

Type:	Girder	Application:	Floor
Plies:	2	Design Method:	ASD
Moisture Condition:	Dry	Building Code:	IBC 2012
Deflection LL:	480	Load Sharing:	No
Deflection TL:	240	Deck:	Not Checked
Importance:	Normal - II		
Temperature:	Temp <= 100°F		

Reactions UNPATTERNED lb (Uplift)

Brg	Direction	Live	Dead	Snow	Wind	Const
1	Vertical	0	1054	471	0	0
2	Vertical	0	1054	471	0	0

Bearings

Bearing	Length	Dir.	Cap.	React D/L lb	Total	Ld. Case	Ld. Comb.
1 - SPF	3.500"	Vert	29%	1054 / 471	1525	L	D+S
2 - SPF	3.500"	Vert	29%	1054 / 471	1525	L	D+S

Analysis Results

Analysis	Actual	Location	Allowed	Capacity	Comb.	Case
Moment	6075 ft-lb	8'5"	22897 ft-lb	0.265 (27%)	D+S	L
Unbraced	6075 ft-lb	8'5"	6086 ft-lb	0.998 (100%)	D+S	L
Shear	1413 lb	1'3 3/8"	10197 lb	0.139 (14%)	D+S	L
LL Defl inch	0.098 (L/2006)	8'5 1/16"	0.409 (L/480)	0.239 (24%)	S	L
TL Defl inch	0.317 (L/620)	8'5 1/16"	0.819 (L/240)	0.387 (39%)	D+S	L

Design Notes

- Provide support to prevent lateral movement and rotation at the end bearings. Lateral support may also be required at the interior bearings by the building code.
- Fasten all plies using 2 rows of 10d Box nails (.128x3") at 12" o.c. Maximum end distance not to exceed 6".
- Refer to last page of calculations for fasteners required for specified loads.
- Girders are designed to be supported on the bottom edge only.
- Top loads must be supported equally by all plies.
- Top must be laterally braced at end bearings.
- Bottom must be laterally braced at end bearings.
- Lateral slenderness ratio based on single ply width.

ID	Load Type	Location	Trib Width	Side	Dead 0.9	Live 1	Snow 1.15	Wind 1.6	Const. 1.25	Comments
1	Uniform			Near Face	56 PLF	0 PLF	56 PLF	0 PLF	0 PLF	J3
2	Uniform			Top	60 PLF	0 PLF	0 PLF	0 PLF	0 PLF	Wall Above
	Self Weight				9 PLF					

Notes

Calculated Structured Designs is responsible only of the structural adequacy of this component based on the design criteria and loadings shown. It is the responsibility of the customer and/or the contractor to ensure the component suitability of the intended application, and to verify the dimensions and loads.

Lumber

- Dry service conditions, unless noted otherwise
- LVL not to be treated with fire retardant or corrosive chemicals

chemicals

Handling & Installation

- LVL beams must not be cut or drilled
- Refer to manufacturer's product information regarding installation requirements, multi-ply fastening details, beam strength values, and code approvals
- Damaged Beams must not be used
- Design assumes top edge is laterally restrained
- Provide lateral support at bearing points to avoid lateral displacement and rotation

6. For flat roofs provide proper drainage to prevent ponding

This design is valid until 11/3/2024

Manufacturer Info

Metsä Wood
 301 Merritt 7 Building, 2nd Floor
 Norwalk, CT 06851
 (800) 622-5850
www.metsawood.com/us

Comtech, Inc.
 1001 S. Reilly Road, Suite #639
 Fayetteville, NC
 USA
 28314
 910-864-TRUS



GDH Kerto-S LVL 1.750" X 11.875" 2-Ply - PASSED

Level: Level

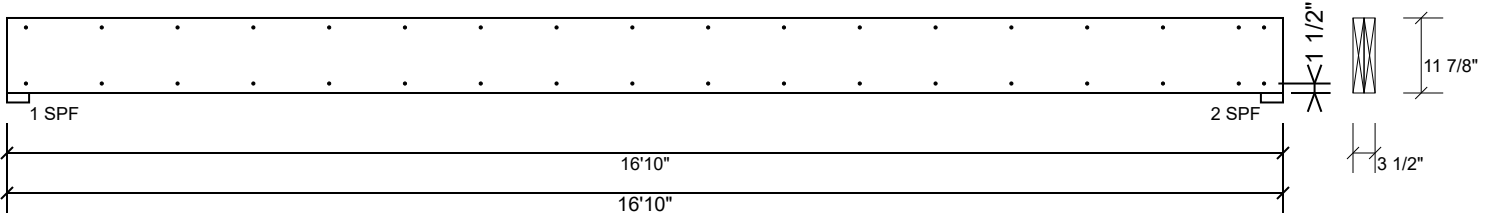

Multi-Ply Analysis

Fasten all plies using 2 rows of 10d Box nails (.128x3") at 12" o.c.. Maximum end distance not to exceed 6".

Capacity	29.7 %
Load	56.0 PLF
Yield Limit per Foot	188.3 PLF
Yield Limit per Fastener	94.1 lb.
Yield Mode	IV
Edge Distance	1 1/2"
Min. End Distance	3"
Load Combination	D+S
Duration Factor	1.15

Notes

Calculated Structured Designs is responsible only of the structural adequacy of this component based on the design criteria and loadings shown. It is the responsibility of the customer and/or the contractor to ensure the component suitability of the intended application, and to verify the dimensions and loads.

Lumber

1. Dry service conditions, unless noted otherwise
2. LVL not to be treated with fire retardant or corrosive

chemicals

Handling & Installation

1. LVL beams must not be cut or drilled
2. Refer to manufacturer's product information regarding installation requirements, multi-ply fastening details, beam strength values, and code approvals
3. Damaged Beams must not be used
4. Design assumes top edge is laterally restrained
5. Provide lateral support at bearing points to avoid lateral displacement and rotation

6. For flat roofs provide proper drainage to prevent ponding

This design is valid until 11/3/2024

Manufacturer Info

Metsä Wood
 301 Merritt 7 Building, 2nd Floor
 Norwalk, CT 06851
 (800) 622-5850
www.metsawood.com/us

Comtech, Inc.
 1001 S. Reilly Road, Suite #639
 Fayetteville, NC
 USA
 28314
 910-864-TRUS



GDH2 S-P-F #2 2.000" X 12.000" 2-Ply - PASSED

Level: Level

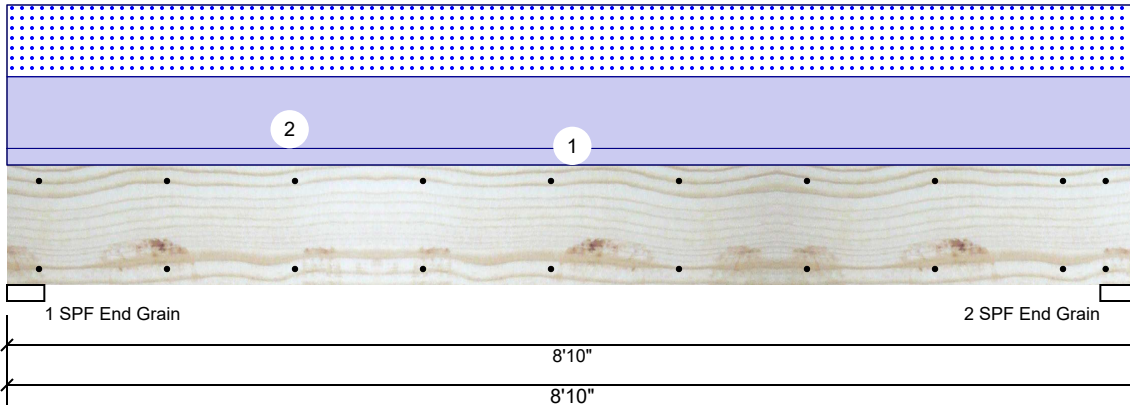

Member Information

Type:	Girder
Plies:	2
Moisture Condition:	Dry
Deflection LL:	480
Deflection TL:	360
Importance:	Normal - II
Temperature:	Temp <= 100°F

Application:	Floor
Design Method:	ASD
Building Code:	IBC 2012
Load Sharing:	No
Deck:	Not Checked

Reactions UNPATTERNED lb (Uplift)

Brg	Direction	Live	Dead	Snow	Wind	Const
1	Vertical	0	1413	1148	0	0
2	Vertical	0	1413	1148	0	0

Bearings

Bearing	Length	Dir.	Cap.	React D/L lb	Total	Ld. Case	Ld. Comb.
1 - SPF End Grain	3.500"	Vert	57%	1413 / 1148	2562	L	D+S
2 - SPF End Grain	3.500"	Vert	57%	1413 / 1148	2562	L	D+S

Analysis Results

Analysis	Actual	Location	Allowed	Capacity	Comb.	Case
Moment	5085 ft-lb	4'5"	5306 ft-lb	0.958 (96%)	D+S	L
Unbraced	5085 ft-lb	4'5"	5088 ft-lb	0.999 (100%)	D+S	L
Shear	1849 lb	7'7 1/4"	3493 lb	0.529 (53%)	D+S	L
LL Defl inch	0.058 (L/1740)	4'5 1/16"	0.209 (L/480)	0.276 (28%)	S	L
TL Defl inch	0.129 (L/780)	4'5 1/16"	0.279 (L/360)	0.461 (46%)	D+S	L

Design Notes

- 1 Provide support to prevent lateral movement and rotation at the end bearings. Lateral support may also be required at the interior bearings by the building code.
- 2 Fasten all plies using 2 rows of 10d Box nails (.128x3") at 12" o.c. Maximum end distance not to exceed 6".
- 3 Refer to last page of calculations for fasteners required for specified loads.
- 4 Girders are designed to be supported on the bottom edge only.
- 5 Top loads must be supported equally by all plies.
- 6 Top must be laterally braced at a maximum of 3'3 5/8" o.c.
- 7 Bottom must be laterally braced at end bearings.
- 8 Lateral slenderness ratio based on single ply width.

ID	Load Type	Location	Trib Width	Side	Dead 0.9	Live 1	Snow 1.15	Wind 1.6	Const. 1.25	Comments
1	Uniform			Top	60 PLF	0 PLF	0 PLF	0 PLF	0 PLF	Wall Above
2	Uniform			Top	260 PLF	0 PLF	260 PLF	0 PLF	0 PLF	G1

Manufacturer Info

Comtech, Inc.
 1001 S. Reilly Road, Suite #639
 Fayetteville, NC
 USA
 28314
 910-864-TRUS



This design is valid until 11/3/2024

GDH2 S-P-F #2 2.000" X 12.000" 2-Ply - PASSED

Level: Level

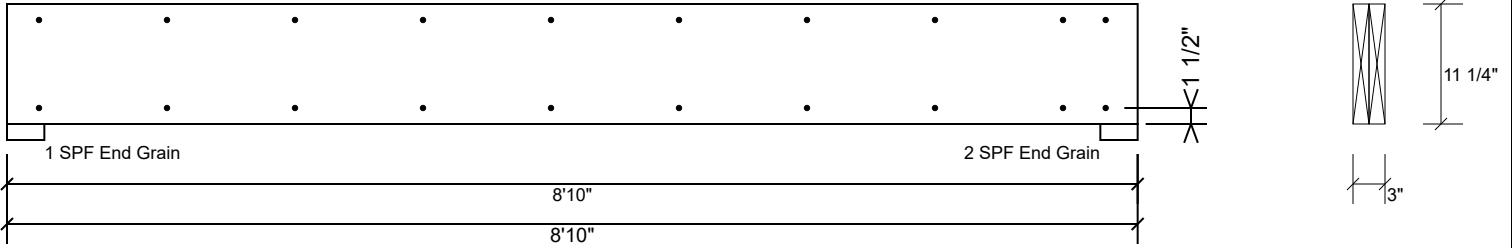

Multi-Ply Analysis

Fasten all plies using 2 rows of 10d Box nails (.128x3") at 12" o.c.. Maximum end distance not to exceed 6".

Capacity	0.0 %
Load	0.0 PLF
Yield Limit per Foot	157.4 PLF
Yield Limit per Fastener	78.7 lb.
Yield Mode	IV
Edge Distance	1 1/2"
Min. End Distance	3"
Load Combination	
Duration Factor	1.00

Manufacturer Info

Comtech, Inc.
 1001 S. Reilly Road, Suite #639
 Fayetteville, NC
 USA
 28314
 910-864-TRUS



This design is valid until 11/3/2024

RE: J0323-1215
Lot 43 Liberty Meadow

Trenco
818 Soundside Rd
Edenton, NC 27932

Site Information:

Customer: Project Name: J0323-1215
Lot/Block: Model:
Address: Subdivision:
City: State:

General Truss Engineering Criteria & Design Loads (Individual Truss Design Drawings Show Special Loading Conditions):

Design Code: IRC2015/TPI2014 Design Program: MiTek 20/20 8.4
Wind Code: N/A Wind Speed: N/A mph
Roof Load: N/A psf Floor Load: 55.0 psf

This package includes 10 individual, dated Truss Design Drawings and 0 Additional Drawings.

No.	Seal#	Truss Name	Date
1	I56917899	ET1	3/1/2023
2	I56917900	ET2	3/1/2023
3	I56917901	ET3	3/1/2023
4	I56917902	F1	3/1/2023
5	I56917903	F2	3/1/2023
6	I56917904	F3	3/1/2023
7	I56917905	F4	3/1/2023
8	I56917906	F4A	3/1/2023
9	I56917907	F5	3/1/2023
10	I56917908	FG1	3/1/2023

The truss drawing(s) referenced above have been prepared by Truss Engineering Co. under my direct supervision based on the parameters provided by Comtech, Inc - Fayetteville.

Truss Design Engineer's Name: Gilbert, Eric

My license renewal date for the state of North Carolina is December 31, 2023.

North Carolina COA: C-0844

IMPORTANT NOTE: The seal on these truss component designs is a certification that the engineer named is licensed in the jurisdiction(s) identified and that the designs comply with ANSI/TPI 1. These designs are based upon parameters shown (e.g., loads, supports, dimensions, shapes and design codes), which were given to TRENCO. Any project specific information included is for TRENCO customers file reference purpose only, and was not taken into account in the preparation of these designs. TRENCO has not independently verified the applicability of the design parameters or the designs for any particular building. Before use, the building designer should verify applicability of design parameters and properly incorporate these designs into the overall building design per ANSI/TPI 1, Chapter 2.



Job J0323-1215	Truss ET1	Truss Type GABLE	Qty 1	Ply 1	Lot 43 Liberty Meadow I56917899
-------------------	--------------	---------------------	----------	----------	------------------------------------

Comtech, Inc. Fayetteville, NC - 28314,

8.430 s Jan 6 2022 MiTek Industries, Inc. Wed Mar 1 09:54:46 2023 Page 1
ID:aTXuLo?nW09qtpROz2WQ0wydkZW-vFAMz0lokDfoj_POPHmBiuM3HfXVKefis35yipzfKAt

0-1/8

0-1/8

Scale = 1:55.0

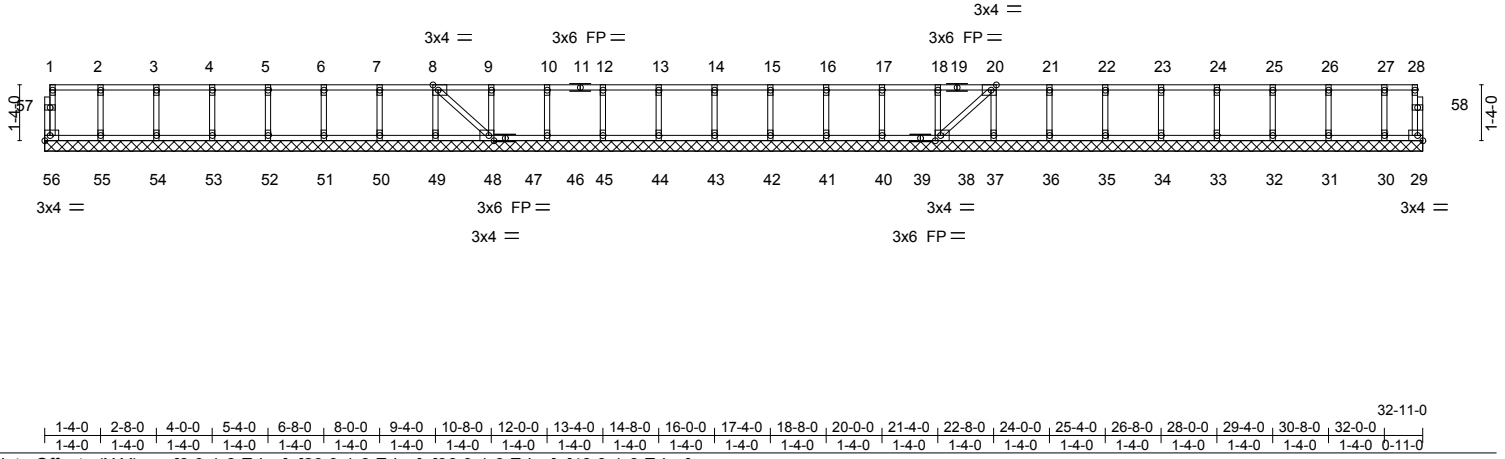

LOADING (psf)	SPACING-	2-0-0	CSI.	DEFL.	in (loc)	l/defl	L/d	PLATES	GRIP
TCLL 40.0	Plate Grip DOL	1.00	TC 0.06	Vert(LL)	n/a	-	n/a	MT20	244/190
TCDL 10.0	Lumber DOL	1.00	BC 0.01	Vert(CT)	n/a	-	n/a		
BCLL 0.0	Rep Stress Incr	YES	WB 0.03	Horz(CT)	-0.00	38	n/a		
BCDL 5.0	Code IRC2015/TPI2014		Matrix-S						
								Weight: 147 lb	FT = 20%F, 11%E

LUMBER-	BRACING-
TOP CHORD 2x4 SP No.1(flat)	TOP CHORD Structural wood sheathing directly applied or 6-0-0 oc purlins, except end verticals.
BOT CHORD 2x4 SP No.1(flat)	BOT CHORD Rigid ceiling directly applied or 6-0-0 oc bracing.
WEBS 2x4 SP No.3(flat)	
OTHERS 2x4 SP No.3(flat)	

REACTIONS. All bearings 32-11-0.
(lb) - Max Grav All reactions 250 lb or less at joint(s) 56, 29, 55, 54, 53, 52, 51, 50, 49, 48, 46, 45, 44, 43, 42, 41, 40, 38, 37, 36, 35, 34, 33, 32, 31, 30

FORCES. (lb) - Max. Comp./Max. Ten. - All forces 250 (lb) or less except when shown.

- NOTES-**
- 1) All plates are 1.5x3 MT20 unless otherwise indicated.
 - 2) Plates checked for a plus or minus 1 degree rotation about its center.
 - 3) Gable requires continuous bottom chord bearing.
 - 4) Truss to be fully sheathed from one face or securely braced against lateral movement (i.e. diagonal web).
 - 5) Gable studs spaced at 1-4-0 oc.
 - 6) Recommend 2x6 strongbacks, on edge, spaced at 10-0-0 oc and fastened to each truss with 3-10d (0.131" X 3") nails. Strongbacks to be attached to walls at their outer ends or restrained by other means.

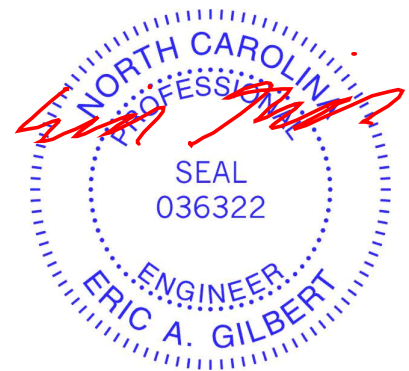

March 1, 2023

Job J0323-1215	Truss ET2	Truss Type GABLE	Qty 1	Ply 1	Lot 43 Liberty Meadow I56917900
-------------------	--------------	---------------------	----------	----------	------------------------------------

Comtech, Inc. Fayetteville, NC - 28314,

8.430 s Jan 6 2022 MiTek Industries, Inc. Wed Mar 1 09:54:47 2023 Page 1
ID:aTXuLo?nW09qtpROz2WQ0wydkZW-NRkiAMJQVXnfl8_az_HQE6vDv3tj35vr5jrWEFzfKAs

0-1-8

Scale = 1:30.5

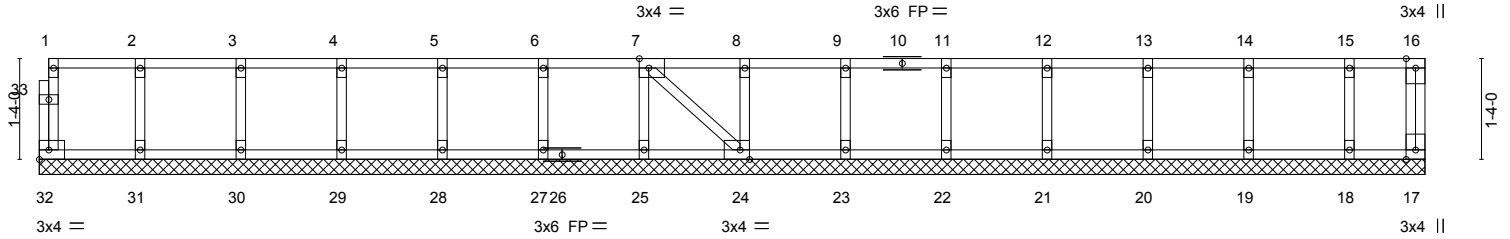

1-4-0	2-8-0	4-0-0	5-4-0	6-8-0	8-0-0	9-4-0	10-8-0	12-0-0	13-4-0	14-8-0	16-0-0	17-4-0	18-4-0
1-4-0	1-4-0	1-4-0	1-4-0	1-4-0	1-4-0	1-4-0	1-4-0	1-4-0	1-4-0	1-4-0	1-4-0	1-4-0	1-0-0

LOADING (psf)		SPACING-		CSI.		DEFL.		PLATES		GRIP	
TCLL	40.0	Plate Grip DOL	1.00	TC	0.07	Vert(LL)	n/a	in (loc)	l/defl	L/d	MT20
TCDL	10.0	Lumber DOL	1.00	BC	0.01	Vert(CT)	n/a	-	n/a	999	244/190
BCLL	0.0	Rep Stress Incr	NO	WB	0.03	Horz(CT)	0.00	17	n/a	n/a	
BCDL	5.0	Code IRC2015/TPI2014		Matrix-S							Weight: 84 lb FT = 20%F, 11%E

LUMBER-	BRACING-
TOP CHORD 2x4 SP No.1(flat)	TOP CHORD Structural wood sheathing directly applied or 6-0-0 oc purlins, except end verticals.
BOT CHORD 2x4 SP No.1(flat)	BOT CHORD Rigid ceiling directly applied or 10-0-0 oc bracing.
WEBS 2x4 SP No.3(flat)	
OTHERS 2x4 SP No.3(flat)	

REACTIONS. All bearings 18-4-0.
(lb) - Max Grav All reactions 250 lb or less at joint(s) 32, 17, 31, 30, 29, 28, 27, 25, 24, 23, 22, 21, 20, 19, 18

FORCES. (lb) - Max. Comp./Max. Ten. - All forces 250 (lb) or less except when shown.

- NOTES-**
- All plates are 1.5x3 MT20 unless otherwise indicated.
 - Plates checked for a plus or minus 1 degree rotation about its center.
 - Gable requires continuous bottom chord bearing.
 - Truss to be fully sheathed from one face or securely braced against lateral movement (i.e. diagonal web).
 - Gable studs spaced at 1-4-0 oc.
 - Recommend 2x6 strongbacks, on edge, spaced at 10-0-0 oc and fastened to each truss with 3-10d (0.131" X 3") nails. Strongbacks to be attached to walls at their outer ends or restrained by other means.
 - CAUTION, Do not erect truss backwards.



March 1, 2023

<p>WARNING - Verify design parameters and READ NOTES ON THIS AND INCLUDED MITEK REFERENCE PAGE MII-7473 rev. 5/19/2020 BEFORE USE.</p> <p>Design valid for use only with MiTek® connectors. This design is based only upon parameters shown, and is for an individual building component, not a truss system. Before use, the building designer must verify the applicability of design parameters and properly incorporate this design into the overall building design. Bracing indicated is to prevent buckling of individual truss web and/or chord members only. Additional temporary and permanent bracing is always required for stability and to prevent collapse with possible personal injury and property damage. For general guidance regarding the fabrication, storage, delivery, erection and bracing of trusses and truss systems, see ANSI/TPI1 Quality Criteria, DSB-89 and BCSI Building Component Safety Information available from Truss Plate Institute, 2670 Crain Highway, Suite 203 Waldorf, MD 20601</p>	<p>ENGINEERING BY</p> <p>TRENCO</p> <p>A MiTek Affiliate</p> <p>818 Soundside Road Edenton, NC 27932</p>
--	---

Job J0323-1215	Truss ET3	Truss Type GABLE	Qty 1	Ply 1	Lot 43 Liberty Meadow I56917901
-------------------	--------------	---------------------	----------	----------	------------------------------------

Comtech, Inc. Fayetteville, NC - 28314,

8.430 s Jan 6 2022 MiTek Industries, Inc. Wed Mar 1 09:54:48 2023 Page 1
ID:aTXuLo?nW09qtpROz2WQ0wydkZW-rdl7OiK2GrvWylZnWipfnJSPnTDzoY9_KNa3nhzfKAR

0-1-8

Scale: 3/8"=1'

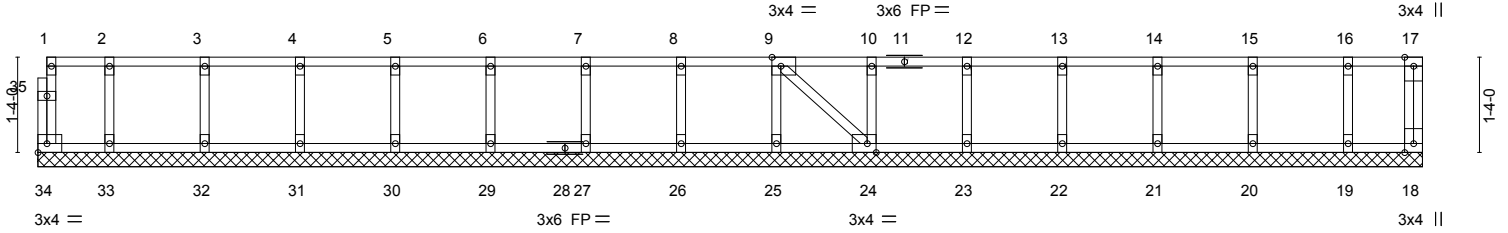

1-0-0	2-4-0	3-8-0	5-0-0	6-4-0	7-8-0	9-0-0	10-4-0	11-8-0	13-0-0	14-4-0	15-8-0	17-0-0	18-4-0	19-4-8
1-0-0	1-4-0	1-4-0	1-4-0	1-4-0	1-4-0	1-4-0	1-4-0	1-4-0	1-4-0	1-4-0	1-4-0	1-4-0	1-4-0	1-0-8

LOADING (psf)		SPACING-		CSI.		DEFL.		PLATES		GRIP	
TCLL	40.0	Plate Grip DOL	1.00	TC	0.06	in (loc)	l/defl	MT20	244/190	Weight: 89 lb FT = 20%F, 11%E	
TCDL	10.0	Lumber DOL	1.00	BC	0.01	Vert(LL)	n/a - n/a				
BCLL	0.0	Rep Stress Incr	YES	WB	0.03	Vert(CT)	n/a - n/a				
BCDL	5.0	Code IRC2015/TPI2014		Matrix-S		Horz(CT)	0.00 18 n/a n/a				

LUMBER-		BRACING-	
TOP CHORD	2x4 SP No.1(flat)	TOP CHORD	Structural wood sheathing directly applied or 6-0-0 oc purlins, except end verticals.
BOT CHORD	2x4 SP No.1(flat)	BOT CHORD	Rigid ceiling directly applied or 10-0-0 oc bracing.
WEBS	2x4 SP No.3(flat)		
OTHERS	2x4 SP No.3(flat)		

REACTIONS. All bearings 19-4-8.
(lb) - Max Grav All reactions 250 lb or less at joint(s) 34, 18, 33, 32, 31, 30, 29, 27, 26, 25, 24, 23, 22, 21, 20, 19

FORCES. (lb) - Max. Comp./Max. Ten. - All forces 250 (lb) or less except when shown.

- NOTES-**
- 1) All plates are 1.5x3 MT20 unless otherwise indicated.
 - 2) Plates checked for a plus or minus 1 degree rotation about its center.
 - 3) Gable requires continuous bottom chord bearing.
 - 4) Truss to be fully sheathed from one face or securely braced against lateral movement (i.e. diagonal web).
 - 5) Gable studs spaced at 1-4-0 oc.
 - 6) Recommend 2x6 strongbacks, on edge, spaced at 10-0-0 oc and fastened to each truss with 3-10d (0.131" X 3") nails. Strongbacks to be attached to walls at their outer ends or restrained by other means.
 - 7) CAUTION, Do not erect truss backwards.

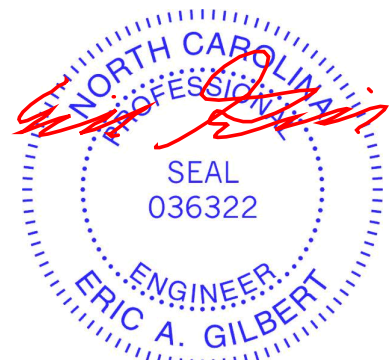

March 1, 2023

<p>WARNING - Verify design parameters and READ NOTES ON THIS AND INCLUDED MITEK REFERENCE PAGE MII-7473 rev. 5/19/2020 BEFORE USE.</p> <p>Design valid for use only with MiTek® connectors. This design is based only upon parameters shown, and is for an individual building component, not a truss system. Before use, the building designer must verify the applicability of design parameters and properly incorporate this design into the overall building design. Bracing indicated is to prevent buckling of individual truss web and/or chord members only. Additional temporary and permanent bracing is always required for stability and to prevent collapse with possible personal injury and property damage. For general guidance regarding the fabrication, storage, delivery, erection and bracing of trusses and truss systems, see ANSI/TPI1 Quality Criteria, DSB-89 and BCSI Building Component Safety Information available from Truss Plate Institute, 2670 Crain Highway, Suite 203 Waldorf, MD 20601</p>	<p>ENGINEERING BY</p>  <p>A MiTek Affiliate</p> <p>818 Soundside Road Edenton, NC 27932</p>
--	--

Job J0323-1215	Truss F1	Truss Type Floor	Qty 7	Ply 1	Lot 43 Liberty Meadow I56917902
-------------------	-------------	---------------------	----------	----------	------------------------------------

Comtech, Inc. Fayetteville, NC - 28314,

8.430 s Jan 6 2022 MiTek Industries, Inc. Wed Mar 1 09:54:50 2023 Page 1
ID:aTXuLo?nW09qtpROz2WQ0wydkZW-o0QtpOLJoS9ECcj9e7r7skXcJGIlGJMHng3ArazfKAP

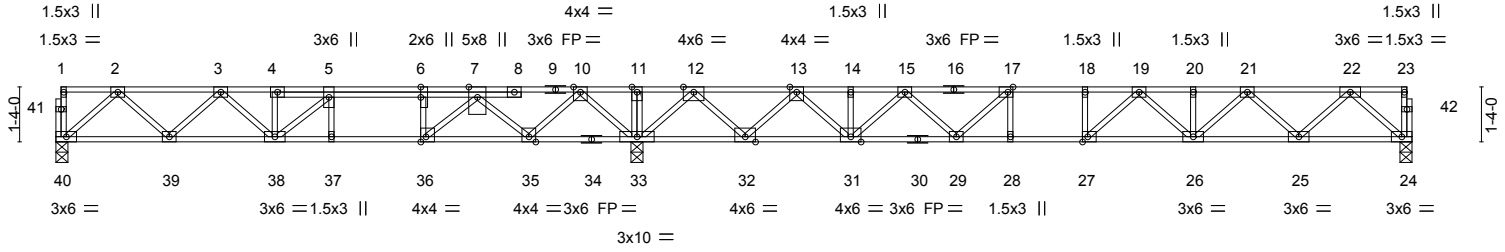

Plate Offsets (X,Y)--	[6:0-3-0,0-0-0], [17:0-1-8,Edge], [27:0-1-8,Edge], [36:0-1-8,Edge]
-----------------------	--

LOADING (psf)	SPACING-	CSI.	DEFL.	PLATES	GRIP
TCLL 40.0	2-0-0	TC 0.63	in (loc) l/defl L/d	MT20	244/190
TCDL 10.0	Plate Grip DOL 1.00	BC 0.82	Vert(LL) -0.20 27 >999 480		
BCLL 0.0	Lumber DOL 1.00	WB 0.63	Vert(CT) -0.27 26-27 >820 360		
BCDL 5.0	Rep Stress Incr YES	Matrix-S	Horz(CT) 0.04 24 n/a n/a		
	Code IRC2015/TPI2014			Weight: 180 lb	FT = 20%F, 11%E

LUMBER-	BRACING-
TOP CHORD 2x4 SP No.1(flat)	TOP CHORD Structural wood sheathing directly applied or 6-0-0 oc purlins, except end verticals.
BOT CHORD 2x4 SP No.1(flat)	BOT CHORD Rigid ceiling directly applied or 6-0-0 oc bracing.
WEBS 2x4 SP No.3(flat)	

REACTIONS. (size) 40=0-3-8, 24=0-3-8, 33=0-3-8
Max Grav 40=662(LC 3), 24=882(LC 4), 33=2190(LC 1)

FORCES. (lb) - Max. Comp./Max. Ten. - All forces 250 (lb) or less except when shown.

TOP CHORD 2-3=-1110/36, 3-4=-1659/212, 4-5=-1659/219, 5-6=-1602/621, 6-7=-1602/621, 7-10=-392/1404, 10-11=0/2571, 11-12=0/2571, 12-13=-40/475, 13-14=-1631/0, 14-15=-1631/0, 15-17=-2564/0, 17-18=-2931/0, 18-19=-2931/0, 19-20=-2592/0, 20-21=-2592/0, 21-22=-1586/0

BOT CHORD 39-40=0/704, 38-39=-106/1489, 37-38=-621/1602, 36-37=-621/1602, 35-36=-1086/1024, 33-35=-1709/0, 32-33=-1291/0, 31-32=-200/935, 29-31=0/2220, 28-29=0/2931, 27-28=0/2931, 26-27=0/2856, 25-26=0/2193, 24-25=0/952

WEBS 2-40=935/0, 2-39=-59/564, 3-39=-528/98, 4-38=-325/0, 5-38=0/648, 22-24=-1266/0, 22-25=0/881, 21-25=-845/0, 21-26=0/542, 19-26=-358/0, 19-27=-253/331, 12-33=-1704/0, 12-32=0/1314, 10-33=-1399/0, 10-35=0/993, 7-35=-1033/0, 7-36=0/1214, 6-36=-690/0, 13-32=-1288/0, 13-31=0/991, 15-31=-835/0, 15-29=0/579, 17-29=-718/0

- NOTES-**
- 1) Unbalanced floor live loads have been considered for this design.
 - 2) All plates are 3x4 MT20 unless otherwise indicated.
 - 3) Plates checked for a plus or minus 1 degree rotation about its center.
 - 4) Recommend 2x6 strongbacks, on edge, spaced at 10-0-0 oc and fastened to each truss with 3-10d (0.131" X 3") nails. Strongbacks to be attached to walls at their outer ends or restrained by other means.
 - 5) CAUTION, Do not erect truss backwards.



<p>WARNING - Verify design parameters and READ NOTES ON THIS AND INCLUDED MITEK REFERENCE PAGE MII-7473 rev. 5/19/2020 BEFORE USE.</p> <p>Design valid for use only with MiTek® connectors. This design is based only upon parameters shown, and is for an individual building component, not a truss system. Before use, the building designer must verify the applicability of design parameters and properly incorporate this design into the overall building design. Bracing indicated is to prevent buckling of individual truss web and/or chord members only. Additional temporary and permanent bracing is always required for stability and to prevent collapse with possible personal injury and property damage. For general guidance regarding the fabrication, storage, delivery, erection and bracing of trusses and truss systems, see ANSI/TPI1 Quality Criteria, DSB-89 and BCSI Building Component Safety Information available from Truss Plate Institute, 2670 Crain Highway, Suite 203 Waldorf, MD 20601</p>	<p>ENGINEERING BY TRENCO A MiTek Affiliate</p> <p>818 Soundside Road Edenton, NC 27932</p>
--	--

Job	Truss	Truss Type	Qty	Ply	Lot 43 Liberty Meadow	I56917903
J0323-1215	F2	Floor	3	1		

Comtech, Inc. Fayetteville, NC - 28314,

8.430 s Jan 6 2022 MiTek Industries, Inc. Wed Mar 1 09:54:52 2023 Page 1
 ID:aTXuLo?nW09qtpROz2WQ0wydkZW-kPXeD3NZK3PyRvtYIYtbx9ctN4MkEBaF_YHwSzfKAn

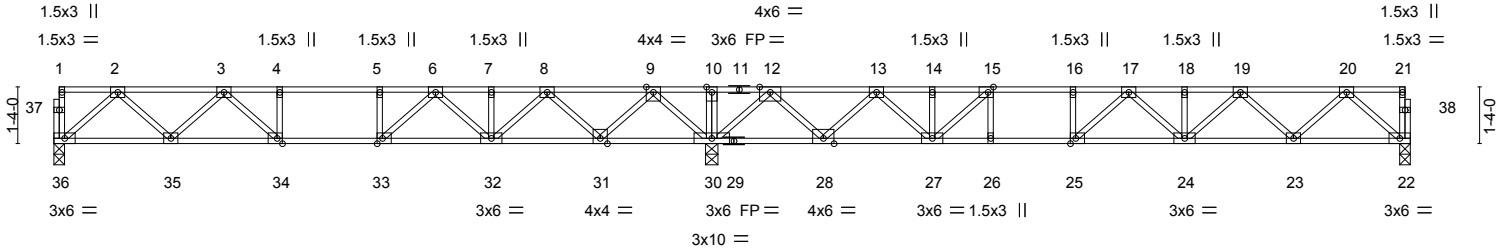

	15-5-12	31-11-0
	15-5-12	16-5-4
Plate Offsets (X,Y)--	[15:0-1-8,Edge], [25:0-1-8,Edge], [33:0-1-8,Edge], [34:0-1-8,Edge]	

LOADING (psf)	SPACING-	CSI.	DEFL.	PLATES	GRIP
TCLL 40.0	2-0-0	TC 0.85	in (loc) l/defl L/d	MT20	244/190
TCDL 10.0	Plate Grip DOL 1.00	BC 0.91	Vert(LL) -0.18 24-25 >999 480		
BCLL 0.0	Lumber DOL 1.00	WB 0.54	Vert(CT) -0.25 24-25 >776 360		
BCDL 5.0	Rep Stress Incr YES	Matrix-S	Horz(CT) 0.04 22 n/a n/a		
	Code IRC2015/TPI2014			Weight: 167 lb	FT = 20%F, 11%E

LUMBER-	BRACING-
TOP CHORD 2x4 SP No.1(flat)	TOP CHORD Structural wood sheathing directly applied or 6-0-0 oc purlins, except end verticals.
BOT CHORD 2x4 SP No.1(flat)	BOT CHORD Rigid ceiling directly applied or 6-0-0 oc bracing.
WEBS 2x4 SP No.3(flat)	

REACTIONS. (size) 36=0-3-0, 30=0-3-8, 22=0-3-0
 Max Grav 36=719(LC 3), 30=2079(LC 1), 22=795(LC 4)

FORCES. (lb) - Max. Comp./Max. Ten. - All forces 250 (lb) or less except when shown.

TOP CHORD 2-3=-1229/0, 3-4=-1941/0, 4-5=-1941/0, 5-6=-1941/0, 6-7=-1408/202, 7-8=-1408/202, 8-9=-241/659, 9-10=0/2218, 10-12=0/2218, 12-13=-523/817, 13-14=-1712/332, 14-15=-1712/332, 15-16=-2291/0, 16-17=-2291/0, 17-18=-2225/0, 18-19=-2225/0, 19-20=-1395/0

BOT CHORD 35-36=0/769, 34-35=0/1668, 33-34=0/1941, 32-33=-35/1748, 31-32=-414/927, 30-31=-1214/0, 28-30=-1129/0, 27-28=-547/1232, 26-27=0/2291, 25-26=0/2291, 24-25=0/2385, 23-24=0/1918, 22-23=0/852

WEBS 2-36=-1022/0, 2-35=0/640, 3-35=-610/0, 3-34=-83/372, 9-30=-1439/0, 9-31=0/1062, 20-22=-1132/0, 20-23=0/755, 19-23=-728/0, 19-24=-1/417, 17-25=-477/33, 12-30=-1508/0, 8-31=-1027/0, 8-32=0/734, 6-32=-547/0, 6-33=0/628, 5-33=-320/0, 12-28=0/1134, 13-28=-1085/0, 13-27=0/740, 15-27=-1088/0, 15-26=0/273

- NOTES-**
- 1) Unbalanced floor live loads have been considered for this design.
 - 2) All plates are 3x4 MT20 unless otherwise indicated.
 - 3) Plates checked for a plus or minus 1 degree rotation about its center.
 - 4) Recommend 2x6 strongbacks, on edge, spaced at 10-0-0 oc and fastened to each truss with 3-10d (0.131" X 3") nails. Strongbacks to be attached to walls at their outer ends or restrained by other means.
 - 5) CAUTION, Do not erect truss backwards.



March 1, 2023

<p>WARNING - Verify design parameters and READ NOTES ON THIS AND INCLUDED MITEK REFERENCE PAGE MII-7473 rev. 5/19/2020 BEFORE USE.</p> <p>Design valid for use only with MiTek® connectors. This design is based only upon parameters shown, and is for an individual building component, not a truss system. Before use, the building designer must verify the applicability of design parameters and properly incorporate this design into the overall building design. Bracing indicated is to prevent buckling of individual truss web and/or chord members only. Additional temporary and permanent bracing is always required for stability and to prevent collapse with possible personal injury and property damage. For general guidance regarding the fabrication, storage, delivery, erection and bracing of trusses and truss systems, see ANSI/TPI1 Quality Criteria, DSB-89 and BCSI Building Component Safety Information available from Truss Plate Institute, 2670 Crain Highway, Suite 203 Waldorf, MD 20601</p>	<p>ENGINEERING BY</p> <p>A MiTek Affiliate</p> <p>818 Soundside Road Edenton, NC 27932</p>
--	--

Job J0323-1215	Truss F3	Truss Type Floor	Qty 9	Ply 1	Lot 43 Liberty Meadow I56917904
-------------------	-------------	---------------------	----------	----------	------------------------------------

Comtech, Inc. Fayetteville, NC - 28314,

8.430 s Jan 6 2022 MiTek Industries, Inc. Wed Mar 1 09:54:53 2023 Page 1

ID:aTXuLo?nW09qtpROz2WQ0wydkZW-Cb50RPNB5NXp33RkJFOqUN97gUjPThFjTelqSvzfKAm

0-1-8

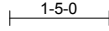
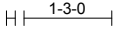

0-1-8
Scale = 1:32.8

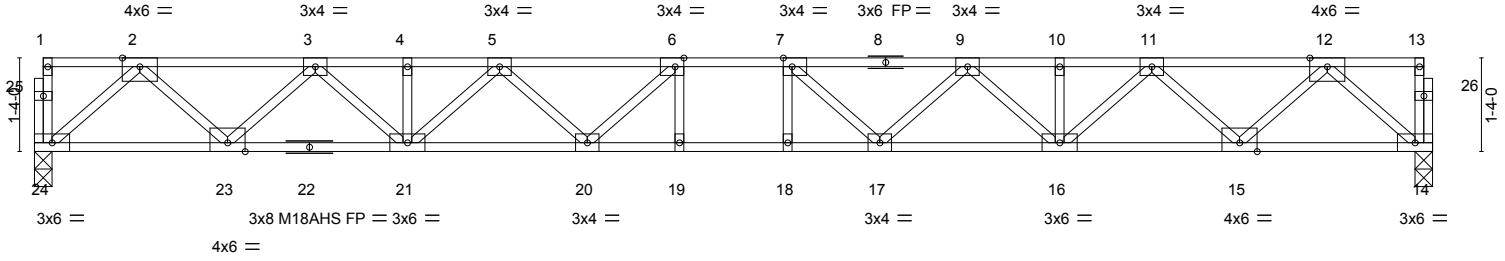

19-11-0
19-11-0

Plate Offsets (X,Y)--	[6:0-1-8,Edge], [7:0-1-8,Edge]
LOADING (psf)	SPACING- 2-0-0
TCLL 40.0	Plate Grip DOL 1.00
TCDL 10.0	Lumber DOL 1.00
BCLL 0.0	Rep Stress Incr YES
BCDL 5.0	Code IRC2015/TPI2014
	CSI.
	TC 0.56
	BC 0.95
	WB 0.55
	Matrix-S
	DEFL. in (loc) l/defl L/d
	Vert(LL) -0.33 18-19 >724 480
	Vert(CT) -0.45 18-19 >526 360
	Horz(CT) 0.08 14 n/a n/a
	PLATES GRIP
	MT20 244/190
	M18AHS 186/179
	Weight: 106 lb FT = 20%F, 11%E

LUMBER-

TOP CHORD 2x4 SP No.1(flat)
BOT CHORD 2x4 SP No.1(flat)
WEBS 2x4 SP No.3(flat)

BRACING-

TOP CHORD Structural wood sheathing directly applied or 5-9-6 oc purlins, except end verticals.
BOT CHORD Rigid ceiling directly applied or 2-2-0 oc bracing.

REACTIONS.

(size) 24=0-3-0, 14=0-3-0
Max Grav 24=1075(LC 1), 14=1075(LC 1)

FORCES. (lb) - Max. Comp./Max. Ten. - All forces 250 (lb) or less except when shown.

TOP CHORD 2-3=-2005/0, 3-4=-3408/0, 4-5=-3408/0, 5-6=-4160/0, 6-7=-4391/0, 7-9=-4160/0, 9-10=-3408/0, 10-11=-3408/0, 11-12=-2005/0
BOT CHORD 23-24=0/1172, 21-23=0/2810, 20-21=0/3918, 19-20=0/4391, 18-19=0/4391, 17-18=0/4391, 16-17=0/3918, 15-16=0/2810, 14-15=0/1172
WEBS 2-24=-1557/0, 2-23=0/1160, 3-23=-1119/0, 3-21=0/814, 5-21=-693/0, 5-20=0/469, 6-20=-575/87, 12-14=-1557/0, 12-15=0/1160, 11-15=-1119/0, 11-16=0/814, 9-16=-693/0, 9-17=0/469, 7-17=-575/87

NOTES-

- 1) Unbalanced floor live loads have been considered for this design.
- 2) All plates are MT20 plates unless otherwise indicated.
- 3) All plates are 1.5x3 MT20 unless otherwise indicated.
- 4) Plates checked for a plus or minus 1 degree rotation about its center.
- 5) Recommend 2x6 strongbacks, on edge, spaced at 10-0-0 oc and fastened to each truss with 3-10d (0.131" X 3") nails. Strongbacks to be attached to walls at their outer ends or restrained by other means.

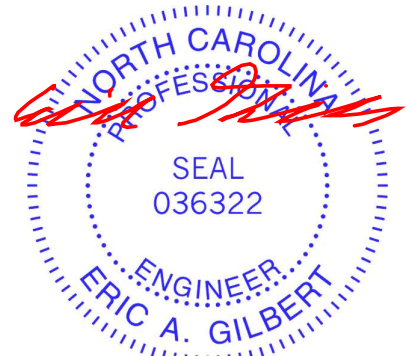

March 1, 2023

WARNING - Verify design parameters and READ NOTES ON THIS AND INCLUDED MITEK REFERENCE PAGE MII-7473 rev. 5/19/2020 BEFORE USE.

Design valid for use only with MiTek® connectors. This design is based only upon parameters shown, and is for an individual building component, not a truss system. Before use, the building designer must verify the applicability of design parameters and properly incorporate this design into the overall building design. Bracing indicated is to prevent buckling of individual truss web and/or chord members only. Additional temporary and permanent bracing is always required for stability and to prevent collapse with possible personal injury and property damage. For general guidance regarding the fabrication, storage, delivery, erection and bracing of trusses and truss systems, see **ANSI/TPI1 Quality Criteria, DSB-89 and BCSI Building Component Safety Information** available from Truss Plate Institute, 2670 Crain Highway, Suite 203 Waldorf, MD 20601



818 Soundside Road
Edenton, NC 27932

Job J0323-1215	Truss F4	Truss Type Floor	Qty 10	Ply 1	Lot 43 Liberty Meadow I56917905
-------------------	-------------	---------------------	-----------	----------	------------------------------------

Comtech, Inc. Fayetteville, NC - 28314,

8.430 s Jan 6 2022 MiTek Industries, Inc. Wed Mar 1 09:54:54 2023 Page 1
ID:aTXuLo?nW09qtpROz2WQ0wydkZW-gnfOelOpshfggD0xtv31ahK0t3hC8etil1O_LzfKAI

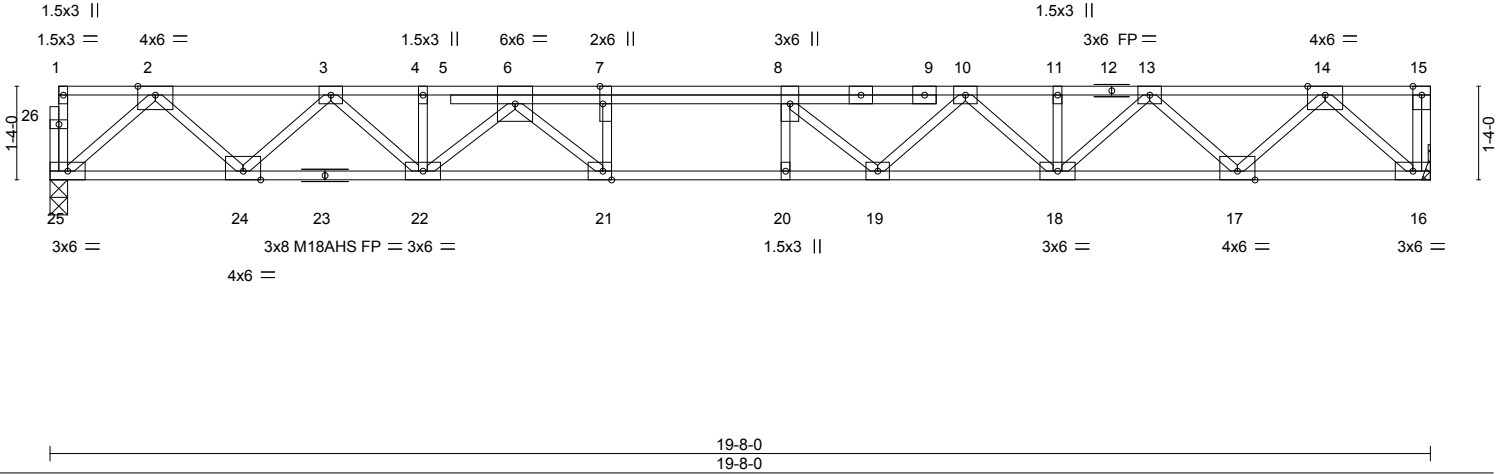

Plate Offsets (X,Y)--	[7:0-3-0,Edge], [21:0-1-8,Edge]				
LOADING (psf)	SPACING- 2-0-0	CSI.	DEFL. in (loc) l/defl L/d	PLATES	GRIP
TCLL 40.0	Plate Grip DOL 1.00	TC 0.39	Vert(LL) -0.29 20 >806 480	MT20	244/190
TCDL 10.0	Lumber DOL 1.00	BC 0.88	Vert(CT) -0.40 20 >587 360	M18AHS	186/179
BCLL 0.0	Rep Stress Incr YES	WB 0.54	Horz(CT) 0.08 16 n/a n/a		
BCDL 5.0	Code IRC2015/TPI2014	Matrix-S			
				Weight: 112 lb	FT = 20%F, 11%E

LUMBER-	BRACING-
TOP CHORD 2x4 SP No.1(flat)	TOP CHORD Structural wood sheathing directly applied or 6-0-0 oc purlins, except end verticals.
BOT CHORD 2x4 SP No.1(flat)	BOT CHORD Rigid ceiling directly applied or 10-0-0 oc bracing.
WEBS 2x4 SP No.3(flat)	

REACTIONS. (size) 25=0-3-0, 16=Mechanical
Max Grav 25=1062(LC 1), 16=1068(LC 1)

FORCES. (lb) - Max. Comp./Max. Ten. - All forces 250 (lb) or less except when shown.
TOP CHORD 2-3=-1976/0, 3-4=-3346/0, 4-6=-3350/0, 6-7=-4437/0, 7-8=-4437/0, 8-10=-4140/0, 10-11=-3354/0, 11-13=-3354/0, 13-14=-1976/0
BOT CHORD 24-25=0/1156, 22-24=0/2765, 21-22=0/3951, 20-21=0/4437, 19-20=0/4437, 18-19=0/3823, 17-18=0/2764, 16-17=0/1157
WEBS 2-25=-1537/0, 2-24=0/1140, 3-24=-1097/0, 3-22=0/790, 6-22=-803/0, 6-21=0/970, 7-21=-557/0, 14-16=-1541/0, 14-17=0/1139, 13-17=-1096/0, 13-18=0/802, 10-18=-637/0, 10-19=0/581, 8-19=-621/0

- NOTES-**
- 1) Unbalanced floor live loads have been considered for this design.
 - 2) All plates are MT20 plates unless otherwise indicated.
 - 3) All plates are 3x4 MT20 unless otherwise indicated.
 - 4) Plates checked for a plus or minus 1 degree rotation about its center.
 - 5) Refer to girder(s) for truss to truss connections.
 - 6) Recommend 2x6 strongbacks, on edge, spaced at 10-0-0 oc and fastened to each truss with 3-10d (0.131" X 3") nails. Strongbacks to be attached to walls at their outer ends or restrained by other means.
 - 7) CAUTION, Do not erect truss backwards.



March 1, 2023

<p>WARNING - Verify design parameters and READ NOTES ON THIS AND INCLUDED MITEK REFERENCE PAGE MII-7473 rev. 5/19/2020 BEFORE USE.</p> <p>Design valid for use only with MiTek® connectors. This design is based only upon parameters shown, and is for an individual building component, not a truss system. Before use, the building designer must verify the applicability of design parameters and properly incorporate this design into the overall building design. Bracing indicated is to prevent buckling of individual truss web and/or chord members only. Additional temporary and permanent bracing is always required for stability and to prevent collapse with possible personal injury and property damage. For general guidance regarding the fabrication, storage, delivery, erection and bracing of trusses and truss systems, see ANSI/TPI1 Quality Criteria, DSB-89 and BCSI Building Component Safety Information available from Truss Plate Institute, 2670 Crain Highway, Suite 203 Waldorf, MD 20601</p>	<p>818 Soundside Road Edenton, NC 27932</p>
--	---

Job J0323-1215	Truss F4A	Truss Type Floor	Qty 1	Ply 1	Lot 43 Liberty Meadow I56917906
-------------------	--------------	---------------------	----------	----------	------------------------------------

Comtech, Inc. Fayetteville, NC - 28314,

8.430 s Jan 6 2022 MiTek Industries, Inc. Wed Mar 1 09:54:56 2023 Page 1
ID:aTXuLo?nW09qtpROz2WQ0wydkZW-cAn83RQ3OlvNwXAJ_NyX6?ngOhsyg5uA9cWU3DzfKAJ

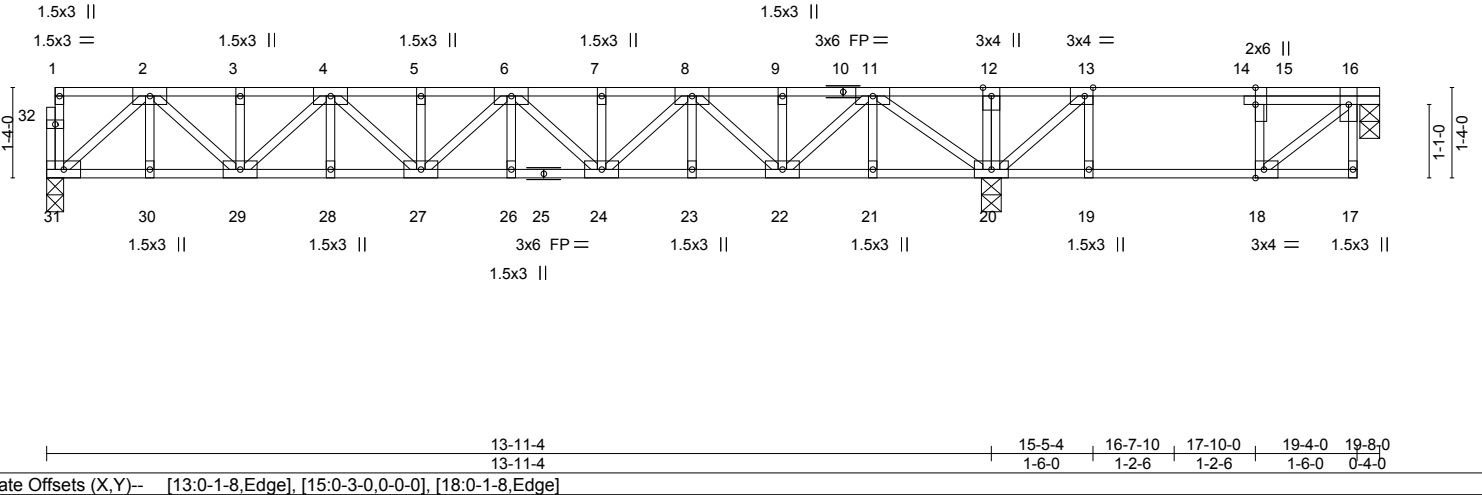

LOADING (psf)	SPACING- 2-0-0	CSI.	DEFL. in (loc) l/defl L/d	PLATES	GRIP
TCLL 40.0	Plate Grip DOL 1.00	TC 0.40	Vert(LL) -0.08 26 >999 480	MT20	244/190
TCDL 10.0	Lumber DOL 1.00	BC 0.38	Vert(CT) -0.11 26 >999 360		
BCLL 0.0	Rep Stress Incr YES	WB 0.37	Horz(CT) 0.03 20 n/a n/a		
BCDL 5.0	Code IRC2015/TPI2014	Matrix-S		Weight: 115 lb	FT = 20%F, 11%E

LUMBER-	BRACING-
TOP CHORD 2x4 SP No.1(flat)	TOP CHORD Structural wood sheathing directly applied or 6-0-0 oc purlins, except end verticals.
BOT CHORD 2x4 SP No.1(flat)	BOT CHORD Rigid ceiling directly applied or 10-0-0 oc bracing, Except: 6-0-0 oc bracing: 19-20,18-19.
WEBS 2x4 SP No.3(flat)	

REACTIONS. (size) 31=0-3-0, 16=0-3-8, 20=0-3-8
Max Grav 31=730(LC 8), 16=275(LC 4), 20=1157(LC 7)

FORCES. (lb) - Max. Comp./Max. Ten. - All forces 250 (lb) or less except when shown.
TOP CHORD 2-3=-1331/0, 3-4=-1331/0, 4-5=-1969/0, 5-6=-1969/0, 6-7=-1961/0, 7-8=-1961/0, 8-9=-1306/0, 9-11=-1306/0, 11-12=0/365, 12-13=0/364, 13-15=-276/99, 15-16=-253/96
BOT CHORD 30-31=0/775, 29-30=0/775, 28-29=0/1732, 27-28=0/1732, 26-27=0/2047, 24-26=0/2047, 23-24=0/1717, 22-23=0/1717, 21-22=0/750, 20-21=0/750, 19-20=-96/253, 18-19=-96/253
WEBS 16-18=-125/330, 2-31=-1021/0, 2-29=0/751, 4-29=-541/0, 4-27=0/319, 8-24=0/345, 8-22=-569/0, 11-22=0/769, 11-20=-1229/0, 13-20=-575/0

- NOTES-**
- 1) Unbalanced floor live loads have been considered for this design.
 - 2) All plates are 3x6 MT20 unless otherwise indicated.
 - 3) Plates checked for a plus or minus 1 degree rotation about its center.
 - 4) Recommend 2x6 strongbacks, on edge, spaced at 10-0-0 oc and fastened to each truss with 3-10d (0.131" X 3") nails. Strongbacks to be attached to walls at their outer ends or restrained by other means.
 - 5) Gap between inside of top chord bearing and first diagonal or vertical web shall not exceed 0.500in.
 - 6) CAUTION, Do not erect truss backwards.

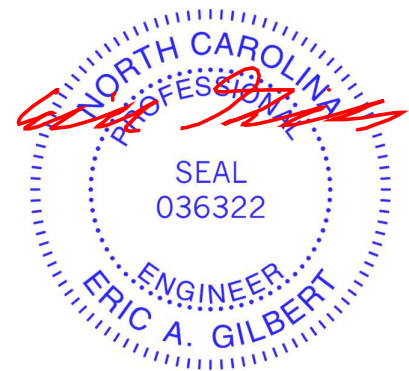

Job J0323-1215	Truss F5	Truss Type FLOOR	Qty 1	Ply 1	Lot 43 Liberty Meadow Job Reference (optional)	I56917907
-------------------	-------------	---------------------	----------	----------	---	-----------

Comtech, Inc. Fayetteville, NC - 28314,

8.430 s Jan 6 2022 MiTek Industries, Inc. Wed Mar 1 09:54:57 2023 Page 1

ID:aTXuLo?nW09qtpROz2WQ0wydkZW-4MLWHnRi8c1EXhIVY5TmeDJun5GPPb0JOGG2bgzfKAI

0-1-8

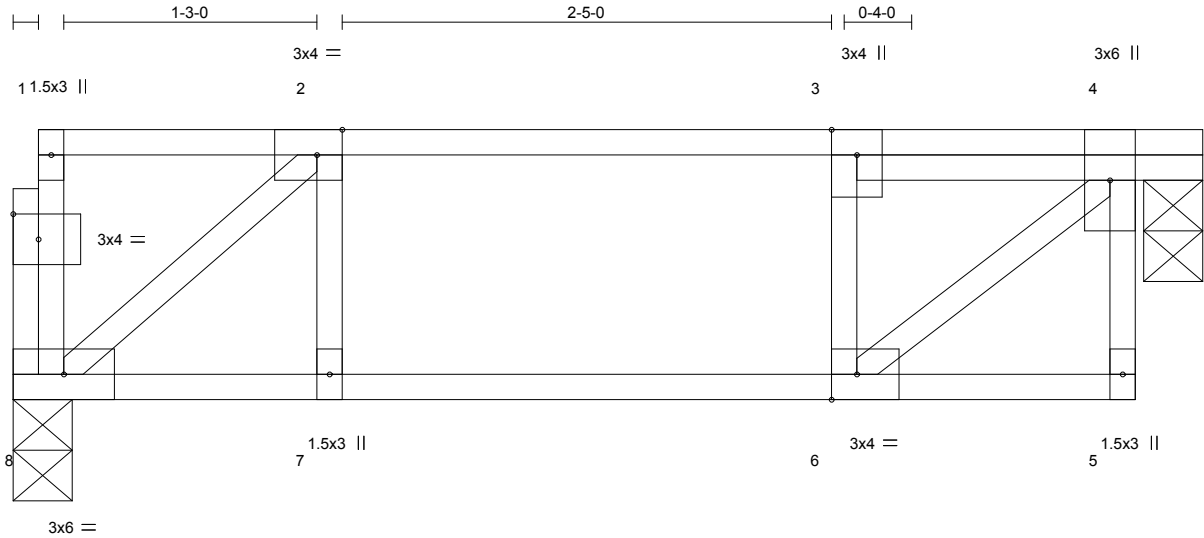

Scale = 1:11.4

Plate Offsets (X,Y)--	[2:0-1-8,Edge], [6:0-1-8,Edge], [9:0-1-8,0-1-8]				
LOADING (psf)	SPACING- 2-0-0	CSI.	DEFL. in (loc) l/defl L/d	PLATES	GRIP
TCLL 40.0	Plate Grip DOL 1.00	TC 0.23	Vert(LL) -0.01 6 >999 480	MT20	244/190
TCDL 10.0	Lumber DOL 1.00	BC 0.11	Vert(CT) -0.01 6 >999 360		
BCLL 0.0	Rep Stress Incr YES	WB 0.18	Horz(CT) -0.01 4 n/a n/a		
BCDL 5.0	Code IRC2015/TPI2014	Matrix-S		Weight: 32 lb	FT = 20%F, 11%E

LUMBER-	BRACING-
TOP CHORD 2x4 SP No.1(flat)	TOP CHORD Structural wood sheathing directly applied or 5-10-8 oc purlins, except end verticals.
BOT CHORD 2x4 SP No.1(flat)	BOT CHORD Rigid ceiling directly applied or 10-0-0 oc bracing.
WEBS 2x4 SP No.3(flat)	

REACTIONS. (size) 8=0-3-8, 4=0-3-8
Max Grav 8=288(LC 1), 4=294(LC 1)

FORCES. (lb) - Max. Comp./Max. Ten. - All forces 250 (lb) or less except when shown.
TOP CHORD 2-3=-294/0, 3-4=-296/0
BOT CHORD 7-8=0/294, 6-7=0/294
WEBS 2-8=-382/0, 4-6=0/383

- NOTES-**
- 1) Unbalanced floor live loads have been considered for this design.
 - 2) Plates checked for a plus or minus 1 degree rotation about its center.
 - 3) Recommend 2x6 strongbacks, on edge, spaced at 10-0-0 oc and fastened to each truss with 3-10d (0.131" X 3") nails. Strongbacks to be attached to walls at their outer ends or restrained by other means.
 - 4) Gap between inside of top chord bearing and first diagonal or vertical web shall not exceed 0.500in.
 - 5) CAUTION, Do not erect truss backwards.

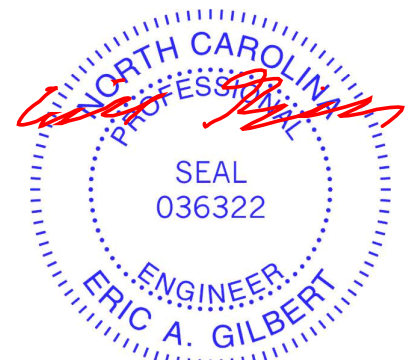

March 1, 2023

Job J0323-1215	Truss FG1	Truss Type FLOOR	Qty 1	Ply 1	Lot 43 Liberty Meadow Job Reference (optional)	I56917908
-------------------	--------------	---------------------	----------	----------	---	-----------

Comtech, Inc. Fayetteville, NC - 28314,

8.430 s Jan 6 2022 MiTek Industries, Inc. Wed Mar 1 09:54:58 2023 Page 1

ID:aTXuLo?nW09qtpROz2WQ0wydkZW-ZYvvU7RkVv959qKi6o_?BQs5FVbp82BTdw?b76zfKAh

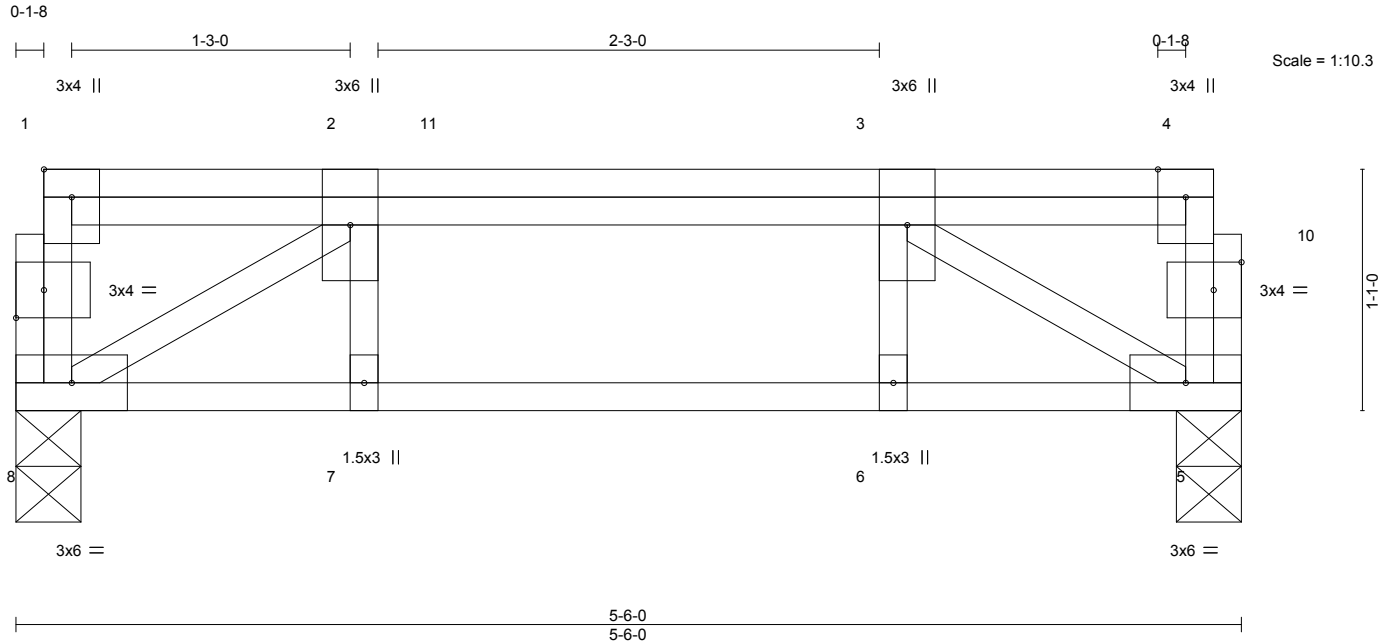

Plate Offsets (X,Y)-- [1:Edge,0-1-8], [9:0-1-8,0-1-8], [10:0-1-8,0-1-8]

LOADING (psf)	SPACING-	2-0-0	CSI.	DEFL.	in (loc)	l/defl	L/d	PLATES	GRIP
TCLL 40.0	Plate Grip DOL	1.00	TC 0.12	Vert(LL)	-0.01	6	>999	MT20	244/190
TCDL 10.0	Lumber DOL	1.00	BC 0.17	Vert(CT)	-0.01	6-7	>999		
BCLL 0.0	Rep Stress Incr	NO	WB 0.19	Horz(CT)	0.01	5	n/a		
BCDL 5.0	Code IRC2015/TPI2014		Matrix-S						
								Weight: 34 lb	FT = 20%F, 11%E

LUMBER-	BRACING-
TOP CHORD 2x4 SP No.1(flat)	TOP CHORD Structural wood sheathing directly applied or 5-6-0 oc purlins, except end verticals.
BOT CHORD 2x4 SP No.1(flat)	BOT CHORD Rigid ceiling directly applied or 10-0-0 oc bracing.
WEBS 2x4 SP No.3(flat)	

REACTIONS. (size) 8=0-3-8, 5=0-3-8
Max Grav 8=455(LC 1), 5=476(LC 1)

FORCES. (lb) - Max. Comp./Max. Ten. - All forces 250 (lb) or less except when shown.
TOP CHORD 2-3=-683/0
BOT CHORD 7-8=0/683, 6-7=0/683, 5-6=0/683
WEBS 2-8=-802/0, 3-5=-801/0

NOTES-
1) Unbalanced floor live loads have been considered for this design.
2) Plates checked for a plus or minus 1 degree rotation about its center.
3) Recommend 2x6 strongbacks, on edge, spaced at 10-0-0 oc and fastened to each truss with 3-10d (0.131" X 3") nails. Strongbacks to be attached to walls at their outer ends or restrained by other means.

LOAD CASE(S) Standard
1) Dead + Floor Live (balanced): Lumber Increase=1.00, Plate Increase=1.00
Uniform Loads (plf)
Vert: 5-8=-10, 1-4=-100
Concentrated Loads (lb)
Vert: 3=-172 11=-194

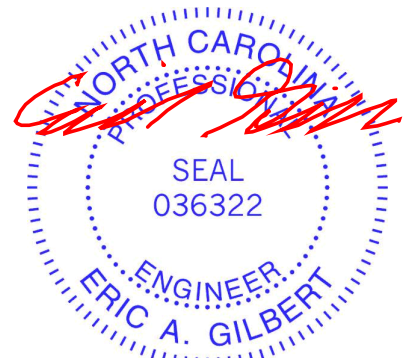

March 1, 2023

WARNING - Verify design parameters and READ NOTES ON THIS AND INCLUDED MITEK REFERENCE PAGE MII-7473 rev. 5/19/2020 BEFORE USE.

Design valid for use only with MiTek® connectors. This design is based only upon parameters shown, and is for an individual building component, not a truss system. Before use, the building designer must verify the applicability of design parameters and properly incorporate this design into the overall building design. Bracing indicated is to prevent buckling of individual truss web and/or chord members only. Additional temporary and permanent bracing is always required for stability and to prevent collapse with possible personal injury and property damage. For general guidance regarding the fabrication, storage, delivery, erection and bracing of trusses and truss systems, see **ANSI/TPI1 Quality Criteria, DSB-89 and BCSI Building Component Safety Information** available from Truss Plate Institute, 2670 Crain Highway, Suite 203 Waldorf, MD 20601



818 Soundside Road
Edenton, NC 27932

Symbols

PLATE LOCATION AND ORIENTATION

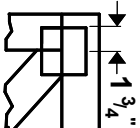

Center plate on joint unless x, y offsets are indicated. Dimensions are in ft-in-sixteenths. Apply plates to both sides of truss and fully embed teeth.

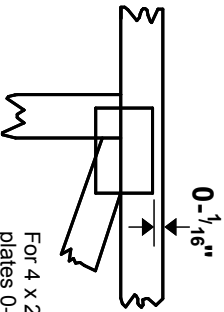

For 4 x 2 orientation, locate plates 0- 1/16" from outside edge of truss.



This symbol indicates the required direction of slots in connector plates.

* Plate location details available in **MITek 20/20 software** or upon request.

PLATE SIZE

4 X 4

The first dimension is the plate width measured perpendicular to slots. Second dimension is the length parallel to slots.

LATERAL BRACING LOCATION



Indicated by symbol shown and/or by text in the bracing section of the output. Use T or I bracing if indicated.

BEARING



Indicates location where bearings (supports) occur. Icons vary but reaction section indicates joint number where bearings occur. Min size shown is for crushing only.

Industry Standards:

ANSI/TFP 1: National Design Specification for Metal Plate Connected Wood Truss Construction.
DSB-89: Design Standard for Bracing.
BCSI: Building Component Safety Information, Guide to Good Practice for Handling, Installing & Bracing of Metal Plate Connected Wood Trusses.

Numbering System

6-4-8 dimensions shown in ft-in-sixteenths (Drawings not to scale)

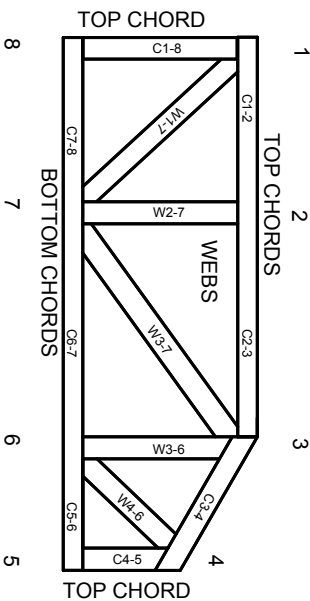

JOINTS ARE GENERALLY NUMBERED/LETTERED CLOCKWISE AROUND THE TRUSS STARTING AT THE JOINT FARTHEST TO THE LEFT.

CHORDS AND WEBS ARE IDENTIFIED BY END JOINT NUMBERS/LETTERS.

PRODUCT CODE APPROVALS

ICC-ES Reports:

ESR-1311, ESR-1352, ESR1988
ER-3907, ESR-2362, ESR-1397, ESR-3282

Trusses are designed for wind loads in the plane of the truss unless otherwise shown.

Lumber design values are in accordance with ANSI/TFP 1 section 6.3 These truss designs rely on lumber values established by others.

© 2012 MITteK® All Rights Reserved



MITek Engineering Reference Sheet: Mill-7473 rev. 5/19/2020



General Safety Notes

Failure to Follow Could Cause Property Damage or Personal Injury

1. Additional stability bracing for truss system, e.g. diagonal or X-bracing, is always required. See BCSI.
2. Truss bracing must be designed by an engineer. For wide truss spacing, individual lateral braces themselves may require bracing, or alternative Tor I bracing should be considered.
3. Never exceed the design loading shown and never stack materials on inadequately braced trusses.
4. Provide copies of this truss design to the building designer, erection supervisor, property owner and all other interested parties.
5. Cut members to bear tightly against each other.
6. Place plates on each face of truss at each joint and embed fully. Knots and wane at joint locations are regulated by ANSI/TFP 1.
7. Design assumes trusses will be suitably protected from the environment in accord with ANSI/TFP 1.
8. Unless otherwise noted, moisture content of lumber shall not exceed 19% at time of fabrication.
9. Unless expressly noted, this design is not applicable for use with fire retardant, preservative treated, or green lumber.
10. Camber is a non-structural consideration and is the responsibility of truss fabricator. General practice is to camber for dead load deflection.
11. Plate type, size, orientation and location dimensions indicated are minimum plating requirements.
12. Lumber used shall be of the species and size, and in all respects, equal to or better than that specified.
13. Top chords must be sheathed or purlins provided at spacing indicated on design.
14. Bottom chords require lateral bracing at 10 ft. spacing, or less, if no ceiling is installed, unless otherwise noted.
15. Connections not shown are the responsibility of others.
16. Do not cut or alter truss member or plate without prior approval of an engineer.
17. Install and load vertically unless indicated otherwise.
18. Use of green or treated lumber may pose unacceptable environmental, health or performance risks. Consult with project engineer before use.
19. Review all portions of this design (front, back, words and pictures) before use. Reviewing pictures alone is not sufficient.
20. Design assumes manufacture in accordance with ANSI/TFP 1 Quality Criteria.
21. The design does not take into account any dynamic or other loads other than those expressly stated.