

Job 72318344REP1	Truss B1	Truss Type Truss	Qty 9	Ply 1	LGI/AVERY PLAN RF Job Reference (optional)
---------------------	-------------	---------------------	----------	----------	---

UFP Mid Atlantic LLC, 5631 S. NC 62, Burlington, NC, Kelly Langley

Run: 8.33 S Apr 7 2020 Print: 8.620 S Sep 22 2022 MiTek Industries, Inc. Tue Jul 18 15:51:05

Page: 1

ID:SO88tv2haJLv5XjhL_jc?lyMauL-8ffoCUq9DNyk3vOIO4llabFWUllpsY4PuZ5VC4ywoVK

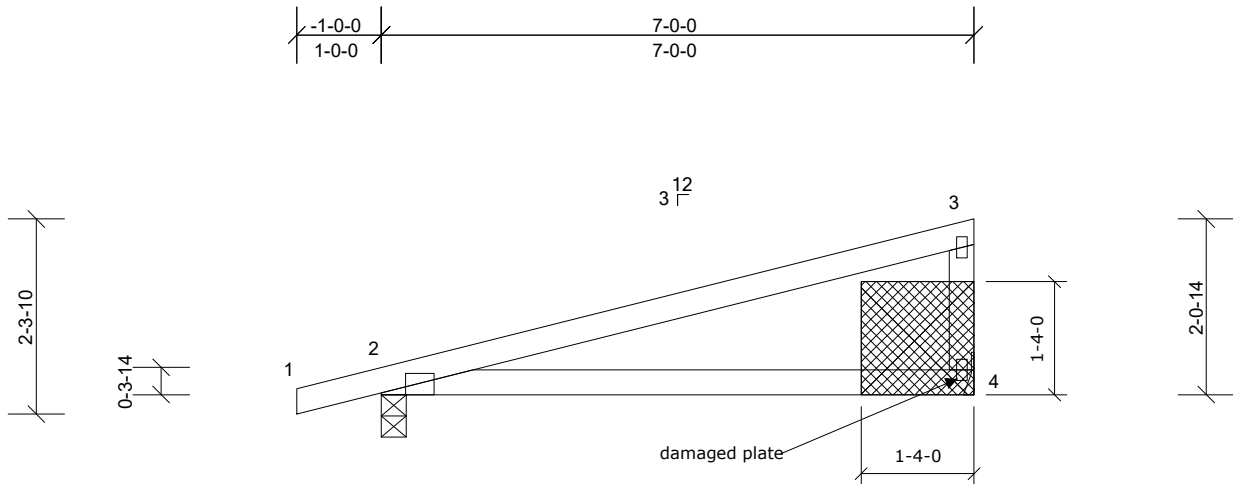

Repair for a damaged plate as shown.

Attach 7/16 in. OSB (APA Rated Sheathing 24/16 Exposure 1) gusset to both sides of truss as shown with two rows of 10d (.131" x 3") nails 4" oc in all members from each face, driven through both sheets of plywood.

Plate Offsets (X, Y): [2:0-3-7,Edge]

Loading	(psf)	Spacing	2-0-0	CSI	DEFL	in	(loc)	l/defl	L/d	PLATES	GRIP
TCLL (roof)	20.0	Plate Grip DOL	1.15	TC	Vert(LL)	0.11	4-7	>734	240	MT20	244/190
TCDL	10.0	Lumber DOL	1.15	BC	Vert(CT)	-0.23	4-7	>358	180		
BCLL	0.0 *	Rep Stress Incr	YES	WB	Horz(CT)	0.00	2	n/a	n/a		
BCDL	10.0	Code	IRC2015/TPI2014	Matrix-MP						Weight: 25 lb	FT = 20%

LUMBER	BRACING
TOP CHORD 2x4 SP No.2	TOP CHORD Structural wood sheathing directly applied or 7-0-0 oc purlins, except end verticals.
BOT CHORD 2x4 SP No.2	BOT CHORD Rigid ceiling directly applied or 10-0-0 oc bracing.
WEBS 2x4 SP No.3	

REACTIONS	(lb/size)	2=339(0-3-8, (min. 0-1-8), 4=270/ Mechanical, (min. 0-1-8)
Max Horiz	2=79 (LC 9)	
Max Uplift	2=97 (LC 6), 4=59 (LC 10)	

↑ FORCES (lb) - Max. Comp./Max. Ten. - All forces 250 (lb) or less except when shown.

- NOTES (6)**
- 1) Wind: ASCE 7-10; Vult=130mph (3-second gust) Vasd=103mph; TCCL=6.0psf; BCDL=6.0psf; h=35ft; Cat. II; Exp B; Enclosed; MWFRS (envelope) exterior zone and C-C Exterior (2) zone; cantilever left and right exposed; end vertical left and right exposed; C-C for members and forces & MWFRS for reactions shown; Lumber DOL=1.60 plate grip DOL=1.60
 - 2) This truss has been designed for a 10.0 psf bottom chord live load nonconcurrent with any other live loads.
 - 3) * This truss has been designed for a live load of 20.0psf on the bottom chord in all areas where a rectangle 3-06-00 tall by 2-00-00 wide will fit between the bottom chord and any other members.
 - 4) Provide mechanical connection (by others) of truss to bearing plate capable of withstanding 59 lb uplift at joint 4 and 97 lb uplift at joint 2.
 - 5) This truss is designed in accordance with the 2015 International Residential Code sections R502.11.1 and R802.10.2 and referenced standard ANSI/TPI 1.
 - 6) This repair has been prepared based on information and use conditions supplied by client. Designer has made a good faith effort to outline damage and repair conditions as reported by client. When actual field conditions do not approximate those indicated on this drawing, client shall immediately inform the engineer and refrain from applying the repair.



This design is based upon parameters shown, and is for an individual building component to be installed and loaded vertically. Applicability of design parameters and proper incorporation of component is responsibility of the Building Designer. Building Designer shall verify all design information on this sheet for conformance with conditions and requirements of the specific building and governing codes and ordinances. Building Designer accepts responsibility for the correctness or accuracy of the design information as it may relate to a specific building. Certification is valid only when truss is fabricated by a UFPI plant. Bracing shown is for lateral support of truss members only and does not replace erection and permanent bracing. Refer to Building Component Safety Information (BCSI) for general guidance regarding storage, erection and bracing available from SBCA and Truss Plate Institute.

