

PLAN:
Mises



FRONT ELEVATION

Scale: 1/4" = 1'0"

9'0" CEILING HEIGHT FIRST FLOOR
(HEADER HEIGHT 7'6")
8'0" CEILING HEIGHT SECOND FLOOR
(HEADER HEIGHT 7')

FRAME WINDOWS TO HEADER HEIGHT

SHEET TITLE:

ELEVATIONS

PROJECT ADDRESS:
126 Sears Dr. (Lot 25)



LEFT ELEVATION

Scale: 1/8" = 1'0"



RIGHT ELEVATION

Scale: 1/8" = 1'0"



REAR ELEVATION

Scale: 1/8" = 1'0"

DESIGNED BY:

Precision Custom Homes
Raeferd, NC
Shaun@PrecisionCustomHomesNC.com

DATE:

3/2/23

SCALE:

1/4" = 1'

SHEET:

A-1

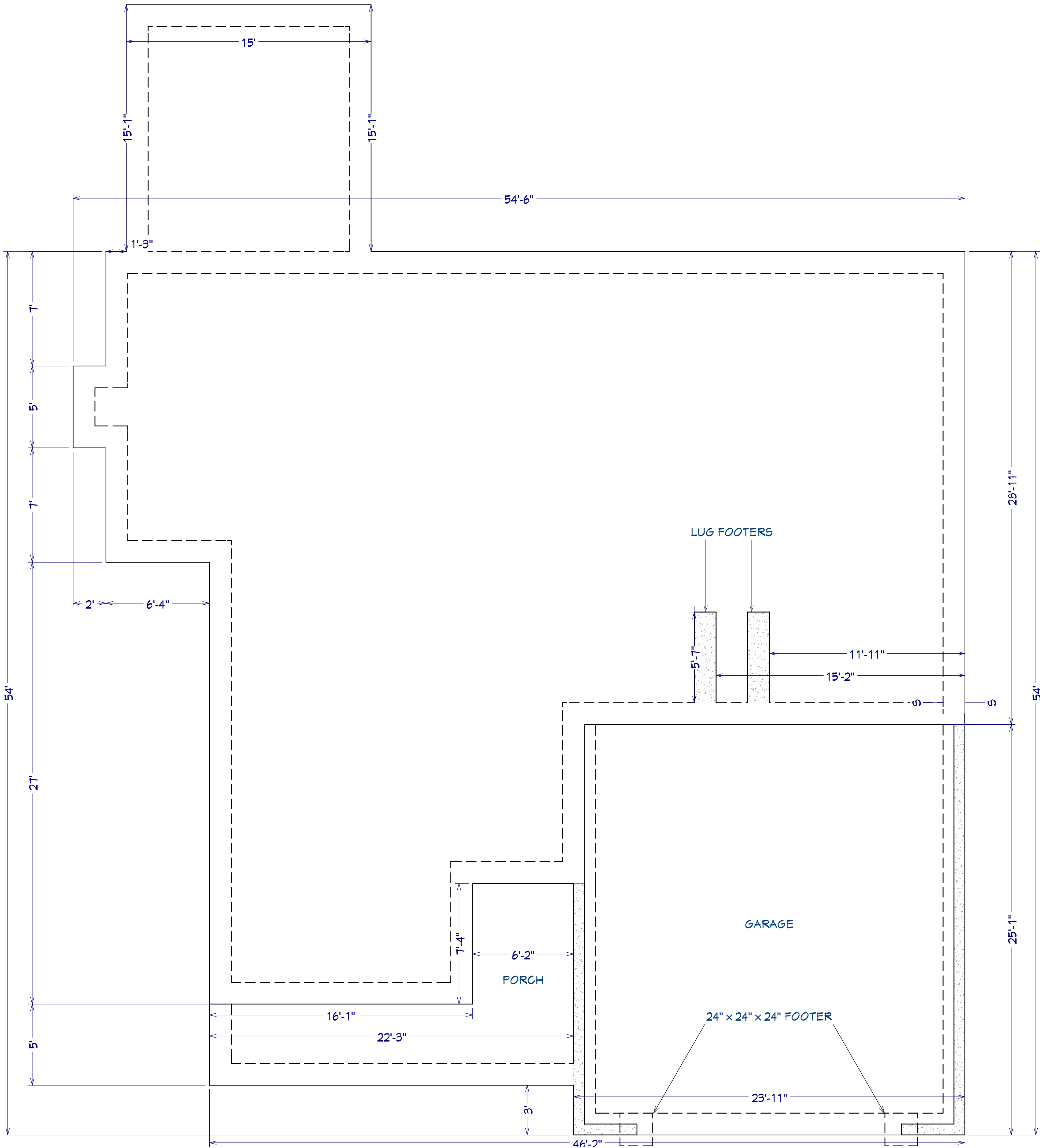

AREA SCHEDULE	
1ST FLOOR AREA	1,785 SF
2ND FLOOR AREA	646 SF
TOTAL HEATED AREA	2,431 SF
GARAGE	606 SF
FRONT PORCH	156 SF
REAR PORCH	100 SF
TOTAL AREA UNDER ROOF	3,293 SF

FOUNDATION PLAN
Scale: 1/4" = 1'0"

PLAN:
Mises

SHEET TITLE:
FOUNDATION

PROJECT ADDRESS:
126 Sears Dr. (Lot 25)

DESIGNED BY:
Precision Custom Homes
RaeFord, NC
Shaun@PrecisionCustomHomesNC.com

DATE:
3/2/23

SCALE:
1/4" = 1'

SHEET:
A-2

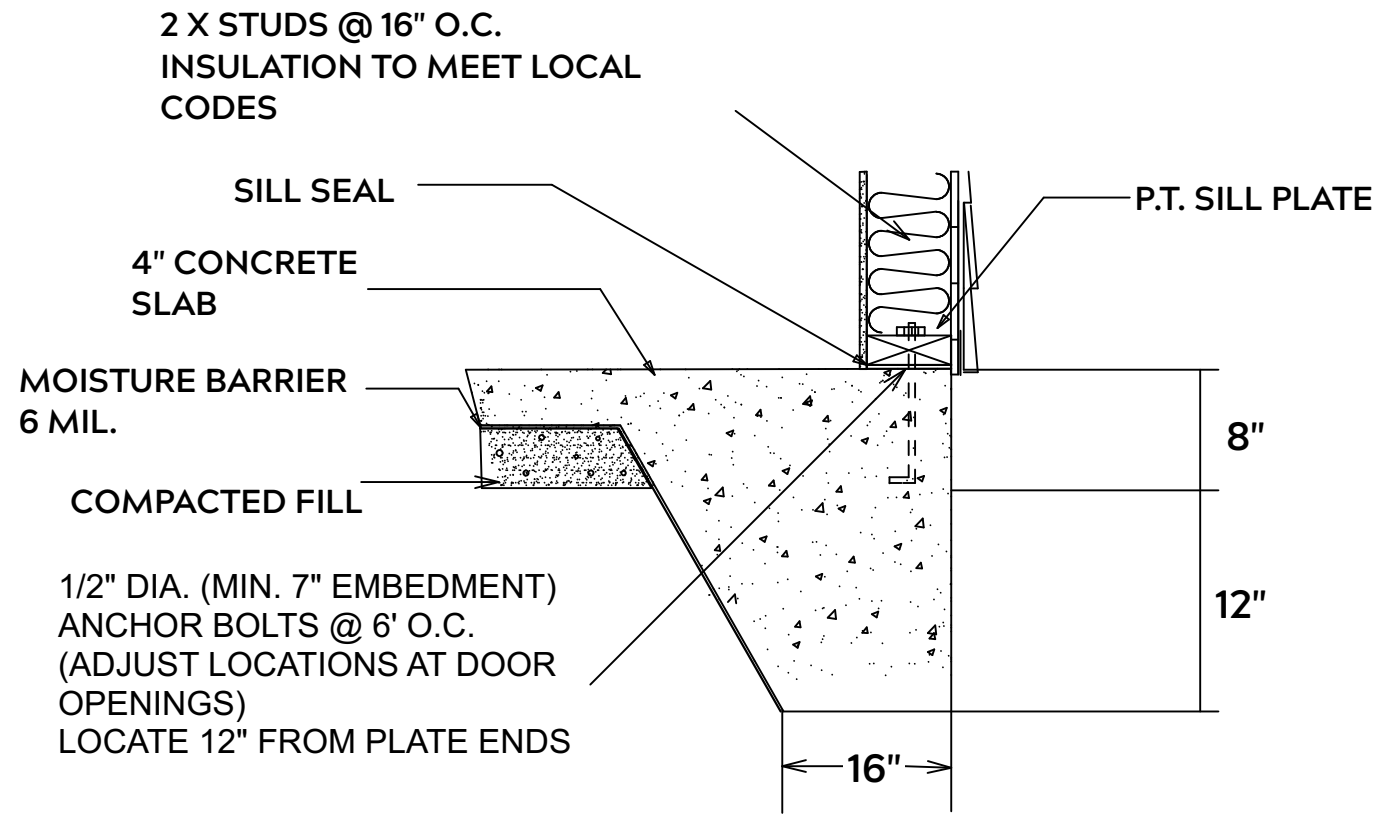

MONOLITHIC SLAB

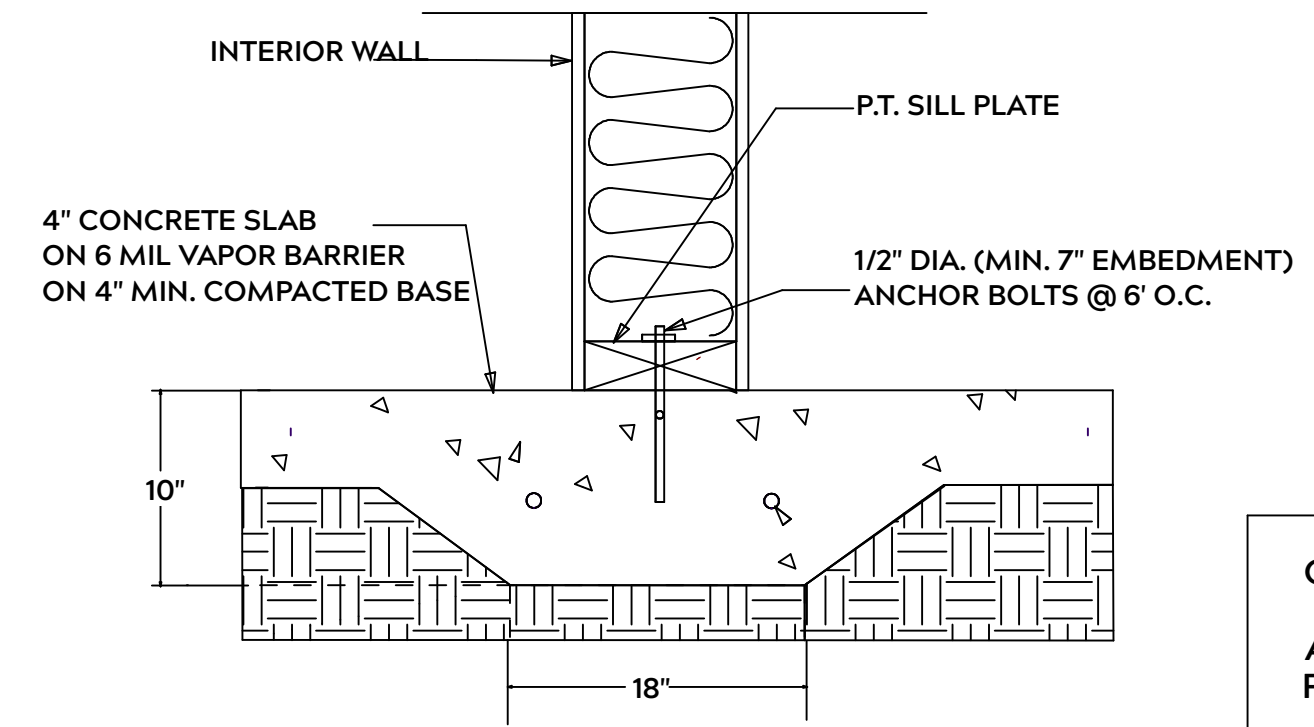

LUG FOOTING

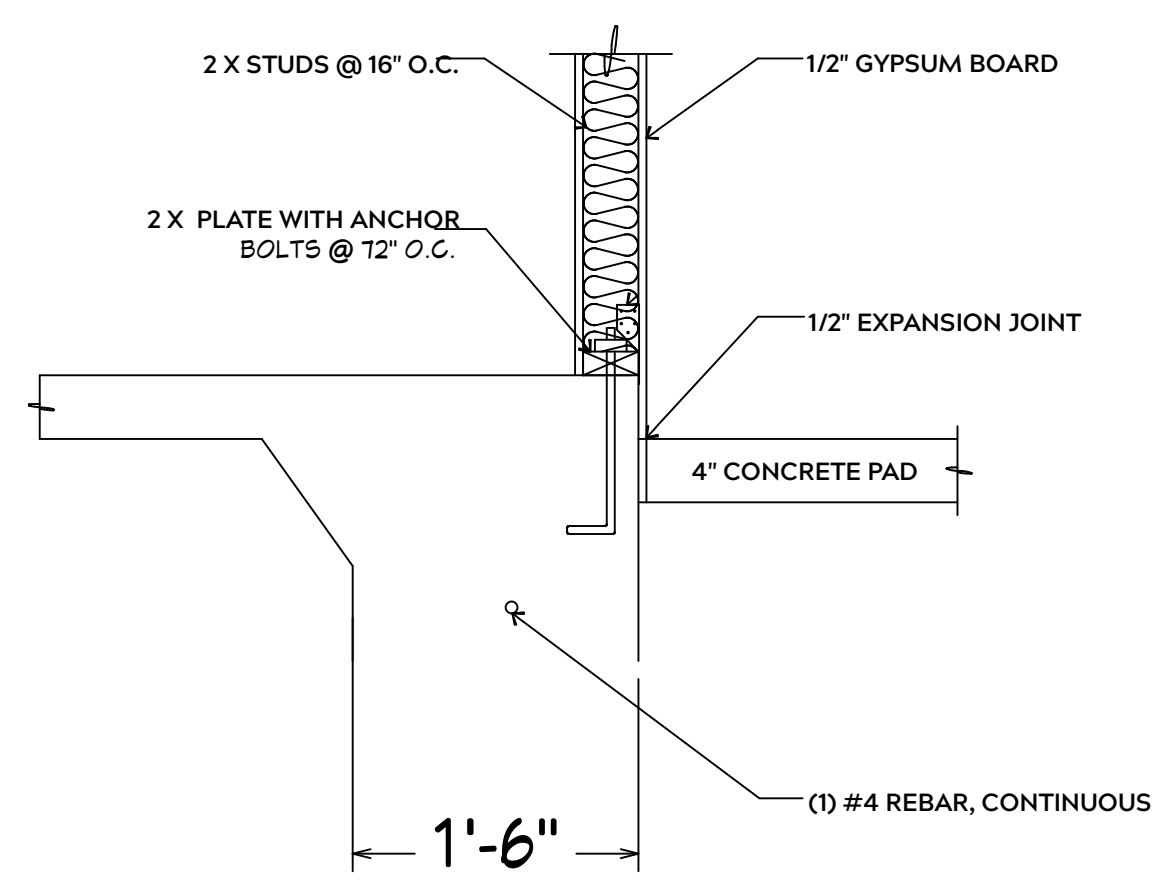

INTERIOR WALL @ GARAGE STEP DOWN

FOUNDATION NOTES:

ALL FOOTINGS SHALL BEAR ON ORIGINAL UNDISTURBED SOIL
 THE 28 DAY COMPRESSIVE STRENGTH OF ALL FOOTINGS IS 3000 PSI

PROVIDE WATER PROOFING AND PERIMTER DRAINS AS REQUIRED

FOOTING WIDTHS ARE BASED ON A LOAD BEARING SOIL CAPACITY OF 2000 PSI

PROVIDE 6 MIL POLY VAPOR BARRIER TO COVER GROUND IN CRAWL SPACE AND GROUND UNDER POURED CONCRETE

ALL ANCHOR BOLTS TO BE 1/2" X 12" LONG. ANCHOR BOLTS SHALL BE SPACED AT A MAXIMUM OF 6' ON CENTER AND NO MORE THEN 1' FROM EACH CORNER

GENERAL FRAMING NOTES:

ALL LUMBER IN CONTACT WITH CONCRETE OR MASONRY SHALLE BE PRESSURE TREATED

FRAMING LUMBER SHALL BE SYP #2 GRADE AND / OR SPRUCE PINE FIR #1 AND / OR KILN DRIED

WHERE PRE-ENGINEERED JOISTS AND TRUSSES ARE USED, MANUFACTURER SHALL PROVIDE DRAWINGS / SCHEMATICS, WHICH SHALL BEAR OF A N.C. ENGINEER

STUDS AND JOISTS SHALL NOT BE CUT TO INSTALL PLUMBING OR WIRING WITHOUT ADDING METAL OR WOOD SIDE PANELS TO STRENGTHEN MEMBER TO ITS ORIGINAL CAPACITY

NAIL MULTIPLE MEMBERS WITH 2 ROWS OF 16d NAILS STAGGERED 32" O.C. AND USE 3 X 16d NAILS 2" IN AT EACH END.

NAIL FLOOR JOISTS TO SILL PLATE WITH WITH 8d TOE NAILS

ALL EXPOSED FRAMING ON PORCHES OR DECKS SHALL BE PRESSURE TREATED

PROVIDE WATERPROOFING AND DRAINS AS REQUIRED

ALL FRAMING TO BE 16" O.C. WALL FRAMING DIMENSIONS ARE BASED ON 2X4 OR 2X6 EXTERIOR WALLS AND 2X4 INTERIOR WALLS. DOULBE / TRIPLE JACK STUDS AS NECESSARY UNDER HEADERS AS REQUIRED

LVL'S TO BE SIZED BY OTHERS (TRUSS MANUFACTURER)

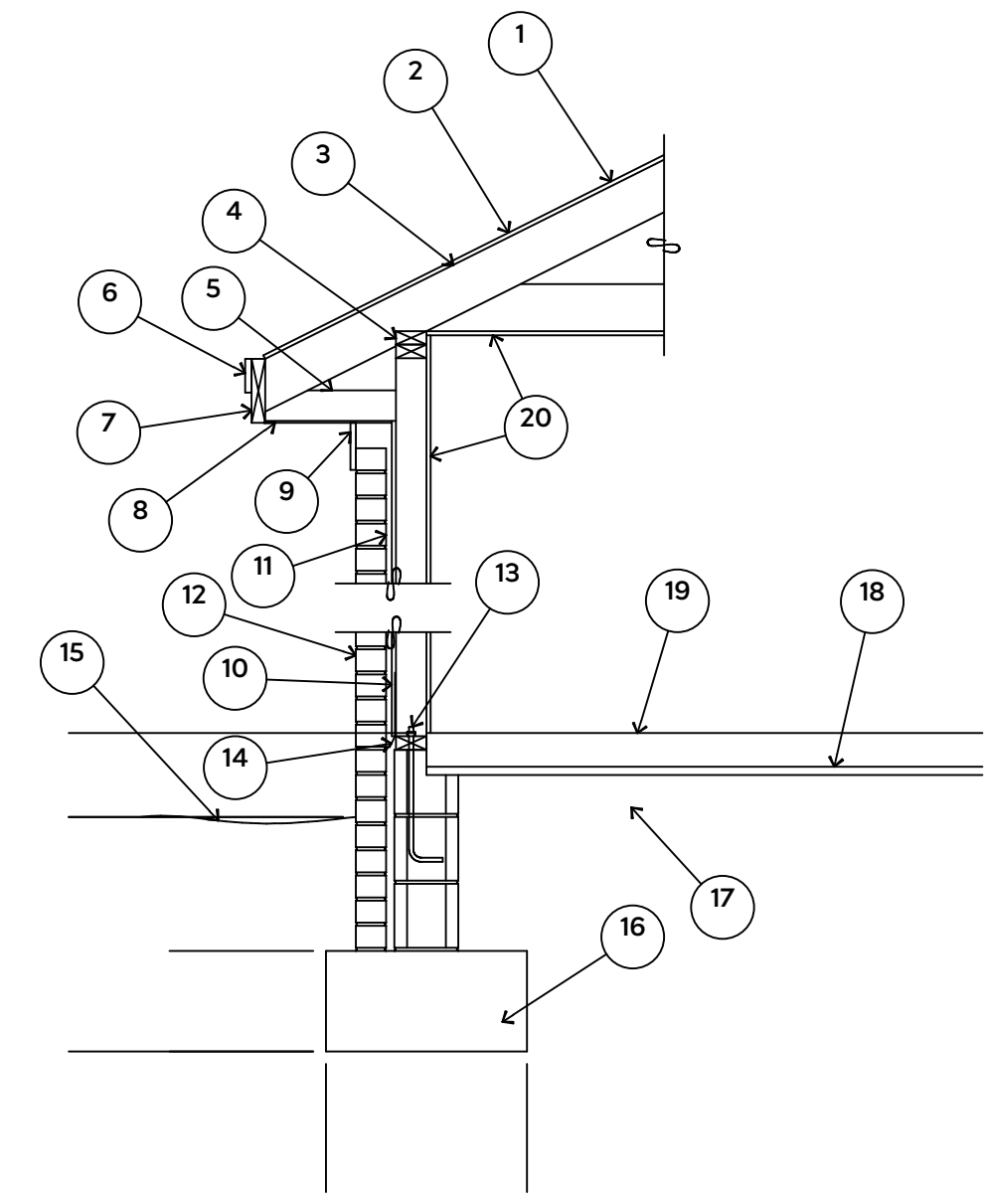

EXTERIOR WALL SECTION

1. 15# FELT UNDERLAYMENT UNDER COMPOSITION SHINGLES.
2. ROOF DECKING.
3. 2 X RAFTERS / ENGINEERED TRUSSES
4. DOUBLE TOP PLATE.
5. 2 X 4 RETURN.
6. 3/4" FASCIA OR PVC TRIM COIL
7. 2 X FASCIA
8. 1/4" PLYWOOD OR VINYL SOFFIT
9. 1 X FREIZE BOARD (TO BE USED WITH BRICK VENEERS)
10. INSULATION BOARD OR HOUSE WRAP
11. AIR SPACE.
12. BRICK WITH BRICK TIES PER MANUFACTURER'S SPECIFICATIONS.
13. 1/2" X 12" ANCHOR BOLTS, 6'-0" O.C., 12" FROM CORNERS.
14. FLASHING WITH WEEP HOLES @ 48" O.C.
15. FINISHED GRADE.
16. FOOTING
17. COMPACTED EARTH FILL.
18. 6 MIL. VAPOR BARRIER
19. 4" CONCRETE SLAB, 3,000 P.S.I. WITH 6" X 6" 10 GA. X 10 GA. WELDED WIRE FABRIC.
20. 1/2" GYPSUM BOARD.

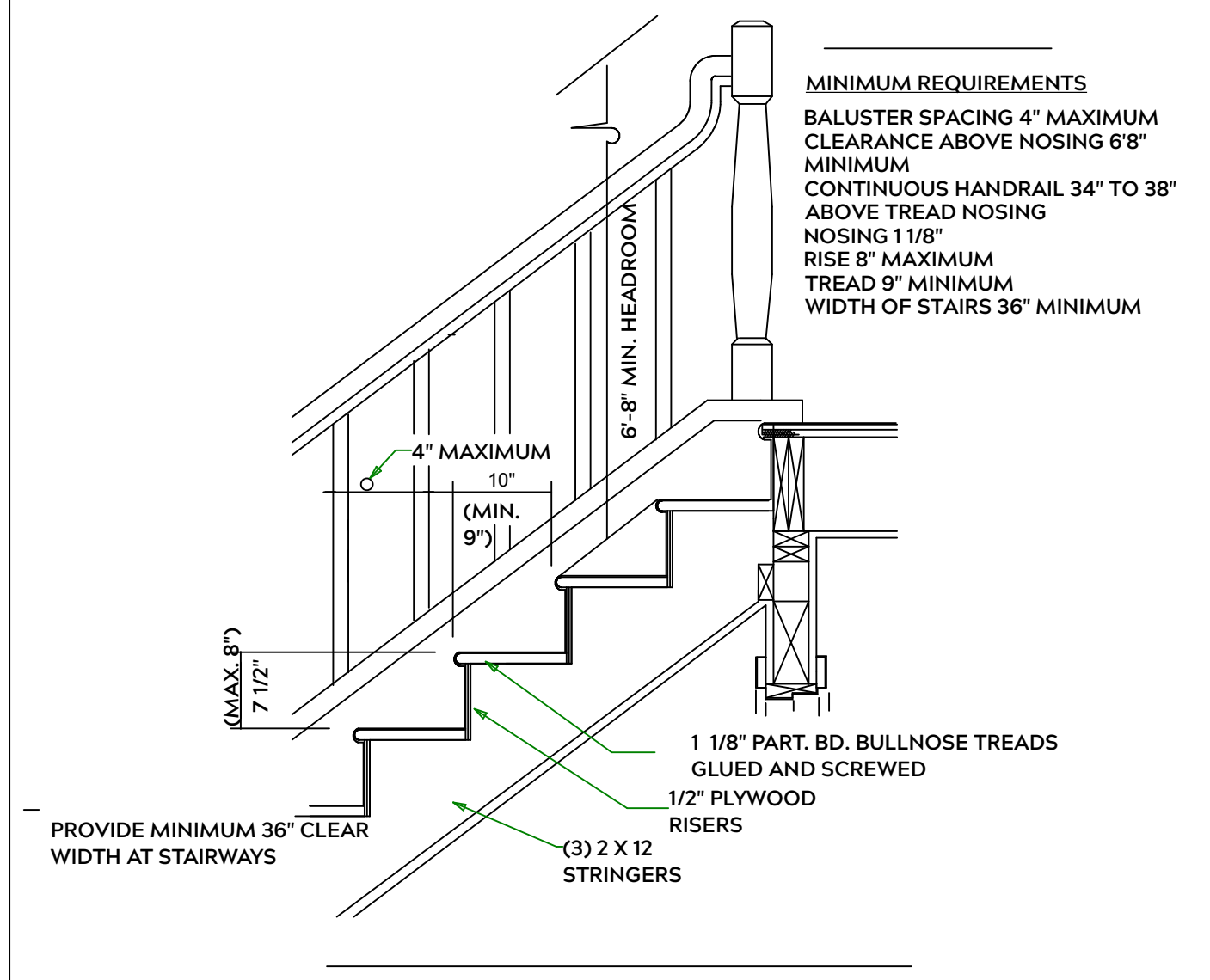

STAIR DETAIL

PLAN:
Mises

SHEET TITLE:
DETAIL SHEETS

PROJECT ADDRESS:
126 Sears Dr. (Lot 25)

DESIGNED BY:
Precision Custom Homes
Rae ford, NC
Shaun@PrecisionCustomHomesNC.com

DATE:

3/2/23

SCALE:

1/4" = 1'

SHEET:

A-3

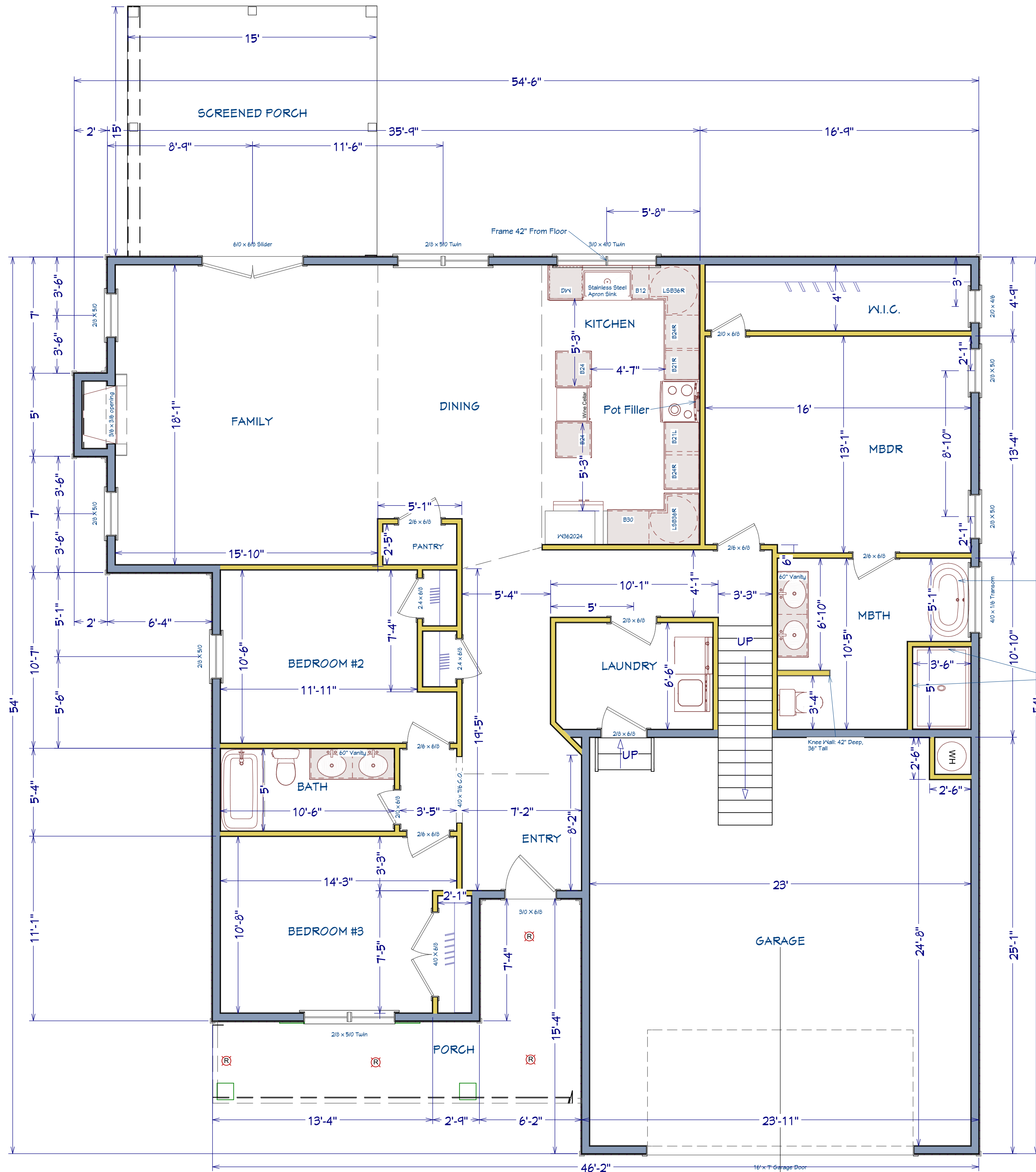

Free standing tub w/ wall mounted tub filler (centered under window)

Install Extra Delta Universal R/I Valve for 3 Way Diverter and Rain Shower Head

Triple Stud Shower Curb (PT)

AREA SCHEDULE	
1ST FLOOR AREA	1,785 SF
2ND FLOOR AREA	646 SF
TOTAL HEATED AREA	2,431 SF
GARAGE	606 SF
FRONT PORCH	156 SF
REAR PORCH	100 SF
TOTAL AREA UNDER ROOF	3,243 SF

PLAN:
Mises

SHEET TITLE:
1st FLOOR

PROJECT ADDRESS:
126 Sears Dr. (Lot 25)

DESIGNED BY:
Precision Custom Homes
Raeferd, NC
Shaun@PrecisionCustomHomesNC.com

DATE:
3/2/23

SCALE:
1/4" = 1'

SHEET:
A-4

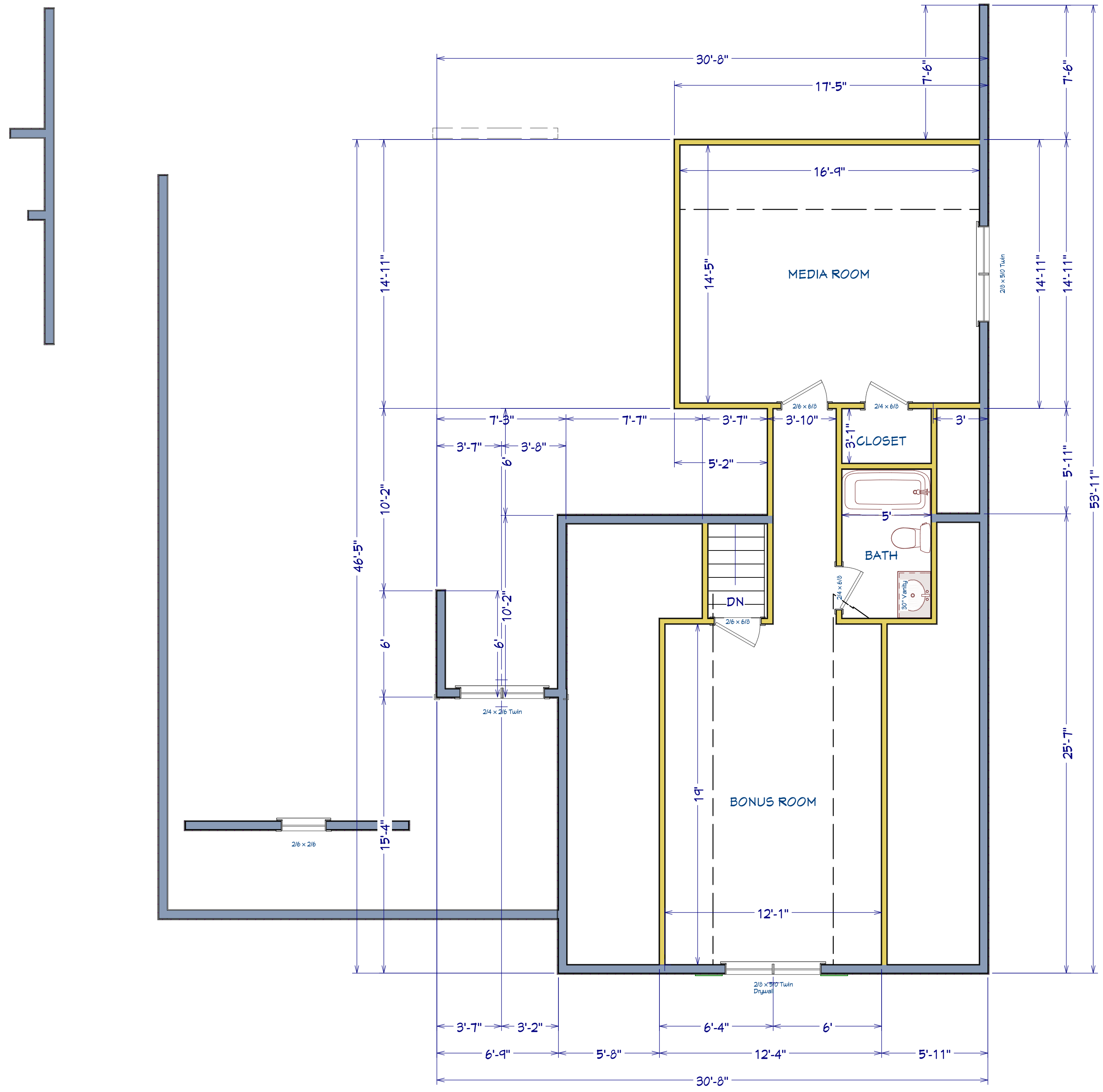

AREA SCHEDULE	
1ST FLOOR AREA	1,785 SF
2ND FLOOR AREA	646 SF
TOTAL HEATED AREA	2,431 SF
<hr/>	
GARAGE	606 SF
FRONT PORCH	156 SF
REAR PORCH	100 SF
TOTAL AREA UNDER ROOF	3,293 SF

PLAN:
Mises

SHEET TITLE:
2nd FLOOR

PROJECT ADDRESS:
126 Sears Dr. (Lot 25)

DESIGNED BY:
Precision Custom Homes
Raeferd, NC
Shaun@PrecisionCustomHomesNC.com

DATE:
3/2/23

SCALE:
1/4" = 1'

SHEET:
A-5