

1. ALL MATERIAL IS 2x4
2. THIS DETAIL IS APPLICABLE FOR DESIGNS WITH DOLS. OF 1.15 OR 1.25 AND LUMBER SPECIES SP, DF, HF, OR SPF.
3. DETAIL SHALL BE USED FOR CONDITIONS OF A MISSING OR LOOSE CONNECTOR PLATE ONLY.
4. CHORD MATERIAL IS CONTINUOUS THROUGH JOINT, THERE IS NO MAXIMUM CHORD FORCE AND NO SPLICE PERMITTED.
5. REFER TO MITEK DESIGN DRAWING FOR WEB FORCES.

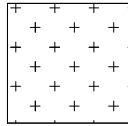

ATTACH 1/2" PLYWOOD OR OSB GUSSET (15/32" RATED SHEATHING 32/16 EXP 1) TO EACH FACE OF TRUSS WITH (0.131" X MIN 2.5") NAILS IN 3 ROWS SPACED @ 4" O.C. NAILS TO BE DRIVEN FROM BOTH FACES. STAGGER SPACING FROM FRONT TO BACK FACE FOR A NET 2" O.C. SPACING IN THE TRUSS. USE 2" MEMBER END DISTANCE.

EDGE OF WEB NOT TO EXTEND BEYOND CORNER OF GUSSET

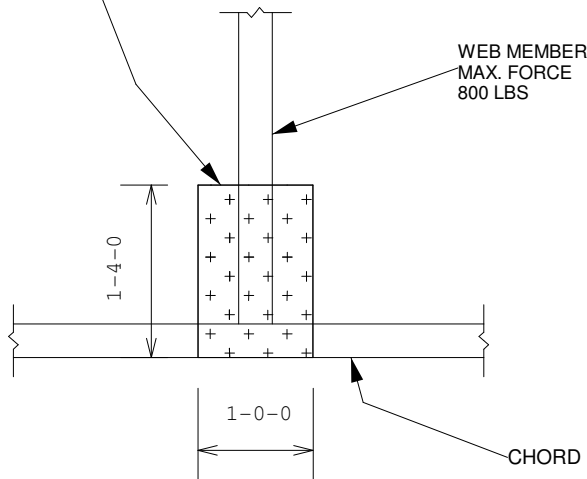

WEB MEMBER MAX. FORCE 1200 LBS

EDGE OF WEB NOT TO EXTEND BEYOND CORNER OF GUSSET

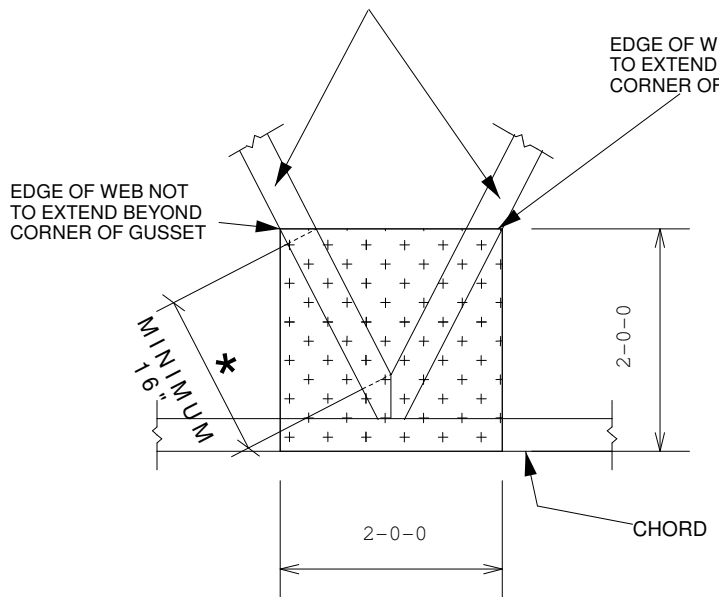

EDGE OF WEB NOT TO EXTEND BEYOND CORNER OF GUSSET

WEB MEMBER MAX. FORCE 1200 LBS

EDGE OF WEB NOT TO EXTEND BEYOND CORNER OF GUSSET

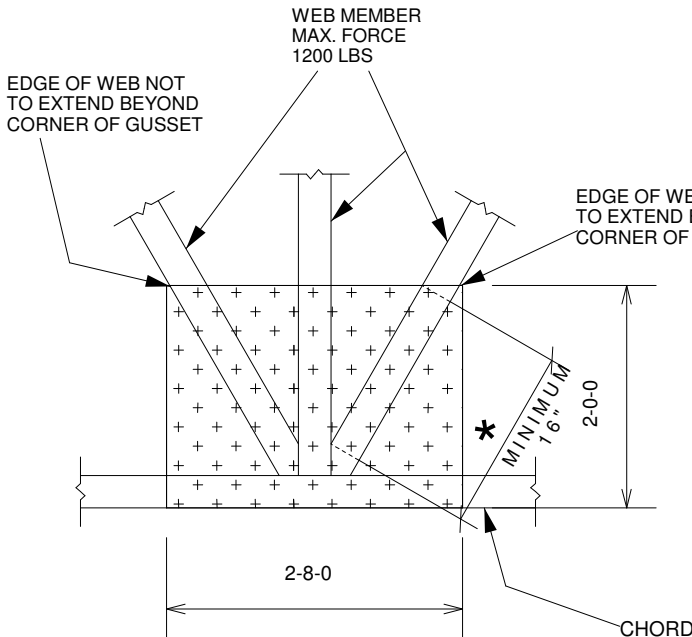

* MEASUREMENT TAKEN AT POINTS WHERE WEB ACHIEVES FULL MEMBER DEPTH (AS MEASURED PERPENDICULAR TO WEB'S SAW-MILLED EDGE)

COL# P-1038

3/21/2022

