

LOT INFORMATION:

PIN: 0652-05-3177.000
 TOTAL LOT AREA = 0.483 AC = 21,032 SF
 HOUSE = 2,330 SF
 PORCH = 130 SF
 SIDEWALK = 34 SF
 DRIVEWAY = 644 SF
 SCREENED PATIO = 200 SF
 PATIO = 100 SF
 STOOP = 9 SF
 AC PAD = 9 SF
 PROPOSED IMPERVIOUS = 3,456 SF
 PERCENT IMPERVIOUS = 16.43 %
 MAXIMUM ALLOWED IMPERVIOUS = 4,000 SF

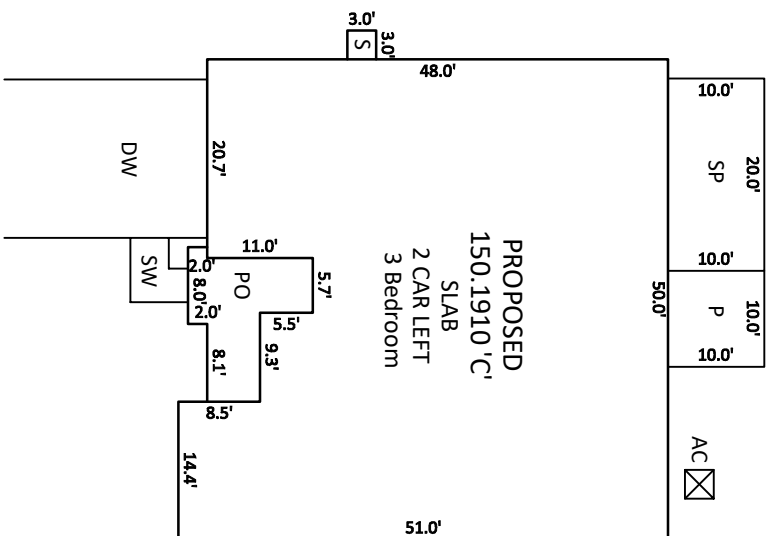

INSET SCALE: 1"=20'

NOTES:

1. THIS SURVEY WAS PREPARED BY BATEMAN CIVIL SURVEY CO., UNDER THE SUPERVISION OF STEVEN P. CARSON, P.L.S.
2. THIS PLAN HAS BEEN PREPARED FOR LAYOUT AND PERMITTING PURPOSES ONLY.
3. PROPERTY LINES SHOWN WERE TAKEN FROM EXISTING FIELD EVIDENCE, EXISTING DEEDS AND/OR PLATS OF PUBLIC RECORD, AND INFORMATION SUPPLIED TO THE SURVEYOR BY THE CLIENT.
4. ALL DISTANCES ARE HORIZONTAL GROUND DISTANCES AND ALL BEARINGS ARE NORTH CAROLINA STATE PLANE COORDINATE SYSTEM UNLESS OTHERWISE SHOWN.
5. THIS MAP IS NOT FOR RECORDATION AND SHOULD BE REVIEWED BY A LOCAL GOVERNMENT AGENCY FOR COMPLIANCE WITH ANY APPLICABLE LAND DEVELOPMENT REGULATIONS.
6. THE BASIS OF NORTH AND ALL EASEMENTS, RIGHTS-OF-WAYS, BUFFERS, SETBACKS AND ADJOINERS, ETC. REFERENCED IN TITLE BLOCK.
7. NO INVESTIGATION INTO THE EXISTENCE OF JURISDICTIONAL WETLANDS OR RIPARIAN BUFFERS PERFORMED BY THIS FIRM.
8. SURVEYOR HAS MADE NO INVESTIGATION OR INDEPENDENT SEARCH FOR EASEMENTS OF RECORD, ENCUMBRANCES, RESTRICTIVE COVENANTS, OWNERSHIP TITLE EVIDENCE OR ANY OTHER FACTS THAT AN ACCURATE AND CURRENT TITLE SEARCH MAY DISCLOSE.
9. THE PROPERTY LIES IN ZONE 'X' PER NATIONAL FLOOD INSURANCE PROGRAM F.I.R.M. MAP #3720064200, DATED OCTOBER 03 2006.
10. ZONING IS - RA-40
11. A 5' PUBLIC UTILITY EASEMENT LIES PARALLEL TO THE ROADWAY RIGHT-OF-WAY ALONG EACH SIDE, EXCEPT OPEN SPACE 4.
12. PROPERTY OWNER: KB HOME RALEIGH- DURHAM INC.
 4506 S. MIAMI BLVD. #100
 DURHAM, NC. 27703

CURVE TABLE			
CURVE	RADIUS	LENGTH	CHORD DIRECTION
C38	285.00'	41.00'	N57°06'26"W

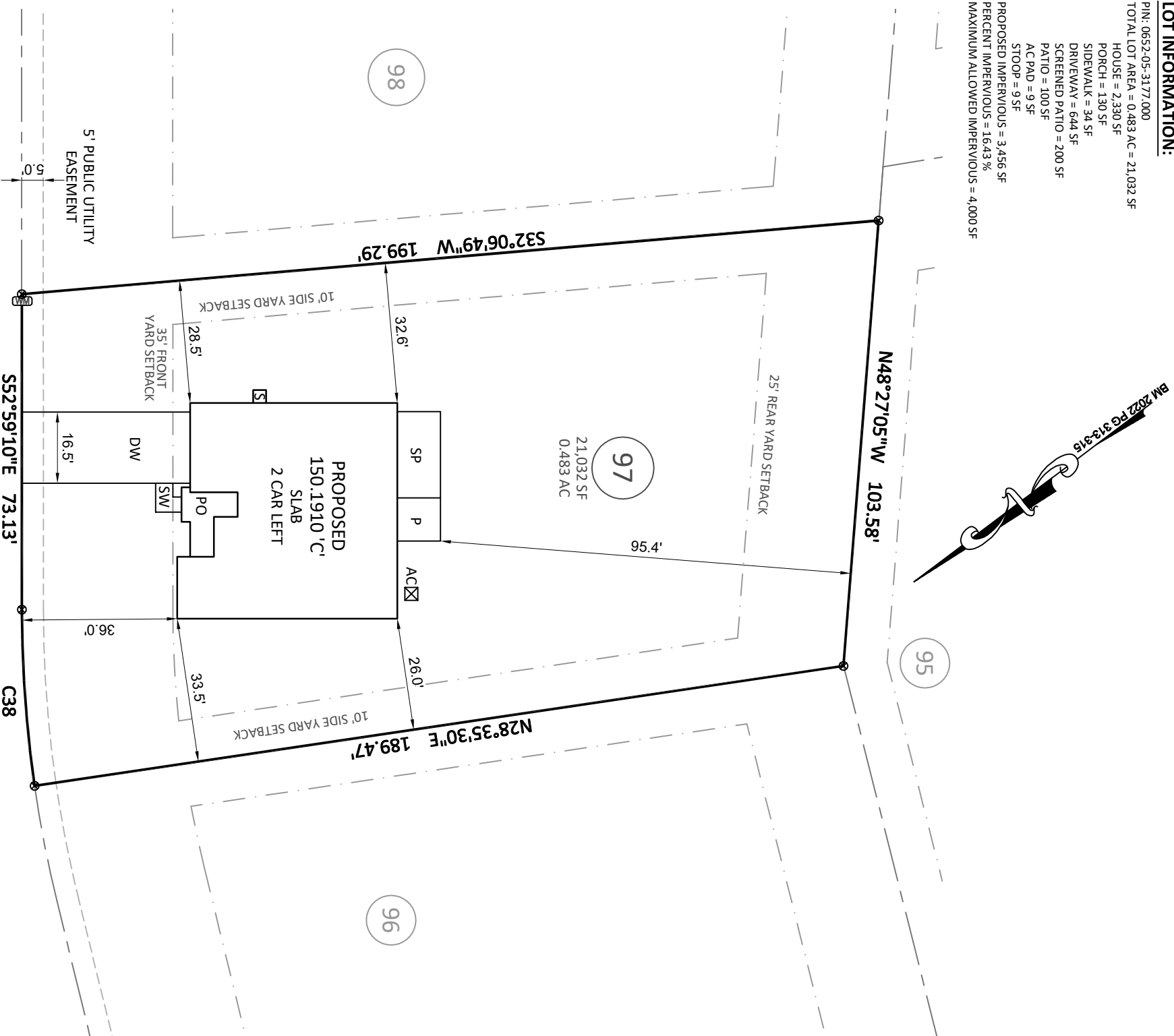

TARLETON DRIVE
 50' PUBLIC RIGHT-OF-WAY & UTILITY

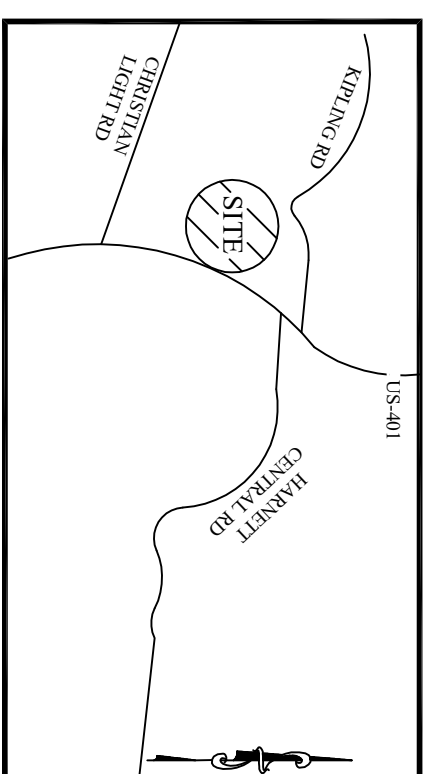
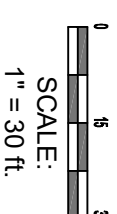

VICINITY MAP

(Not to Scale)

LEGEND
 PO = PORCH
 P = PATIO
 SP = SCREENED PORCH OR PATIO
 CP = COVERED PORCH OR PATIO
 S = STOOP
 SW = SIDEWALK
 DW = CONC DRIVEWAY
 CP = COMPUTED POINT
 IP = IRON PIPE FOUND
 IP(S) = IRON PIPE SET (IPS)
 WM = WATER METER
 CO = CLEANOUT
 AC = AIR CONDITIONER
 EB = ELECTRIC BOX
 CB = CABLE BOX
 TP = TELEPHONE PEDESTAL
 LP = LIGHT POLE
 CI = CURB INLET
 YI = YARD INLET
 FH = FIRE HYDRANT
 HP = HANDICAP PORTAJOHNN WITH SCREENING
 SM = SEWER MANHOLE
 FH = FIRE HYDRANT
 TR = TRASH RECEPTACLES

PRELIMINARY

BUILDING SETBACKS:
 FRONT = 35 ft
 SIDE = 10 ft
 REAR = 25 ft
 CORNER SIDE = 20 ft

This map is of an existing parcel of land and is only intended for the parties and purposes shown. This map not for recordation. No title report provided.

BUILDER TO VERIFY HOUSE LOCATION, DIMENSIONS AND REVIEW TOTAL IMPERVIOUS NOTED ON THIS PLOT PLAN

PRELIMINARY PLOT PLAN

FOR

KB HOMES

BIRCHWOOD GROVE - LOT 97

71 TARLETON DRIVE, FUQUAY-VARINA, NC
 HECTORS CREEK TOWNSHIP, HARNETT COUNTY

DATE: 1/25/23 DRAWN BY: AHB CHECKED BY: SPC

REFERENCE: BM 2022 PG 313-315 PROJECT# 220207 SCALE: 1" = 30'



Bateman Civil Survey Company

Engineers • Surveyors • Planners

2524 Reliance Avenue, Apex, NC 27539 Ph: 919.577.1080 Fax: 919.577.1081
 www.batemancivilsurvey.com info@batemancivilsurvey.com
 NCBELS Firm No. C-2378