

Trenco  
818 Soundside Rd  
Edenton, NC 27932

Re: 23050078-01  
38 Fair Ridge Farm-Roof-Blakely C

The truss drawing(s) referenced below have been prepared by Truss Engineering Co. under my direct supervision based on the parameters provided by Carter Components (Sanford, NC)).

Pages or sheets covered by this seal: I59061154 thru I59061154

My license renewal date for the state of North Carolina is December 31, 2023.

North Carolina COA: C-0844



June 21, 2023

Gilbert, Eric

**IMPORTANT NOTE:** The seal on these truss component designs is a certification that the engineer named is licensed in the jurisdiction(s) identified and that the designs comply with ANSI/TPI 1. These designs are based upon parameters shown (e.g., loads, supports, dimensions, shapes and design codes), which were given to MiTek or TRENCO. Any project specific information included is for MiTek's or TRENCO's customers file reference purpose only, and was not taken into account in the preparation of these designs. MiTek or TRENCO has not independently verified the applicability of the design parameters or the designs for any particular building. Before use, the building designer should verify applicability of design parameters and properly incorporate these designs into the overall building design per ANSI/TPI 1, Chapter 2.

Job 23050078-01	Truss D	Truss Type Piggyback Base	Qty 4	Ply 1	38 Fair Ridge Farm-Roof-Blakely C Job Reference (optional)	159061154
--------------------	------------	------------------------------	----------	----------	---------------------------------------------------------------	-----------

Carter Components (Sanford), Sanford, NC - 27332,

Run: 8.63 S Apr 6 2023 Print: 8.630 S Apr 6 2023 MiTek Industries, Inc. Tue Jun 20 13:21:43  
ID:tzP8SDmGIOMv6LQX6O1dkzeeVr-RfC?PsB70Hq3NSgPqnl8w3uITXbGKWvCDoi7J4zJC?f

Page: 1

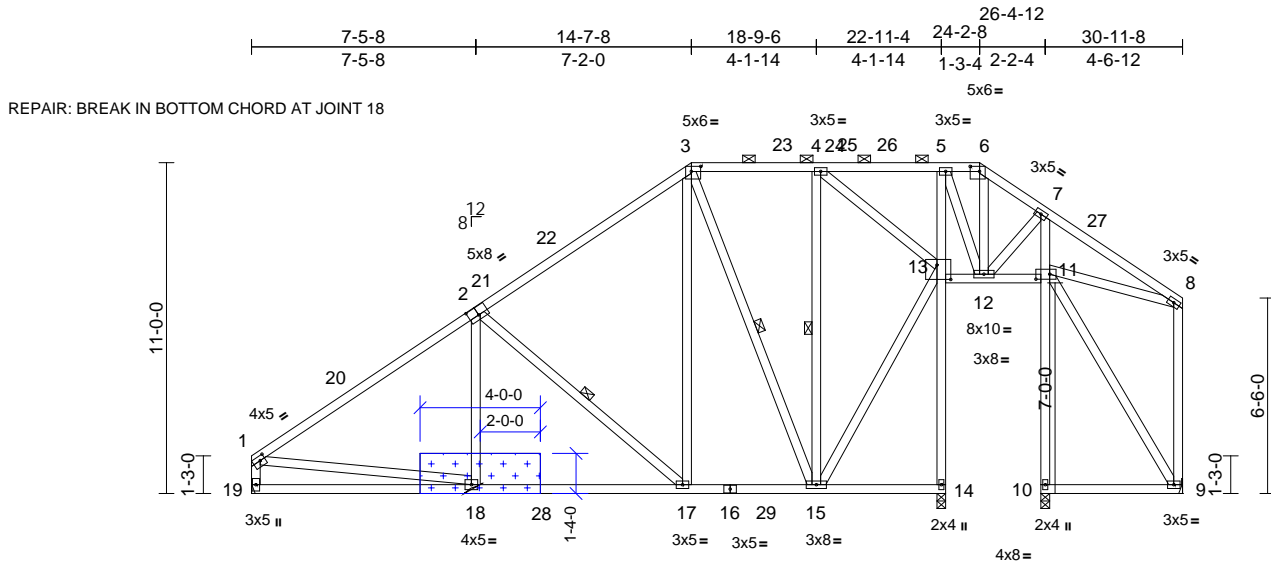

REPAIR: BREAK IN BOTTOM CHORD AT JOINT 18

ATTACH 1/2" PLYWOOD OR OSB GUSSET (15/32" RATED SHEATHING 32/16 EXP 1) TO EACH FACE OF TRUSS WITH (0.131" X 2.5" MIN.) NAILS PER THE FOLLOWING NAIL SCHEDULE:  
2 X 3'S - 2 ROWS, 2 X 4'S - 3 ROWS, 2 X 6'S AND LARGER - 4 ROWS: SPACED @ 4" O.C.  
NAILS TO BE DRIVEN FROM BOTH FACES. STAGGER SPACING FROM FRONT TO BACK FACE FOR A NET 2" O.C. SPACING IN EACH COVERED TRUSS MEMBER. USE 2" MEMBER END DISTANCE.



Scale = 1:76.6

Plate Offsets (X, Y): [1:Edge,0-1-12], [2:0-4-0,0-3-4], [3:0-3-12,0-2-0], [6:0-3-12,0-2-0], [11:0-5-8,0-2-0], [13:0-5-8,0-5-12]
---------------------------------------------------------------------------------------------------------------------------------

Loading	(psf)	Spacing	2-0-0	CSI	DEFL	in	(loc)	l/defl	L/d	PLATES	GRIP	
TCLL (roof)	20.0	Plate Grip DOL	1.15	TC	0.97	Vert(LL)	-0.08	17-18	>999	240	MT20	244/190
Snow (Pf)	20.0	Lumber DOL	1.15	BC	0.62	Vert(CT)	-0.14	18-19	>999	180		
TCDL	10.0	Rep Stress Incr	YES	WB	0.44	Horz(CT)	-0.02	10	n/a	n/a		
BCLL	0.0*	Code	IRC2018/TPI2014	Matrix-MSH								
BCDL	10.0											

Weight: 270 lb FT = 20%

**LUMBER**  
TOP CHORD 2x4 SP No.2  
BOT CHORD 2x4 SP No.2 \*Except\* 7-10:2x4 SP No.3  
WEBS 2x4 SP No.3 \*Except\* 17-3,15-4,15-3:2x4 SP No.2

**BRACING**  
TOP CHORD Structural wood sheathing directly applied, except end verticals, and 2-0-0 oc purlins (6-0-0 max.): 3-6.  
BOT CHORD Rigid ceiling directly applied or 5-5-14 oc bracing.  
WEBS 1 Row at midpt 2-17, 4-15, 3-15

**REACTIONS** (size)  
9= Mechanical, 10=0-3-8, 14=0-3-8, 19= Mechanical  
Max Horiz 19=327 (LC 11)  
Max Uplift 9=-122 (LC 10), 10=-107 (LC 15), 14=-160 (LC 11), 19=-128 (LC 14)  
Max Grav 9=359 (LC 48), 10=484 (LC 44), 14=1210 (LC 5), 19=1075 (LC 46)

**FORCES** (lb) - Maximum Compression/Maximum Tension  
TOP CHORD 1-3=-1304/255, 3-4=-394/273, 4-5=-98/149, 5-6=-93/137, 6-7=-145/152, 7-8=-136/155, 1-19=-961/167, 8-9=-198/90  
BOT CHORD 18-19=-319/389, 17-18=-205/1157, 15-17=-110/596, 14-15=0/3, 13-14=-1147/181, 5-13=-271/106, 12-13=-160/189, 11-12=-203/200, 10-11=-432/139, 7-11=-409/141, 9-10=0/3  
WEBS 2-18=0/279, 2-17=-721/213, 3-17=-69/701, 5-12=-57/85, 6-12=-69/52, 7-12=-18/189, 9-11=-158/178, 8-11=-118/100, 1-18=-31/884, 4-15=-184/260, 3-15=-729/96, 13-15=-162/733, 4-13=-432/158

- Wind: ASCE 7-16; Vult=130mph (3-second gust) Vasd=103mph; TCDL=6.0psf; BCDL=6.0psf; h=25ft; Cat. II; Exp B; Enclosed; MWFRS (envelope) exterior zone and C-C Exterior(2E) 0-1-12 to 3-2-14, Interior (1) 3-2-14 to 10-2-15, Exterior(2R) 10-2-15 to 18-9-6, Interior (1) 18-9-6 to 19-9-15, Exterior(2R) 19-9-15 to 27-8-10, Exterior(2E) 27-8-10 to 30-9-12 zone; cantilever left and right exposed; end vertical left and right exposed; C-C for members and forces & MWFRS for reactions shown; Lumber DOL=1.60 plate grip DOL=1.60
- TCLL: ASCE 7-16; Pr=20.0 psf (roof LL: Lum DOL=1.15 Plate DOL=1.15); Pf=20.0 psf (Lum DOL=1.15 Plate DOL=1.15); Is=1.0; Rough Cat B; Fully Exp.; Ce=0.9; Cs=1.00; Ct=1.10
- Unbalanced snow loads have been considered for this design.
- Provide adequate drainage to prevent water ponding.
- All plates are 3x5 MT20 unless otherwise indicated.
- This truss has been designed for a 10.0 psf bottom chord live load nonconcurrent with any other live loads.
- \* This truss has been designed for a live load of 20.0psf on the bottom chord in all areas where a rectangle 3-06-00 tall by 2-00-00 wide will fit between the bottom chord and any other members, with BCDL = 10.0psf.
- Refer to girder(s) for truss to truss connections.
- Provide mechanical connection (by others) of truss to bearing plate capable of withstanding 128 lb uplift at joint 19 and 122 lb uplift at joint 9.
- One H2.5A Simpson Strong-Tie connectors recommended to connect truss to bearing walls due to UPLIFT at jt(s) 14 and 10. This connection is for uplift only and does not consider lateral forces.
- This truss is designed in accordance with the 2018 International Residential Code sections R502.11.1 and R802.10.2 and referenced standard ANSI/TPI 1.

13) Graphical purlin representation does not depict the size or the orientation of the purlin along the top and/or bottom chord.  
**LOAD CASE(S)** Standard



**NOTES**  
1) Unbalanced roof live loads have been considered for this design.

**WARNING - Verify design parameters and READ NOTES ON THIS AND INCLUDED MITEK REFERENCE PAGE MII-7473 rev. 5/19/2020 BEFORE USE.**  
Design valid for use only with MiTek® connectors. This design is based only upon parameters shown, and is for an individual building component, not a truss system. Before use, the building designer must verify the applicability of design parameters and properly incorporate this design into the overall building design. Bracing indicated is to prevent buckling of individual truss web and/or chord members only. Additional temporary and permanent bracing is always required for stability and to prevent collapse with possible personal injury and property damage. For general guidance regarding the fabrication, storage, delivery, erection and bracing of trusses and truss systems, see **ANSI/TPI1 Quality Criteria, DSB-89 and BCSI Building Component Safety Information** available from Truss Plate Institute, 2670 Crain Highway, Suite 203 Waldorf, MD 20601

**ENGINEERING BY**  
**TRENCO**  
A MiTek Affiliate  
818 Soundside Road  
Edenton, NC 27932

# Symbols

## PLATE LOCATION AND ORIENTATION



Center plate on joint unless x, y offsets are indicated. Dimensions are in ft-in-sixteenths. Apply plates to both sides of truss and fully embed teeth.



For 4 x 2 orientation, locate plates 0- 1/16" from outside edge of truss.



This symbol indicates the required direction of slots in connector plates.

\* Plate location details available in **MITek 20/20 software** or upon request.

## PLATE SIZE

**4 X 4**

The first dimension is the plate width measured perpendicular to slots. Second dimension is the length parallel to slots.

## LATERAL BRACING LOCATION



Indicated by symbol shown and/or by text in the bracing section of the output. Use T or I bracing if indicated.

## BEARING



Indicates location where bearings (supports) occur. Icons vary but reaction section indicates joint number where bearings occur. Min size shown is for crushing only.

### Industry Standards:

ANSI/TP1: National Design Specification for Metal Plate Connected Wood Truss Construction.  
DSB-89: Design Standard for Bracing, Building Component Safety Information, Guide to Good Practice for Handling, Installing & Bracing of Metal Plate Connected Wood Trusses.

# Numbering System

6-4-8  
dimensions shown in ft-in-sixteenths  
(Drawings not to scale)

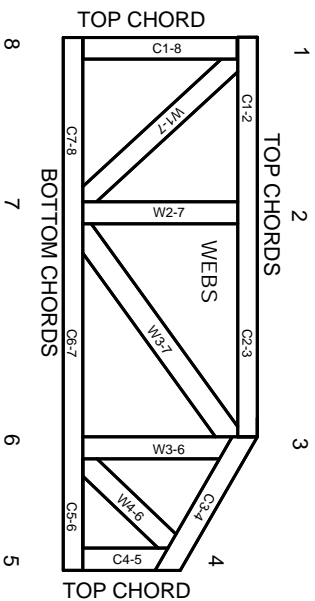

**JOINTS ARE GENERALLY NUMBERED/LETTERED CLOCKWISE AROUND THE TRUSS STARTING AT THE JOINT FARTHEST TO THE LEFT.**

**CHORDS AND WEBS ARE IDENTIFIED BY END JOINT NUMBERS/LETTERS.**

## PRODUCT CODE APPROVALS

ICC-ES Reports:

ESR-1311, ESR-1352, ESR1988  
ER-3907, ESR-2362, ESR-1397, ESR-3282

Trusses are designed for wind loads in the plane of the truss unless otherwise shown.

Lumber design values are in accordance with ANSI/TP1 section 6.3 These truss designs rely on lumber values established by others.

© 2012 MITteK® All Rights Reserved



MITek Engineering Reference Sheet: MII-7473 rev. 5/19/2020



# General Safety Notes

## Failure to Follow Could Cause Property Damage or Personal Injury

1. Additional stability bracing for truss system, e.g. diagonal or X-bracing, is always required. See BCSI.
2. Truss bracing must be designed by an engineer. For wide truss spacing, individual lateral braces themselves may require bracing, or alternative Tor I bracing should be considered.
3. Never exceed the design loading shown and never stack materials on inadequately braced trusses.
4. Provide copies of this truss design to the building designer, erection supervisor, property owner and all other interested parties.
5. Cut members to bear tightly against each other.
6. Place plates on each face of truss at each joint and embed fully. Knots and wane at joint locations are regulated by ANSI/TP1 1.
7. Design assumes trusses will be suitably protected from the environment in accord with ANSI/TP1 1.
8. Unless otherwise noted, moisture content of lumber shall not exceed 19% at time of fabrication.
9. Unless expressly noted, this design is not applicable for use with fire retardant, preservative treated, or green lumber.
10. Camber is a non-structural consideration and is the responsibility of truss fabricator. General practice is to camber for dead load deflection.
11. Plate type, size, orientation and location dimensions indicated are minimum plating requirements.
12. Lumber used shall be of the species and size, and in all respects, equal to or better than that specified.
13. Top chords must be sheathed or purlins provided at spacing indicated on design.
14. Bottom chords require lateral bracing at 10 ft. spacing, or less, if no ceiling is installed, unless otherwise noted.
15. Connections not shown are the responsibility of others.
16. Do not cut or alter truss member or plate without prior approval of an engineer.
17. Install and load vertically unless indicated otherwise.
18. Use of green or treated lumber may pose unacceptable environmental, health or performance risks. Consult with project engineer before use.
19. Review all portions of this design (front, back, words and pictures) before use. Rewriting pictures alone is not sufficient.
20. Design assumes manufacture in accordance with ANSI/TP1 1 Quality Criteria.
21. The design does not take into account any dynamic or other loads other than those expressly stated.