

MiTek USA, Inc.



NOTES:

1. THIS IS A SPECIFIC REPAIR DETAIL TO BE USED ONLY FOR ITS ORIGINAL INTENTION. THIS REPAIR DOES NOT IMPLY THAT THE REMAINING PORTION OF THE TRUSS IS UNDAMAGED. THE ENTIRE TRUSS SHALL BE INSPECTED TO VERIFY THAT NO FURTHER REPAIRS ARE REQUIRED. WHEN THE REQUIRED REPAIRS ARE PROPERLY APPLIED, THE TRUSS WILL BE CAPABLE OF SUPPORTING THE LOADS INDICATED.
2. ALL MEMBERS MUST BE RETURNED TO THEIR ORIGINAL POSITIONS BEFORE APPLYING REPAIR AND HELD IN PLACE DURING APPLICATION OF THE REPAIR.
3. THE END DISTANCE, EDGE DISTANCE, AND SPACING OF NAILS SHALL BE SUCH AS TO AVOID UNUSUAL SPLITTING OF THE WOOD.
4. WHEN NAILING THE PLYWOOD GUSSETS AND/OR SCABS, THE USE OF A BACKUP WEIGHT IS RECOMMENDED TO AVOID LOOSENING OF THE CONNECTOR PLATES AT THE JOINTS OR SPLICES.

New 2x4 or 2x6 member (on edge) of No.2 grade or better added to the top chord. 2x_ members may be ripped to appropriate width to accommodate roof planes(s).

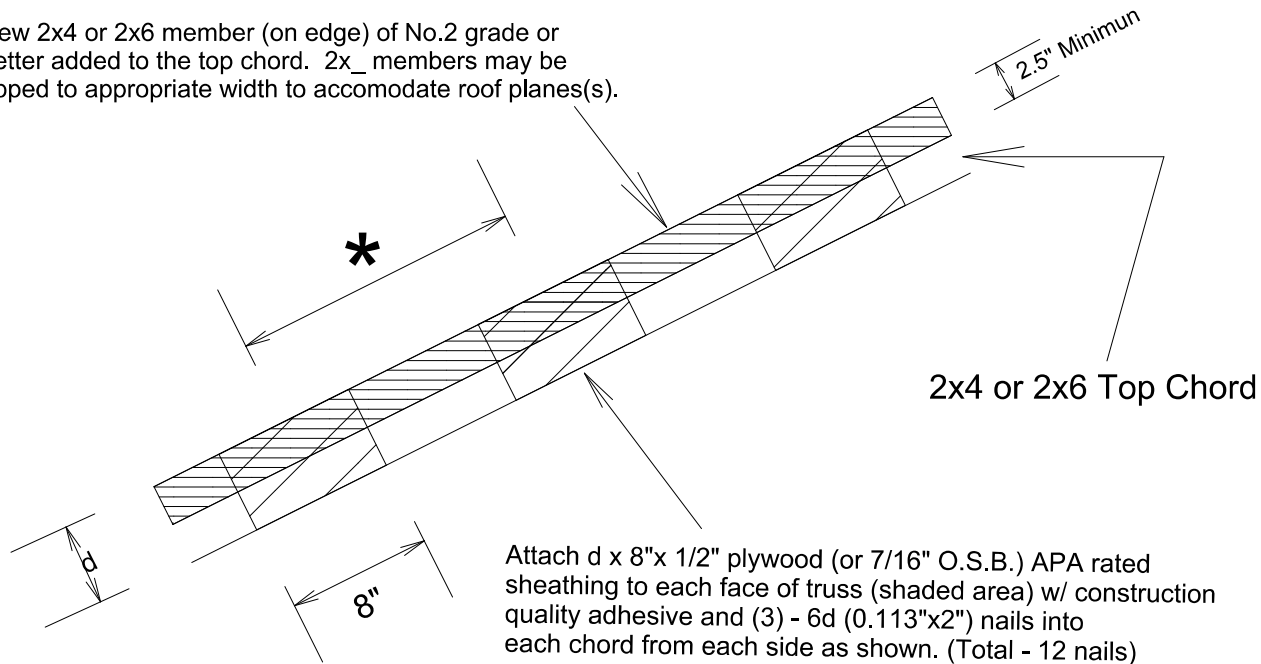

Attach d x 8"x 1/2" plywood (or 7/16" O.S.B.) APA rated sheathing to each face of truss (shaded area) w/ construction quality adhesive and (3) - 6d (0.113"x2") nails into each chord from each side as shown. (Total - 12 nails)

***** Maximum gusset spacing to be the lesser of 36" o.c. or the maximum Top Chord purlin spacing as shown on the individual Engineering Truss Drawings.

IMPORTANT

This repair to be used only with trusses (spans less than 40') spaced 24" o.c. maximum and having pitches between 5/12 and 10/12 and total top chord loads less than 50 psf. Trusses not fitting these criteria should be examined individually.

REFER TO INDIVIDUAL TRUSS DESIGN FOR PLATE SIZES AND LUMBER GRADES

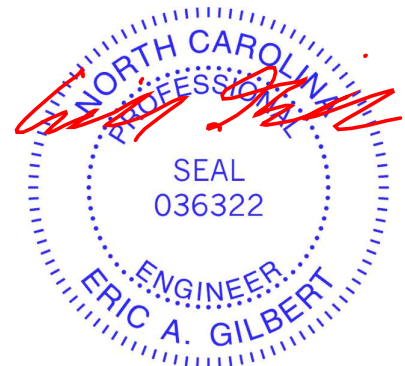

January 25, 2023

WARNING - Verify design parameters and READ NOTES ON THIS AND INCLUDED MITEK REFERENCE PAGE MII-7473 rev. 5/19/2020 BEFORE USE.

Design valid for use only with MiTek® connectors. This design is based only upon parameters shown, and is for an individual building component, not a truss system. Before use, the building designer must verify the applicability of design parameters and properly incorporate this design into the overall building design. Bracing indicated is to prevent buckling of individual truss web and/or chord members only. Additional temporary and permanent bracing is always required for stability and to prevent collapse with possible personal injury and property damage. For general guidance regarding the fabrication, storage, delivery, erection and bracing of trusses and truss systems, see **ANSI/TP1 Quality Criteria, DSB-89 and BCSI Building Component**

Safety Information available from Truss Plate Institute, 2670 Crain Highway, Suite 203 Waldorf, MD 20601



818 Soundside Road
Edenton, NC 27932