

PROVIDE GUTTERS, DOWNSPOUTS AND SPLASHPADS
 ACCORDING TO LOCAL CODE AND RAINFALL CONDITIONS.
 ALL SPLASHPADS SHALL CARRY WATER 60"
 FROM BUILDING.

RIGHT SIDE ELEVATION
 SCALE : 1/4"=1'-0"

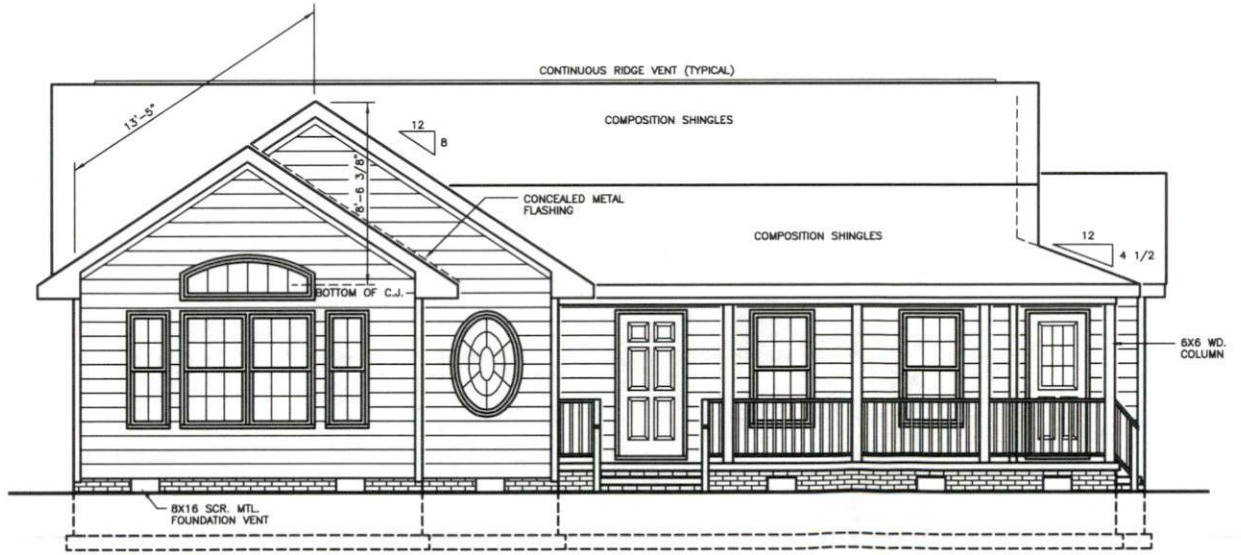

FRONT ELEVATION
 SCALE : 1/4"=1'-0"

REVISED 09-22-22



Standard Homes Plan Service, Inc.
 7200 SUNSET LAKE ROAD FUQUAY-VARINA, NC 27526 (919)552-5677



DESIGNED FOR	PLAN	NO.	MAT'L.	SHOWN	SHEET
	LUTHER	2	SID.		5 OF 8

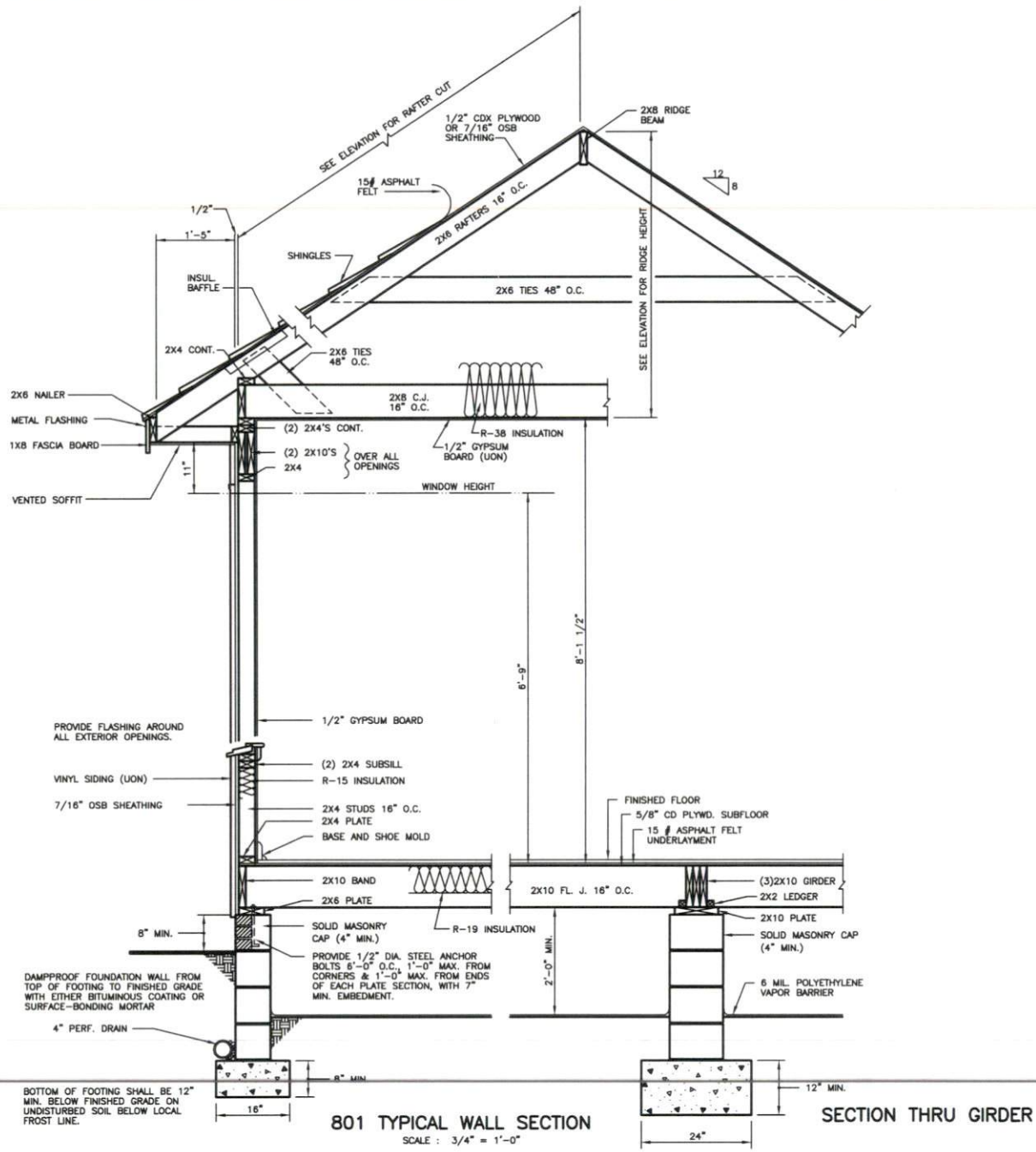

REVISED 09-22-22

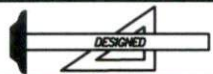

Standard Homes Plan Service, Inc.

7200 SUNSET LAKE ROAD FUQUAY-VARINA, NC 27526 (919)552-5677



DESIGNED FOR	PLAN	NO.	MAT'L. SHOWN	SHEET
	LUTHER	2	SID.	8 OF 8

CONNECTION OF MULTIPLE PLY BEAMS

(INSTALLATION & CONNECTION OF BEAMS SHALL BE ACCORDING TO MANUFACTURERS SPECIFICATIONS)

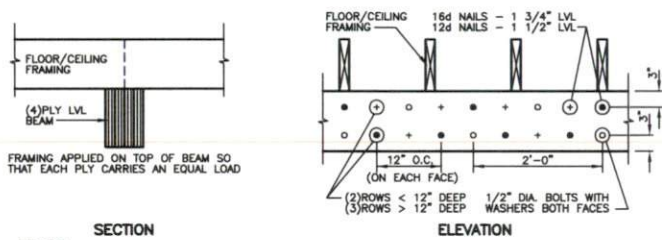

D001
TOP LOADED (4 PILES)

MINIMUM UNIFORMLY DISTRIBUTED LIVE LOADS (PSF)	
USE	LIVE LOAD
UNINHABITABLE ATTICS WITHOUT STORAGE	10
UNINHABITABLE ATTICS WITH LIMITED STORAGE	20
HABITABLE ATTICS AND ATTICS SERVED WITH FIXED STAIRS	30
BALCONIES AND DECKS	40
ROOMS OTHER THAN SLEEPING ROOMS	40
SLEEPING ROOMS	30
STAIRS	40

ALLOWABLE DEFLECTION OF STRUCTURAL MEMBERS (NOTE : L = SPAN LENGTH)	
STRUCTURAL MEMBER	ALLOWABLE DEFLECTION
RAFTERS HAVING SLOPES GREATER THAN 3:12 WITH FINISHED CEILING NOT ATTACHED TO RAFTERS	L/180
FLOORS	L/360
CEILING WITH BRITTLE FINISHES (INCLUDING PLASTER AND STUCCO)	L/360
CEILING WITH FLEXIBLE FINISHES (INCLUDING GYPSUM BOARD)	L/240
ALL OTHER STRUCTURAL MEMBERS	L/240
LINTELS SUPPORTING MASONRY VENEER WALLS	L/600

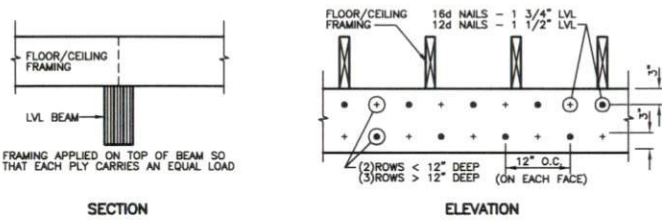

D002
TOP LOADED (3 PILES MAXIMUM)

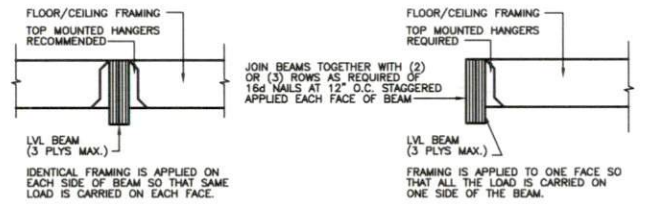

D003
SIDE LOADED

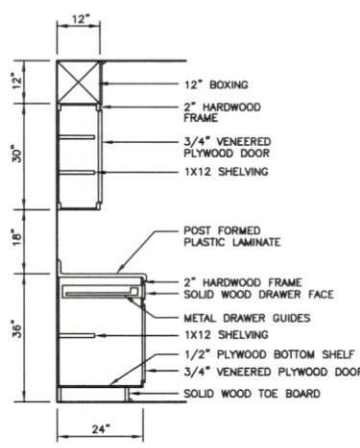

D005
SECTION THRU KITCHEN CABINETS

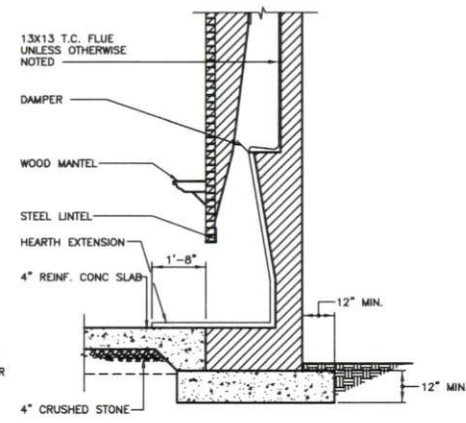

D006
SECT. THRU FIREPLACE ON CONCRETE SLAB

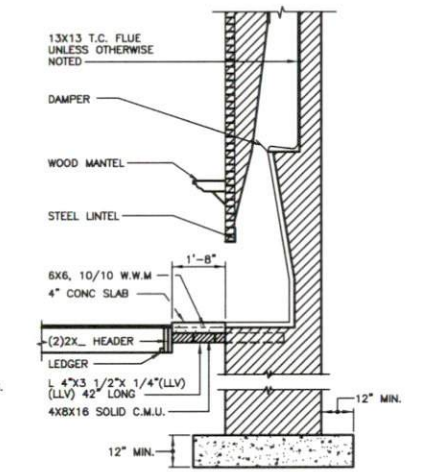

D007
SECT. THRU FIREPLACE ON WOOD FLOOR

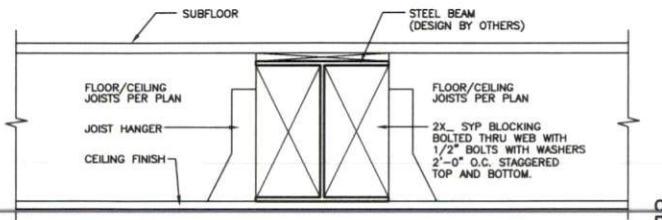

D004
SECTION THRU STEEL BEAM

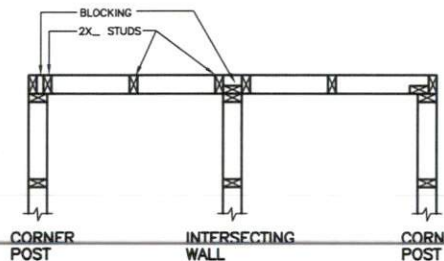

D007
DETAIL BASIC WALL FRAMING

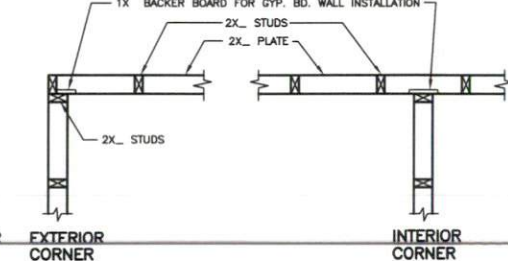

D008
DETAIL ADVANCED WALL FRAMING

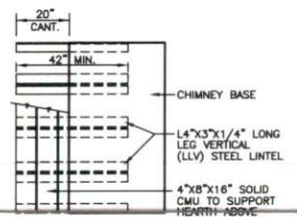

D006
PLAN VIEW OF SUSPENDED HEARTH



Standard Homes Plan Service, Inc.
7200 SUNSET LAKE ROAD FUQUAY-VARINA, NC 27526 (919)552-5677
SEE HOME DESIGN PREVIEWS ONLINE AT WWW.STANDARDHOMES.COM



STANDARD CONSTRUCTION DETAILS

D

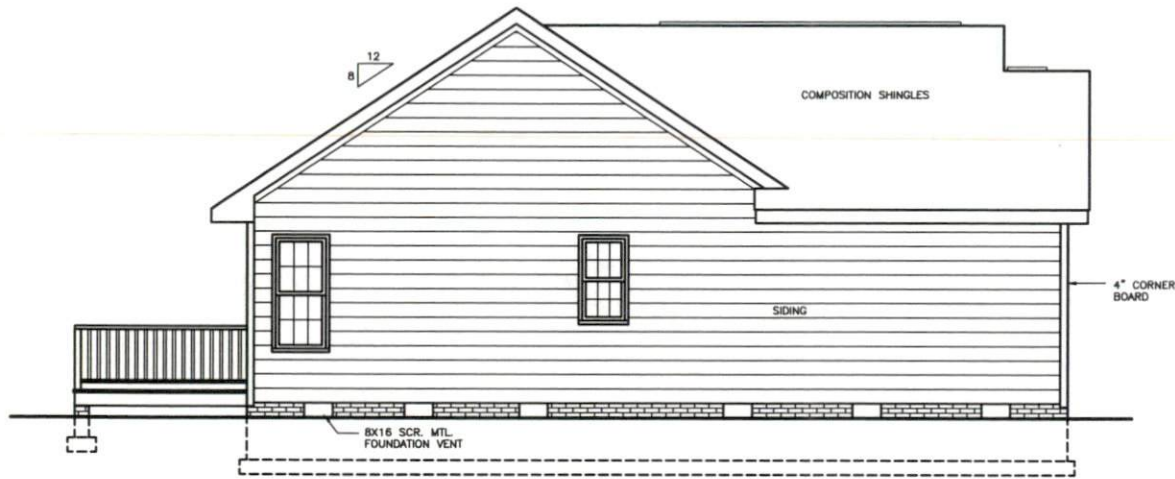

LEFT SIDE ELEVATION
SCALE : 1/4"=1'-0"



REAR ELEVATION
SCALE : 1/4"=1'-0"

REVISED 09-22-22



Standard Homes Plan Service, Inc.

7200 SUNSET LAKE ROAD FUQUAY-VARINA, NC 27526 (919)552-5677



DESIGNED FOR	PLAN	NO.	MAT'L	SHOWN	SHEET
	LUTHER	2	SID.		6 OF 8

© 2004 STANDARD HOMES PLAN SERVICE, INC.