

**ABBREVIATIONS**

- ACC. = ACCESS
- BWL = BRACED WALL LINE
- BWP. = BRACED WALL PANEL
- C.O. = CASED OPENING
- C.J. = CEILING JOIST
- CLOSET = CLOSET
- COL. = COLUMN
- COMP. = COMPOSITION
- CONC. = CONCRETE
- CONT. = CONTINUOUS
- C.M.A. = CARBON MONOXIDE ALARM
- C.M.U. = CONCRETE MASONRY UNIT
- D.H. = DOUBLE HUNG
- DIA. = DIAMETER
- D.J. = DOUBLE JOIST
- DN. = DOWN
- EXH. = EXHAUST
- EXT. = EXTERIOR
- FL.J. = FLOOR JOIST
- FTG. = FOOTING
- G.F.I. = GROUND FAULT INTERRUPTER
- H.B. = HOSE BIB
- LVL. = LAMINATED VENEER LUMBER
- M.O. = MASONRY OPENING
- MAS. = MASONRY
- MAX. = MAXIMUM
- M.C. = MEDICINE CABINET
- MTL. = METAL
- MIN. = MINIMUM
- O.C. = ON CENTER
- OSB = ORIENTED STRAND BOARD
- PERF. = PERFORATED
- REC. = RECESSED
- REINF. = REINFORCED
- SCR. = SCREENED
- S.D. = SMOKE DETECTOR
- SEC. = SECOND
- SHWR. = SHOWER
- S.Y.P. = SOUTHERN YELLOW PINE
- S.P.F. = SPRUCE/PINE/FIR
- SUSP. = SUSPENDED
- TYP. = TYPICAL
- U.O.N. = UNLESS OTHERWISE NOTED
- WASH. = WASHER
- W.H. = WATER HEATER
- W.P. = WEATHER PROOF
- W.W.M. = WELDED WIRE MESH
- WDW. HT. = WINDOW HEIGHT
- WD. = WOOD

**SYMBOLS**

- O- = HOSE BIB
- S = SWITCH
- S<sub>3</sub> = 3-WAY SWITCH
- ◇ = LIGHT FIXTURE
- ⊞ = EXHAUST FAN & LIGHT
- ☐ = SMOKE DETECTOR
- ◁ = SHOWER HEAD
- ⚡ = TELEPHONE JACK
- ⊕ = CONVENIENCE OUTLET
- ⊗ = 220 VOLT OUTLET
- ⦿ = GROUND FAULT INTERRUPTER
- ⊗ = CEILING FAN
- Ⓢ = CARBON MONOXIDE ALARM

**GENERAL NOTES AND SPECIFICATIONS**

**COPYRIGHT**

THIS PLAN IS PROTECTED UNDER THE FEDERAL COPYRIGHT ACT. REPRODUCTION IN WHOLE OR IN PART, INCLUDING DIRECT COPYING AND/OR PREPARATION OF DERIVATIVE WORKS, FOR ANY REASON WITHOUT THE PRIOR WRITTEN CONSENT FROM STANDARD HOMES PLAN SERVICE, INC. IS STRICTLY PROHIBITED.

**ORIGINAL PURCHASE AGREEMENT**

SEE ATTACHED CONSTRUCTION LICENSE FOR INVOICE NUMBER 13094.

**BUILDING CODE INFORMATION**

THIS PLAN HAS BEEN DRAWN TO CONFORM TO THE NORTH CAROLINA RESIDENTIAL CODE, 2018 EDITION (2015 INTERNATIONAL RESIDENTIAL CODE FOR ONE- AND TWO-FAMILY DWELLINGS, CURRENT EDITION) WITH AMENDMENTS UNLESS OTHERWISE NOTED. (SEE ATTACHMENTS)

**PRIOR TO CONSTRUCTION**

THE CONTRACTOR SHALL REVIEW THE PLAN(S) FOR THIS PARTICULAR BUILDING PROJECT TO ENSURE COMPLIANCE WITH ALL NATIONAL, STATE AND LOCAL CODES, CLIMATIC GEOGRAPHIC DESIGN CRITERIA, AND ANY OTHER PROVISIONS THAT MAY BE REQUIRED BY VA/FVA/RD.

THE CONTRACTOR SHALL VERIFY PLAN DIMENSIONS, STRUCTURAL COMPONENTS, AND GENERAL SPECIFICATIONS CONTAINED IN THIS SET OF PLANS AND REPORT ANY DISCREPANCIES TO STANDARD HOMES PLAN SERVICE, INC. FOR JUSTIFICATION OR CORRECTION BEFORE PROCEEDING WITH WORK ON HOUSE.

THE CONTRACTOR SHALL DETERMINE ROUGH OPENING SIZES FOR ALL BUILT-IN EQUIPMENT AND/OR FACILITIES AND ADJUST PLAN DIMENSIONS AS REQUIRED.

DO NOT SCALE FROM BLUEPRINTS. REFER TO THE LABELED DIMENSIONS FOR ACTUAL MEASUREMENTS.

IT SHALL BE THE RESPONSIBILITY OF THE OWNER/BUILDER TO PROVIDE FOR THE SERVICES OF A PROFESSIONAL ENGINEER IF REQUIRED BY THE BUILDING CODE OFFICIAL.

**SHIPPING DATE : \_\_\_\_\_**

STAMP MUST APPEAR IN RED. PLANS FOR WHICH A BUILDING PERMIT HAS NOT BEEN OBTAINED ONE YEAR FROM THE ABOVE DATE IS SUBJECT TO REVIEW BY STANDARD HOMES PLAN SERVICE, INC. A FEE MAY BE CHARGED FOR THIS SERVICE.

**EXCAVATION**

EXCAVATE TO UNDISTURBED SOIL. BOTTOM OF FOOTING SHALL EXTEND BELOW LOCAL FROST LINE AND TO A MINIMUM DEPTH OF 12" BELOW ADJACENT GRADE. (PRESUMED 2000 PSF SOIL BEARING CAPACITY).

EXPANSIVE, COMPRESSIVE OR SHIFTING SOILS SHALL BE MOVED TO A DEPTH AND WIDTH SUFFICIENT TO ASSUME A STABLE MOISTURE CONTENT IN EACH ACTIVE ZONE.

**FOUNDATION**

PROVIDE 1/2" DIA. STEEL ANCHOR BOLTS 6"-0" O.C., 1'-0" MAX. FROM CORNERS AND 1'-0" MAX. FROM ENDS OF EACH PLATE SECTION, WITH 7" MIN. EMBEDMENT.

PROVIDE FOUNDATION WATERPROOFING AND DRAIN WITH POSITIVE SLOPE TO OUTLET AS REQUIRED BY SITE CONDITIONS.

SLOPE GRADE AWAY FROM FOUNDATION WALLS 6" MINIMUM WITHIN THE FIRST 10 FEET.

PROVIDE PRESSURE TREATED LUMBER FOR SILLS, PLATES, BANDS AND ANY LUMBER IN CONTACT WITH MASONRY.

PROVIDE APPROVED AND BONDED CHEMICAL SOIL TREATMENT AGAINST FUNGUS, TERMITES AND OTHER HARMFUL INSECTS.

**CRAWL SPACE**

ALL GIRDER JOINTS AND ENDS OF GIRDERS SHALL REST ON SOLID BEARINGS. FILL CORES OF HOLLOW MASONRY TO FOOTING WITH CONCRETE. FILL TOP COURSE CORES OF EXTERIOR FOUNDATION WALL WITH CONCRETE.

FOOTINGS SHALL EXTEND 6" AND SHALL BE 12" THICK UNDER GIRDER PIERS.

CHIMNEY FOOTING SHALL EXTEND 12" MINIMUM BEYOND EACH SIDE AND SHALL BE AT LEAST 12" THICK.

**BASEMENT**

ALL GIRDER JOINTS SHALL BREAK ON COLUMN CENTER LINES (STAGGERED) AND ENDS OF GIRDERS SHALL REST ON SOLID MASONRY.

DOUBLE SILL AND USE LEDGER OVER ALL BASEMENT OPENINGS.

ALL BASE, SASH SHALL BE 18/20 2-LT. 3'-3 7/8" X 1'-11 15/16" 3420 HB.

**FRAMING**

ALL FLOOR JOISTS, CEILING JOISTS, RAFTERS, GIRDERS, HEADERS, SILLS AND BEAMS SHALL BE NO. 2 SPRUCE/PINE/FIR (S.P.F.) UNLESS OTHERWISE INDICATED.

ALL LOAD BEARING WALLS SHALL BE STUD GRADE SPRUCE/PINE/FIR (S.P.F.) UNLESS OTHERWISE INDICATED.

DESIGN SPECIFICATIONS FOR LAMINATED VENEER LUMBER (LVL) BEAMS AND HEADERS :

- GRADE : 2950Fb-2.0E
- BENDING Fb : 2950
- MOE : 2.0 X 10<sup>6</sup>
- SHEAR Fv : 290

**SUPPORT FOR HEADERS:**

HEADERS SHALL BE SUPPORTED ON EACH END WITH ONE OR MORE JACK STUDS OR WITH APPROVED FRAMING ANCHORS IN ACCORDANCE WITH BUILDING CODE (SEE PLAN). THE FULL-HEIGHT STUD ADJACENT TO EACH END OF THE HEADER SHALL BE END NAILED TO EACH END OF THE HEADER WITH FOUR-16D NAILS. SEE TABLE BELOW.

MINIMUM NUMBER OF FULL HEIGHT STUDS AT EACH END OF HEADERS IN EXTERIOR WALLS:

HEADER SPAN (FEET)	MAXIMUM STUD SPACING (INCHES)	
	16	24
3 FEET OR LESS	1	1
4 FT.	2	1
8 FT.	3	2
12 FT.	5	3
16 FT.	8	4

**CLIMATIC AND GEOGRAPHICAL DESIGN CRITERIA**

ROOF LIVE LOAD (POUNDS PER SQUARE FOOT) : 20 PSF  
 ULTIMATE DESIGN WIND SPEED (MILES PER HOUR) : 120 MPH  
 NOMINAL DESIGN WIND SPEED : 93 MPH  
 EXPOSURE CATEGORY "B" UNLESS OTHERWISE NOTED  
 WINDOW DESIGN PRESSURE RATING : DP 25  
 COMPONENT AND CLADDING LOADS FOR A BUILDING WITH A MEAN ROOF HEIGHT OF 30 FEET OR LESS:

PRESSURE ZONE	ULTIMATE DESIGN WIND SPEED (MPH)			
	115	120	130	140
ZONE 1	13.1, -14.0	14.2, -15.0	16.7, -18.0	19.4, -21.0
ZONE 2	13.1, -16.0	14.2, -18.0	16.7, -21.0	19.4, -24.0
ZONE 3	13.1, -18.0	14.2, -18.0	16.7, -21.0	19.4, -24.0
ZONE 4	14.3, -15.0	15.5, -16.0	18.2, -19.0	21.2, -22.0
ZONE 5	14.3, -19.0	15.5, -20.0	18.2, -24.0	21.2, -28.0

ASSUMED MEAN ROOF HEIGHT: 16'-2"

SEISMIC CONDITION BY ZONE : ZONES A AND B

SUBJECT TO DAMAGE FROM WEATHERING : MODERATE

CLIMATE ZONES (UNLESS OTHERWISE NOTED): ZONES 3 AND 4

MINIMUM VALUES FOR ENERGY COMPLIANCE:  
 CEILING R-38; EXTERIOR WALLS R-15; FLOORS R-19  
 WINDOW U-FACTOR ≤ 0.35; RECOMMENDED SHGC ≤ 0.30

**MISCELLANEOUS**

LOCATE ALL CONVENIENCE OUTLETS ABOVE KITCHEN BASE CABINETS 42" ABOVE FINISHED FLOOR.

**EMERGENCY EGRESS REQUIREMENTS**

IT SHALL BE THE RESPONSIBILITY OF THE OWNER/BUILDER TO VERIFY CONFORMITY WITH EGRESS REQUIREMENTS BASED ON SPECIFICATIONS PROVIDED BY WINDOW MANUFACTURER.

2018 NORTH CAROLINA RESIDENTIAL CODE

THE REQUIRED EGRESS WINDOW FROM EVERY SLEEPING ROOM SHALL HAVE A SILL HEIGHT OF NOT MORE THAN 44 INCHES ABOVE FINISHED FLOOR. THE NET CLEAR OPENING SHALL NOT BE LESS THAN 4.0 SQUARE FEET WHERE THE NET CLEAR OPENING HEIGHT SHALL BE AT LEAST 22 INCHES AND THE NET CLEAR OPENING WIDTH SHALL BE AT LEAST 20 INCHES. IN ADDITION THE MINIMUM TOTAL GLASS AREA SHALL NOT BE LESS THAN 5.0 SQUARE FEET IN THE CASE OF A GROUND STORY WINDOW AND NOT LESS THAN 5.7 SQUARE FEET IN THE CASE OF A SECOND STORY WINDOW.

2015 INTERNATIONAL RESIDENTIAL CODE

THE REQUIRED EGRESS WINDOW FROM EVERY SLEEPING ROOM SHALL HAVE A SILL HEIGHT OF NOT MORE THAN 44 INCHES ABOVE FINISHED FLOOR. ALL EMERGENCY ESCAPE AND RESCUE OPENINGS SHALL HAVE A MINIMUM NET CLEAR OPENING OF 5.7 SQUARE FEET EXCEPT GRADE FLOOR OPENINGS SHALL HAVE A MINIMUM NET OPENING OF 5 SQUARE FEET. THE MINIMUM NET CLEAR OPENING HEIGHT SHALL BE 24 INCHES. THE MINIMUM NET CLEAR OPENING WIDTH SHALL BE 20 INCHES.

REVISED 09-22-22



**Standard Homes Plan Service, Inc.**

7200 SUNSET LAKE ROAD FUQUAY-VARINA, NC 27526 (919)552-5677

SEE HOME DESIGN PREVIEWS ONLINE AT WWW.STANDARDHOMES.COM



DESIGNED FOR	PLAN	NO.	MAT'L.	SHOWN	SHEET
	LUTHER	2	SID.		1 OF 8



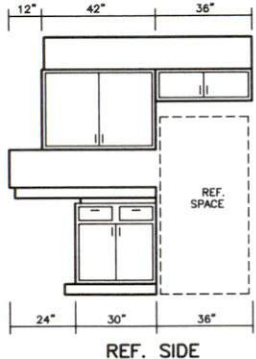

**KITCHEN CABINET ELEVATIONS**  
 SCALE : 3/8"=1'-0"  
 FOR SECTION THRU CABINETS, SEE DETAIL ON COVER SHEET.  
 PROVIDE 2" MINIMUM AIRSPACE BETWEEN FLUE AND ALL COMBUSTIBLE MATERIALS.  
 PROVIDE APPROVED SMOKE DETECTOR(S) AS REQUIRED BY LOCAL CODE.

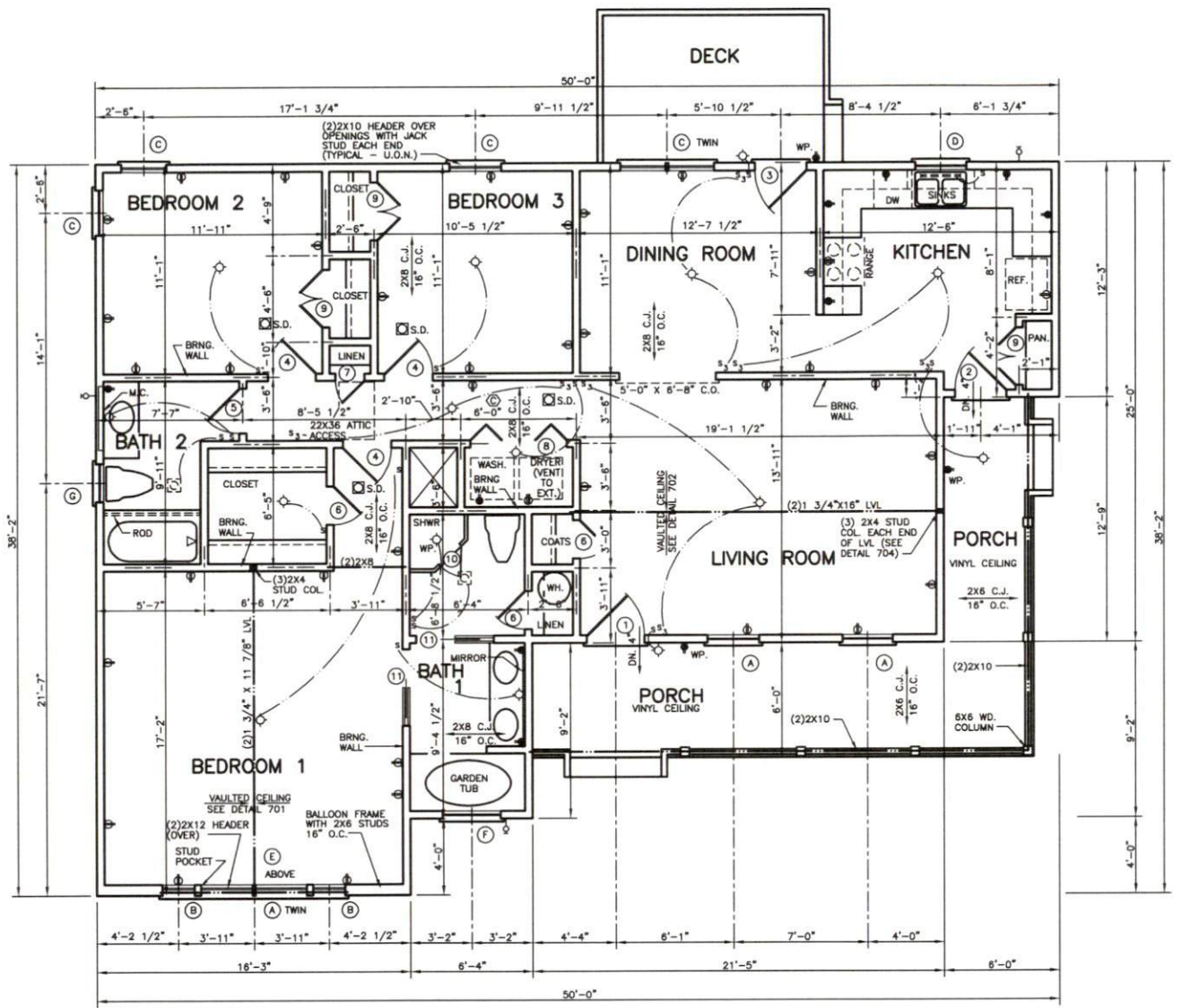
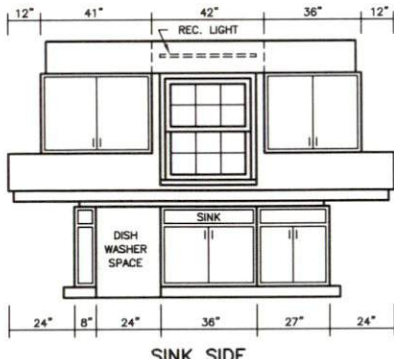
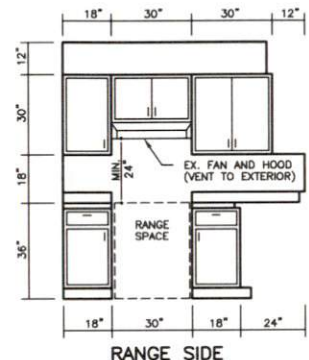

HEATED AREA : 1445 SQ. FT. IN SIDING  
 DECK & PORCH : 312 SQ. FT.

**FLOOR PLAN**  
 SCALE : 1/4" = 1'-0"

REVISED 09-22-22

**WINDOW SCHEDULE**

A	2'-8" X 5'-2" WD. D.H.	D	2'-8" X 3'-2" WD. D.H.	G	2'-0" X 3'-10" WD. D.H.	L	
B	1'-8" X 5'-2" WD. D.H.	E	ANDERSEN AFFW601 5'-11 1/4" X 1'-9 7/16"	H		M	
C	2'-4" X 5'-2" WD. D.H.	F	ANDERSEN OVL3048 3'-0" X 4'-8 1/2"	K		N	

**DOOR SCHEDULE**

1	3'-0" X 6'-8" X 1 3/4"	4	2'-6" X 6'-8" X 1 3/8"	7	1'-6" X 6'-8" X 1 3/8"	10	TEMP. GLASS SHOWER ENCLOSURE
2	2'-8" X 6'-8" X 1 3/4"	5	2'-4" X 6'-8" X 1 3/8"	8	5'-0" X 6'-8" X 1 3/8"	11	POCKET DOOR
3	2'-8" X 6'-8" X 1 3/4"	6	2'-0" X 6'-8" X 1 3/8"	9	DOUBLE OPENING 3'-0" X 6'-8" X 1 3/8"	12	LOUVERED BIFOLD

**Standard Homes Plan Service, Inc.**  
 7200 SUNSET LAKE ROAD FLOQUAY-VARINA, N.C. 27526 (919)552-5677

DESIGNED FOR	LUTHER		NO.	2	MATERIAL	SID.
PLAN						
						SHEET 3 of 8

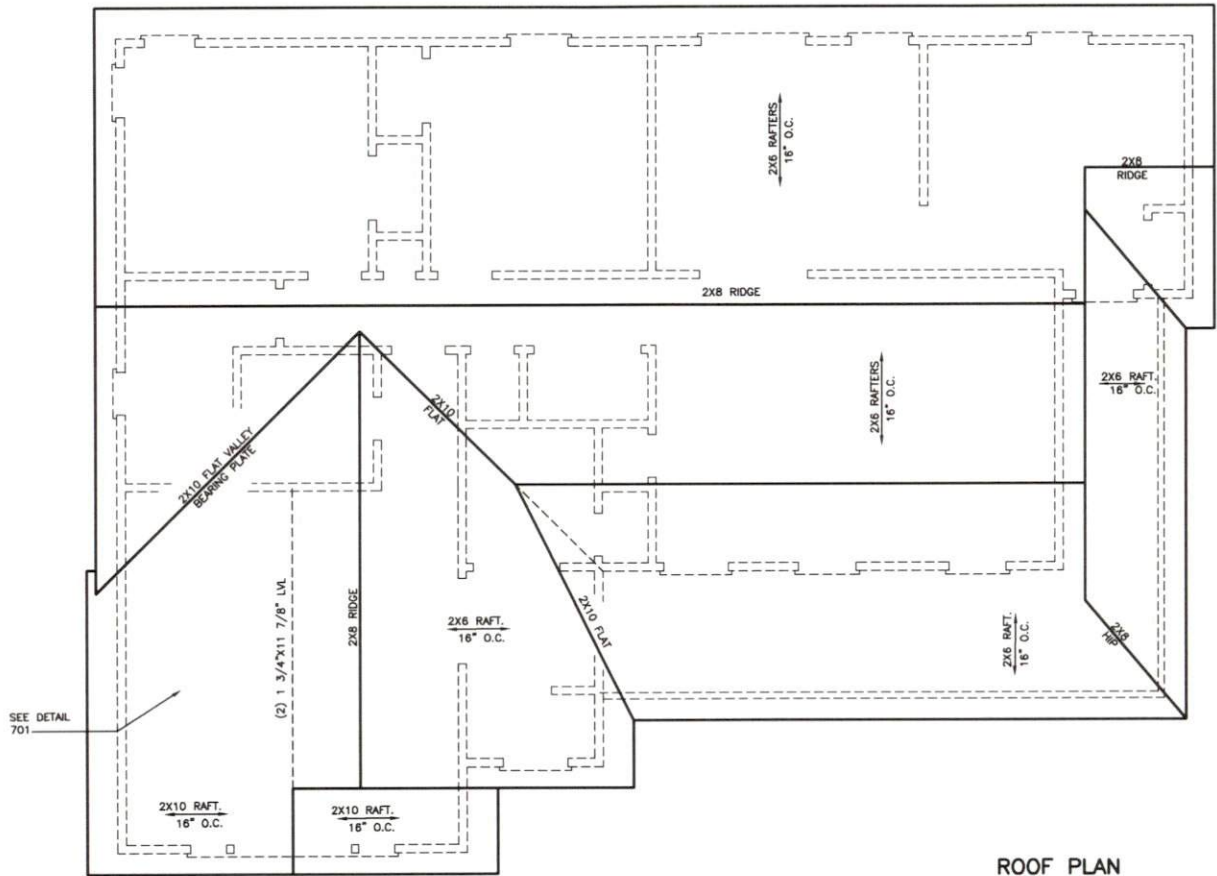

ATTIC VENTILATION REQUIREMENTS :  
 1661 SQ. FT. → 150 = 11.07 SQ. FT. NET  
 FREE AREA REQUIRED

ROOF PLAN  
 SCALE : 1/4"=1'-0"

REVISED 09-22-22



**Standard Homes Plan Service, Inc.**

7200 SUNSET LAKE ROAD FUQUAY-VARINA, NC 27526 (919)552-5677

SEE HOME DESIGN PREVIEWS ONLINE AT WWW.STANDARHHOMES.COM



DESIGNED FOR	PLAN	NO.	MAT'L.	SHOWN	SHEET
	LUTHER	2	SID.		4 of 8

© 2004 STANDARD HOMES PLAN SERVICE, INC.

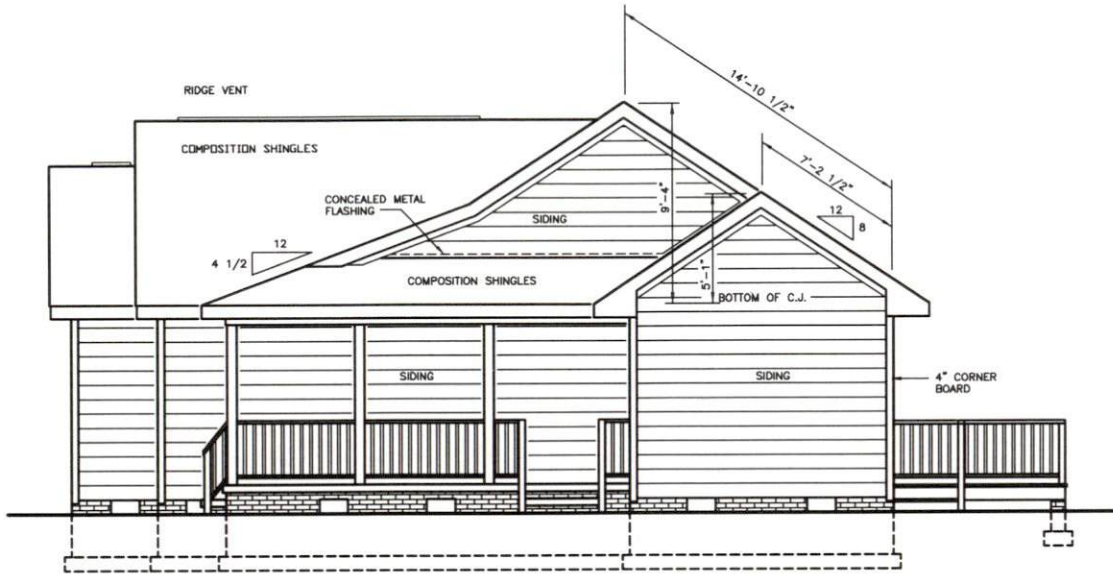

PROVIDE GUTTERS, DOWNSPOUTS AND SPLASHPADS  
 ACCORDING TO LOCAL CODE AND RAINFALL CONDITIONS.  
 ALL SPLASHPADS SHALL CARRY WATER 60"  
 FROM BUILDING.

RIGHT SIDE ELEVATION  
 SCALE : 1/4"=1'-0"

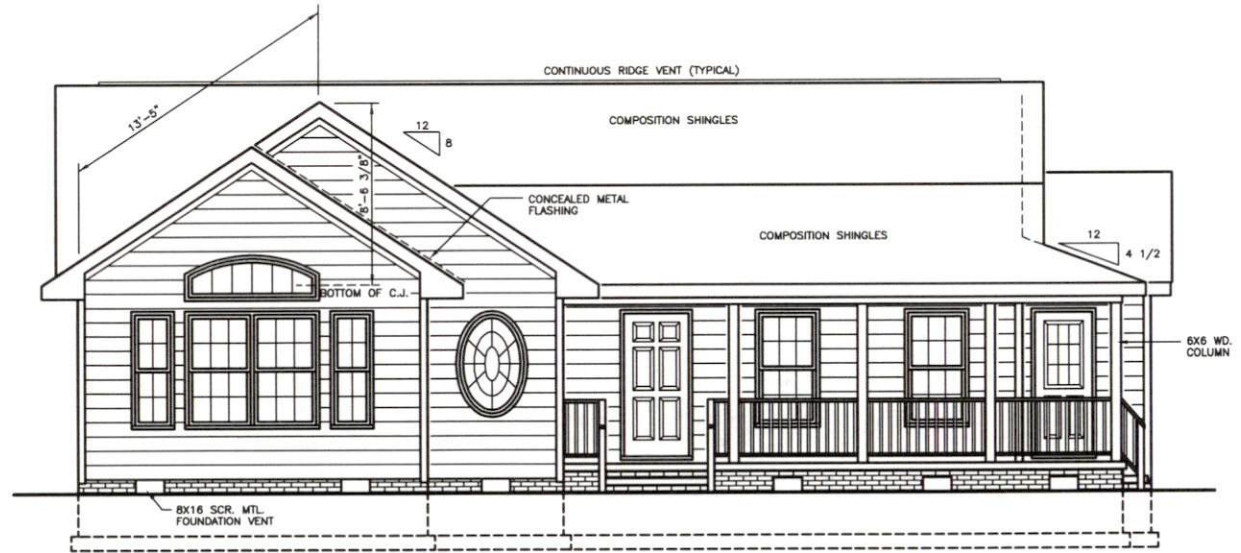

FRONT ELEVATION  
 SCALE : 1/4"=1'-0"

REVISED 09-22-22



**Standard Homes Plan Service, Inc.**

7200 SUNSET LAKE ROAD FUQUAY-VARINA, NC 27526 (919)552-5677



DESIGNED FOR	PLAN	NO.	MAT'L.	SHOWN	SHEET
	LUTHER	2	SID.		5 OF 8

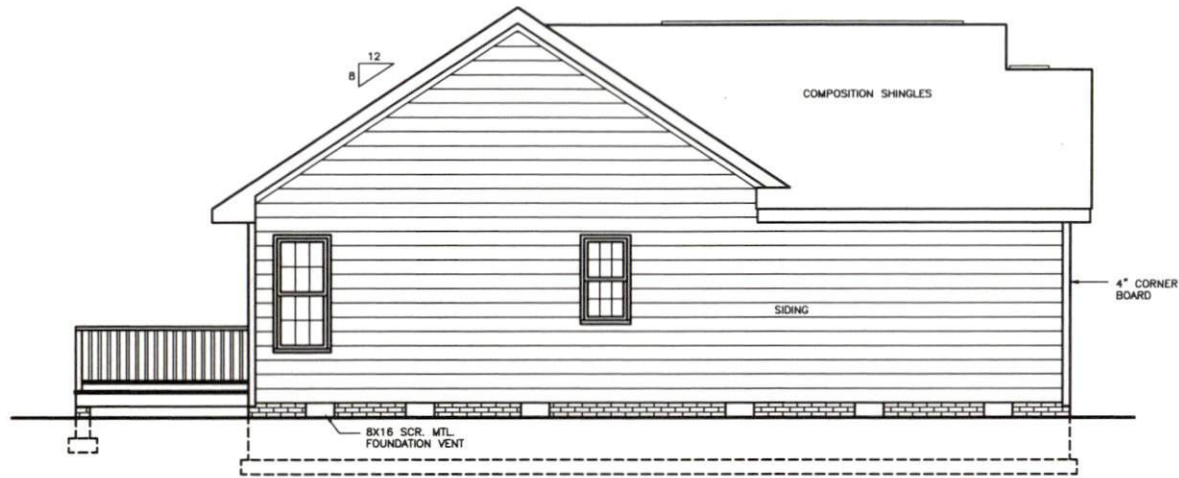

LEFT SIDE ELEVATION  
SCALE : 1/4"=1'-0"



REAR ELEVATION  
SCALE : 1/4"=1'-0"

REVISED 09-22-22



**Standard Homes Plan Service, Inc.**

7200 SUNSET LAKE ROAD FUQUAY-VARINA, NC 27526 (919)552-5677



DESIGNED FOR	PLAN	NO.	MAT'L.	SHOWN	SHEET
	LUTHER	2	SID.		6 OF 8

© 2004 STANDARD HOMES PLAN SERVICE, INC.

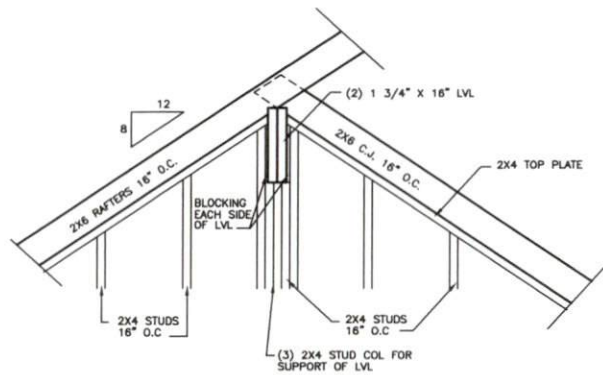

704 SECTION AT SIDE WALL OF LVL  
SCALE: 3/4"=1'-0"

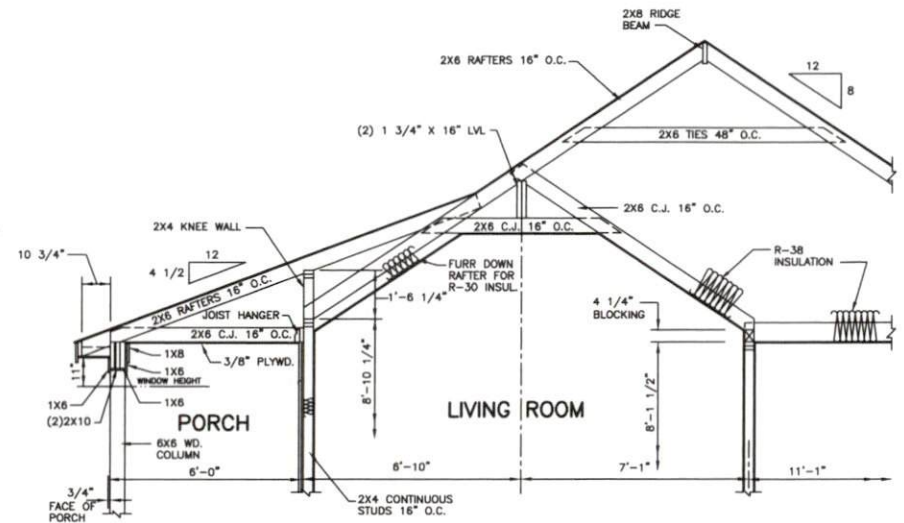

702 SECTION THRU LIVING ROOM VAULTED CEILING  
SCALE: 3/8"=1'-0"

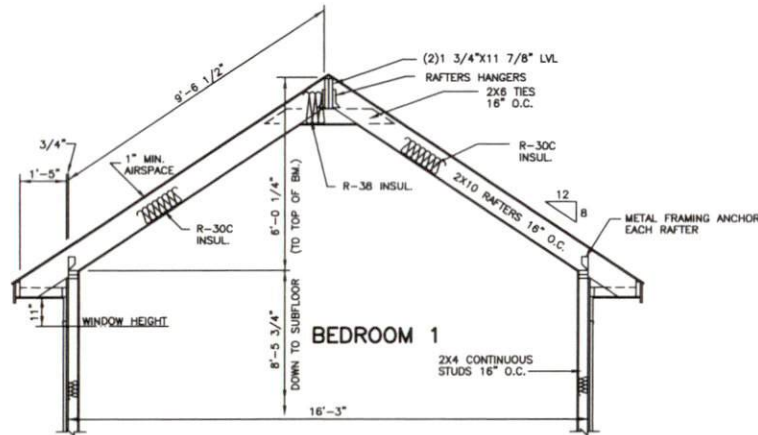

701 SECTION THRU BEDROOM 1 VAULTED CEILING  
SCALE: 3/8"=1'-0"

703 DECK DETAIL  
SCALE: 3/4"=1'-0"

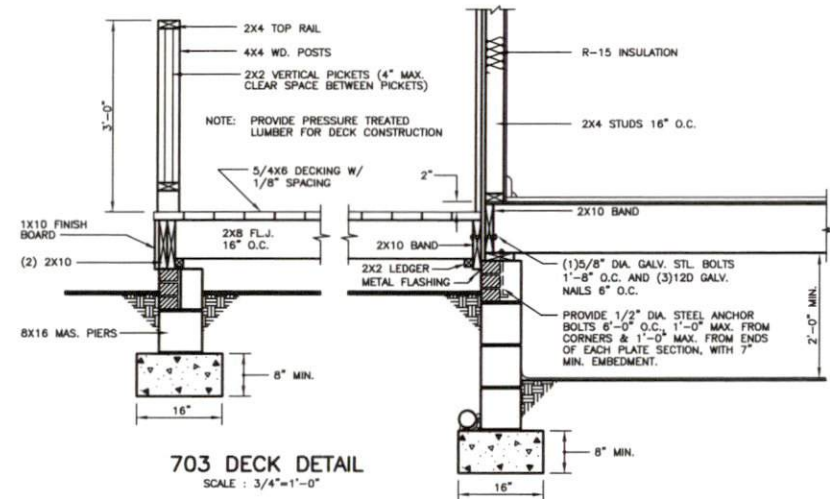

703 DECK DETAIL  
SCALE: 3/4"=1'-0"

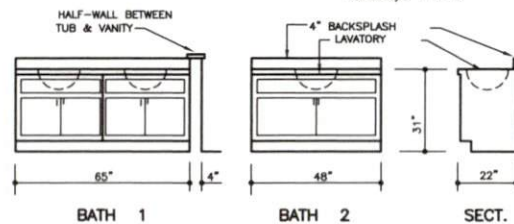

BATH 1

BATH 2

SECT.

REVISED 09-22-22



Standard Homes Plan Service, Inc.

7200 SUNSET LAKE ROAD FUQUAY-VARINA, NC 27526 (919)552-5677



DESIGNED FOR	PLAN	NO.	MAT'L.	SHOWN	SHEET
	LUTHER	2	SID.		7 OF 8

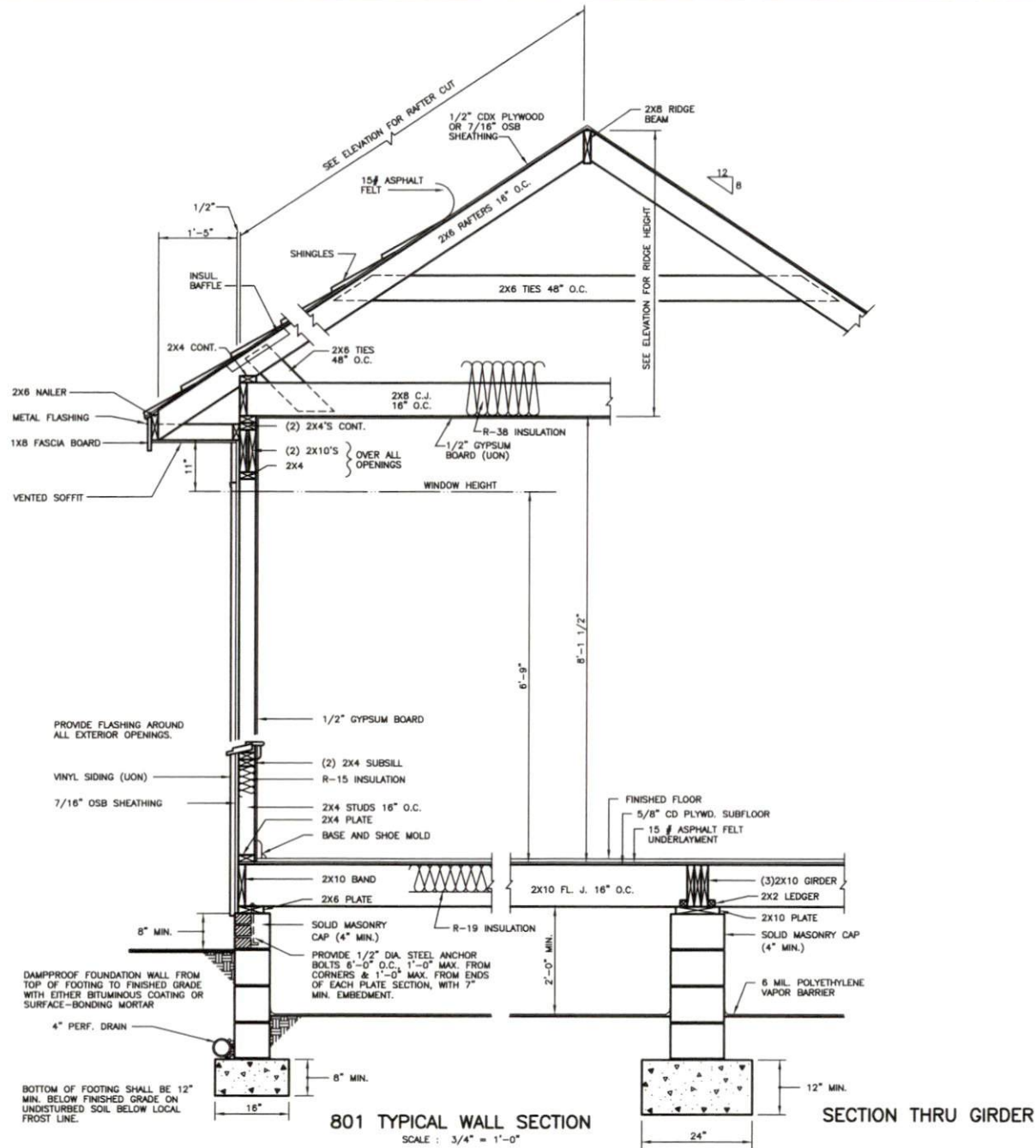

REVISED 09-22-22



**Standard Homes Plan Service, Inc.**

7200 SUNSET LAKE ROAD FUQUAY-VARINA, NC 27526 (919)552-5677



DESIGNED FOR	PLAN	NO.	MAT'L.	SHOWN	SHEET
	LUTHER	2	SID.		8 OF 8



### CONNECTION OF MULTIPLE PLY BEAMS

(INSTALLATION & CONNECTION OF BEAMS SHALL BE ACCORDING TO MANUFACTURERS SPECIFICATIONS)

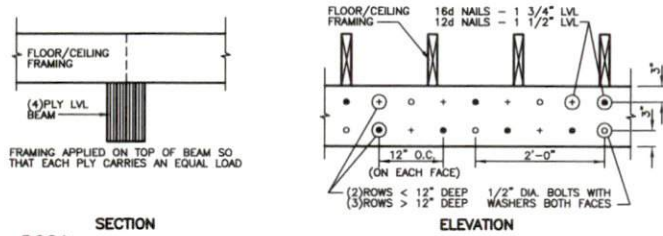

**D001**  
TOP LOADED (4 PILES)

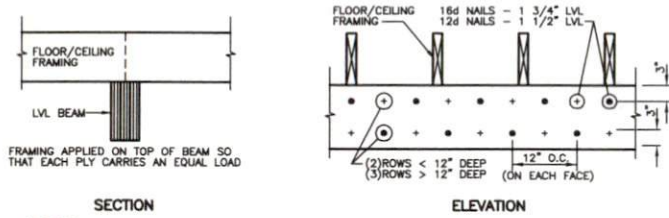

**D002**  
TOP LOADED (3 PILES MAXIMUM)

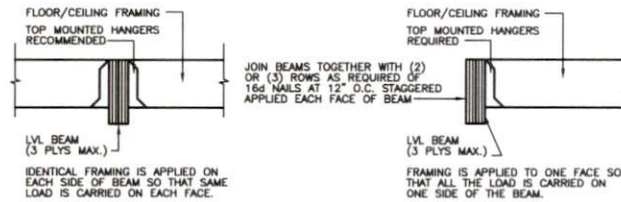

**D003**  
SIDE LOADED

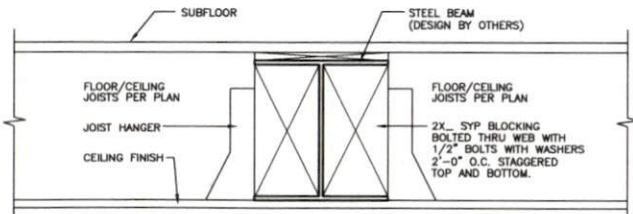

**D004**  
SECTION THRU STEEL BEAM

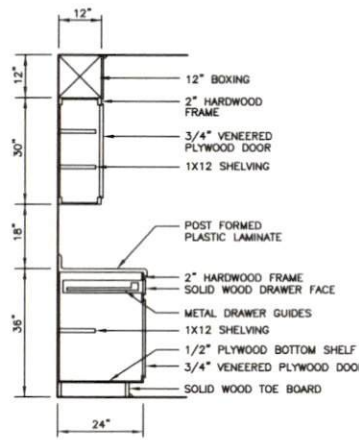

**D005**  
SECTION THRU KITCHEN CABINETS

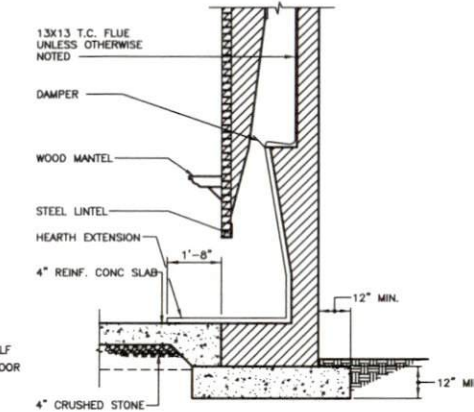

**D006**  
SECT. THRU FIREPLACE ON CONCRETE SLAB

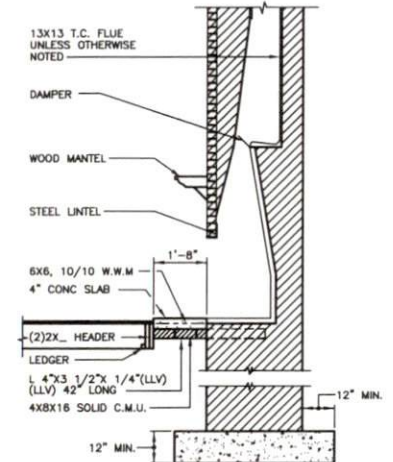

**D007**  
SECT. THRU FIREPLACE ON WOOD FLOOR

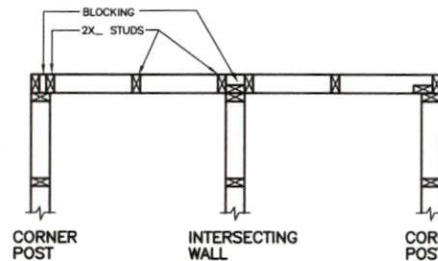

**D008**  
CORNER POST  
D007  
DETAIL BASIC WALL FRAMING

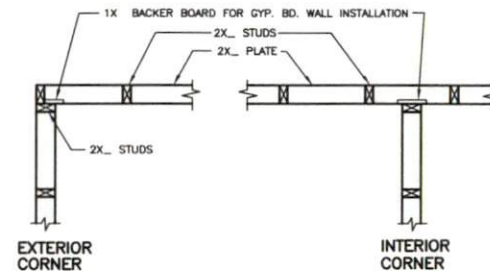

**D009**  
EXTERIOR CORNER  
D008  
DETAIL ADVANCED WALL FRAMING

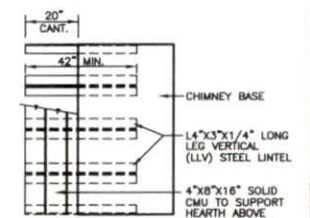

**D010**  
PLAN VIEW OF SUSPENDED HEARTH

MINIMUM UNIFORMLY DISTRIBUTED LIVE LOADS (PSF)	
USE	LIVE LOAD
UNINHABITABLE ATTICS WITHOUT STORAGE	10
UNINHABITABLE ATTICS WITH LIMITED STORAGE	20
HABITABLE ATTICS AND ATTICS SERVED WITH FIXED STAIRS	30
BALCONIES AND DECKS	40
ROOMS OTHER THAN SLEEPING ROOMS	40
SLEEPING ROOMS	30
STAIRS	40

ALLOWABLE DEFLECTION OF STRUCTURAL MEMBERS (NOTE : L = SPAN LENGTH)	
STRUCTURAL MEMBER	ALLOWABLE DEFLECTION
RAFTERS HAVING SLOPES GREATER THAN 3:12 WITH FINISHED CEILING NOT ATTACHED TO RAFTERS	L/180
FLOORS	L/360
CEILING WITH BRITTLE FINISHES (INCLUDING PLASTER AND STUCCO)	L/360
CEILING WITH FLEXIBLE FINISHES (INCLUDING GYPSUM BOARD)	L/240
ALL OTHER STRUCTURAL MEMBERS	L/240
LINTELS SUPPORTING MASONRY VENEER WALLS	L/600



**Standard Homes Plan Service, Inc.**

7200 SUNSET LAKE ROAD FUQUAY-VARINA, NC 27526 (919)552-5677

SEE HOME DESIGN PREVIEWS ONLINE AT WWW.STANDARHHOMES.COM



STANDARD CONSTRUCTION DETAILS

D