

Trenco
818 Soundside Rd
Edenton, NC 27932

Re: P-8062-1
149 Dauphine St-Roof

The truss drawing(s) referenced below have been prepared by Truss Engineering Co. under my direct supervision based on the parameters provided by Peak Truss Builders, LLC(Closed).

Pages or sheets covered by this seal: I47987434 thru I47987439

My license renewal date for the state of North Carolina is December 31, 2021.

North Carolina COA: C-0844



September 21, 2021

Sevier, Scott

IMPORTANT NOTE: The seal on these truss component designs is a certification that the engineer named is licensed in the jurisdiction(s) identified and that the designs comply with ANSI/TPI 1. These designs are based upon parameters shown (e.g., loads, supports, dimensions, shapes and design codes), which were given to MiTek or TRENCO. Any project specific information included is for MiTek's or TRENCO's customers file reference purpose only, and was not taken into account in the preparation of these designs. MiTek or TRENCO has not independently verified the applicability of the design parameters or the designs for any particular building. Before use, the building designer should verify applicability of design parameters and properly incorporate these designs into the overall building design per ANSI/TPI 1, Chapter 2.

Job P-8062-1	Truss T1	Truss Type Common	Qty 22	Ply 1	149 Dauphine St-Roof Job Reference (optional)	147987434
-----------------	-------------	----------------------	-----------	----------	--	-----------

Peak Truss Builders, LLC (Closed), New Hill, NC - 27562,

Run: 8.43 S Aug 16 2021 Print: 8.430 S Aug 16 2021 MiTek Industries, Inc. Mon Sep 20 15:13:57
ID:5fca9kZ0d0FRnXr3qx9FmeyjNp2-RfC?PsB70Hq3NSgPqnL8w3ulTXbGKWrCDoi7J4zJC?f

Page: 1

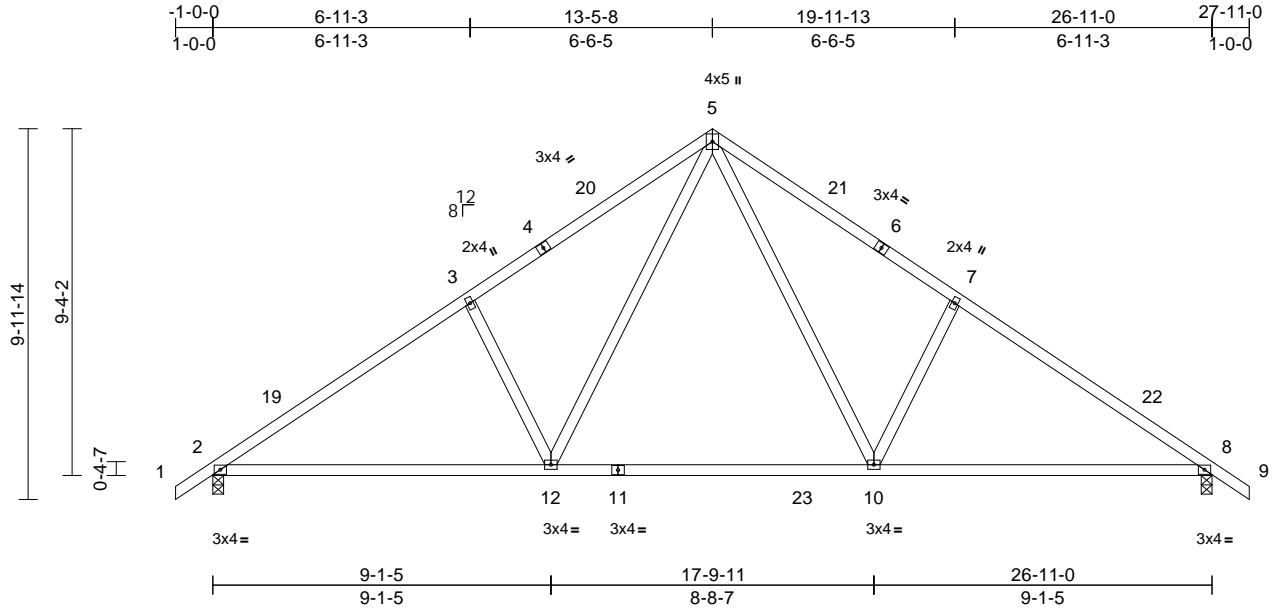

Loading	(psf)	Spacing	2-0-0	CSI	DEFL	in	(loc)	l/defl	L/d	PLATES	GRIP	
TCLL (roof)	20.0	Plate Grip DOL	1.15	TC	0.47	Vert(LL)	-0.26	10-12	>999	240	MT20	244/190
TCDL	10.0	Lumber DOL	1.15	BC	0.57	Vert(CT)	-0.33	10-12	>968	180		
BCLL	0.0*	Rep Stress Incr	YES	WB	0.26	Horz(CT)	0.04	8	n/a	n/a		
BCDL	10.0	Code	IRC2015/TPI2014	Matrix-MS								Weight: 136 lb FT = 20%

LUMBER
 TOP CHORD 2x4 SP No.1
 BOT CHORD 2x4 SP No.1
 WEBS 2x4 SP No.3

BRACING
 TOP CHORD Structural wood sheathing directly applied or 4-7-1 oc purlins.
 BOT CHORD Rigid ceiling directly applied or 10-0-0 oc bracing.

REACTIONS (lb/size) 2=1137/0-3-8, 8=1137/0-3-8
 Max Horiz 2=159 (LC 10)
 Max Uplift 2=-127 (LC 11), 8=-127 (LC 11)

FORCES (lb) - Maximum Compression/Maximum Tension
 TOP CHORD 1-2=0/33, 2-3=-1549/182, 3-5=-1408/252, 5-7=-1408/252, 7-8=-1549/182, 8-9=0/33
 BOT CHORD 2-12=-32/1319, 10-12=0/854, 8-10=-32/1236
 WEBS 5-10=-80/690, 7-10=-394/195, 5-12=-80/692, 3-12=-394/195

- NOTES**
- Unbalanced roof live loads have been considered for this design.
 - Wind: ASCE 7-10; Vult=115mph (3-second gust) Vasd=91mph; TCDL=6.0psf; BCDL=6.0psf; h=30ft; B=20ft; L=27ft; eave=4ft; Cat. II; Exp B; Enclosed; MWFRS (directional) and C-C Exterior (2) -1-0-0 to 2-0-0, Interior (1) 2-0-0 to 13-5-8, Exterior (2) 13-5-8 to 16-5-8, Interior (1) 16-5-8 to 27-11-0 zone; cantilever left and right exposed; end vertical left and right exposed; C-C for members and forces & MWFRS for reactions shown; Lumber DOL=1.60 plate grip DOL=1.60
 - * This truss has been designed for a live load of 20.0psf on the bottom chord in all areas where a rectangle 3-06-00 tall by 2-00-00 wide will fit between the bottom chord and any other members, with BCDL = 10.0psf.
 - Provide mechanical connection (by others) of truss to bearing plate capable of withstanding 127 lb uplift at joint 2 and 127 lb uplift at joint 8.



September 21, 2021

WARNING - Verify design parameters and READ NOTES ON THIS AND INCLUDED MITEK REFERENCE PAGE MII-7473 rev. 5/19/2020 BEFORE USE.

Design valid for use only with MiTek® connectors. This design is based only upon parameters shown, and is for an individual building component, not a truss system. Before use, the building designer must verify the applicability of design parameters and properly incorporate this design into the overall building design. Bracing indicated is to prevent buckling of individual truss web and/or chord members only. Additional temporary and permanent bracing is always required for stability and to prevent collapse with possible personal injury and property damage. For general guidance regarding the fabrication, storage, delivery, erection and bracing of trusses and truss systems, see

ANSI/TPI1 Quality Criteria, DSB-89 and BCSI Building Component

Safety Information available from Truss Plate Institute, 2670 Crain Highway, Suite 203 Waldorf, MD 20601



818 Soundside Road
Edenton, NC 27932

Job P-8062-1	Truss T1GE	Truss Type Common Supported Gable	Qty 2	Ply 1	149 Dauphine St-Roof Job Reference (optional)	147987435
-----------------	---------------	--------------------------------------	----------	----------	--	-----------

Peak Truss Builders, LLC (Closed), New Hill, NC - 27562,

Run: 8.43 S Aug 16 2021 Print: 8.430 S Aug 16 2021 MiTek Industries, Inc. Mon Sep 20 15:13:59
ID:5fca9kZoD0fRnXr3qx9FmeyjNp2-RfC?PsB70Hq3NSgPqnL8w3uTXbGKwRCDoi7J4zJC?f

Page: 1

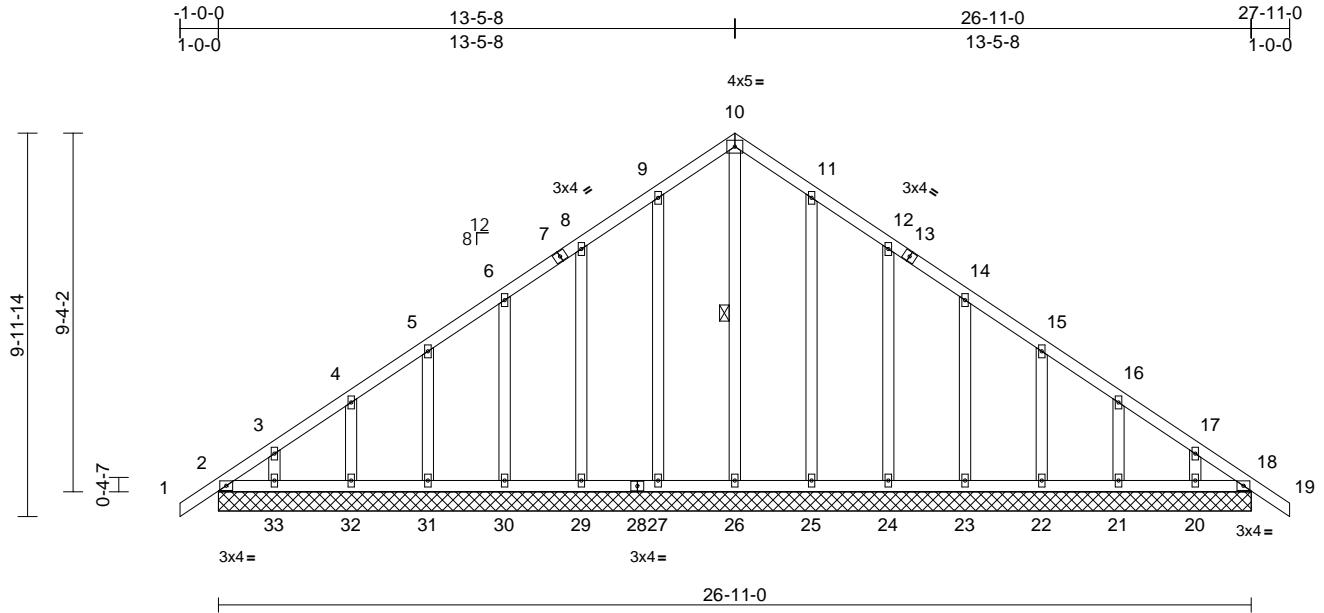

Scale = 1:60

Loading	(psf)	Spacing	2-0-0	CSI	DEFL	in	(loc)	l/defl	L/d	PLATES	GRIP	
TCLL (roof)	20.0	Plate Grip DOL	1.15	TC	0.05	Vert(LL)	n/a	-	n/a	999	MT20	244/190
TCDL	10.0	Lumber DOL	1.15	BC	0.02	Vert(CT)	n/a	-	n/a	999		
BCLL	0.0*	Rep Stress Incr	YES	WB	0.15	Horz(CT)	0.01	18	n/a	n/a		
BCDL	10.0	Code	IRC2015/TPI2014	Matrix-S							Weight: 179 lb	FT = 20%

LUMBER
TOP CHORD 2x4 SP No.1
BOT CHORD 2x4 SP No.1
OTHERS 2x4 SP No.3

BRACING
TOP CHORD Structural wood sheathing directly applied or 6-0-0 oc purlins.
BOT CHORD Rigid ceiling directly applied or 10-0-0 oc bracing.

WEBS 1 Row at midpt 10-26

REACTIONS (lb/size) 2=139/26-11-0, 18=139/26-11-0, 20=124/26-11-0, 21=167/26-11-0, 22=158/26-11-0, 23=160/26-11-0, 24=159/26-11-0, 25=165/26-11-0, 26=127/26-11-0, 27=165/26-11-0, 29=159/26-11-0, 30=160/26-11-0, 31=158/26-11-0, 32=167/26-11-0, 33=124/26-11-0

Max Horiz 2=-159 (LC 9)

Max Uplift 2=-8 (LC 7), 20=-21 (LC 11), 21=-46 (LC 11), 22=-41 (LC 11), 23=-41 (LC 11), 24=-46 (LC 11), 25=-33 (LC 11), 27=-33 (LC 11), 29=-46 (LC 11), 30=-41 (LC 11), 31=-41 (LC 11), 32=-46 (LC 11), 33=-21 (LC 11)

Max Grav 2=149 (LC 17), 18=139 (LC 1), 20=126 (LC 17), 21=167 (LC 21), 22=158 (LC 21), 23=160 (LC 1), 24=159 (LC 1), 25=167 (LC 21), 26=176 (LC 11), 27=167 (LC 20), 29=159 (LC 1), 30=160 (LC 1), 31=158 (LC 20), 32=167 (LC 20), 33=127 (LC 16)

FORCES (lb) - Maximum Compression/Maximum Tension

TOP CHORD 1-2=0/31, 2-3=-125/116, 3-4=-118/107, 4-5=-110/92, 5-6=-100/79, 6-8=-91/87, 8-9=-119/139, 9-10=-155/184, 10-11=-155/184, 11-12=-119/139, 12-14=-80/87, 14-15=-58/37, 15-16=-68/36, 16-17=-77/65, 17-18=-116/103, 18-19=0/31
BOT CHORD 2-33=89/137, 32-33=89/137, 31-32=89/137, 30-31=89/137, 29-30=89/137, 27-29=89/137, 26-27=89/137, 25-26=89/137, 24-25=89/137, 23-24=89/137, 22-23=89/137, 21-22=89/137, 20-21=89/137, 18-20=89/137
WEBS 10-26=-152/71, 9-27=-127/57, 8-29=-119/70, 6-30=-120/65, 5-31=-119/65, 4-32=-125/69, 3-33=-106/51, 11-25=-127/57, 12-24=-119/70, 14-23=-120/65, 15-22=-119/65, 16-21=-125/69, 17-20=-106/51

NOTES

- 1) Unbalanced roof live loads have been considered for this design.
- 2) Wind: ASCE 7-10; Vult=115mph (3-second gust) Vasd=91mph; TCDL=6.0psf; BCDL=6.0psf; h=30ft; B=20ft; L=27ft; eave=2ft; Cat. II; Exp B; Enclosed; MWFRS (directional) and C-C Corner (3) -1-0-0 to 2-0-0, Exterior (2) 2-0-0 to 13-5-8, Corner (3) 13-5-8 to 16-5-8, Exterior (2) 16-5-8 to 27-11-0 zone; cantilever left and right exposed; end vertical left and right exposed; C-C for members and forces & MWFRS for reactions shown; Lumber DOL=1.60 plate grip DOL=1.60
- 3) Truss designed for wind loads in the plane of the truss only. For studs exposed to wind (normal to the face), see Standard Industry Gable End Details as applicable, or consult qualified building designer as per ANSI/TPI 1.
- 4) All plates are 2x4 MT20 unless otherwise indicated.
- 5) Gable requires continuous bottom chord bearing.
- 6) Gable studs spaced at 2-0-0 oc.

- 7) * This truss has been designed for a live load of 20.0psf on the bottom chord in all areas where a rectangle 3-06-00 tall by 2-00-00 wide will fit between the bottom chord and any other members.
- 8) Provide mechanical connection (by others) of truss to bearing plate capable of withstanding 8 lb uplift at joint 2, 33 lb uplift at joint 27, 46 lb uplift at joint 29, 41 lb uplift at joint 30, 41 lb uplift at joint 31, 46 lb uplift at joint 32, 21 lb uplift at joint 33, 33 lb uplift at joint 25, 46 lb uplift at joint 24, 41 lb uplift at joint 23, 41 lb uplift at joint 22, 46 lb uplift at joint 21 and 21 lb uplift at joint 20.

LOAD CASE(S) Standard



September 21, 2021

WARNING - Verify design parameters and READ NOTES ON THIS AND INCLUDED MITEK REFERENCE PAGE MII-7473 rev. 5/19/2020 BEFORE USE.

Design valid for use only with MiTek® connectors. This design is based only upon parameters shown, and is for an individual building component, not a truss system. Before use, the building designer must verify the applicability of design parameters and properly incorporate this design into the overall building design. Bracing indicated is to prevent buckling of individual truss web and/or chord members only. Additional temporary and permanent bracing is always required for stability and to prevent collapse with possible personal injury and property damage. For general guidance regarding the fabrication, storage, delivery, erection and bracing of trusses and truss systems, see ANSITPI Quality Criteria, DSB-89 and BCSI Building Component Safety Information available from Truss Plate Institute, 2670 Crain Highway, Suite 203 Waldorf, MD 20601



818 Soundside Road
Edenton, NC 27932

Job P-8062-1	Truss V1	Truss Type Valley	Qty 1	Ply 1	149 Dauphine St-Roof Job Reference (optional)	147987436
-----------------	-------------	----------------------	----------	----------	--	-----------

Peak Truss Builders, LLC (Closed), New Hill, NC - 27562,

Run: 8.43 S Aug 16 2021 Print: 8.430 S Aug 16 2021 MiTek Industries, Inc. Mon Sep 20 15:13:59
ID:5fca9kZoD0fRnXr3qx9FmeyjNp2-RfC?PsB70Hq3NSgPqnL8w3u1TXbGKWrCDoi7J4zJC?f

Page: 1

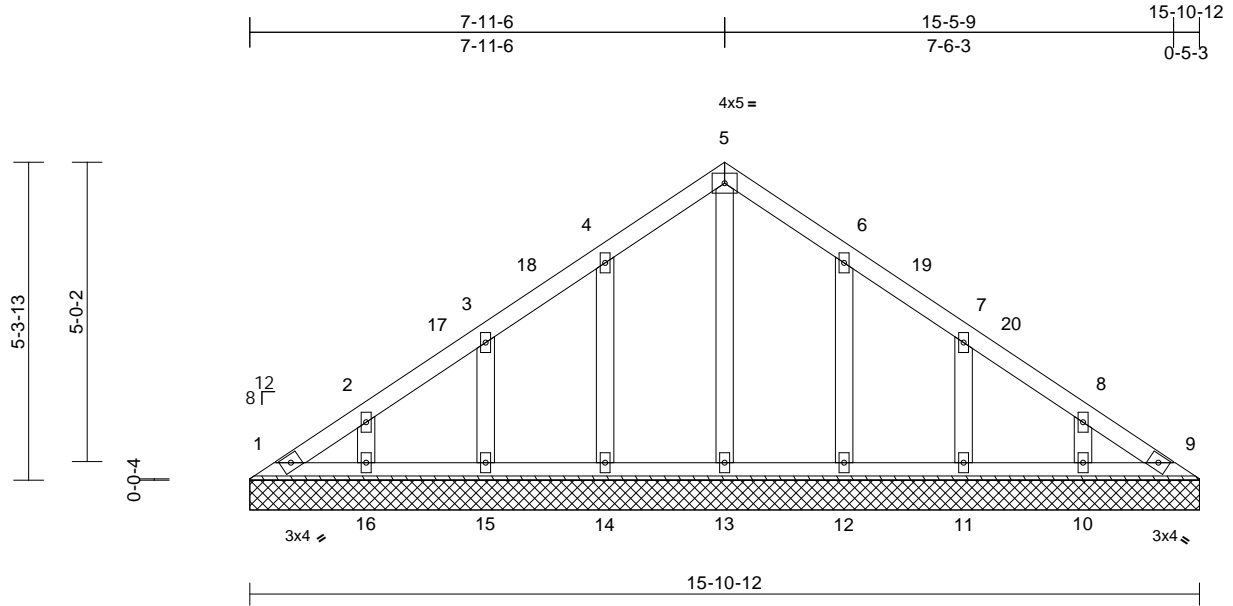

Scale = 1:38.6

Loading	(psf)	Spacing	2-0-0	CSI	DEFL	in	(loc)	l/defl	L/d	PLATES	GRIP	
TCLL (roof)	20.0	Plate Grip DOL	1.15	TC	0.04	Vert(LL)	n/a	-	n/a	999	MT20	244/190
TCDL	10.0	Lumber DOL	1.15	BC	0.01	Vert(TL)	n/a	-	n/a	999		
BCLL	0.0*	Rep Stress Incr	YES	WB	0.04	Horiz(TL)	0.00	9	n/a	n/a		
BCDL	10.0	Code	IRC2015/TPI2014	Matrix-S							Weight: 76 lb	FT = 20%

LUMBER

TOP CHORD 2x4 SP No.1
BOT CHORD 2x4 SP No.1
OTHERS 2x4 SP No.3

BRACING

TOP CHORD Structural wood sheathing directly applied or 6-0-0 oc purlins.
BOT CHORD Rigid ceiling directly applied or 10-0-0 oc bracing.

REACTIONS

(lb/size) 1=55/15-10-12, 9=55/15-10-12,
10=156/15-10-12,
11=160/15-10-12,
12=166/15-10-12,
13=126/15-10-12,
14=166/15-10-12,
15=160/15-10-12,
16=156/15-10-12
Max Horiz 1=-82 (LC 9)
Max Uplift 1=-3 (LC 9), 10=-40 (LC 11),
11=-43 (LC 11), 12=-41 (LC 11),
14=-41 (LC 11), 15=-43 (LC 11),
16=-40 (LC 11)
Max Grav 1=69 (LC 17), 9=57 (LC 16),
10=156 (LC 21), 11=160 (LC 1),
12=168 (LC 21), 13=126 (LC 1),
14=168 (LC 20), 15=160 (LC 1),
16=156 (LC 20)

FORCES

(lb) - Maximum Compression/Maximum Tension

TOP CHORD 1-2=-74/64, 2-3=-80/52, 3-4=-71/46,
4-5=-91/95, 5-6=-91/95, 6-7=-54/46,
7-8=-59/25, 8-9=-63/45
BOT CHORD 1-16=-38/61, 15-16=-38/61, 14-15=-38/61,
13-14=-38/61, 12-13=-38/61, 11-12=-38/61,
10-11=-38/61, 9-10=-38/61
WEBS 5-13=-86/5, 4-14=-128/65, 3-15=-120/68,
2-16=-115/61, 6-12=-128/65, 7-11=-120/68,
8-10=-115/61

NOTES

- Unbalanced roof live loads have been considered for this design.
- Wind: ASCE 7-10; Vult=115mph (3-second gust) Vasd=91mph; TC DL=6.0psf; BC DL=6.0psf; h=30ft; B=20ft; L=20ft; eave=4ft; Cat. II; Exp B; Enclosed; MWFRS (directional) and C-C Exterior (2) 0-5-12 to 3-5-12, Interior (1) 3-5-12 to 7-11-12, Exterior (2) 7-11-12 to 10-11-12, Interior (1) 10-11-12 to 15-5-12 zone; cantilever left and right exposed; end vertical left and right exposed; C-C for members and forces & MWFRS for reactions shown; Lumber DOL=1.60 plate grip DOL=1.60
- Truss designed for wind loads in the plane of the truss only. For studs exposed to wind (normal to the face), see Standard Industry Gable End Details as applicable, or consult qualified building designer as per ANSI/TPI 1.
- All plates are 2x4 MT20 unless otherwise indicated.
- Gable requires continuous bottom chord bearing.
- Gable studs spaced at 2-0-0 oc.
- * This truss has been designed for a live load of 20.0psf on the bottom chord in all areas where a rectangle 3-06-00 tall by 2-00-00 wide will fit between the bottom chord and any other members.
- Provide mechanical connection (by others) of truss to bearing plate capable of withstanding 3 lb uplift at joint 1, 41 lb uplift at joint 14, 43 lb uplift at joint 15, 40 lb uplift at joint 16, 41 lb uplift at joint 12, 43 lb uplift at joint 11 and 40 lb uplift at joint 10.

LOAD CASE(S) Standard

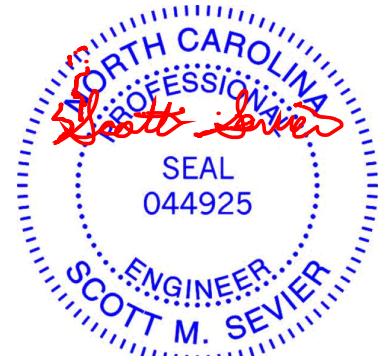

September 21, 2021

WARNING - Verify design parameters and READ NOTES ON THIS AND INCLUDED MITEK REFERENCE PAGE MII-7473 rev. 5/19/2020 BEFORE USE.

Design valid for use only with MiTek® connectors. This design is based only upon parameters shown, and is for an individual building component, not a truss system. Before use, the building designer must verify the applicability of design parameters and properly incorporate this design into the overall building design. Bracing indicated is to prevent buckling of individual truss web and/or chord members only. Additional temporary and permanent bracing is always required for stability and to prevent collapse with possible personal injury and property damage. For general guidance regarding the fabrication, storage, delivery, erection and bracing of trusses and truss systems, see **ANSI/TPI1 Quality Criteria, DSB-89 and BCSI Building Component Safety Information** available from Truss Plate Institute, 2670 Crain Highway, Suite 203 Waldorf, MD 20601



818 Soundside Road
Edenton, NC 27932

Job P-8062-1	Truss V2	Truss Type Valley	Qty 1	Ply 1	149 Dauphine St-Roof Job Reference (optional)	147987437
-----------------	-------------	----------------------	----------	----------	--	-----------

Peak Truss Builders, LLC (Closed), New Hill, NC - 27562,

Run: 8.43 S Aug 16 2021 Print: 8.430 S Aug 16 2021 MiTek Industries, Inc. Mon Sep 20 15:13:59
ID:5fca9kZoD0fRnXr3qx9FmeyjNp2-RfC?PsB70Hq3NSgPqnL8w3ulTXbGKwRCDoi7J4zJC?f

Page: 1

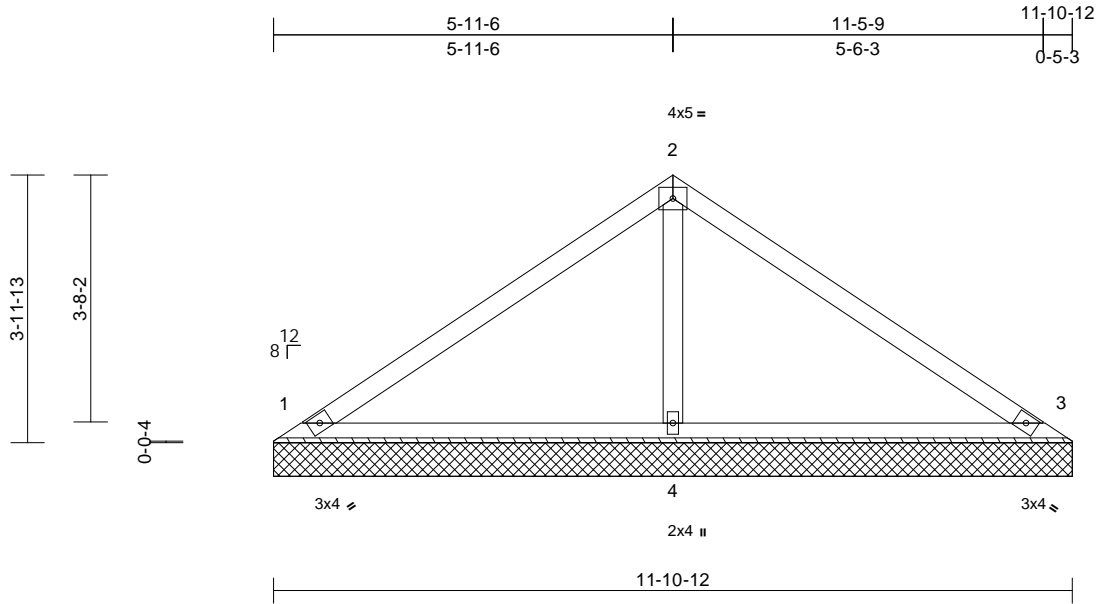

Scale = 1:34.3

Loading	(psf)	Spacing	2-0-0	CSI	DEFL	in	(loc)	l/defl	L/d	PLATES	GRIP	
TCLL (roof)	20.0	Plate Grip DOL	1.15	TC	0.32	Vert(LL)	n/a	-	n/a	999	MT20	244/190
TCDL	10.0	Lumber DOL	1.15	BC	0.17	Vert(TL)	n/a	-	n/a	999		
BCLL	0.0*	Rep Stress Incr	YES	WB	0.08	Horiz(TL)	0.00	3	n/a	n/a		
BCDL	10.0	Code	IRC2015/TPI2014	Matrix-S							Weight: 42 lb	FT = 20%

LUMBER

TOP CHORD 2x4 SP No.1
BOT CHORD 2x4 SP No.1
OTHERS 2x4 SP No.3

BRACING

TOP CHORD Structural wood sheathing directly applied or 6-0-0 oc purlins.
BOT CHORD Rigid ceiling directly applied or 10-0-0 oc bracing.

REACTIONS

(lb/size) 1=220/11-10-12, 3=220/11-10-12, 4=439/11-10-12
Max Horiz 1=60 (LC 10)
Max Uplift 1=-37 (LC 11), 3=-37 (LC 11), 4=-4 (LC 11)

FORCES

(lb) - Maximum Compression/Maximum Tension
TOP CHORD 1-2=-155/58, 2-3=-155/58
BOT CHORD 1-4=-1/65, 3-4=-1/65
WEBS 2-4=-277/66

NOTES

- Unbalanced roof live loads have been considered for this design.
- Wind: ASCE 7-10; Vult=115mph (3-second gust) Vasd=91mph; TCDL=6.0psf; BCDL=6.0psf; h=30ft; B=20ft; L=20ft; eave=2ft; Cat. II; Exp B; Enclosed; MWFRS (directional) and C-C Corner (3) 0-5-12 to 3-5-12, Exterior (2) 3-5-12 to 5-11-12, Corner (3) 5-11-12 to 8-11-12, Exterior (2) 8-11-12 to 11-5-12 zone; cantilever left and right exposed; end vertical left and right exposed; C-C for members and forces & MWFRS for reactions shown; Lumber DOL=1.60 plate grip DOL=1.60
- Truss designed for wind loads in the plane of the truss only. For studs exposed to wind (normal to the face), see Standard Industry Gable End Details as applicable, or consult qualified building designer as per ANSI/TPI 1.
- Gable requires continuous bottom chord bearing.
- Gable studs spaced at 4-0-0 oc.

- * This truss has been designed for a live load of 20.0psf on the bottom chord in all areas where a rectangle 3-06-00 tall by 2-00-00 wide will fit between the bottom chord and any other members.
- Provide mechanical connection (by others) of truss to bearing plate capable of withstanding 37 lb uplift at joint 1, 37 lb uplift at joint 3 and 4 lb uplift at joint 4.

LOAD CASE(S) Standard



September 21, 2021

WARNING - Verify design parameters and READ NOTES ON THIS AND INCLUDED MITEK REFERENCE PAGE MII-7473 rev. 5/19/2020 BEFORE USE.

Design valid for use only with MiTek® connectors. This design is based only upon parameters shown, and is for an individual building component, not a truss system. Before use, the building designer must verify the applicability of design parameters and properly incorporate this design into the overall building design. Bracing indicated is to prevent buckling of individual truss web and/or chord members only. Additional temporary and permanent bracing is always required for stability and to prevent collapse with possible personal injury and property damage. For general guidance regarding the fabrication, storage, delivery, erection and bracing of trusses and truss systems, see ANSI/TPI1 Quality Criteria, DSB-89 and BCSI Building Component Safety Information available from Truss Plate Institute, 2670 Crain Highway, Suite 203 Waldorf, MD 20601



818 Soundside Road
Edenton, NC 27932

Job P-8062-1	Truss V3	Truss Type Valley	Qty 1	Ply 1	149 Dauphine St-Roof Job Reference (optional)	147987438
-----------------	-------------	----------------------	----------	----------	--	-----------

Peak Truss Builders, LLC (Closed), New Hill, NC - 27562,

Run: 8.43 S Aug 16 2021 Print: 8.430 S Aug 16 2021 MiTek Industries, Inc. Mon Sep 20 15:14:00
ID:5fca9kZoD0FRnXr3qx9FmeyjNp2-RfC?PsB70Hq3NSgPqnL8w3uTXbGKWrCDoi7J4zJC?#

Page: 1

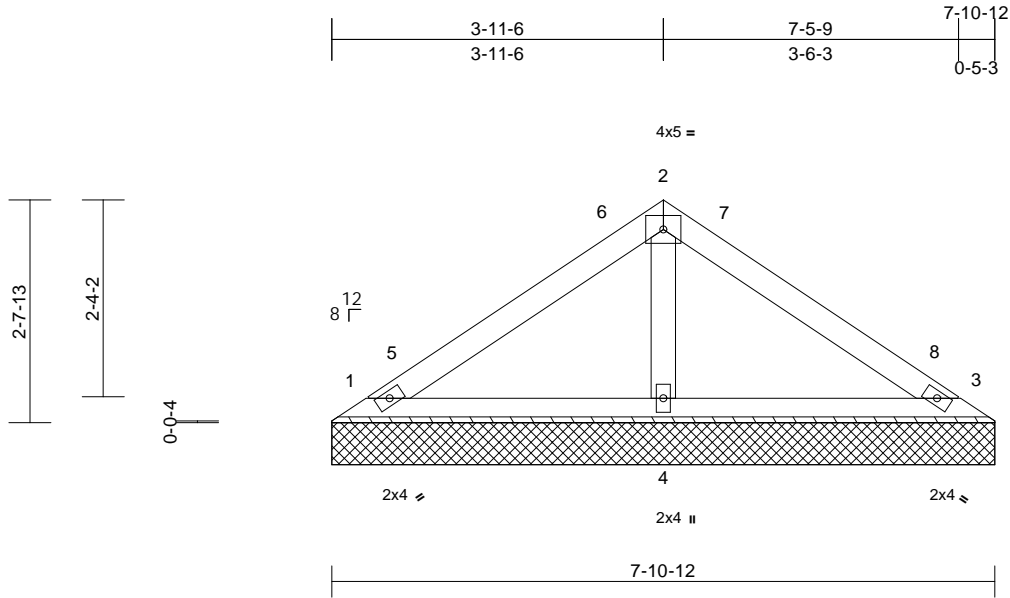

Scale = 1:27.4

Loading	(psf)	Spacing	2-0-0	CSI	DEFL	in	(loc)	l/defl	L/d	PLATES	GRIP	
TCLL (roof)	20.0	Plate Grip DOL	1.15	TC	0.17	Vert(LL)	n/a	-	n/a	999	MT20	244/190
TCDL	10.0	Lumber DOL	1.15	BC	0.06	Vert(TL)	n/a	-	n/a	999		
BCLL	0.0*	Rep Stress Incr	YES	WB	0.04	Horiz(TL)	0.00	3	n/a	n/a		
BCDL	10.0	Code	IRC2015/TPI2014	Matrix-P							Weight: 27 lb	FT = 20%

LUMBER

TOP CHORD 2x4 SP No.1
BOT CHORD 2x4 SP No.1
OTHERS 2x4 SP No.3

BRACING

TOP CHORD Structural wood sheathing directly applied or 6-0-0 oc purlins.
BOT CHORD Rigid ceiling directly applied or 10-0-0 oc bracing.

REACTIONS (lb/size) 1=153/7-10-12, 3=153/7-10-12, 4=253/7-10-12

Max Horiz 1=-38 (LC 9)
Max Uplift 1=-32 (LC 11), 3=-32 (LC 11)

FORCES (lb) - Maximum Compression/Maximum Tension

TOP CHORD 1-2=-86/35, 2-3=-86/35
BOT CHORD 1-4=-3/38, 3-4=-3/38
WEBS 2-4=-166/39

NOTES

- Unbalanced roof live loads have been considered for this design.
- Wind: ASCE 7-10; Vult=115mph (3-second gust) Vasd=91mph; TCDL=6.0psf; BCDL=6.0psf; h=30ft; B=20ft; L=20ft; eave=4ft; Cat. II; Exp B; Enclosed; MWFRS (directional) and C-C Exterior (2) 0-5-12 to 3-5-12, Interior (1) 3-5-12 to 3-11-12, Exterior (2) 3-11-12 to 6-11-12, Interior (1) 6-11-12 to 7-5-12 zone; cantilever left and right exposed; end vertical left and right exposed; C-C for members and forces & MWFRS for reactions shown; Lumber DOL=1.60 plate grip DOL=1.60
- Truss designed for wind loads in the plane of the truss only. For studs exposed to wind (normal to the face), see Standard Industry Gable End Details as applicable, or consult qualified building designer as per ANSI/TPI 1.
- Gable requires continuous bottom chord bearing.
- Gable studs spaced at 2-0-0 oc.

- * This truss has been designed for a live load of 20.0psf on the bottom chord in all areas where a rectangle 3-06-00 tall by 2-00-00 wide will fit between the bottom chord and any other members.
- Provide mechanical connection (by others) of truss to bearing plate capable of withstanding 32 lb uplift at joint 1 and 32 lb uplift at joint 3.

LOAD CASE(S) Standard



September 21, 2021

WARNING - Verify design parameters and READ NOTES ON THIS AND INCLUDED MITEK REFERENCE PAGE MII-7473 rev. 5/19/2020 BEFORE USE.

Design valid for use only with MiTek® connectors. This design is based only upon parameters shown, and is for an individual building component, not a truss system. Before use, the building designer must verify the applicability of design parameters and properly incorporate this design into the overall building design. Bracing indicated is to prevent buckling of individual truss web and/or chord members only. Additional temporary and permanent bracing is always required for stability and to prevent collapse with possible personal injury and property damage. For general guidance regarding the fabrication, storage, delivery, erection and bracing of trusses and truss systems, see

ANSI/TPI1 Quality Criteria, DSB-89 and BCSI Building Component

Safety Information available from Truss Plate Institute, 2670 Crain Highway, Suite 203 Waldorf, MD 20601

ENGINEERING BY
TRENCO
A MiTek Affiliate

818 Soundside Road
Edenton, NC 27932

Job P-8062-1	Truss V4	Truss Type Valley	Qty 1	Ply 1	149 Dauphine St-Roof Job Reference (optional)	147987439
-----------------	-------------	----------------------	----------	----------	--	-----------

Peak Truss Builders, LLC (Closed), New Hill, NC - 27562,

Run: 8.43 S Aug 16 2021 Print: 8.430 S Aug 16 2021 MiTek Industries, Inc. Mon Sep 20 15:14:00
ID:5fca9kZoD0fRnXr3qx9FmeyjNp2-RfC?PsB70Hq3NSgPqnL8w3ulTXbGKwRCDoi7J4zJC?#

Page: 1

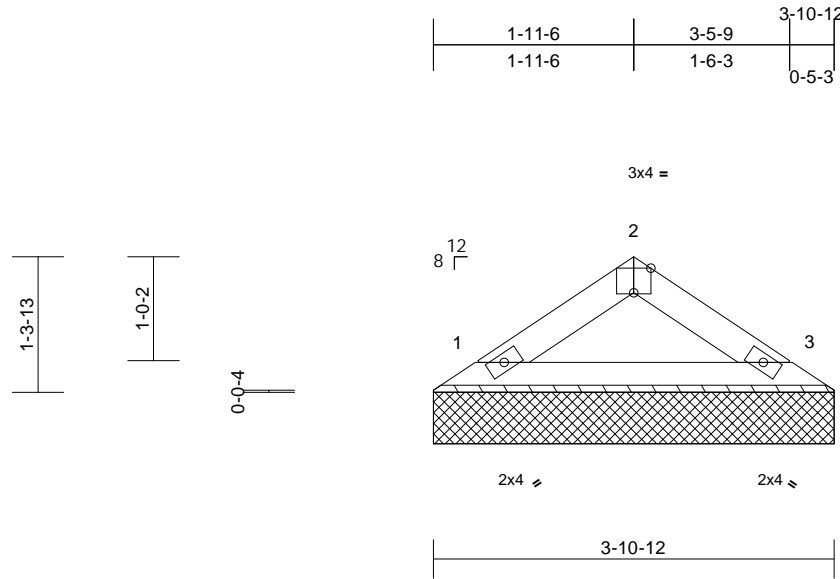

Scale = 1:22.4

Plate Offsets (X, Y): [2:0-2-0,Edge]

Loading	(psf)	Spacing	2-0-0	CSI	DEFL	in	(loc)	l/defl	L/d	PLATES	GRIP	
TCLL (roof)	20.0	Plate Grip DOL	1.15	TC	0.03	Vert(LL)	n/a	-	n/a	999	MT20	244/190
TCDL	10.0	Lumber DOL	1.15	BC	0.06	Vert(TL)	n/a	-	n/a	999		
BCLL	0.0*	Rep Stress Incr	YES	WB	0.00	Horiz(TL)	0.00	3	n/a	n/a		
BCDL	10.0	Code	IRC2015/TPI2014	Matrix-P							Weight: 11 lb	FT = 20%

LUMBER

TOP CHORD 2x4 SP No.1
BOT CHORD 2x4 SP No.1

BRACING

TOP CHORD Structural wood sheathing directly applied or 3-11-8 oc purlins.
BOT CHORD Rigid ceiling directly applied or 10-0-0 oc bracing.

REACTIONS (lb/size) 1=120/3-10-12, 3=120/3-10-12
Max Horiz 1=16 (LC 10)
Max Uplift 1=11 (LC 11), 3=11 (LC 11)

FORCES (lb) - Maximum Compression/Maximum Tension

TOP CHORD 1-2=-101/33, 2-3=-101/33
BOT CHORD 1-3=-7/67

NOTES

- Unbalanced roof live loads have been considered for this design.
- Wind: ASCE 7-10; Vult=115mph (3-second gust)
Vasd=91mph; TC DL=6.0psf; BC DL=6.0psf; h=30ft;
B=20ft; L=20ft; eave=4ft; Cat. II; Exp B; Enclosed;
MWFRS (directional) and C-C Exterior (2) zone;
cantilever left and right exposed; end vertical left and right exposed; C-C for members and forces & MWFRS for reactions shown; Lumber DOL=1.60 plate grip DOL=1.60
- Truss designed for wind loads in the plane of the truss only. For studs exposed to wind (normal to the face), see Standard Industry Gable End Details as applicable, or consult qualified building designer as per ANSI/TPI 1.
- Gable requires continuous bottom chord bearing.
- Gable studs spaced at 2-0-0 oc.
- * This truss has been designed for a live load of 20.0psf on the bottom chord in all areas where a rectangle 3-06-00 tall by 2-00-00 wide will fit between the bottom chord and any other members.

- Provide mechanical connection (by others) of truss to bearing plate capable of withstanding 11 lb uplift at joint 1 and 11 lb uplift at joint 3.

LOAD CASE(S) Standard



September 21, 2021

WARNING - Verify design parameters and READ NOTES ON THIS AND INCLUDED MITEK REFERENCE PAGE MII-7473 rev. 5/19/2020 BEFORE USE.

Design valid for use only with MiTek® connectors. This design is based only upon parameters shown, and is for an individual building component, not a truss system. Before use, the building designer must verify the applicability of design parameters and properly incorporate this design into the overall building design. Bracing indicated is to prevent buckling of individual truss web and/or chord members only. Additional temporary and permanent bracing is always required for stability and to prevent collapse with possible personal injury and property damage. For general guidance regarding the fabrication, storage, delivery, erection and bracing of trusses and truss systems, see **ANSI/TPI1 Quality Criteria, DSB-89 and BCSI Building Component**

Safety Information available from Truss Plate Institute, 2670 Crain Highway, Suite 203 Waldorf, MD 20601

ENGINEERING BY
TRENCO
A MiTek Affiliate

818 Soundside Road
Edenton, NC 27932

Symbols

PLATE LOCATION AND ORIENTATION



Center plate on joint unless x, y offsets are indicated. Dimensions are in ft-in-sixteenths. Apply plates to both sides of truss and fully embed teeth.



For 4 x 2 orientation, locate plates 0- 1/16" from outside edge of truss.



This symbol indicates the required direction of slots in connector plates.

* Plate location details available in **MITek 20/20 software** or upon request.

PLATE SIZE

4 X 4

The first dimension is the plate width measured perpendicular to slots. Second dimension is the length parallel to slots.

LATERAL BRACING LOCATION



Indicated by symbol shown and/or by text in the bracing section of the output. Use T or I bracing if indicated.

BEARING



Indicates location where bearings (supports) occur. Icons vary but reaction section indicates joint number where bearings occur. Min size shown is for crushing only.

Industry Standards:

ANSI/TFP 1: National Design Specification for Metal Plate Connected Wood Truss Construction.
DSB-89: Design Standard for Bracing, Building Component Safety Information, Guide to Good Practice for Handling, Installing & Bracing of Metal Plate Connected Wood Trusses.

Numbering System

6-4-8
dimensions shown in ft-in-sixteenths
(Drawings not to scale)



JOINTS ARE GENERALLY NUMBERED/LETTERED CLOCKWISE AROUND THE TRUSS STARTING AT THE JOINT FARTHEST TO THE LEFT.

CHORDS AND WEBS ARE IDENTIFIED BY END JOINT NUMBERS/LETTERS.

PRODUCT CODE APPROVALS

ICC-ES Reports:

ESR-1311, ESR-1352, ESR1988
ER-3907, ESR-2362, ESR-1397, ESR-3282

Trusses are designed for wind loads in the plane of the truss unless otherwise shown.

Lumber design values are in accordance with ANSI/TFP 1 section 6.3 These truss designs rely on lumber values established by others.

© 2012 MITteK® All Rights Reserved



MITek Engineering Reference Sheet: MII-7473 rev. 5/19/2020



General Safety Notes

Failure to Follow Could Cause Property Damage or Personal Injury

1. Additional stability bracing for truss system, e.g. diagonal or X-bracing, is always required. See BCSI.
2. Truss bracing must be designed by an engineer. For wide truss spacing, individual lateral braces themselves may require bracing, or alternative Tor I bracing should be considered.
3. Never exceed the design loading shown and never stack materials on inadequately braced trusses.
4. Provide copies of this truss design to the building designer, erection supervisor, property owner and all other interested parties.
5. Cut members to bear tightly against each other.
6. Place plates on each face of truss at each joint and embed fully. Knots and wane at joint locations are regulated by ANSI/TFP 1.
7. Design assumes trusses will be suitably protected from the environment in accord with ANSI/TFP 1.
8. Unless otherwise noted, moisture content of lumber shall not exceed 19% at time of fabrication.
9. Unless expressly noted, this design is not applicable for use with fire retardant, preservative treated, or green lumber.
10. Camber is a non-structural consideration and is the responsibility of truss fabricator. General practice is to camber for dead load deflection.
11. Plate type, size, orientation and location dimensions indicated are minimum plating requirements.
12. Lumber used shall be of the species and size, and in all respects, equal to or better than that specified.
13. Top chords must be sheathed or purlins provided at spacing indicated on design.
14. Bottom chords require lateral bracing at 10 ft. spacing, or less, if no ceiling is installed, unless otherwise noted.
15. Connections not shown are the responsibility of others.
16. Do not cut or alter truss member or plate without prior approval of an engineer.
17. Install and load vertically unless indicated otherwise.
18. Use of green or treated lumber may pose unacceptable environmental, health or performance risks. Consult with project engineer before use.
19. Review all portions of this design (front, back, words and pictures) before use. Rewriting pictures alone is not sufficient.
20. Design assumes manufacture in accordance with ANSI/TFP 1 Quality Criteria.
21. The design does not take into account any dynamic or other loads other than those expressly stated.