

## Harnett County Department of Public Health Improvement Permit

A building permit cannot be issued with only an Improvement Permit

ISSUED TO: Family Building Company LLC PROPERTY LOCATION: SR 1418 Raven Rd  
 NEW  REPAIR  EXPANSION  SUBDIVISION: Captains Landing LOT # 38  
 Site Improvements required prior to Construction Authorization Issuance:  
 Type of Structure: SFD  
 Proposed Wastewater System Type: 25% REDUCTION  
 Projected Daily Flow: 360 GPD  
 Number of bedrooms: 3 Number of Occupants: 6 max  
 Basement  Yes  No  
 Pump Required:  Yes  No  May be required based on final location and elevations of facilities  
 Type of Water Supply:  Community  Public  Well Distance from well \_\_\_\_\_ feet  
 Permit conditions: \_\_\_\_\_ Permit valid for:  Five years  No expiration

Authorized State Agent: James E. Mashant ID: 2248 Date: 10-6-22 SEE ATTACHED SITE SKETCH  
 The issuance of this permit by the Health Department in no way guarantees the issuance of other permits. The permit holder is responsible for checking with appropriate governing bodies in meeting their requirements. This site is subject to revocation if the site plan, plat, or the intended use changes. The Improvement Permit shall not be affected by a change in ownership of the site. This permit is subject to compliance with the provisions of the Laws and Rules for Sewage Treatment and Disposal and to conditions of this permit.

### Construction Authorization (Required for Building Permit)

The construction and installation requirements of Rules 1950, 1952, 1954, 1955, 1956, 1957, 1958, and 1959 are incorporated by references into this permit and shall be met. Systems shall be installed in accordance with the attached system layout.

ISSUED TO: Family Building Company LLC PROPERTY LOCATION: SR 1418 Raven Rd  
 SUBDIVISION: Captains Landing LOT # 38  
 Facility Type: \_\_\_\_\_  New  Expansion  Repair  
 Basement?  Yes  No Basement Fixtures?  Yes  No  
 Type of Wastewater System\*\*: 25% REDUCTION (Initial) Wastewater Flow: 360 GPD  
 (See note below, if applicable   
Repair Exempt (Repair)  
 Installation Requirements/Conditions  
 Septic Tank Size 1000 gallons Number of trenches 2  
 Exact length of each trench 120 feet Trench Spacing: 7 Feet on Center  
 Pump Tank Size \_\_\_\_\_ gallons Trenches shall be installed on contour at a map  
 Maximum Trench Depth of: 20-718 inches Soil Cover: 6 inches  
 (Trench bottoms shall be level to  $\pm 1/4"$  (Maximum soil cover shall not exceed 36" above the trench bottom)  
 in all directions)  
 Pump Requirements: \_\_\_\_\_ ft. TDH vs. \_\_\_\_\_ GPM Aggregate Depth: 6 inches below pipe  
2 inches above pipe  
 Conditions: START DOWNS WILL BE NEEDED 12 inches total

**WATER LINES (INCLUDING IRRIGATION) MUST BE 10FT. FROM ANY PART OF SEPTIC SYSTEM OR REPAIR AREA.  
 NO UTILITIES ALLOWED IN INITIAL OR REPAIR DRAIN FIELD AREA.**

**\*\*If applicable: I understand the system type specified is different from the type specified on the application. I accept the specifications of this permit.**

Owner/Legal Representative Signature: \_\_\_\_\_ Date: \_\_\_\_\_

This Construction Authorization is subject to revocation if the site plan, plat, or the intended use changes. The Construction Authorization shall not be transferred when there is a change in ownership of the site. This Construction Authorization is subject to compliance with the provisions of the Laws and Rules for Sewage Treatment and Disposal and to the conditions of this permit. SEE ATTACHED SITE SKETCH

Authorized State Agent: James E. Mashant ID: 2248 Date: 10-6-22  
 Construction Authorization Expiration Date: 10-6-27

Application # SFD 2209-0060

Harnett County Department of Public Health  
Site Sketch

793 JASMINE RD

Property Location: SR 1418 Raven RD

Issued To: Family Building Company Subdivision Captains Landing Lot # 38

Authorized State Agent: James E. Marshall Date: 10-6-22

\* STEP DOWNS WILL BE NEEDED

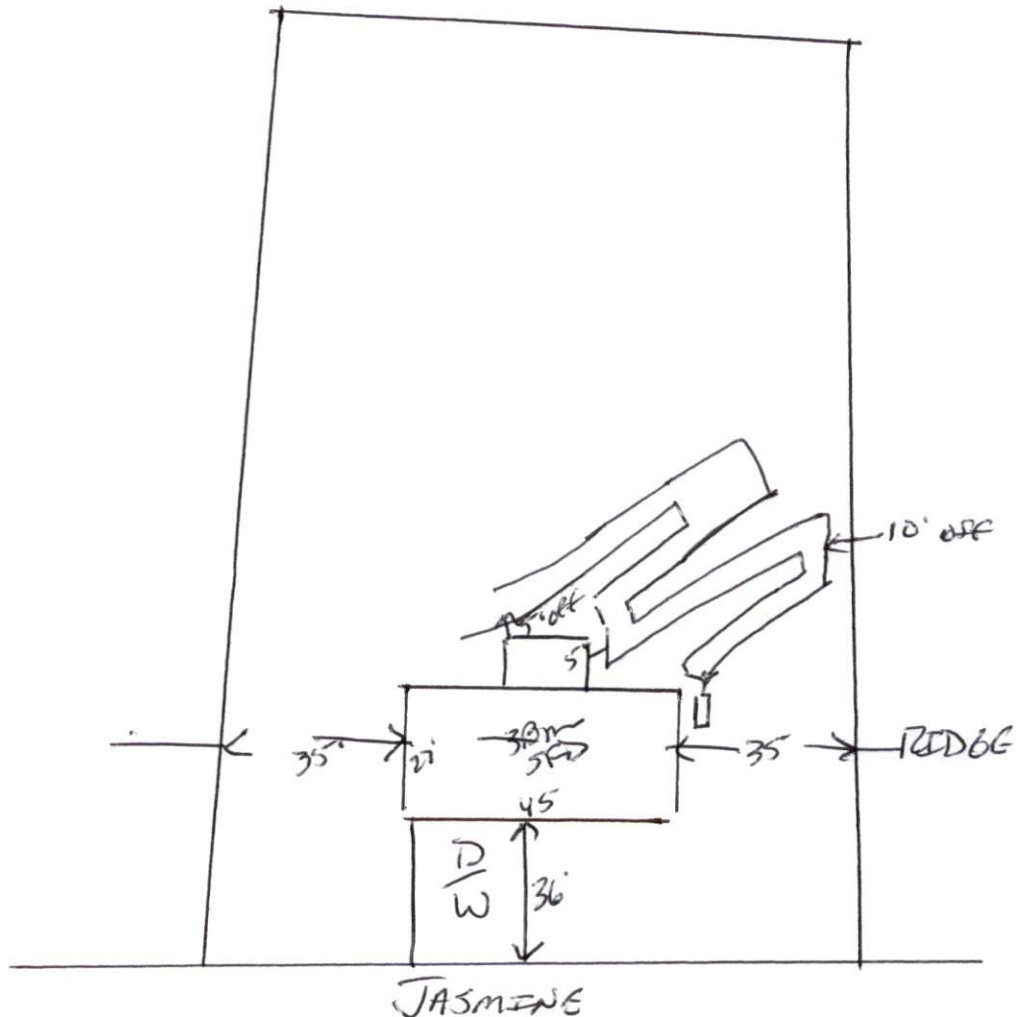

This drawing is for illustrative purposes only. System installation must meet all pertinent laws, rules, and regulations.