

VICINITY MAP (NTS)

NOTES:
 AREA BY COORDINATES
 NO HORIZONTAL CONTROL FOUND WITHIN 2000'
 THIS SURVEY DID NOT HAVE THE BENEFIT OF A TITLE REPORT AND
 IS SUBJECT TO MATTERS THAT IT MAY DISCLOSE
 PROPERTY SUBJECT TO BOTH ABOVE AND OR BELOW GROUND
 UTILITIES AND OR EASEMENTS
 THIS PROPERTY IS NOT LOCATED IN A FLOOD HAZARD AREA PER
 F.E.M.A. MAP # 3720068200J; EFF DATE 10/03/2006 ZONE X

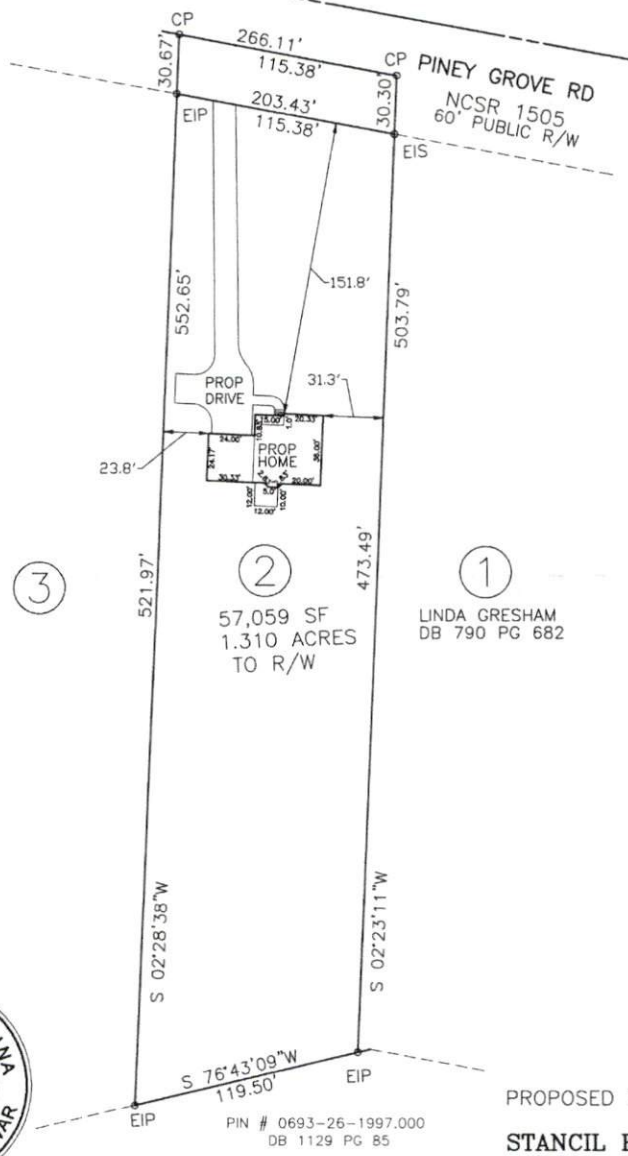
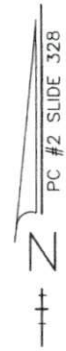

- LEGEND:
- EIP - EXISTING IRON PIPE
 - EIS - EXISTING IRON STAKE
 - ISS - IRON STAKE SET
 - CC - CONTROL CORNER
 - CP - COMPUTED POINT
 - PG - PAGE
 - CONC - CONCRETE
 - HVAC - HEAT/AIR UNIT
 - C/O = CLEAN OUT
 - WM - WATER METER
 - TP - TELEPHONE PEDESTAL
 - CTV - CABLE TV PEDESTAL
 - R/W - RIGHT OF WAY
 - DB - DEED BOOK
 - BM - BOOK OF MAPS
 - GM - GAS METER
 - NTS - NOT TO SCALE
 - PC - PLAT CABINET

③

②
 57,059 SF
 1.310 ACRES
 TO R/W

①

LINDA GRESHAM
 DB 790 PG 682



I, BENTON W. DEWAR CERTIFY THAT THIS PLAT WAS DRAWN UNDER
 MY SUPERVISION FROM AN ACTUAL SURVEY MADE UNDER MY
 SUPERVISION; THAT THE RATIO OF PRECISION IS 1:10,000+
 THAT THE BOUNDARIES NOT SURVEYED ARE SHOWN AS BROKEN LINES
 PLOTTED FROM INFORMATION FOUND IN BOOK 986
 PAGE 328; THAT THIS PLAT DOES NOT MEET SIZE REQUIREMENTS
 FOR RECORDING IN THE REGISTER OF DEEDS, PER G.S. 47-30 AS AMENDED.
 I SIGN AND SEAL THIS 26th DAY OF AUGUST 2022.

PROFESSIONAL LAND SURVEYOR L-3040
 THIS PLAT MAY NOT BE A CERTIFIED SURVEY AND HAS
 NOT BEEN REVIEWED BY A LOCAL GOVERNMENT AGENCY FOR
 COMPLIANCE WITH ANY APPLICABLE LAND DEVELOPMENT REGULATIONS
 AND HAS NOT BEEN REVIEWED FOR COMPLIANCE WITH
 RECORDING REQUIREMENTS FOR PLATS.

PROPOSED PLOT PLAN FOR:

STANCIL BUILDERS, INC

LOT 2 PLAT CABINET #2 SLIDE 328
 DEED BOOK 986 PAGE 117
 PIN # 0693-17-8677.000
 BLACK RIVER TOWNSHIP
 HARNETT COUNTY - NORTH CAROLINA
 SCALE: 1" = 60' AUGUST 26, 2022



BENTON DEWAR & ASSOCIATES
 PROFESSIONAL LAND SURVEYOR
 5920 HONEYCUTT ROAD
 HOLLY SPRINGS, NC 27540
 (919)-552-9813

22-78L
 STANCIL\22\700