

# Residence for

Garman Homes  
 Lot 0095 Serenity  
 Fuquay Varina, North Carolina



This document is property of Garman Homes Inc, and was prepared for their use only. The plans, elevations, illustrations, and other material contained within this set may not be reproduced, either in part or wholly, in any manner without the express written permission of Garman Homes, Inc. All right reserved and protected under federal law.

**Project Number**  
 Project Number  
**Plan Number**  
 FP-2034

## INDEX TO DRAWINGS

- COVER SHEET  
 1 FRONT & LEFT SIDE ELEVATIONS  
 2 REAR & RIGHT SIDE ELEVATIONS  
 3 FIRST & SECOND FLOOR PLANS  
 E FIRST & SECOND FLOOR ELECTRICAL PLANS  
 M FIRST & SECOND FLOOR MECHANICAL PLANS  
 P FIRST FLOOR PLUMBING PLAN  
 D CONSTRUCTION DETAILS

- S1 FOUNDATION PLAN & FIRST FLOOR FRAMING PLAN  
 S2 SECOND FLOOR FRAMING PLAN & ROOF FRAMING PLAN  
 S3 OPTIONAL SCREEN PORCH DETAILS  
 SD1 STRUCTURAL DETAILS  
 SD2 STRUCTURAL DETAILS  
 SD3 STRUCTURAL DETAILS  
 SPEC STRUCTURAL NOTES

## GENERAL NOTES

- ALL WORK TO BE DONE IN STRICT ACCORDANCE WITH NORTH CAROLINA STATE RESIDENTIAL BUILDING CODE, 2018 EDITION (HEREWITH SHOWN AS N.C.S.R.B.C.).
- DIMENSIONS SHOWN ON DRAWINGS GOVERN OVER SCALE.
- STUD WALL DESIGN SHALL CONFORM TO ALL N.C.S.R.B.C. REQUIREMENTS
- CONTRACTOR SHALL USE TEMPERED SAFETY GLASS IN ALL LOCATIONS AS REQUIRED BY N.C.S.R.B.C., 2018 EDITION, SECTION R308.4.
- ANY HABITABLE ROOM SHALL MEET ALL LIGHT/VENTILATION AND EGRESS AS REQUIRED BY N.C.S.R.B.C. 2018 EDITION, SECTIONS R-303.1 AND R-310.1.
- ALL EXTERIOR WALLS SHOWN ON FLOOR PLANS ARE 2X6 FRAME UNLESS NOTED OTHERWISE. ALL INTERIOR WALLS SHOWN ON FLOOR PLANS ARE 2X4 FRAME UNLESS NOTED OTHERWISE.
- ALL ANGLED WALLS SHOWN ON FLOOR PLANS ARE 45 UNLESS NOTED OTHERWISE.
- ALL WINDOWS SHALL HAVE A MINIMUM DPI RATING OF 25. BUILDER SHALL VERIFY WITH WINDOW MANUFACTURER THAT UNITS INSTALLED MEET THESE REQUIREMENTS AS PER N.C.S.R.B.C., 2018 EDITION, TABLE 301.2(4).
- ENERGY EFFICIENCY REQUIREMENTS FOR THE SPECIFIC CLIMATE ZONE WHERE STRUCTURE IS BEING BUILT SHALL BE IN ACCORDANCE WITH CHAPTER 11 OF THE N.C.S.R.B.C., 2018 EDITION, AS SHOWN IN SECTION N1101.2.

## RESIDENTIAL BUILDING CODE SUMMARY

- PLANS ARE DESIGNED TO THE 2018 N.C.S.R.B.C.
  - HOUSE IS DESIGNED FOR 115 MPH ULTIMATE DESIGN WIND SPEED (89 MPH NOMINAL DESIGN WIND SPEED), EXPOSURE B.
  - ANCHOR BOLTS SHALL BE MIN. 1/2" DIAMETER AND SHALL EXTEND 7" MIN. INTO MASONRY OR CONCRETE. BOLTS TO BE NO MORE THAN 6' O.C. AND WITHIN 12" FROM THE CORNER.
  - MEAN ROOF HEIGHT: 35'-0"
  - COMPONENT & CLADDING DESIGNED FOR THE FOLLOWING LOADS:
- | MEAN ROOF HGT: | UP TO 30'  | 30'-1" TO 35' | 35'-1" TO 40' | 40'-1" TO 45' |
|----------------|------------|---------------|---------------|---------------|
| ZONE 1         | 16.5,-18.0 | 17.3,-18.9    | 17.3,-18.9    | 17.3,-18.9    |
| ZONE 2         | 16.5,-21.0 | 17.3,-22.1    | 17.3,-22.1    | 17.3,-22.1    |
| ZONE 3         | 16.5,-21.0 | 17.3,-22.1    | 17.3,-22.1    | 17.3,-22.1    |
| ZONE 4         | 18.0,-19.5 | 18.9,-20.5    | 18.9,-20.5    | 18.9,-20.5    |
| ZONE 5         | 18.0,-24.1 | 18.9,-25.3    | 18.9,-25.3    | 18.9,-25.3    |
- MINIMUM VALUES FOR ENERGY COMPLIANCE: Zone 4
  - MAXIMUM GLAZING U-FACTOR: .35
  - INSULATING VALUES: CEILING: R-38 / WALLS: R-15 / FLOOR: R-19  
 SLABS: R-10. CODE REFERENCE: TABLE N1102.1

## AREA CALCULATIONS

| HEATED (SQ. FT.) |             | UNHEATED (SQ. FT.) |            | UNFINISHED (SQ. FT.) |     |
|------------------|-------------|--------------------|------------|----------------------|-----|
| BASEMENT:        | N/A         | GARAGE:            | 428        | 1ST FLOOR:           | N/A |
| 1ST FLOOR:       | 848         | FRONT PORCH:       | 81         | 2ND FLOOR:           | N/A |
| 2ND FLOOR:       | 1186        | DECK:              | N/A        | 3RD FLOOR:           | N/A |
| ATTIC:           | N/A         | SCREEN PORCH:      | 100        | TOTAL:               | N/A |
| GARAGE:          | N/A         |                    |            |                      |     |
| <b>TOTAL:</b>    | <b>2034</b> | <b>TOTAL:</b>      | <b>609</b> |                      |     |

  

| OVERALL DIMENSIONS |        |
|--------------------|--------|
| WIDTH:             | 33'-8" |
| DEPTH:             | 52'-6" |

## FOUNDATION VENTILATION CALCULATIONS

REFERENCE: N.C.S.R.B.C. 2018 EDITION SECTION R408)

NOT APPLICABLE WITH SLAB FOUNDATIONS

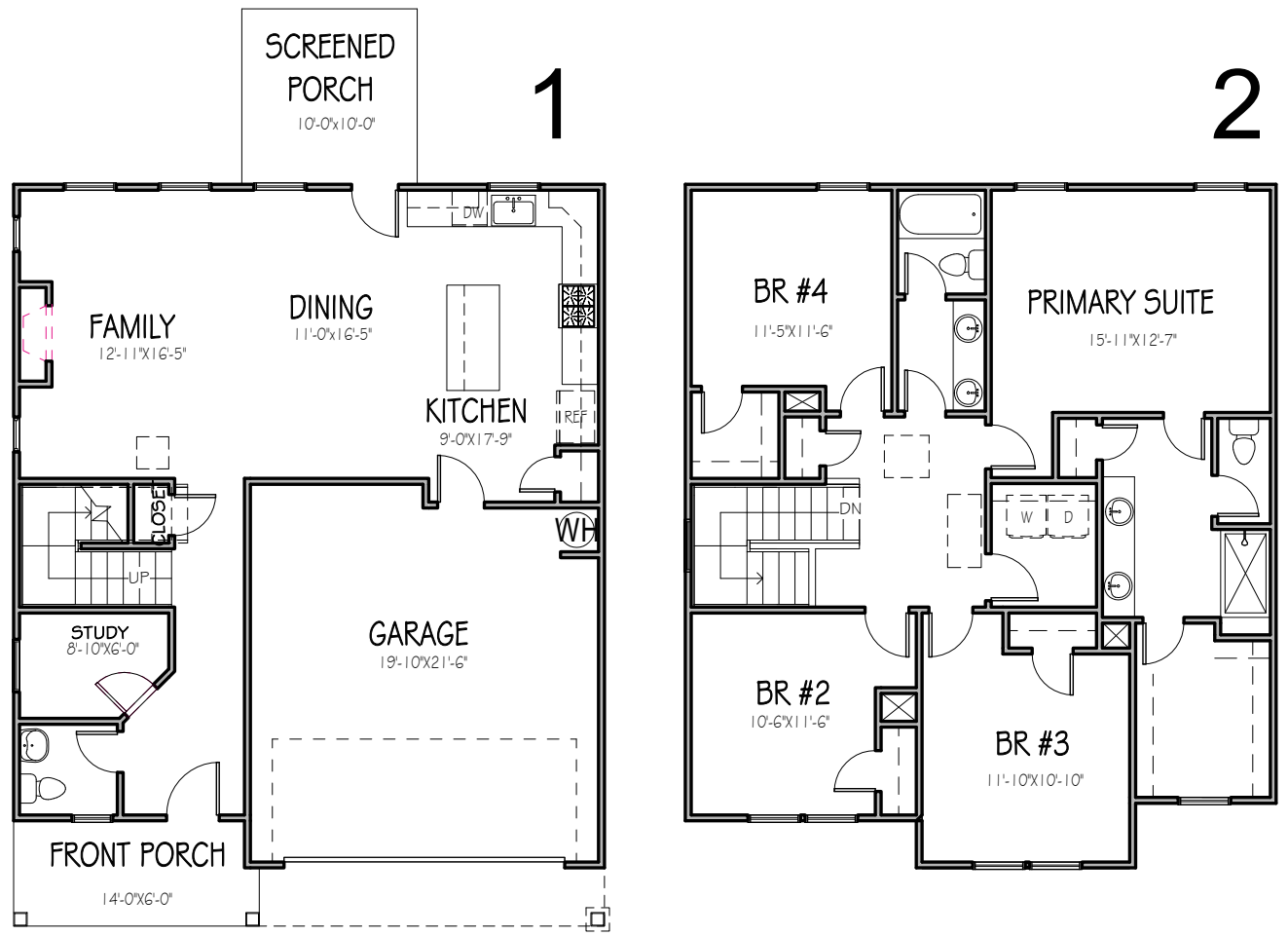

## MATERIALS LEGEND

|  |                      |  |                  |
|--|----------------------|--|------------------|
|  | EARTH/COMPACT FILL   |  | FINISH WOOD      |
|  | CONCRETE             |  | ROUGH WOOD       |
|  | BRICK                |  | BLOCKING         |
|  | CONCRETE BLOCK/STONE |  | PLYWOOD          |
|  | STEEL                |  | BATT INSULATION  |
|  | ALUMINUM             |  | RIGID INSULATION |

## ATTIC VENTILATION REQUIREMENTS

| NATURAL ROOF VENTILATION CALCULATIONS                           | MECHANICAL ROOF VENTILATION CALCULATIONS                        |
|---|---|
| 1357 SQ. FT. = 9.05 SQ. FT. VENT REQ'D<br>150                   | 1357 SQ. FT. = 4.53 SQ. FT. VENT REQ'D<br>300                   |
| BUILDER TO PROVIDE APPROPRIATE VENTILATING AS REQUIRED PER CODE | BUILDER TO PROVIDE APPROPRIATE VENTILATING AS REQUIRED PER CODE |

**WISTERIA**  
 SER ELEVATION A  
 LOT 0095 SERENITY

**Drawn By**  
 MMH  
**Checked By**  
 JM  
**Date Drawn**  
 3/18/20  
**Revision Date**  
 7/2/20  
 4/5/22

Sheet

**C**

THE PURPOSE OF THESE DRAWINGS IS TO SHOW THE INTENT OF THE DESIGN AND CONSTRUCTION OF THIS HOME. CONTRACTOR SHOULD VERIFY ALL CONDITIONS AND DIMENSIONS PRIOR TO CONSTRUCTION. ONCE A PERMIT HAS BEEN ISSUED, CONTRACTOR SHALL ASSUME ALL RESPONSIBILITY TO THE ACCURACY OF THE PLANS AND ANY CHANGES MADE DURING CONSTRUCTION.

This document is property of Garman Homes Inc, and was prepared for their use only. The plans, elevations, illustrations, and other material contained within this set may not be reproduced, either in part or wholly, in any manner without the express written permission of Garman Homes, Inc. All right reserved and protected under federal law.

|                       |                |
|-----------------------|----------------|
| <b>Project Number</b> | Project Number |
| <b>Plan Number</b>    | FP-2034        |



NOTE:  
PROVIDE RAILS @ PORCH ONLY IF REQUIRED BY CODE  
  
15' MIN. HGT. FOUNDATION FRONT GRADE TO FINISHED FRONT PORCH

**FRONT ELEVATION**

1/8" = 1'-0" NOTE - SLOPE ALL GRADES AWAY FROM HOUSE FOR POSITIVE DRAINAGE

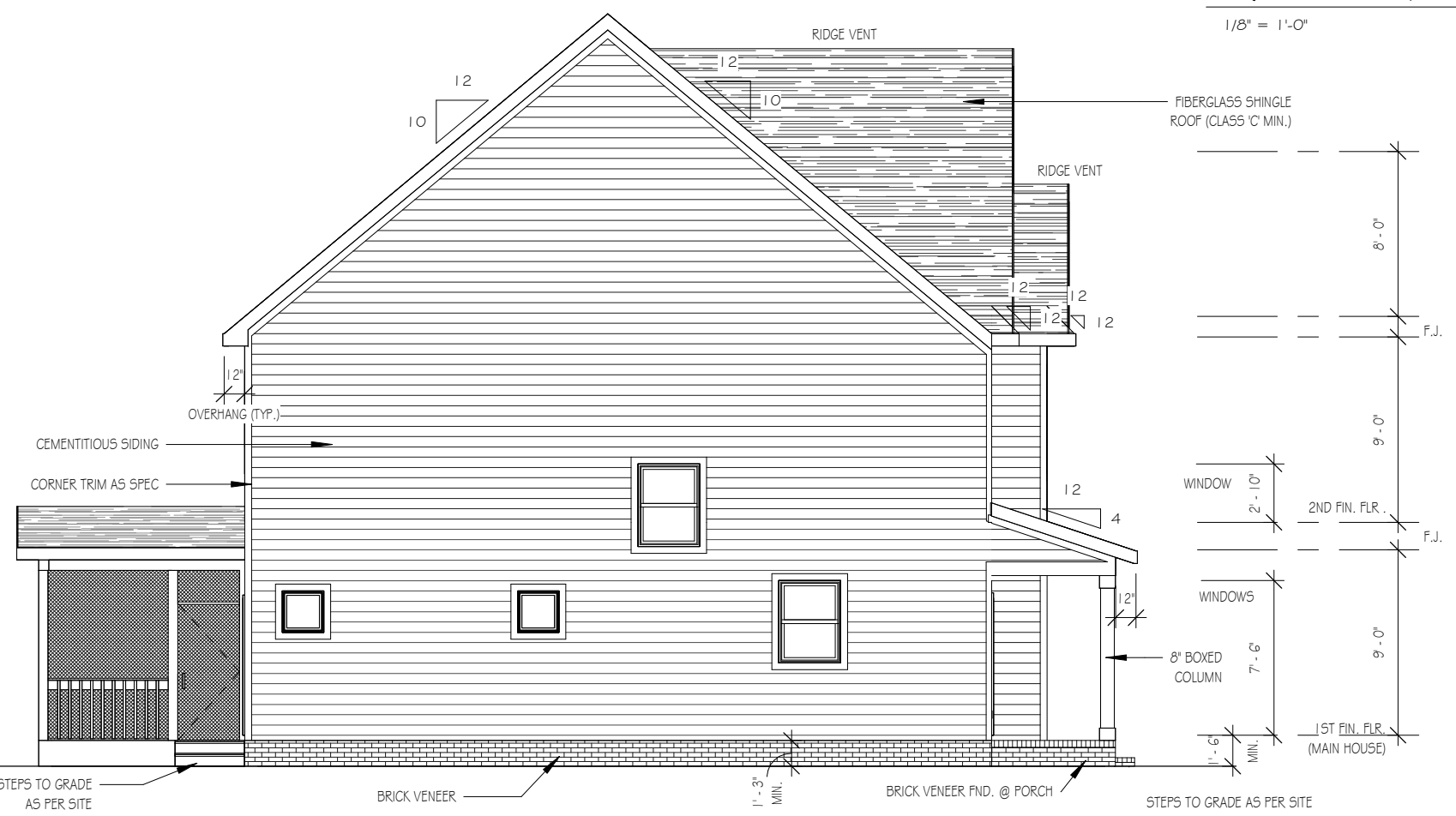

**LEFT SIDE ELEVATION**

1/8" = 1'-0" WINDOWS WITH CORNER LOTS ONLY

**WISTERIA**  
SER ELEVATION A  
LOT 0095 SERENITY

|                      |                  |
|----------------------|------------------|
| <b>Drawn By</b>      | MH               |
| <b>Checked By</b>    | CM               |
| <b>Date Drawn</b>    | 4/8/20           |
| <b>Revision Date</b> | 7/1/20<br>4/5/22 |

Sheet

THE PURPOSE OF THESE DRAWINGS IS TO SHOW THE INTENT OF THE DESIGN AND CONSTRUCTION OF THIS HOME. CONTRACTOR SHOULD VERIFY ALL CONDITIONS AND DIMENSIONS PRIOR TO CONSTRUCTION. ONCE A PERMIT HAS BEEN ISSUED, CONTRACTOR SHALL ASSUME ALL RESPONSIBILITY TO THE ACCURACY OF THE PLANS AND ANY CHANGES MADE DURING CONSTRUCTION.



This document is property of Garman Homes Inc, and was prepared for their use only. The plans, elevations, illustrations, and other material contained within this set may not be reproduced, either in part or wholly, in any manner without the express written permission of Garman Homes, Inc. All right reserved and protected under federal law.

|                       |                |
|-----------------------|----------------|
| <b>Project Number</b> | Project Number |
| <b>Plan Number</b>    | FP-2034        |



**REAR ELEVATION**

1/8" = 1'-0"

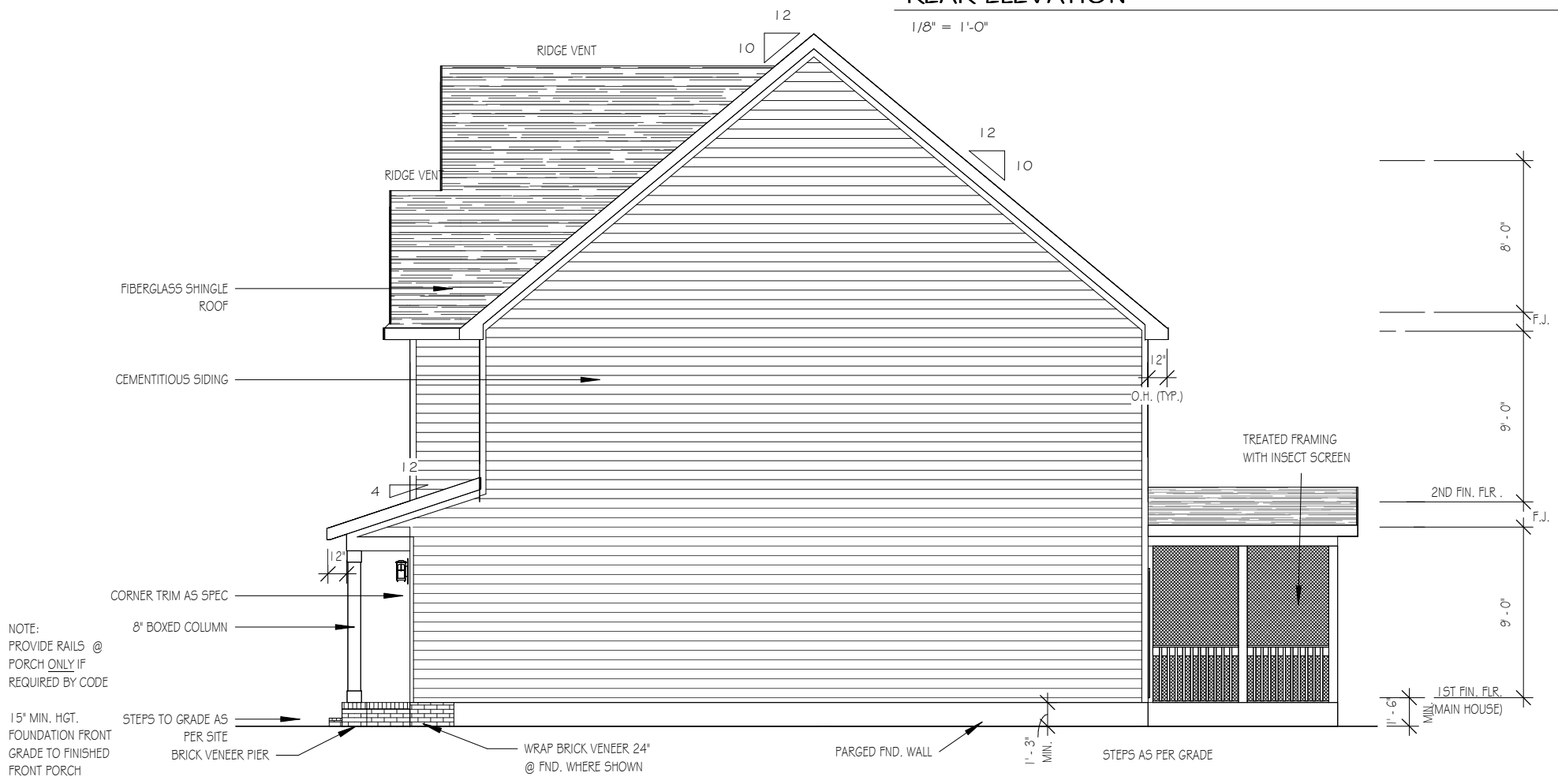

**RIGHT SIDE ELEVATION**

1/8" = 1'-0"

WINDOWS WITH CORNER LOTS ONLY

NOTE - SLOPE ALL GRADES AWAY FROM HOUSE FOR POSITIVE DRAINAGE

**WISTERIA**  
SER ELEVATION A  
LOT 0095 SERENITY

|                      |                  |
|----------------------|------------------|
| <b>Drawn By</b>      | MH               |
| <b>Checked By</b>    | CM               |
| <b>Date Drawn</b>    | 4/8/20           |
| <b>Revision Date</b> | 7/1/20<br>4/5/22 |

Sheet

THE PURPOSE OF THESE DRAWINGS IS TO SHOW THE INTENT OF THE DESIGN AND CONSTRUCTION OF THIS HOME. CONTRACTOR SHOULD VERIFY ALL CONDITIONS AND DIMENSIONS PRIOR TO CONSTRUCTION. ONCE A PERMIT HAS BEEN ISSUED, CONTRACTOR SHALL ASSUME ALL RESPONSIBILITY TO THE ACCURACY OF THE PLANS AND ANY CHANGES MADE DURING CONSTRUCTION.



This document is property of Garman Homes Inc. and was prepared for their use only. The plans, elevations, illustrations, and other material contained within this set may not be reproduced, either in part or wholly, in any manner without the express written permission of Garman Homes, Inc. All right reserved and protected under federal law.

|                       |                |
|-----------------------|----------------|
| <b>Project Number</b> | Project Number |
| <b>Plan Number</b>    | FP-2034        |

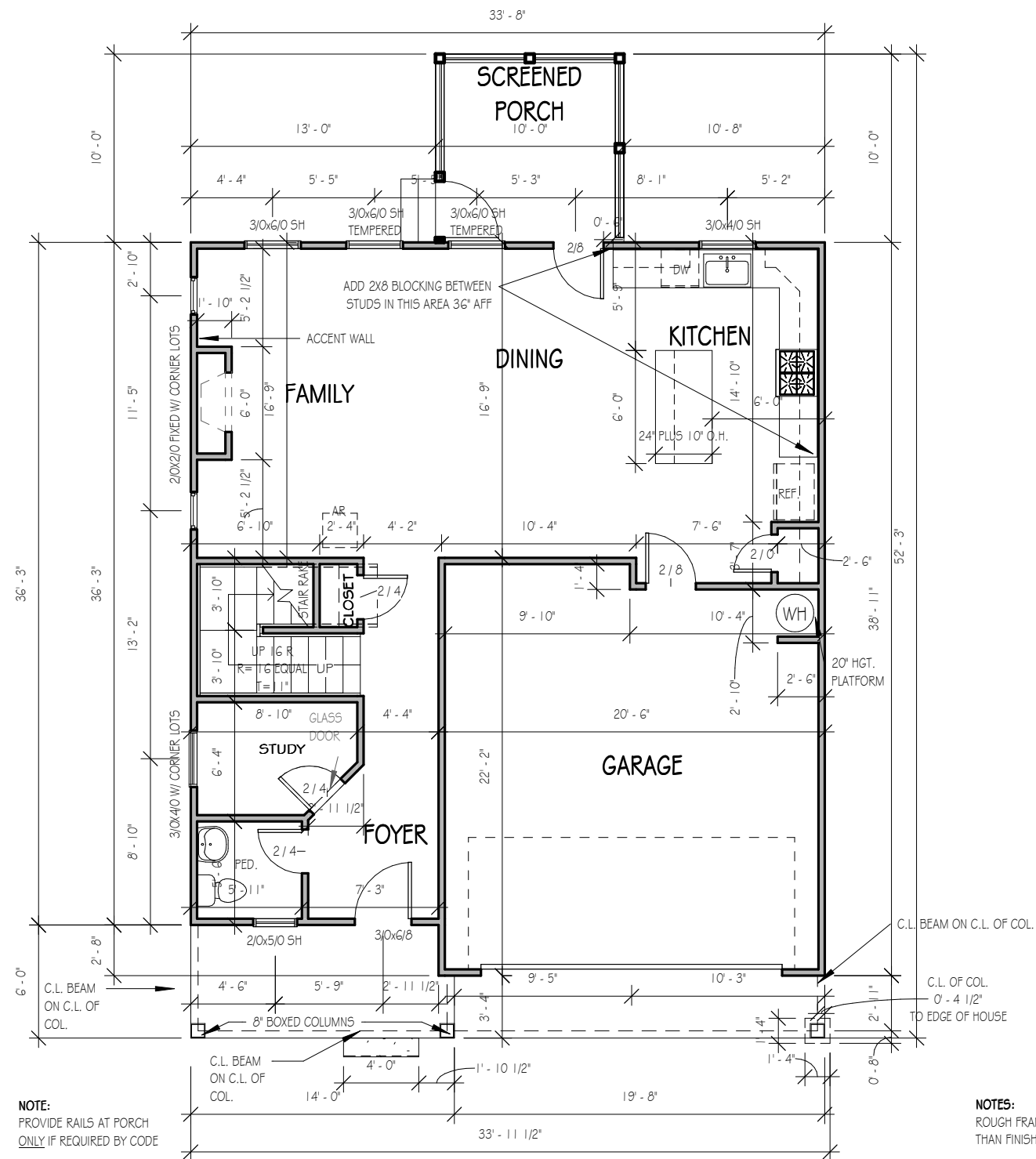

NOTE: PROVIDE RAILS AT PORCH ONLY IF REQUIRED BY CODE

NOTES: ROUGH FRAME ALL CASED OPENINGS 2" BIGGER THAN FINISHED OPENING CALLS FOR

ROUGH FRAME ALL WINDOW OPENINGS 1/2" LARGER THAN FINISHED WINDOW CALLS FOR, WHEN PAIRED WITH ANOTHER WINDOW THAT CALLS FOR DSP, ADD EXTRA TO OUTSIDE MEASUREMENT OF WINDOW

ALL EXTERIOR WALLS 2X4

TOP OF ALL WINDOWS SILLS SHALL BE 24" MINIMUM ABOVE THE FINISHED FLOOR OR A FALL PREVENTION DEVICE SHALL BE INSTALLED IN ACCORDANCE WITH SECTION R312.2.2 OF N.C.S.R.B.C., 2018 EDITION

**FIRST FLOOR**

1/8" = 1'-0"  
 9'-0" CLG. HGT. U.N.O.  
 SET WINDOWS @ 7'-6" U.N.O.  
 CASED OPENINGS 8'-0" TALL

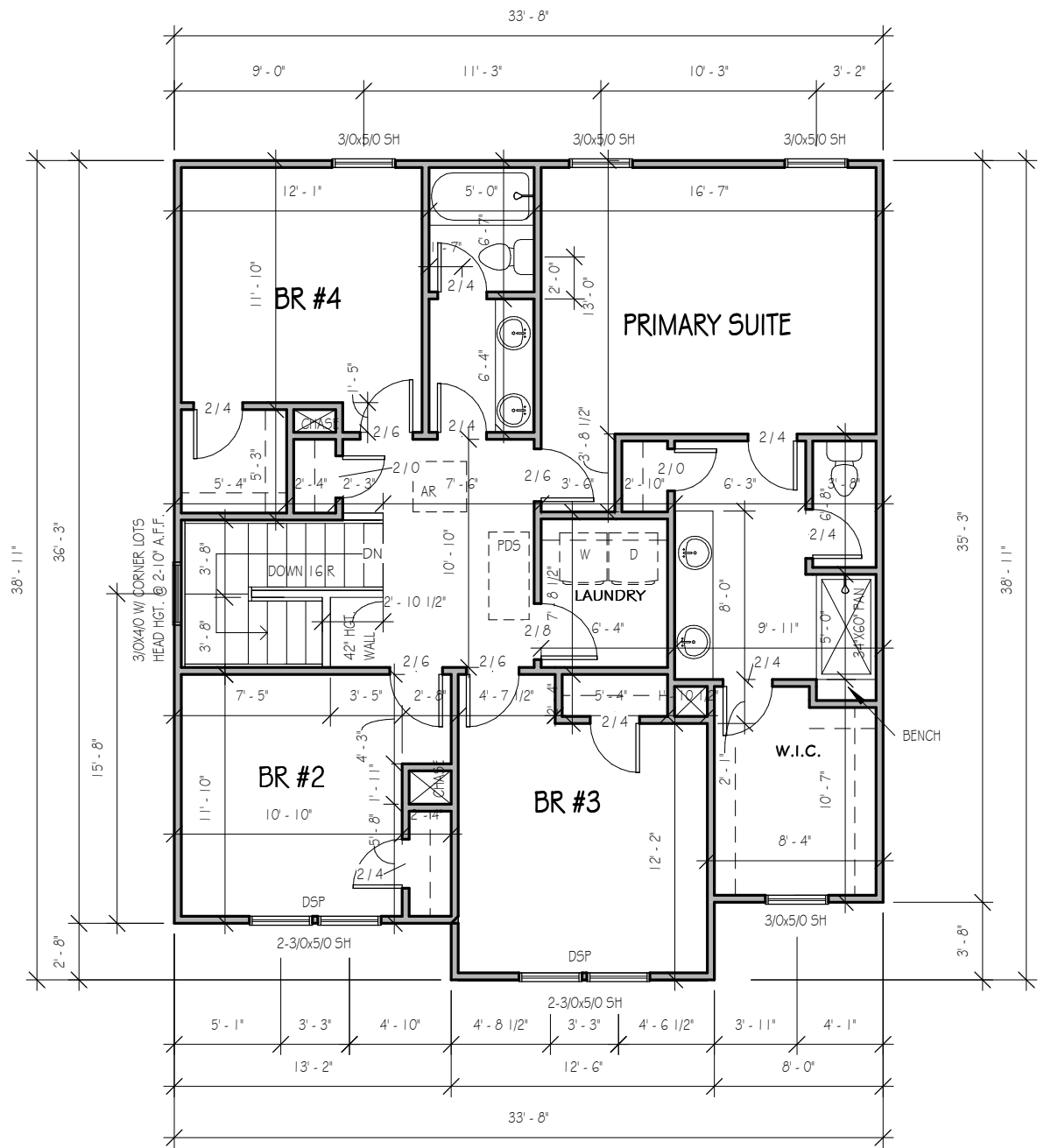

**SECOND FLOOR**

1/8" = 1'-0"  
 9'-0" CLG. HGT. U.N.O.  
 SET WINDOWS @ 7'-4" U.N.O.

**WISTERIA**  
 SER ELEVATION A  
 LOT 0095 SERENITY

|                      |        |
|----------------------|--------|
| <b>Drawn By</b>      | MH     |
| <b>Checked By</b>    | CM     |
| <b>Date Drawn</b>    | 4/8/20 |
| <b>Revision Date</b> | 7/1/20 |
|                      | 4/5/22 |

Sheet

THE PURPOSE OF THESE DRAWINGS IS TO SHOW THE INTENT OF THE DESIGN AND CONSTRUCTION OF THIS HOME. CONTRACTOR SHOULD VERIFY ALL CONDITIONS AND DIMENSIONS PRIOR TO CONSTRUCTION. ONCE A PERMIT HAS BEEN ISSUED, CONTRACTOR SHALL ASSUME ALL RESPONSIBILITY TO THE ACCURACY OF THE PLANS AND ANY CHANGES MADE DURING CONSTRUCTION.

This document is property of Garman Homes Inc, and was prepared for their use only. The plans, elevations, illustrations, and other material contained within this set may not be reproduced, either in part or wholly, in any manner without the express written permission of Garman Homes, Inc. All right reserved and protected under federal law.

**Project Number**  
Project Number  
**Plan Number**  
FP-2034

**WISTERIA**  
SER ELEVATION A  
LOT 0095 SERENITY

**Drawn By**  
MH  
**Checked By**  
CM  
**Date Drawn**  
4/8/20  
**Revision Date**  
7/1/20  
4/5/22

Sheet



**ELECTRICAL LEGEND**

- ⊕ - LIGHT FIXTURE
- ⊙ - FAUL LIGHT
- ⊕ - WATERPROOF OUTLET
- ⊠ - RECESSED LIGHTING
- ⊞ - SINGLE POLE SWITCH
- ⊞ - 2-WAY SWITCH
- ⊞ - 4-WAY SWITCH
- ⊞ - DIMMER SWITCH
- ⊞ - SMOKE DETECTOR
- ⊞ - FLOOD LIGHTS
- ⊞ - BIRTHDAY SPOTS
- ⊞ - DUPLEX RECEPTACLE (120V)
- ⊞ - 220 VOLT RECEPTACLE
- ⊞ - SWITCHED RECEPTACLE (TOP WIRE ONLY)
- ⊞ - GROUND FAULT CIRCUIT INTERRUPTOR

⊕ - GUS FAUL LIGHTS

⊞ - TRACK LIGHTS

⊞ - FLUORESCENT LIGHTING

- ⊙ - CABLE OUTLET
- ⊞ - TELEPHONE OUTLET
- ⊞ - COMPUTER DATA OUTLET
- ⊞ - BURGLAR ALARM
- ⊞ - INTERCOM

NOTE: ALL ELECTRICAL TO BE VERIFIED BY OWNER/BUILDER BEFORE ROUGH-IN.

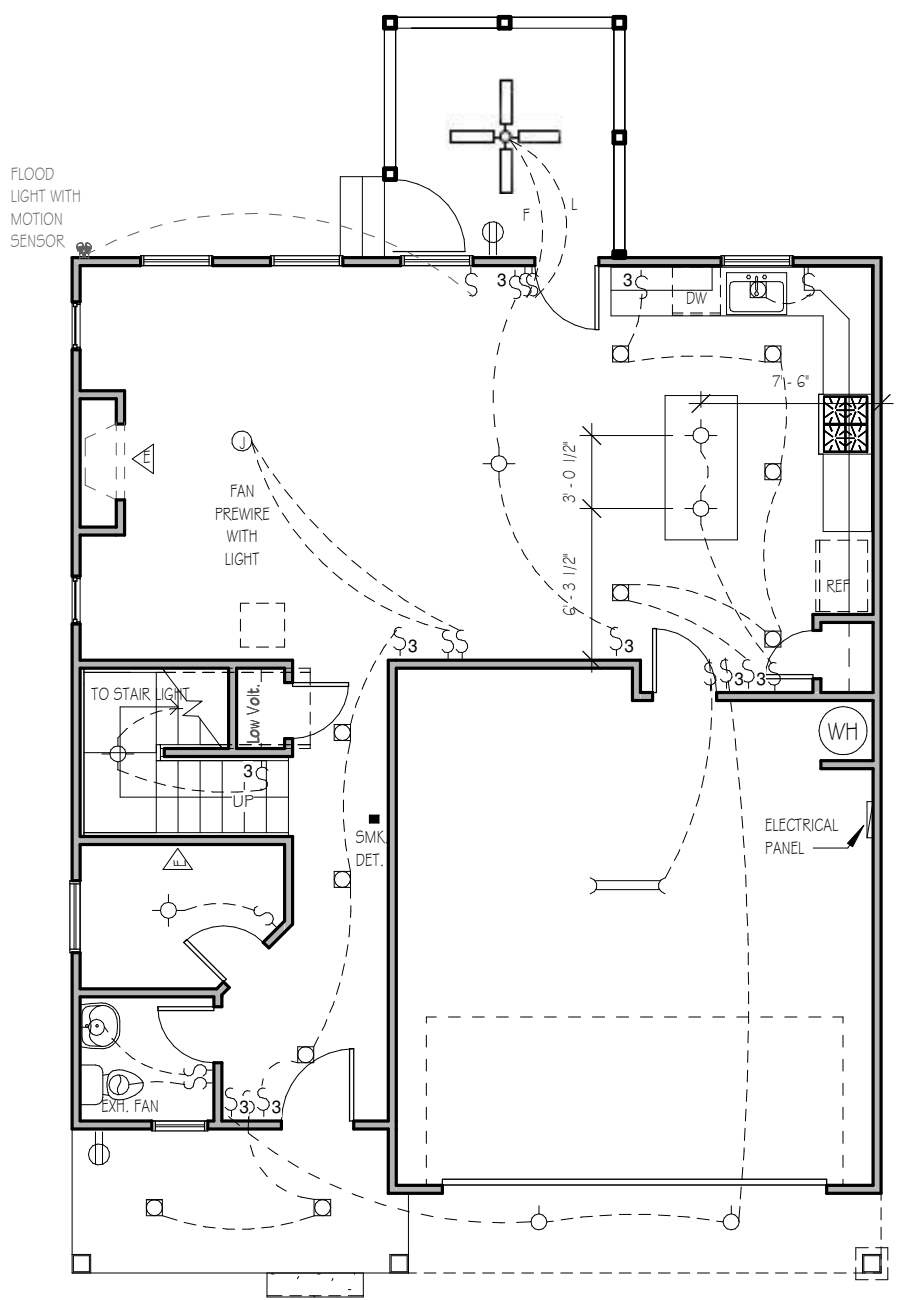

**FIRST FLOOR ELECTRICAL PLAN**

1/8" = 1'-0"

NOTE - ELECTRICAL RECEPTACLE AND SWITCH QUANTITIES AND LOCATIONS SHOWN ON PLAN ARE FOR ILLUSTRATION PURPOSES ONLY. ACTUAL NUMBER AND LOCATIONS SHALL BE FIELD DETERMINED AS PER CLIENT AND BUILDER EXCEPT WHERE CODE REQUIREMENTS APPLY.

\*\*NOTE: THREE ETHERNET OUTLETS IN THESE PREDETERMINED LOCATIONS ARE STANDARD. ANY ADDITIONAL OUTLETS ARE AN UPGRADE.

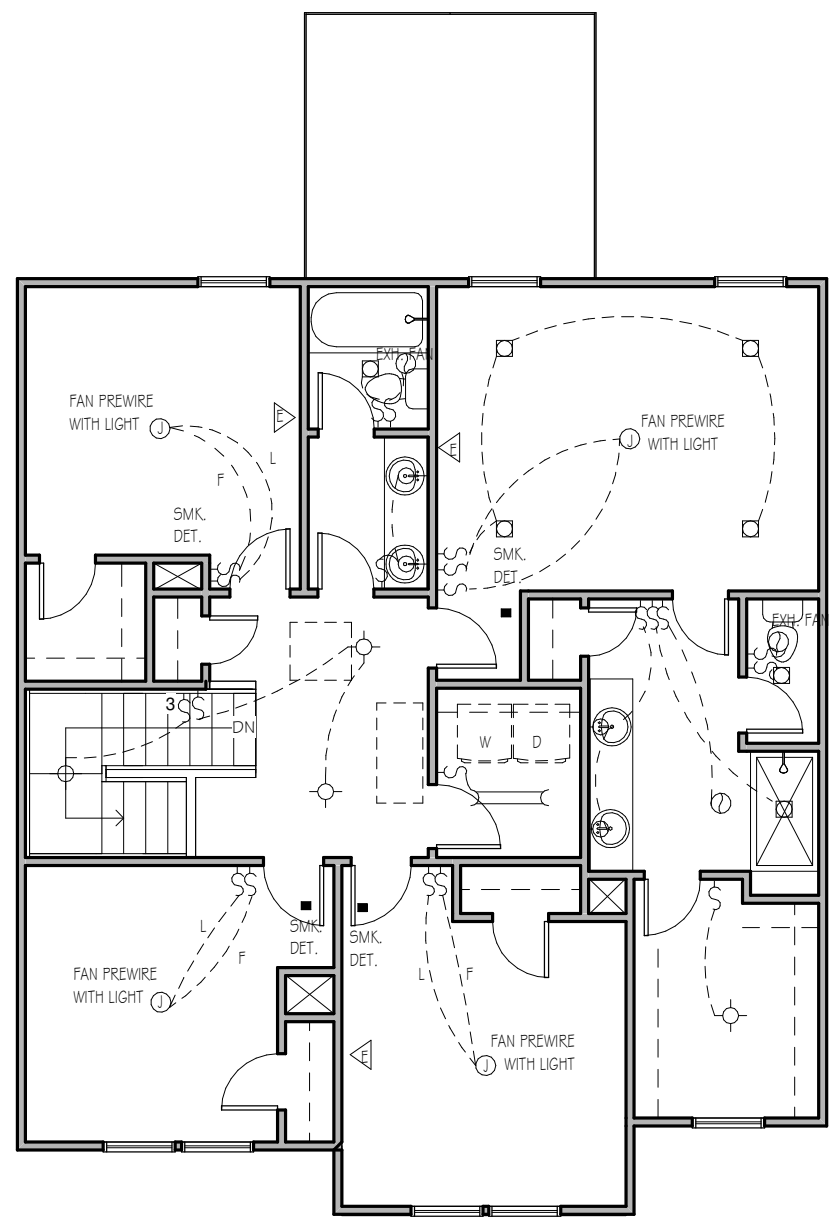

**SECOND FLOOR ELECTRICAL PLAN**

1/8" = 1'-0"

NOTE - ELECTRICAL RECEPTACLE AND SWITCH QUANTITIES AND LOCATIONS SHOWN ON PLAN ARE FOR ILLUSTRATION PURPOSES ONLY. ACTUAL NUMBER AND LOCATIONS SHALL BE FIELD DETERMINED AS PER CLIENT AND BUILDER EXCEPT WHERE CODE REQUIREMENTS APPLY.

THE PURPOSE OF THESE DRAWINGS IS TO SHOW THE INTENT OF THE DESIGN AND CONSTRUCTION OF THIS HOME. CONTRACTOR SHOULD VERIFY ALL CONDITIONS AND DIMENSIONS PRIOR TO CONSTRUCTION. ONCE A PERMIT HAS BEEN ISSUED, CONTRACTOR SHALL ASSUME ALL RESPONSIBILITY TO THE ACCURACY OF THE PLANS AND ANY CHANGES MADE DURING CONSTRUCTION.



This document is property of Garman Homes Inc, and was prepared for their use only. The plans, elevations, illustrations, and other material contained within this set may not be reproduced, either in part or wholly, in any manner without the express written permission of Garman Homes, Inc. All right reserved and protected under federal law.

|                       |                |
|-----------------------|----------------|
| <b>Project Number</b> | Project Number |
| <b>Plan Number</b>    | FP-2034        |

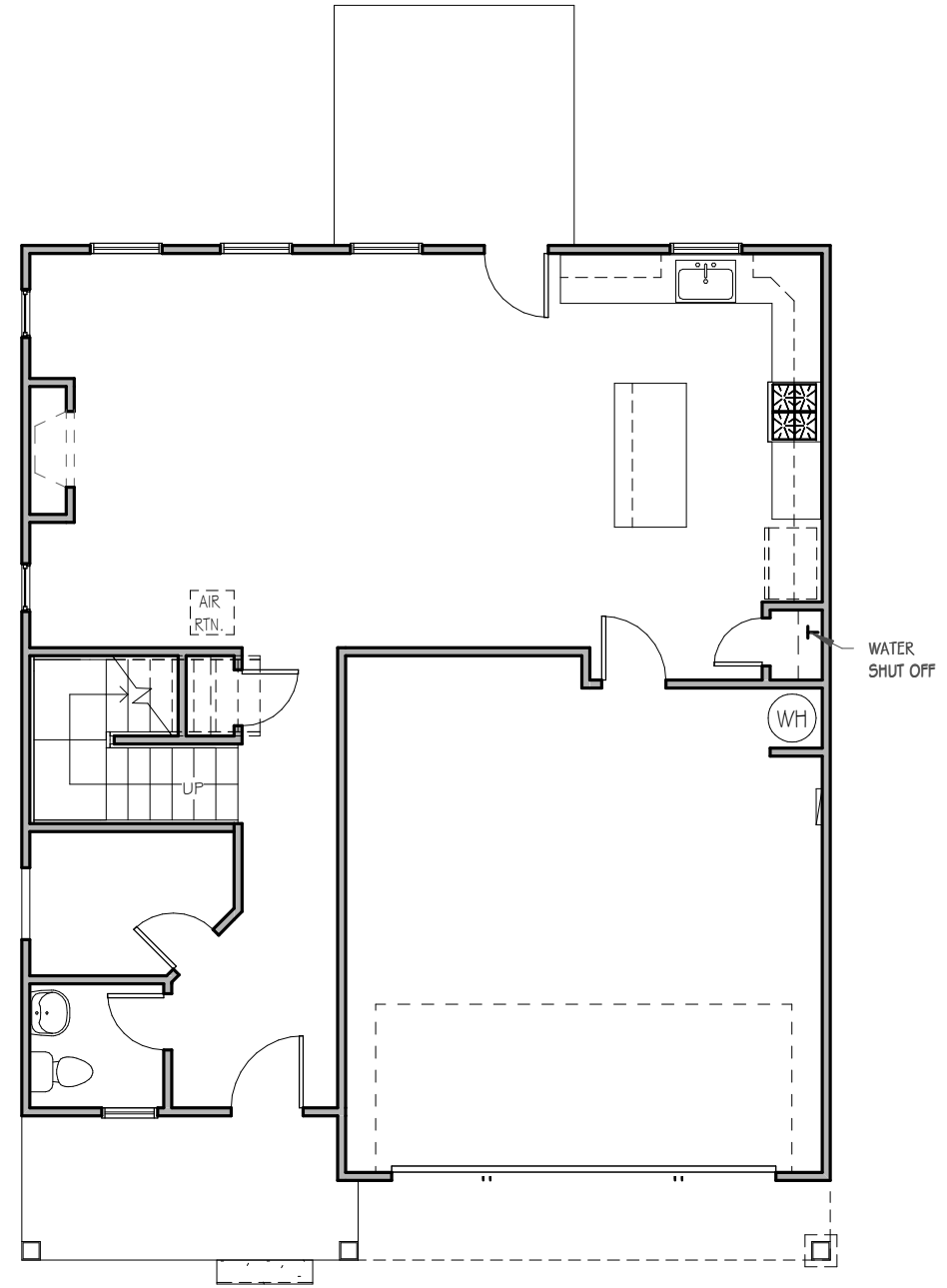

FIRST FLOOR MECHANICAL PLAN

1/8" = 1'-0"

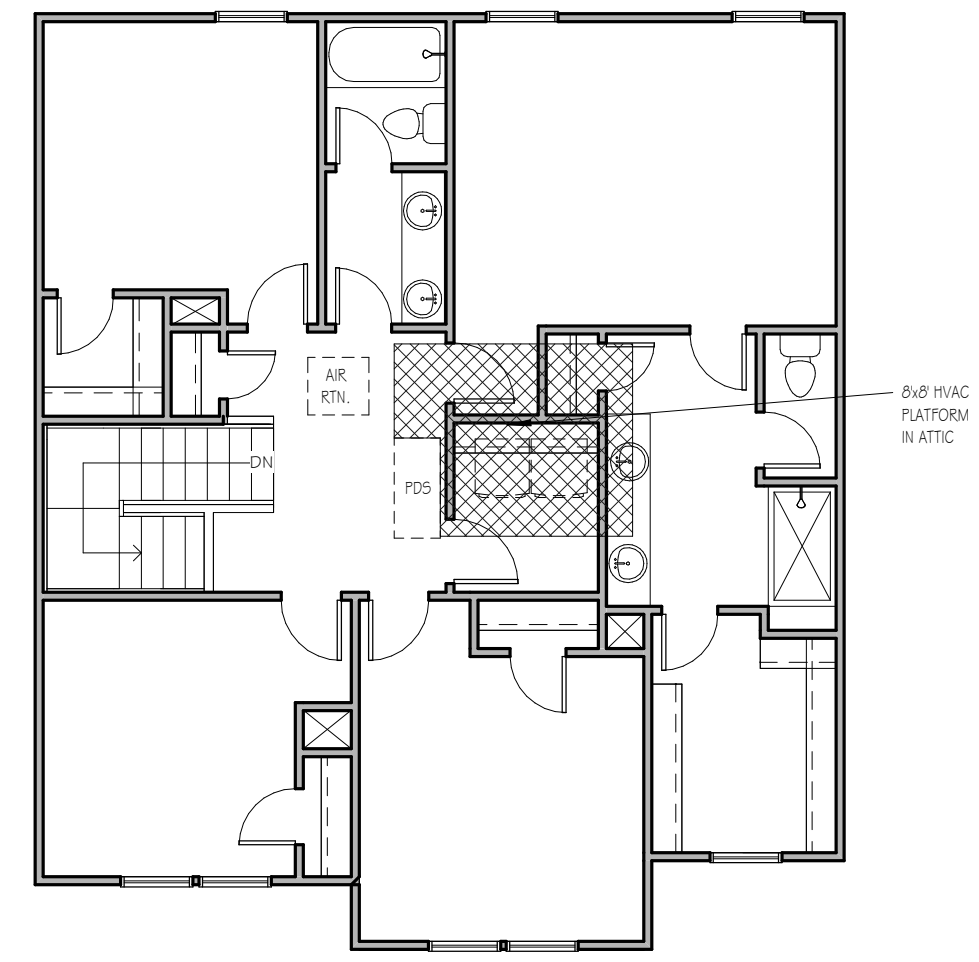

SECOND FLOOR MECHANICAL PLAN

1/8" = 1'-0"

**WISTERIA**  
SER ELEVATION A  
LOT 0095 SERENITY

|                      |        |
|----------------------|--------|
| <b>Drawn By</b>      | MH     |
| <b>Checked By</b>    | CM     |
| <b>Date Drawn</b>    | 4/8/20 |
| <b>Revision Date</b> | 7/1/20 |
|                      | 4/5/22 |

Sheet



THE PURPOSE OF THESE DRAWINGS IS TO SHOW THE INTENT OF THE DESIGN AND CONSTRUCTION OF THIS HOME. CONTRACTOR SHOULD VERIFY ALL CONDITIONS AND DIMENSIONS PRIOR TO CONSTRUCTION. ONCE A PERMIT HAS BEEN ISSUED, CONTRACTOR SHALL ASSUME ALL RESPONSIBILITY TO THE ACCURACY OF THE PLANS AND ANY CHANGES MADE DURING CONSTRUCTION.



This document is property of Garman Homes Inc, and was prepared for their use only. The plans, elevations, illustrations, and other material contained within this set may not be reproduced, either in part or wholly, in any manner without the express written permission of Garman Homes, Inc. All right reserved and protected under federal law.

|                       |                |
|-----------------------|----------------|
| <b>Project Number</b> | Project Number |
| <b>Plan Number</b>    | FP-2034        |

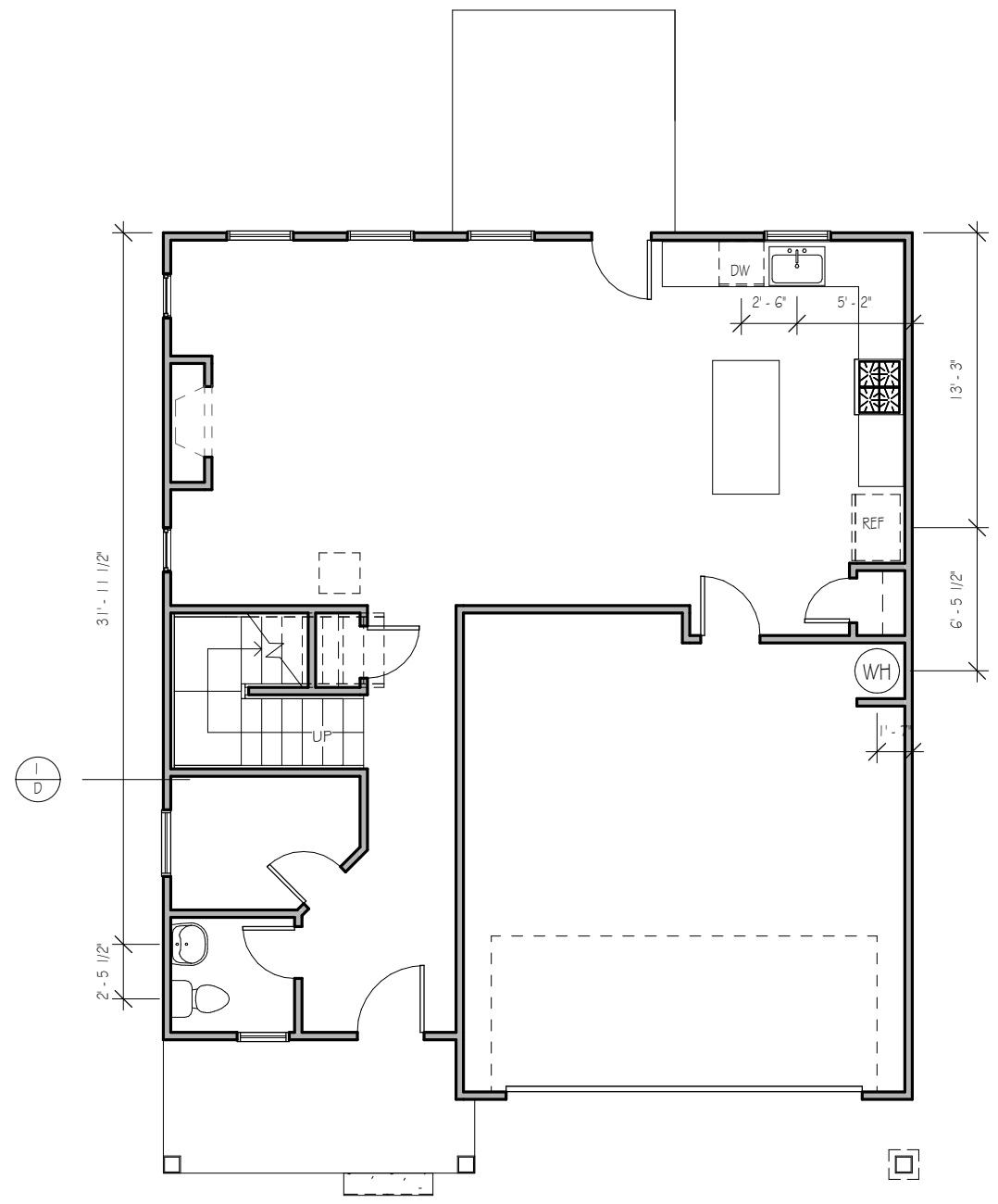

**FIRST FLOOR PLUMBING**

1/8" = 1'-0"

**WISTERIA**  
SER ELEVATION A  
LOT 0095 SERENITY

|                      |                  |
|----------------------|------------------|
| <b>Drawn By</b>      | MH               |
| <b>Checked By</b>    | CM               |
| <b>Date Drawn</b>    | 4/8/20           |
| <b>Revision Date</b> | 7/1/20<br>4/5/22 |

Sheet

**P**

THE PURPOSE OF THESE DRAWINGS IS TO SHOW THE INTENT OF THE DESIGN AND CONSTRUCTION OF THIS HOME. CONTRACTOR SHOULD VERIFY ALL CONDITIONS AND DIMENSIONS PRIOR TO CONSTRUCTION. ONCE A PERMIT HAS BEEN ISSUED, CONTRACTOR SHALL ASSUME ALL RESPONSIBILITY TO THE ACCURACY OF THE PLANS AND ANY CHANGES MADE DURING CONSTRUCTION.



This document is property of Garman Homes Inc, and was prepared for their use only. The plans, elevations, illustrations, and other material contained within this set may not be reproduced, either in part or wholly, in any manner without the express written permission of Garman Homes, Inc. All right reserved and protected under federal law.

Project Number \_\_\_\_\_  
 Project Number \_\_\_\_\_  
 Plan Number \_\_\_\_\_

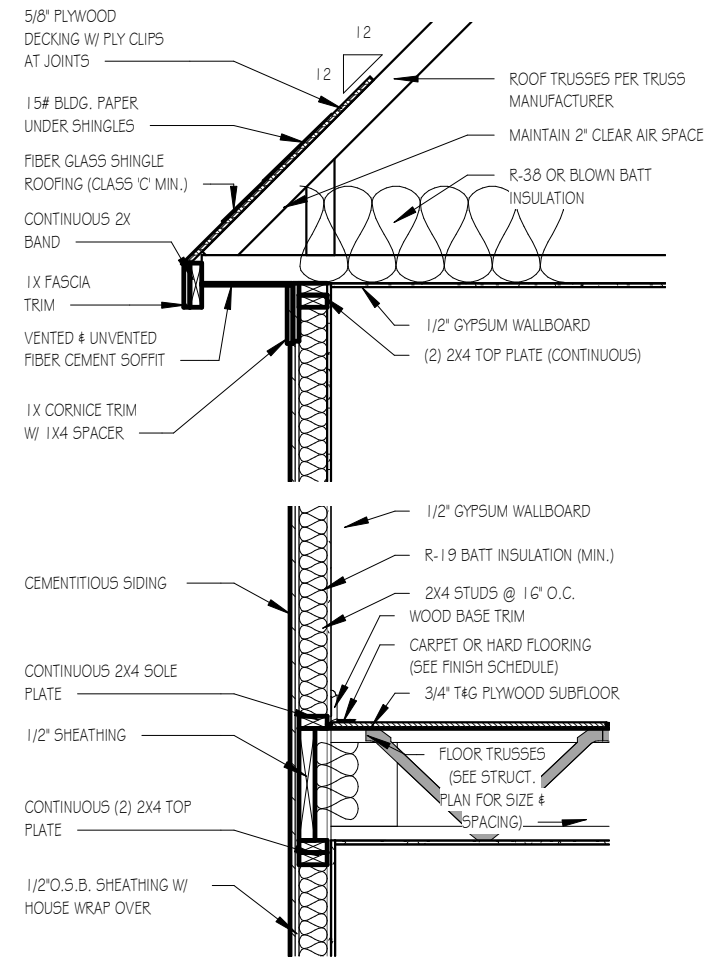

**TWO-STORY WALL SECTION**

1/2" = 1'-0"

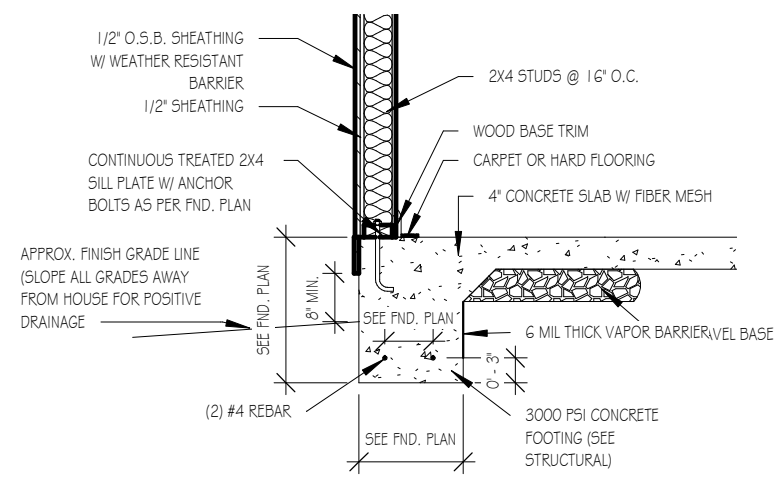

**FOUNDATION DETAIL - SLAB**

1/2" = 1'-0"

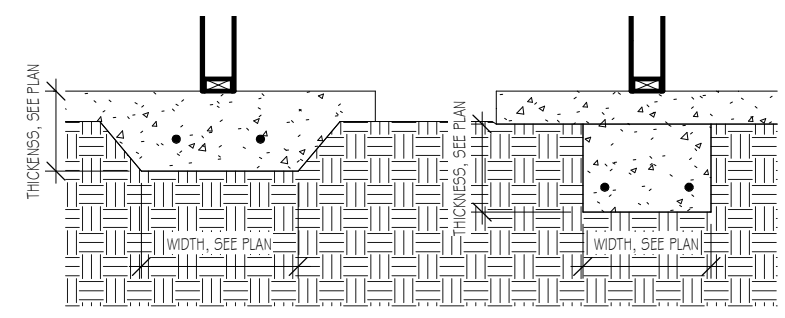

**LUG FOOTING**

1/2" = 1'-0"

**TYPICAL DETAIL SHEET**  
 SERENITY COLLECTION

Drawn By  
 MMH  
 Checked By  
 CM  
 Date Drawn  
 10/28/20  
 Revision Date  
 4/26/22

Sheet

**D**



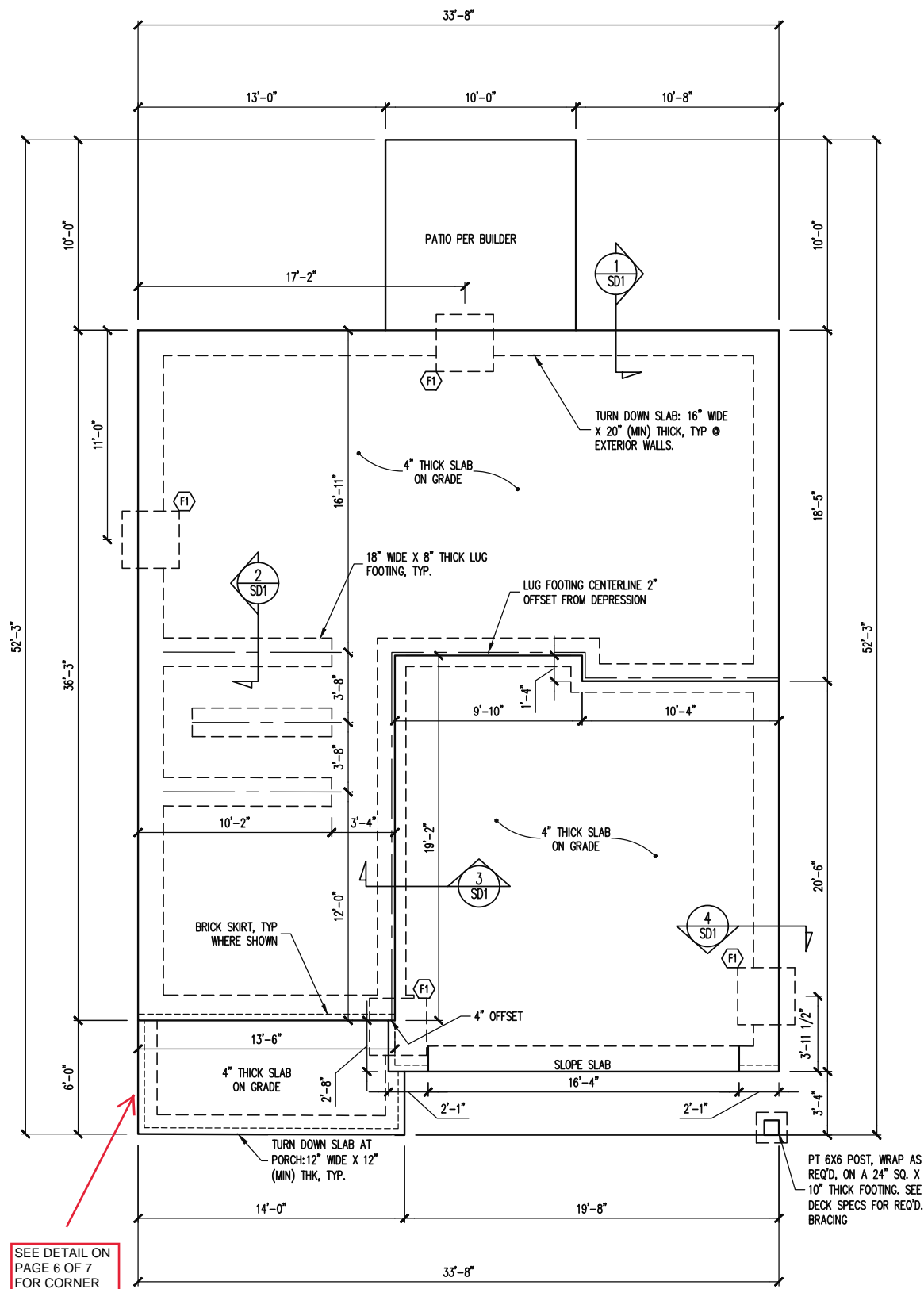

SEE DETAIL ON PAGE 6 OF 7 FOR CORNER LOT BRICK VENEER DETAIL

FOUNDATION PLAN  
ELEVATION A  
MONOSLAB OPTION

1/8" = 1'-0"

| FOUNDATION SCHEDULE |   |
|---------------------|---|
| F1                  | 12" THICK X 36" SQ. FOOTING   |
| NOTES:              |   |
| -                   | HEIGHT AND BACKFILL LIMITATIONS FOR FOUNDATION WALLS ARE TO BE GOVERNED BY THE NCSBC, LATEST EDITION. |

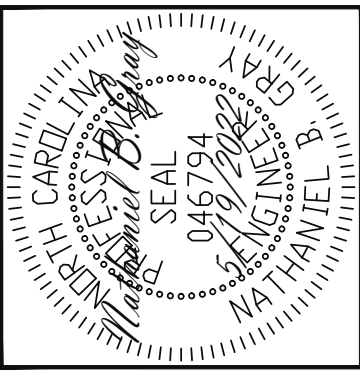

ENGINEERING SEAL VALID FOR 1 YEAR ONLY.  
The structural design of this plan is the property of Engineering Tech Associates, P.A. These plans are for the client listed only. Engineering Tech Associates, P.A. assumes no liability for these plans if construction or permitting takes place more than 1 year after the seal date without written permission from Engineering Tech Associates, P.A.

**Engineering Tech Associates, P.A.**  
STRUCTURAL ENGINEERS  
License No. C-3870  
318 W Millbrook Rd, Suite 201  
Raleigh, North Carolina 27609  
Phone (919) 844-1661

|                     |        |
|---------------------|--------|
| FRESH PAINT         |        |
| STRUCTURAL ADDENDUM |        |
| SCOPE               | TBD    |
| LOC                 | MASTER |

ENG: NBG/CMC  
DATE: 5/19/2022

PLAN:  
WISTERIA

PROJECT NO.  
22-30-062

SHEET NO.  
S1A

1 of 7

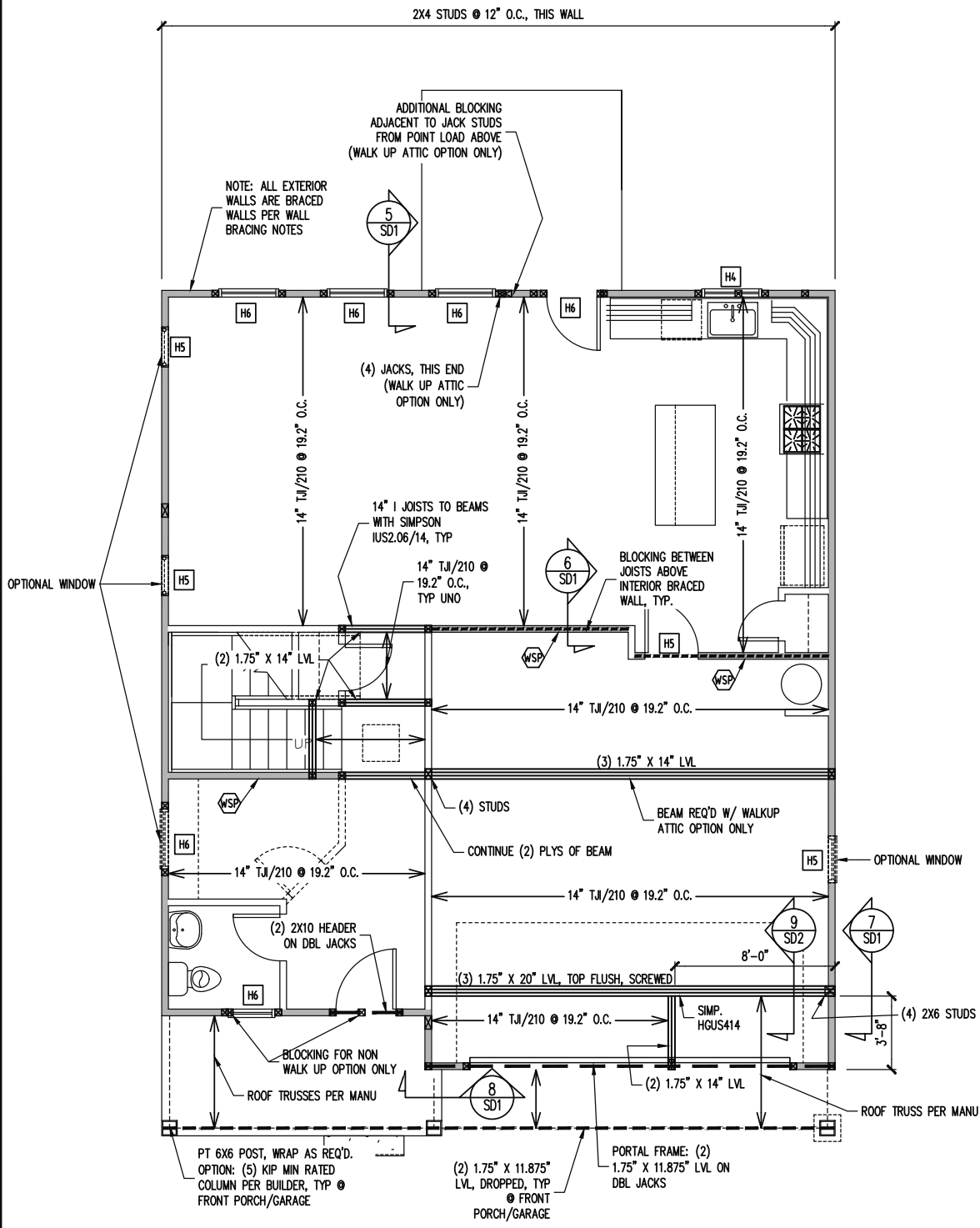

1ST FLOOR FRAMING PLAN  
ELEVATION A  
WALLS AND CEILING  
1/8" = 1'-0"

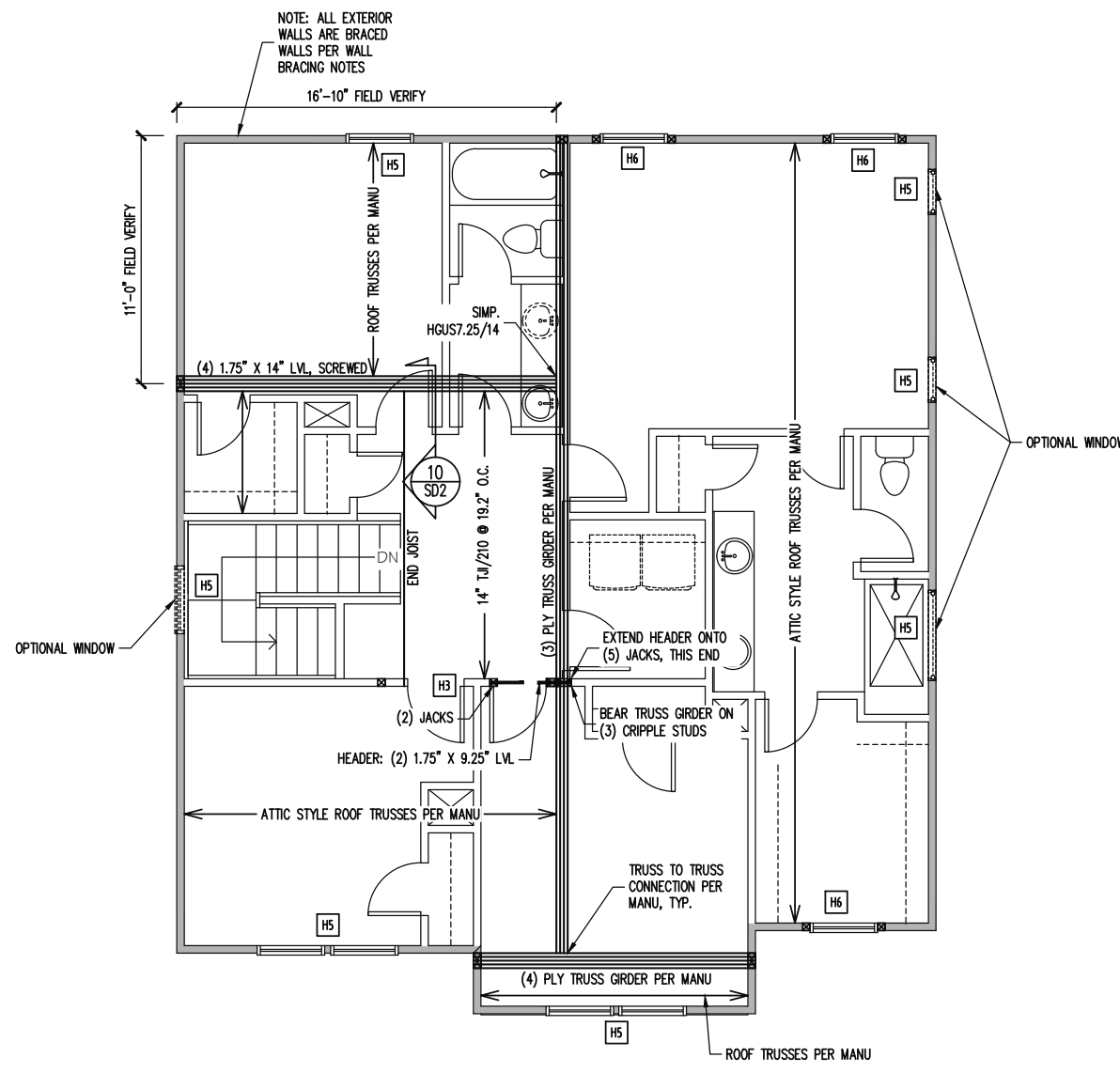

2ND FLOOR FRAMING PLAN  
WALK UP ATTIC OPTION  
ELEVATION A  
WALLS AND CEILING  
1/8" = 1'-0"

**TRUSS SUBSTITUTION**  
14" I-JOISTS PERMITTED TO BE SUBSTITUTED WITH 14" FLOOR TRUSSES.  
MAINTAIN MINIMUM SPACING AS CALLED OUT ON PLANS.  
SIMP. IUS/ITS2.06/XX HANGERS TO BE SUBSTITUTED WITH SIMP. IUS/ITS3.56/XX HANGER WHEN FLOOR TRUSSES HAVE BEEN INSTALLED.

**CONSTRUCTION SPECIFICATIONS**  
INSTANT REFERENCES  
REFER TO THE CONSTRUCTION SPECIFICATIONS SECTIONS FOR THE FOLLOWING INFORMATION:  
PART 1.01: CURRENT GOVERNING CODE  
PART 14: STUD SUPPORT FOR BEAMS  
PART 17: KING STUDS FOR EXTERIOR WALLS  
SEE DETAIL / CONSTRUCTION SPECIFICATIONS SHEETS FOR I-JOISTS ALLOWABLE SUBSTITUTIONS

**WALL BRACING**  
SHADED WALLS:  
ALL EXTERIOR STUD WALLS, EXTERIOR SIDE, ARE TO BE CONTINUOUSLY SHEATHED WITH 7/16 APA RATED OSB NAILED TO STUDS WITH 8d NAILS @ 6" O.C. AT PANEL EDGES, 12" O.C. IN PANEL FIELD.  
WSP - ONE SIDE OF INTERIOR WALL OR INSIDE OF EXTERIOR WALL WITH 3/8" MIN. THICKNESS WOOD STRUCTURAL PANELING. ATTACH WSP TO STUD WALL WITH 8d NAILS @ 4" O.C. AT PANEL EDGES, 8" O.C. IN PANEL FIELD.  
NOTES:  
PROVIDED CONTINUOUS SHEATHING = 145" MIN.  
REFERENCE PART 16.02 OF CONSTRUCTION SPECIFICATIONS FOR GENERAL WIND BRACING INFORMATION.

**HEADER SCHEDULE**

|    |                                      |
|----|--------------------------------------|
| H1 | SINGLE 2X4 TURNED FLAT (A)           |
| H2 | (2) 2X4'S ON SINGLE JACKS (B)        |
| H3 | (2) 2X10'S ON SINGLE JACKS (C)       |
| H4 | (2) 1.75" X 9.25" LVL'S ON DBL JACKS |
| H5 | (2) 2X8'S ON SINGLE JACKS            |
| H6 | (2) 2X8'S ON DBL JACKS               |

(A) TYPICAL FOR INTERIOR NON LOAD BEARING WALLS ONLY, ROUGH OPENING 38" MAX.  
(B) TYPICAL FOR INTERIOR NON LOAD BEARING WALLS ONLY, ROUGH OPNG 38" TO 74" MAX.  
(C) TYPICAL FOR ALL CONDITIONS NOT LISTED IN (A) OR (B) UNO.

NOTES:  
-HEADERS IN NON LOAD BEARING INTERIOR WALLS ARE NOT LABELED.

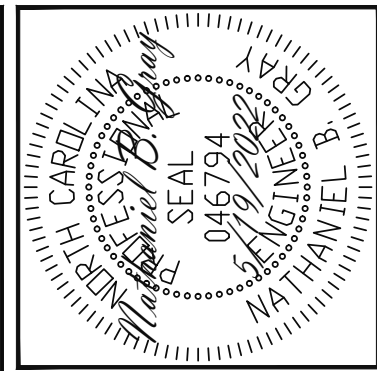

ENGINEERING SEAL VALID FOR 1 YEAR ONLY.  
The structural design of this plan is the property of Engineering Tech Associates, P.A. These plans are for the client listed only. Engineering Tech Associates, P.A. assumes no liability for these plans if construction or permitting takes place more than 1 year after the seal date without written permission from Engineering Tech Associates, P.A.

**Engineering Tech Associates, P.A.**  
STRUCTURAL ENGINEERS  
License No. C-3870  
318 W Millbrook Rd, Suite 201  
Raleigh, North Carolina 27609  
Phone (919) 844-1661

|                     |
|---------------------|
| FRESH PAINT         |
| STRUCTURAL ADDENDUM |
| TBD                 |
| MASTER              |
| SCOPE               |
| LOC                 |

ENG: NBG/CMC  
DATE: 5/19/2022

PLAN:  
WISTERIA

PROJECT NO.  
22-30-062

SHEET NO.  
S2A

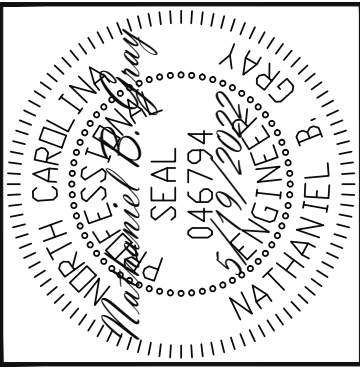

**TRUSS UPLIFT CONNECTORS**

EXPOSURE B, 120 MPH, ANY PITCH, 24" O.C. MAX ROOF TRUSS SPACING

TRUSSES SHALL BE ATTACHED TO SUPPORT WALL FOR UPLIFT RESISTANCE. CONTINUOUS OSB WALL SHEATHING BELOW PROVIDES CONTINUOUS UPLIFT RESISTANCE TO FOUNDATION. ALL TRUSSES SUPPORTED BY INTERMEDIATE SUPPORT WALLS, KNEEWALLS OR BEAMS SHALL BE ATTACHED TO SUPPORTING MEMBER PER SCHEDULE BELOW.

ROOF SPAN IS MEASURED HORIZONTALLY BETWEEN FURTHEST SUPPORT POINTS.

| ROOF SPAN | CONNECTOR   |
|-----------|---|
| UP TO 28' | CONNECTOR NAILING PER TABLE 602.3(1) NCRBC 2018 EDITION   |
| OVER 28'  | (1) SIMPSON H2.5A HURRICANE CLIP TO DBL TOP PLATE OR BEAM<br>OR (1) SIMPSON H3 CLIP TO SINGLE 2X4 PLATE |

NOTE: ALL EXTERIOR WALLS ARE BRACED PER WALL BRACING NOTES

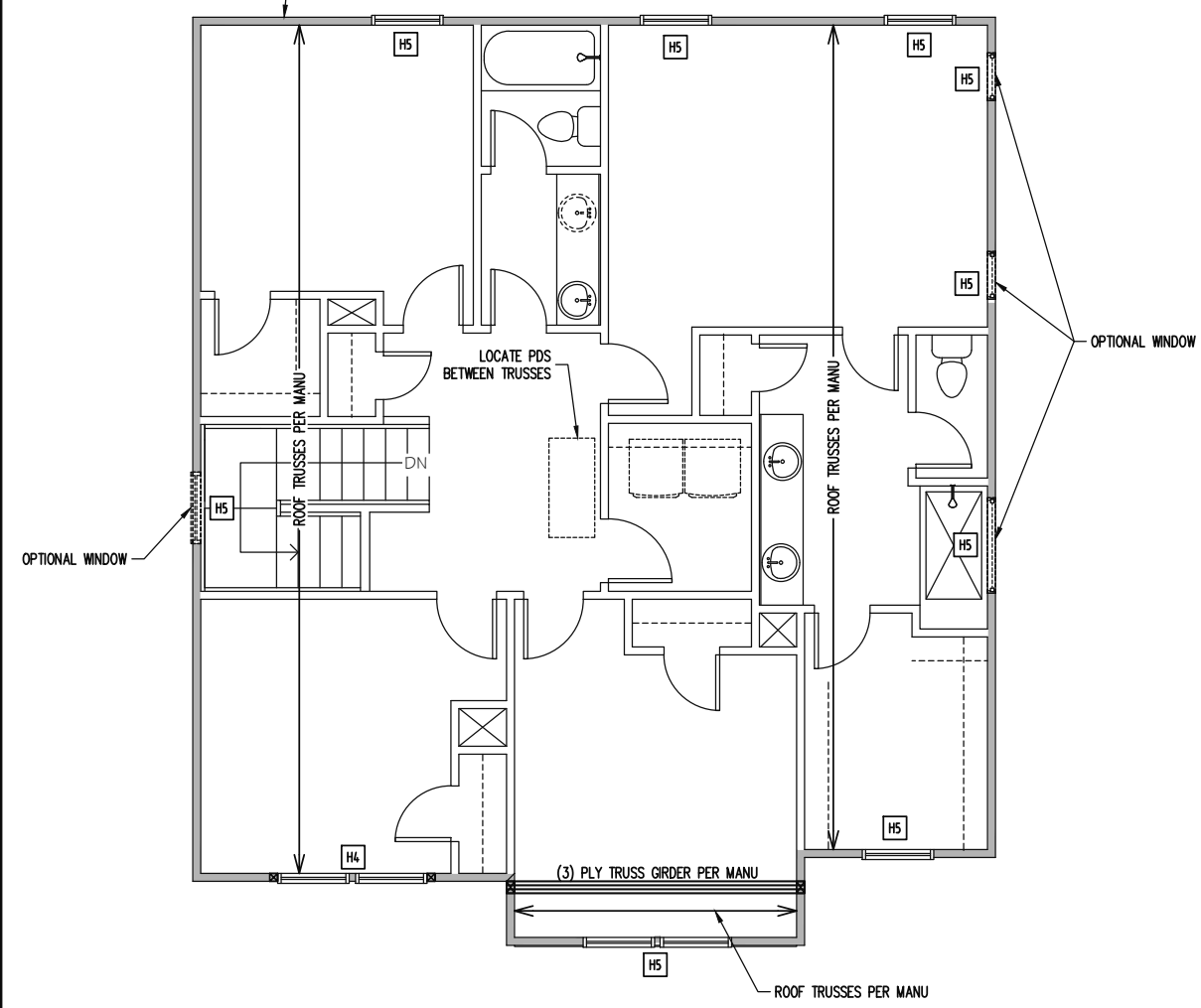

2ND FLOOR FRAMING PLAN  
ELEVATION A  
WALLS AND CEILING  
1/8" = 1'-0"

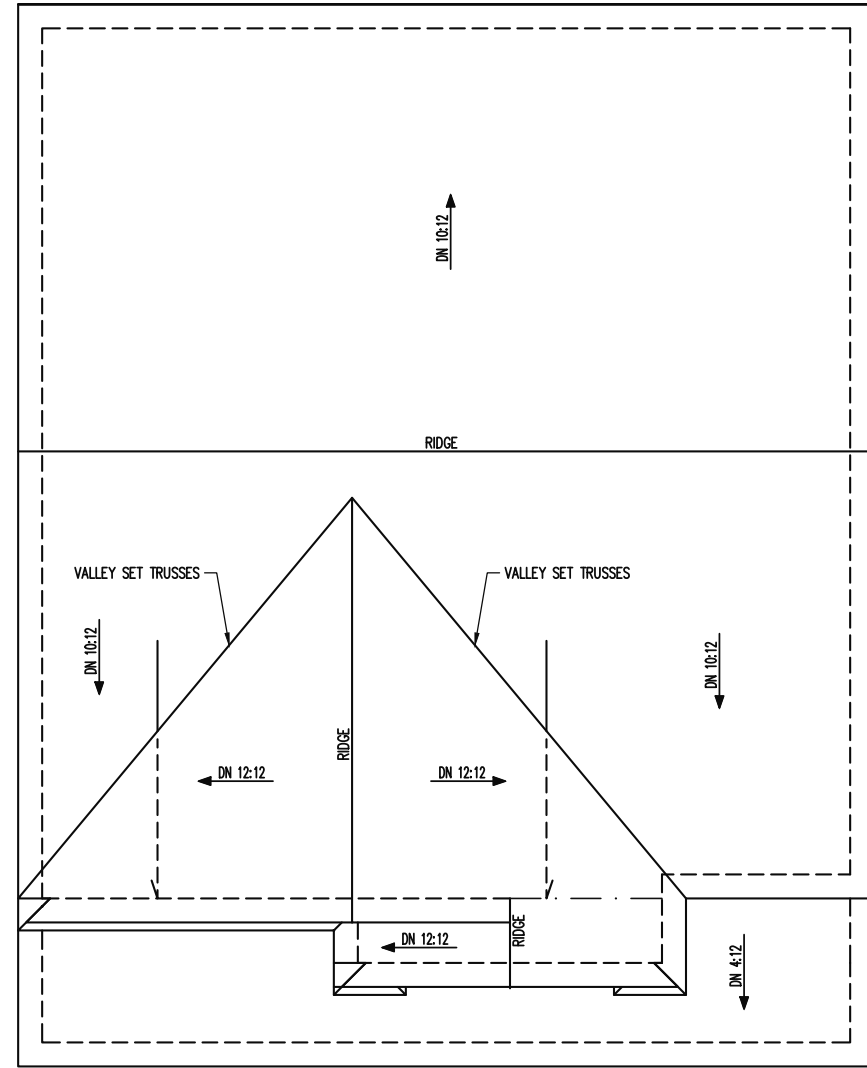

ROOF FRAMING PLAN  
ELEVATION A  
1/8" = 1'-0"

**FRAMING NOTES**

ROOF ONLY  
-ROOF TRUSSES PER MANU. TYPICAL U.N.O.  
-VERIFY ALL KNEEWALL HEIGHTS, ROOF PITCHES, AND ARCHITECTURAL OVERHANGS PRIOR TO CONSTRUCTION

**CONSTRUCTION SPECIFICATIONS**  
INSTANT REFERENCES

REFER TO THE CONSTRUCTION SPECIFICATIONS SECTIONS FOR THE FOLLOWING INFORMATION:  
PART 1.01: CURRENT GOVERNING CODE  
PART 14: STUD SUPPORT FOR BEAMS  
PART 17: KING STUDS FOR EXTERIOR WALLS

**WALL BRACING**

SHADED WALLS:  
ALL EXTERIOR STUD WALLS, EXTERIOR SIDE, ARE TO BE CONTINUOUSLY SHEATHED WITH 7/16 APA RATED OSB NAILED TO STUDS WITH 8d NAILS @ 6" O.C. AT PANEL EDGES, 12" O.C. IN PANEL FIELD.

NOTES:  
PROVIDED CONTINUOUS SHEATHING = 145' MIN.  
REFERENCE PART 16.02 OF CONSTRUCTION SPECIFICATIONS FOR GENERAL WIND BRACING INFORMATION.

**HEADER SCHEDULE**

- H1 SINGLE 2X4 TURNED FLAT (A)
  - H2 (2) 2X4'S ON SINGLE JACKS (B)
  - H3 (2) 2X10'S ON SINGLE JACKS (C)
  - H4 (2) 1.75" X 9.25" LVL'S ON DBL JACKS
  - H5 (2) 2X8'S ON SINGLE JACKS
- (A) TYPICAL FOR INTERIOR NON LOAD BEARING WALLS ONLY, ROUGH OPENING 38" MAX.  
(B) TYPICAL FOR INTERIOR NON LOAD BEARING WALLS ONLY, ROUGH OPNG 38" TO 74" MAX.  
(C) TYPICAL FOR ALL CONDITIONS NOT LISTED IN (A) OR (B) UNO.

NOTES:  
-HEADERS IN NON LOAD BEARING INTERIOR WALLS ARE NOT LABELED.

ENGINEERING SEAL VALID FOR 1 YEAR ONLY.  
The structural design of this plan is the property of Engineering Tech Associates, P.A. These plans are for the client listed only. Engineering Tech Associates, P.A. assumes no liability for these plans if construction or permitting takes place more than 1 year after the seal date without written permission from Engineering Tech Associates, P.A.

STRUCTURAL ENGINEERS  
License No. C-3870  
318 W Millbrook Rd, Suite 201  
Raleigh, North Carolina 27609  
TECH ASSOCIATES, P.A.  
Phone (919) 844-1661

|       |                     |
|-------|---------------------|
| SCOPE | FRESH PAINT         |
|       | STRUCTURAL ADDENDUM |
| LOC   | TBD                 |
|       | MASTER              |

ENG: NBG/CMC  
DATE: 5/19/2022

PLAN:  
WISTERIA

PROJECT NO.  
22-30-062

SHEET NO.  
S4A

4 of 7

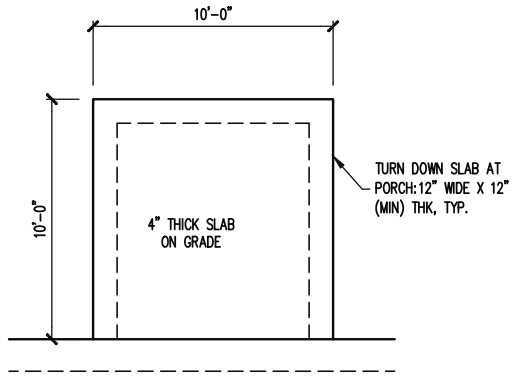

FOUNDATION PLAN  
OPTIONAL SCREENED PORCH  
MONOSLAB FOUNDATION  
1/8" = 1'-0"

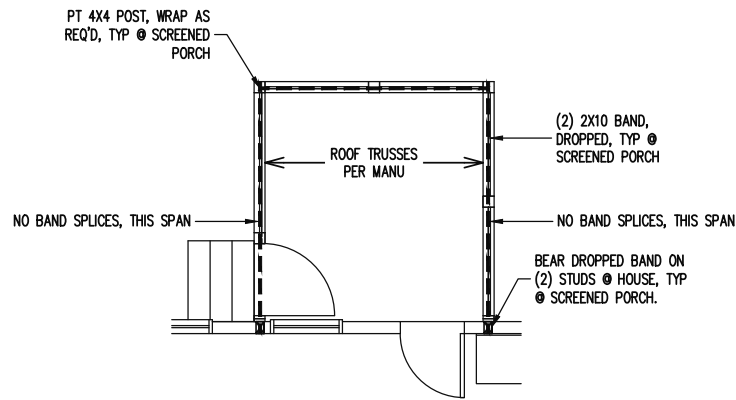

1ST FLOOR FRAMING PLAN  
OPTIONAL SCREENED PORCH  
1/8" = 1'-0"

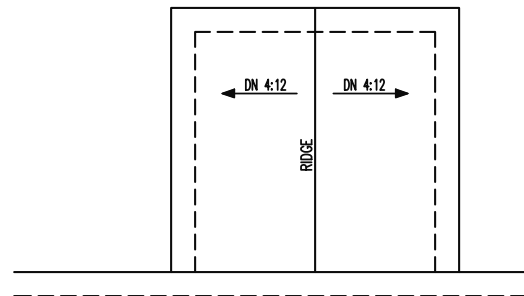

ROOF FRAMING PLAN  
OPTIONAL SCREENED PORCH  
1/8" = 1'-0"

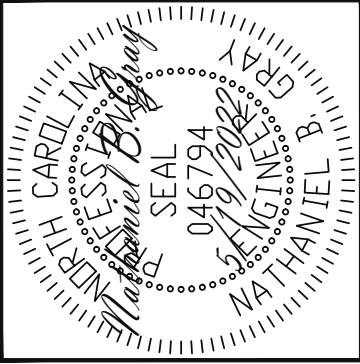

ENGINEERING SEAL VALID FOR 1 YEAR ONLY.  
The structural design of this plan is the property of Engineering Tech Associates, P.A. These plans are for the client listed only. Engineering Tech Associates, P.A. assumes no liability for these plans if construction or permitting takes place more than 1 year after the seal date without written permission from Engineering Tech Associates, P.A.

**Engineering Tech Associates, P.A.**  
STRUCTURAL ENGINEERS  
License No. C-3870  
318 W Millbrook Rd, Suite 201  
Raleigh, North Carolina 27609  
Phone (919) 844-1661

|                     |        |
|---------------------|--------|
| FRESH PAINT         |        |
| STRUCTURAL ADDENDUM |        |
| SCOPE               | TBD    |
| LOC                 | MASTER |

ENG: NBC/CMC  
DATE: 5/19/2022

PLAN:  
WISTERIA

PROJECT NO.  
22-30-062

SHEET NO.  
S5A

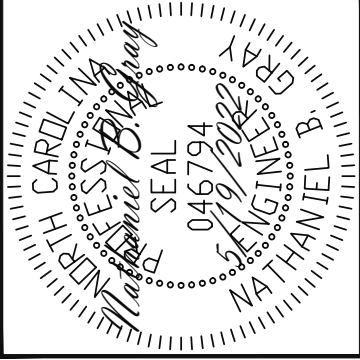
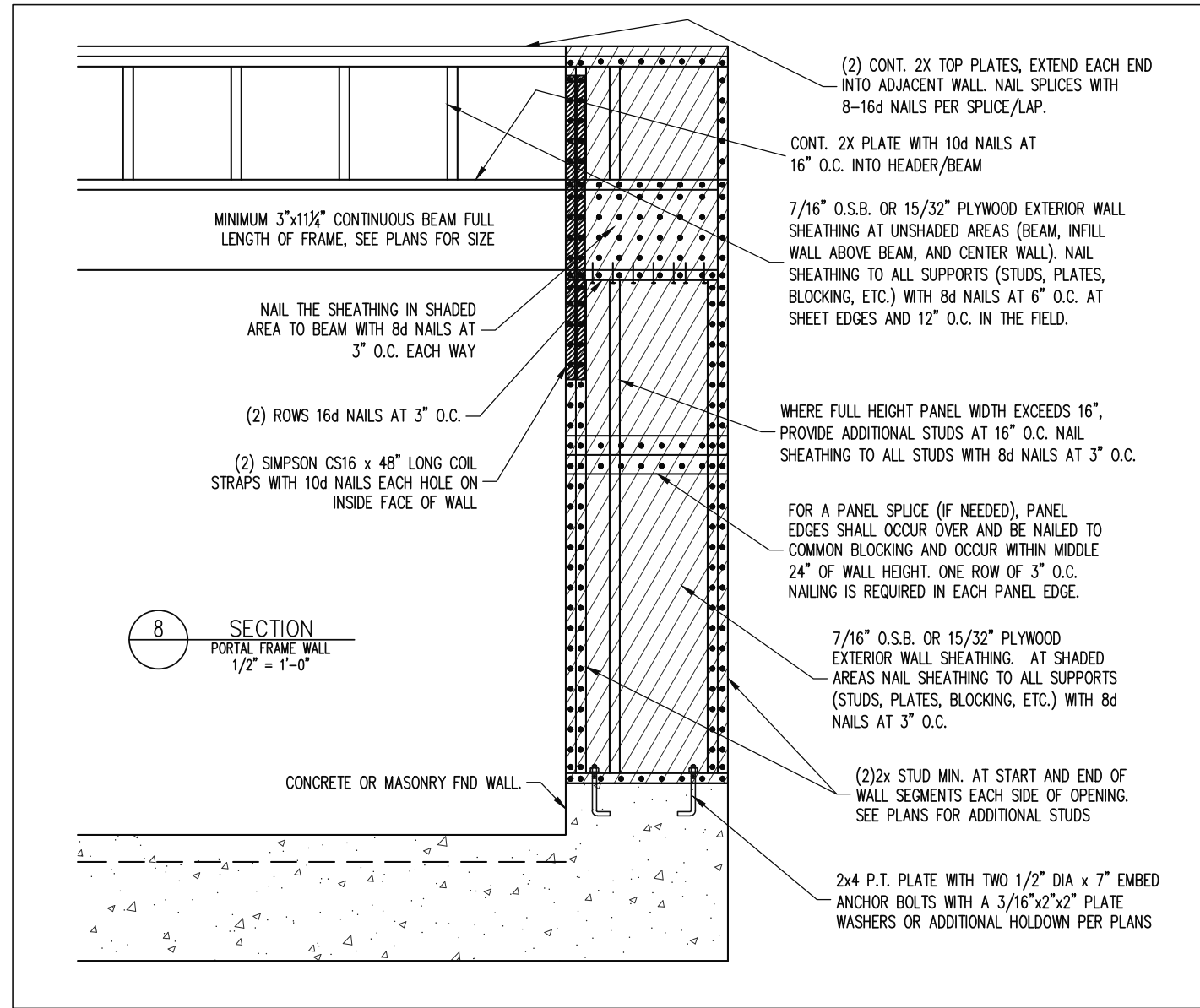
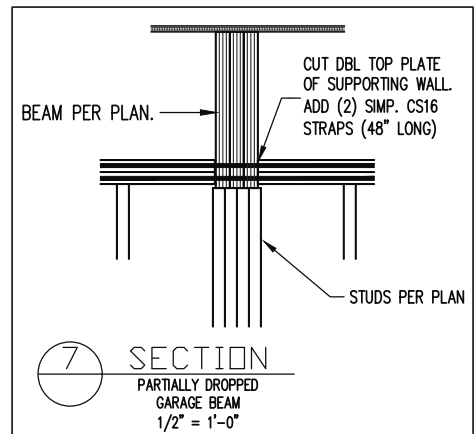
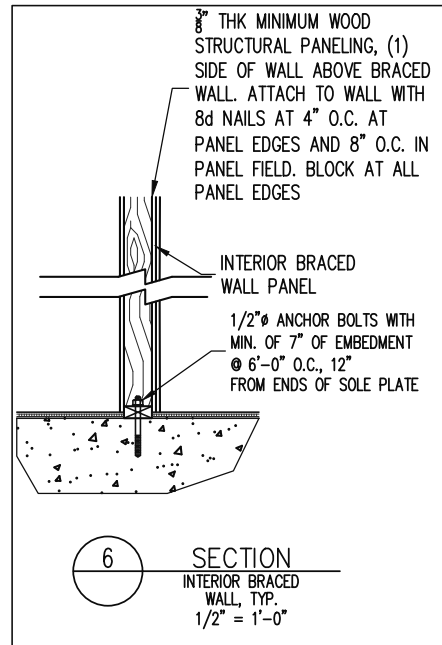
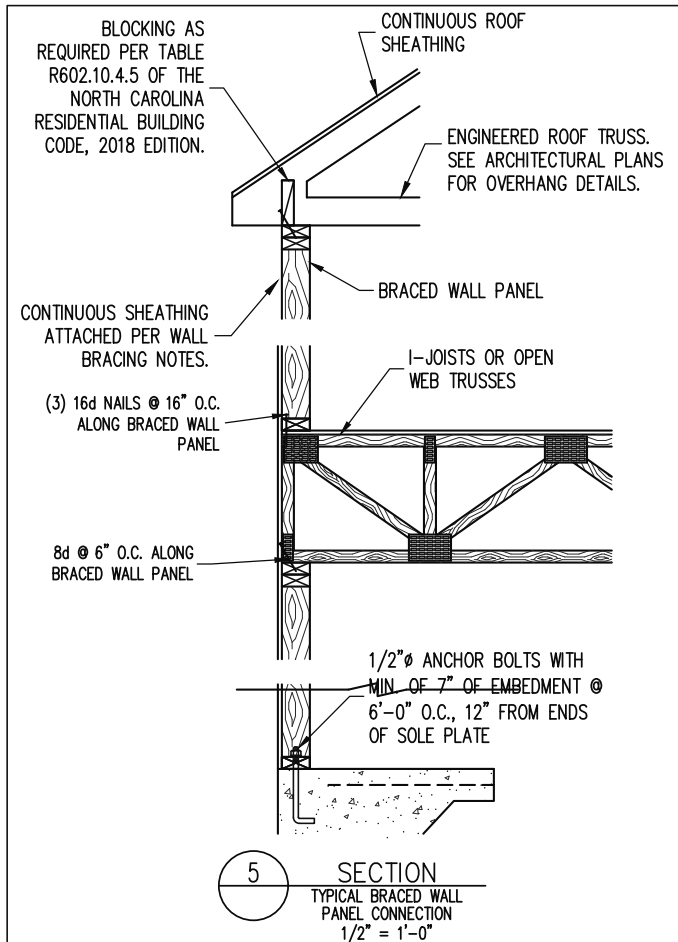
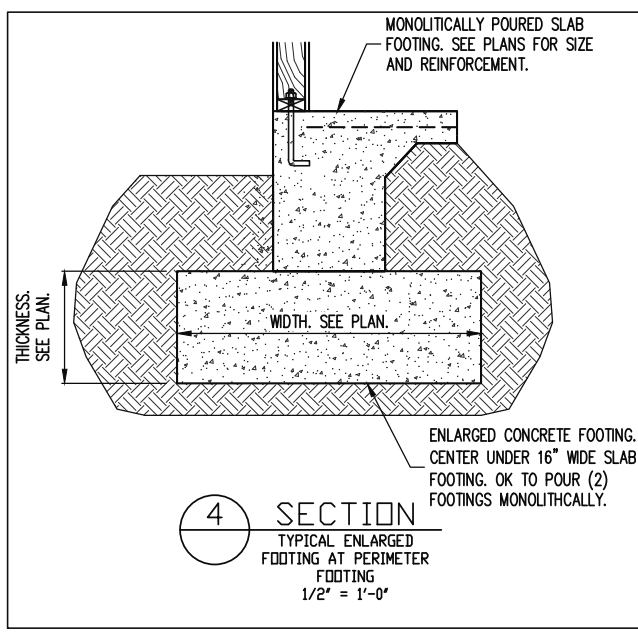
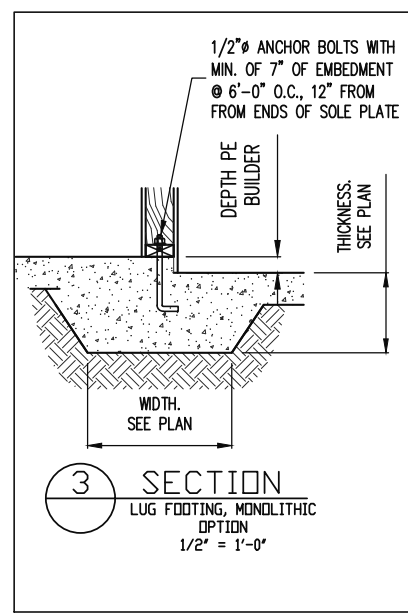
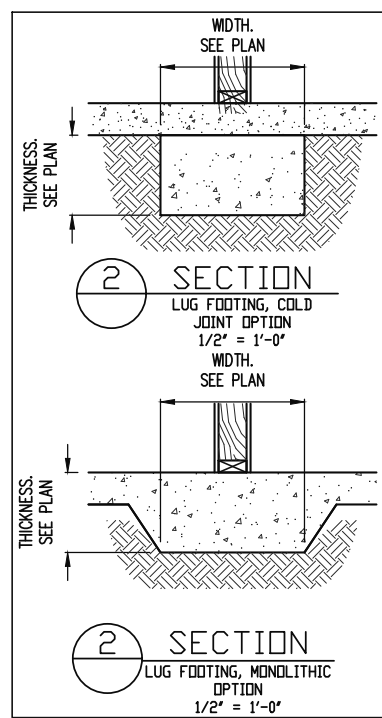
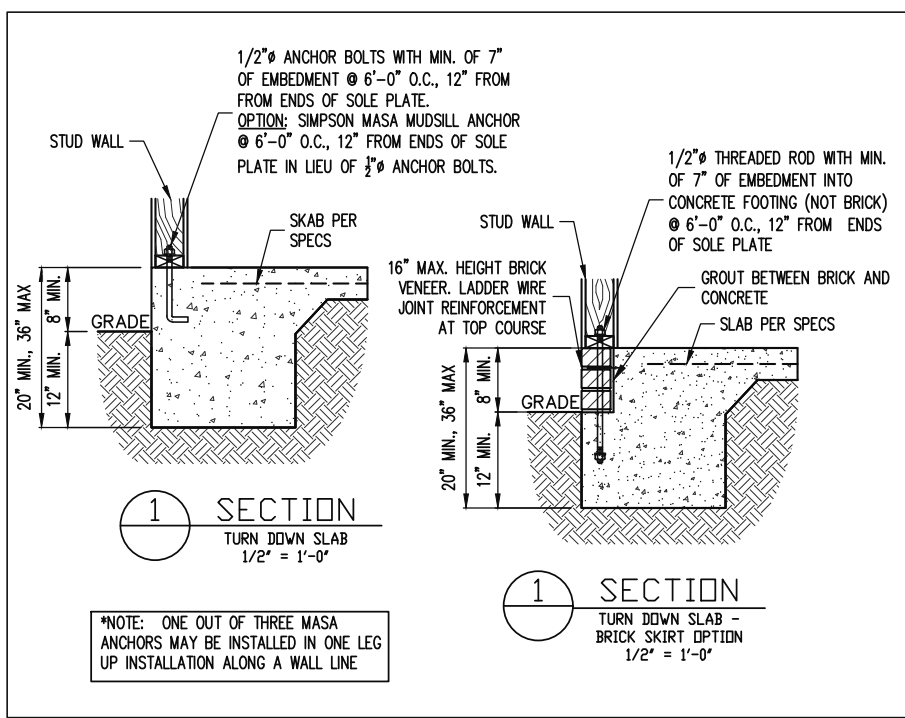

ENGINEERING SEAL VALID FOR 1 YEAR ONLY.  
The structural design of this plan is the property of Engineering Tech Associates, P.A. These plans are for the client listed only. Engineering Tech Associates, P.A. assumes no liability for these plans if construction or permitting takes place more than 1 year after the seal date without written permission from Engineering Tech Associates, P.A.

**Engineering Tech Associates, P.A.**  
STRUCTURAL ENGINEERS  
License No. C-3870  
318 W Millbrook Rd, Suite 201  
Raleigh, North Carolina 27609  
Phone (919) 844-1661

|       |                     |
|-------|---------------------|
| SCOPE | FRESH PAINT         |
|       | STRUCTURAL ADDENDUM |
| LOC   | TBD                 |
|       | MASTER              |

ENG: NBG/CMC  
DATE: 5/19/2022

PLAN:  
WISTERIA

PROJECT NO.  
22-30-062

SHEET NO.  
SD1

# CONSTRUCTION SPECIFICATIONS

## PART 1: GENERAL

- 1.01 CONSTRUCTION SHALL MEET THE REQUIREMENTS OF THE NORTH CAROLINA RESIDENTIAL CODE, 2018 EDITION.
- 1.02 DIMENSIONS SHOWN SHALL GOVERN OVER SCALE ON THESE DRAWINGS.
- 1.05 METHODS, PROCEDURES AND SEQUENCES OF CONSTRUCTION ARE THE RESPONSIBILITY OF THE CONTRACTOR, WHO SHALL TAKE ALL NECESSARY PRECAUTIONS TO MAINTAIN AND INSURE THE INTEGRITY OF THE STRUCTURE AT ALL STAGES OF CONSTRUCTION.

## PART 2: DESIGN LOADS

2.01 DESIGN LOADS SHALL CONFORM WITH THE TABLE BELOW:

| USE   | LIVE LOAD (PSF) | DEAD LOAD (PSF)    |
|---|-----------------|--------------------|
| BALCONIES, DECKS, ATTICS WITH FIXED STAIR ACCESS, DWELLING UNITS INCLUDING ATTICS WITH FIXED STAIR ACCESS, STAIRS, FIRE ESCAPES | 40              | 10                 |
| GARAGES (PASSENGER CARS ONLY)   | 50              | --                 |
| ATTICS (NO STORAGE, LESS THAN 5' HEADROOM)  | 10              | 10                 |
| ATTICS (WITH STORAGE)   | 20              | 10                 |
| ROOF  | 20              | 10 (15 FOR VAULTS) |

NOTES: - INDIVIDUAL STAIR TREADS ARE TO BE DESIGNED FOR THE UNIFORMLY DISTRIBUTED LIVE LOAD OF 40 PSF OR A 300 LB. CONCENTRATED LOAD ACTING OVER AN AREA OF 4 SQ. WHICHEVER PRODUCES THE GREATER STRESS.  
 - BUILDER TO VERIFY DEAD LOAD DOES NOT EXCEED 10 PSF WHEN HEAVY FLOOR OR ROOF FINISHES SUCH AS TILE OR SLATE ARE UTILIZED. NOTIFY ENGINEERING UNDER THESE CONDITIONS

- 2.02 INTERIOR WALLS: 5 PSF LATERAL.
- 2.03 BASIC WIND DESIGN VELOCITY OF 120 MPH.
- 2.04 SOIL BEARING CAPACITY 2000 PSF (PRESUMPTIVE).

## PART 5: CONCRETE AND SLABS ON GRADE

- 5.01 CAST IN PLACE CONCRETE SHALL BE OF NORMAL WEIGHT, 6% AIR ENTRAINMENT, AND SHALL HAVE A MINIMUM COMPRESSIVE STRENGTH OF 3000 PSI AT 28 DAYS TYP UNO. ALL CONCRETE, INCLUDING CONCRETE FOR FOOTINGS, IS TO BE CAST IN PLACE, TYP UNO.
- 5.02 REINFORCED CAST IN PLACE CONCRETE SHALL BE PROPORTIONED, MIXED AND PLACED IN ACCORDANCE WITH THE SPECIFICATIONS OF ACI 318, LATEST EDITION.
- 5.03 SLABS ON GRADE, IF ANY, SHALL CONTAIN SYNTHETIC POLYPROPYLENE FIBRILLATED MICRO FIBERS, FIBER LENGTH 1 1/2", DOSAGE RATE 1 1/2 LBS/CU YD. SLAB TO BE PLACED ON A 6 MIL VAPOR BARRIER ON 2" MIN GRANULAR FILL ON SOIL WITH 90% MIN STANDARD PROCTOR DENSITY. VAPOR BARRIER MAY BE OMITTED FOR SLABS NOT IN ENCLOSED AREAS

## PART 6: REBAR AND WIRE REINFORCEMENT

- 6.01 REBAR SHALL BE DEFORMED STEEL CONFORMING TO ASTM A615 GRADE 60 TYP UNO
- 6.02 LAP SPLICES SHALL BE CLASS B AS DEFINED BY ACI 318, TYP UNO
- 6.03 WIRE REINFORCEMENT SHALL BE 9 GA AND SHALL CONFORM TO ASTM A1064.

## PART 7: MASONRY

- 7.01 CONCRETE MASONRY UNITS SHALL CONFORM TO ASTM C90 AND C55, NORMAL WEIGHT, FM = 1,500 PSI MIN
- 7.02 CLAY MASONRY UNITS SHALL CONFORM TO ASTM C62-17 GRADE SW
- 7.03 MORTAR SHALL BE TYPE S. MORTAR AND GROUT SHALL CONFORM TO ASTM C476, MIN COMPRESSIVE STRENGTH OF 2000 PSI.

7.04 MASONRY CONSTRUCTION SHALL CONFORM TO THE SPECIFICATIONS OF ACI 530

7.05 LADDER WIRE REINFORCEMENT SHALL CONFORM TO ASTM A951. 6" MIN LAPS FOR CONTINUOUS WALL APPLICATIONS

## PART 8: BOLTS AND LAG SCREWS

8.03 ANCHOR RODS AND BOLTS SHALL CONFORM TO ASTM F1554-15 GRADE 36 UNO. BENT ANCHOR BOLTS SHALL HAVE A 2" MIN HOOK UNO

## PART 9: DRIVEN FASTENERS

9.01 NAILS, SPIKES AND STAPLES SHALL CONFORM TO ASTM F 1667- 05. NAILS ARE TO BE COMMON WIRE OR BOX

## PART 10: DIMENSIONAL LUMBER

10.01 SOLID SAWN WOOD FRAMING DESIGN IS BASED ON NO. 2 SPRUCE PINE FIR OR SYP #2 FOR JOISTS, RAFTERS, GIRDERS, BEAMS, STUDS, ETC.

## PART 11: ENGINEERED LUMBER

11.01 LVL OR PSL MINIMUM ALLOWABLE DESIGN STRESSES ARE AS FOLLOWS:  
 E = 1.9 X 10<sup>6</sup> PSI, F<sub>b</sub> = 2600 PSI, F<sub>v</sub> = 285 PSI, F<sub>c</sub> = 750 PSI  
 LSL MINIMUM ALLOWABLE DESIGN STRESSES ARE AS FOLLOWS:  
 E = 1.3 X 10<sup>6</sup> PSI, F<sub>b</sub> = 1700 PSI, F<sub>v</sub> = 400 PSI, F<sub>c</sub> = 680 PSI

11.02 LVL OR PSL MEMBERS MAY BE RIPPED FROM DEEPER MEMBERS TO MATCH THE MEMBER DEPTH SPECIFIED IN THE PLANS

## PART 12: PRESSURE TREATED LUMBER

12.01 LUMBER IN CONTACT WITH THE GROUND, CONCRETE OR MASONRY SHALL BE PRESSURE TREATED IN ACCORDANCE WITH ANPA STANDARD C-15. ALL OTHER EXPOSED LUMBER SHALL BE TREATED IN ACCORDANCE WITH ANPA STANDARD C-2 OR BY ANY METHOD GIVING EQUAL PROTECTION. THE BUILDING CODE OFFICE MAY ALSO APPROVE A NATURAL DECAY RESISTANT WOOD PER SECTION 19-6(A)

## PART 14: STUD SUPPORTS FOR BEAMS

14.01 STEEL ENGINEERED LUMBER, AND FLITCH PLATE BEAMS BEARING ON A STUD WALL SHALL BEAR AS FOLLOWS:

- WHEN THE BEAM IS PERPENDICULAR TO, OR SKEWED RELATIVE TO THE WALL, THE BEAM SHALL BEAR FULL WIDTH ON THE SUPPORTING WALL INDICATED AND SHALL BE SUPPORTED BY A MINIMUM OF THREE GANGED STUDS, OR A GANGED STUD COLUMN WITH A NUMBER OF STUDS SUCH THAT THE STUD COLUMN IS AT LEAST AS WIDE AS THE TRUE WIDTH OF THE BEAM BEING SUPPORTED, WHICHEVER IS GREATER, TYP UNO. FOR THE SKEWED CONDITION PARTICULAR CARE SHALL BE TAKEN TO ENSURE STUD COLUMN IS CENTERED ON THE BEAM
- BEAMS BEARING ONTO THE END OF A STUD WALL PARALLEL TO THE BEAM SHALL BEAR A MINIMUM OF 4 1/2" ONTO THE WALL AND BE SUPPORTED BY A TRPL STUD GANGED COLUMN TYP UNO.

14.02 DIMENSIONAL LUMBER BEAMS BEARING ON A STUD WALL SHALL BEAR AS FOLLOWS:

- WHEN THE BEAM IS PERPENDICULAR TO, OR SKEWED RELATIVE TO THE WALL, THE BEAM SHALL BEAR FULL WIDTH ON THE SUPPORTING WALL INDICATED (LESS 1 1/2" TO ALLOW FOR A CONTINUOUS RIM JOIST WHERE APPLICABLE) AND SHALL BE SUPPORTED BY A GANGED STUD COLUMN THE SAME WIDTH AS THE BEAM TYP UNO. (E.G. A TRIPLE 2X10 IS TO BE SUPPORTED BY (3) STUDS). FOR THE SKEWED CONDITION PARTICULAR CARE SHALL BE TAKEN TO ENSURE STUD COLUMN IS CENTERED ON THE BEAM
- BEAMS BEARING ONTO THE END OF A STUD WALL PARALLEL TO THE BEAM SHALL BEAR A MINIMUM OF 3" ONTO THE WALL AND BE SUPPORTED BY A DBL STUD GANGED COLUMN TYP UNO.

14.03 EXTRA JOISTS BEARING ON A STUD WALL PERPENDICULAR TO OR SKEWED RELATIVE TO THE BEAM SHALL BE SUPPORTED BY ONE ADDITIONAL STUD.

14.04 STUDS THAT ARE GANGED TO FORM A COLUMN SHALL HAVE ADJACENT STUDS WITHIN THE COLUMN NAILED TOGETHER WITH ONE ROW OF 10d NAILS AT 8" O.C. (TWO ROWS OF 10d NAILS @ 8" O.C., 3" APART, FOR 2X8 OR 2X10 STUDS) ALL COLUMNS SHALL BE CONTINUOUS DOWN TO THE FOUNDATION OR OTHER PROPERLY DESIGNED STRUCTURAL ELEMENT SUCH AS A BEAM. COLUMNS TRANSFERRING LOADS THROUGH FLOOR LEVELS SHALL BE SOLIDLY BLOCKED FOR THE FULL WIDTH OF THE STUD COLUMN

WITHIN THE CAVITY FORMED BY THE FLOOR JOISTS.

## PART 15: NAILING OF MULTI PLY WOOD BEAMS

15.01 SOLID SAWN LUMBER JOISTS THAT ARE GANGED TO FORM A BEAM SHALL HAVE ADJACENT MEMBERS IN THE BEAM NAILED TOGETHER WITH THREE ROWS OF 10d NAILS @ 16" O.C. FOR 2X10 OR LARGER, TWO ROWS OF 10d NAILS @ 16" O.C. FOR 2X8, ONE ROW OF 10d NAILS @ 16" O.C. FOR 2X6 OR SMALLER. STAGGER ROWS 5" MIN.

15.02 LVL MEMBERS THAT ARE GANGED TO FORM A BEAM SHALL HAVE ADJACENT MEMBERS IN THE BEAM FASTENED TOGETHER PER MANUFACTURERS RECOMMENDATIONS, TYP UNO

## PART 16: WALL FRAMING AND BRACING

16.01 STUD WALLS SHALL CONSIST OF 2X4 STUDS SPACED AT 16" O.C. UNO. STUDS SHALL BE CONTINUOUS FROM SOLE PLATE AT FLOOR TO DOUBLE TOP PLATE AT THE CEILING OR ROOF. NO INTERMEDIATE BANDS OR PLATES SHALL CAUSE DISCONTINUITIES IN A STUD WALL EXCEPT AS REQUIRED FOR DOOR OR WINDOW OPENINGS. THE KING STUDS FOR SUCH OPENINGS SHALL BE CONTINUOUS, TYP UNO.  
 MAX ALLOWABLE WALL HEIGHTS FOR EXTERIOR STUD WALLS, WITH SOLE PLATE AND DBL TOP PLATE AND 7/16" OSB EXTERIOR BRACING AND ROW OF 2X4 / 2X6 PURLINS AT 8' HEIGHT (AND AT 16' HEIGHT FOR TALL WALLS), TYP UNO:  
 2X4 @ 16" O.C.: 11'-0" 2X6 @ 16" O.C.: 17'-0"  
 2X4 @ 12" O.C.: 12'-0" 2X6 @ 12" O.C.: 18'-8"  
 DBL 2X4 @ 16" O.C.: 13'-4" DBL 2X6 @ 16" O.C.: 21'-0"

16.02 FOR WALL BRACING THE FOLLOWING SHALL APPLY:  
 -BLOCKING AT UNSUPPORTED PANEL EDGES IS REQUIRED TYP UNO.  
 -WALL BRACING IS BY ENGINEERED DESIGN AND NOT PRESCRIPTIVE PER SECTION 602.10 OF THE 2018 NCR. CONTINUOUS SHEATHING HAS BEEN PROVIDED, ALONG WITH ALTERNATIVE METHODS TO INSURE THE MINIMUM INTENT OF SECTION 602.10 OF THE 2018 NCR HAS BEEN MET AND EXCEEDED.  
 -BRACED WALL PANELS SHALL BE FASTENED IN ACCORDANCE WITH TABLE 602.3(1) TO PROVIDE CONTINUOUS PANEL UPLIFT RESISTANCE AND COMPLIANCE WITH NCRBC R602.3.5 AND R802.11 UNLESS NOTED OTHERWISE ON STRUCTURAL PLANS.  
 -MAY SUBSTITUTE WSP FOR GB  
 -SINGLE JOIST, CONTINUOUS RIM JOIST, OR BLOCKING OF EQUAL DEPTH IS REQUIRED ABOVE AND BELOW ALL BRACED WALLS. NAIL BLOCKING ABOVE WALL TO TOP PLATE WITH 16d TOE NAILS @ 6" O.C. NAIL SOLE PLATE OF BRACED WALL TO BLOCKING BELOW WITH (3) 16d NAILS @ 16" O.C. BLOCKING AT HORIZONTAL JOINTS IN BRACED WALL LINES ONLY REQUIRED AT SHADED WALLS, UNO.

## PART 17: KING STUDS

17.01 KING STUDS FOR OPENINGS IN EXTERIOR WALLS SHALL BE AS FOLLOWS:

| STUD SIZE | NUMBER OF KING STUDS |       |        |        |        |
|-----------|----------------------|-------|--------|--------|--------|
|           | 5'-0"                | 9'-0" | 13'-0" | 17'-0" | 21'-0" |
| 2X4       | 1                    | 2     | 3      | 4      | 5      |
| 2X6       | 1                    | 1     | 2      | 2      | 2      |
| 2X8       | 1                    | 1     | 1      | 1      | 2      |

## PART 18: SUBSTITUTIONS

18.01 MATERIAL OR MEMBER SIZE SUBSTITUTIONS OR PLAN DEVIATIONS REQUIRE THE WRITTEN AUTHORIZATION OF THE DESIGNERS. UNAUTHORIZED DEVIATIONS ARE THE SOLE RESPONSIBILITY OF THE CONTRACTOR.

## PART 19: OWNERSHIP OF STRUCTURAL DESIGN

19.01 THE STRUCTURAL DESIGN OF THIS PLAN IS THE PROPERTY OF ENGINEERING TECH ASSOCIATES (ETA). THESE PLANS ARE FOR THE ONE TIME USE AT THE LOCATION INDICATED AND FOR THE CLIENT LISTED. ETA ASSUMES NO LIABILITY FOR THESE PLANS IF THEY ARE REPRODUCED, IN WHOLE OR IN PART, FOR CONSTRUCTION AT ANY OTHER LOCATION WITHOUT WRITTEN PERMISSION FROM ETA

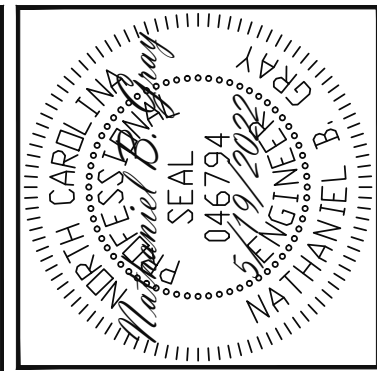
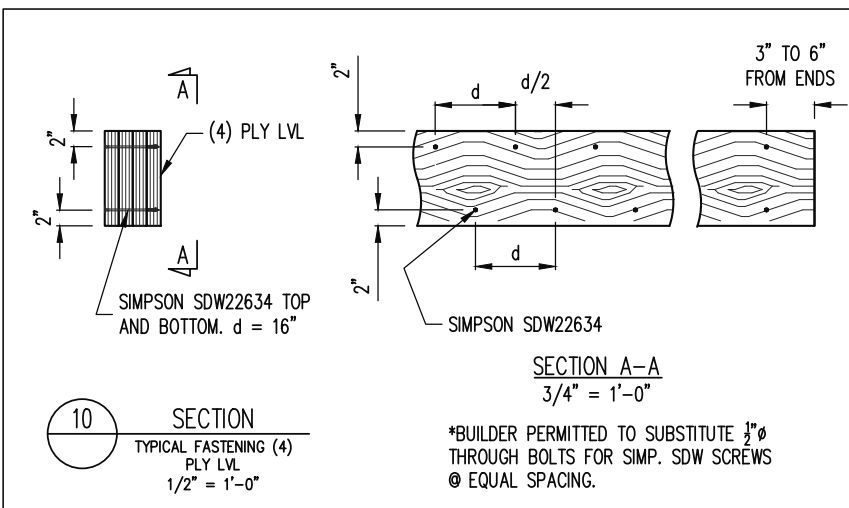
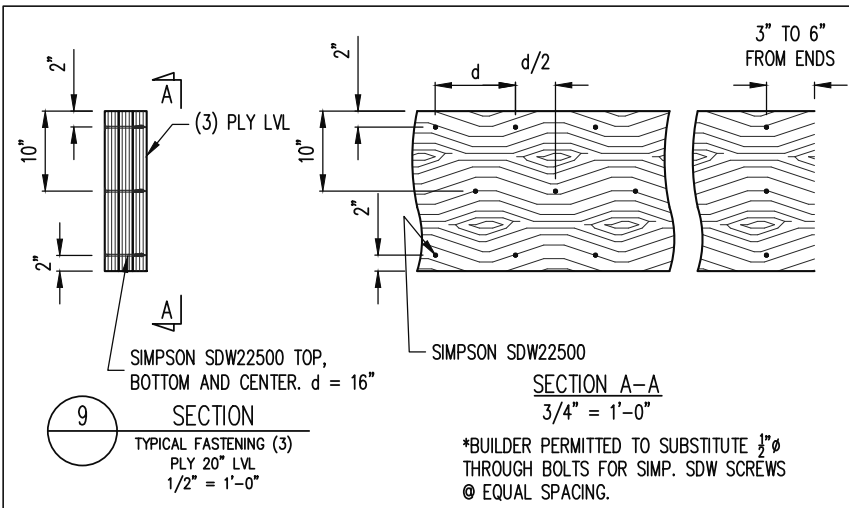

**Engineering Tech Associates, P.A.**  
 STRUCTURAL ENGINEERS  
 License No. C-3870  
 318 W Millbrook Rd, Suite 201  
 Raleigh, North Carolina 27609  
 Phone (919) 844-1661

|       |                     |
|-------|---------------------|
| SCOPE | FRESH PAINT         |
|       | STRUCTURAL ADDENDUM |
| LOC:  | TBD                 |
|       | MASTER              |

ENG: NBG/CMC  
 DATE: 5/19/2022

PLAN:  
 WISTERIA

PROJECT NO.  
 22-30-062

SHEET NO.  
 SD2  
 7 of 7

## NOTES

THE BUILDER IS RESPONSIBLE FOR REVIEWING PLANS PRIOR TO CONSTRUCTION. THE BUILDER SHALL IMMEDIATELY CONTACT THE ENGINEER OF RECORD (EOR) BEFORE PROCEEDING IF THE FOLLOWING CONDITIONS ARE NOTED BEFORE OR DURING CONSTRUCTION:

- THE WORKING PLANS DO NOT BEAR THE SEAL OF THE EOR
- THE PLANS CONTAIN DISCREPANT OR INCOMPLETE INFORMATION

ANY ERRORS DUE TO A FAILURE TO FOLLOW THE ABOVE PROCEDURES SHALL NOT BE THE RESPONSIBILITY OF THE EOR. FURTHERMORE, IT IS THE RESPONSIBILITY OF THE BUILDER TO ENSURE THAN ANY REVISIONS ISSUED BY THE EOR ARE PROMPLY DISTRIBUTED TO THE SUBCONTRACTORS

THE EOR DOES NOT PERFORM FENESTRATION OR VENTING CALCULATIONS OR ANY OTHER CALCULATIONS THAT ARE NOT DIRECTLY RELATED TO STRUCTURAL ENGINEERING.

ROOF AND FLOOR TRUSSES TO BE DESIGNED BY AN ENGINEER REGISTERED BY THE STATE. FINAL TRUSS DRAWING SHOULD BE SUBMITTED TO THE EOR FOR REVIEW

## ABBREVIATIONS

|                         |                             |                            |
|-------------------------|-----------------------------|----------------------------|
| ABV ABOVE               | FND FOUNDATION              | TJ TRIPLE JOIST            |
| B. BOTH                 | FTG FOOTING                 | TYP TYPICAL                |
| B.E. BOTH ENDS          | HDG HOT DIPPED              | TRPL TRIPLE                |
| BTWN BETWEEN            | GALVANIZED                  | TSP TRIPLE STUD POCKET     |
| CIP CAST IN PLACE       | HGR HANGER                  | UNO UNLESS NOTED OTHERWISE |
| CONC CONCRETE           | LVL LAMINATED VENEER LUMBER | XJ EXTRA JOIST             |
| CS CONTINUOUS SHEATHING | NTS NOT TO SCALE            |                            |
| DIA DIAMETER            | O.C. ON CENTER              |                            |
| DBL DOUBLE              | PSL PARALLEL STRAND LUMBER  |                            |
| DJ DOUBLE JOIST         | PT PRESSURE TREATED         |                            |
| DSP DBL STUD POCKET     | QJ QUAD JOIST               |                            |
| EQ EQUAL                | SP STUD POCKET              |                            |
| EA EACH                 | SQ SQUARE                   |                            |
| FLG FLANGE              |                             |                            |
| FL PL FLITCH PLATE      |                             |                            |
| FLR FLOOR               |                             |                            |

## ALLOWABLE I-JOIST SUBSTITUTION

NOTE: MAINTAIN JOIST DEPTH, DIRECTION, AND SPACING SPECIFIED ON PLANS.

| MANUFACTURER  | DEPTH | SERIES    | SIMPSON FACE MOUNT HGR | SIMPSON TOP FLANGE HGR |
|---------------|-------|-----------|------------------------|------------------------|
| BLUELINX      | 14"   | BLI 40    | IUS2.56/14             | ITS2.56/14             |
| BOISE CASCADE | 14"   | BCI 5000s | IUS2.06/14             | ITS2.06/14             |
| BOISE CASCADE | 14"   | BCI 6000S | IUS2.37/14             | ITS2.37/14             |
| LP CORP       | 14"   | LPI 20+   | IUS2.56/14             | ITS2.56/14             |
| NORDIC        | 14"   | NI 40X    | IUS2.56/14             | ITS2.56/14             |
| ROSEBURG      | 14"   | RFPI 40s  | IUS2.56/14             | ITS2.56/14             |
| WEYERHAEUSER  | 14"   | TJI 210   | IUS2.06/14             | ITS2.06/14             |
| WEYERHAEUSER  | 14"   | EEL-20    | IUS2.37/14             | ITS2.73/14             |

JOISTS NOT LISTED IN THE ABOVE TABLE MAY BE USED PROVIDED THEY MEET OR EXCEED THE PROPERTIES OF THOSE LISTED. SUBSTITUTE USP BRAND HANGERS WITH EQUIVALENT VALUES AS DESIRED.

ENGINEERING SEAL VALID FOR 1 YEAR ONLY.

The structural design of this plan is the property of Engineering Tech Associates, P.A. These plans are for the client listed only. Engineering Tech Associates, P.A. assumes no liability for these plans if construction or permitting takes place more than 1 year after the seal date without written permission from Engineering Tech Associates, P.A.