

**CODES AND STANDARDS**

**PARTIAL LIST OF CODES AND STANDARDS APPLICABLE TO PROJECT**

1. THE INTERNATIONAL BUILDING CODE 2018  
NORTH CAROLINA BUILDING CODE 2018
2. CODE REQUIREMENTS FOR CONCRETE  
ACI 318, NC BLDG CODE CHAPTER 19
3. WIND AND SNOW LOAD CRITERIA  
ASCE 7-05, NC BLDG CODE CHAPTER 16

**GENERAL CONSTRUCTION NOTES**

BE ATTAINED IN ITS COMPLETED STATE. WHILE UNDER CONSTRUCTION, ANY TEMPORARY BRACING OR SHORING WHICH MAY BE REQUIRED TO MAINTAIN STABILITY PRIOR TO COMPLETION SHALL BE THE RESPONSIBILITY OF THE CONTRACTOR

BUILDING CODES, THE LATEST EDITIONS AVAILABLE AT THE TIME OF PERMITTING. THE PROVISIONS OF THE INTERNATIONAL BUILDING CODE MEET OR EXCEED THAT OF PREVIOUS VERSIONS OF THE STANDARD BUILDING CODE. REFERENCED SECTIONS OF THE BUILDING CODE ARE NOT INTENDED TO BE ALL INCLUSIVE; THAT IS, OTHER PERTINENT SECTIONS MAY NOT BE NOTED ON THE DRAWINGS BUT SHALL STILL BE THE RESPONSIBILITY OF THE GENERAL CONTRACTOR.

3. THE DIMENSIONS, LOCATION, AND ELEVATIONS OF ANY EXISTING STRUCTURES WHICH RELATE TO OR INFLUENCE NEW CONSTRUCTION SHALL BE VERIFIED BY FIELD MEASUREMENT BY THE CONTRACTOR PRIOR TO PREPARATION AND SUBMISSION OF CHECKED SHOP DRAWINGS TO THE ENGINEER OR RECORD FOR REVIEW..

THE CONSTRUCTION SHALL BE THE RESPONSIBILITY OF THE GENERAL CONTRACTOR.

**DESIGN CRITERIA**

1. DEAD LOAD  
FRAMING: 4 psf  
METAL ROOFING (29 GA.) 0.75 psf  
METAL ROOFING (26 GA.) 1.00 psf
2. LIVE LOAD 20 psf
3. SNOW LOAD  
GROUND SNOW LOAD:  $P_g = 25$  psf  
SNOW EXPOSURE FACTOR:  $C_e = 1.0$   
IMPORTANCE FACTOR:  $I = 1.0$   
THERMAL FACTOR:  $C_t = 1.2$   
ROOF SNOW LOAD:  $P_s = 21.0$  psf
4. WIND LOAD  
WIND SPEED: 115 mph  
IMPORTANCE FACTOR:  $I = 1.0$   
BUILDING CATEGORY: U  
EXPOSURE CATEGORY: C  
CLASSIFICATION: PARTIALLY ENCLOSED
5. SEISMIC LOAD  
IMPORTANCE FACTOR:  $I = 1.0$   
SOIL CLASSIFICATION: O  
MAPPED ACCELERATIONS:  $S_s = 0.50g$   
 $S_1 = 0.15g$   
SOIL RESPONSE:  $S_{ms} = 0.50g$   
 $S_{m1} = 0.21g$   
DESIGN SPECTRAL RESPONSE ACCELERATIONS AT 5% DAMPENING:  
 $S_{ds} = 0.33g$   
 $S_{d1} = 0.14g$   
FUNDAMENTAL PERIOD:  
E--W,  $T = 0.15s$   
N--S,  $T = 0.15s$   
GENERAL DESIGN RESPONSE SPECTRAL ACCELERATION:  
 $S_q = 0.14g$   
BASIC SEISMIC FORCE RESISTING SYSTEM:  
LIGHT FRAMED WALLS WITH SHEAR PANELS  
 $R = 6-1/2$   
 $Q = 2-1/2$   
 $C_d = 4-1/2$

**CAST IN PLACE CONCRETE**

1. ALL CONCRETE SHALL BE PORTLAND CEMENT CONCRETE WITH A MINIMUM 28 DAY COMPRESSIVE STRENGTH OF 3000 psi.
2. ALL FOUNDATIONS SHALL BEAR ON UNDISTURBED VIRGIN SOIL WITH NO VEGETATION, OR ON ENGINEERED FILL (95% MODIFIED PROCTOR)
3. SLABS ON GRADE TO INCLUDE 6 MIL POLYETHYLENE VAPOR BARRIER.
4. STRUCTURAL FOUNDATION DESIGN IS BASED UPON AN ALLOWABLE SOIL BEARING PRESSURE OF 2000 psf AND A LATERAL SOIL PRESSURE OF 200 psf. THIS MUST BE VERIFIED BY THE CONTRACTOR PRIOR TO CONSTRUCTION BY SUBSURFACE INVESTIGATION.
5. PROPORTION AND DESIGN MIXES TO RESULT IN CONCRETE SLUMP AT POINT OF PLACEMENT BETWEEN 3" AND 5". ADDITION OF WATER TO READY-MIX CONCRETE IN THE FIELD SHALL NOT BE PERMITTED.
6. SLAB POURS SHALL NOT EXCEED 50 FEET IN ANY ONE DIRECTION BETWEEN FORMED CONSTRUCTION JOINTS. CONTROL JOINTS MAY BE SAW CUT 12 - 24 HOURS AFTER PLACING CONCRETE.

**STRUCTURAL TIMBER**

1. STRUCTURAL DESIGN IS BASED ON THE USE OF #2 SOUTHERN YELLOW PINE, STRUCTURAL GRADE #2, KD - 19, WITH A MINIMUM STRENGTH AS FOLLOWS:  
POSTS:  $F_b = 850$  psi  
GIRTS/PURLINS:  $F_b = 1250$  psi
2. ALL RESIDENTIAL CONSTRUCTION SBCCI SSTD 10 - 97, UNLESS OTHERWISE SPECIFIED BY THE ENGINEER OR ARCHITECT.
3. ALL NAILING REQUIREMENTS SHALL BE AS PER STANDARD BUILDING CODE TABLE 2306.1, OR SBCCI SSTD 10 - 97, APPENDIX E, UNLESS OTHERWISE NOTED. NAILING REQUIREMENTS ARE IN ADDITION TO SPECIFIED TIMBERS.
4. ALL NAILING REQUIREMENTS LISTED ARE BASED UPON THE USE OF COMMON WIRE NAILS. ALTERNATE NAIL TYPES OF EQUIVALENT DIAMETERS MAY BE SUBSTITUTED, WITH PRIOR APPROVAL OF THE ENGINEER OF RECORD.
5. TIMBER CONNECTIONS SHALL BE MADE WITH STRUCTURAL HANGARS AS MANUFACTURED BY SIMPSON COMPANY, OR APPROVED EQUAL. ALL INSTALLATION WILL BE WITH NAIL TYPES AND SIZES AS REQUIRED BY THE MANUFACTURER TO DEVELOP FULL STRENGTH OF EACH CONNECTOR SPECIFIED.
6. TIMBER DESIGNATED AS TREATED SHALL BE PRESSURE TREATED IN ACCORDANCE WITH AWPA C2.

**PREFABRICATED WOOD ROOF TRUSSES**

1. TRUSSES TO BE SPACED AT 4' - 0" O.C. TYPICAL UNLESS OTHERWISE NOTED. SMALLER SPACING MAY BE USED IF NECESSARY. SEE PLANS FOR TRUSS LOCATIONS AND SPANS.
2. TRUSS DESIGN LOADS:  
TOP CHORD LIVE: 20 psf  
TOP CHORD DEAD: 5 psf  
BOTTOM CHORD DEAD: 1 psf  
TOTAL LOAD: 5 psf  
UPLIFT: 10 psf min.
3. TOP CHORD DEAD LOAD INCLUDES 3 psf (6 lb/ft) TRUSS SELF WEIGHT.
4. LOADS INDICATED SHALL BE USED FOR DESIGN OF HIP AND/OR GIRDER TRUSSES AS REQUIRED.
5. MAXIMUM COMBINED DEFLECTION SHALL BE  $L/240$ .
6. TRUSSES TO BE DESIGNED AND FABRICATED BY MANUFACTURER; SHOP DRAWINGS SHALL BE SIGNED AND SEALED BY A REGISTERED ENGINEER.
7. TRUSS-TO-TRUSS CONNECTORS SHALL BE DESIGNED BY TRUSS MANUFACTURER.
8. PERMANENT TRUSS BRIDGING AND TEMPORARY TRUSS BRACING SHALL BE THE RESPONSIBILITY OF THE CONTRACTOR, AND SHALL BE IN ACCORDANCE WITH TRUSS MANUFACTURER'S RECCOMENDATION.

REVIEW OF STRUCTURAL COMPONENTS ONLY AS RELATED TO N.C. STATE RESIDENTIAL BUILDING CODE, 2018 EDITION IN PARTICULAR, THE ONLY ITEMS APPLICABLE ARE CONCRETE FOOTINGS, LVL HEADERS, POSTS AND ATTACHMENTS. THOMPSON AND ASSOCIATES, PA (C-0343) 1149 EXECUTIVE CIRCLE SUITE D-2 CARY, N.C. 27511 (919) 465-1566  
SEAL ONLY APPLIES TO STRUCTURAL MEMBERS AS SHOWN ON THIS PLAN. CONSTRUCTION METHODS, PROCEDURES, TECHNIQUES, SEQUENCES AND SAFETY MEASURES ARE NOT APPLICABLE TO ENGINEERS SEAL ANY CHANGES, DISCREPANCIES, ALTERATIONS, OR OMISSIONS TO THE PLANS SHOULD BE IMMEDIATELY BE BROUGHT TO THE ATTENTION OF THOMPSON AND ASSOCIATES. FAILURE TO CONTACT THOMPSON AND ASSOCIATES WILL VOID THOMPSON AND ASSOCIATES LIABILITY. TRUSSES AND THEIR MEMBERS ARE BY OTHERS.

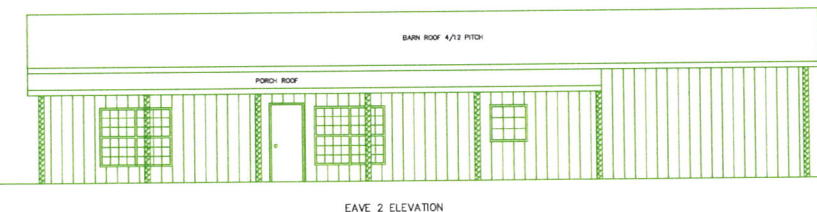
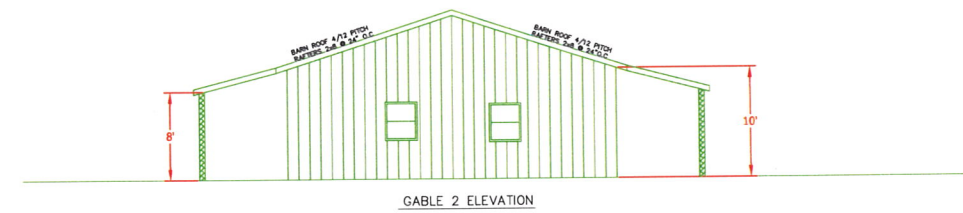
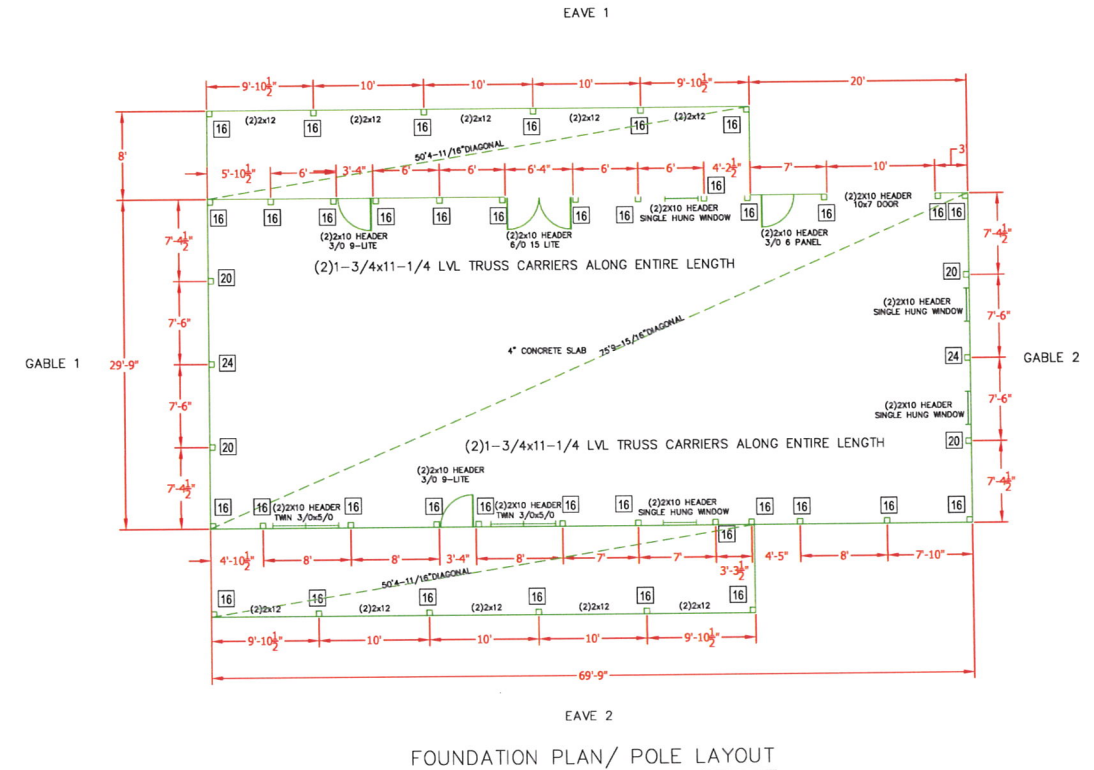

VA CAROLINA BUILDINGS  
6212 VICKY DRIVE  
RALEIGH, NC 27603

PROPOSED BUILDING PLAN FOR  
**PAUL & PAT MCCOMAS**  
1448 THOMPSON ROAD  
BUNN LEVEL, NC 28322

REVISIONS:

NO.	DATE	DESCRIPTION

ISSUED:

NO.	DATE	DESCRIPTION

DRAWN BY: MHR  
CHECKED BY: MWK

DETAILS

SHEET NO.  
**D1**



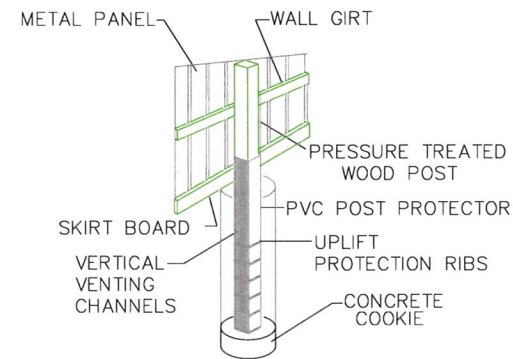

POST PROTECTOR DETAIL

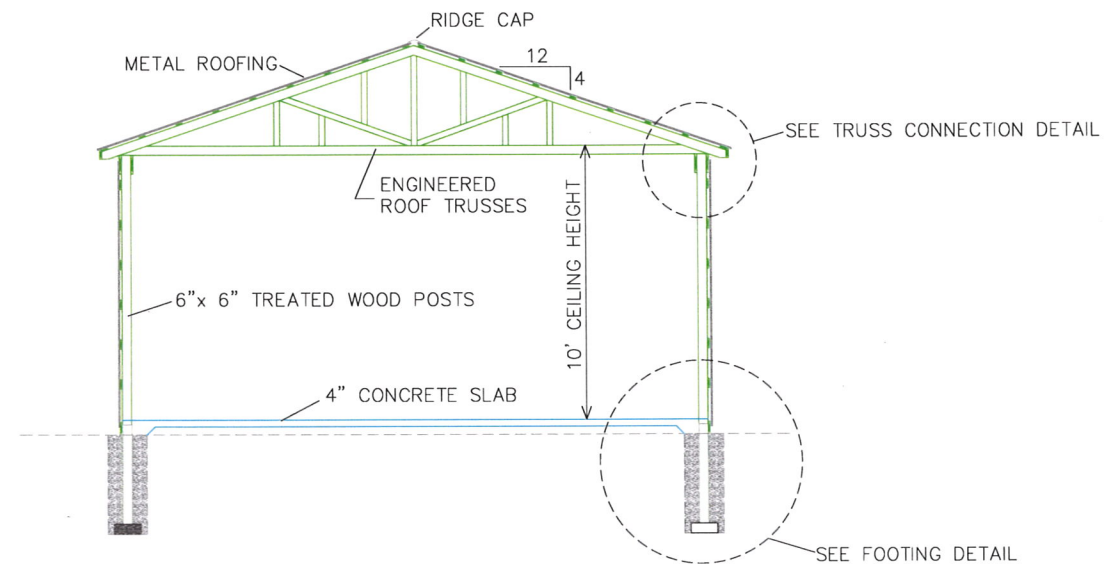

BUILDING CROSS SECTION

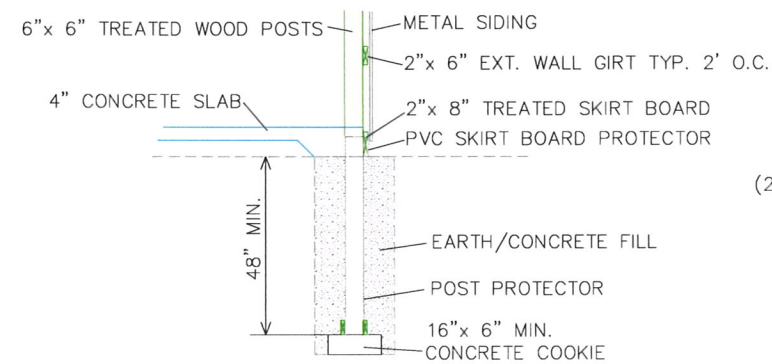

FOOTING DETAIL

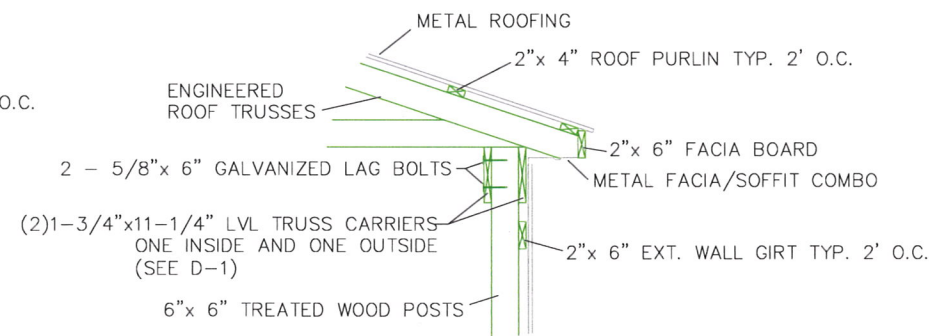

TRUSS CONNECTION DETAIL

REVIEW OF STRUCTURAL COMPONENTS ONLY AS RELATED TO N.C. STATE RESIDENTIAL BUILDING CODE, 2018 EDITION IN PARTICULAR, THE ONLY ITEMS APPLICABLE ARE CONCRETE FOOTINGS, LVL HEADERS, POSTS AND ATTACHMENTS. THOMPSON AND ASSOCIATES, PA (C-0343) 1149 EXECUTIVE CIRCLE SUITE D-2 CARY, N.C. 27511 (919) 465-1566  
 SEAL ONLY APPLIES TO STRUCTURAL MEMBERS AS SHOWN ON THIS PLAN. CONSTRUCTION METHODS, PROCEDURES, TECHNIQUES, SEQUENCES AND SAFETY MEASURES ARE NOT APPLICABLE TO ENGINEERS SEAL ANY CHANGES, DISCREPANCIES, ALTERATIONS, OR OMISSIONS TO THE PLANS SHOULD BE IMMEDIATELY BE BROUGHT TO THE ATTENTION OF THOMPSON AND ASSOCIATES. FAILURE TO CONTACT THOMPSON AND ASSOCIATES WILL VOID THOMPSON AND ASSOCIATES LIABILITY. TRUSSES AND THEIR MEMBERS ARE BY OTHERS.



VA CAROLINA BUILDINGS, LLC  
 POST AND FRAME BUILDING

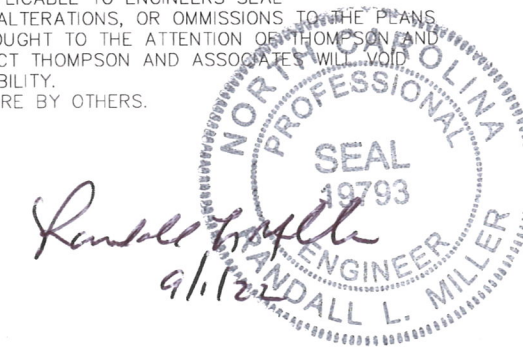

SHEET 2 OF 2

VA CAROLINA BUILDINGS  
 6212 WICKY DRIVE  
 RALEIGH, NC 27603

PROPOSED BUILDING PLAN FOR  
**PAUL & PAT MCCOMAS**  
 1448 THOMPSON ROAD  
 BUNN LEVEL, NC 28322

REVISIONS:

NO.	DATE	DESCRIPTION

ISSUED:

NO.	DATE	DESCRIPTION

DRAWN BY: MHR

CHECKED BY: MHR

DETAILS

SHEET NO.

D2