

Trenco
818 Soundside Rd
Edenton, NC 27932

Re: 4242230
E1 E3 repair letter

The truss drawing(s) referenced below have been prepared by Truss Engineering Co. under my direct supervision based on the parameters provided by Stock Building Supply.

Pages or sheets covered by this seal: T35948168 thru T35948169

My license renewal date for the state of North Carolina is December 31, 2025.

North Carolina COA: C-0844



January 2, 2025

O'Regan, Philip

IMPORTANT NOTE: The seal on these truss component designs is a certification that the engineer named is licensed in the jurisdiction(s) identified and that the designs comply with ANSI/TPI 1. These designs are based upon parameters shown (e.g., loads, supports, dimensions, shapes and design codes), which were given to MiTek or TRENCO. Any project specific information included is for MiTek's or TRENCO's customers file reference purpose only, and was not taken into account in the preparation of these designs. MiTek or TRENCO has not independently verified the applicability of the design parameters or the designs for any particular building. Before use, the building designer should verify applicability of design parameters and properly incorporate these designs into the overall building design per ANSI/TPI 1, Chapter 2.

Job 4242230	Truss E3	Truss Type Attic Girder	Qty 1	Ply 1+1	E1 E3 repair letter Job Reference (optional)	Units: 1.0 Eng: T.L	T35948169
----------------	-------------	----------------------------	----------	------------	---	------------------------	-----------

Builders FirstSource (Middlesex, NC), Middlesex, NC - 27557,

Run: 8.63 S Sep 26 2024 Print: 8.630 S Sep 26 2024 MiTek Industries, Inc. Thu Jan 02 10:34:33

Page: (1 of 3)

ID:fSSmZx4VBHu7Tndprj1AG?yc7Uo-RfC?PsB70Hq3NSgPqnL8w3uITxbGKWrCdoi7J4zJC?f

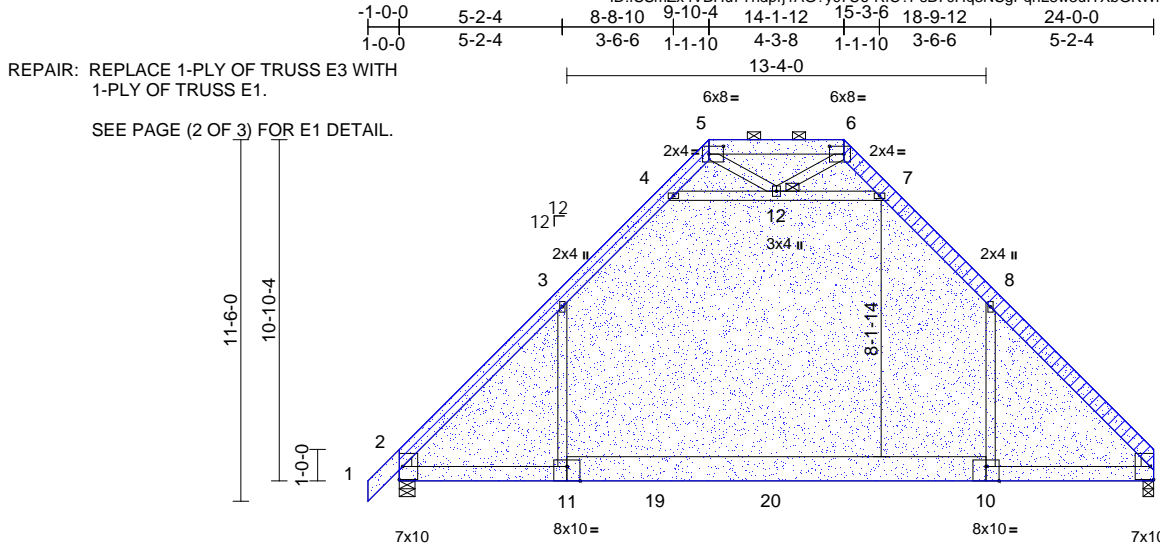

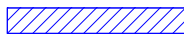
 APPLY 2 X 6 SP NO.2 SCAB TO ONE FACE OF TRUSS OPPOSITE OF E1 AS SHOWN. ATTACH WITH (0.131" X 3") NAILS PER THE FOLLOWING NAIL SCHEDULE: 2 x 6'S - 2 ROW: SPACED @ 6" O.C. USE 2" MEMBER END DISTANCE.

 ATTACH E1 TRUSS TO ONE FACE OF (1-PLY) E3 TRUSS WITH (0.131" X 3") NAILS (INTO ALL ALIGNING MEMBERS) PER THE FOLLOWING NAIL SCHEDULE: 2 x 4'S - 2 ROWS, 2 x 6'S AND LARGER - 3 ROWS: SPACED @ 6" O.C. USE 2" MEMBER END DISTANCE.

Scale = 1:73.3

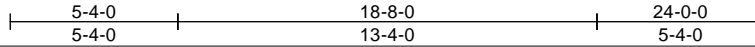

Plate Offsets (X, Y): [5:0-5-8,0-3-0], [6:0-5-8,0-3-0], [10:0-5-0,Edge], [11:0-5-0,Edge]

Loading	(psf)	Spacing	2-0-0	CSI	DEFL	in (loc)	l/defl	L/d	PLATES	GRIP		
TCLL (roof)	20.0	Plate Grip DOL	1.00	TC	0.66	Vert(LL)	-0.21	10-11	>999	240	MT20	244/190
TCDL	10.0	Lumber DOL	1.15	BC	0.97	Vert(CT)	-0.59	10-11	>491	180		
BCLL	0.0*	Rep Stress Incr	NO	WB	0.40	Horz(CT)	0.03	2	n/a	n/a		
BCDL	10.0	Code	IRC2015/TPI2014	Matrix-MS		Attic	-0.12	10-11	>999	360	Weight: 384 lb	FT = 20%

LUMBER
TOP CHORD 2x6 SP 2400F 2.0E or 2x6 SP DSS *Except* 5-6:2x6 SP No.2
BOT CHORD 2x6 SP No.2 *Except* 11-10:2x10 SP 2400F 2.0E or 2x10 SP DSS
WEBS 2x4 SP No.3
WEDGE Left: 2x4 SP No.3
Right: 2x4 SP No.3

BRACING
TOP CHORD Structural wood sheathing directly applied or 6-0-0 oc purlins, except 2-0-0 oc purlins (10-0-0 max.): 5-6.
BOT CHORD Rigid ceiling directly applied or 10-0-0 oc bracing.
JOINTS 1 Brace at Jt(s): 12

REACTIONS (size) 2=0-6-0, 9=0-4-0
Max Horiz 2=216 (LC 5)
Max Grav 2=2126 (LC 2), 9=1873 (LC 2)

FORCES (lb) - Maximum Compression/Maximum Tension
TOP CHORD 1-2=0/42, 2-3=-2572/0, 3-4=-1320/0, 4-5=0/770, 5-6=0/1176, 6-7=0/790, 7-8=-1361/0, 8-9=-2529/169
BOT CHORD 2-9=0/1531
WEBS 3-11=0/1686, 8-10=0/1567, 4-12=-2649/0, 7-12=-2736/0, 5-12=-99/85, 6-12=0/196

NOTES
1) n/a

- All loads are considered equally applied to all plies, except if noted as front (F) or back (B) face in the LOAD CASE(S) section. Ply to ply connections have been provided to distribute to plies noted as (F) or (B), unless otherwise indicated.
- Unbalanced roof live loads have been considered for this design.
- Wind: ASCE 7-10; Vult=118mph (3-second gust) Vasd=93mph; TCDL=6.0psf; BCDL=6.0psf; h=30ft; Cat. II; Exp B; Enclosed; MWFRS (envelope) exterior zone; cantilever left and right exposed; end vertical left and right exposed; Lumber DOL=1.60 plate grip DOL=1.33
- Provide adequate drainage to prevent water ponding.
- This truss has been designed for a 10.0 psf bottom chord live load nonconcurrent with any other live loads.
- * This truss has been designed for a live load of 20.0psf on the bottom chord in all areas where a rectangle 3-06-00 tall by 2-00-00 wide will fit between the bottom chord and any other members.
- Ceiling dead load (5.0 psf) on member(s). 3-4, 7-8, 4-12, 7-12
- Bottom chord live load (40.0 psf) and additional bottom chord dead load (5.0 psf) applied only to room. 10-11
- All bearings are assumed to be SP No.2 crushing capacity of 565 psi.
- Load case(s) 1 has/have been modified. Building designer must review loads to verify that they are correct for the intended use of this truss.
- Graphical purlin representation does not depict the size or the orientation of the purlin along the top and/or bottom chord.
- Attic room checked for L/360 deflection.

LOAD CASE(S) Standard
1) Dead + Roof Live (balanced): Lumber Increase=1.15, Plate Increase=1.00
Uniform Loads (lb/ft)
Vert: 1-3=-60, 3-4=-70, 4-5=-60, 5-6=-60, 6-7=-60, 7-8=-70, 8-9=-60, 11-13=-20, 10-11=-30, 10-16=-20, 4-12=-10, 7-12=-10
Concentrated Loads (lb)
Vert: 19=-600, 20=-600



January 2, 2025

WARNING - Verify design parameters and READ NOTES ON THIS AND INCLUDED MITEK REFERENCE PAGE MII-7473 rev. 1/2/2023 BEFORE USE.

Design valid for use only with MiTek® connectors. This design is based only upon parameters shown, and is for an individual building component, not a truss system. Before use, the building designer must verify the applicability of design parameters and properly incorporate this design into the overall building design. Bracing indicated is to prevent buckling of individual truss web and/or chord members only. Additional temporary and permanent bracing is always required for stability and to prevent collapse with possible personal injury and property damage. For general guidance regarding the fabrication, storage, delivery, erection and bracing of trusses and truss systems, see **ANSI/TPH Quality Criteria and DSB-22** available from Truss Plate Institute (www.tpinst.org) and **BCSI Building Component Safety Information** available from the Structural Building Component Association (www.sbcacomponents.com)



818 Soundside Road
Edenton, NC 27932

Job 4242230	Truss E1	Truss Type Attic Girder	Qty 1	Ply 1	E1 E3 repair letter Job Reference (optional)	Units: 1.0 Eng: T.L	T35948169
----------------	-------------	----------------------------	----------	----------	---	------------------------	-----------

Builders FirstSource (Middlesex, NC), Middlesex, NC - 27557,

Run: 8.63 S Sep 26 2024 Print: 8.630 S Sep 26 2024 MiTek Industries, Inc. Thu Jan 02 10:34:33
ID:fSSmZx4VBHu7Tndprj1AG?yc7Uo-RfC?PsB70Hq3NSgPqnL8w3uITxbGkWrCDoi7J4zJC?f

Page: (2 of 3)

REPAIR: REMOVE RIGHT END OVERHANG.

ATTACH THIS TRUSS TO E3 ON
PAGE (1 OF 3) TO FORM A 2-PLY TRUSS.

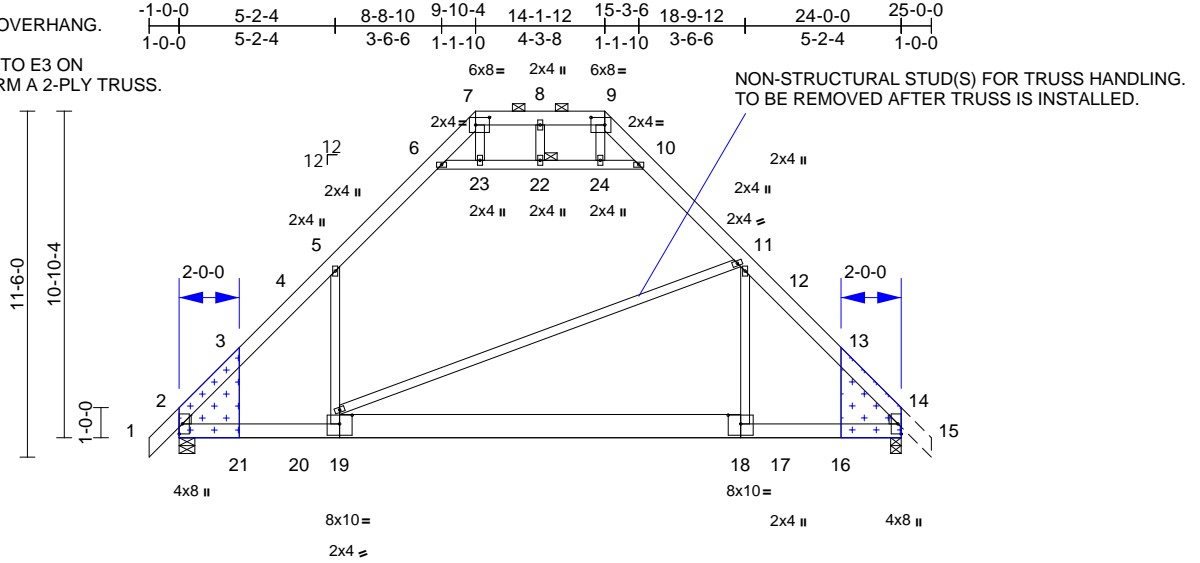

LUMBER (SHOWN DASHED) TO BE
CUT CLEANLY AND ACCURATELY AND PLATE(S)
MUST BE FULLY EMBEDDED AND UNDISTURBED.



ATTACH 1/2" PLYWOOD OR OSB GUSSET (15/32" RATED SHEATHING 32/16 EXP 1) TO
ONE FACE OF TRUSS OPPOSITE OF E1 WITH (0.113" X 2") NAILS PER THE FOLLOWING NAIL SCHEDULE:
2 X 6'S - 3 ROWS: SPACED @ 2" O.C. INTO EACH COVERED TRUSS MEMBER. USE 2" MEMBER END DISTANCE.

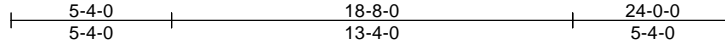

LUMBER

TOP CHORD 2x6 SP No.2
BOT CHORD 2x6 SP No.2 *Except* 19-18:2x10 SP 2400F
2.0E or 2x10 SP DSS
WEBS 2x4 SP No.3 *Except* 19-11:2x4 SP No.2
OTHERS 2x4 SP No.3
WEDGE Left: 2x4 SP No.3
Right: 2x4 SP No.3

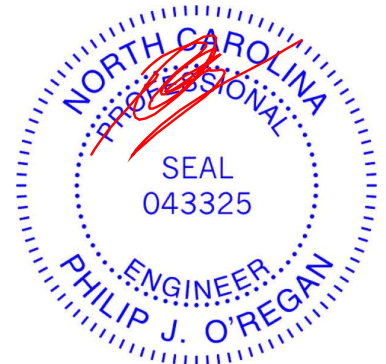

January 2, 2025

WARNING - Verify design parameters and READ NOTES ON THIS AND INCLUDED MITEK REFERENCE PAGE MII-7473 rev. 1/2/2023 BEFORE USE.

Design valid for use only with MiTek® connectors. This design is based only upon parameters shown, and is for an individual building component, not a truss system. Before use, the building designer must verify the applicability of design parameters and properly incorporate this design into the overall building design. Bracing indicated is to prevent buckling of individual truss web and/or chord members only. Additional temporary and permanent bracing is always required for stability and to prevent collapse with possible personal injury and property damage. For general guidance regarding the fabrication, storage, delivery, erection and bracing of trusses and truss systems, see **ANSI/TPH Quality Criteria and DSB-22** available from Truss Plate Institute (www.tpinst.org) and **BCSI Building Component Safety Information** available from the Structural Building Component Association (www.sbcacomponents.com)

ENGINEERING BY
TRENCO
A MiTek Affiliate

818 Soundside Road
Edenton, NC 27932

Job 4242230	Truss E3	Truss Type Attic Girder	Qty 1	Ply 1	E1 E3 repair letter Job Reference (optional)	Units: 1.0 Eng: T.L	T35948169
----------------	-------------	----------------------------	----------	----------	---	------------------------	-----------

Builders FirstSource (Middlesex, NC), Middlesex, NC - 27557,

Run: 8.63 S Sep 26 2024 Print: 8.630 S Sep 26 2024 MiTek Industries, Inc. Thu Jan 02 10:34:33

Page: (3 of 3)

ID:fSSmZx4VBHu7Tndprj1AG?yc7Uo-RfC?PsB70Hq3NSgPqnL8w3uITXbGKWrCDoi7J4zJC?f

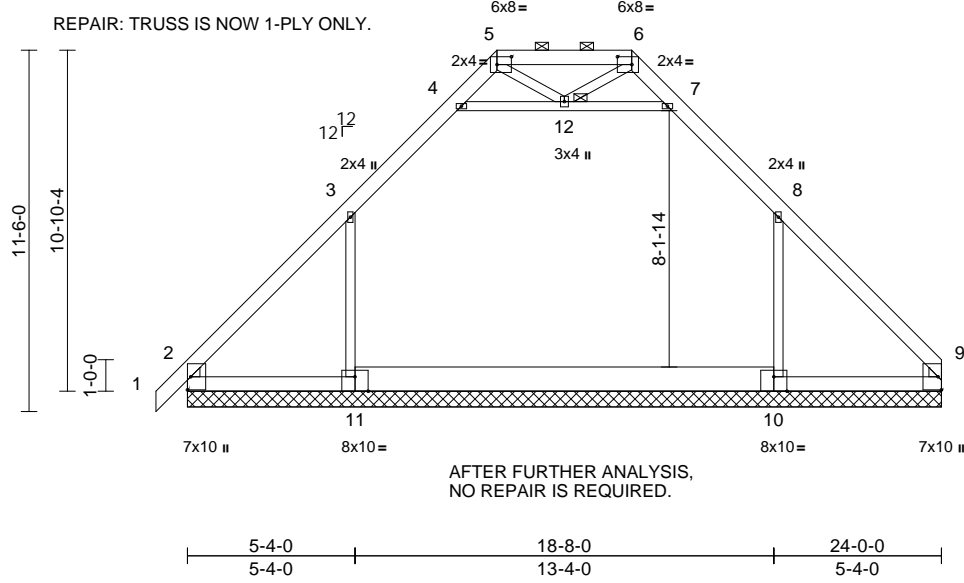
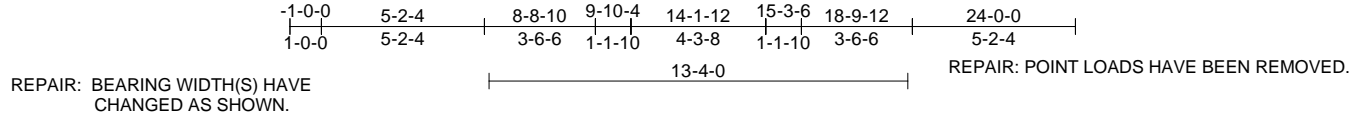

Scale = 1:73.3

Plate Offsets (X, Y): [5:0-5-8,0-3-0], [6:0-5-8,0-3-0], [10:0-5-0,Edge], [11:0-5-0,Edge]

Loading	(psf)	Spacing	2-0-0	CSI	DEFL	in	(loc)	l/defl	L/d	PLATES	GRIP	
TCLL (roof)	20.0	Plate Grip DOL	1.00	TC	0.39	Vert(LL)	n/a	-	n/a	999	MT20	244/190
TCDL	10.0	Lumber DOL	1.15	BC	0.77	Vert(CT)	n/a	-	n/a	999		
BCLL	0.0*	Rep Stress Incr	NO	WB	0.43	Horz(CT)	0.03	9	n/a	n/a		
BCDL	10.0	Code	IRC2015/TPI2014	Matrix-MS							Weight: 192 lb	FT = 20%

LUMBER
TOP CHORD 2x6 SP 2400F 2.0E or 2x6 SP DSS *Except* 5-6:2x6 SP No.2
BOT CHORD 2x6 SP No.2 *Except* 11-10:2x10 SP 2400F 2.0E or 2x10 SP DSS
WEBS 2x4 SP No.3
WEDGE Left: 2x4 SP No.3
Right: 2x4 SP No.3

BRACING
TOP CHORD Structural wood sheathing directly applied or 6-0-0 oc purlins, except 2-0-0 oc purlins (6-0-0 max.): 5-6.
BOT CHORD Rigid ceiling directly applied or 6-0-0 oc bracing.

JOINTS
1 Brace at Jt(s): 12

REACTIONS
All bearings 24-0-0.
(lb) - Max Horiz 2=216 (LC 5), 13=216 (LC 5)
Max Uplift All uplift 100 (lb) or less at joint(s) 9, 19 except 2=-103 (LC 4), 11=-125 (LC 8), 13=-103 (LC 4)
Max Grav All reactions 250 (lb) or less at joint (s) 2, 9, 13, 19 except 10=1175 (LC 17), 11=1093 (LC 16)

FORCES
(lb) - Max. Comp./Max. Ten. - All forces 250 (lb) or less except when shown.
TOP CHORD 3-4=-351/119, 4-5=-557/57, 5-6=-583/24, 6-7=-547/42, 7-8=-359/91
WEBS 3-11=-688/216, 8-10=-751/125, 4-12=-56/564, 7-12=0/520

- Gable requires continuous bottom chord bearing.
 - This truss has been designed for a 10.0 psf bottom chord live load nonconcurrent with any other live loads.
 - * This truss has been designed for a live load of 20.0psf on the bottom chord in all areas where a rectangle 3-06-00 tall by 2-00-00 wide will fit between the bottom chord and any other members, with BCDL = 10.0psf.
 - Ceiling dead load (5.0 psf) on member(s). 3-4, 7-8, 4-12, 7-12
 - Provide mechanical connection (by others) of truss to bearing plate capable of withstanding 100 lb uplift at joint(s) 9, 9 except (jt=lb) 2=103, 11=125, 2=103.
 - Graphical purlin representation does not depict the size or the orientation of the purlin along the top and/or bottom chord.
 - Attic room checked for L/360 deflection.
- LOAD CASE(S)** Standard

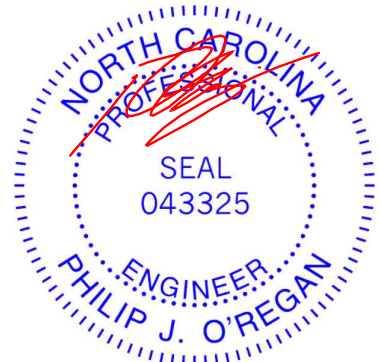

January 2, 2025

- NOTES**
- Unbalanced roof live loads have been considered for this design.
 - Wind: ASCE 7-10; Vult=118mph (3-second gust) Vasd=93mph; TC DL=6.0psf; BCDL=6.0psf; h=30ft; Cat. II; Exp B; Enclosed; MWFRS (envelope) exterior zone; cantilever left and right exposed; end vertical left and right exposed; Lumber DOL=1.60 plate grip DOL=1.33
 - Provide adequate drainage to prevent water ponding.

WARNING - Verify design parameters and READ NOTES ON THIS AND INCLUDED MITEK REFERENCE PAGE MII-7473 rev. 1/2/2023 BEFORE USE.

Design valid for use only with MiTek® connectors. This design is based only upon parameters shown, and is for an individual building component, not a truss system. Before use, the building designer must verify the applicability of design parameters and properly incorporate this design into the overall building design. Bracing indicated is to prevent buckling of individual truss web and/or chord members only. Additional temporary and permanent bracing is always required for stability and to prevent collapse with possible personal injury and property damage. For general guidance regarding the fabrication, storage, delivery, erection and bracing of trusses and truss systems, see **ANSI/TPH Quality Criteria and DSB-22** available from Truss Plate Institute (www.tpinst.org) and **BCSI Building Component Safety Information** available from the Structural Building Component Association (www.sbcacomponents.com)



818 Soundside Road
Edenton, NC 27932

Symbols

PLATE LOCATION AND ORIENTATION

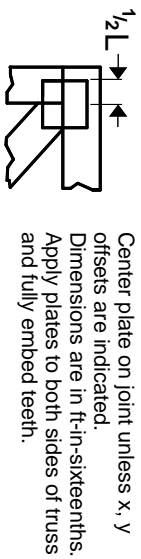

Center plate on joint unless x, y offsets are indicated. Dimensions are in ft-in-sixteenths. Apply plates to both sides of truss and fully embed teeth.

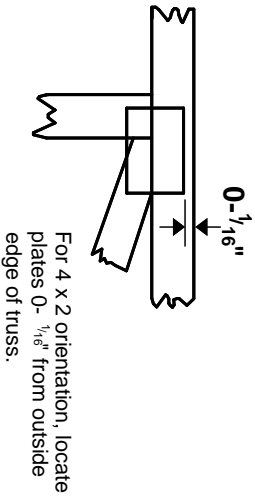

For 4 x 2 orientation, locate plates 0- 1/16\" from outside edge of truss.

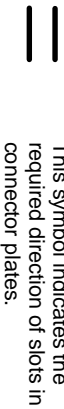

This symbol indicates the required direction of slots in connector plates.

* Plate location details available in MITek software or upon request.

PLATE SIZE

4 X 4
The first dimension is the plate width measured perpendicular to slots. Second dimension is the length parallel to slots.

LATERAL BRACING LOCATION

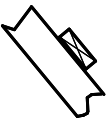

Indicated by symbol shown and/or by text in the bracing section of the output. Use T or I bracing if indicated.

BEARING

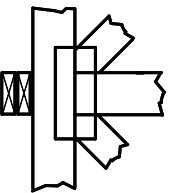

Indicates location where bearings (supports) occur. Icons vary but reaction section indicates joint number/letter where bearings occur. Min size shown is for crushing only.

Industry Standards:

ANSI/TP1: National Design Specification for Metal Plate Connected Wood Truss Construction.
DSB-22: Design Standard for Bracing.
BCSI: Building Component Safety Information, Guide to Good Practice for Handling, Installing, Restraining & Bracing of Metal Plate Connected Wood Trusses.

Numbering System

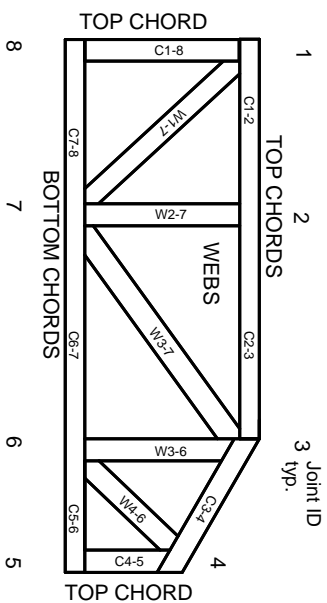

JOINTS ARE GENERALLY NUMBERED/LETTERED CLOCKWISE AROUND THE TRUSS STARTING AT THE JOINT FARTHEST TO THE LEFT.

CHORDS AND WEBS ARE IDENTIFIED BY END JOINT NUMBERS/LETTERS.

Product Code Approvals

ICC-ES Reports:

ESR-1988, ESR-2362, ESR-2685, ESR-3282
ESR-4722, ESL-1388

Design General Notes

Trusses are designed for wind loads in the plane of the truss unless otherwise shown.

Lumber design values are in accordance with ANSI/TP1 section 6.3. These truss designs rely on Lumber values established by others.

© 2023 MITek® All Rights Reserved

MITek

ENGINEERING BY
TRENGO
A MITek Affiliate

MITek Engineering Reference Sheet: MIL-7473 rev. 1/2/2023

General Safety Notes

Failure to Follow Could Cause Property Damage or Personal Injury

1. Additional stability/bracing for truss system, e.g. diagonal or X-bracing, is always required. See BCSI.
2. Truss bracing must be designed by an engineer. For wide truss spacing, individual lateral braces themselves may require bracing, or alternative Tor I bracing should be considered.
3. Never exceed the design loading shown and never stack materials on inadequately braced trusses.
4. Provide copies of this truss design to the building designer, erection supervisor, property owner and all other interested parties.
5. Cut members to bear tightly against each other.
6. Place plates on each face of truss at each joint and embed fully. Knots and wane at joint locations are regulated by ANSI/TP1 1.
7. Design assumes trusses will be suitably protected from the environment in accord with ANSI/TP1 1.
8. Unless otherwise noted, moisture content of lumber shall not exceed 19% at time of fabrication.
9. Unless expressly noted, this design is not applicable for use with fire retardant, preservative treated, or green lumber.
10. Camber is a non-structural consideration and is the responsibility of truss fabricator. General practice is to camber for dead load deflection.
11. Plate type, size, orientation and location dimensions indicated are minimum plating requirements.
12. Lumber used shall be of the species and size, and in all respects, equal to or better than that specified.
13. Top chords must be sheathed or purlins provided at spacing indicated on design.
14. Bottom chords require lateral bracing at 10 ft. spacing, or less, if no ceiling is installed, unless otherwise noted.
15. Connections not shown are the responsibility of others.
16. Do not cut or alter truss member or plate without prior approval of an engineer.
17. Install and load vertically unless indicated otherwise.
18. Use of green or treated lumber may pose unacceptable environmental, health or performance risks. Consult with project engineer before use.
19. Review all portions of this design (front, back, words and pictures) before use. Reviewing pictures alone is not sufficient.
20. Design assumes manufacture in accordance with ANSI/TP1 1 Quality Criteria.
21. The design does not take into account any dynamic or other loads other than those expressly stated.