



Application # _____

Harnett County Central Permitting
420 McKinney Pkwy Lillington, NC 27546
PO Box 65 Lillington, NC 27546

910-893-7525 ext. 1 Fax 910-893-2793 www.harnett.org/permits

* Must be owner/occupier or licensed contractor. Address, company name & phone must match information on license.

Application for Residential Building and Trades Permit

Owner's Name: JLT Managing Properties Date _____
Site Address: 107 Twin City St. Erwin, NC Phone 919-980-2009
Subdivision: _____ Lot _____
Description of Proposed Work: New SFD Total Job Cost 1

General Contractor Information

JLT Managing Properties 919-980-2009
Building Contractor's Company Name Telephone
306 S. Wall St. Benson, NC jltmanagingproperties@gmail.com
Address Email Address
79495 **HEATED SQ FT 1120** **GARAGE SQ FT N/A**
License #

Electrical Contractor Information

Description of Work New Dwelling Service Size: 200 Amps T-Pole: Yes No
Jason Pope 919-820-0837
Electrical Contractor's Company Name Telephone
81 Beaver Creek Dr. Dunn, NC _____
Address Email Address
29284
License #

Mechanical/HVAC Contractor Information

Description of Work New Dwelling
Bandy Jackson 910-242-2941
Mechanical Contractor's Company Name Telephone
100 N. 13th St. Erwin, NC _____
Address Email Address
18512
License #

Plumbing Contractor Information

Description of Work New Dwelling # Baths 2
Brandon Hardison 919-820-1434
Plumbing Contractor's Company Name Telephone
P.O. Box 45 Benson, NC _____
Address Email Address
34260
License #

Insulation Contractor Information

TW-City 919-422-9900
Insulation Contractor's Company Name & Address Telephone

***NOTE: General Contractor / owner must fill out and sign the second page of this application.**



I hereby certify that I have the authority to make necessary application, that the application is correct and that the construction will conform to the regulations in the Building, Electrical, Plumbing and Mechanical codes, and the Harnett County Zoning Ordinance. I state the information on the above contractors is correct as known to me and that **by signing below I have obtained all subcontractors permission to obtain these permits** and if **any** changes occur including listed contractors, site plan, number of bedrooms, building and trade plans, Environmental Health permit changes or proposed use changes, I certify it is my responsibility to notify the Harnett County Central Permitting Department of any and all changes.

EXPIRED PERMIT FEES - 6 Months to 2 years permit re-issue fee is \$150.00. After 2 years re-issue fee is as per current fee schedule.

Signature of Owner/Contractor/Officer(s) of Corporation

Date 6/16/22

Affidavit for Worker's Compensation N.C.G.S. 87-14

The undersigned applicant being the:

General Contractor Owner Officer/Agent of the Contractor or Owner

Do hereby confirm under penalties of perjury that the person(s), firm(s) or corporation(s) performing the work set forth in the permit:

Has three (3) or more employees and has obtained workers' compensation insurance to cover them.

Has one (1) or more subcontractors(s) and has obtained workers' compensation insurance to cover them.

Has one (1) or more subcontractors(s) who has their own policy of workers' compensation insurance covering themselves.

Has no more than two (2) employees and no subcontractors.

While working on the project for which this permit is sought it is understood that the Central Permitting Department issuing the permit may require certificates of coverage of worker's compensation insurance prior to issuance of the permit and at any time during the permitted work from any person, firm or corporation carrying out the work.

Sign w/Title: President Date: 6/16/22

DO NOT REMOVE!

Details: Appointment of Lien Agent
Entry #: 1720304

Filed on: 06/20/2022
Initially filed by: rblackmonjrt

Designated Lien Agent

Fidelity National Title Company, LLC

Online: www.liensnc.com (<http://www.liensnc.com>)

Address: 223 S. West Street, Suite 900 /
Raleigh, NC 27603

Phone: 888-690-7384

Fax: 913-489-5231

Email: support@liensnc.com (<mailto:support@liensnc.com>)

Project Property

107 Twin City Street
Ewin, NC 28339
Harnett County

Property Type

1-2 Family Dwelling

Print & Post



Contractors:

Please post this notice on the Job Site.

Suppliers and Subcontractors:

Scan this image with your smart phone to view this filing. You can then file a Notice to Lien Agent for this project.

Owner Information

jrt managing properties
108 N. Orange Ave
Dunn, NC 28334
United States
Email: jrtmanagingproperties@gmail.com
Phone: 919-980-1096

Date of First Furnishing

07/01/2022

View Comments (0)

Technical Support Hotline: (888) 690-7384

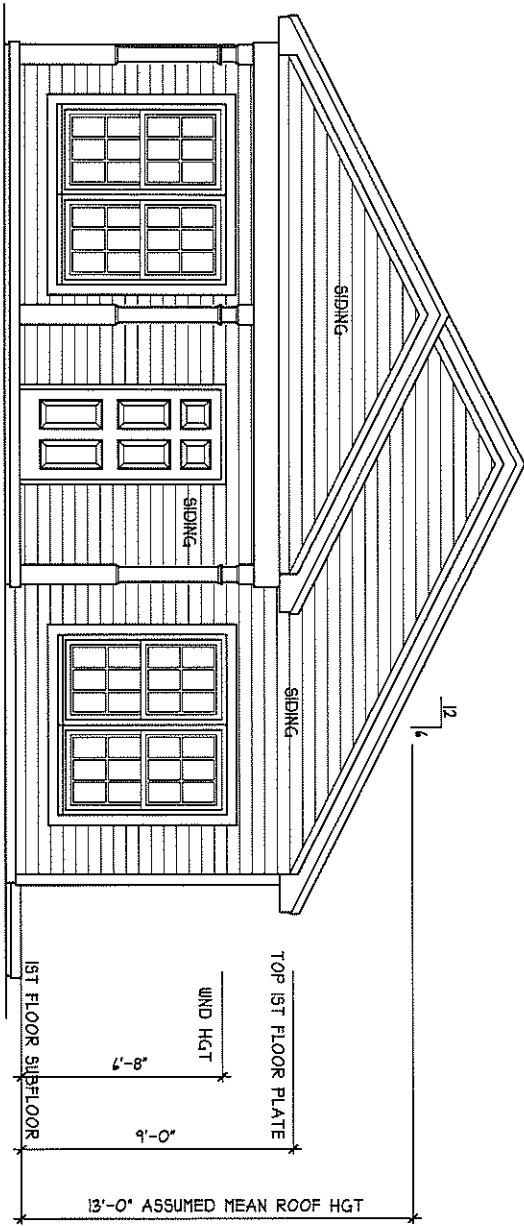
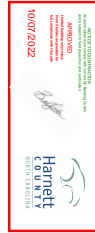

FRONT ELEVATION
SCALE 1/8" = 1'-0"

ENERGY COMPLIANCE
 ZONE 3A = MAX. GLAZING U-FACTOR .35
 R-VALUE = CEILING R38, WALLS R15,
 FLOORS R19
 ZONE 4A = MAX. GLAZING U-FACTOR .35
 R-VALUE = CEILING R38, WALLS R15,
 FLOORS R19

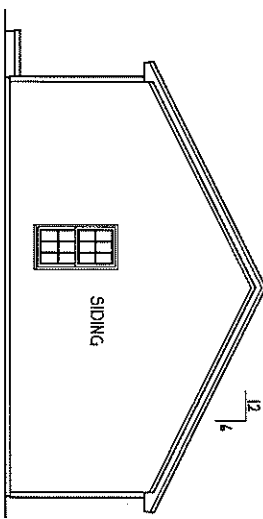

REAR ELEVATION
SCALE 1/8" = 1'-0"

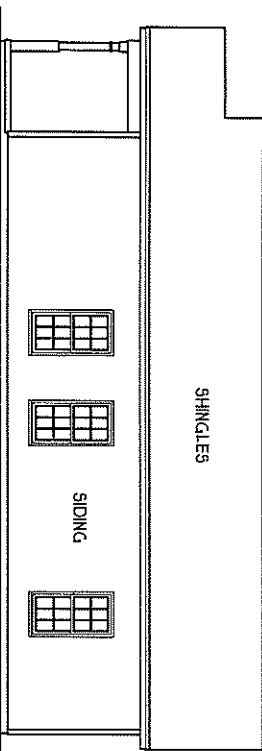

LEFT ELEVATION
SCALE 1/8" = 1'-0"

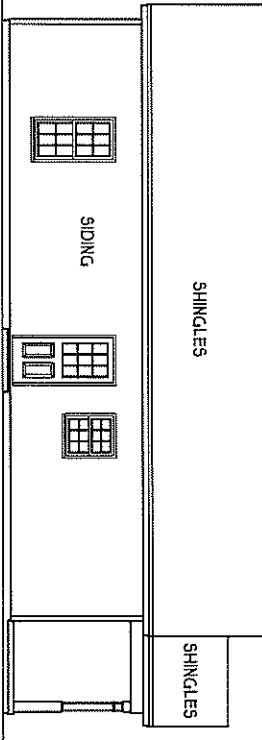

RIGHT ELEVATION
SCALE 1/8" = 1'-0"

ATTIC VENTILATION:

THE NET FREE VENTILATING AREA SHALL BE NOT LESS THAN 1 TO 150 OF THE AREA OF THE SPACE VENTILATED EXCEPT THAT THE AREA MAY BE 1 TO 300 PROVIDED EXCEPT THAT PERCENT OF THE REQUIRED AREA IN THE AREAS PROVIDED ON THE DESIGNATED ATTIC IN THE UPPER PORTION OF THE SPACE TO BE VENTILATED AT LEAST 3 FEET ABOVE EAVE OR CORNICE VENTS WITH THE BALANCE OF THE REQUIRED VENTILATION TO BE PROVIDED BY EAVE OR CORNICE VENTS.
 GROSS ATTIC AREA TO BE VENTILATED 1228 SQ.FT.
 1228/150 = 818 SQ.FT. NET FREE AREA

DATE: 12/01/2021 ANY DEVIATION OF THE SPECIFIED REQUIREMENTS IS THE RESPONSIBILITY OF THE CLIENT AND/OR ARCHITECT. THIS PLAN HAS BEEN DRAWN IN ACCORDANCE WITH NORTH CAROLINA STATE BUILDING REGULATIONS.	H SQUARED HOME DESIGN, INC. HEATHER HALL 185 HEATHERSTONE CT BENSON NC 27504 (919) 207-4003	SQUARE FOOTAGE: FIRST FLOOR = 1220 FRONT PORCH = 108	HEATED FOOTAGE: #1120	THE BENTLEY LEFT HAND JRT MANG. PROP.
		FILE NO: 070821	STORY: 1 STORY	

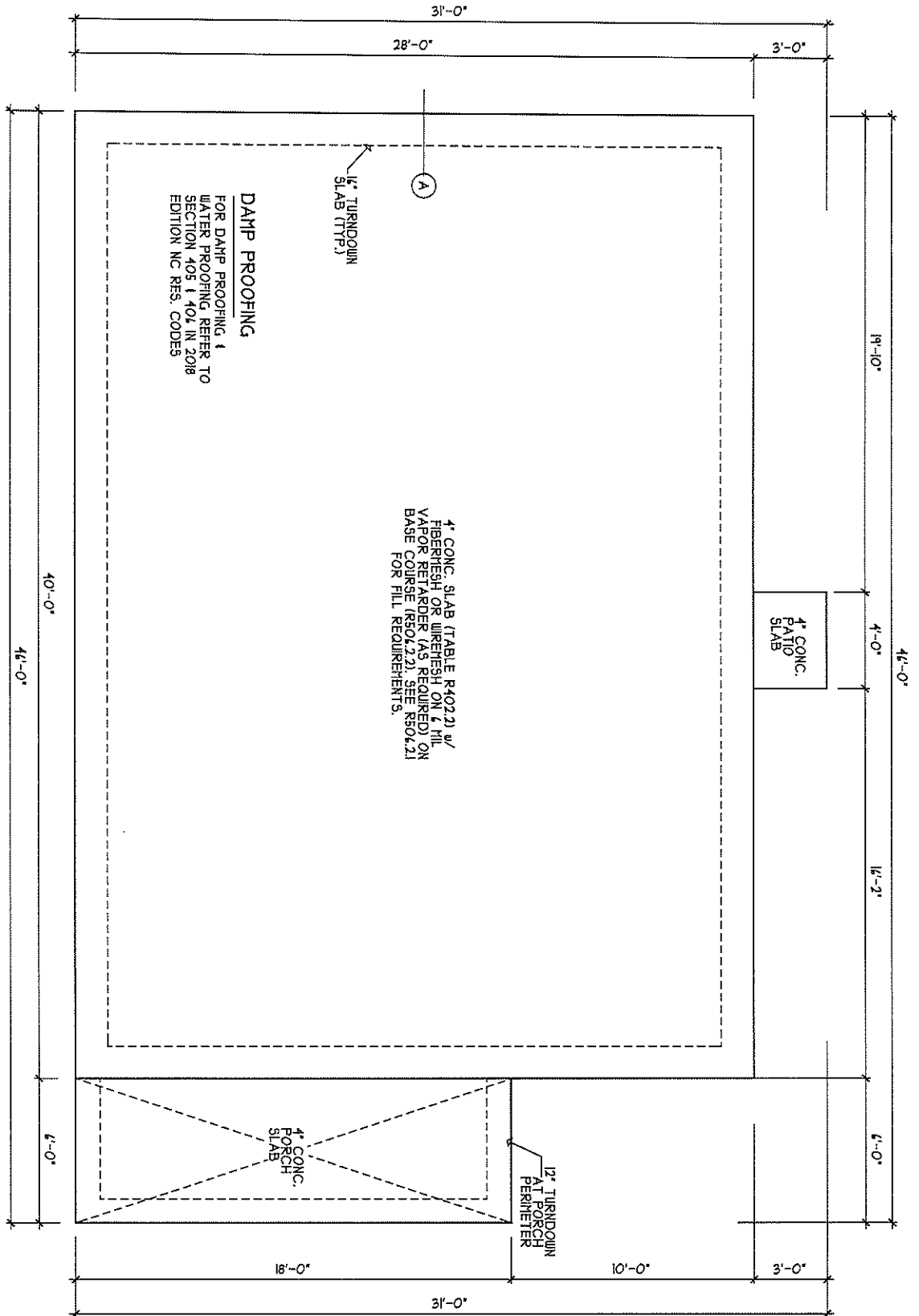

NOTE ASSUMED SOIL BEARING CAPACITY = 2000 PSF CONTRACTOR MUST VERIFY SITE CONDITIONS AND CONTACT SOILS ENGINEER IF MARGINAL OR UNSTABLE SOILS ARE ENCOUNTERED

REFER TO BASIC DETAIL SHEETS(S) FOR STANDARD DETAILS, BRACING DETAILS, AND STRUCTURAL NOTES

MONOLITHIC SLAB FOUNDATION PLAN
SCALE 1/4" = 1'-0"

DATE	12/02/2024
REVISION	1. 12/02/2024: INITIAL DESIGN
NO.	070821
STORY	1 STORY

H SQUARED HOME DESIGN, INC.

HEATHER HALL
185 HEATHERSTONE CT
BENSON NC 27504
(919) 207-1403

SQUARE FOOTAGE:	
FIRST FLOOR	= 120
FRONT PORCH	= 108

HEATED FOOTAGE:
#1120



THE BENTLEY
LEFT HAND
JRT MANG. PROP.

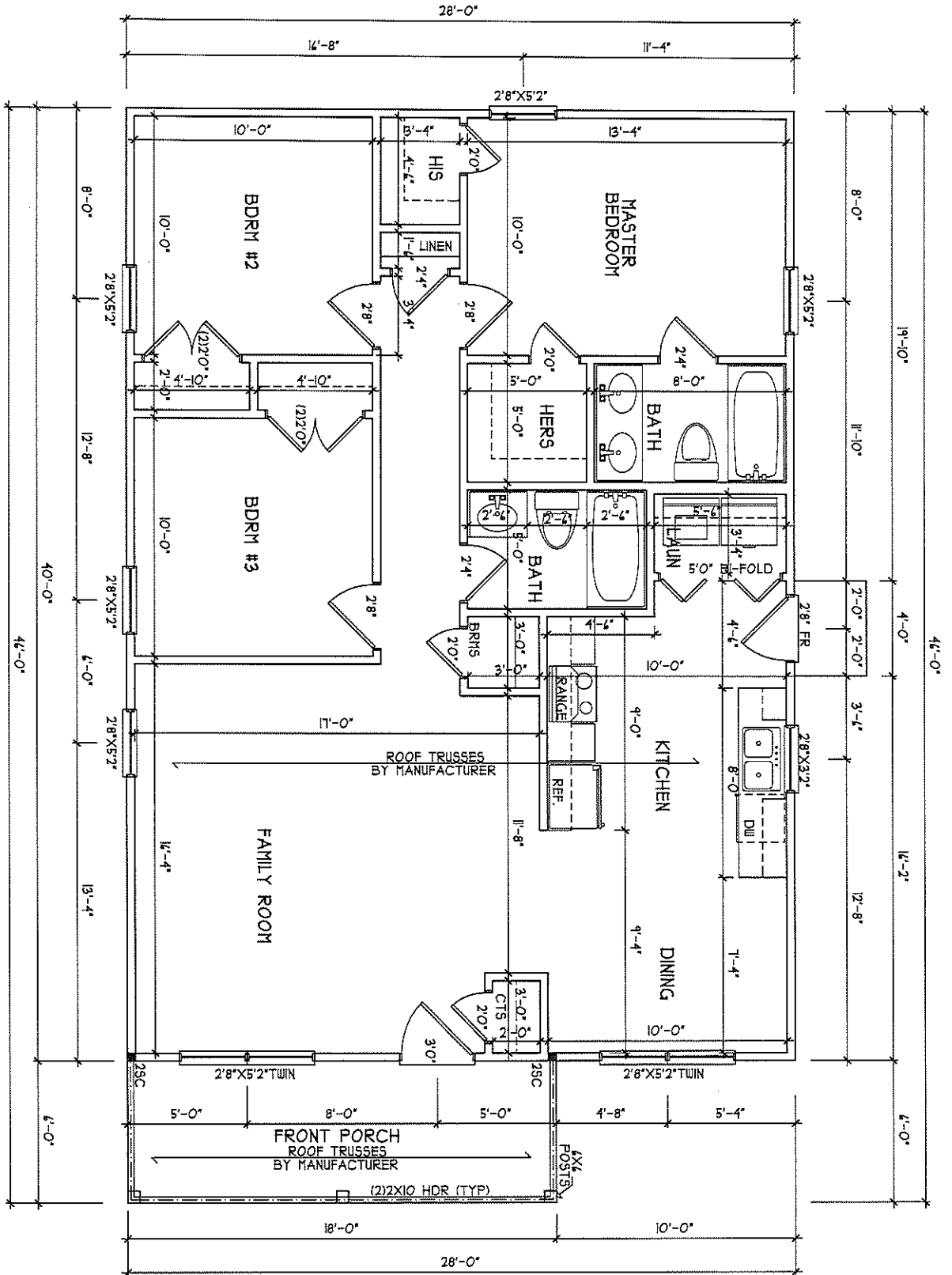



REFER TO BASIC DETAIL SHEETS (S) FOR STANDARD DETAILS, BRACING DETAILS, AND STRUCTURAL NOTES

FIRST FLOOR PLAN
SCALE 1/4" = 1'-0"

 H SQUARED HOME DESIGN, INC.	HEATHER HALL 185 HEATHERSTONE CT BENSON NC 27504 (919) 207-403	SQUARE FOOTAGE: FIRST FLOOR = 1220 FRONT PORCH = 108	HEATED FOOTAGE: #1120	THE BENTLEY LEFT HAND JRT MANG. PROP.
	DATE: 12/01/2023 ANY CHANGES TO THE DRAWING MUST BE MADE BY THE ARCHITECT OR HIS DESIGNER. THE ARCHITECT OR HIS DESIGNER SHALL BE RESPONSIBLE FOR THE ACCURACY OF THE INFORMATION PROVIDED HEREON. THIS PLAN HAS BEEN PREPARED FOR THE EXCLUSIVE USE OF THE CLIENT AND IS NOT TO BE REPRODUCED OR COPIED IN ANY MANNER WITHOUT THE WRITTEN PERMISSION OF THE ARCHITECT.	FILE: 010821 1 STORY		

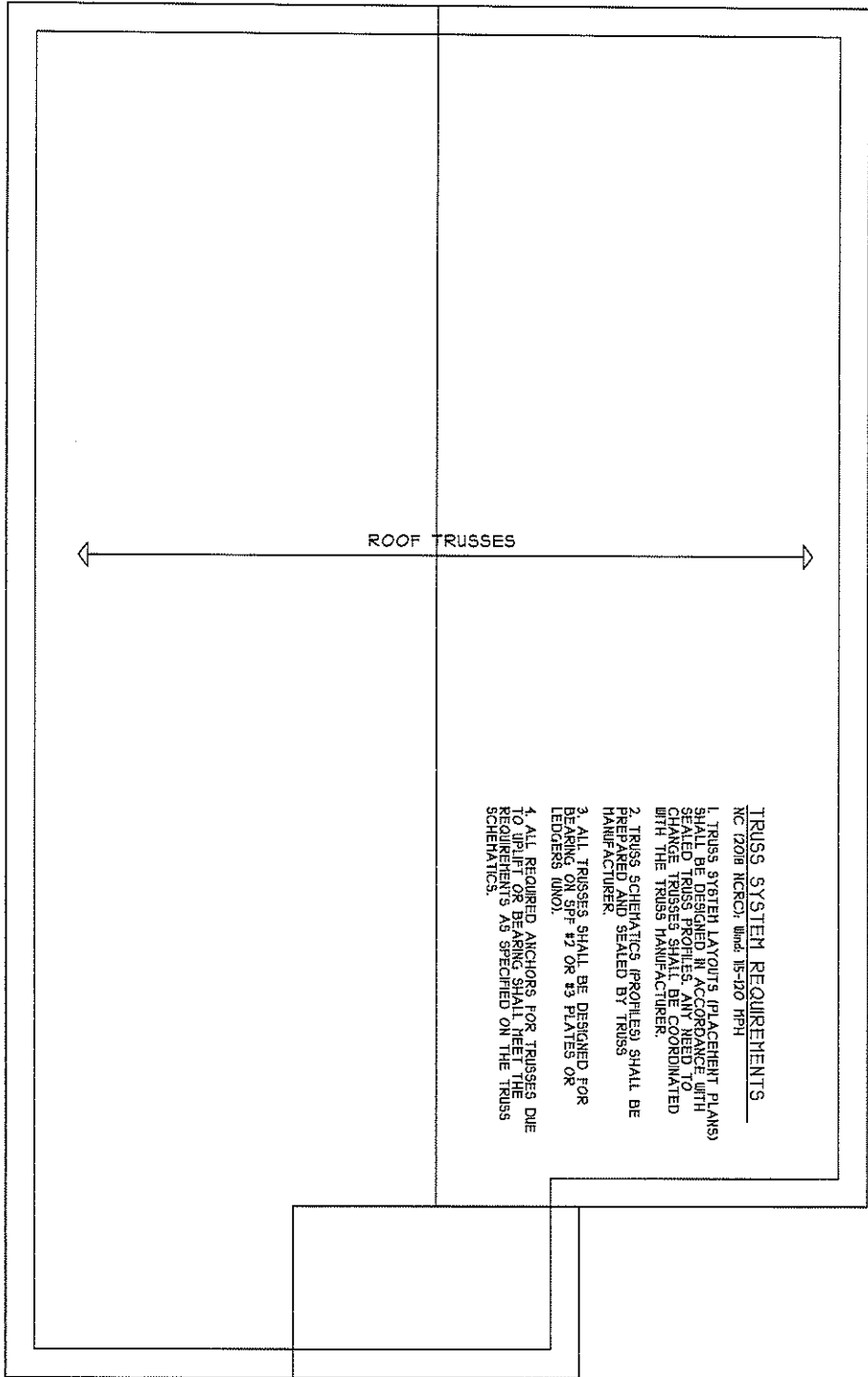

- TRUSS SYSTEM REQUIREMENTS**
 NC 2018 NCCRC, Amend. 15-120, 115H
1. TRUSS SYSTEM LAYOUTS (PLACEMENT PLANS) SHALL BE DESIGNED IN ACCORDANCE WITH SEALED TRUSS PROFILES. ANY NEED TO CHANGE TRUSSES SHALL BE COORDINATED WITH THE TRUSS MANUFACTURER.
 2. TRUSS SCHEMATICS (PROFILES) SHALL BE PREPARED AND SEALED BY TRUSS MANUFACTURER.
 3. ALL TRUSSES SHALL BE DESIGNED FOR BEARING LOADS OF #2 OR #3 PLATES OR LEADERS (MIN).
 4. ALL REQUIRED ANCHORS FOR TRUSSES DUE TO UPLIFT OR BEARING SHALL MEET THE REQUIREMENTS AS SPECIFIED ON THE TRUSS SCHEMATICS.

REFER TO BASIC DETAIL SHEETS FOR WINDOW AND STRUCTURAL NOTES

ROOF PLAN
 SCALE 1/4" = 1'-0"

SHEET NO. 010821	DATE 12/01/2011	ANY DEVIATION OF THE DESIGN OR CONSTRUCTION FROM THE PERMITTED REQUIREMENTS SHALL BE APPROVED BY THE LOCAL BUILDING DEPARTMENT. THE PLAN HAS BEEN DRAWN IN ACCORDANCE WITH NORTH CAROLINA STATE MINIMUM BUILDING CODES FOR RESIDENTIAL.	H SQUARED HOME DESIGN, INC.	HEATHER HALL 185 HEATHERSTONE CT BENSON NC 27504 (919) 207-1403	SQUARE FOOTAGE: FIRST FLOOR = 120 FRONT PORCH = 108	HEATED FOOTAGE: #1120	THE BENTLEY LEFT HAND JRT MANG. PROP.



Trenco
818 Soundside Rd
Edenton, NC 27932

Re: 28292-28292A
BENTLEY PLAN - JRT

The truss drawing(s) referenced below have been prepared by Truss Engineering Co. under my direct supervision based on the parameters provided by 84 Components - #2383.

Pages or sheets covered by this seal: 147750752 thru 147750756

My license renewal date for the state of North Carolina is December 31, 2021.

North Carolina COA: C-0844



September 3, 2021

IMPORTANT NOTE: The seal on these truss component designs is a certification that the engineer named is licensed in the jurisdiction(s) identified and that the designs comply with ANSIT/TP 1. These designs are based upon parameters shown (e.g., loads, supports, dimensions, shapes and design codes), which were given to Mittek or TRENCO. Any project specific information included is for Mittek's or TRENCO's customers the reference purpose only, and was not taken into account in the preparation of these designs. Mittek or TRENCO has not independently verified the applicability of the design parameters or the designs for any particular building. Before use, the building designer should verify applicability of design parameters and properly incorporate these designs into the overall building design per ANSIT/TP 1, Chapter 2.

Job	Truss	Truss Type	Qty	Material	Job Reference (optional)
28292-28292A	A	Common	13	Ply	BENTLEY PLAN - JRT
84 Components (Dunn), Dunn, NC - 28334, ID: 19gFtrslmsmRozD1QEH4syE227-Cg5fmGD1Y?wNmuzb_Uqm8IDICbA_Rsnz8kXyhb0 28-10-8 0-10-8					
8,520 s Aug 27 2021 MITtek Industries, Inc. Thu Sep 2 13:15:25 2021 Page 1 28-10-8 0-10-8					

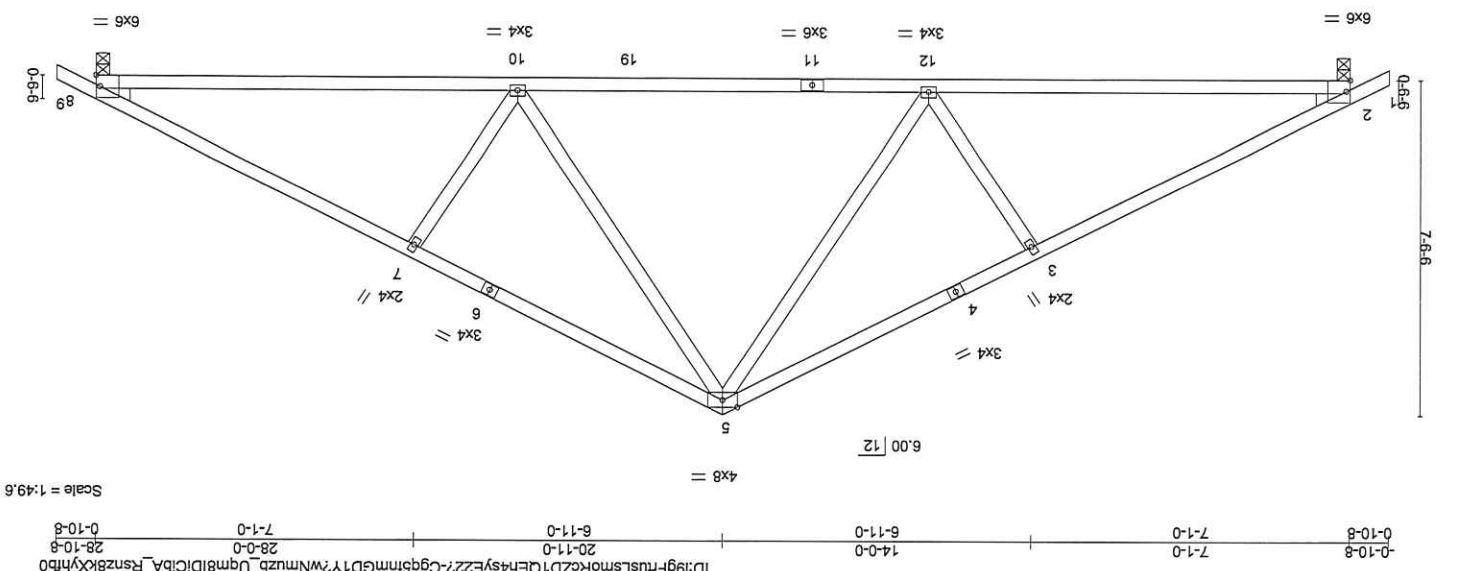

LOADING (psf)	SPACING-	CSL	DEFL.	in (loc)	I/defl	L/D
20.0	Plate Gnp DOL	TC	0.65	0.33	10-12	240
10.0	Lumber DOL	BC	0.88	-0.49	10-12	180
0.0 *	Rep Stress Incr	WB	0.27	0.06	8	n/a
10.0	Code IRC2015/TP12014	Matrx-MS				n/a

LUMBER-	BRACING-
TOP CHORD 2x4 SP No.2 or 2x4 SPF No.2	TOP CHORD Structural wood sheathing directly applied or 3-4-9 oc purlins.
BOT CHORD 2x4 SP No.2 or 2x4 SPF No.2	Rigid ceiling directly applied or 10-0-0 oc bracing.
WEBS 2x4 SP No.3	
WEDGE 2x4 SP No.3	

REACTIONS. (size) 2=0-3-8, 8=0-3-8
 Max Horiz 2=124(LC 10)
 Max Uplift 2=150(LC 10), 8=150(LC 11)
 Max Grav 2=1173(LC 1), 8=1173(LC 1)
FORCES. (lb) - Max. Comp./Max. Ten. - All forces 250 (lb) or less except when shown.
 TOP CHORD 2-3=-1915/487, 3-5=-1690/496, 5-7=-1690/496, 7-8=-1915/487
 BOT CHORD 2-12=-314/1633, 10-12=-94/1090, 8-10=-314/1633
 WEBS 5-10=-138/642, 7-10=-412/271, 5-12=-138/640, 3-12=-412/271

NOTES-
 (1) Unbalanced roof live loads have been considered for this design.
 (2) Wind: ASCE 7-10; Vult=130mph Vasd=103mph; TC DL=6.0psf; BC DL=6.0psf; h=30ft; Cat. II; Exp. B; Enclosed; MWFRS (envelope) gable end zone and C-C Exterior(2) zone; C-C for members and forces & MWFRS for reactions shown; Lumber DOL=1.60 plate gnp DOL=1.60
 (3) This truss has been designed for a 1'0" pft bottom chord live load nonconcurrent with any other live loads.
 (4) * This truss has been designed for a live load of 20'0psf on the bottom chord in all areas where a rectangle 3-6-0 tall by 2-0-0 wide will fit between the bottom chord and any other members, with BC DL = 10'0psf.
 (5) Provide mechanical connection (by others) of truss to bearing plate capable of withstanding 150 lb uplift at joint 2 and 150 lb uplift at joint 8.

September 3, 2021

818 Soundside Road
Edenton, NC 27932

WARNING - Verify design parameters and READ NOTES ON THIS AND INCLUDED MITtek REFERENCE PAGE MIH-473 REV. 5/19/2020 BEFORE USE.

Design valid for use only with MITtek connectors. This design is based only upon parameters shown, and is for an individual building component, not a truss system. Before use, the building designer must verify the applicability of design parameters and properly incorporate this design into the overall building design. Bracing indicated is to prevent buckling of individual truss web and/or chord members only. Additional temporary and permanent bracing is always required for stability and to prevent collapse with possible personal injury and property damage. For general guidance regarding the fabrication, storage, delivery, erection and bracing of trusses and truss systems, see ANSLTP14 Quality Criteria, DSB-89 and BCSI Building Component Safety Information available from Truss Plate Institute, 2670 Crain Highway, Suite 203 Waldorf, MD 20601

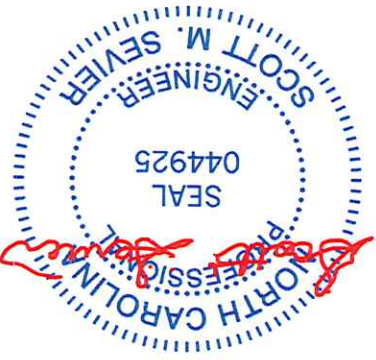

Job	Truss	Truss Type	Qty	Ply	Job Reference (optional)
28292-28292A	A1	ROOF TRUSSES	6	Ply	BENTLEY PLAN - JRT
84 Components (Dunn), Dunn, NC - 28334, ID: 19gFtHuslmsRcZD1QEH4syE227-gsOT17nuLgsvWL4XJVjNzhUx6Z0kaIasRjhzhb? 8:52 s Aug 27 2021 MITtek Industries, Inc. Thu Sep 2 13:15:26 2021 Page 1					
0-10-8 7-1-0 12-0-0 4-11-0 14-0-0 2-0-0 16-0-0 20-11-0 20-11-0 28-0-0 28-10-8 0-10-8					

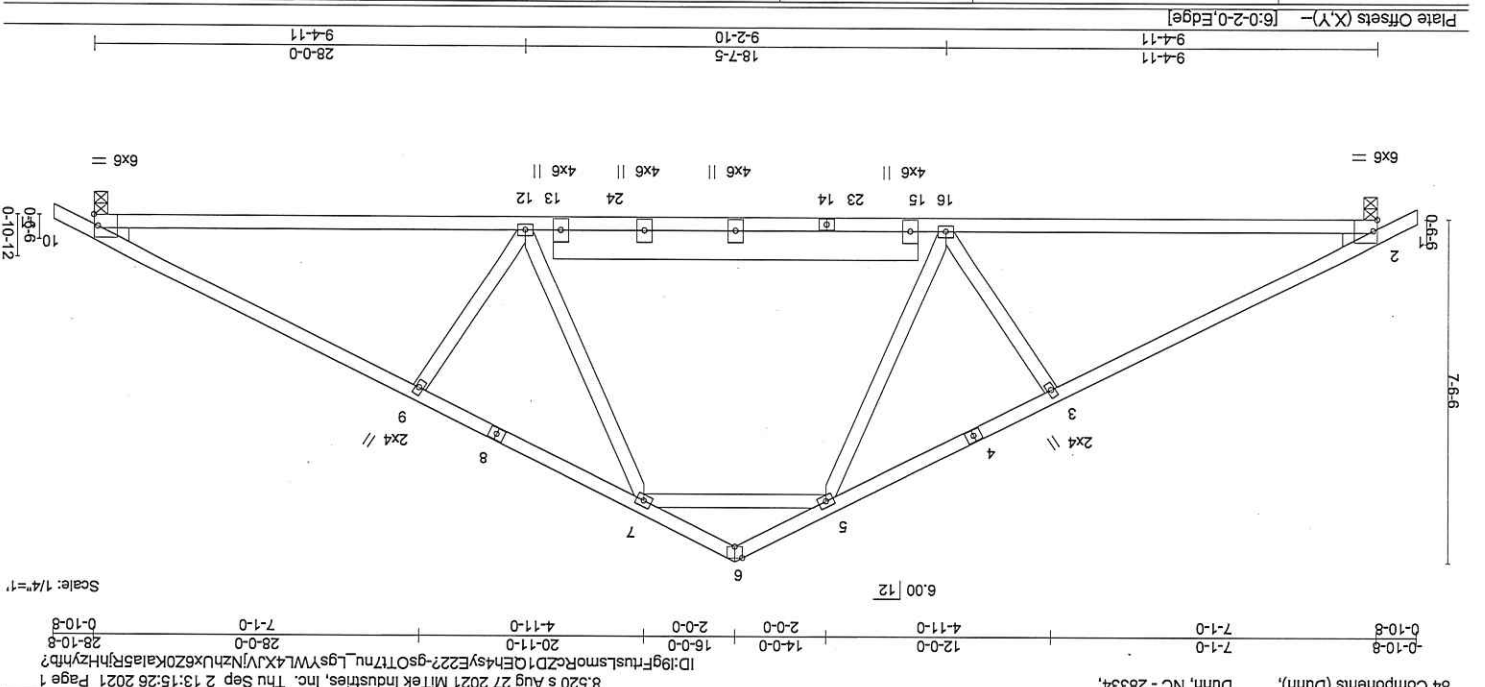

LOADING (psf)	SPACING-	CSL	DEFL.	in (loc)	l/def	L/d	PLATES	Weight: 155 lb	FT = 20%
20.0	2-0-0	0.59	-0.23	16-19	>99	240	MT20		
10.0	Lumber DOL	0.81	-0.38	16-19	>896	180	GRIP	197/144	
0.0 *	Rep Stress Incr	0.45	0.05	10	n/a	n/a			
10.0	Code IRC2015/TP2014	Mathx-MS	Horz(CT)						

LUMBER-	BRACING-
TOP CHORD	TOP CHORD
2x4 SP No.2 or 2x4 SPF No.2	Structural wood sheathing directly applied or 3-6-15 oc purlins.
13-15: 2x8 SP No.2	
WEBS	
2x4 SP No.3	
WEDGE	
Left: 2x4 SP No.3, Right: 2x4 SP No.3	

REACTIONS
(size) 2=0-3-8, 10=0-3-8
Max Horiz 2=124(LC 10), 10=150(LC 11)
Max Uplift 2=150(LC 10), 10=150(LC 11)
Max Grav 2=1173(LC 1), 10=1173(LC 1)
FORCES. (lb) - Max. Comp/Max. Ten. - All forces 250 (lb) or less except when shown.
TOP CHORD 2-3=-1895/478, 3-5=-1676/480, 7-9=-1676/480, 9-10=-1895/478
BOT CHORD 2-16=-302/1612, 12-16=-144/1232, 10-12=-302/1612
WEBS 7-12=-91/570, 9-12=-41/241, 5-16=-91/570, 3-16=-41/240, 5-7=-1168/436

NOTES:

- Unbalanced roof live loads have been considered for this design.
- Wind: ASCE 7-10; Vult=130mph Vasd=103mph; TC DL=6.0psf; BCDL=6.0psf; h=30ft; Cat. II; Exp B; Enclosed; MWFRS (envelope) gable end zone and C-C Exterior(2) zone; C-C for members and forces & MWFRS for reactions shown; Lumber DOL=1.60 plate grip DOL=1.60
- All plates are 3x4 MT20 unless otherwise indicated.
- This truss has been designed for a 10.0 psf bottom chord live load nonconcurrent with any other live loads.
- * This truss has been designed for a live load of 20.0psf on the bottom chord in all areas where a rectangle 3-6-0 tall by 2-0-0 wide will fit between the bottom chord and any other members, with BCDL = 10.0psf.
- Provide mechanical connection (by others) of truss to bearing plate capable of withstanding 150 lb uplift at joint 2 and 150 lb uplift at joint 10.
- ATTIC SPACE SHOWN IS DESIGNED AS UNINHABITABLE.

September 3, 2021

TRINCO
ENGINEERING BY
A MITtek Affiliate

818 Soundside Road
Edenton, NC 27932

WARNING - Verify design parameters and READ NOTES ON THIS AND INCLUDED MITtek REFERENCE PAGE MII-7473 rev. 5/19/2020 BEFORE USE.

Design valid for use only with MITtek connectors. This design is based only upon parameters shown, and is for an individual building component, not a truss system. Before use, the building designer must verify the applicability of design parameters and properly incorporate this design into the overall building design. Bracing indicated is to prevent buckling of individual truss web and/or chord members only. Additional temporary and permanent bracing is always required for stability and to prevent collapse with possible personal injury and property damage. For general guidance regarding the fabrication, storage, delivery, erection and bracing of trusses and truss systems, see ANSITPP Quality Criteria, DSB-63 and BCSI Building Component Safety Information available from Truss Plate Institute, 2670 Crain Highway, Suite 203 Waldorf, MD 20601

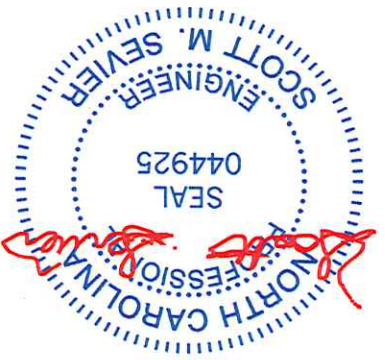

Job	28292-28292A	AE	GABLE	Qty	2	Job Reference (optional)	1
Truss				Ply		BENTLEY PLAN - JRT	
Truss Type							

84 Components (Dunn), Dunn, NC - 28334, ID:19gfrtustsmoRcZD1GEnH4syE22?-dFWEl0o8WyznqVTFtXBSOmx1wPHozqYICokryhaz 28-10-8 14-0-0 14-0-0 28-0-0 14-0-0 0-10-8 0-10-8 Scale = 1:49.7

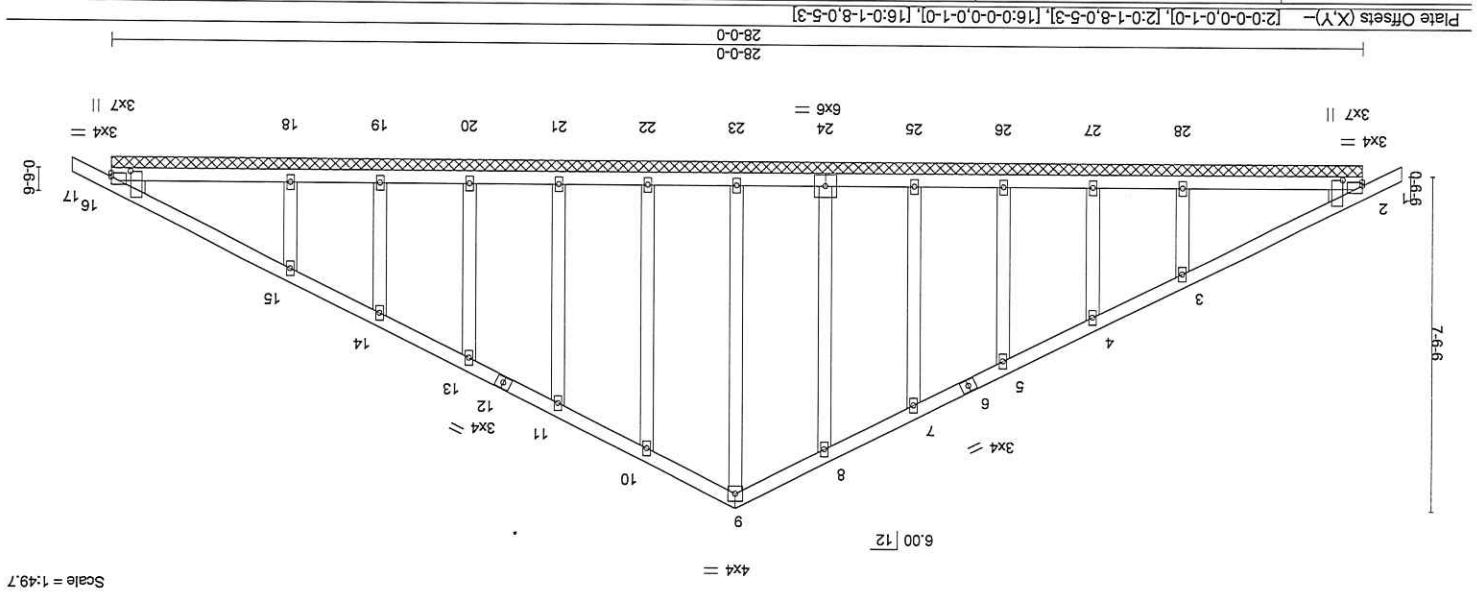

LOADING (psf)	SPACING-	CSL	DEFL	VERT (LL)	VERT (CT)	HORZ (CT)	BRACING-	TOP CHORD	BOT CHORD
20.0	2-0-0	TC 0.17	in (loc)	0.00	0.01	0.01	Structural wood sheathing directly applied or 6-0-0 oc purlins.	2x4 SP No.2 or 2x4 SPF No.2	2x4 SP No.3
TCLL	Plate Grp DOL	0.15		n/r	n/r	n/a	Rigid ceiling directly applied or 10-0-0 oc bracing.	2x4 SP No.2 or 2x4 SPF No.2	2x4 SP No.3
TCDL	Lumber DOL	1.15		n/r	n/r	n/a		2x4 SP No.2 or 2x4 SPF No.2	2x4 SP No.3
BCLL	Rep Stress Incr	YES		n/a	n/a	n/a		2x4 SP No.3	2x4 SP No.3
BCDL	Code IRC2015/TP12014	WB 0.13		n/a	n/a	n/a		2x4 SP No.3	2x4 SP No.3

REACTIONS. All bearings 28-0-0.
 (lb) - Max Horz 2=124(LC 10)
 Max Uplift All uplift 100 lb or less at joint(s) 2, 16, 24, 25, 26, 27, 21, 20, 19 except 28=105(LC 10), 18=103(LC 11)
 Max Grav All reactions 250 lb or less at joint(s) 2, 16, 23, 24, 25, 26, 27, 22, 21, 20, 19 except 28=34(LC 21), 18=314(LC 22)
FORCES. (lb) - Max. Comp./Max. Ten. - All forces 250 (lb) or less except when shown.

NOTES-
 (1) Unbalanced roof live loads have been considered for this design.
 (2) Wind: ASCE 7-10; Vult=130mph Vasd=103mph; TC DL=6.0psf; BCDL=6.0psf; h=30ft; Cat. II; Exp B; Enclosed; MWFRS (envelope)
 gable end zone and C-C Exterior(2) zone; C-C for members and forces & MWFRS for reactions shown; Lumber DOL=1.60 plate grp
 DOL=1.60
 (3) Truss designed for wind loads in the plane of the truss only. For studs exposed to wind (normal to the face), see Standard Industry Gable End Details as applicable, or consult qualified building designer as per ANSIT/P1.
 (4) All plates are 2x4 MT20 unless otherwise indicated.
 (5) Gable requires continuous bottom chord bearing.
 (6) Gable studs spaced at 2-0-0 oc.
 (7) This truss has been designed for a 10.0 psf bottom chord live load nonconcurrent with any other live loads.
 (8) * This truss has been designed for a live load of 20.0psf on the bottom chord in all areas where a rectangle 3-6-0 tall by 2-0-0 wide will fit between the bottom chord and any other members.
 (9) Provide mechanical connection (by others) of truss to bearing plate capable of withstanding 100 lb uplift at joint(s) 2, 16, 24, 25, 26, 27, 22, 21, 20, 19 except (1=lb) 28=105, 18=103.

WARNING - Verify design parameters and READ NOTES ON THIS AND INCLUDED MTEK REFERENCE PAGE MII-7473 REV. 5/19/2020 BEFORE USE.
 Design valid for use only with MITek connectors. This design is based only upon parameters shown, and is for an individual building component, not a truss system. Before use, the building designer must verify the applicability of individual truss web and/or chord members and properly incorporate this design into the overall building design. Bracing indicated is to prevent buckling of individual truss web and/or chord members only. Additional temporary and permanent bracing is always required for stability and to prevent collapse with possible personal injury and property damage. For general guidance regarding the fabrication, storage, delivery, erection and bracing of trusses and truss systems, see ANSIT/P1 Quality Criteria, DSB-69 and BCSI Building Component Safety Information available from Truss Plate Institute, 2670 Crain Highway, Suite 203 Waldorf, MD 20601



September 3, 2021
TRENCO
 ENGINEERING BY
 A MITEK Affiliate
 818 Soundside Road
 Edenton, NC 27932

Job	Truss Type	Qty	Ply	Job Reference (optional)
28292-28292A	B	Common	1	BENTLEY PLAN - JRT

84 Components (Dunn), Dunn, NC - 28334, ID:19gFtrussmorcZD1QEH4syE22-5R4cV8pmHG2QP_4fCR2Q?c44ebzbzX081nPxLlthfay 8.520 s Aug 27 2021 MITTEK Industries, Inc. Thu Sep 2 13:15:29 2021 Page 1
 0-10-8 4-7-0 9-0-0 4-5-0 13-5-0 18-0-0 4-7-0 0-10-8 18-10-8 0-10-8

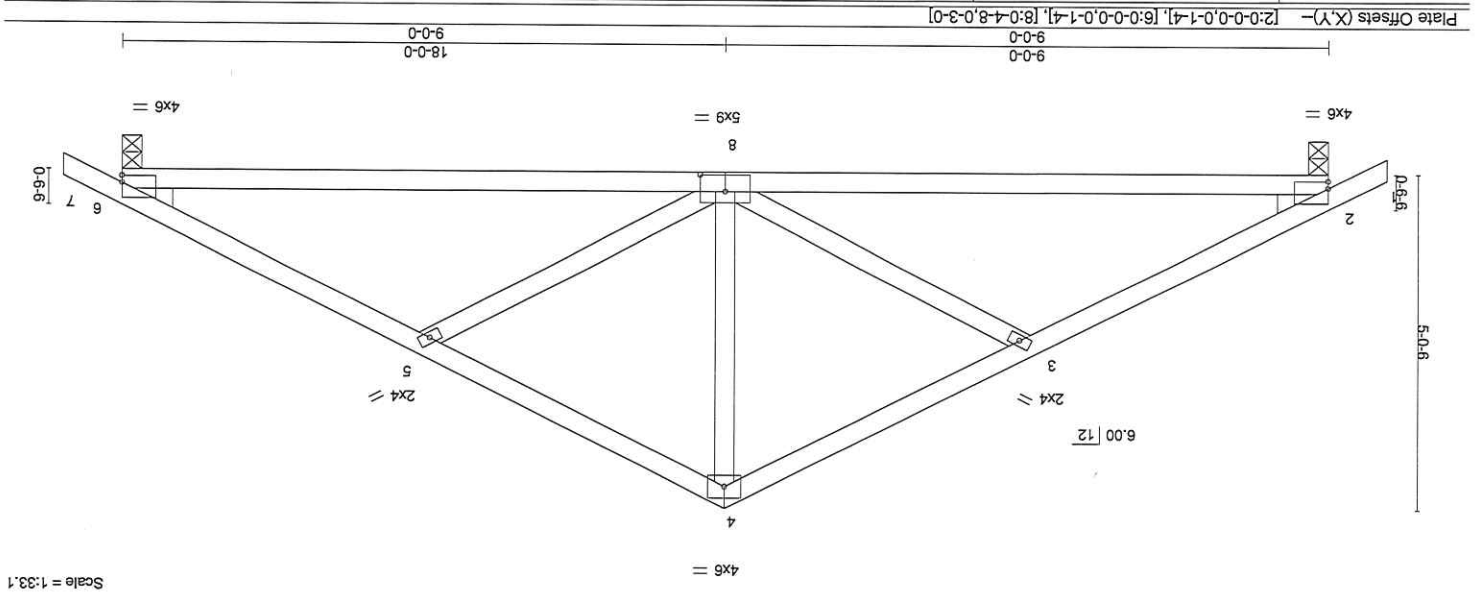

LOADING (psf)	SPACING-	CSI.	DEFL.	BRACING-
TCLL 20.0	Plate Grp DOL 1.15	TC 0.24	Vert(LL) -0.10	TOP CHORD
TCDL 10.0	Lumber DOL 1.15	BC 0.73	Vert(CT) -0.21	BOT CHORD
BCLL 0.0 *	Rep Stress Incr YES	WB 0.19	Horz(CT) 0.03	
BCDL 10.0	Code IRC2015/TP2014	Matrx-MS		

LUMBER- TOP CHORD 2x4 SP No.2 or 2x4 SPF No.2
 BOT CHORD 2x4 SP No.2 or 2x4 SPF No.2
 WEBS 2x4 SP No.3
 WEDGE Left: 2x4 SP No.3, Right: 2x4 SP No.3

REACTIONS, (size) 2=0-3-8, 6=0-3-8
 Max Horz 2=-82(LC 11)
 Max Uplift 2=-103(LC 10), 6=-103(LC 11)
 Max Grav 2=773(LC 1), 6=773(LC 1)

FORCES, (lb) - Max. Comp./Max. Ten. - All forces 250 (lb) or less except when shown.
 TOP CHORD 2-3=-1159/318, 3-4=-870/233, 4-5=-870/233, 5-6=-1159/318
 BOT CHORD 2-8=-191/986, 6-8=-191/986
 WEBS 4-8=-61/503, 5-8=-319/189, 3-8=-319/189

NOTES-
 (1) Unbalanced roof live loads have been considered for this design.
 (2) Wind: ASCE 7-10; Vuil=130mph Vasd=103mph; TCDL=6.0psf; BCDL=6.0psf; h=30ft; Cat. II; Exp B; Enclosed; MWFRS (envelope) gable end zone and C-C Exterior(2) zone; C-C for members and forces & MWFRS for reactions shown; Lumber DOL=1.60 plate grp DOL=1.60
 (3) This truss has been designed for a 10.0 psf bottom chord live load nonconcurrent with any other live loads.
 (4) * This truss has been designed for a live load of 20.0psf on the bottom chord in all areas where a rectangle 3-6-0 tall by 2-0-0 wide will fit between the bottom chord and any other members.
 (5) Provide mechanical connection (by others) of truss to bearing plate capable of withstanding 100 lb uplift at joint(s) except (t=lb) 2=103, 6=103.

TRANGO ENGINEERING BY
 A MITTEK AFFILIATE
 818 Soundside Road
 Edenonton, NC 27932

WARNING - Verify design parameters and READ NOTES ON THIS AND INCLUDED MITTEK REFERENCE PAGE MII-7473 rev. 5/19/2020 BEFORE USE.
 Design valid for use only with MITTEK connectors. This design is based upon parameters shown, and is for an individual building component, not a truss system. Before use, the building designer must verify the applicability of design parameters and properly incorporate this design into the overall building design. Bracing indicated is to prevent buckling of individual truss web and chord members only. Additional temporary and permanent bracing is always required for stability and to prevent collapse with possible personal injury and property damage. For general guidance regarding the fabrication, storage, delivery, erection and bracing of trusses and truss systems, see ANSLI/TPI Quality Criteria, DSB-89 and BCSI Building Component Safety Information available from Truss Plate Institute, 2670 Crain Highway, Suite 203 Waldorf, MD 20601

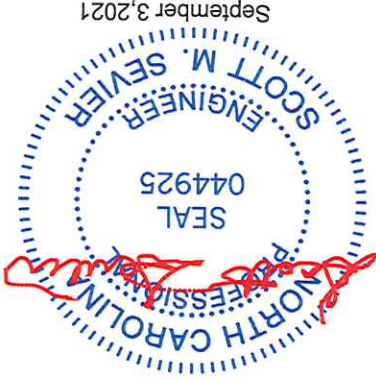

September 3, 2021

Symbols

PLATE LOCATION AND ORIENTATION

Center plate on joint unless x, y offsets are indicated. Dimensions are in ft-in-sixteenths. Apply plates to both sides of truss and fully embed teeth.

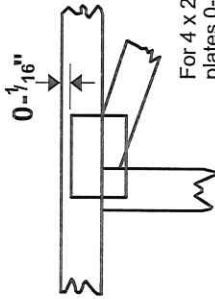

For 4 x 2 orientation, locate plates 0- 1/16" from outside edge of truss.

This symbol indicates the required direction of slots in connector plates.



* Plate location details available in MiTek 20/20 software or upon request.

PLATE SIZE

4 X 4

The first dimension is the plate width measured perpendicular to slots. Second dimension is the length parallel to slots.

LATERAL BRACING LOCATION



Indicated by symbol shown and/or by text in the bracing section of the output. Use T or I bracing if indicated.

BEARING

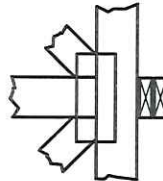

Indicates location where bearings (supports) occur. Icons vary but reaction section indicates joint number where bearings occur. Min size shown is for crushing only.

Industry Standards:

ANSI/TPI1: National Design Specification for Metal Plate Connected Wood Truss Construction.
DSB-89: Design Standard for Bracing.
BCSI: Building Component Safety Information, Guide to Good Practice for Handling, Installing & Bracing of Metal Plate Connected Wood Trusses.

Numbering System

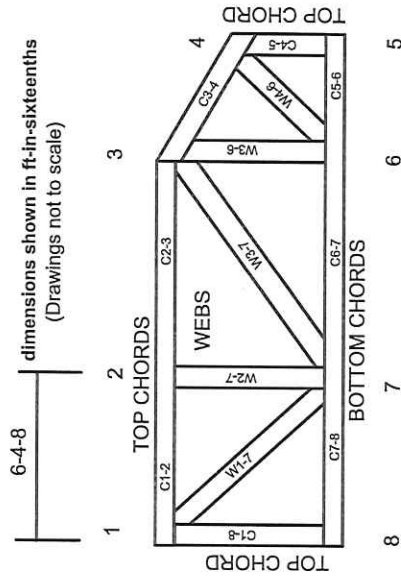

JOINTS ARE GENERALLY NUMBERED/LETTERED CLOCKWISE AROUND THE TRUSS STARTING AT THE JOINT FARTHEST TO THE LEFT.

CHORDS AND WEBS ARE IDENTIFIED BY END JOINT NUMBERS/LETTERS.

PRODUCT CODE APPROVALS

ICC-ES Reports:

ESR-1311, ESR-1352, ESR1988
ER-3907, ESR-2362, ESR-1397, ESR-3282

Trusses are designed for wind loads in the plane of the truss unless otherwise shown.

Lumber design values are in accordance with ANSI/TPI 1 section 6.3 These truss designs rely on lumber values established by others.

© 2012 MiTek® All Rights Reserved



MiTek Engineering Reference Sheet: MI-7473 rev. 5/19/2020

General Safety Notes

Failure to Follow Could Cause Property Damage or Personal Injury

- Additional stability bracing for truss system, e.g. diagonal or X-bracing, is always required. See BCSI.
- Truss bracing must be designed by an engineer. For wide truss spacing, individual lateral braces themselves may require bracing, or alternative Torl bracing should be considered.
- Never exceed the design loading shown and never stack materials on inadequately braced trusses.
- Provide copies of this truss design to the building designer, erection supervisor, property owner and all other interested parties.
- Cut members to bear tightly against each other.
- Place plates on each face of truss at each joint and embed fully. Knots and wane at joint locations are regulated by ANSI/TPI 1.
- Design assumes trusses will be suitably protected from the environment in accord with ANSI/TPI 1.
- Unless otherwise noted, moisture content of lumber shall not exceed 19% at time of fabrication.
- Unless expressly noted, this design is not applicable for use with fire retardant, preservative treated, or green lumber.
- Camber is a non-structural consideration and is the responsibility of truss fabricator. General practice is to camber for dead load deflection.
- Plate type, size, orientation and location dimensions indicated are minimum plating requirements.
- Lumber used shall be of the species and size, and in all respects, equal to or better than that specified.
- Top chords must be sheathed or purlins provided at spacing indicated on design.
- Bottom chords require lateral bracing at 10 ft. spacing, or less, if no ceiling is installed, unless otherwise noted.
- Connections not shown are the responsibility of others.
- Do not cut or alter truss member or plate without prior approval of an engineer.
- Install and load vertically unless indicated otherwise.
- Use of green or treated lumber may pose unacceptable environmental, health or performance risks. Consult with project engineer before use.
- Review all portions of this design (front, back, words and pictures) before use. Reviewing pictures alone is not sufficient.
- Design assumes manufacture in accordance with ANSI/TPI 1 Quality Criteria.
- The design does not take into account any dynamic or other loads other than those expressly stated.

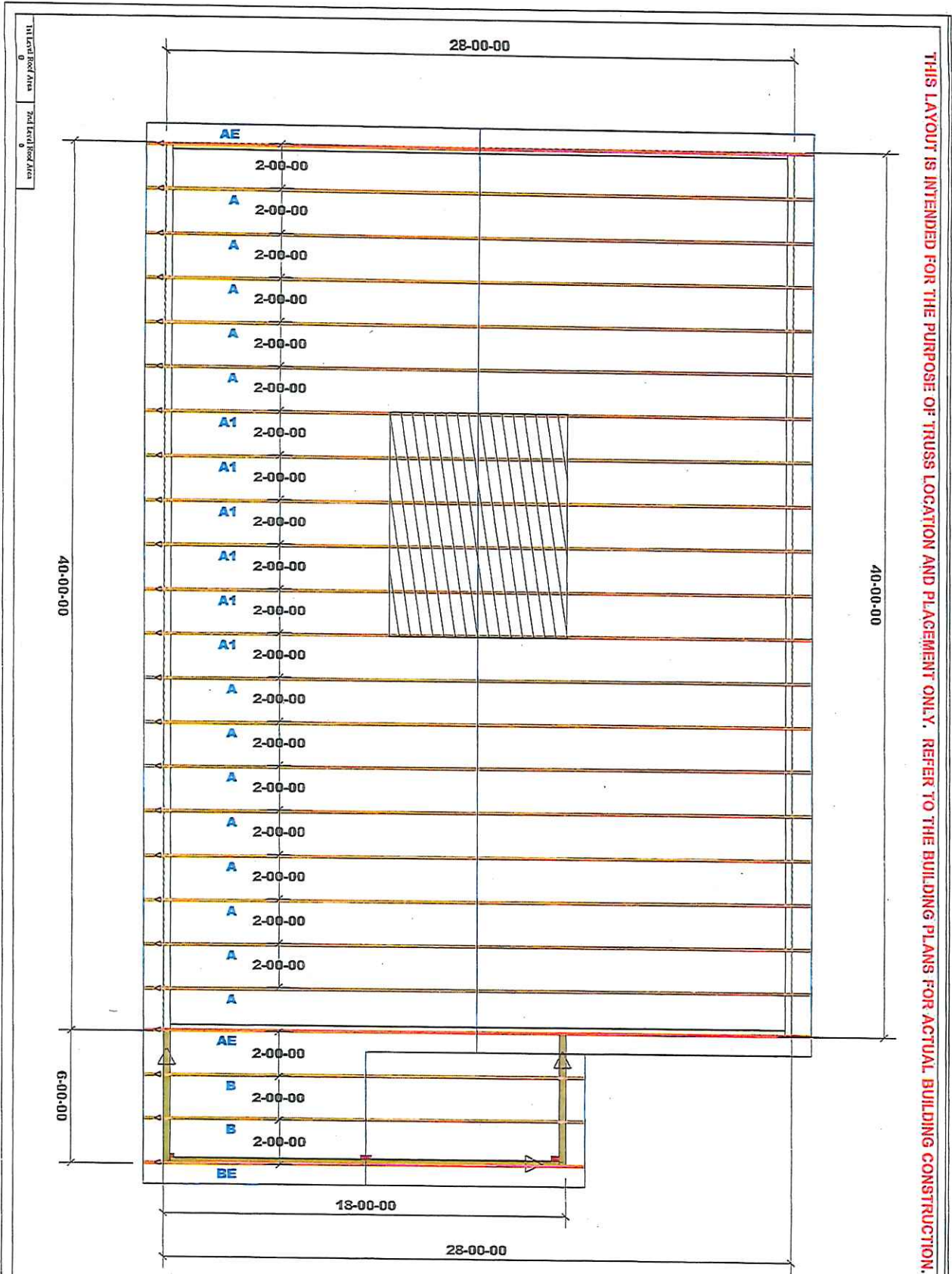

THIS LAYOUT IS INTENDED FOR THE PURPOSE OF TRUSS LOCATION AND PLACEMENT ONLY. REFER TO THE BUILDING PLANS FOR ACTUAL BUILDING CONSTRUCTION.

<p>GENERAL NOTES:</p> <ul style="list-style-type: none"> - DO NOT CUT OR MODIFY TRUSSES - TRUSSES ARE SPACED 24" ON CENTER UNLESS OTHERWISE NOTED - REFER TO THE INDIVIDUAL TRUSS DESIGN DRAWINGS FOR THE LOCATION OF LATERAL BRACING AND MULTIPLY CONNECTION REQUIREMENTS. - PER ANSI TP1-1-2002 THE TRUSS ENGINEER IS RESPONSIBLE FOR TRUSS TO TRUSS CONNECTIONS AND TRUSS PLY TO PLY CONNECTIONS. THIS TRUSS LAYOUT PLAN RECOMMENDS TRUSS TO BEARING CONNECTIONS AND TRUSS TO BEAM CONNECTIONS WHICH SHALL BE REVIEWED BY THE BUILDING DESIGNER. IT IS THE RESPONSIBILITY OF THE BUILDING DESIGNER TO RESOLVE ALL ROOF FORCES ADEQUATELY TO THE FOUNDATION. 	<p>VOID STRENGTH: 150 MPa</p> <p>DOT TO DOT LOAD: 100 kN/m²</p> <p>TOP DEAD LOAD: 100 kN/m²</p> <p>TOP LIVE LOAD: 200 kN/m²</p>	<p>PROJECT: BENTLEY PLAN - JRT</p>	<p>LOCATED TO QUALITY AND EXCELLENCE</p> <p>200 E. WYATT ROAD FAYETTEVILLE, NC 28404 PHONE: 704-392-8400</p>
		<p>CUSTOMER: 2307-84 Fayetteville</p>	
		<p>MODEL: THE BENTLEY</p>	
		<p>QUOTE #: 28292 PRINT DATE: 9/2/2021 DRAWN BY: SCALE: N.T.S</p>	

