



FRONT ELEVATION I

SCALE: 1/8" = 1'-0"



REAR ELEVATION I

SCALE: 1/8" = 1'-0"

MASTER PLAN INFORMATION	
REVISION DATE	UPDATED DATE
R3-RALE 08-23-2019	12-21-2020

DRAWN BY:	ITS
DATE:	06/07/2022
PLAN NO.	2223



HOUSE NAME:	ELMHURST
DRAWING TITLE	FRONT & REAR ELEVATIONS

SHEET No.	A.I.
-----------	------

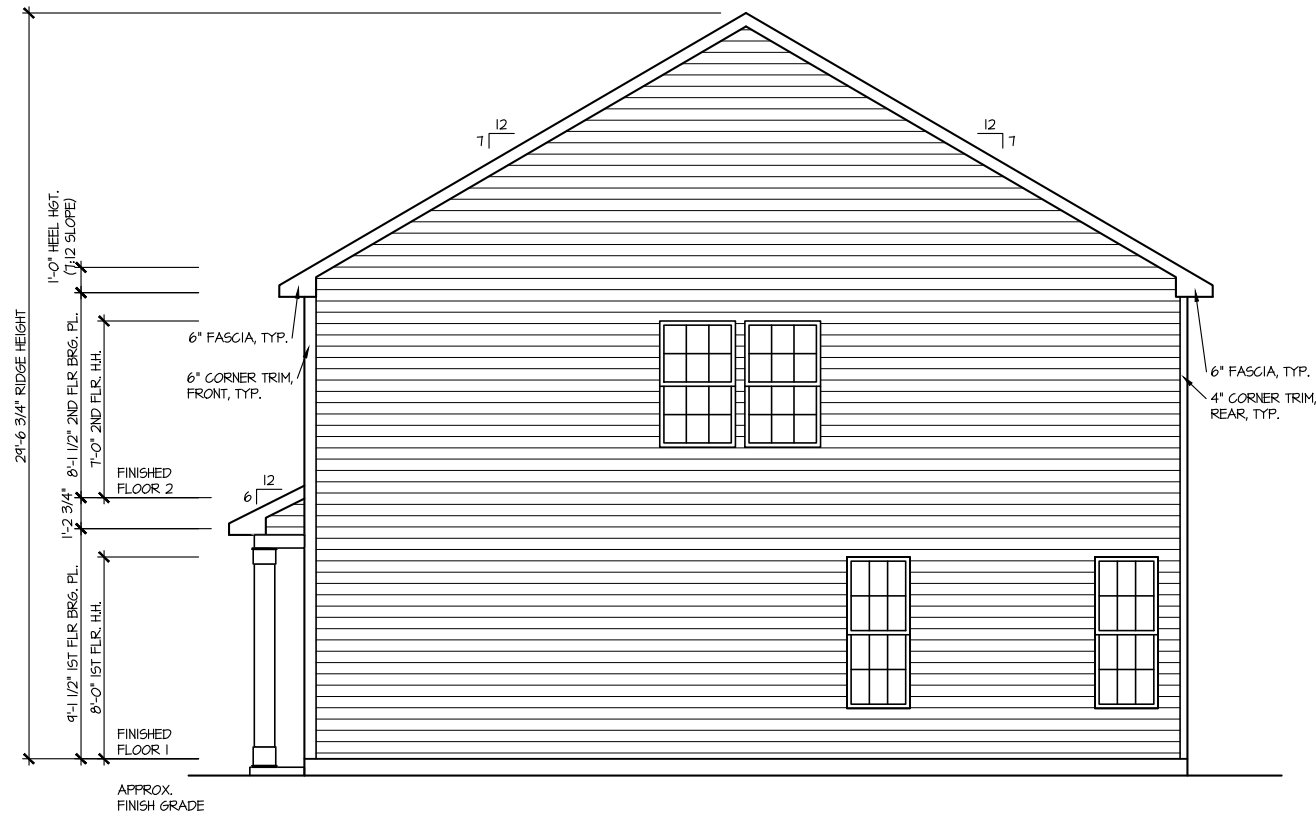

RIGHT ELEVATION I

SCALE: 1/8" = 1'-0"



LEFT ELEVATION I

SCALE: 1/8" = 1'-0"

MASTER PLAN INFORMATION		UPDATED DATE
REVISION	DATE	12-21-2020
R3-RALE	08-23-2019	

DRAWN BY:	ITS
DATE:	06/07/2022
PLAN NO.	2223



HOUSE NAME:	ELMHURST
DRAWING TITLE	RIGHT & LEFT ELEVATIONS

SHEET No.	A1.2
-----------	------

ROOF VENTILATION CALCULATIONS: OPT. THIRD FLOOR

ROOF AREA = 1344 SQ. FT.
 OVERALL REQUIRED VENTILATION:
 1 TO 150 = 8.96 SQ. FT.
 1 TO 300 = 4.48 SQ. FT.
 50-80% IN TOP THIRD = 2.24- 3.58 FT. (1 TO 300)
 NET FREE AREA OF VENTED SOFFIT = 5.1 SQ. IN / LINEAR FT.
 NET FREE AREA OF RIDGE VENT = 18 SQ. IN / LINEAR FT.
 LOWER VENTING: (BOTTOM 2/3 RDS)
 80 LINEAR FEET OF SOFFIT X 5.1 SQ. IN. = 3.16 SQ. FT.
 UPPER VENTING: (TOP 1/3 RD)
 20 LINEAR FEET OF RIDGE X 18 SQ. IN. = 2.5 SQ. FT.
 2.5 SQ. FT. BETWEEN 50% - 80%
 (1 TO 300 ALLOWED)
 TOTAL ROOF VENTILATION: 5.66 SQ. FT. > 4.48 SQ. FT. (REQ'D)

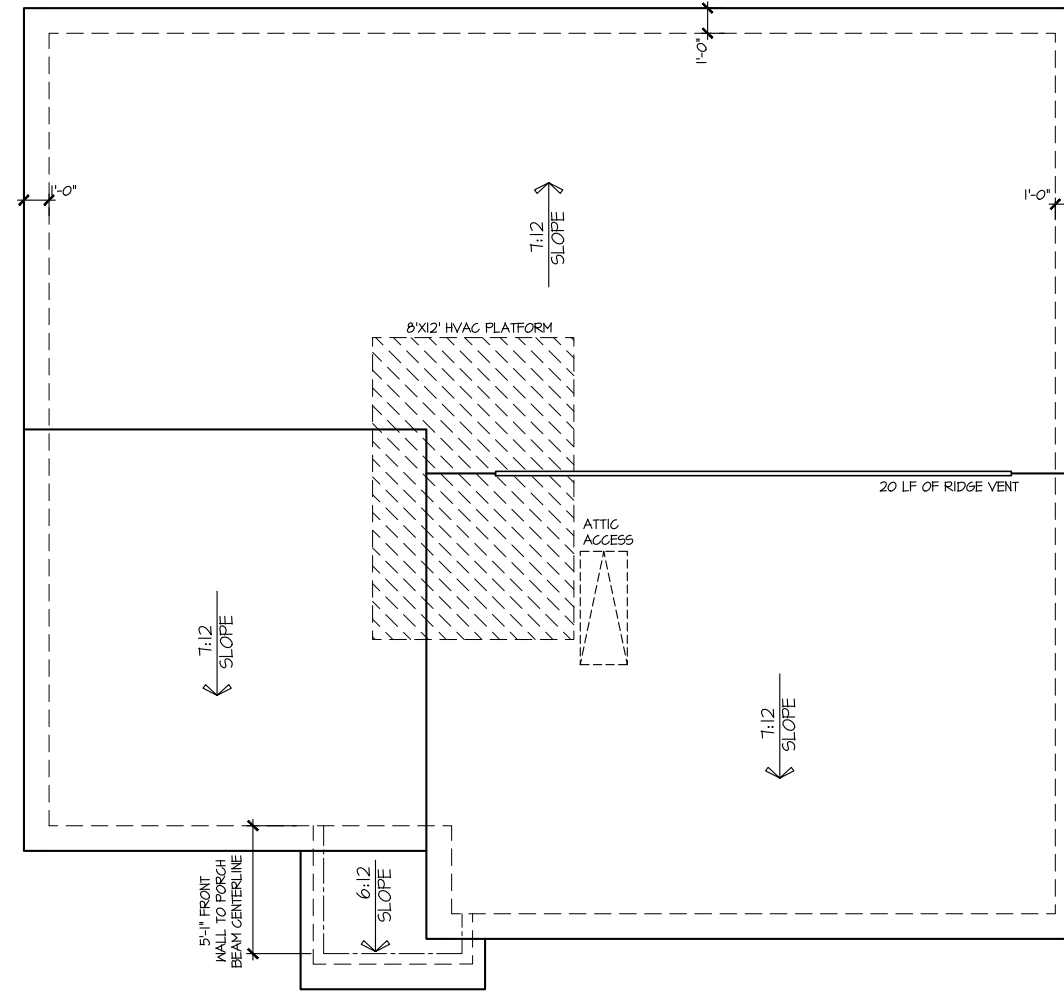

ROOF PLAN ELEV. 1

SCALE: 1/8" = 1'-0"

MASTER PLAN INFORMATION		UPDATED DATE
REVISION	DATE	
R3-RALE	08-23-2019	12-21-2020

DRAWN BY: ITS
 DATE: 06/07/2022
 PLAN NO. 2223



HOUSE NAME: ELMHURST
 DRAWING TITLE: ROOF PLAN

SHEET No. A1.3

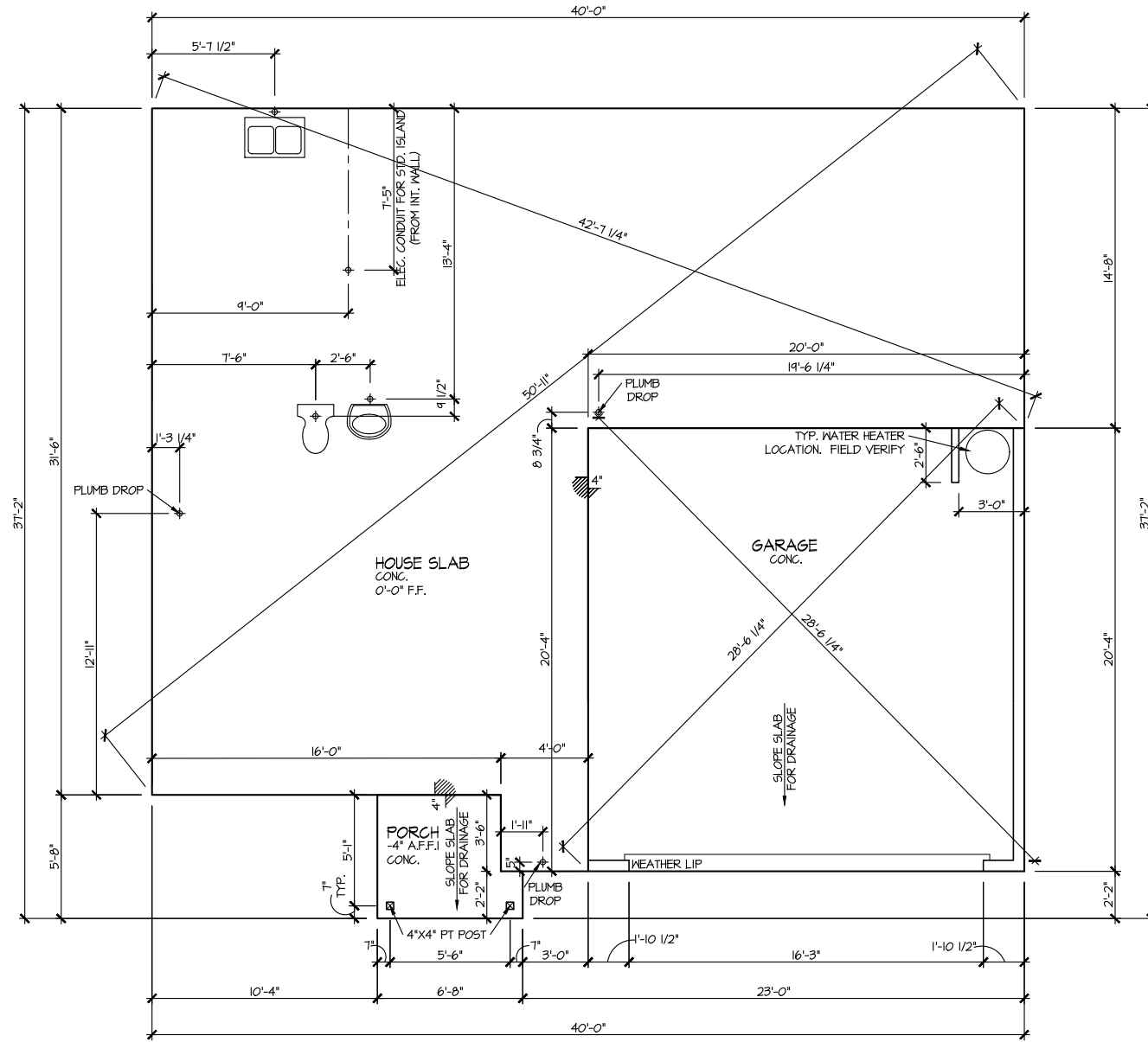

ELEVATION 1
SLAB PLAN
SCALE: 1/8" = 1'-0"

MASTER PLAN INFORMATION		UPDATED DATE
REVISION	DATE	
R3-RALE	08-23-2019	12-21-2020

DRAWN BY:	ITS
DATE:	06/07/2022
PLAN NO.	2223



HOUSE NAME:	ELMHURST
DRAWING TITLE	SLAB PLAN

SHEET No.	A2.1
-----------	------

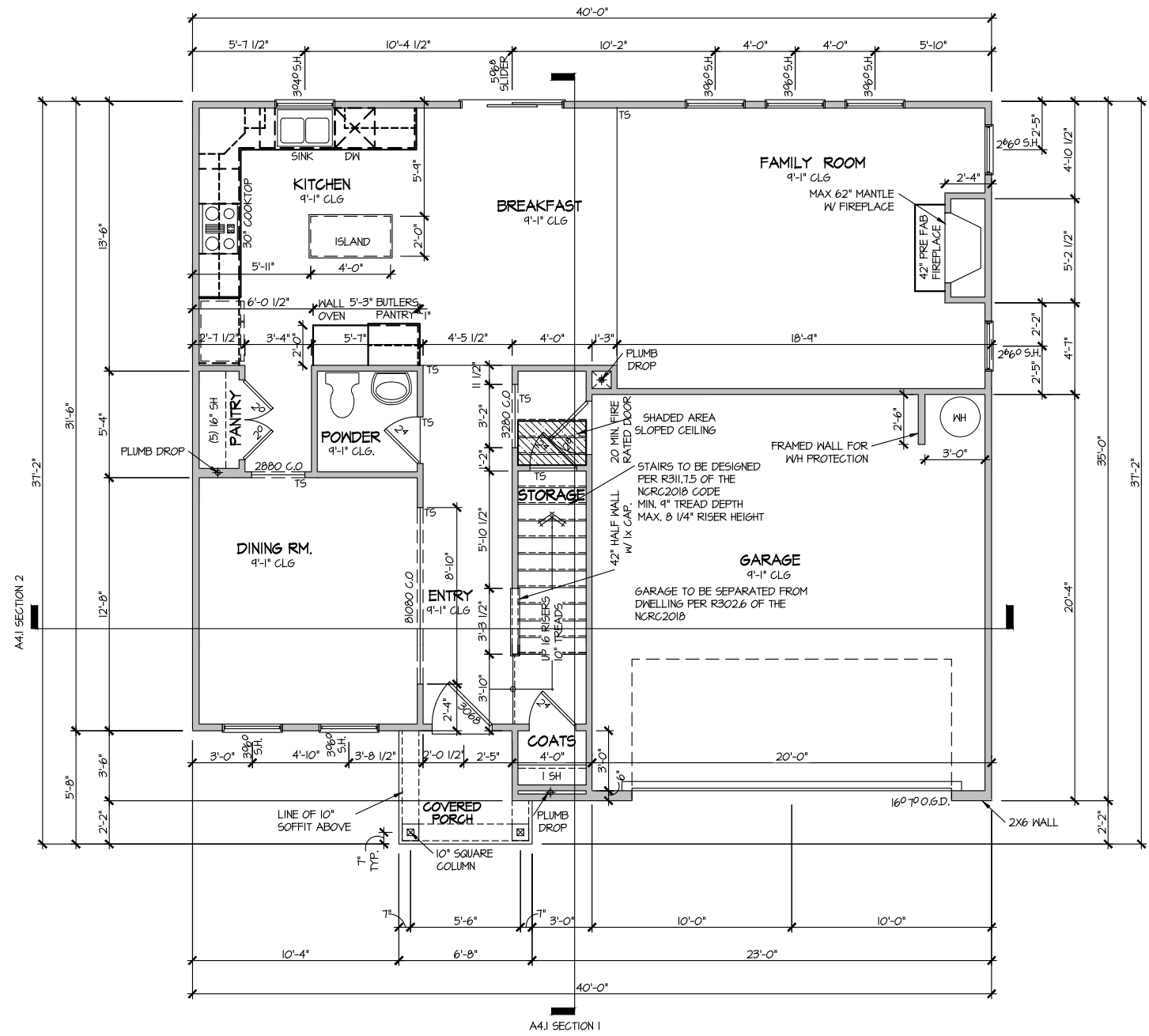

ELEVATION I
 FIRST FLOOR PLAN
 SCALE: 1/8" = 1'-0"

MASTER PLAN INFORMATION	
REVISION	DATE
R3-RALE	08-23-2019
UPDATED DATE	12-21-2020

DRAWN BY:	ITS
DATE:	06/07/2022
PLAN NO.	2223



HOUSE NAME:	ELMHURST
DRAWING TITLE	FIRST FLOOR PLAN

SHEET No.	A3.1
-----------	------

FILE: Lot 00.0123.dwg DATE: 6/7/2022

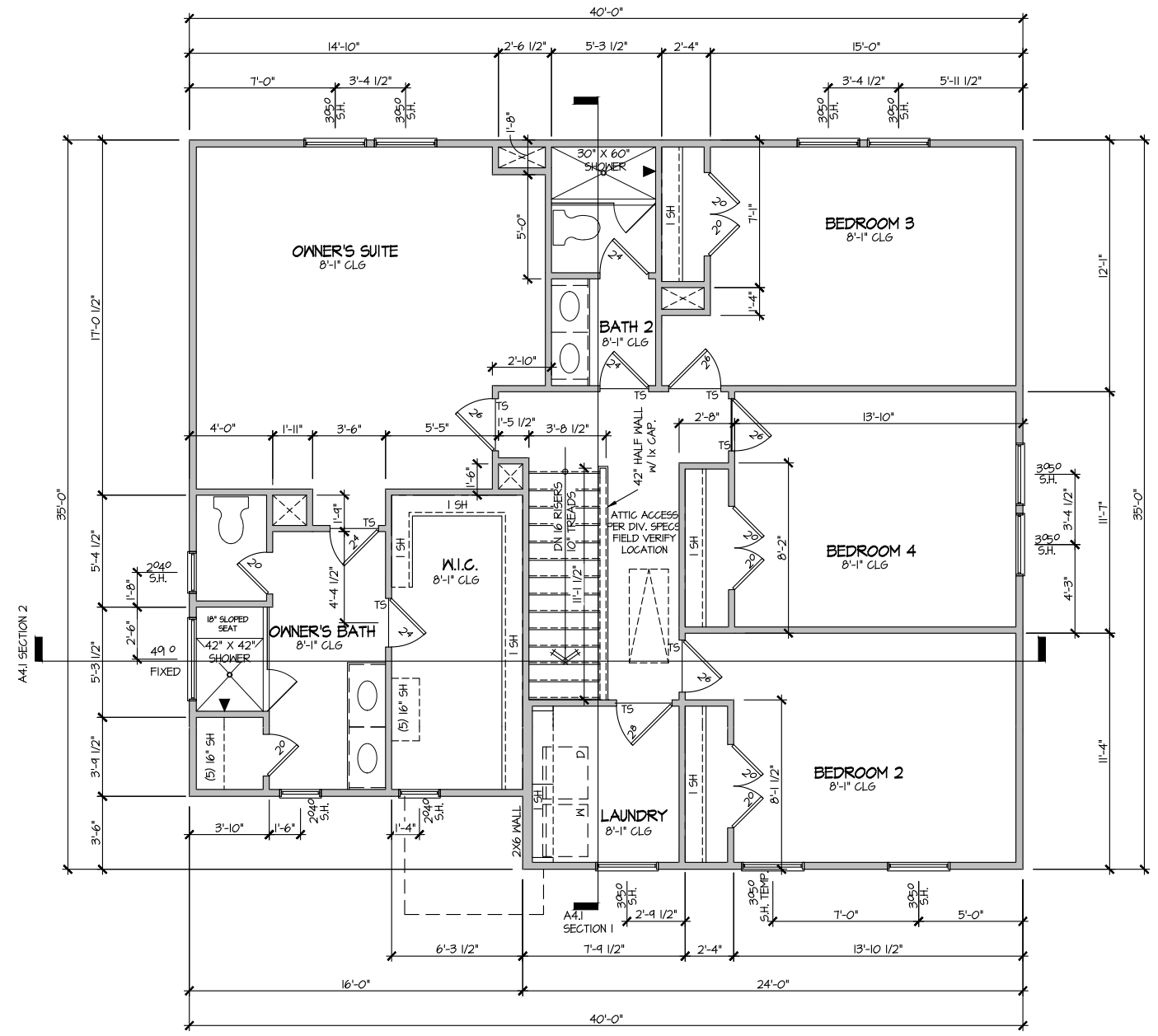

ELEVATION I
SECOND FLOOR PLAN
SCALE: 1/8" = 1'-0"

MASTER PLAN INFORMATION	
REVISION	DATE
R3-RALE	08-23-2019
UPDATED DATE	12-21-2020

DRAWN BY:	ITS
DATE:	06/07/2022
PLAN NO.	2223



HOUSE NAME:	ELMHURST
DRAWING TITLE	SECOND FLOOR PLAN

SHEET No.	A3.2
-----------	------

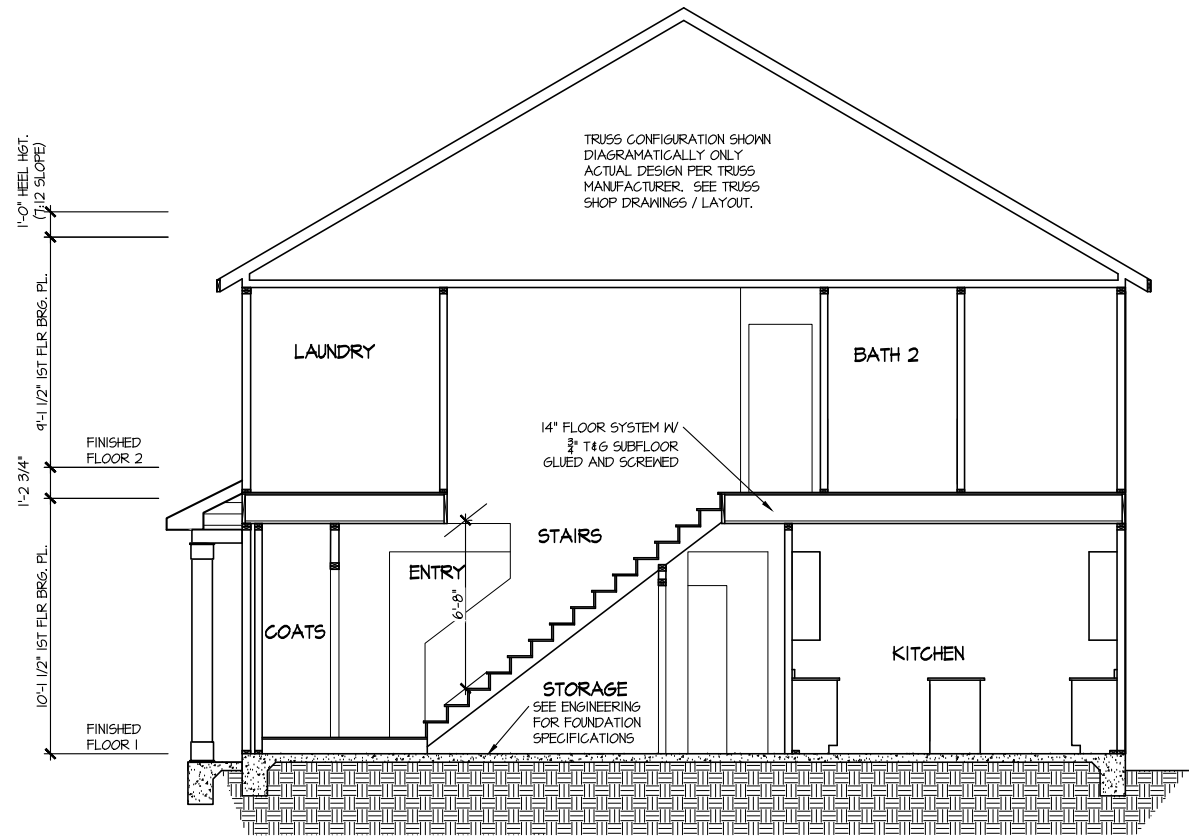

SECTION 1
SCALE: 1/8" = 1'-0"

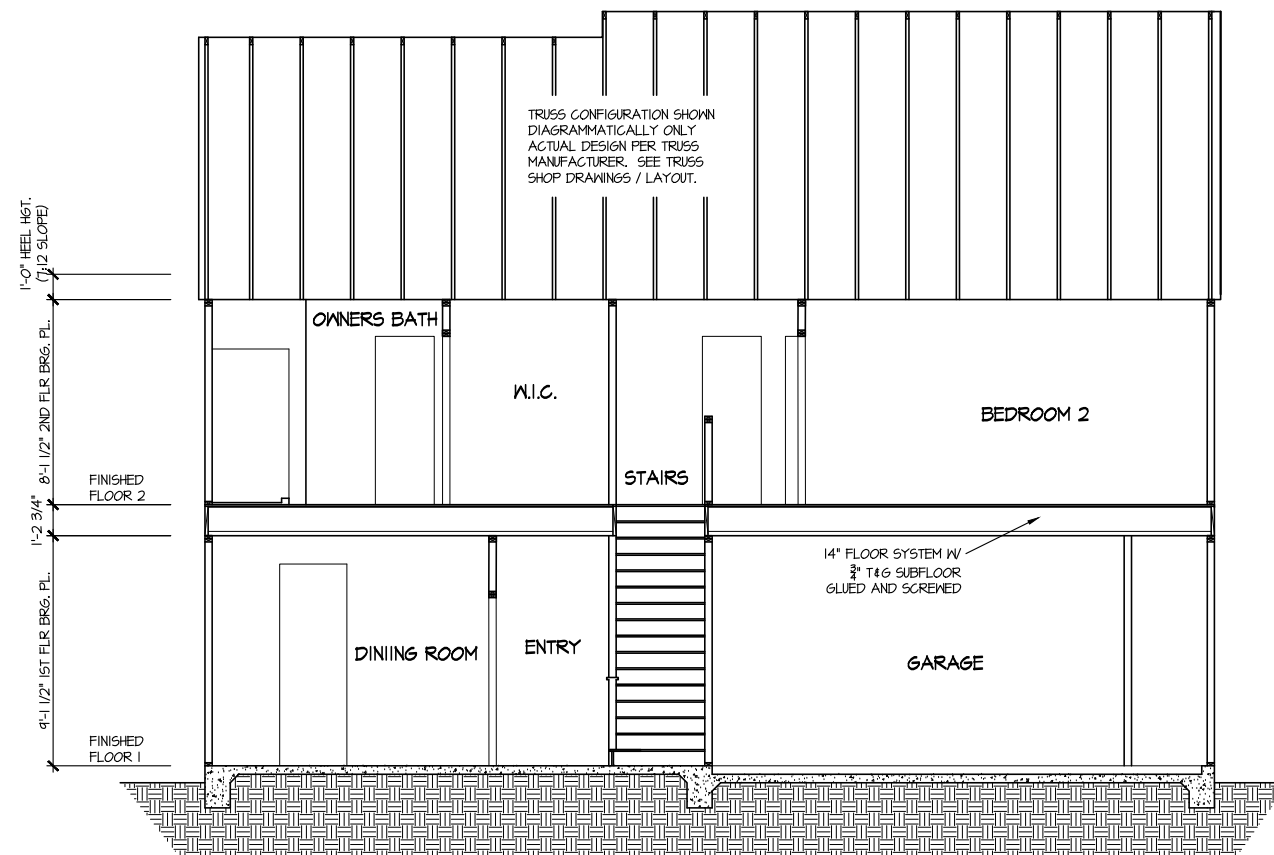

SECTION 2
SCALE: 1/8" = 1'-0"

MASTER PLAN INFORMATION		UPDATED DATE
REVISION	DATE	12-21-2020
R3-RALE	08-23-2019	

DRAWN BY:	ITS
DATE:	06/07/2022
PLAN NO.	2223



HOUSE NAME:	ELMHURST
DRAWING TITLE	BUILDING SECTION

SHEET No.	A4.1
-----------	------

ELECTRICAL LEGEND

- ⊕ SINGLE POLE SWITCH
- ⊕₃ THREE WAY SWITCH
- ⊕₄ FOUR WAY SWITCH
- ⊕-⊕ DUPLEX AFCI RECEPTACLE
- ⊕-⊕ DUPLEX AFCI RECEPTACLE - BOTTOM HALF SWITCHED
- ⊕-⊕ DUPLEX AFCI RECEPTACLE - FLOOR MOUNTED
- 220V ⊕ RECEPTACLE - 220V
- GFI ⊕ DUPLEX AFCI RECEPTACLE - GFI
- WP/GFI ⊕ DUPLEX AFCI RECEPTACLE - WATERPROOF GFI
- ⊕-⊕ SMOKE DETECTOR - WIRED IN SERIES
- ⊕ EXHAUST FAN MOTOR
- ⊕ CO DETECTOR
- ⊕ DOOR CHIME
- ⊕ LIGHT FIXTURE - WALL MOUNTED
- ⊕ LIGHT FIXTURE - CEILING MOUNTED
- ⊕ LIGHT FIXTURE - RECESSED CAN
- LED ⊕ LIGHT FIXTURE - LED SURFACE MOUNTED
- ⊕ FULLCHAIN LAMPHOLDER
- ⊕ KEYLESS LAMPHOLDER

NOTE: ALL ELECTRICAL WORK SHALL CONFORM TO THE REQUIREMENTS OF THE ADOPTED VERSION OF THE NATIONAL ELECTRICAL CODE, THE LOCAL POWER COMPANY AND TO ALL APPLICABLE LOCAL REGULATIONS.

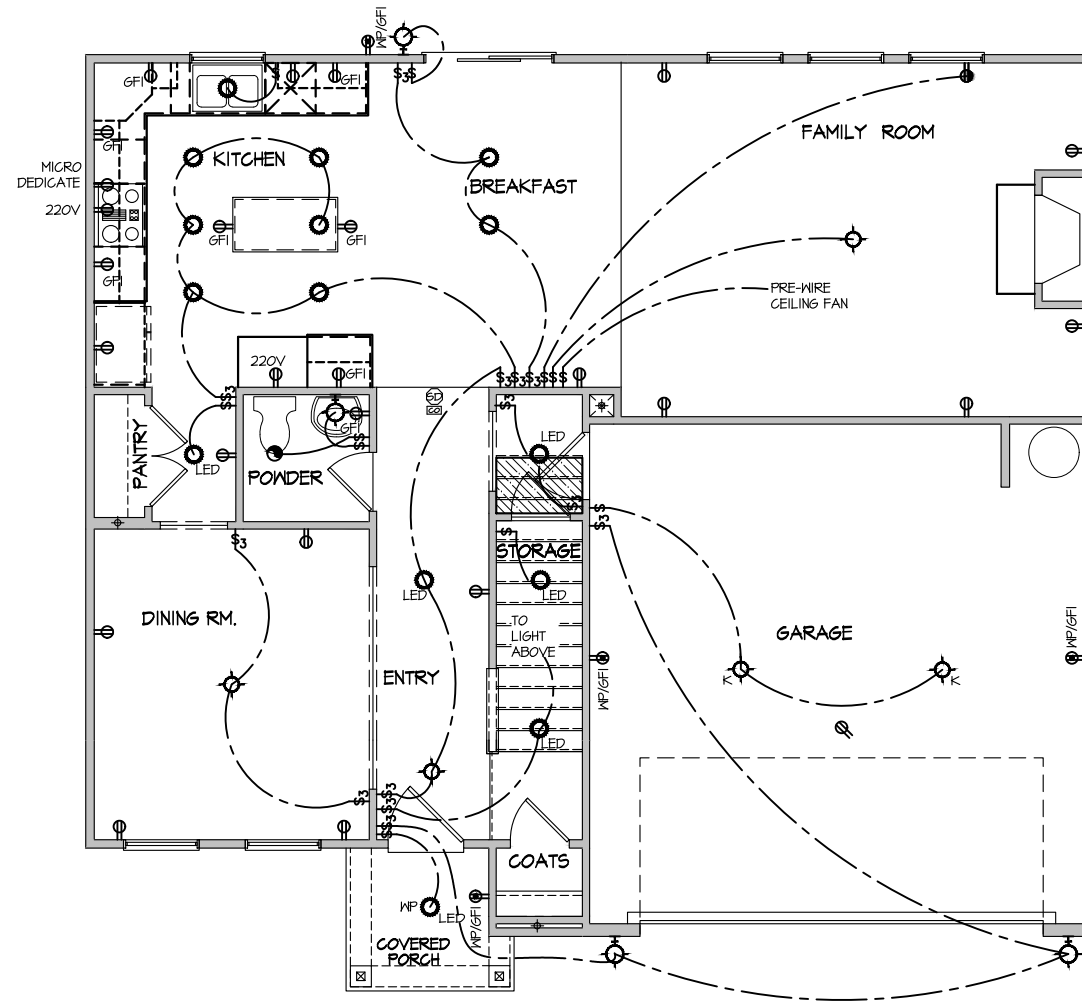

ELECTRICAL PLAN
FIRST FLOOR - ELEV. 1
 SCALE: 1/8" = 1'-0"

MASTER PLAN INFORMATION		UPDATED DATE
REVISION	DATE	12-21-2020
R3-RALE	08-23-2019	

DRAWN BY:	ITS
DATE:	06/07/2022
PLAN NO.	2223



HOUSE NAME:	ELMHURST
DRAWING TITLE	FIRST FLOOR ELECTRICAL

SHEET No.	E.1
-----------	-----

ELECTRICAL LEGEND

- Ⓢ SINGLE POLE SWITCH
- Ⓢ₃ THREE WAY SWITCH
- Ⓢ₄ FOUR WAY SWITCH
- Ⓢ- DUPLEX AFCI RECEPTACLE
- Ⓢ- DUPLEX AFCI RECEPTACLE - BOTTOM HALF SWITCHED
- Ⓢ- DUPLEX AFCI RECEPTACLE - FLOOR MOUNTED
- 220V Ⓢ RECEPTACLE - 220V
- Ⓢ- GFI DUPLEX AFCI RECEPTACLE - GFI
- Ⓢ- WP/GFI DUPLEX AFCI RECEPTACLE - WATERPROOF GFI
- Ⓢ- SMOKE DETECTOR - WIRED IN SERIES
- Ⓢ- EXHAUST FAN MOTOR
- Ⓢ- CO DETECTOR
- Ⓢ- DOOR CHIME
- Ⓢ- LIGHT FIXTURE - WALL MOUNTED
- Ⓢ- LIGHT FIXTURE - CEILING MOUNTED
- Ⓢ- LIGHT FIXTURE - RECESSED CAN
- Ⓢ- LED LIGHT FIXTURE - LED SURFACE MOUNTED
- Ⓢ- FULLCHAIN LAMPHOLDER
- Ⓢ- KEYLESS LAMPHOLDER

NOTE: ALL ELECTRICAL WORK SHALL CONFORM TO THE REQUIREMENTS OF THE ADOPTED VERSION OF THE NATIONAL ELECTRICAL CODE, THE LOCAL POWER COMPANY AND TO ALL APPLICABLE LOCAL REGULATIONS.

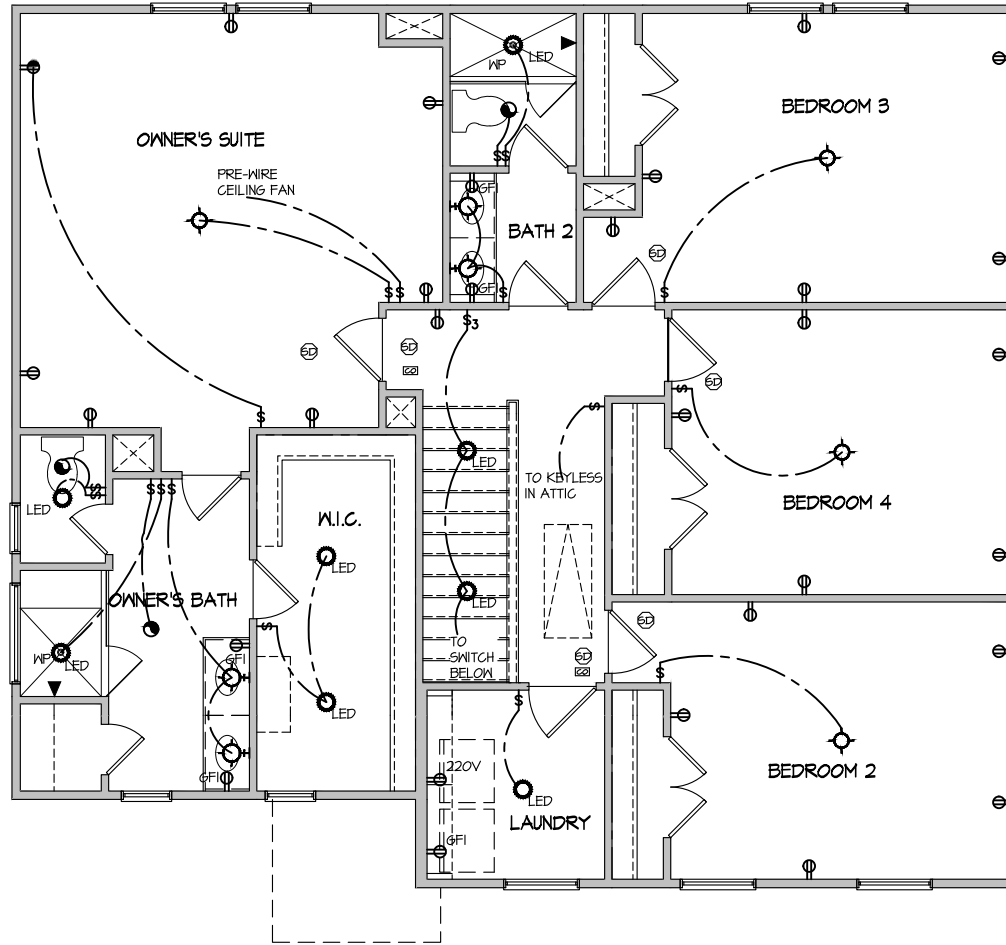

**ELECTRICAL PLAN
SECOND FLOOR - ELEV. 1**

SCALE: 1/8" = 1'-0"

MASTER PLAN INFORMATION	
REVISION	DATE
R3-RALE	08-23-2019
	12-21-2020

DRAWN BY: ITS
DATE: 06/07/2022
PLAN NO. 2223



HOUSE NAME: ELMHURST
DRAWING TITLE: SECOND FLOOR ELECTRICAL

SHEET No. E1.2

CONNECTION SPECIFICATIONS (TYP. U.N.O.)

Table with 3 columns: DESCRIPTION OF BLDG. ELEMENT, 3"x0.131" NAILS, 3"x0.120" NAILS. Rows include JOIST TO SOLE PLATE, SOLE PLATE TO JOIST/BLK'G, STUD TO SOLE PLATE, etc.

MEANS & METHODS NOTES

THE STRUCTURE IS DESIGNED TO BE SELF SUPPORTING AND STABLE AFTER THE BUILDING IS FINISHED AND ALL PLAN, DETAIL, AND NOTE SPECIFICATIONS HAVE BEEN COMPLETED.

STRUCTURAL DESIGN AND SPECIFICATIONS ASSUME THAT ALL SUPPORTING AND NON-SUPPORTING ELEMENTS IN CONTACT WITH FLOOR FRAMING ARE LEVEL.

ADDITIONAL NOTES FOR TRUSS & I-JOIST MANUFACTURER

ROOF TRUSSES, FLOOR TRUSSES AND ENGINEERED JOISTS SHALL BE DESIGNED TO MEET THE DIFFERENTIAL DEFLECTION CRITERIA BELOW UNLESS NOTED OTHERWISE ON PLAN.

GENERAL STRUCTURAL NOTES

- DESIGN IS BASED ON 2018 NORTH CAROLINA STATE BUILDING CODE, RESIDENTIAL CODE.
WOOD FRAME ENGINEERING IS BASED ON NDS, "NATIONAL DESIGN SPECIFICATION FOR WOOD CONSTRUCTION" - LATEST EDITION.

GENERAL FRAMING

- ALL TYP. NAIL FASTENER REQUIREMENTS ARE NOTED IN STANDARD CONNECTIONS TABLE OR ON PLANS. ALL NAILS SPECIFIED ARE MIN DIAMETER AND LENGTH REQUIRED FOR CONNECTION.

FLOOR FRAMING

- I-JOISTS/TRUSSES SHALL BE DESIGNED BY MANUF. TO MEET OR EXCEED L/480 LIVE LOAD DEFLECTION CRITERIA.
AT I-JOIST FLOORS, PROVIDE 1/8" MIN. OSB RIM BOARD.

ROOF FRAMING

- BAY WINDOWS & SHED ROOFS (UP TO 6' SPAN) CAN BE 2x4 OR 2x6 RAFTERS & CEILING JOISTS @ 16/24" O.C.
FASTEN EACH ROOF TRUSS TO TOP PLATE W/ SIMPSON H25T CLIP (OR APPROVED EQUAL) @ ALL BEARING POINTS.

LATERAL BRACING & SHEAR WALL SHEATHING SPECIFICATIONS

THIS MODEL HAS BEEN DESIGNED TO RESIST LATERAL FORCES RESULTING FROM: 120 MPH WIND IN 2018 NCSEBC:RC (120 MPH WIND SPEED IN ASCE 7-10 WIND MAP, PER IRC R301.2.1.1) EXP. B, RISK CAT. 2 & SEISMIC CAT. A/B.

THE DESIGN WAS COMPLETED PER 2015 IBC (SECTION 1609) & ASCE 7-10, AS PERMITTED BY R301.1.3 OF THE 2018 NCSEBC:RC, OR THE SIMPLIFIED PRESCRIPTIVE PROCEDURE IN ACCORDANCE WITH THE 2015 IRC IF THE PARAMETERS OF SECTION R602.12 COMPLY.

DESIGN WIND UPLIFT LOADS HAVE BEEN CALCULATED UTILIZING ASCE 7-10 (ACCEPTED ENGINEERING PRACTICE) AS ALLOWED PER 2018 NCSEBC:RC SECTION R802.11.1. THIS MODEL HAS BEEN DETAILED WHERE REQUIRED & ENGINEERED TO RESIST THE WIND UPLIFT LOAD PER SECTIONS R602.3.5 & R802.11.

EXT. WALL SHEATHING SPECIFICATION

- 1/16" OSB OR 15/32" PLYWOOD: FASTEN SHEATHING W/ 8d NAILS @ 6" O.C. AT EDGES & @ 12" O.C. IN THE PANEL FIELD. TYP. U.N.O.
HORIZONTAL BLOCKING OF EXT. WALL/SHEAR WALL PANEL EDGES IS NOT REQUIRED BY THIS DESIGN EXCEPT FOR THOSE AREAS SPECIFICALLY NOTED.

BLOCKED PANEL EDGES

- AT DESIGNATED AREAS - FASTEN SHEATHING W/ 8d NAILS @ 6" O.C. AT ALL PANEL EDGES AND 12" O.C. IN THE PANEL FIELD OR 1 3/4" 16 GA STAPLES (3/8" CROWN) @ 3" O.C. AT EDGES & @ 6" O.C. IN FIELD.

3" O.C. EDGE NAILING

- AT DESIGNATED AREAS - FASTEN PANEL EDGES OF WOOD STRUCTURAL WALL SHEATHING TO FRAMING W/ 8d NAILS @ 3" O.C. NO STAPLE ALTERNATIVE AVAILABLE AT THIS SPEC.

NOTES

- SEE CONNECTION SPECIFICATIONS CHART FOR STANDARD SHEAR TRANSFER DETAILING. IF ADDITIONAL CAPACITY IS REQUIRED BY DESIGN, IT WILL BE SPECIFICALLY NOTED ON PLAN.
DESIGN ASSUMES 16" O.C. MAX. STUD SPACING, U.N.O.

- INDICATES EXTENT OF INT. OSB SHEARWALL OR 3" O.C. OSB SHEARWALL.
INDICATES HOLD-DOWN BELOW

VENEER LINTEL SCHEDULE

Table with 3 columns: SPAN (MAX), HEIGHT OF VENEER ABOVE LINTEL, STEEL ANGLE SIZE. Rows include 3'-0", 6'-0", 8'-0", 9'-6", 16'-0".

ALL LINTELS:
SHALL SUPPORT 2 3/4" - 3 1/2" VENEER W/ 40 PPH MAXIMUM HEIGHT.
16" SHALL HAVE 4" MIN BEARING
18" SHALL HAVE 6" MIN BEARING

LEGEND

- INTERIOR BEARING WALL
BEARING WALL ABOVE
BEAM / HEADER
INDICATES SHEAR WALL & EXTENT
EXTENT OF OVERFRAMING
METAL HANGER
INDICATES POST ABOVE. PROVIDE SOLID BLOCKING UNDER POST OR JAMB ABOVE
INDICATES HOLD-DOWN OR STRAP. REFER TO SCHEDULE.

NON-BEARING HEADER SCHEDULE

Table with 3 columns: SPAN, 2x4 NON-BEARING PARTITION WALL, 2x6 NON-BEARING PARTITION WALL. Rows include UP TO 3'-0", UP TO 6'-0", UP TO 8'-0".

NOTES:
ALL NON-BEARING INTERIOR STUD WALLS SHALL BE CONSTRUCTED WITH 2x STUD GRADE MEMBERS SPACED @ 24" O.C. (MAX.)

HOLD-DOWN SCHEDULE

Table with 2 columns: SYMBOL, SPECIFICATION. Rows include HD-1 SIMPSON HIT4 HOLD-DOWN, HD-2 SIMPSON MSTC66 STRAP TIE, HD-3 SIMPSON 5THD4RJ HOLD-DOWN.

ALTERNATIVE TO 55TB24 ANCHOR BOLT SPECIFICATION:
UTILIZE SIMPSON "SET" EPOXY SYSTEM TO FASTEN 3/8" DIA. THREADED ROD INTO CONCRETE FOUNDATION.

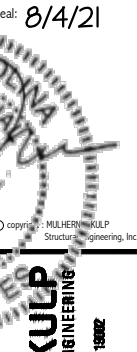

MULHERN+KULP
RESIDENTIAL STRUCTURAL ENGINEERING
300 Dunsmuir Ave., Building 4 - Asheville, PA 18002
717-648-8801 • mulhern@mkp.com

Project number: 126-21019

project mgr: JTR
drawn by: KL
issue date: 07-16-21

REVISIONS:
date: initial:



GENERAL NOTES
ELMHURST
RALEIGH, NC

SO.0

REFER TO SO.0 FOR
TYPICAL STRUCTURAL NOTES
& SCHEDULES

LEGEND

- [Symbol] INTERIOR BEARING WALL
- [Symbol] BEARING WALL ABOVE
- [Symbol] BEAM / HEADER
- [Symbol] INDICATES SHEAR WALL & EXTENT
- [Symbol] EXTENT OF OVERFRAMING
- [Symbol] 1L METAL HANGER
- [Symbol] INDICATES POST ABOVE. PROVIDE SOLID BLOCKING UNDER POST OR JAMB ABOVE.
- [Symbol] INDICATES HOLD-DOWN OR STRAP. REFER TO SCHEDULE.

NC LIC #C-3825

MULHERN+KULP
RESIDENTIAL STRUCTURAL ENGINEERING
3101 Darnside Ave, Building 4 - Auckler, PA 15002
P: 715-948-8001 • mulhern+kulp.com

M&K project number:	126-21019
project mgr:	JTR
drawn by:	KL
issue date:	07-16-21
REVISIONS:	
date:	initial:

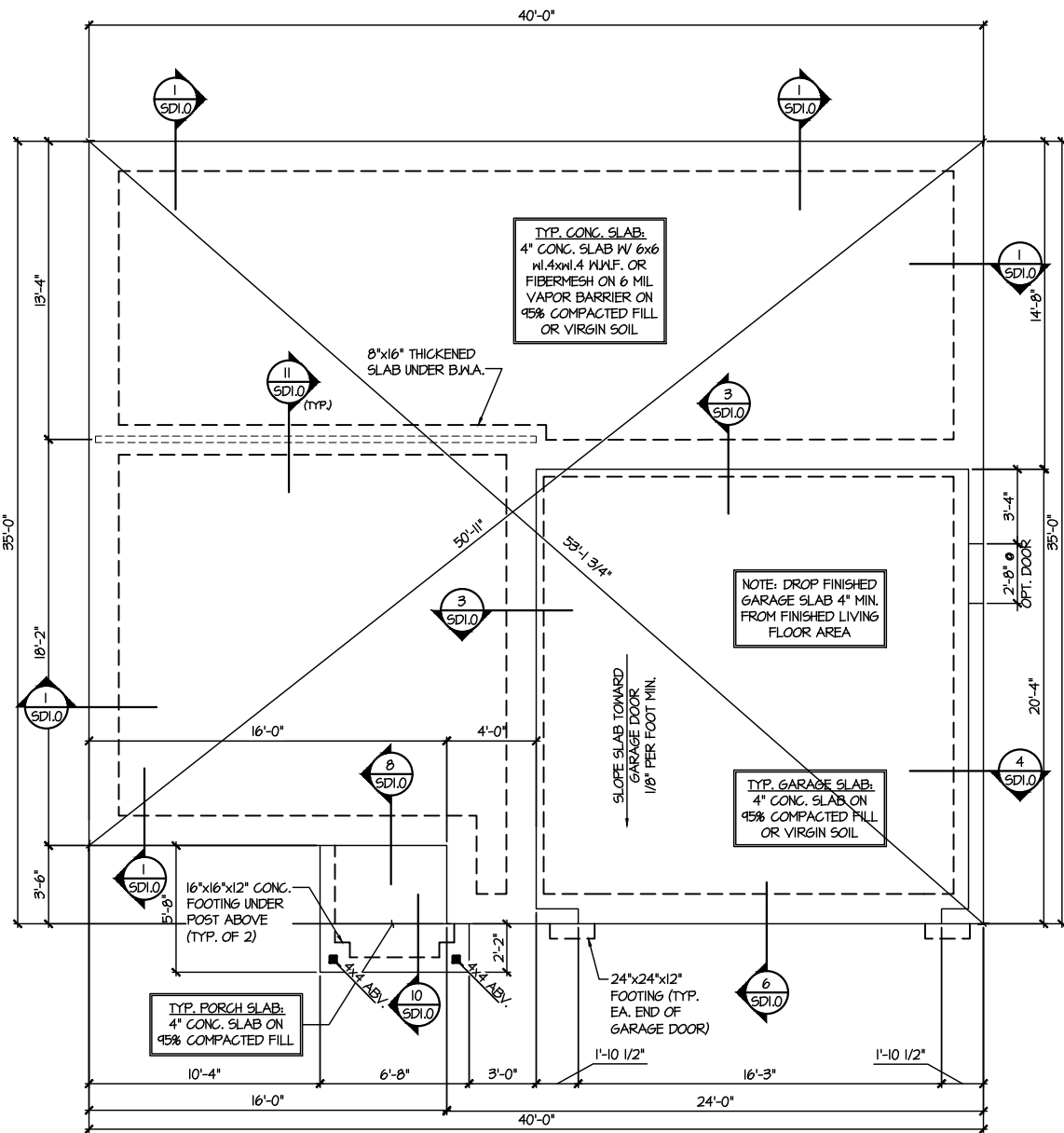

1 MONO SLAB FOUNDATION PLAN
SCALE: 1/8"=1'-0"
ELEVATION #1
ELEVATION #2 SIM.

FOUNDATION PLANS
ELMHURST
RALEIGH, NC

REFER TO 50.0 FOR
TYPICAL STRUCTURAL NOTES
& SCHEDULES

SD2.0 & SD2.1 REFERS TO SD2.0J
& SD2.1J FOR I-JOIST FLOOR
FRAMING OR SD2.0T & SD2.1T
FOR TRUSS FLOOR FRAMING

SD2.1J/SD2.1T REFERS TO
SD2.1JA/SD2.1TA FOR LVL/PSL/LSL
BEAMS OR SD2.1JB/SD2.1TB FOR
FLITCH BEAMS OR
SD2.1JC/SD2.1TC FOR STEEL
BEAMS

ENGINEERED BEAM MATERIAL SCHEDULE

BEAM NUMBER	LVL OPTION	PSL OPTION	LSL OPTION	FLITCH OPTION	STEEL OPTION
001	(2) 3/4"x14" - F	3/2"x14" - F	(2) 3/4"x14" - F	(2) 2x12 + (1) 3/4"x14" STEEL FLITCH PLATES - F	W12x14 - F
002	(2) 3/4"x14" - F	3/2"x14" - F	(2) 3/4"x14" - F	(2) 2x12 + (1) 3/4"x14" STEEL FLITCH PLATES - F	W12x14 - F
003	(3) 3/4"x16" - H	1"x16" - H	N/A	(3) 2x12 + (2) 3/4"x14" STEEL FLITCH PLATES - H	N/A
004	(3) 3/4"x20" - H	N/A	N/A	N/A	N/A
005	(2) 3/4"x14" - F	3/2"x14" - F	(2) 3/4"x14" - F	(2) 2x12 + (1) 3/4"x14" STEEL FLITCH PLATES - F	W12x14 - F
006	(2) 3/4"x14" - F	3/2"x14" - F	(2) 3/4"x14" - F	(2) 2x12 + (1) 3/4"x14" STEEL FLITCH PLATES - F	W12x14 - F
007	(2) 3/4"x24" - FT OR (3) 3/4"x22" - FT	N/A	N/A	N/A	W14x34 - F
008	(2) 3/4"x14" - F	3/2"x14" - F	(2) 3/4"x14" - F	(2) 2x12 + (1) 3/4"x14" STEEL FLITCH PLATES - F	W12x14 - F
009	(2) 3/4"x14" - F	3/2"x14" - F	N/A	(2) 2x12 + (1) 3/4"x14" STEEL FLITCH PLATES - F	W12x14 - F
010	(2) 3/4"x14" - F	3/2"x14" - F	(3) 3/4"x14" - F	(2) 2x12 + (1) 3/4"x14" STEEL FLITCH PLATES - F	W12x14 - F

- BEAM NOTATION:
 - "F" INDICATES FLUSH BEAM
 - "FT" INDICATES FLUSH TOP BEAM
 - "FB" INDICATES FLUSH BOTTOM BEAM
 - "D" INDICATES DROPPED BEAM
 - "H" INDICATES DROPPED OPENING HEADER
- REFER TO DETAIL D/SD2.0 FOR TYPICAL FLITCH BEAM CONNECTIONS
- REFER TO DETAIL E/SD2.0 FOR TYPICAL STEEL BEAM CONNECTIONS
- FOR FLUSH TOP BEAMS PROVIDE 2X STACKED PLATES BENEATH BEAM AS REQ'D. FASTEN PLATES IN SUCCESSION W/ (2) 3"x0.120" NAILS @ 8" O.C.
- FOR FLUSH BOTTOM BEAMS PROVIDE 2X STACKED PLATES ATOP BEAM AS REQ'D. FASTEN PLATES IN SUCCESSION W/ (2) 3"x0.120" NAILS @ 8" O.C.

LEGEND

- INTERIOR BEARING WALL
- BEARING WALL ABOVE
- BEAM / HEADER
- INDICATES SHEAR WALL & EXTENT
- EXTENT OF OVERFRAMING
- METAL HANGER
- INDICATES POST ABOVE. PROVIDE SOLID BLOCKING UNDER POST OR JAMB ABOVE.
- INDICATES HOLD-DOWN OR STRAP. REFER TO SCHEDULE.

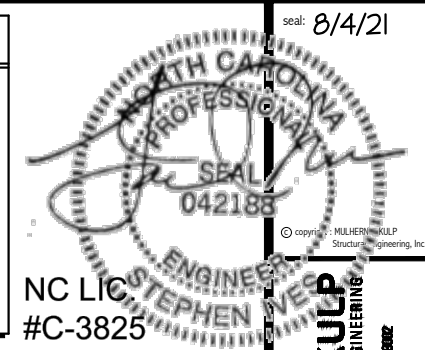

NC LIC #C-3825

Scale: 8/4/21

MULHERN+KULP
RESIDENTIAL STRUCTURAL ENGINEERING
300 Darnside Ave, Building 4 - Amber, PA 15002
P: 717-548-8001 • mulhern+kulp.com

M&K project number:
126-21019
project mgr: JTR
drawn by: KL
issue date: 07-16-21

REVISIONS:
date: initial:

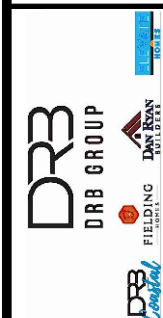

FLOOR FRAMING PLANS
ELMHURST
RALEIGH, NC

sheet: RIGHT HAND

S3.0J

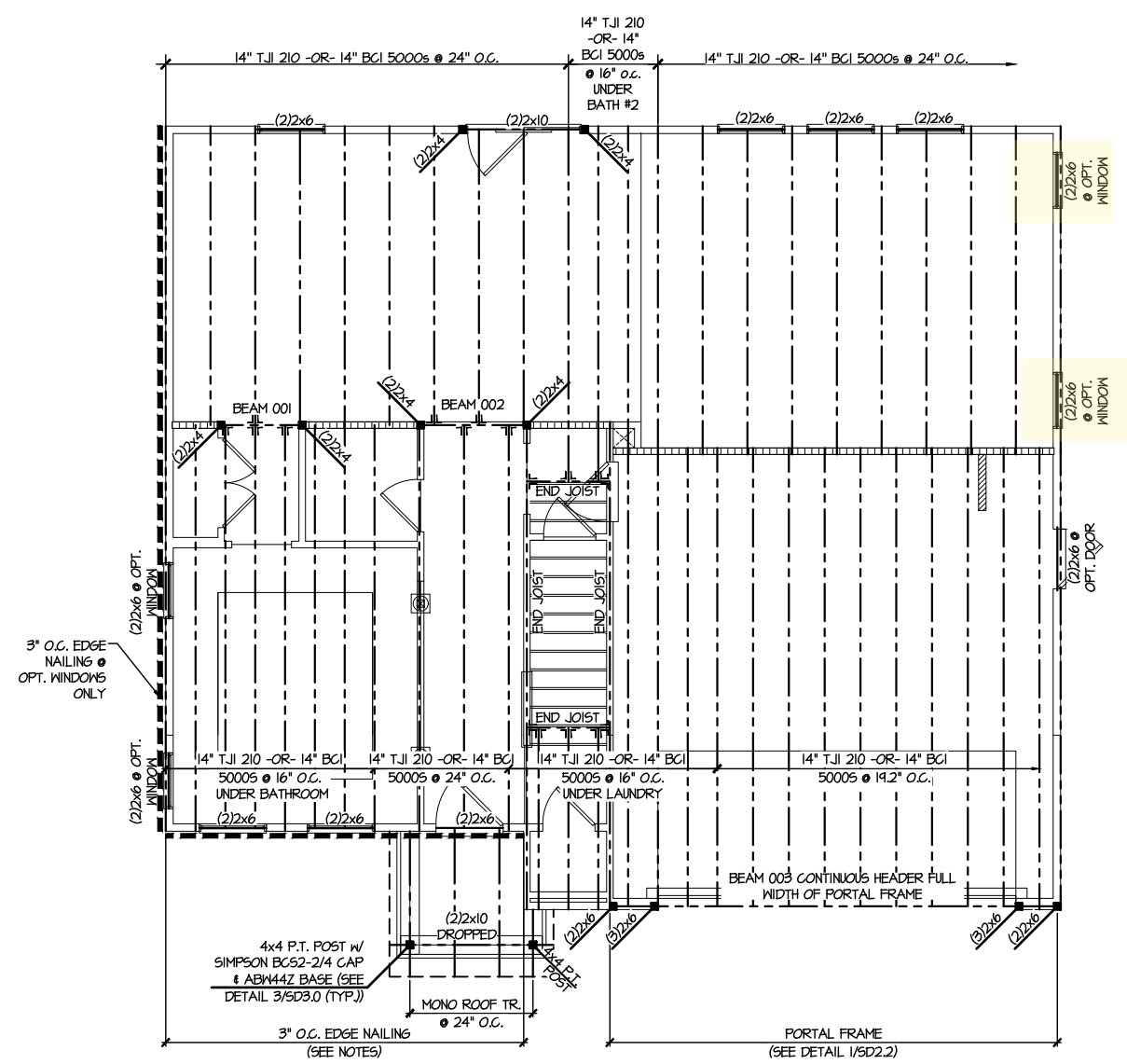

2ND FLOOR FRAMING PLAN
SCALE: 1/8"=1'-0"
ELEVATION #1

REFER TO 50.0 FOR
TYPICAL STRUCTURAL NOTES
& SCHEDULES

SD2.0 & SD2.1 REFERS TO SD2.0J
& SD2.1J FOR I-JOIST FLOOR
FRAMING OR SD2.0T & SD2.1T
FOR TRUSS FLOOR FRAMING

SD2.1J/SD2.1T REFERS TO
SD2.1JA/SD2.1TA FOR LVL/PSL/LSL
BEAMS OR SD2.1JB/SD2.1TB FOR
FLITCH BEAMS OR
SD2.1JC/SD2.1TC FOR STEEL
BEAMS

ENGINEERED BEAM MATERIAL SCHEDULE

BEAM NUMBER	LVL OPTION	PSL OPTION	LSL OPTION	FLITCH OPTION	STEEL OPTION
001	(2)3/4"x14" - F	3/2"x14" - F	(2)3/4"x14" - F	(2)2x12 + (1)3/4"x14" STEEL FLITCH PLATES - F	W12x14 - F
002	(2)3/4"x14" - F	3/2"x14" - F	(2)3/4"x14" - F	(2)2x12 + (1)3/4"x14" STEEL FLITCH PLATES - F	W12x14 - F
003	(3)3/4"x16" - H	1"x16" - H	N/A	(3)2x12 + (2)3/4"x14" STEEL FLITCH PLATES - H	N/A
004	(3)3/4"x20" - H	N/A	N/A	N/A	N/A
005	(2)3/4"x14" - F	3/2"x14" - F	(2)3/4"x14" - F	(2)2x12 + (1)3/4"x14" STEEL FLITCH PLATES - F	W12x14 - F
006	(2)3/4"x14" - F	3/2"x14" - F	(2)3/4"x14" - F	(2)2x12 + (1)3/4"x14" STEEL FLITCH PLATES - F	W12x14 - F
007	(2)3/4"x24" - FT OR (3)3/4"x22" - FT	N/A	N/A	N/A	W14x34 - F
008	(2)3/4"x14" - F	3/2"x14" - F	(2)3/4"x14" - F	(2)2x12 + (1)3/4"x14" STEEL FLITCH PLATES - F	W12x14 - F
009	(2)3/4"x14" - F	3/2"x14" - F	N/A	(2)2x12 + (1)3/4"x14" STEEL FLITCH PLATES - F	W12x14 - F
010	(2)3/4"x14" - F	3/2"x14" - F	(3)3/4"x14" - F	(2)2x12 + (1)3/4"x14" STEEL FLITCH PLATES - F	W12x14 - F

- BEAM NOTATION:
 - "F" INDICATES FLUSH BEAM
 - "FT" INDICATES FLUSH TOP BEAM
 - "FB" INDICATES FLUSH BOTTOM BEAM
 - "D" INDICATES DROPPED BEAM
 - "H" INDICATES DROPPED OPENING HEADER
- REFER TO DETAIL D/SD2.0 FOR TYPICAL FLITCH BEAM CONNECTIONS
- REFER TO DETAIL E/SD2.0 FOR TYPICAL STEEL BEAM CONNECTIONS
- FOR FLUSH TOP BEAMS PROVIDE 2X STACKED PLATES BENEATH BEAM AS REQ'D. FASTEN PLATES IN SUCCESSION W (2) 3"x0.120" NAILS @ 8" O.C.
- FOR FLUSH BOTTOM BEAMS PROVIDE 2X STACKED PLATES ATOP BEAM AS REQ'D. FASTEN PLATES IN SUCCESSION W (2) 3"x0.120" NAILS @ 8" O.C.

LEGEND

- INTERIOR BEARING WALL
- BEARING WALL ABOVE
- BEAM / HEADER
- INDICATES SHEAR WALL & EXTENT
- EXTENT OF OVERFRAMING
- METAL HANGER
- INDICATES POST ABOVE. PROVIDE SOLID BLOCKING UNDER POST OR JAMB ABOVE.
- INDICATES HOLD-DOWN OR STRAP. REFER TO SCHEDULE.

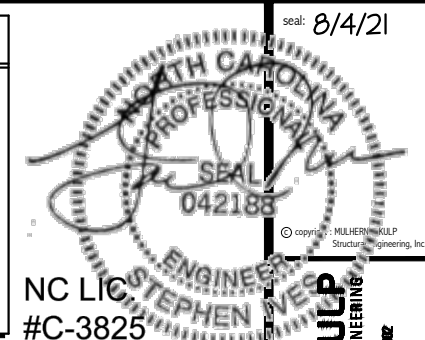

NC LIC #C-3825

Scale: 8/4/21

MULHERN+KULP
RESIDENTIAL STRUCTURAL ENGINEERING
300 Darnside Ave, Building 4 - Asheville, PA 18002
P: 715-648-8801 • mulhernkulp.com

M&K project number:
126-21019

project mgr: JTR
drawn by: KL
issue date: 07-16-21

REVISIONS:
date: initial:

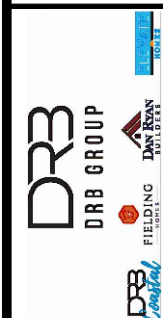

FLOOR FRAMING PLANS
ELMHURST
RALEIGH, NC

sheet: RIGHT HAND
S3.0T

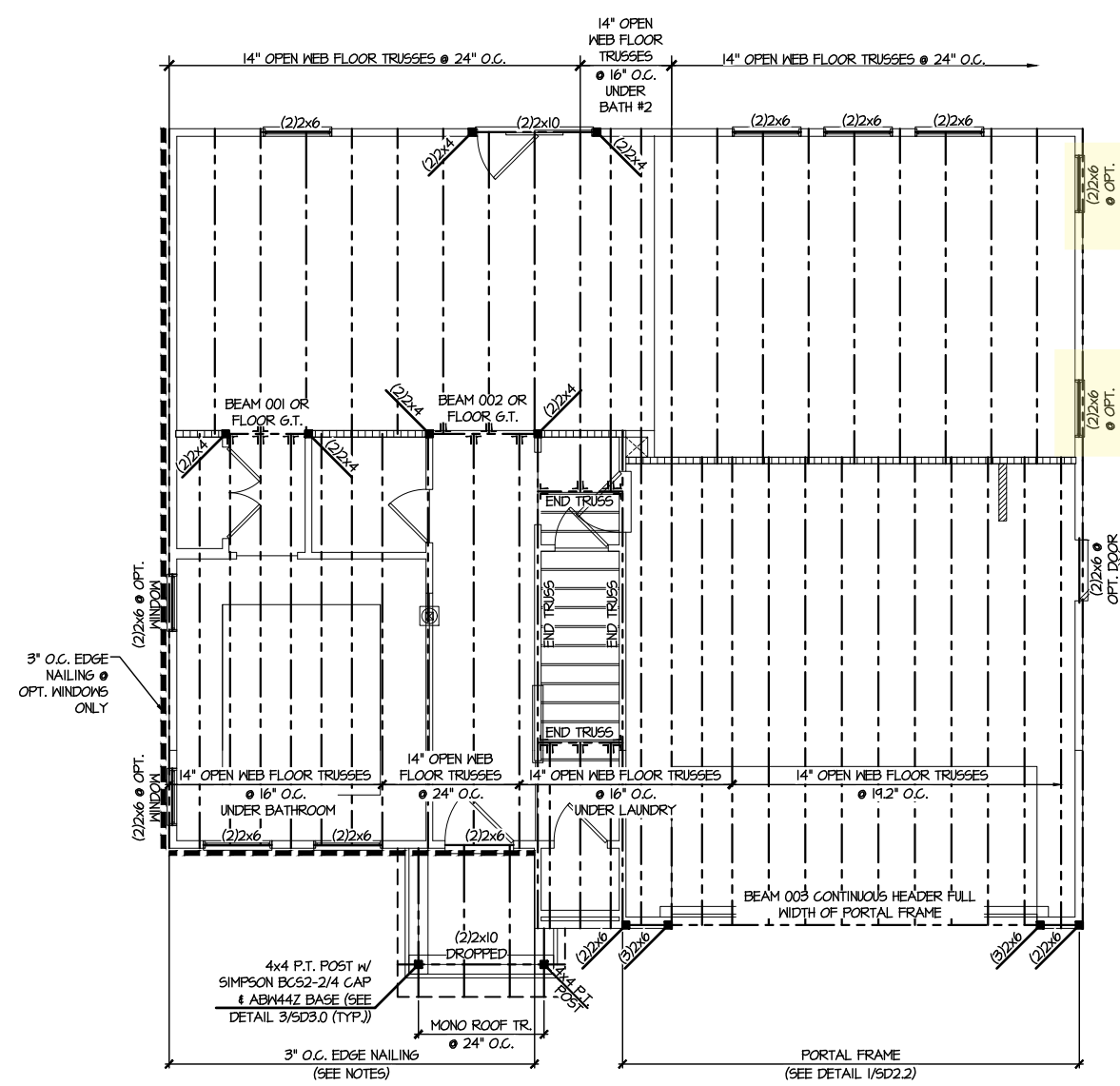

2ND FLOOR FRAMING PLAN
SCALE: 1/8"=1'-0"
ELEVATION #1

REFER TO SO.0 FOR
TYPICAL STRUCTURAL NOTES
& SCHEDULES

LEGEND

- [Symbol] INTERIOR BEARING WALL
- [Symbol] BEARING WALL ABOVE
- [Symbol] BEAM / HEADER
- [Symbol] INDICATES SHEAR WALL & EXTENT
- [Symbol] EXTENT OF OVERFRAMING
- [Symbol] METAL HANGER
- * INDICATES POST ABOVE. PROVIDE SOLID BLOCKING UNDER POST OR JAMB ABOVE.
- ▶ INDICATES HOLD-DOWN OR STRAP. REFER TO SCHEDULE.

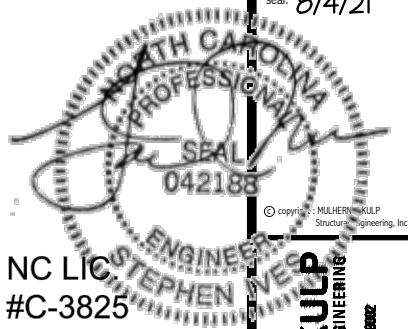

NC LIC #C-3825

MULHERN+KUIP
RESIDENTIAL STRUCTURAL ENGINEERING
300 Darnside Ave, Building 4 - Ashebor, PA 15082
P: 715-948-8001 • mulhernkuip.com

M&K project number:
126-21019

project mgr: JTR
drawn by: KL
issue date: 07-16-21

REVISIONS:

date:	initial:



ROOF FRAMING PLANS
ELMHURST
RALEIGH, NC

sheet: RIGHT HAND
S4.0

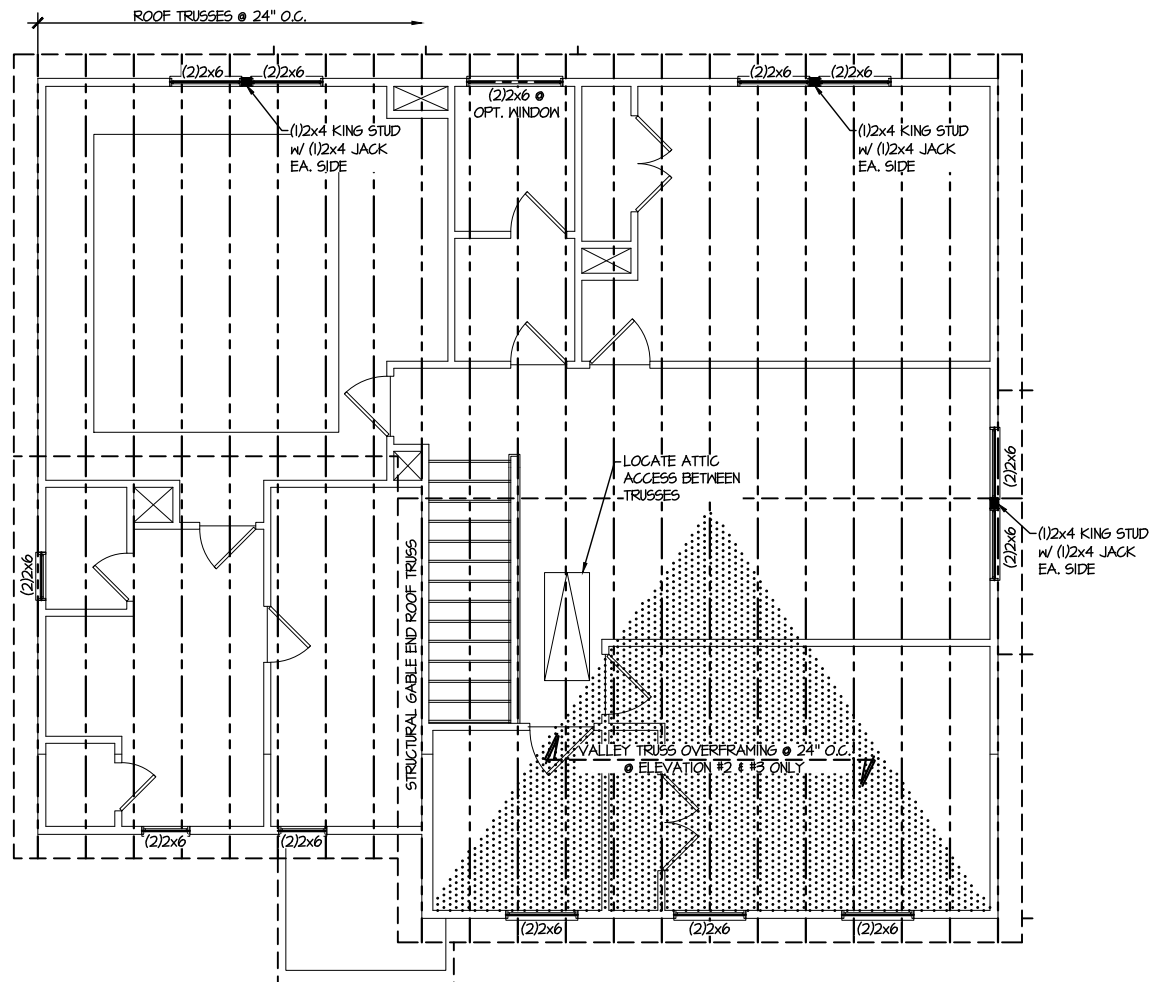

1 ROOF FRAMING PLAN
SCALE: 1/8"=1'-0" ELEV. #1 SHOWN - ELEV. #2, #3 SIM.

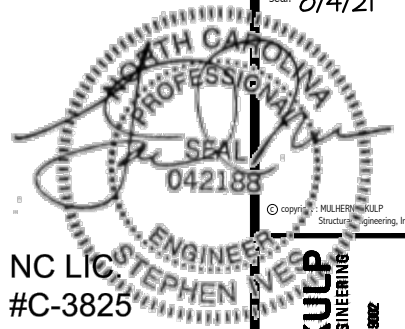

NC LICENSE #C-3825

MULHERN+KULP
RESIDENTIAL STRUCTURAL ENGINEERING
300 Dunsmuir Ave., Building 4 - Asheville, PA 18002
p.715.648.8001 • mulhernkulp.com



M&K project number:
126-21019
project mgr: JTR
drawn by: KL
issue date: 07-16-21

REVISIONS:
date: initial:



MONO SLAB DETAILS
ELMHURST
RALEIGH, NC

sheet:
SD1.0

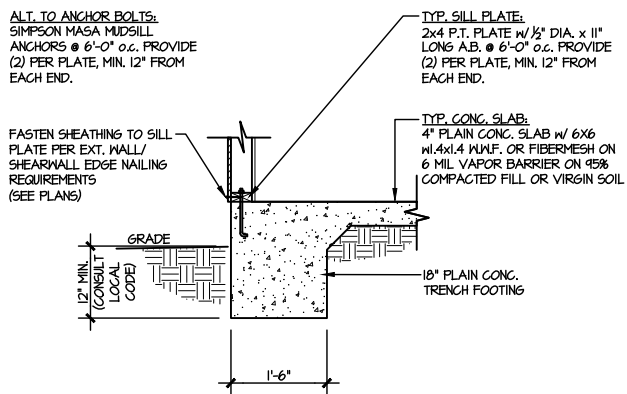

1 TYPICAL SLAB ON GRADE PERIMETER FOOTING
SCALE: 3/8"=1'-0"

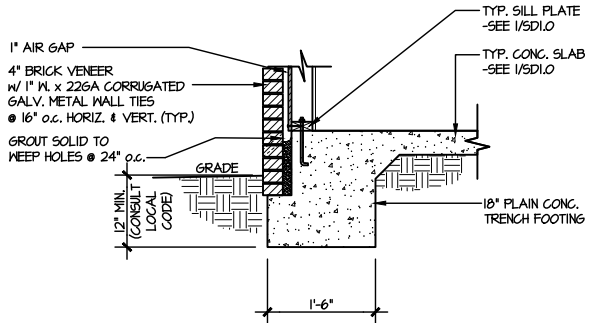

2 TYPICAL SLAB ON GRADE PERIMETER FOOTING
SCALE: 3/8"=1'-0" w/ BRICK VENEER

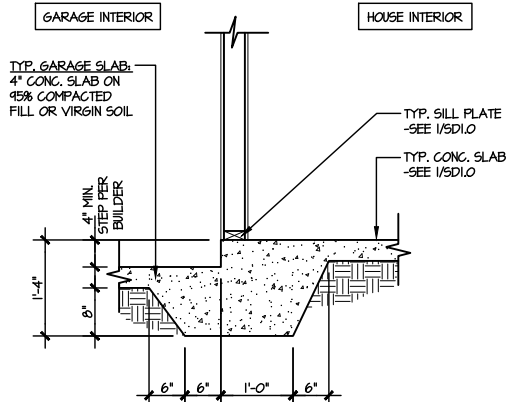

3 TYPICAL MONOLITHIC INTERIOR GARAGE FOOTING
SCALE: 3/8"=1'-0"

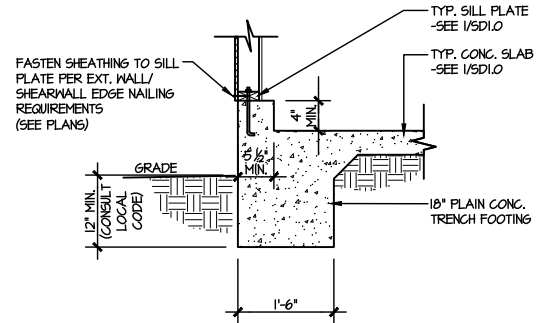

4 TYPICAL SLAB ON GRADE GARAGE PERIMETER FOOTING
SCALE: 3/8"=1'-0"

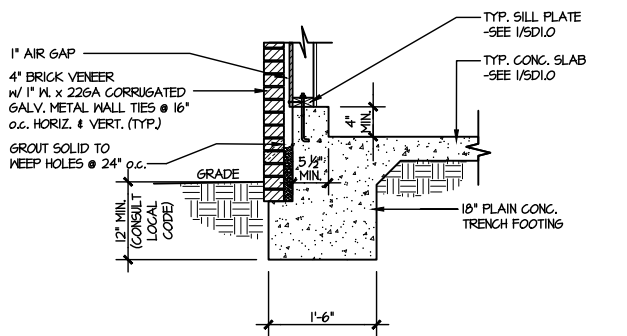

5 TYPICAL SLAB ON GRADE GARAGE PERIMETER FOOTING
SCALE: 3/8"=1'-0" w/ BRICK VENEER

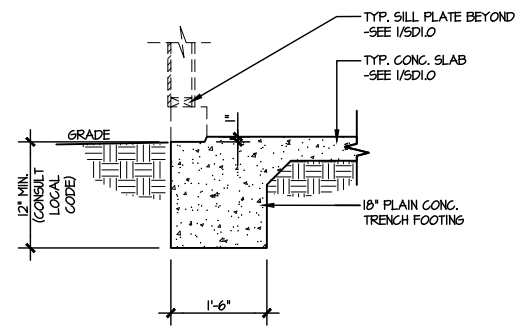

6 TYPICAL SLAB ON GRADE GARAGE ENTRY @ PERIMETER FOOTING
SCALE: 3/8"=1'-0"

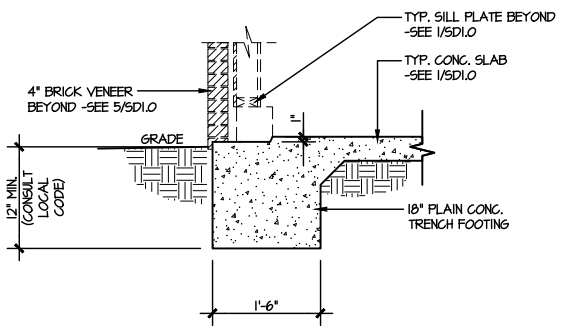

7 TYPICAL SLAB ON GRADE GARAGE ENTRY @ PERIMETER FOOTING
SCALE: 3/8"=1'-0" w/ BRICK VENEER

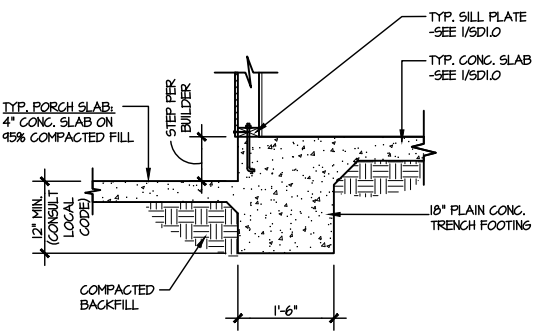

8 TYPICAL SLAB ON GRADE PERIMETER FOOTING @ PORCH/PATIO
SCALE: 3/8"=1'-0"

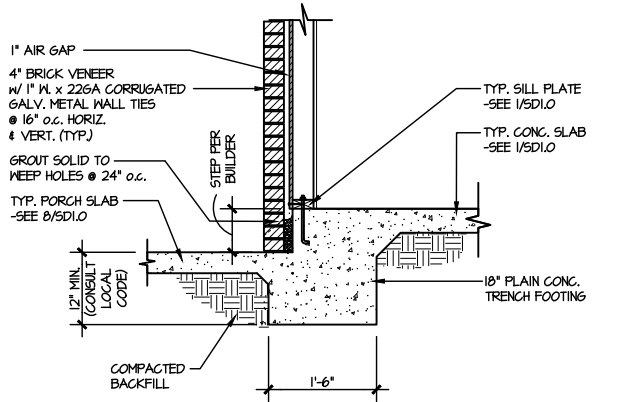

9 TYPICAL SLAB ON GRADE PERIMETER FOOTING @ PORCH/PATIO
SCALE: 3/8"=1'-0" w/ BRICK VENEER

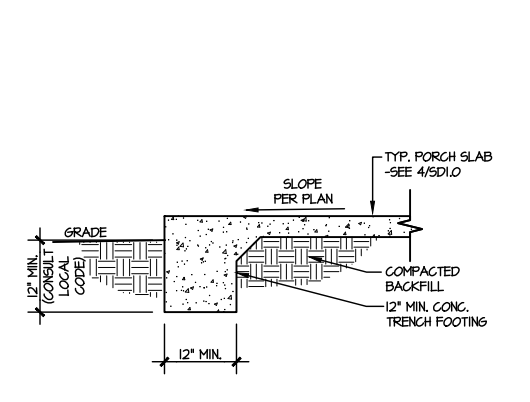

10 TYPICAL FOOTING @ PORCH SLAB
SCALE: 3/8"=1'-0"

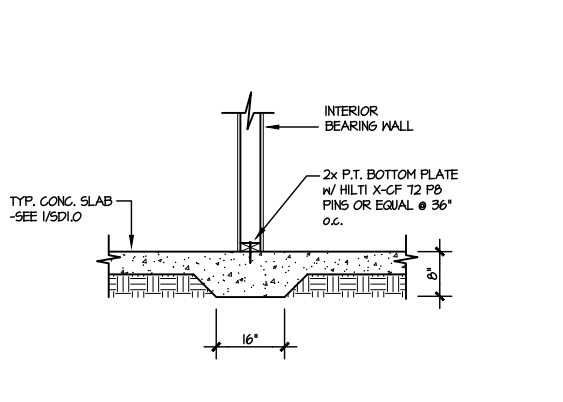

11 TYPICAL THICKENED SLAB @ INTERIOR BEARING WALL
SCALE: 3/8"=1'-0"

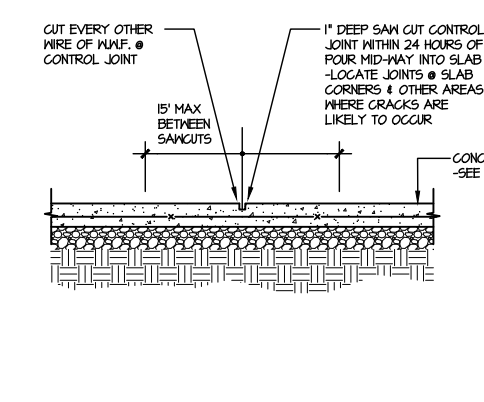

A TYPICAL CONTROL JOINT
SCALE: 3/8"=1'-0"
LOCATE @ 15'-0" MAX OR CORNERS WHERE CRACKS LIKELY TO DEVELOP

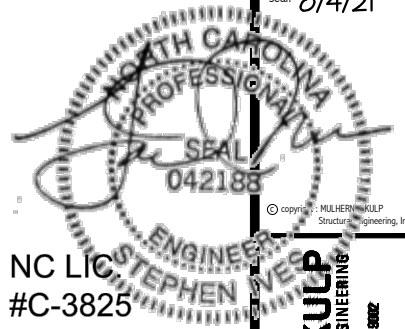

NC LIC #C-3825

MULHERN+KUIP
RESIDENTIAL STRUCTURAL ENGINEERING
300 Dunsmuir Ave, Building 4 - Asheville, PA 18002
P: 715-548-5801 • mulhernkuip.com



M&K project number:
126-21019

project mgr: JTR
drawn by: KL
issue date: 07-16-21

REVISIONS:
date: initial:



FRAMING DETAILS
ELMHURST
RALEIGH, NC

sheet:
SD2.0J

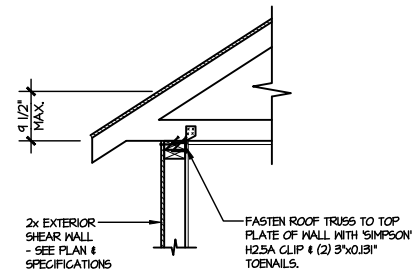

A1 TYPICAL SHEAR
TRANSFER DETAIL @ ROOF
SCALE: 3/8"=1'-0"
HEEL HEIGHT LESS THAN 4 1/2'
NO BLOCKING REQ'D

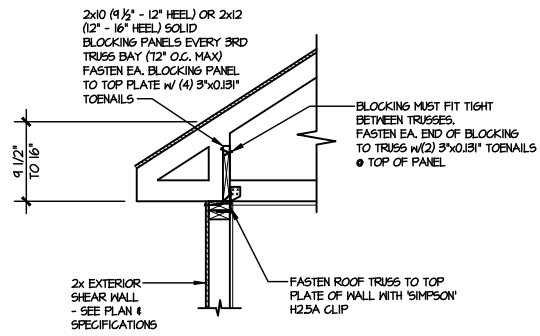

A2 TYPICAL SHEAR
TRANSFER DETAIL @ ROOF
SCALE: 3/8"=1'-0"
HEEL HEIGHT BETWEEN 4 1/2' - 16'
BLOCKING REQ'D

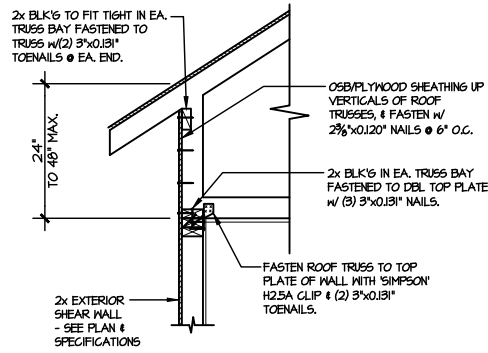

A3 TYPICAL SHEAR
TRANSFER DETAIL @ RAISED HEEL TRUSS
SCALE: 3/8"=1'-0"
HEEL HEIGHT UP TO 48' MAX.

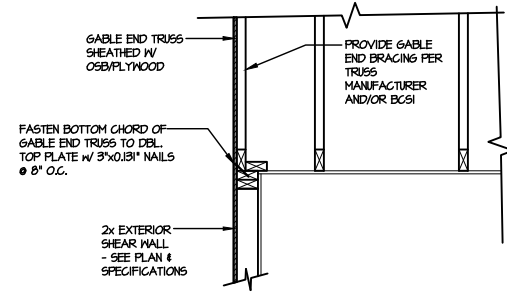

B TYPICAL GABLE END DETAIL
SCALE: 3/8"=1'-0"

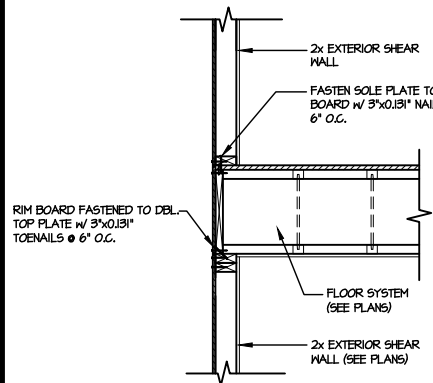

C TYPICAL SHEAR
TRANSFER DETAIL
BETWEEN FLOORS @ EXTERIOR WALL
SCALE: 3/8"=1'-0"

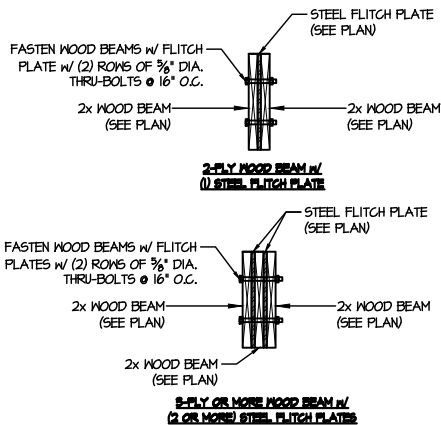

D TYPICAL FLITCH BEAM CONNECTION DETAIL
SCALE: 3/4"=1'-0"

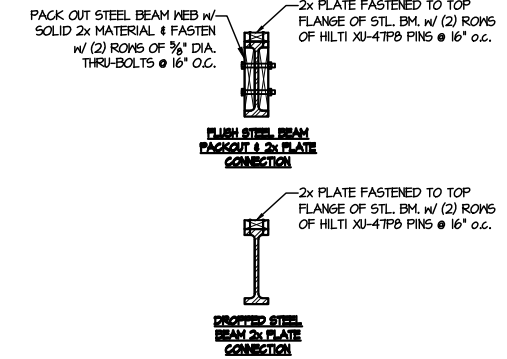

E TYPICAL STEEL BEAM CONNECTION DETAIL
SCALE: 3/4"=1'-0"

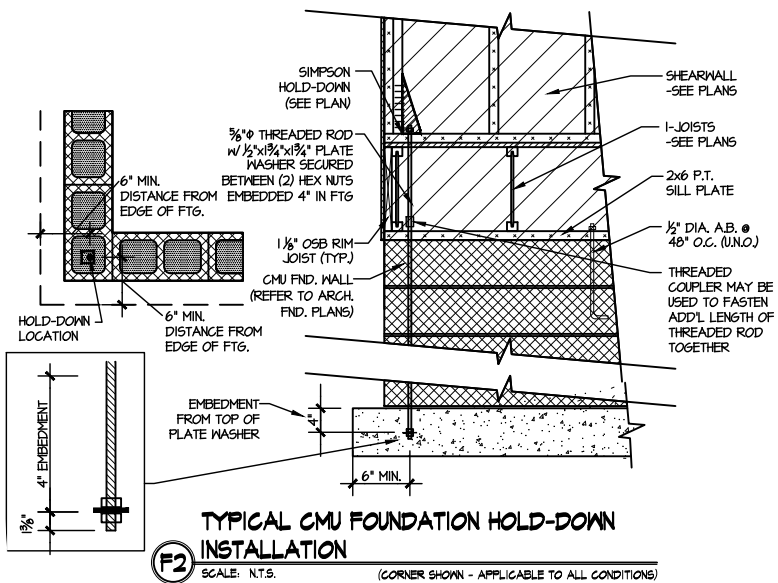

F2 TYPICAL CMU FOUNDATION HOLD-DOWN
INSTALLATION
SCALE: N.T.S.
(CORNER SHOWN - APPLICABLE TO ALL CONDITIONS)

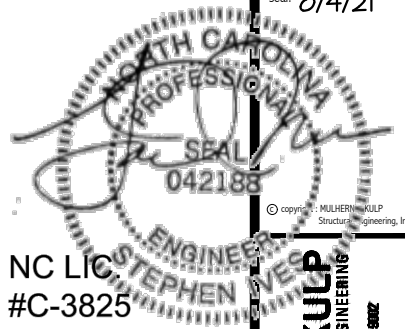

MULHERN+KULP
RESIDENTIAL STRUCTURAL ENGINEERING
300 Duneside Ave, Building 4 - Annapolis, PA 19802
P: 715-948-8801 • mulhern@mkp.com

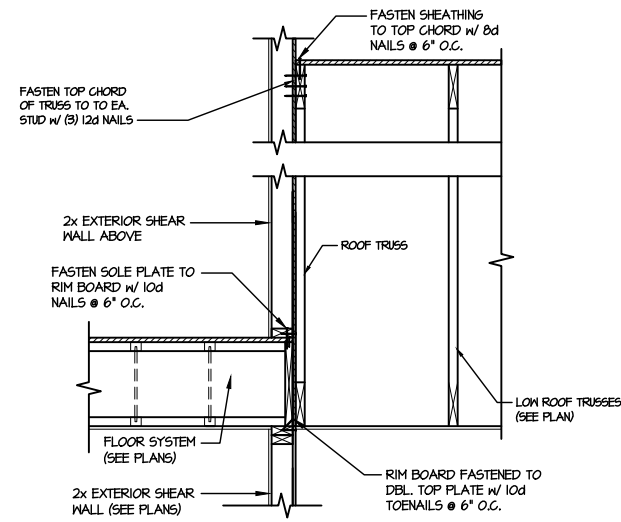

1 TYPICAL SHEAR TRANSFER DETAIL BETWEEN FLOORS @ INTERIOR WALL
SCALE: 3/4\"/>

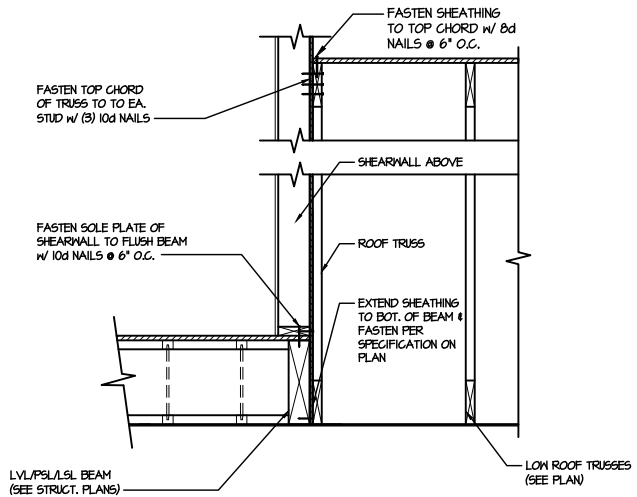

2 SHEAR TRANSFER DETAIL @ EXTERIOR SHEARWALL ABOVE
SCALE: 3/4\"/>

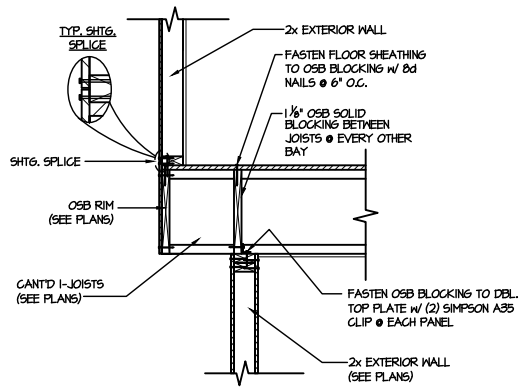

3 SHEAR TRANSFER DETAIL BETWEEN FLOORS @ CANT'D EXT. WALL
SCALE: 3/4\"/>

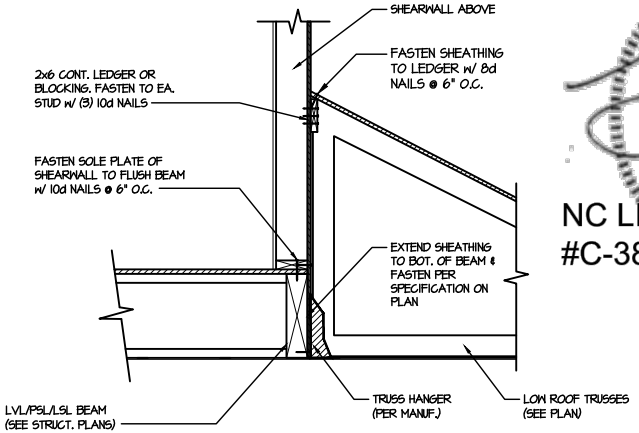

4 SHEAR TRANSFER DETAIL @ EXTERIOR SHEARWALL ABOVE
SCALE: 3/4\"/>

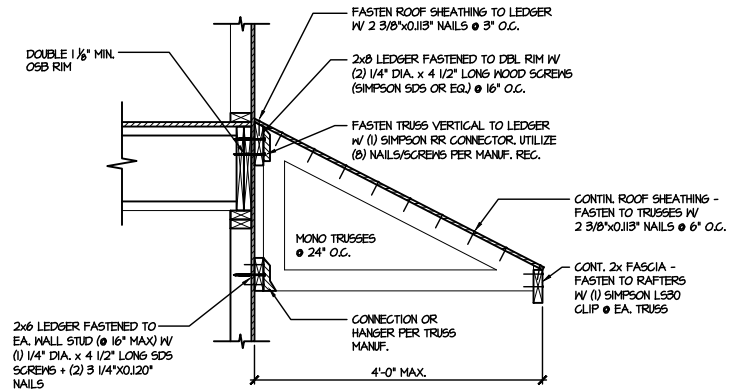

5 DETAIL @ SHED ROOF
SCALE: 3/8\"/>

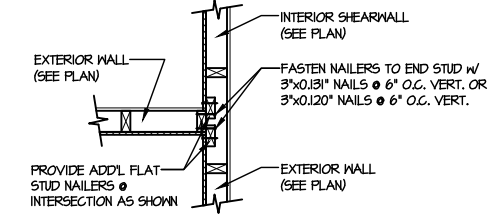

6 SHEAR TRANSFER DETAIL @ INTERSECTING INT. SHEARWALL
SCALE: 3/4\"/>

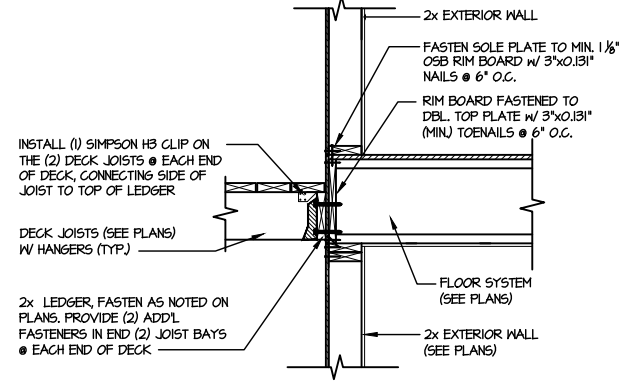

7 DECK CONNECTION DETAIL
SCALE: 3/4\"/>

M&K project number:
126-21019
project mgr: JTR
drawn by: KL
issue date: 07-16-21

REVISIONS:

date:	initial:



FRAMING DETAILS
ELMHURST
RALEIGH, NC

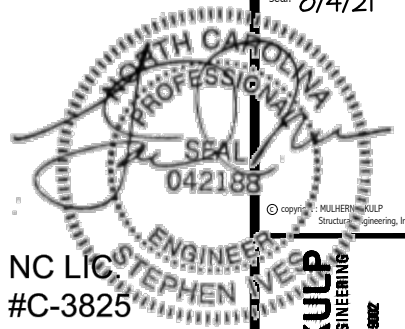

MULHERN+KULP
RESIDENTIAL STRUCTURAL ENGINEERING
300 Duneside Ave. Building 4 - Asheville, PA 18027
975-948-8801 • mulhern+kulp.com



M&K project number:
126-21019
project mgr: JTR
drawn by: KL
issue date: 07-16-21
REVISIONS:
date: initial:



FRAMING DETAILS
ELMHURST
RALEIGH, NC

sheet:
SD2.1BJ

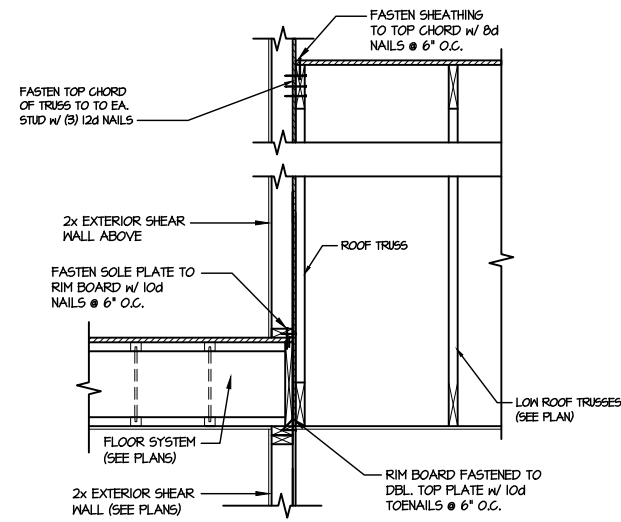

1 TYPICAL SHEAR TRANSFER DETAIL BETWEEN FLOORS @ INTERIOR WALL
SCALE: 3/4\"/>

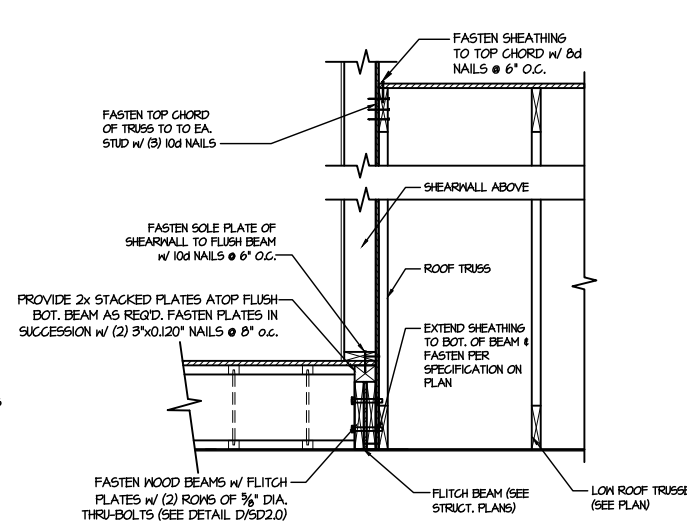

2 SHEAR TRANSFER DETAIL @ EXTERIOR SHEARWALL ABOVE
SCALE: 3/4\"/>

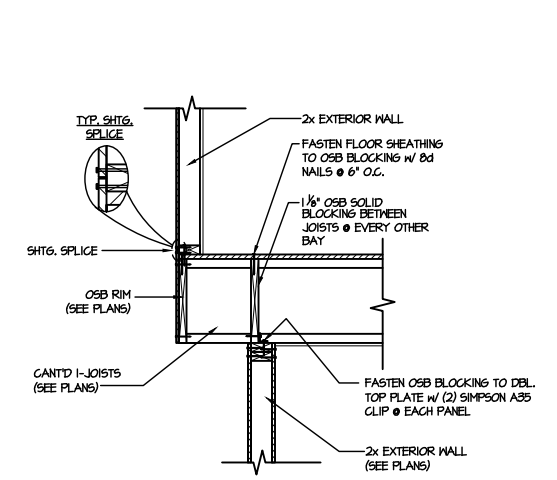

3 SHEAR TRANSFER DETAIL BETWEEN FLOORS @ CANT'D EXT. WALL
SCALE: 3/4\"/>

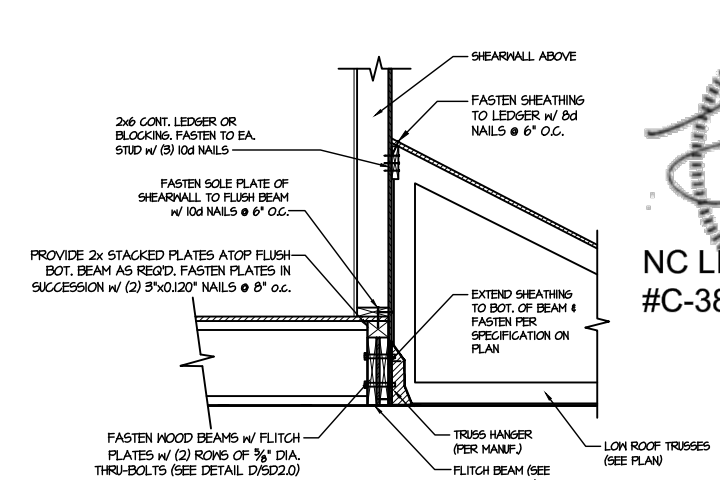

4 SHEAR TRANSFER DETAIL @ EXTERIOR SHEARWALL ABOVE
SCALE: 3/4\"/>

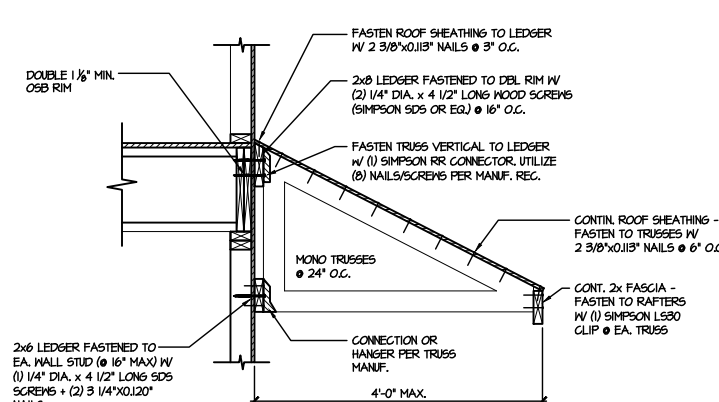

5 DETAIL @ SHED ROOF
SCALE: 3/8\"/>

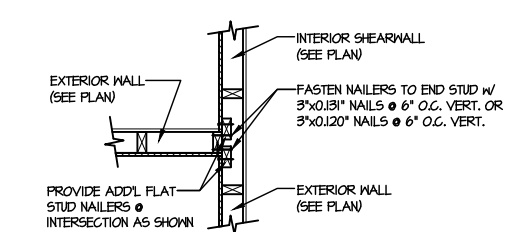

6 SHEAR TRANSFER DETAIL @ INTERSECTING INT. SHEARWALL
SCALE: 3/4\"/>

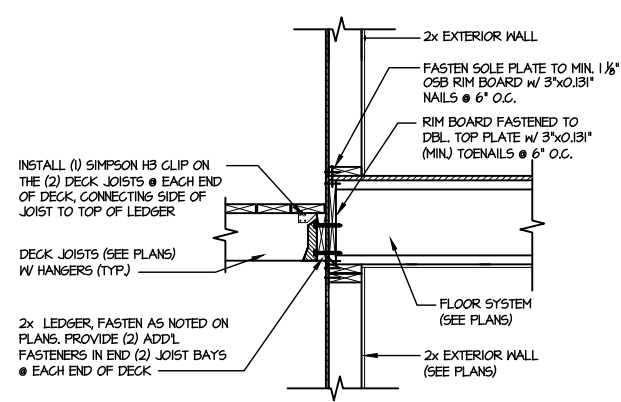

7 DECK CONNECTION DETAIL
SCALE: 3/4\"/>

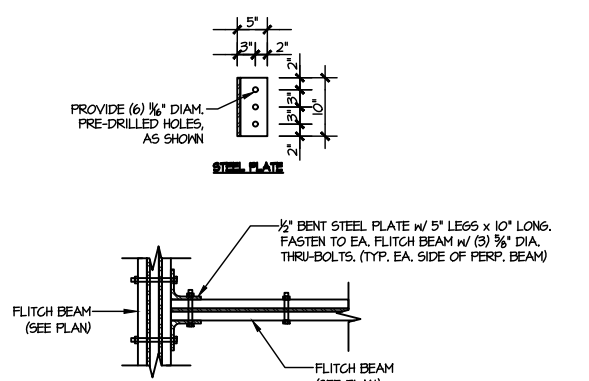

8 TYPICAL FLITCH BEAM TO FLITCH BEAM CONNECTION DETAIL
SCALE: 3/4\"/>

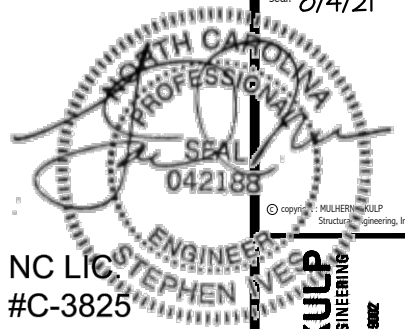

MULHERN+KULP
RESIDENTIAL STRUCTURAL ENGINEERING
300 Duneside Ave, Building 4 - Ambler, PA 19002
p: 215-998-8881 • mulhernkulp.com

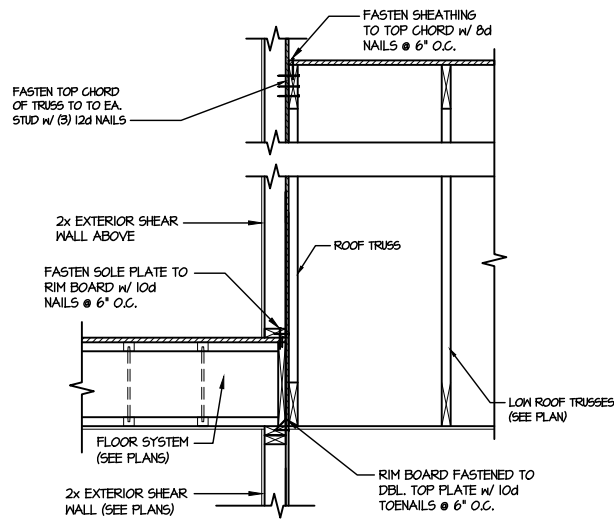

1 TYPICAL SHEAR TRANSFER DETAIL BETWEEN FLOORS @ INTERIOR WALL
SCALE: 3/4\"/>

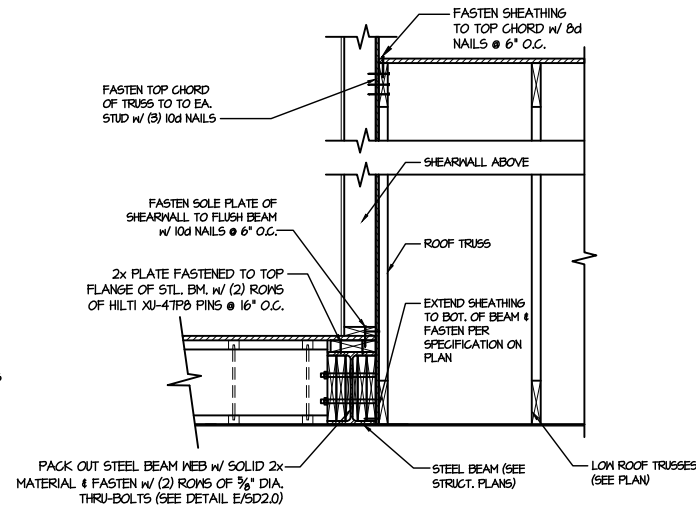

2 SHEAR TRANSFER DETAIL @ EXTERIOR SHEARWALL ABOVE
SCALE: 3/4\"/>

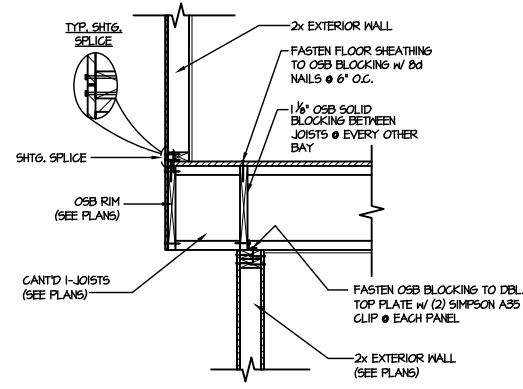

3 SHEAR TRANSFER DETAIL BETWEEN FLOORS @ CANT'D EXT. WALL
SCALE: 3/4\"/>

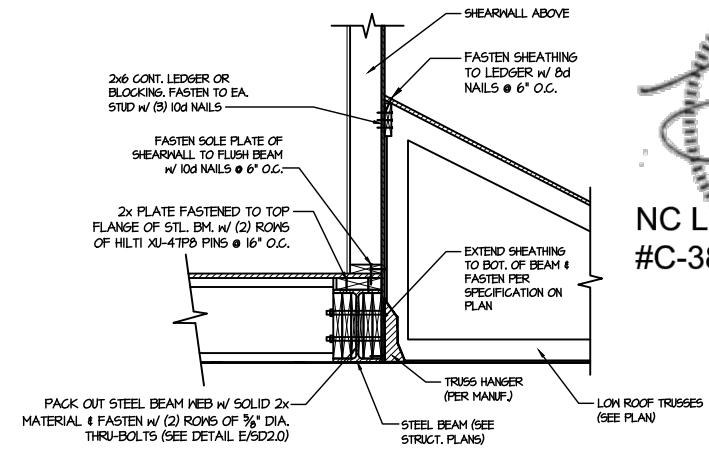

4 SHEAR TRANSFER DETAIL @ EXTERIOR SHEARWALL ABOVE
SCALE: 3/4\"/>

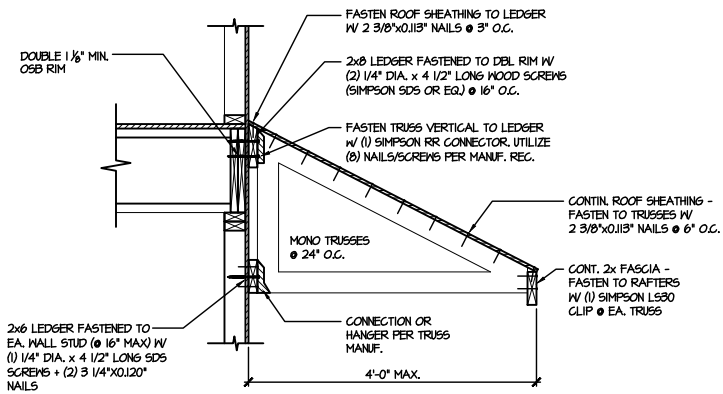

5 DETAIL @ SHED ROOF
SCALE: 3/8\"/>

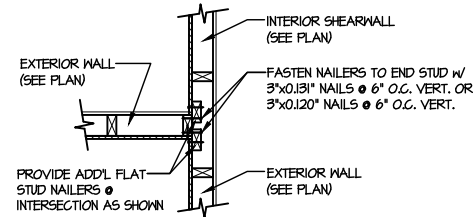

6 SHEAR TRANSFER DETAIL @ INTERSECTING INT. SHEARWALL
SCALE: 3/4\"/>

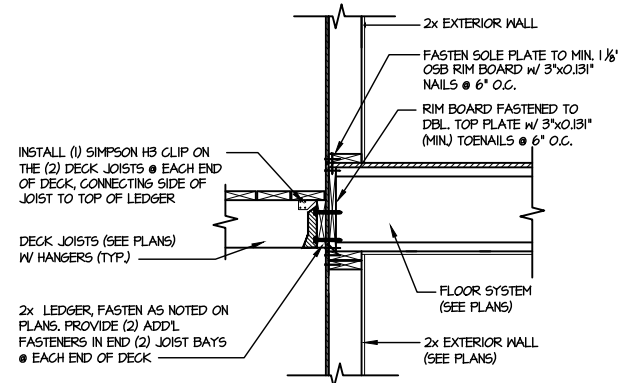

7 DECK CONNECTION DETAIL
SCALE: 3/4\"/>

M&K project number: 126-21019
project mgr: JTR
drawn by: KL
issue date: 07-16-21

REVISIONS:
date: initial:



FRAMING DETAILS
ELMHURST
RALEIGH, NC

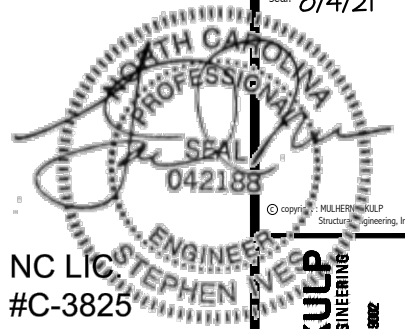

MULHERN+KULP
RESIDENTIAL STRUCTURAL ENGINEERING
300 Dismalville Ave, Building 4 - Anahier, PA 15002
p.715.548.8001 m.mulhern@mkp.com



M&K project number:
126-21019

project mgr: JTR
drawn by: KL
issue date: 07-16-21

REVISIONS:

date: initial:



FRAMING DETAILS
ELMHURST
RALEIGH, NC

sheet:

SD2.0T

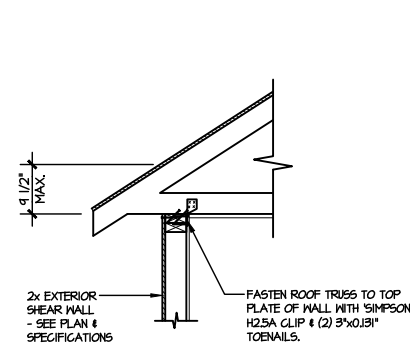

A1 TYPICAL SHEAR TRANSFER DETAIL @ ROOF
SCALE: 3/8"=1'-0"
HEEL HEIGHT LESS THAN 4 1/2"
NO BLOCKING REQ'D

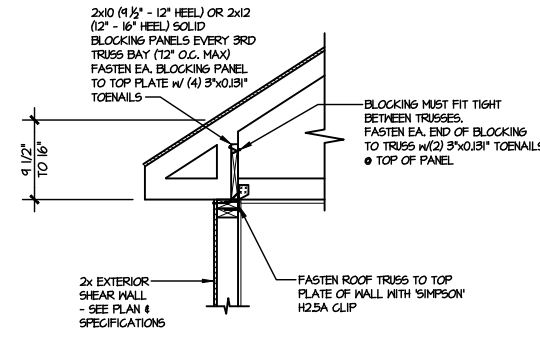

A2 TYPICAL SHEAR TRANSFER DETAIL @ ROOF
SCALE: 3/8"=1'-0"
HEEL HEIGHT BETWEEN 4 1/2" - 16"
BLOCKING REQ'D

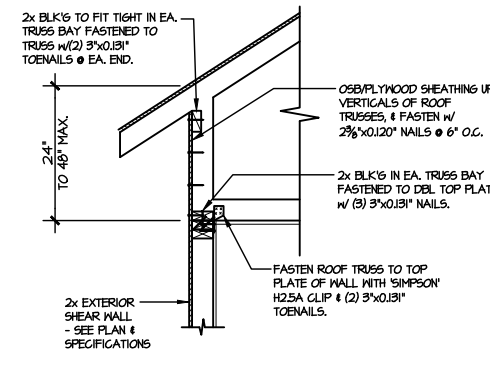

A3 TYPICAL SHEAR TRANSFER DETAIL @ RAISED HEEL TRUSS
SCALE: 3/8"=1'-0"
HEEL HEIGHT UP TO 48" MAX

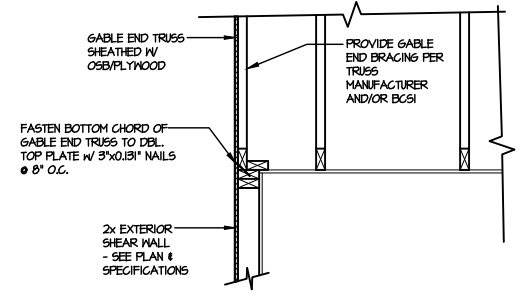

B TYPICAL GABLE END DETAIL
SCALE: 3/8"=1'-0"

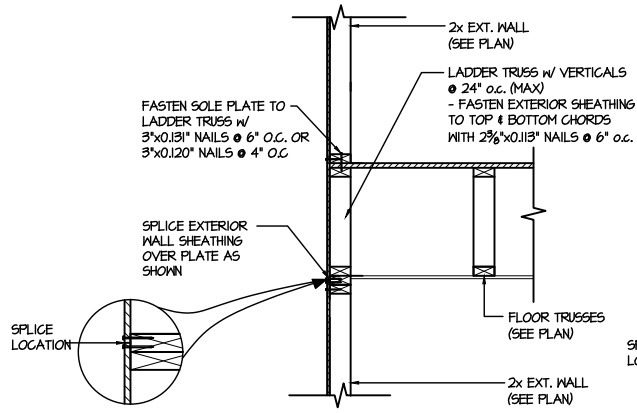

C1 TYPICAL SHEAR TRANSFER DETAIL BETWEEN FLOORS @ EXTERIOR WALL
SCALE: 3/8"=1'-0"
PARALLEL FRM

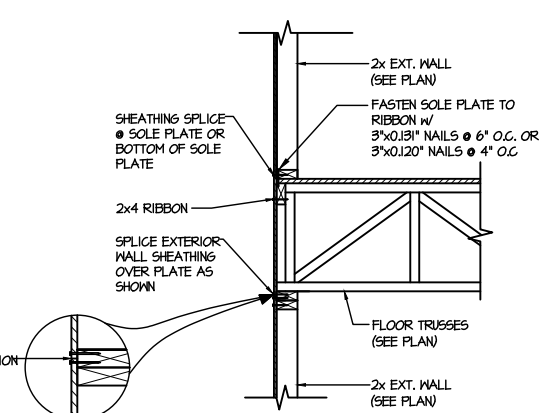

C2 TYPICAL SHEAR TRANSFER DETAIL BETWEEN FLOORS @ EXTERIOR WALL
SCALE: 3/8"=1'-0"
PERPENDICULAR FRM

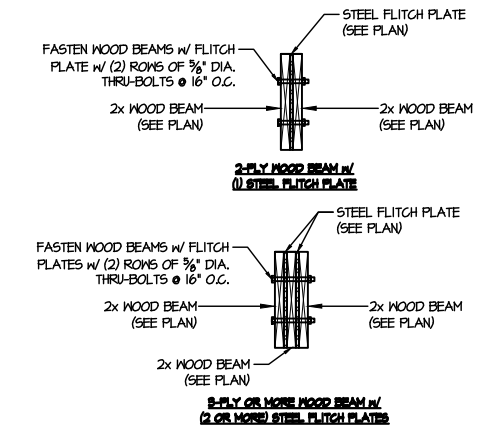

D TYPICAL FLITCH BEAM CONNECTION DETAIL
SCALE: 3/4"=1'-0"

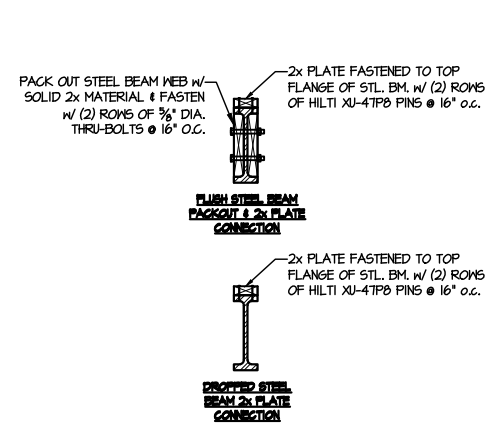

E TYPICAL STEEL BEAM CONNECTION DETAIL
SCALE: 3/4"=1'-0"

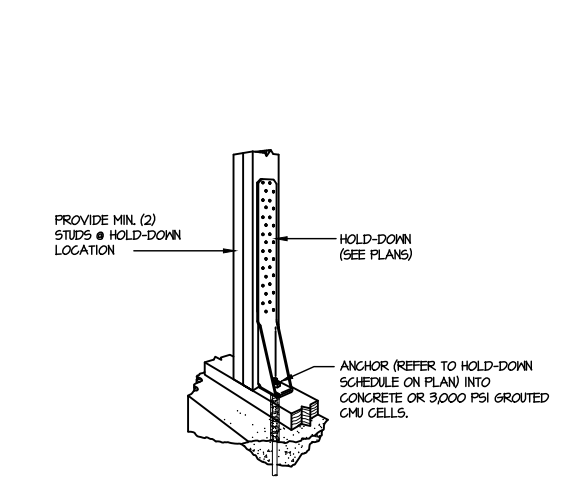

F1 TYPICAL HOLD DOWN INSTALLATION
SCALE: N.T.S.

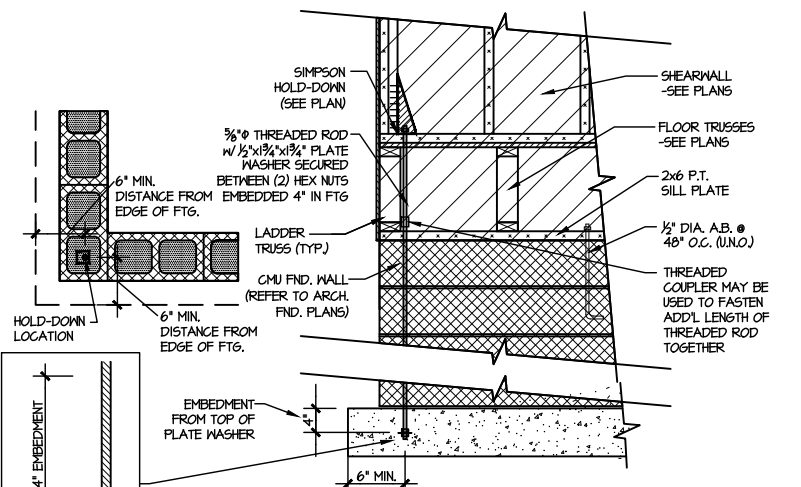

F2 TYPICAL CMU FOUNDATION HOLD-DOWN INSTALLATION
SCALE: N.T.S.
(CORNER SHOWN - APPLICABLE TO ALL CONDITIONS)

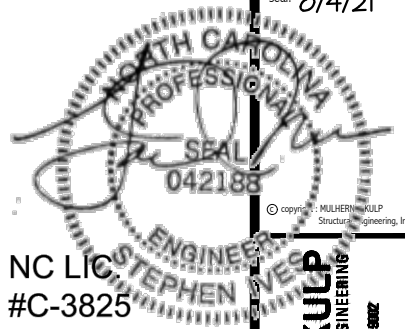

NC LIC #C-3825

MULHERN+KULP
RESIDENTIAL STRUCTURAL ENGINEERING
300 Dunsmuir Ave., Building 4 - Ambler, PA 19002
p: 215-998-8881 • mulhernkulp.com



M&K project number:
126-21019

project mgr: JTR
drawn by: KL
issue date: 07-16-21

REVISIONS:
date: initial:



FRAMING DETAILS
ELMHURST
RALEIGH, NC

sheet:
SD2.1AT

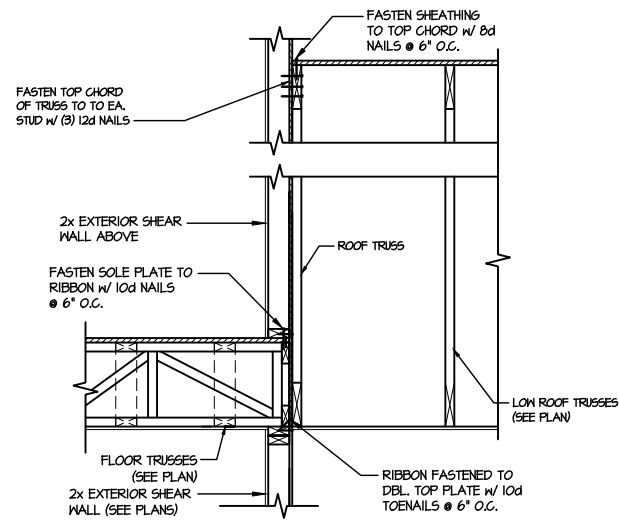

1 TYPICAL SHEAR TRANSFER DETAIL BETWEEN FLOORS @ INTERIOR WALL
SCALE: 3/4"=1'-0"

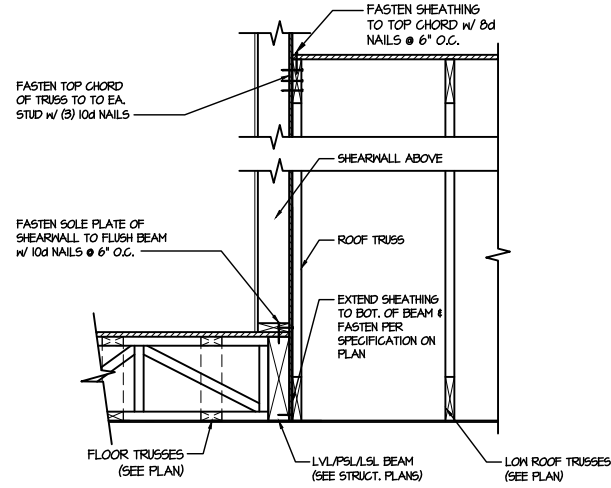

2 SHEAR TRANSFER DETAIL @ EXTERIOR SHEARWALL ABOVE
SCALE: 3/4"=1'-0"

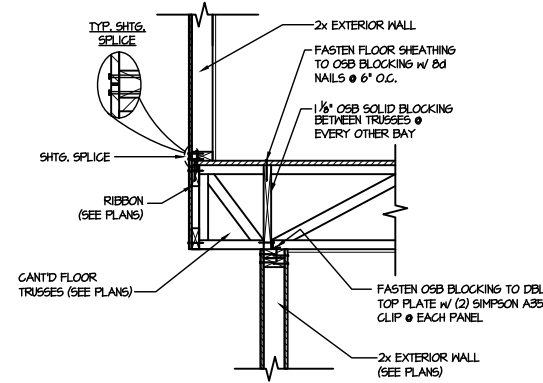

3 SHEAR TRANSFER DETAIL BETWEEN FLOORS @ CANT'D EXT. WALL
SCALE: 3/4"=1'-0" PERPENDICULAR FRAMING

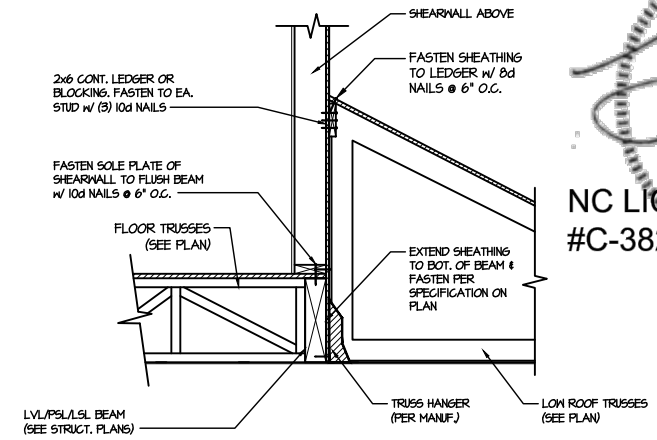

4 SHEAR TRANSFER DETAIL @ EXTERIOR SHEARWALL ABOVE
SCALE: 3/4"=1'-0"

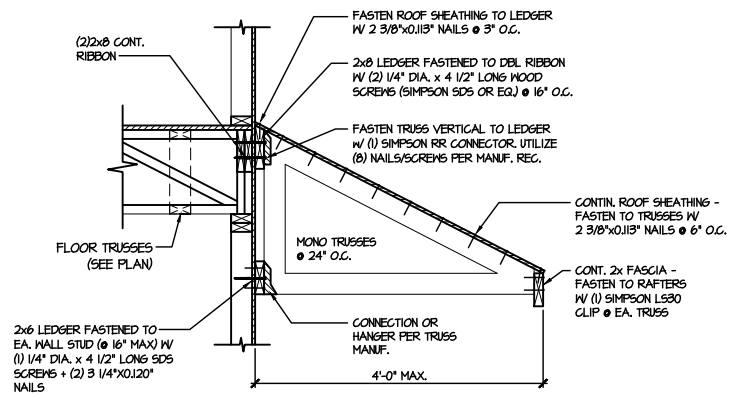

5 DETAIL @ SHED ROOF
SCALE: 3/8"=1'-0"

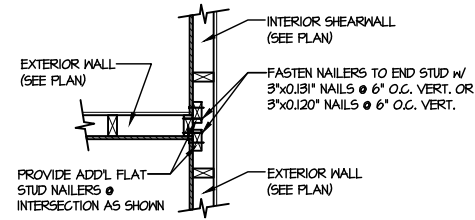

6 SHEAR TRANSFER DETAIL @ INTERSECTING INT. SHEARWALL
SCALE: 3/4"=1'-0" SHTS. ON SAME FACE

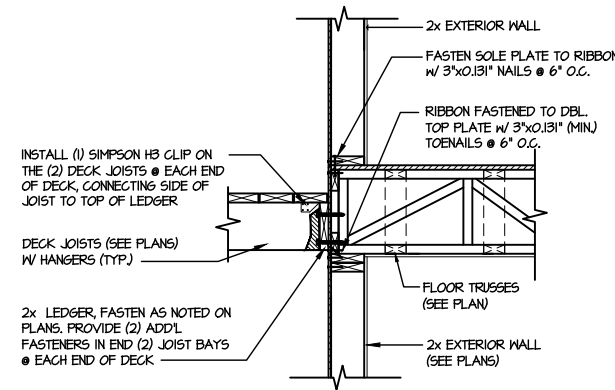

7 DECK CONNECTION DETAIL
SCALE: 3/4"=1'-0"

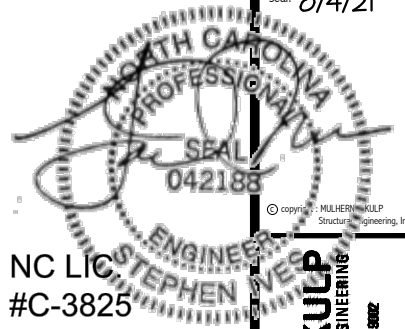

MULHERN+KULP
RESIDENTIAL STRUCTURAL ENGINEERING
300 Rembrandt Ave. Building 4 - Asheville, PA 18002
P: 717-648-8801 • mulhern@mkp.com



M&K project number:
126-21019
project mgr: JTR
drawn by: KL
issue date: 07-16-21
REVISIONS:
date: initial:



FRAMING DETAILS
ELMHURST
RALEIGH, NC

sheet:
SD2.1BT

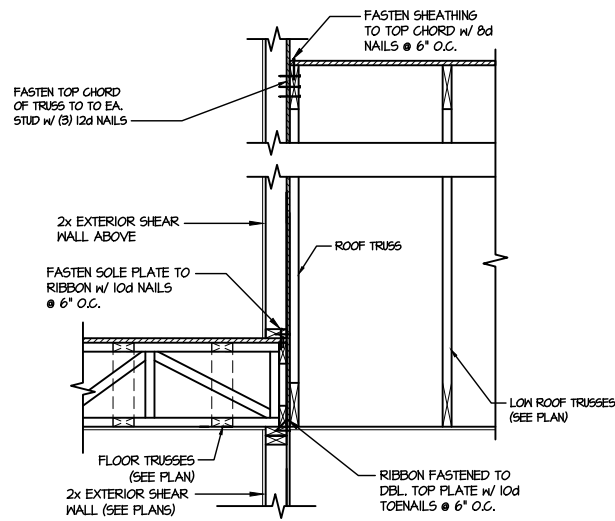

1 TYPICAL SHEAR TRANSFER DETAIL BETWEEN FLOORS @ INTERIOR WALL
SCALE: 3/4\"/>

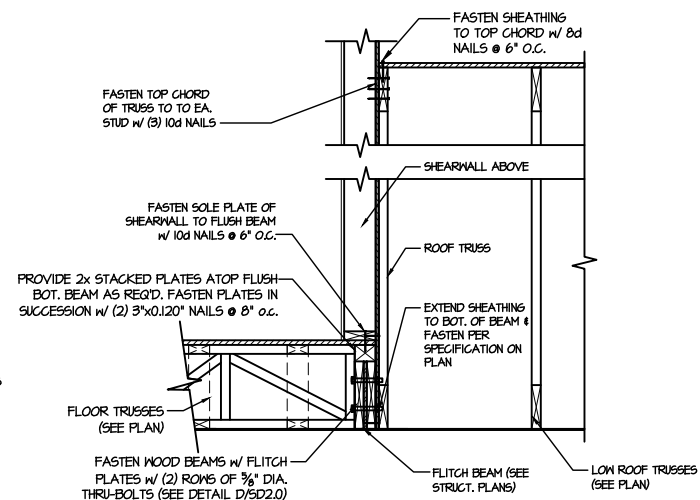

2 SHEAR TRANSFER DETAIL @ EXTERIOR SHEARWALL ABOVE
SCALE: 3/4\"/>

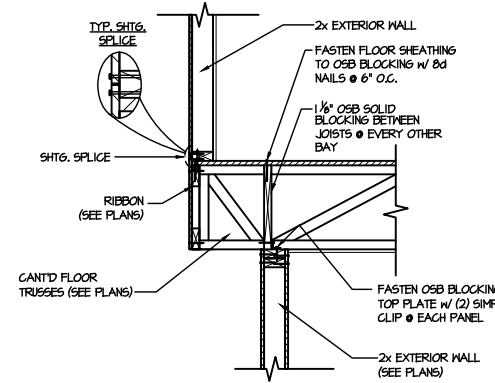

3 SHEAR TRANSFER DETAIL BETWEEN FLOORS @ CANT'D EXT. WALL PERPENDICULAR FRAMING
SCALE: 3/4\"/>

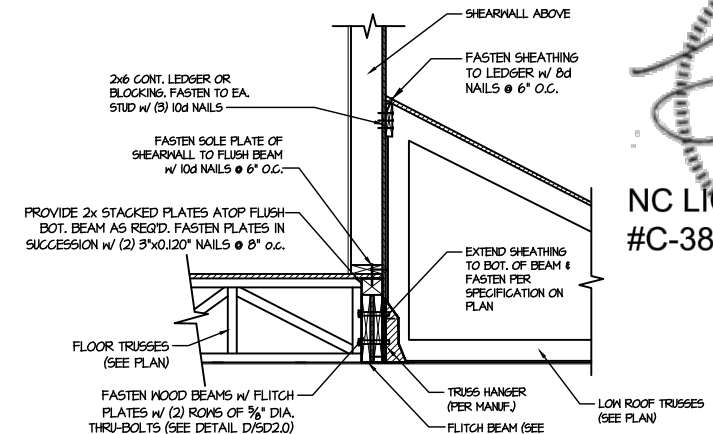

4 SHEAR TRANSFER DETAIL @ EXTERIOR SHEARWALL ABOVE
SCALE: 3/4\"/>

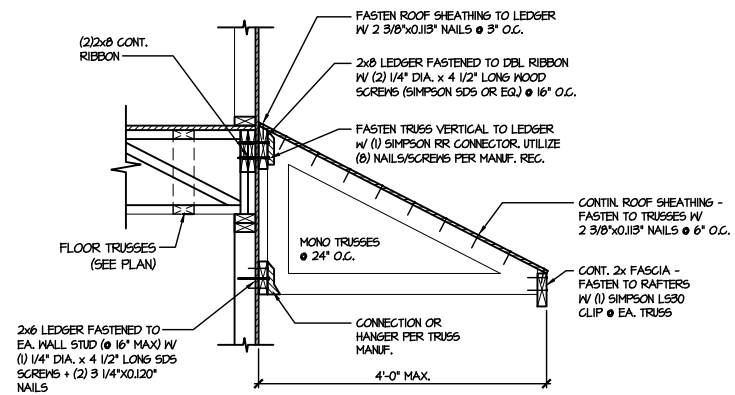

5 DETAIL @ SHED ROOF
SCALE: 3/8\"/>

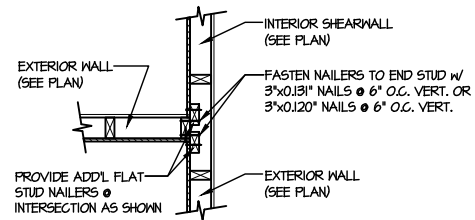

6 SHEAR TRANSFER DETAIL @ INTERSECTING INT. SHEARWALL
SCALE: 3/4\"/>

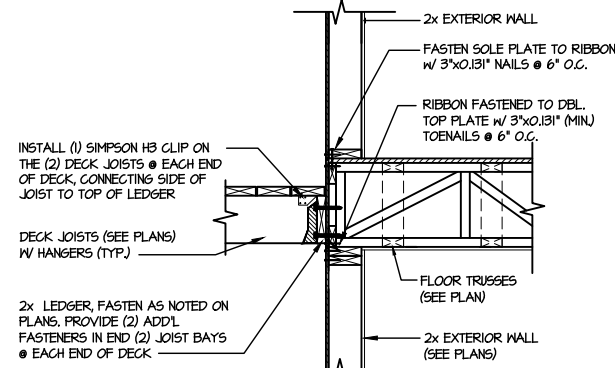

7 DECK CONNECTION DETAIL
SCALE: 3/4\"/>

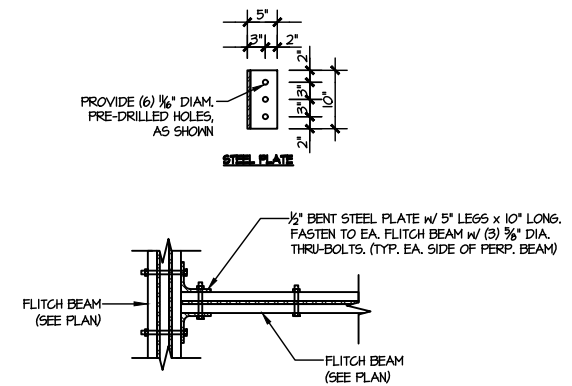

8 TYPICAL FLITCH BEAM TO FLITCH BEAM CONNECTION DETAIL
SCALE: 3/4\"/>

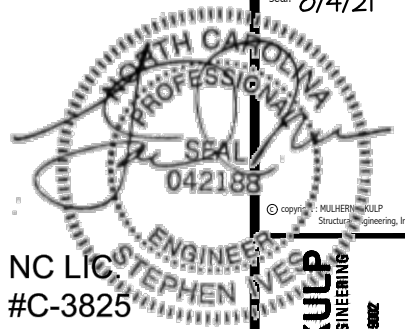

NC LIC #C-3825

MULHERN+KULP
RESIDENTIAL STRUCTURAL ENGINEERING
300 Duneside Ave, Building 4 - Annapolis, PA 19802
P: 715-948-8881 • mulhern+kulp.com



M&K project number:
126-21019

project mgr: JTR
drawn by: KL
issue date: 07-16-21

REVISIONS:
date: initial:



FRAMING DETAILS
ELMHURST
RALEIGH, NC

sheet:
SD2.1CT

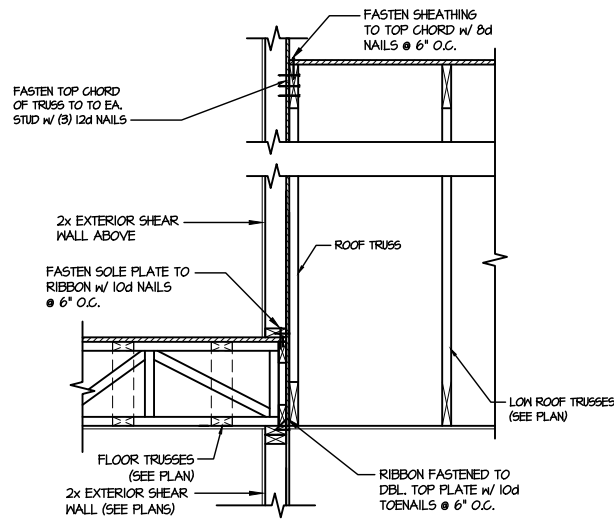

1 TYPICAL SHEAR TRANSFER DETAIL BETWEEN FLOORS @ INTERIOR WALL
SCALE: 3/4\"/>

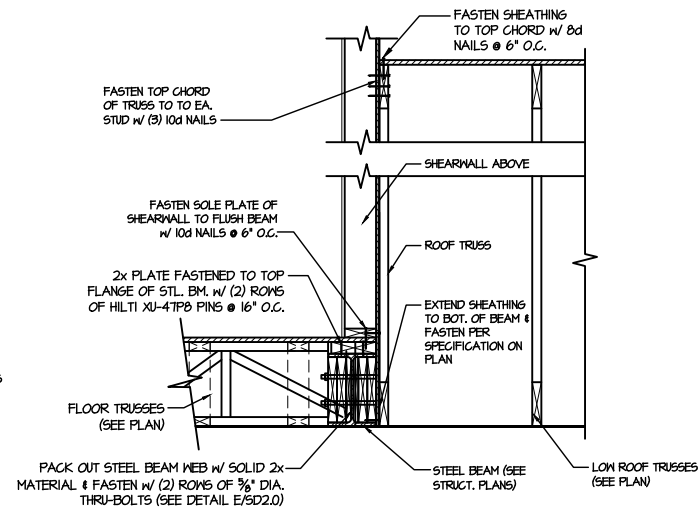

2 SHEAR TRANSFER DETAIL @ EXTERIOR SHEARWALL ABOVE
SCALE: 3/4\"/>

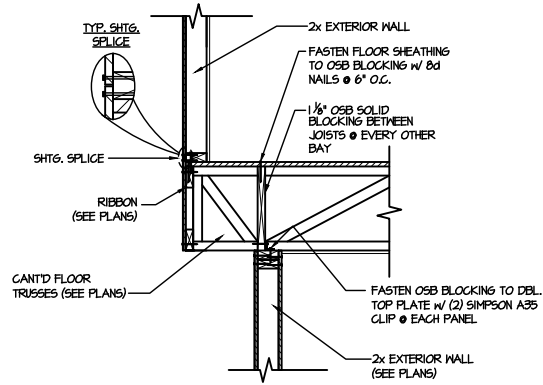

3 SHEAR TRANSFER DETAIL BETWEEN FLOORS @ CANT'D EXT. WALL
SCALE: 3/4\"/>

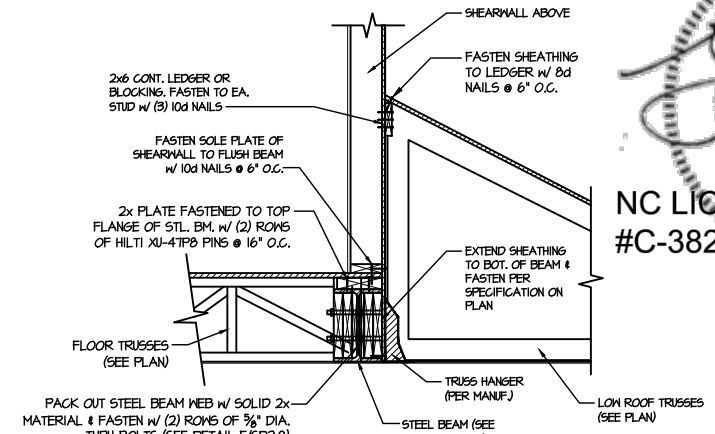

4 SHEAR TRANSFER DETAIL @ EXTERIOR SHEARWALL ABOVE
SCALE: 3/4\"/>

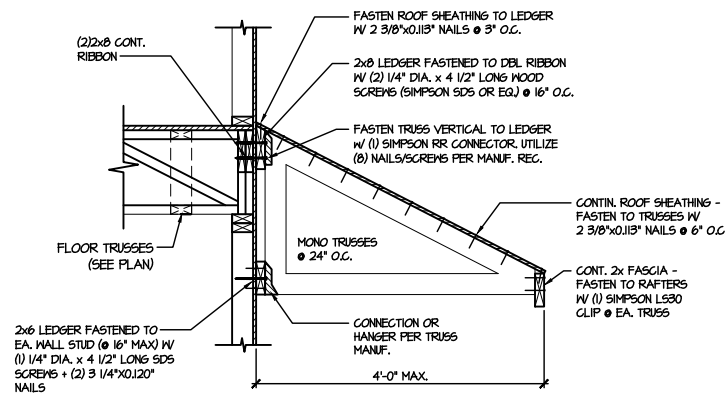

5 DETAIL @ SHED ROOF
SCALE: 3/8\"/>

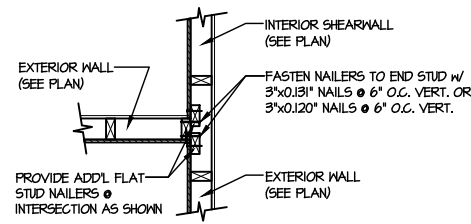

6 SHEAR TRANSFER DETAIL @ INTERSECTING INT. SHEARWALL
SCALE: 3/4\"/>

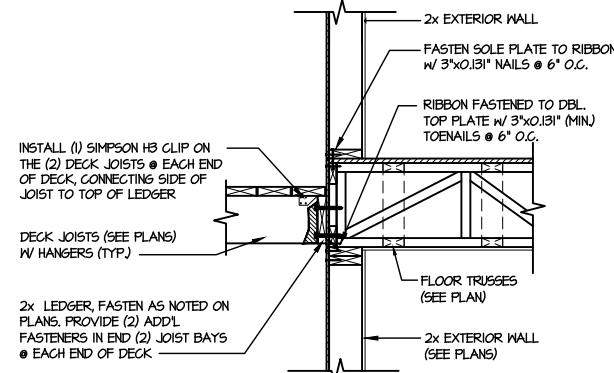

7 DECK CONNECTION DETAIL
SCALE: 3/4\"/>

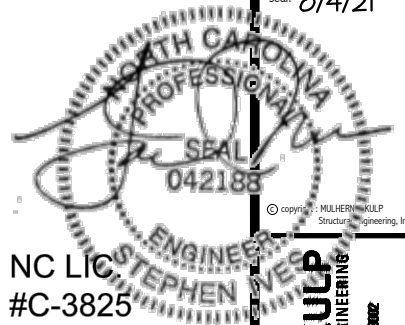

NC LICENSE #C-3825

MULHERN+KULP
RESIDENTIAL STRUCTURAL ENGINEERING
300 Darnside Ave. Building 4 - Asheville, PA 18002
P: 715-648-8801 - mulhern@mkp.com



MXK project number:

126-21019

project mgr:

JTR

drawn by:

KL

issue date:

07-16-21

REVISIONS:

date: initial:

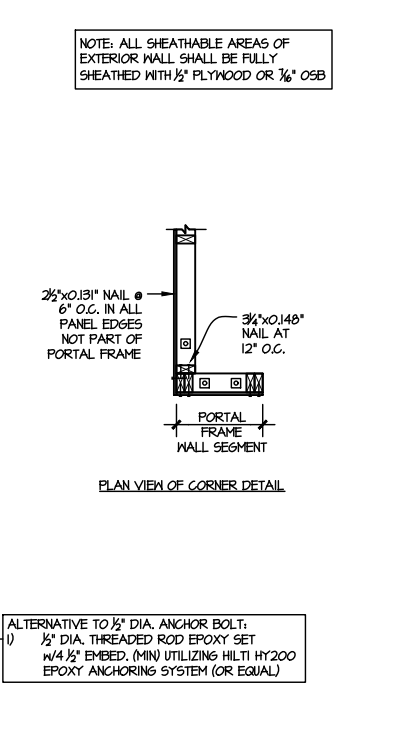
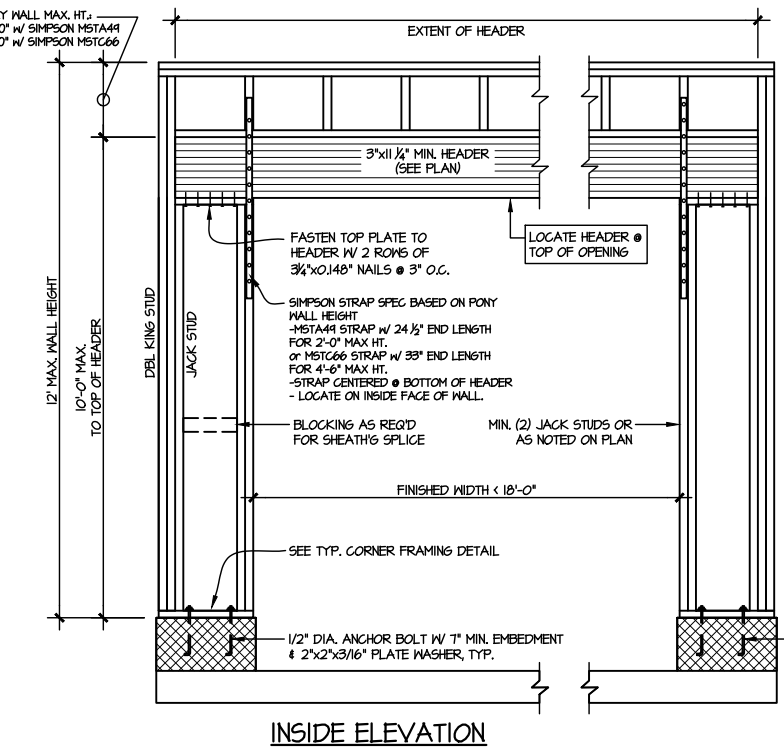
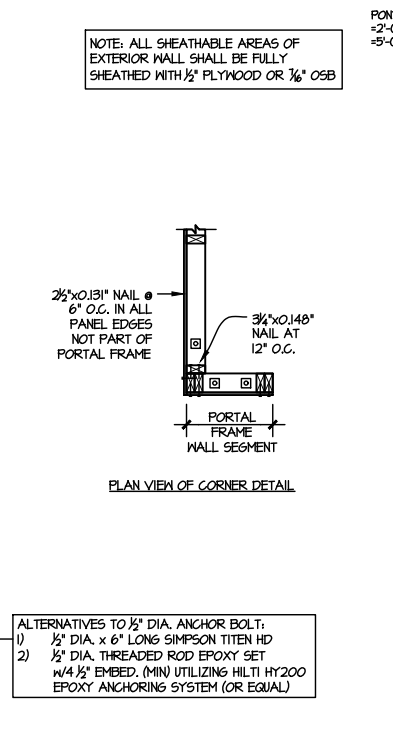
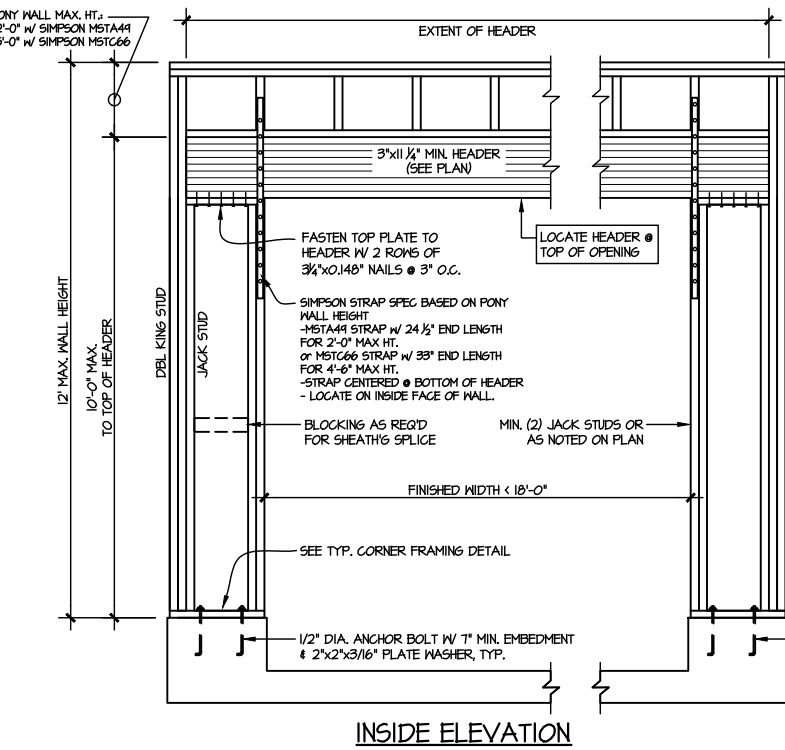
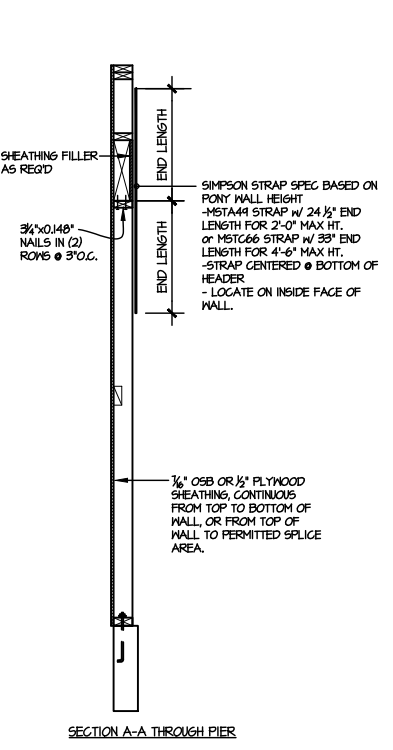
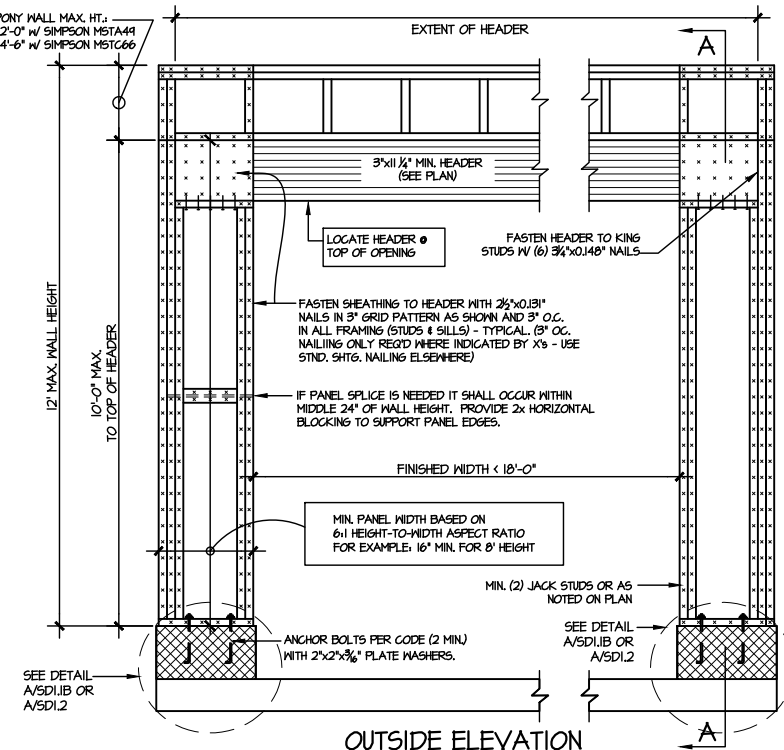
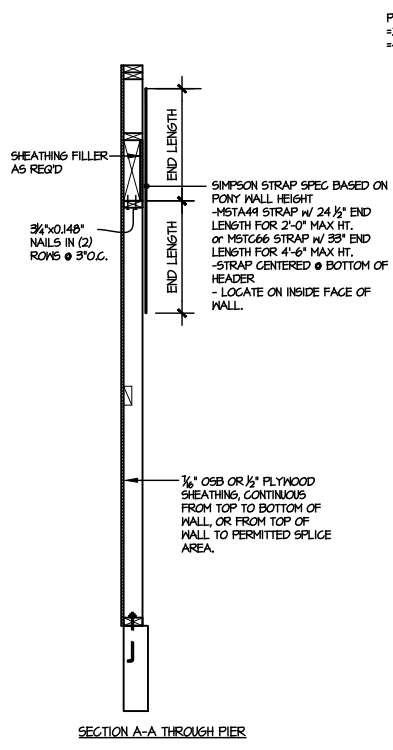
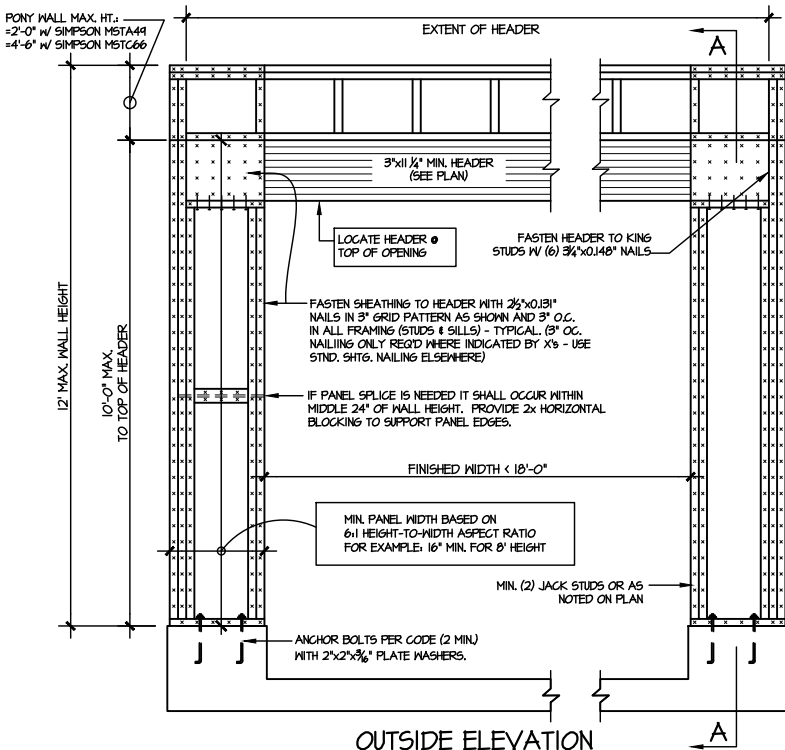

TWO SIDED GARAGE PORTAL FRAME BRACING ELEVATION ON CONCRETE STEM
SCALE: N.T.S.

TWO SIDED GARAGE PORTAL FRAME BRACING ELEVATION ON CMU STEM
SCALE: N.T.S.

ALTERNATIVES TO 1/2" DIA. ANCHOR BOLT:
1) 1/2" DIA. x 6" LONG SIMPSON TITEN HD
2) 1/2" DIA. THREADED ROD EPOXY SET w/4 1/2" EMBED. (MIN UTILIZING HILTI HY200 EPOXY ANCHORING SYSTEM (OR EQUAL))

NOTE: ALL SHEATHABLE AREAS OF EXTERIOR WALL SHALL BE FULLY SHEATHED WITH 1/2" PLYWOOD OR 3/8" OSB

NOTE: ALL SHEATHABLE AREAS OF EXTERIOR WALL SHALL BE FULLY SHEATHED WITH 1/2" PLYWOOD OR 3/8" OSB

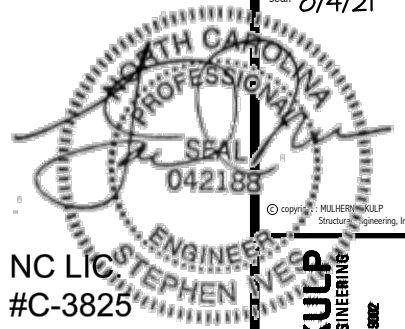

NC LIC #C-3825

MULHERN+KULP
RESIDENTIAL STRUCTURAL ENGINEERING
300 Dunsmuir Ave, Building 4 - Amber, PA 15002
P: 715-548-8001 • mulhern+kulp.com



M&K project number: 126-21019
project mgr: JTR
drawn by: KL
issue date: 07-16-21

REVISIONS:
date: initial:

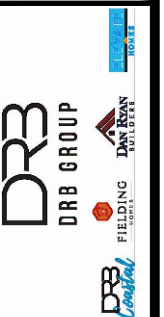

FRAMING DETAILS
ELMHURST
RALEIGH, NC

sheet: SD3.0

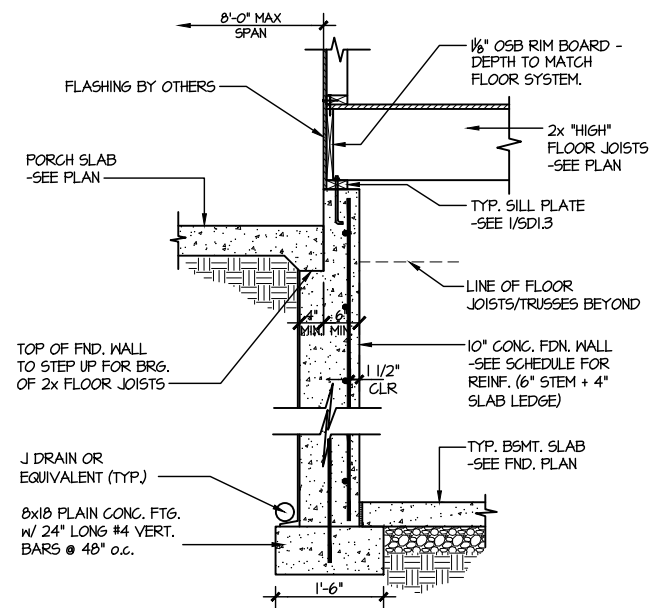
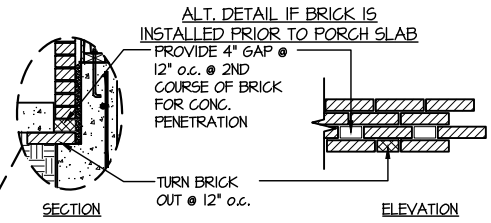

4 HIGH FLOOR JOIST BASEMENT FOUNDATION @ PORCH/PATIO SLAB
SCALE: 3/8"=1'-0"
(REFER TO DETAIL 12 FOR WOOD PORCH OPTION)

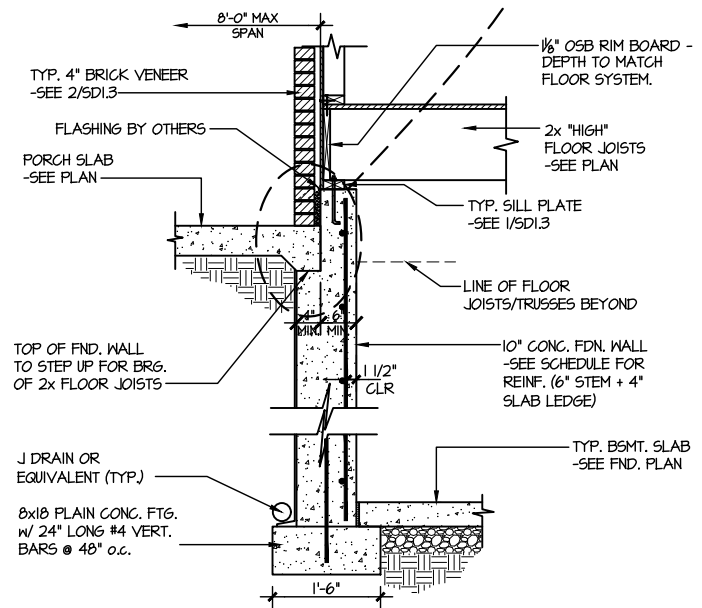

5 HIGH FLOOR JOIST BASEMENT FOUNDATION @ PORCH/PATIO SLAB
SCALE: 3/8"=1'-0"
w/ BRICK VENEER
(REFER TO DETAIL 12 FOR WOOD PORCH OPTION)

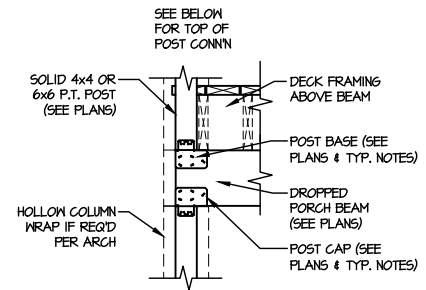

TYPICAL CONNECTION
DETAIL @ 2nd FLOOR DECK

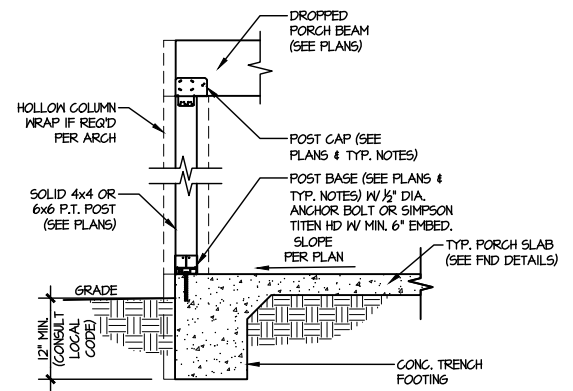

3 TYPICAL PORCH POST CONNECTION DETAIL
SCALE: NONE
SLAB ON GRADE SHOWN (SIM. @ CRAWL & BSMT.)

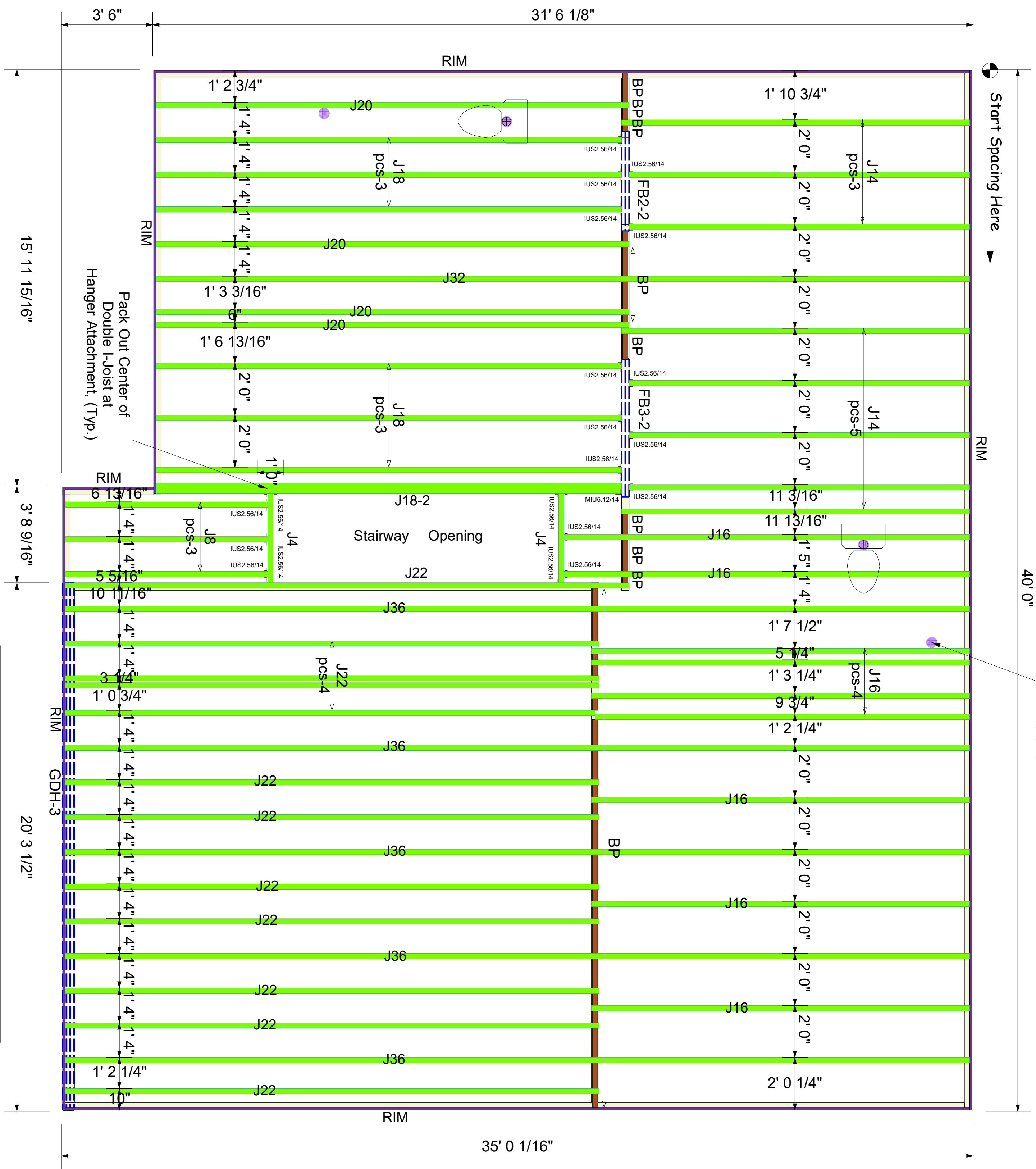
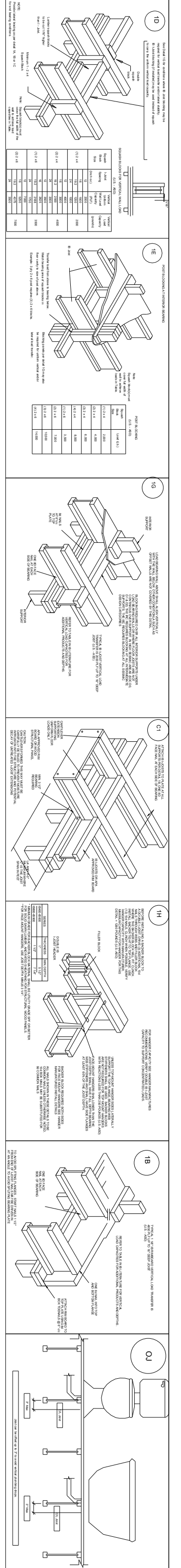

Connector Summary		
Qty	Manuf	Product
20	Simpson	IUS2.56/14
1	Simpson	MIU5.12/14

PlotID	Length	Product	Piles	Net Qty	Fab Type
J36	36' 0"	14" PJI-40	1	5	MFD
J32	32' 0"	14" PJI-40	1	1	MFD
J22	22' 0"	14" PJI-40	1	12	MFD
J20	20' 0"	14" PJI-40	1	4	MFD
J18	18' 0"	14" PJI-40	1	6	MFD
J18-2	18' 0"	14" PJI-40	2	2	MFD
J16	16' 0"	14" PJI-40	1	9	MFD
J14	14' 0"	14" PJI-40	1	8	MFD
J4	4' 0"	14" PJI-40	1	3	MFD
J4	4' 0"	14" PJI-40	1	2	MFD
FB3-2	6' 0"	2.0 RigidLam DF LVL 1-3/4 x 14	2	2	FF
FB2-2	4' 0"	2.0 RigidLam DF LVL 1-3/4 x 14	2	2	FF
GDH-3	22' 0"	2.0 RigidLam DF LVL 1-3/4 x 16	3	3	FF
RIM	12' 0"	1 1/8" x 14" APA Rim Board	1	13	FF
BP	2' 0"	14" PJI-40	1	12	FF

BLOCK SOLID UNDER ALL POST /POINT LOADS FROM ABOVE - TYPICAL AT ALL LOCATIONS

2nd Floor I-Joist DRAWING SCALE : NTS

PROJECT NUMBER	22060076
SHEET NUMBER	1 / 1
REVISIONS	DATE BY
	06.27.21 RKW

DRB Homes NC LLC
123 Farm at Neills Creek (Elmhurst 1-GRFE)
2nd FLOOR I-JOIST PLACEMENT PLAN



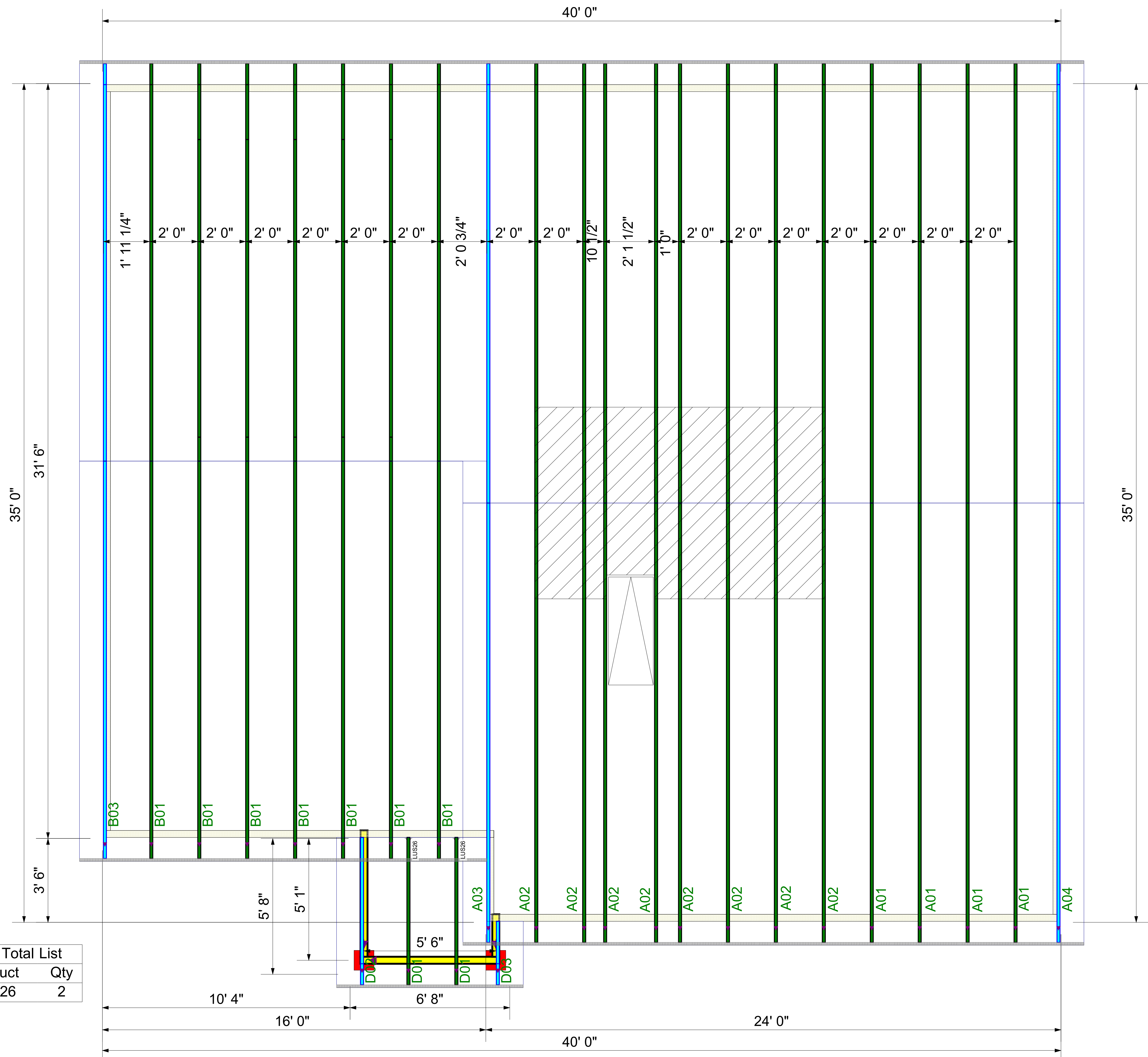

Truss Connector Total List		
Manuf	Product	Qty
Simpson	LUS26	2

ROOF TRUSS FRAMING

DRAWING SCALE : NTS



DRB GROUP
123 FARM AT NEILLS CREEK - ELMHURST 1
ROOF TRUSS PLACEMENT PLAN

REVISIONS	
DATE	BY
6-24-22	ND

PROJECT NUMBER
22060076
 SHEET NUMBER
1 / 1