



SOUTHPORT

Inventory Marked
lot 15 Williams Farm

COVER SHEET

H&H HOMES
SOUTHPORT

SOUTHPORT REVISION LIST - STRUCTURAL:

1. COMBINED WILMINGTON AND WILMINGTON II PLANS. (2-18)
2. ADDED BRICK OPTION ON SECOND FLOOR. (2-18)
3. CALLED OUT SERIES/SPACING OF JOISTS ON BASEMENT. (2-18)
4. 2018 NCRC UPDATE (6-19)
5. 2018 SC IRC (2-15-20)
6. ADDED ELEVATION A.2 (BRICK WATERTABLE W/ SIDING ABOVE) & ELEVATION A.3 (STONE WATERTABLE W/ SIDING ABOVE). (2-15-20)

SOUTHPORT REVISION LIST - ARCHITECTURAL:

AUGUST 01, 2021

1. CREATED ELEVATIONS TO BE IN STANDARDS WITH OTHER PLANS (SEE SHEETS A-1 THROUGH A-3.5)
2. CHANGED COLUMNS ON ELEVATIONS TO STANDARD COLUMNS
3. CHANGED GARAGE DOORS TO REPRESENT STANDARD GARAGE DOOR FOR EACH ELEVATION
4. FIXED COVERED PORCH TO KEEP COLUMNS FROM OVERLAPPING EDGE OF CONCRETE
5. REMOVED GRIDS FROM TRANSOMS ABOVE FRONT DOOR
6. ADDED NOTE FOR GARAGE DOOR "GARAGE DOOR PER SPECIFICATIONS AND GLASS INSERT (TOP PANEL ONLY)"
7. MOVED ROOF PLANS TO SHEETS A-8 & A-8.1
8. CREATED SLAB INTERFACE PLAN (SEE SHEET A-4 THROUGH A-4.2)
9. MOVED ALL OPTIONS OFF BASE PLAN AND PLACED ON SEPARATE SHEET
10. ADDED NOTE FOR FLUSH COUNTERTOP ON ISLAND
11. CHANGED PATIO SIZE TO STANDARD 12'X10'
12. ADDED OPTIONAL GAS LINE
13. CHANGED KITCHEN LAYOUT
14. ADDED 2ND HOSE BIB
15. CALLED OUT "45" WALL WITH CAP" AS STANDARD
16. CHANGED ALL EXTERIOR WALLS FROM 2X6 TO 2X4 EXCEPT WHERE SHADED
17. ADDED NOTE "OPT. REF."
18. REMOVED NUMBERS ON STAIRS
19. ADDED NOTE "OPT. W/D"
20. ADDED NOTE "WASHER ALWAYS TO BE LOCATED TO THE LEFT OF DRYER"
21. VERIFIED VENTILATION AND LIGHT REQUIREMENTS AT OWNER'S BEDROOM MEETS CODE (11-01-20)
22. SQUARE FOOTAGES ARE UPDATED AND CHANGED DUE TO MOVEMENT OF WALLS FROM 2X6 TO 2X, TO KEEP JOGS IN ROOMS, EXTERIOR WALL MOVED MEANING ROOF LINES HAVE CHANGED
23. SQUARE FOOTAGE OF COVERED PORCH CHANGED DUE TO KEEPING COLUMNS FROM OVERLAPPING CONCRETE EDGE
24. CREATED PARTIAL PLANS FOR B & C ELEVATIONS (FLOOR, SLAB, & ELECTRICAL)
25. REMOVED ALL WALL OUTLETS
26. REMOVED ALL PHONE OUTLETS
27. REMOVED ALL TV OUTLETS
28. PLACED STANDARD 3 BULB LIGHT IN KITCHEN
29. VERIFIED COACH LIGHT LOCATIONS (SEE ELEVS. FOR DIMS.)
30. PLACED DASHED FANS WHERE APPLICABLE WITH NOTE "STD. LIGHT, OPT. FAN/LT PREWIRE"
31. UPDATED ELECTRICAL KEY
32. VERIFIED CO2 DETECTOR LOCATIONS
33. SHOWED PENDANT LIGHTS AS OPTIONAL
34. SHOWED CAN LIGHTS IN KITCHEN AND FAMILY ROOM AS "OPTIONAL CAN LIGHTS"
35. PLACED OPTIONAL FLOOD LIGHTS
36. PLACED OPTIONAL FLOOR OUTLET IN FAMILY ROOM
37. PLACED CALCULATIONS FOR SOFFIT AND RIDGE VENT REQUIREMENTS
38. UPDATED STAIR LAYOUT TO KEEP MAIN WALL AT KITCHEN FROM MOVING WHEN OPTIONAL BASEMENT SELECTED.

DATE: SEPTEMBER 16, 2019
 REV.: AUGUST 01, 2021
 DRAWN BY:
 ENGINEERED BY:
 REVIEWED BY:

CS



Front Elevation-A-2

w/ ~~Brick~~ stone

SCALE: 1/4"=1'-0" ON 22x34
1/8"=1'-0" ON 11x17



Front Elevation

W/ Opt 2-Car & Opt 3-Car side load Garage
SCALE: 1/4"=1'-0" ON 22x34 AND 1/8"=1'-0" ON 11x17

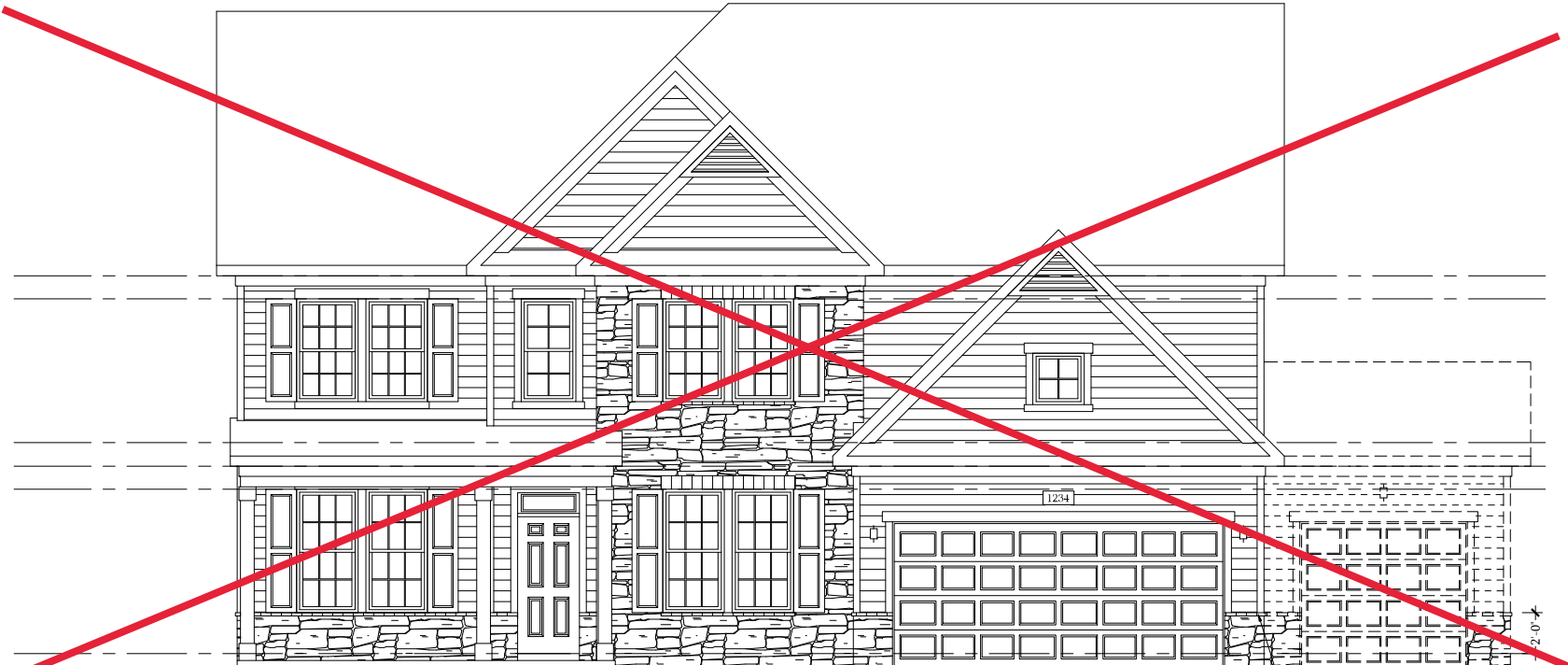

Front Elevation-A-3

w/ Brick

SCALE: 1/4"=1'-0" ON 22x34 AND 1/8"=1'-0" ON 11x17

COLONIAL RAISED
PAINEL WHITE



PRICES, PROMOTIONS, INCENTIVES, FEATURES, MATERIALS AND DIMENSIONS ARE SUBJECT TO CHANGE WITHOUT NOTICE. SOURCE FOOTAGE AND DIMENSIONS ARE ESTIMATED AND MAY VARY IN ACTUAL CONSTRUCTION. ACTUAL POSITION OF HOUSE ON LOT, WALL PLACEMENT, WINDOW PLACEMENT, FLOOR PLANS AND ELEVATION RENDERINGS ARE ARTIST'S CONCEPTIONS. FLOOR PLANS ARE THE COPYRIGHTED PROPERTY OF H&H HOMES. ANY USE, REPRODUCTION, ADAPTATION, OR DISPLAY OF THE PLANS IS STRICTLY PROHIBITED. REVIEW THESE SALES OFFERS FOR CURRENT DETAILS. COPYRIGHT © 2019 H&H HOMES

H&H HOMES, INC
SOUTHPORT

DATE: SEPTEMBER 16, 2019

REV.: AUGUST 01, 2021

SCALE: AS NOTED

DRAWN BY:

ENGINEERED BY:

REVIEWED BY:

A-2 & A-3
ELEVATION (W/
STONE FRONT)

A-1.3

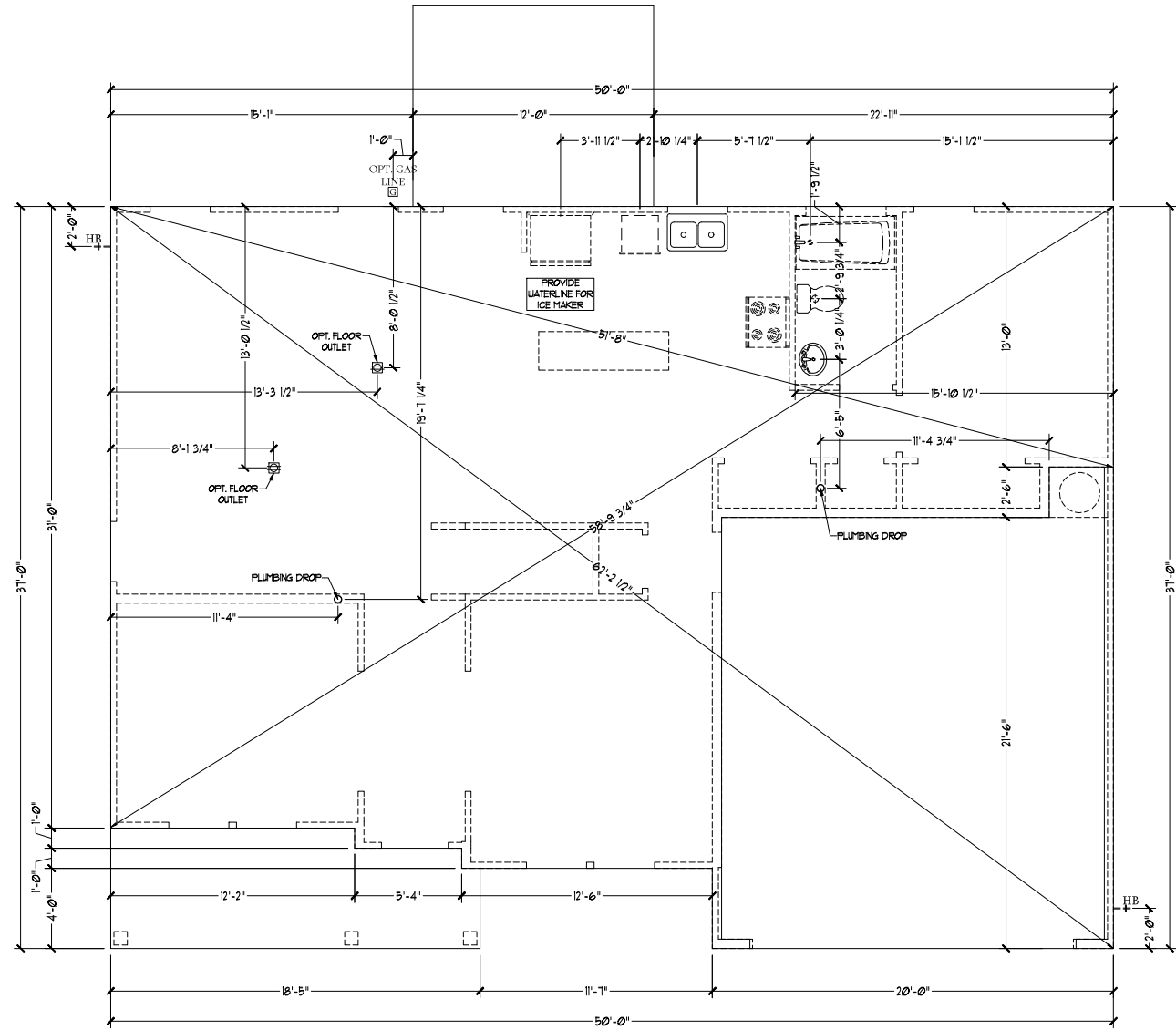

Slab Interface Plan
 SCALE: 1/4"=1'-0" ON 22x34 AND 1/8"=1'-0" ON 11x17



PRICES, PROMOTIONS, INCENTIVES, FEATURES, MATERIALS AND DIMENSIONS ARE SUBJECT TO CHANGE WITHOUT NOTICE. SOURCE FOOTAGE AND DIMENSIONS ARE ESTIMATED AND MAY VARY IN ACTUAL CONSTRUCTION. ACTUAL POSITION OF HOUSE ON LOT, WALL THICKNESS, WINDOW AND DOOR SIZES, FLOOR PLANS AND ELEVATION DIMENSIONS ARE LATEST CONCEPTIONS. FLOOR PLANS ARE THE COPYRIGHTED PROPERTY OF H&H HOMES. ANY USE, REPRODUCTION, ADAPTATION, OR DISPLAY OF THE PLANS IS STRICTLY PROHIBITED. REVIEW THESE PLANS CAREFULLY FOR CURRENT DETAILS. COPYRIGHT © 2019 H&H HOMES

H&H HOMES, INC
SOUTHPORT

DATE: SEPTEMBER 16, 2019
 REV.: AUGUST 01, 2021
 SCALE: 1/4"=1'-0"
 DRAWN BY:
 ENGINEERED BY:
 REVIEWED BY:

SLAB INTERFACE
 PLAN
A-4

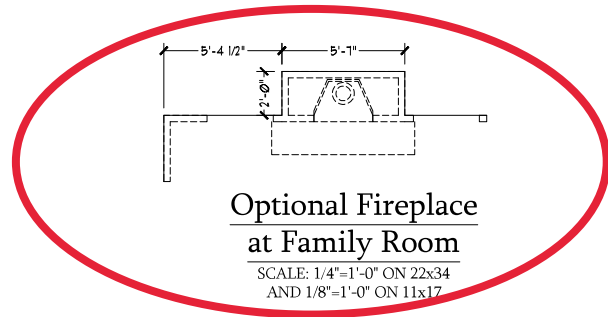

Optional Fireplace at Family Room

SCALE: 1/4"=1'-0" ON 22x34 AND 1/8"=1'-0" ON 11x17

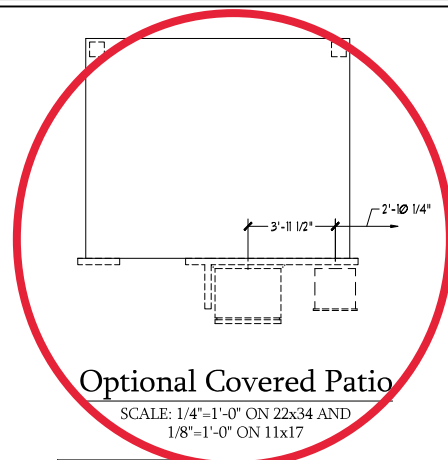

Optional Covered Patio

SCALE: 1/4"=1'-0" ON 22x34 AND 1/8"=1'-0" ON 11x17

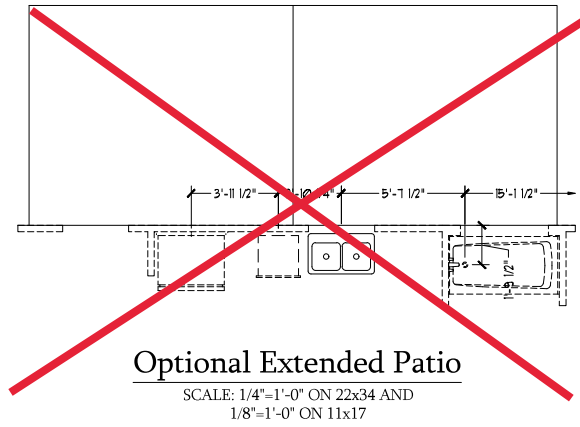

Optional Extended Patio

SCALE: 1/4"=1'-0" ON 22x34 AND 1/8"=1'-0" ON 11x17

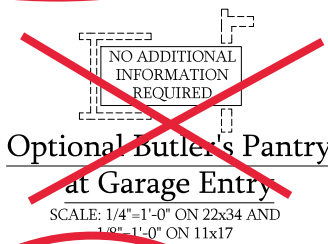

Optional Butler's Pantry at Garage Entry

SCALE: 1/4"=1'-0" ON 22x34 AND 1/8"=1'-0" ON 11x17



Optional Gourmet Kitchen

SCALE: 1/4"=1'-0" ON 22x34 AND 1/8"=1'-0" ON 11x17



Optional Desk at Kitchen

SCALE: 1/4"=1'-0" ON 22x34 AND 1/8"=1'-0" ON 11x17



Optional Open Rail LO 45" Wall w/ Cap

SCALE: 1/4"=1'-0" ON 22x34 AND 1/8"=1'-0" ON 11x17

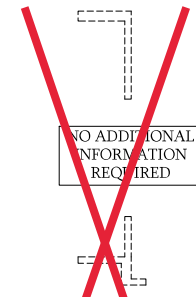

Optional Bi-Swing Doors at Study

SCALE: 1/4"=1'-0" ON 22x34 AND 1/8"=1'-0" ON 11x17

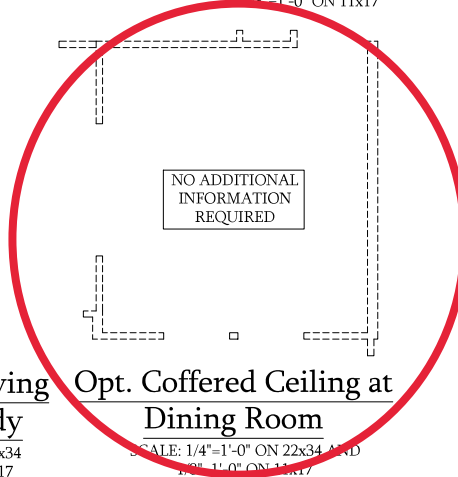

Opt. Coffered Ceiling at Dining Room

SCALE: 1/4"=1'-0" ON 22x34 AND 1/8"=1'-0" ON 11x17

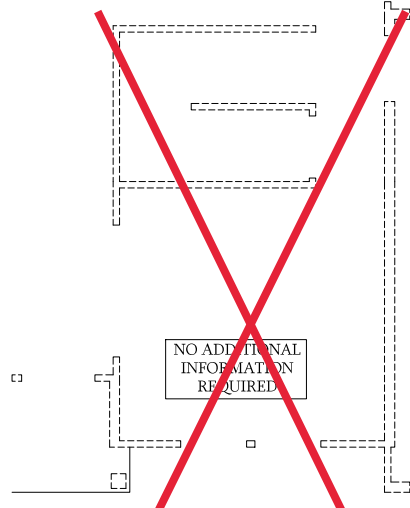

Dining Room w/ Opt. Basement

SCALE: 1/4"=1'-0" ON 22x34 AND 1/8"=1'-0" ON 11x17

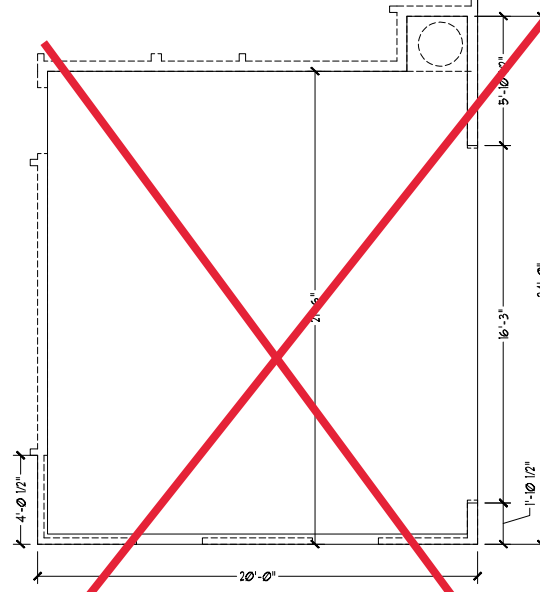

Optional 2-Car Side Load Garage

SCALE: 1/4"=1'-0" ON 22x34 AND 1/8"=1'-0" ON 11x17

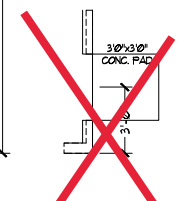

Optional Service Door at Garage

SCALE: 1/4"=1'-0" ON 22x34 AND 1/8"=1'-0" ON 11x17

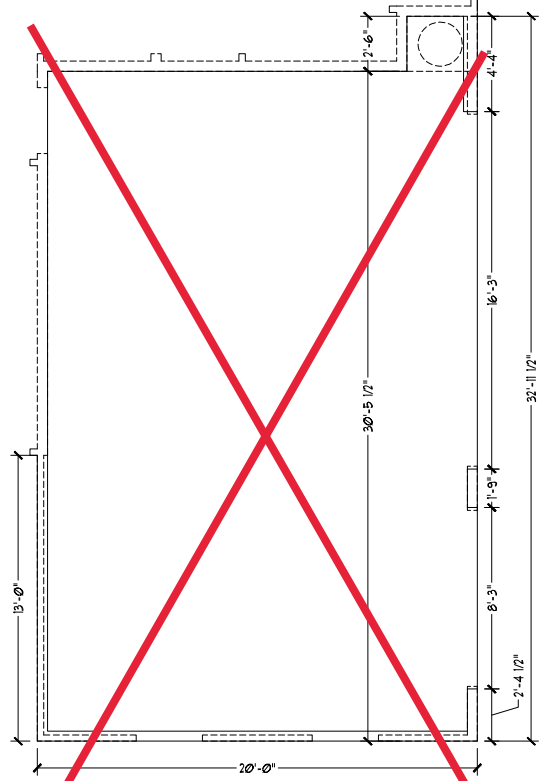

Optional 3-Car Side Load Garage

SCALE: 1/4"=1'-0" ON 22x34 AND 1/8"=1'-0" ON 11x17

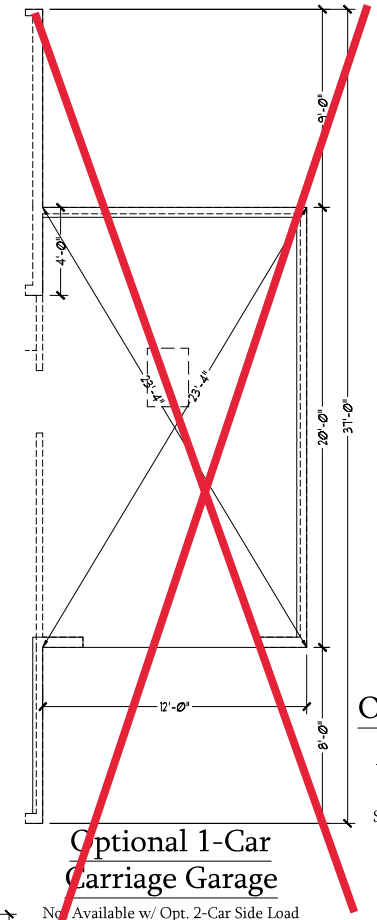

Optional 1-Car Carriage Garage

Not Available w/ Opt. 2-Car Side Load Garage or 3-Car Side Load Garage
SCALE: 1/4"=1'-0" ON 22x34 AND 1/8"=1'-0" ON 11x17



Optional Service Door at 1-Car Garage

SCALE: 1/4"=1'-0" ON 22x34 AND 1/8"=1'-0" ON 11x17



PRICES, PROMOTIONS, INCENTIVES, FEATURES, MATERIALS AND DIMENSIONS ARE SUBJECT TO CHANGE WITHOUT NOTICE. SOURCE FOOTAGE AND DIMENSIONS ARE ESTIMATED AND MAY VARY IN ACTUAL CONSTRUCTION. ACTUAL POSITION OF HOUSE ON LOT, VERTICAL CURB ELEVATION, FINISH GRADE, FLOOR PLANS AND ELEVATION DIMENSIONS ARE ARTIST CONCEPTIONS. FLOOR PLANS ARE THE COPYRIGHTED PROPERTY OF H&H HOMES. ANY USE, REPRODUCTION, ADAPTATION, OR DISPLAY OF THE PLANS IS STRICTLY PROHIBITED. REVIEW THESE SAMPLES FOR INFORMATION ONLY. CURRENT DETAILS COPYRIGHT © 2019 H&H HOMES

H&H HOMES, INC
SOUTHPORT

DATE: SEPTEMBER 16, 2019
REV.: AUGUST 01, 2021
SCALE: 1/4"=1'-0"
DRAWN BY:
ENGINEERED BY:
REVIEWED BY:

SLAB INTERFACE
PLAN - OPTIONS
A-4.1

FIREPLACE

COVERED PORCH

COFFERED CEILING

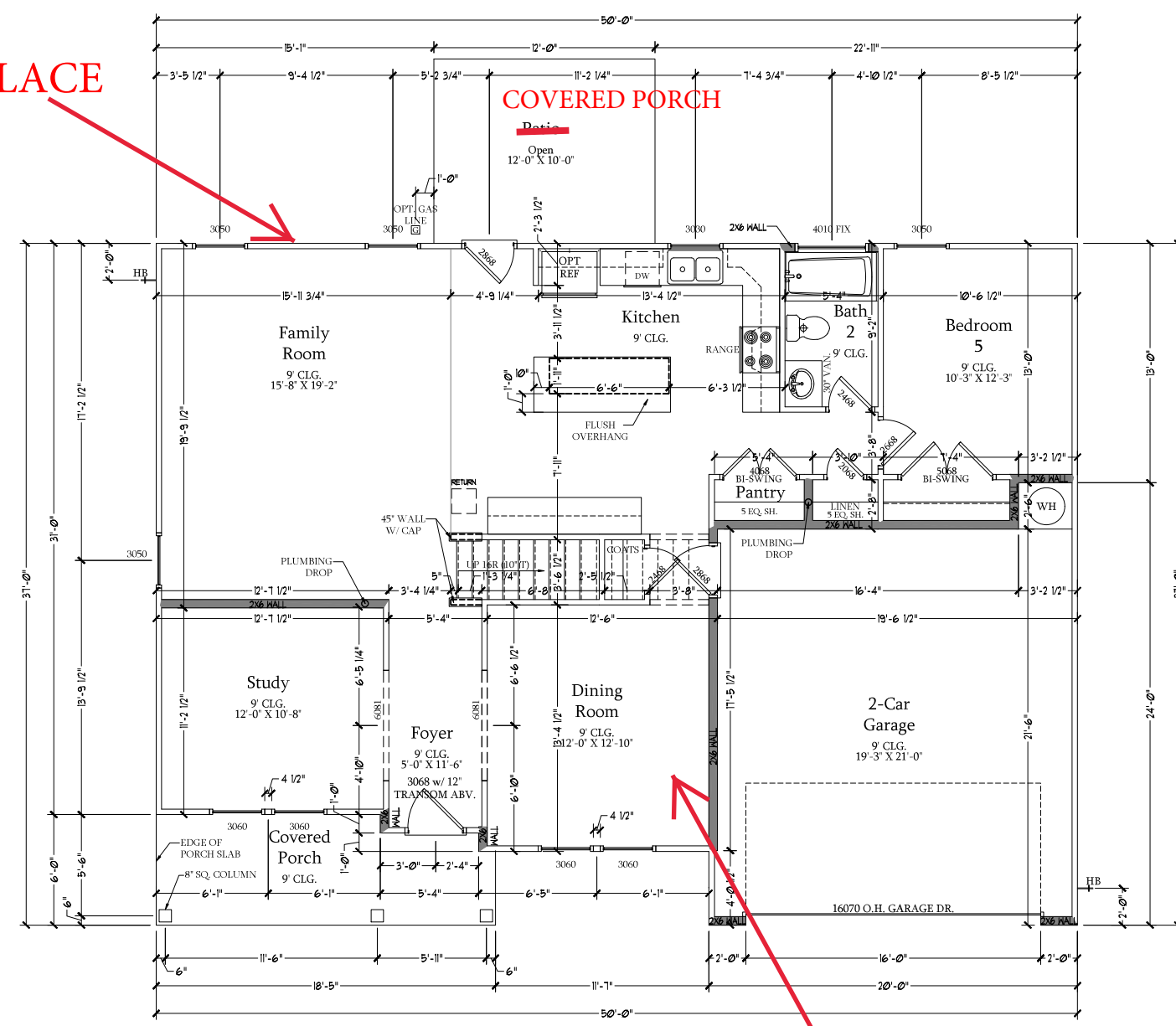

First Floor Plan
 SCALE: 1/4"=1'-0" ON 22x34 AND
 1/8"=1'-0" ON 11x17

SQUARE FOOTAGE	
1st FLOOR:	1269 SQ. FT.
2nd FLOOR:	1569 SQ. FT.
TOTAL:	2834 SQ. FT.
GARAGE:	430 SQ. FT.
FRONT PORCH:	104 SQ. FT.
PATIO:	100 SQ. FT.
OPT. BASEMENT:	1311 SQ. FT.
1st FLOOR OPTIONS	
OPTIONAL FIREPLACE:	10 SQ. FT.
1st FLOOR w/ OPT. BASEMENT:	31 SQ. FT.
2nd FLOOR OPTIONS	
2nd FLOOR w/ OPT. BASEMENT:	31 SQ. FT.
UNHEATED OPTIONS	
OPT. 1-CAR GARAGE:	240 SQ. FT.
OPT. 3-CAR GARAGE:	609 SQ. FT.
OPT. COVERED PATIO:	100 SQ. FT.
OPT. EXTENDED PATIO:	100 SQ. FT.

SQUARE FOOTAGE w/ BRICK VENEER	
1st FLOOR:	1321 SQ. FT.
2nd FLOOR:	1626 SQ. FT.
TOTAL:	2947 SQ. FT.
GARAGE:	430 SQ. FT.
FRONT PORCH:	104 SQ. FT.
PATIO:	100 SQ. FT.
OPT. BASEMENT:	1311 SQ. FT.
1st FLOOR OPTIONS	
OPTIONAL FIREPLACE:	15 SQ. FT.
1st FLOOR w/ OPT. BASEMENT:	25 SQ. FT.
2nd FLOOR OPTIONS	
2nd FLOOR w/ OPT. BASEMENT:	25 SQ. FT.
UNHEATED OPTIONS	
OPT. 1-CAR GARAGE:	250 SQ. FT.
OPT. 3-CAR GARAGE:	636 SQ. FT.
OPT. COVERED PATIO:	100 SQ. FT.
OPT. EXTENDED PATIO:	100 SQ. FT.



PRICES, PROMOTIONS, INCENTIVES, FEATURES, MATERIALS AND DIMENSIONS ARE SUBJECT TO CHANGE WITHOUT NOTICE. SQUARE FOOTAGE AND DIMENSIONS ARE ESTIMATED AND MAY VARY IN ACTUAL CONSTRUCTION. ACTUAL POSITION OF HOUSE ON LOT, WALL THICKNESS, WINDOW AND DOOR SIZES, FLOOR PLANS AND ELEVATION RENDERINGS ARE ARTIST CONCEPTIONS. FLOOR PLANS ARE THE COPYRIGHTED PROPERTY OF H&H HOMES. ANY USE, REPRODUCTION, ADAPTATION, OR DISPLAY OF THE PLANS IS STRICTLY PROHIBITED. REVIEW THESE SALES REPRESENTATIONS FOR CURRENT DETAILS. COPYRIGHT © 2019 H&H HOMES

H&H HOMES, INC
SOUTHPORT

DATE: SEPTEMBER 16, 2019
 REV.: AUGUST 01, 2021
 SCALE: 1/4"=1'-0"
 DRAWN BY:
 ENGINEERED BY:
 REVIEWED BY:

FIRST FLOOR
 PLAN
A-6

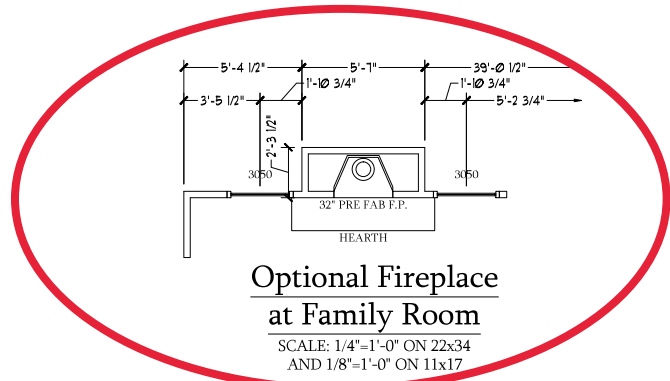

Optional Fireplace at Family Room

SCALE: 1/4"=1'-0" ON 22x34 AND 1/8"=1'-0" ON 11x17

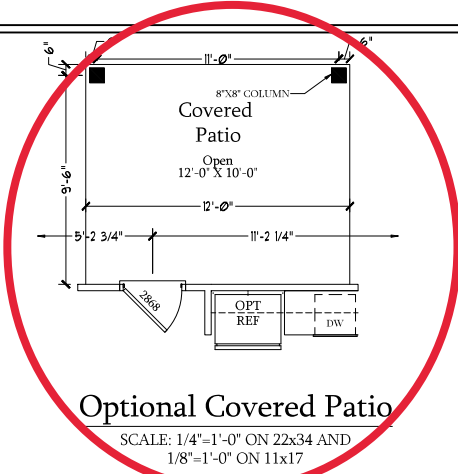

Optional Covered Patio

SCALE: 1/4"=1'-0" ON 22x34 AND 1/8"=1'-0" ON 11x17

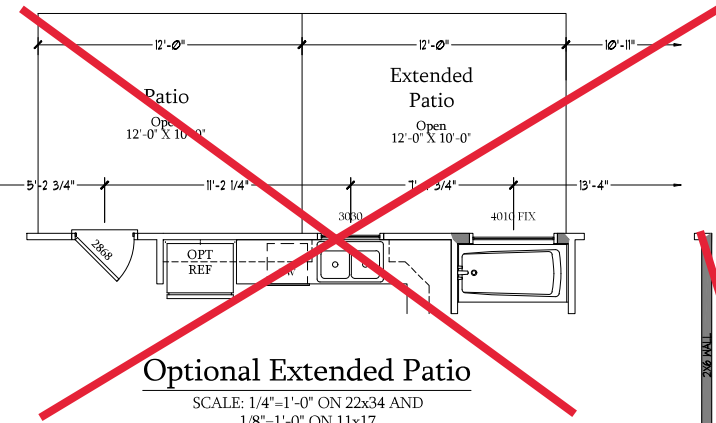

Optional Extended Patio

SCALE: 1/4"=1'-0" ON 22x34 AND 1/8"=1'-0" ON 11x17

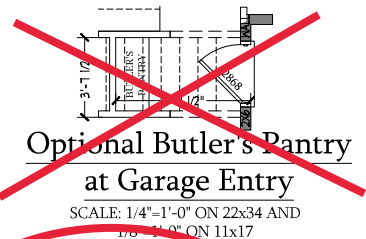

Optional Butler's Pantry at Garage Entry

SCALE: 1/4"=1'-0" ON 22x34 AND 1/8"=1'-0" ON 11x17

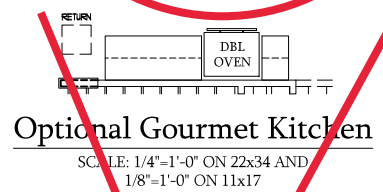

Optional Gourmet Kitchen

SCALE: 1/4"=1'-0" ON 22x34 AND 1/8"=1'-0" ON 11x17

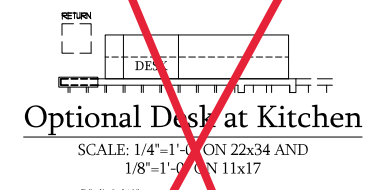

Optional Desk at Kitchen

SCALE: 1/4"=1'-0" ON 22x34 AND 1/8"=1'-0" ON 11x17

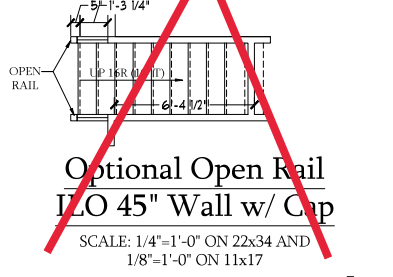

Optional Open Rail I/O 45" Wall w/ Cap

SCALE: 1/4"=1'-0" ON 22x34 AND 1/8"=1'-0" ON 11x17

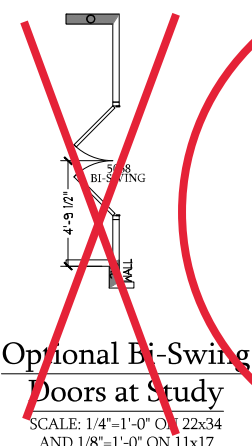

Optional Bi-Swing Doors at Study

SCALE: 1/4"=1'-0" ON 22x34 AND 1/8"=1'-0" ON 11x17

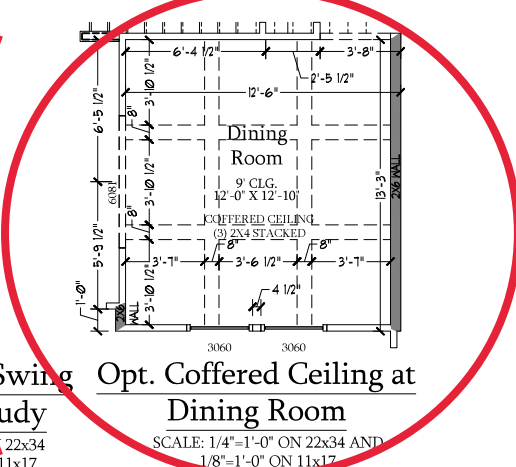

Optional Coffered Ceiling at Dining Room

SCALE: 1/4"=1'-0" ON 22x34 AND 1/8"=1'-0" ON 11x17

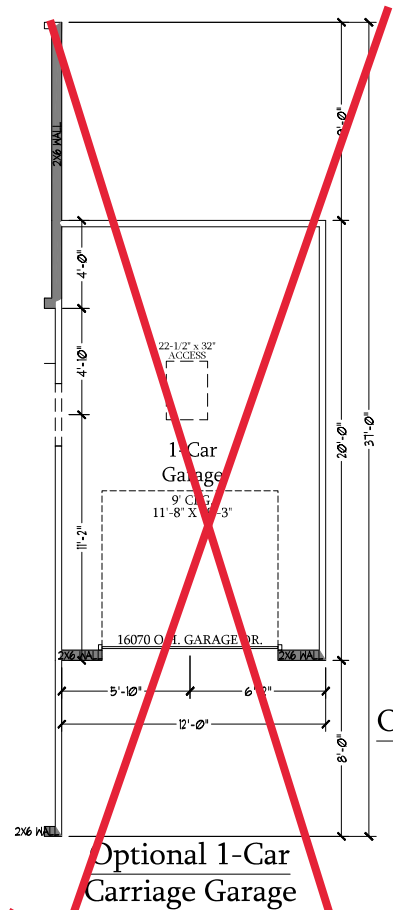

Optional 1-Car Carriage Garage

Not Available w/ Opt. 2-Car Side Load Garage or 3-Car Side Load Garage
SCALE: 1/4"=1'-0" ON 22x34 AND 1/8"=1'-0" ON 11x17

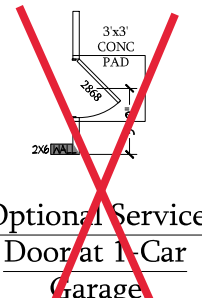

Optional Service Door at 1-Car Garage

SCALE: 1/4"=1'-0" ON 22x34 AND 1/8"=1'-0" ON 11x17

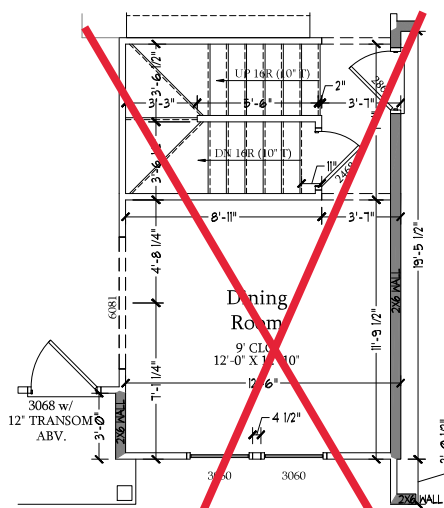

Optional Dining Room w/ Opt. Basement

SCALE: 1/4"=1'-0" ON 22x34 AND 1/8"=1'-0" ON 11x17

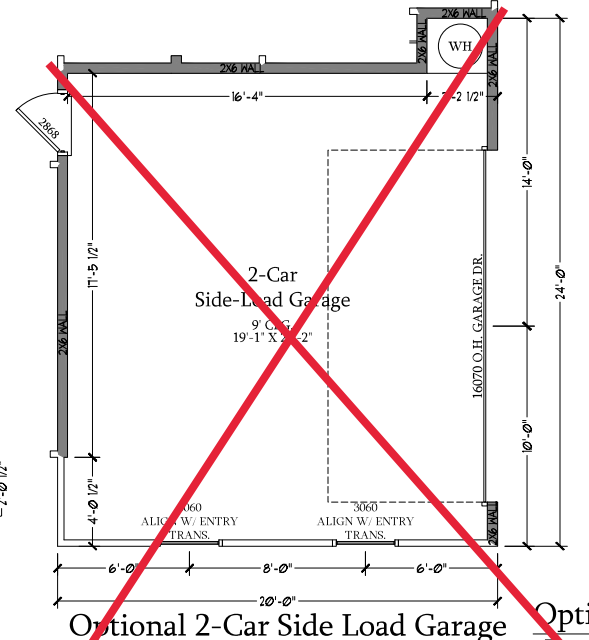

Optional 2-Car Side Load Garage

SCALE: 1/4"=1'-0" ON 22x34 AND 1/8"=1'-0" ON 11x17

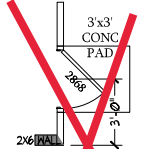

Optional Service Door at Garage

SCALE: 1/4"=1'-0" ON 22x34 AND 1/8"=1'-0" ON 11x17

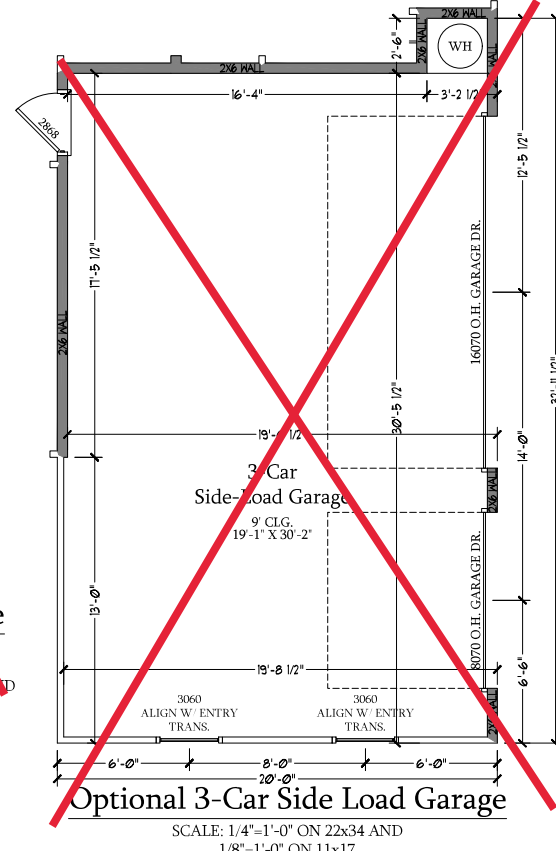

Optional 3-Car Side Load Garage

SCALE: 1/4"=1'-0" ON 22x34 AND 1/8"=1'-0" ON 11x17



PRICES, PROMOTIONS, INCENTIVES, FEATURES, FINANCING OFFERS AND SPECIALS ARE SUBJECT TO CHANGE WITHOUT NOTICE. SOURCE FOOTAGE AND DIMENSIONS ARE ESTIMATED AND MAY VARY IN ACTUAL CONSTRUCTION. ACTUAL POSITION OF HOUSE ON LOT, VERTICAL CURVES, ELEVATIONS, FINISHES, FLOOR PLANS AND ELEVATION RENDERINGS ARE ARTIST CONCEPTIONS. FLOOR PLANS ARE THE COPYRIGHTED PROPERTY OF H&H HOMES, INC. REPRODUCTION, ADAPTATION, OR DISPLAY OF THE PLANS IS STRICTLY PROHIBITED. REVIEW SALES REPRESENTATIVE FOR CURRENT DETAILS. COPYRIGHT © 2019 H&H HOMES

H&H HOMES, INC
SOUTHPORT

DATE: SEPTEMBER 16, 2019
REV.: AUGUST 01, 2021
SCALE: 1/4"=1'-0"
DRAWN BY:
ENGINEERED BY:
REVIEWED BY:

FIRST FLOOR
PLAN - OPTIONS
A-6.1

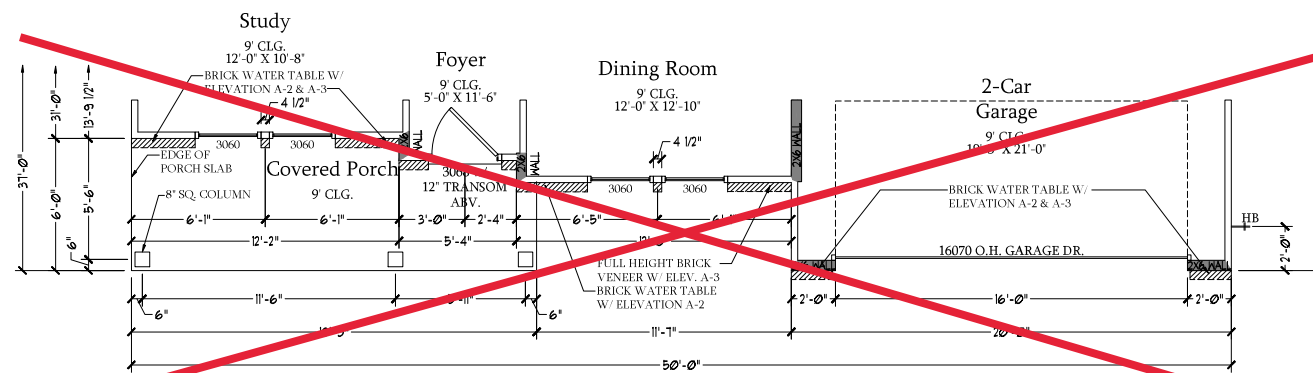

First Floor Plan
A-2 & A-3 Elev w/ Brick Front

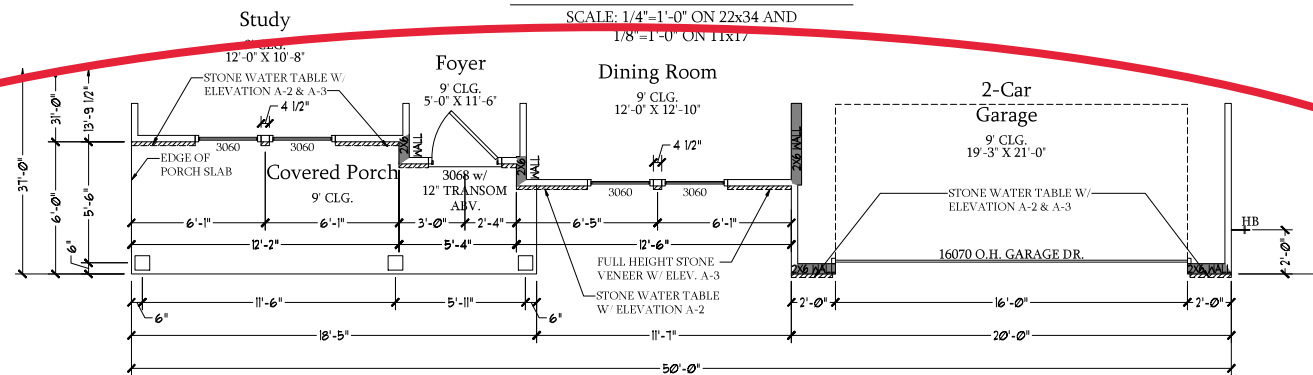

First Floor Plan
A-2 & A-3 Elev w/ Stone Front

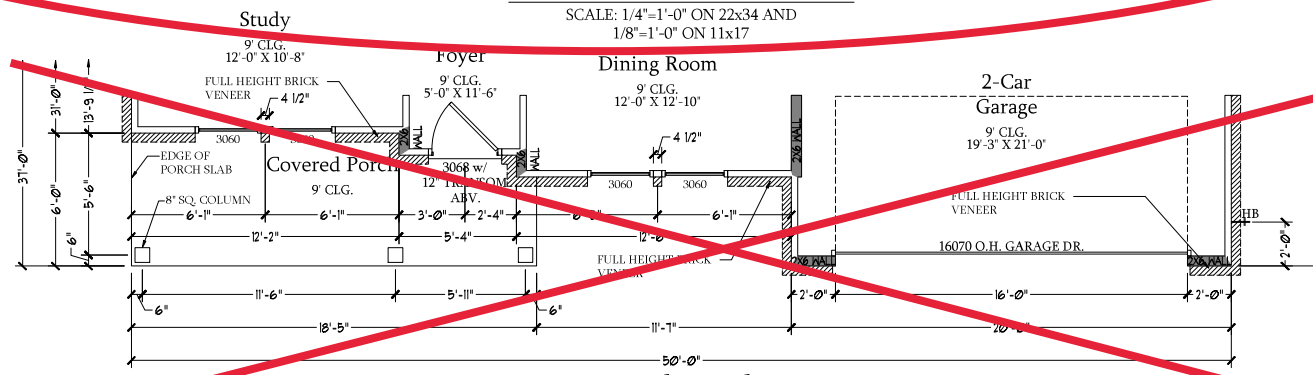

First Floor Plan
A-4 Elev



PRICES, PROMOTIONS, INCENTIVES, FEATURES, MATERIALS AND DIMENSIONS ARE SUBJECT TO CHANGE WITHOUT NOTICE. SOURCE FOOTAGE AND DIMENSIONS ARE ESTIMATED AND MAY VARY IN ACTUAL CONSTRUCTION. ACTUAL POSITION OF HOUSE ON LOT, WALL THICKNESS, FINISHES, ELEVATIONS, AND FLOOR PLANS AND ELEVATION RENDERINGS ARE ARTIST CONCEPTIONS. FLOOR PLANS ARE THE COPYRIGHTED PROPERTY OF H&H HOMES. ANY USE, REPRODUCTION, ADAPTATION, OR DISPLAY OF THE PLANS IS STRICTLY PROHIBITED. ELEVATION RENDERINGS ARE FOR INFORMATION ONLY. © 2019 H&H HOMES

H&H HOMES, INC
SOUTHPORT

DATE: SEPTEMBER 16, 2019
REV.: AUGUST 01, 2021
SCALE: 1/4"=1'-0"
DRAWN BY:
ENGINEERED BY:
REVIEWED BY:

A ELEVATION
FIRST FLOOR
PARTIAL PLANS

A-6.2

OWNERS BATH 2

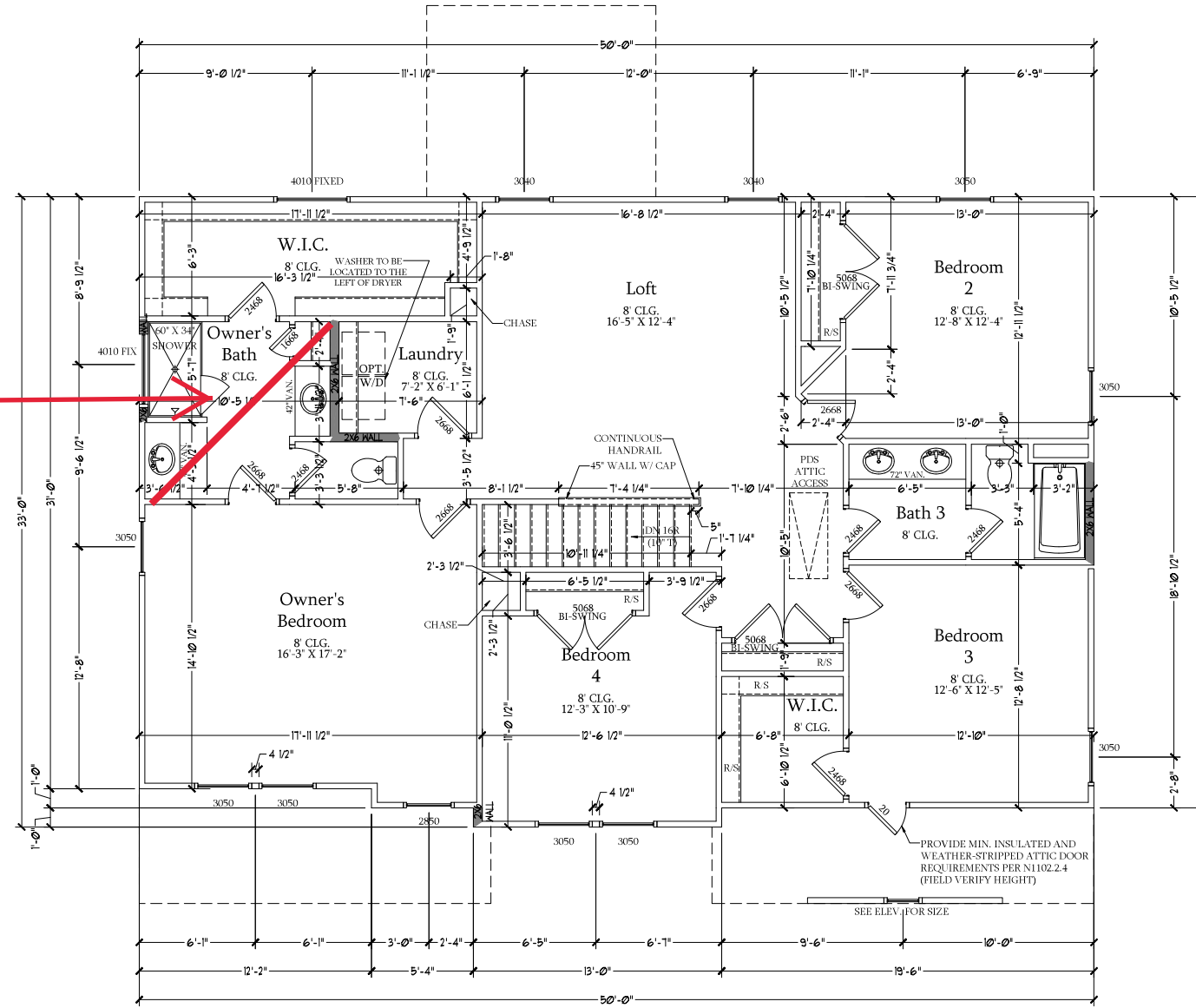

Second Floor Plan

SCALE: 1/4"=1'-0" ON 22x34 AND
1/8"=1'-0" ON 11x17



PRICES, PROMOTIONS, INCENTIVES, FEATURES, MATERIALS AND DIMENSIONS ARE SUBJECT TO CHANGE WITHOUT NOTICE. SOURCE FOOTAGE AND DIMENSIONS ARE ESTIMATED AND MAY VARY IN ACTUAL CONSTRUCTION. ACTUAL POSITION OF HOUSE ON LOT, WALL PLACEMENTS, WINDOW PLACEMENTS, FLOOR PLANS AND ELEVATION RENDERINGS ARE ARTIST CONCEPTIONS. FLOOR PLANS ARE THE COPYRIGHTED PROPERTY OF H&H HOMES. ANY USE, REPRODUCTION, ADAPTATION, OR DISPLAY OF THE PLANS IS STRICTLY PROHIBITED. THESE PLANS ARE SALES TOOLS ONLY. FOR CURRENT DETAILS, CONTACT H&H HOMES.

H&H HOMES, INC
SOUTHPORT

DATE: SEPTEMBER 16, 2019

REV.: AUGUST 01, 2021

SCALE: 1/4"=1'-0"

DRAWN BY:

ENGINEERED BY:

REVIEWED BY:

SECOND FLOOR
PLAN

A-7

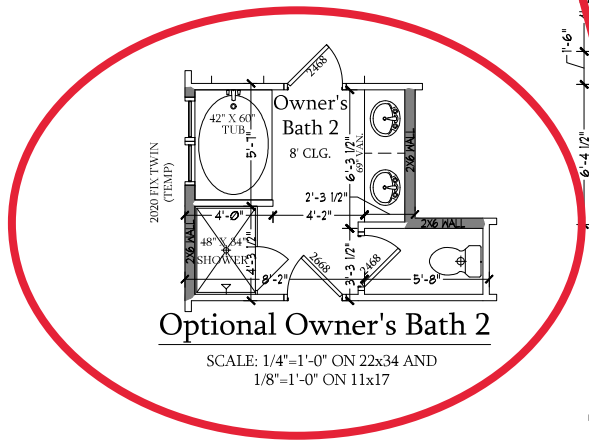

Optional Owner's Bath 2

SCALE: 1/4"=1'-0" ON 22x34 AND
1/8"=1'-0" ON 11x17

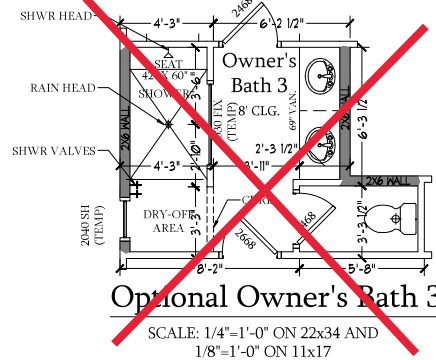

Optional Owner's Bath 3

SCALE: 1/4"=1'-0" ON 22x34 AND
1/8"=1'-0" ON 11x17

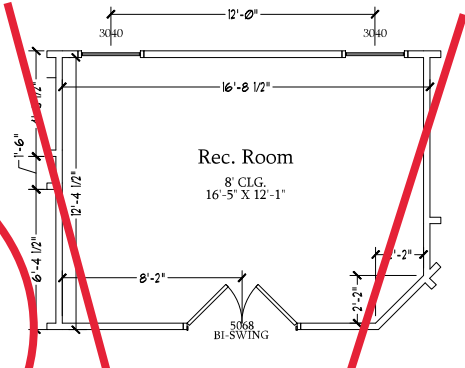

Optional Rec. Room ILO Loft

SCALE: 1/4"=1'-0" ON 22x34 AND
1/8"=1'-0" ON 11x17

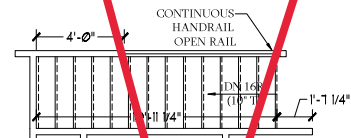

**Optional Open Rail ILO
45" Wall w/ Cap at Loft**

SCALE: 1/4"=1'-0" ON 22x34 AND
1/8"=1'-0" ON 11x17

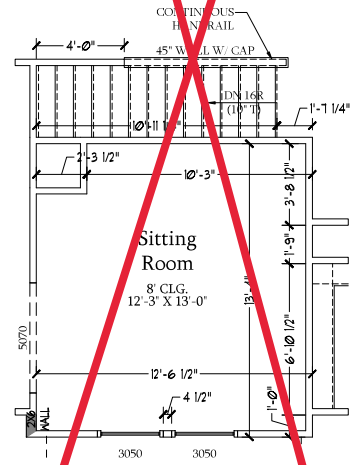

**Optional Sitting Room at
Owner's Bedroom ILO
Bedroom 4**

SCALE: 1/4"=1'-0" ON 22x34 AND
1/8"=1'-0" ON 11x17

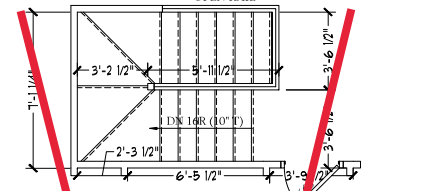

**Optional Open Rail ILO 45" Wall
w/ Cap at Loft w/ Opt. Basement**

SCALE: 1/4"=1'-0" ON 22x34 AND
1/8"=1'-0" ON 11x17

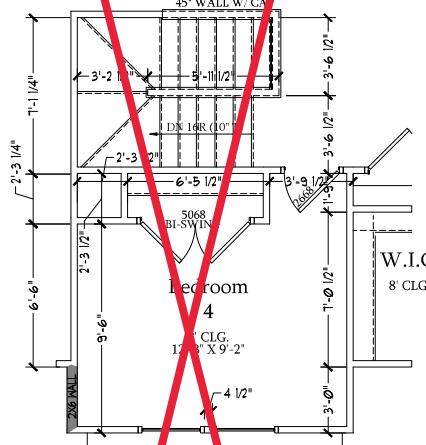

**Optional Bedroom 4 w/ Opt.
Basement**

SCALE: 1/4"=1'-0" ON 22x34 AND
1/8"=1'-0" ON 11x17

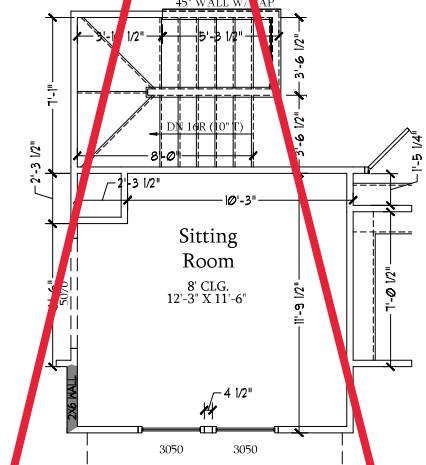

**Optional Sitting Room at Owner's
Bedroom ILO Bedroom 4 w/ Opt. Basement**

SCALE: 1/4"=1'-0" ON 22x34 AND
1/8"=1'-0" ON 11x17

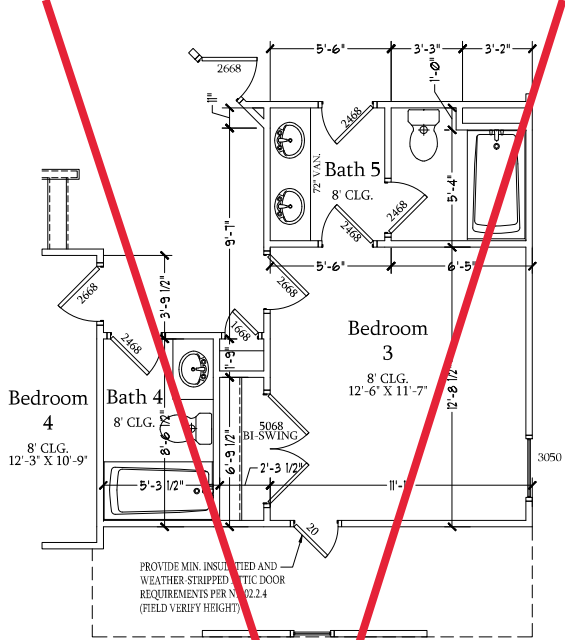

**Opt. Bath 5 w/ Bedroom 3
& Barn 4**

SCALE: 1/4"=1'-0" ON 22x34 AND
1/8"=1'-0" ON 11x17

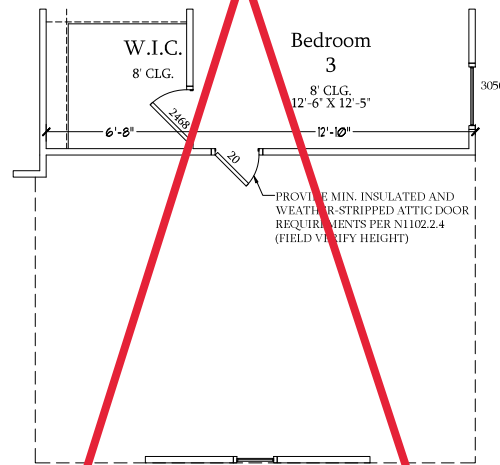

**Opt. 3-Car Side-Load
Garage**

SCALE: 1/4"=1'-0" ON 22x34 AND
1/8"=1'-0" ON 11x17



PRICES, PROMOTIONS, INCENTIVES, FEATURES, FINISHES, MATERIALS AND DIMENSIONS ARE SUBJECT TO CHANGE WITHOUT NOTICE. SOURCE FOOTAGE AND DIMENSIONS ARE ESTIMATED AND MAY VARY IN ACTUAL CONSTRUCTION. ACTUAL POSITION OF HOUSE ON LOT, VERTICAL CURVES, ELEVATIONS, FINISHES, FLOOR PLANS AND ELEVATION DIMENSIONS ARE ARTIST CONCEPTIONS. FLOOR PLANS ARE THE COPYRIGHTED PROPERTY OF H&H HOMES. ANY USE, REPRODUCTION, ADAPTATION, OR DISPLAY OF THE PLANS IS STRICTLY PROHIBITED. REVIEW THESE SALES REPRESENTATIONS FOR CURRENT DETAILS. COPYRIGHT © 2019 H&H HOMES

H&H HOMES, INC
SOUTHPORT

DATE: SEPTEMBER 16, 2019
REV.: AUGUST 01, 2021
SCALE: 1/4"=1'-0"
DRAWN BY:
ENGINEERED BY:
REVIEWED BY:

SECOND FLOOR
PLAN - OPTIONS
A-7.1

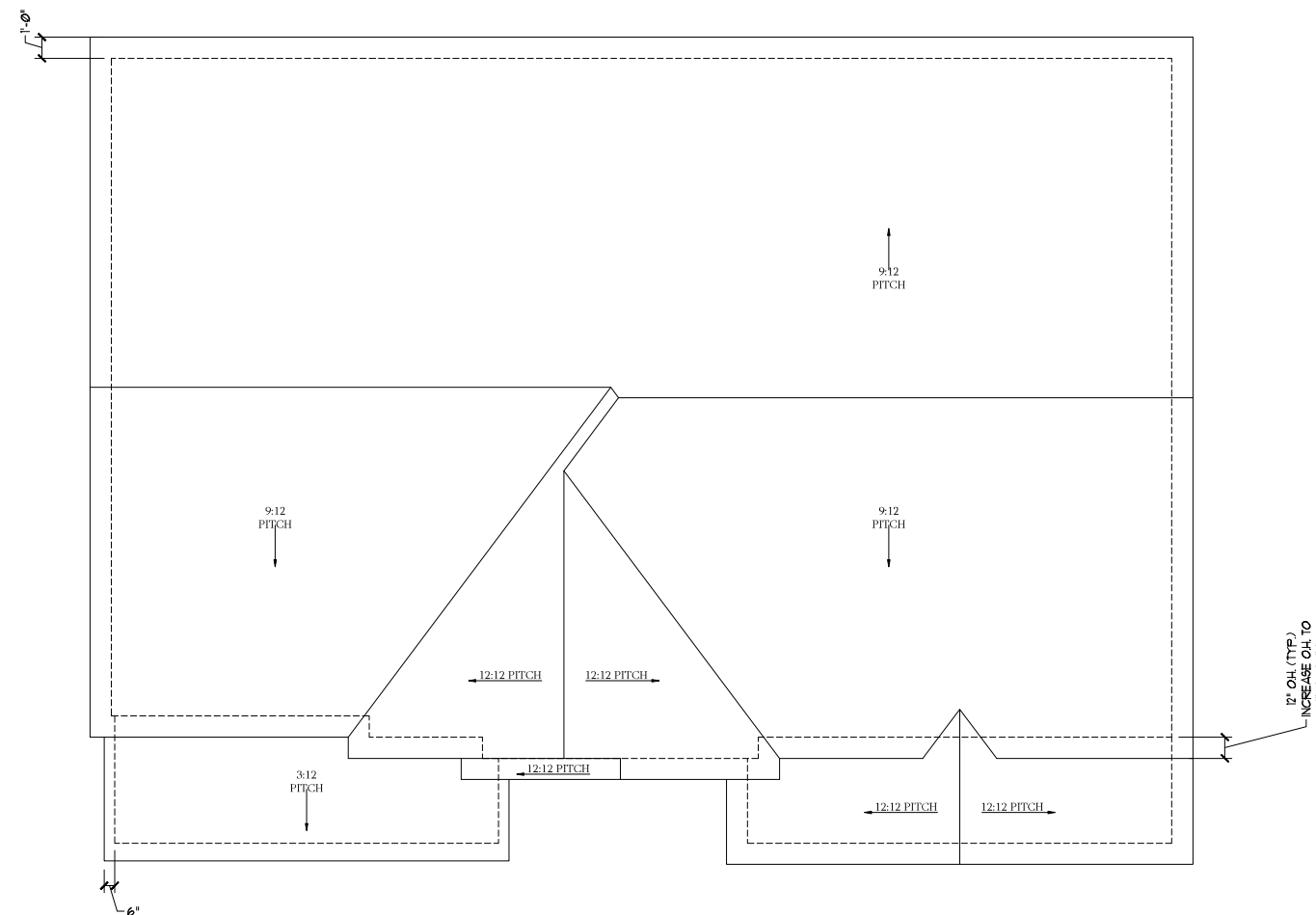

Roof Plan
Elevation A & B
 SCALE: 1/4"=1'-0" ON 22x34 AND
 1/8"=1'-0" ON 11x17

TOTAL UNDER ROOF AREA:	1600	SQ. FT.
VENTING AREA REQUIRED:	1600 SQ. FT. / 300 = 5.33	SQ. FT.
TOTAL REQUIREMENTS:	LOWER: 2.66 UPPER: 2.66	
LOWER AREA VENTING		
SOFFIT VENT	SIZE:	PER UNIT:
	-	.041 SF/LF
		# UNITS:
		70'-0"
		PROVIDED:
		2.87
LOWER AREA VENTING PROVIDED: -		
UPPER AREA VENTING		
RIDGE VENT	SIZE:	PER UNIT:
	-	.125 SF/LF
		# UNITS:
		49'-0"
		PROVIDED:
		6.125
UPPER AREA VENTING PROVIDED: -		
TOTAL AREA PROVIDED		
SOFFIT AND RIDGE VENT		10.162



PRICES, PROMOTIONS, INCENTIVES, FEATURES, MATERIALS AND DIMENSIONS ARE SUBJECT TO CHANGE WITHOUT NOTICE. SOURCE FOOTAGE AND DIMENSIONS ARE ESTIMATED AND MAY VARY IN ACTUAL CONSTRUCTION. ACTUAL POSITION OF HOUSE ON LOT, WALLS, FLOORING, CEILING, ROOFING, ETC. ARE LATEST CONCEPTIONS. FLOOR PLANS ARE THE COPYRIGHTED PROPERTY OF H&H HOMES. ANY USE, REPRODUCTION, ADAPTATION, OR DISPLAY OF THE PLANS IS STRICTLY PROHIBITED. REVIEW THESE PLANS CAREFULLY FOR CURRENT DETAILS. COPYRIGHT © 2018 H&H HOMES

H&H HOMES, INC
SOUTHPORT

DATE: SEPTEMBER 16, 2019
 REV.: AUGUST 01, 2021
 SCALE: 1/4"=1'-0"
 DRAWN BY:
 ENGINEERED BY:
 REVIEWED BY:

ELEVATIONS A &
 B ROOF PLAN

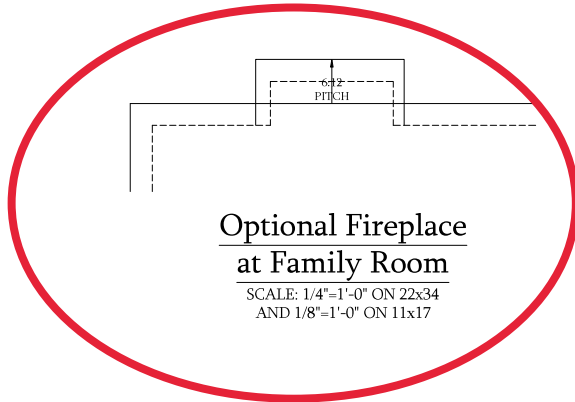

**Optional Fireplace
at Family Room**

SCALE: 1/4"=1'-0" ON 22x34
AND 1/8"=1'-0" ON 11x17

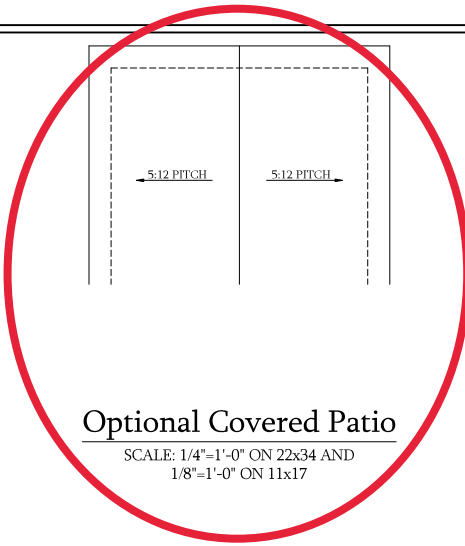

Optional Covered Patio

SCALE: 1/4"=1'-0" ON 22x34 AND
1/8"=1'-0" ON 11x17

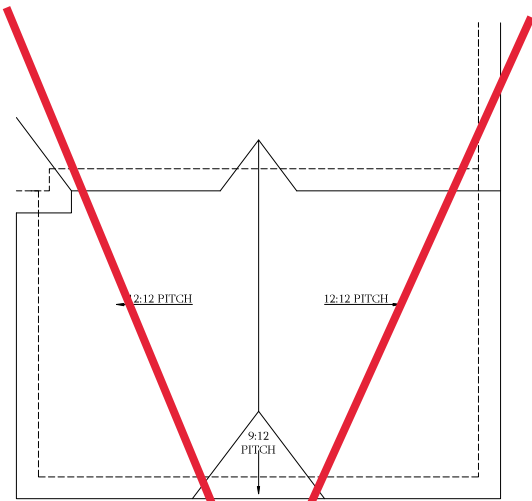

**Optional 3-Car Side Load Garage
Elevation C**

SCALE: 1/4"=1'-0" ON 22x34 AND
1/8"=1'-0" ON 11x17

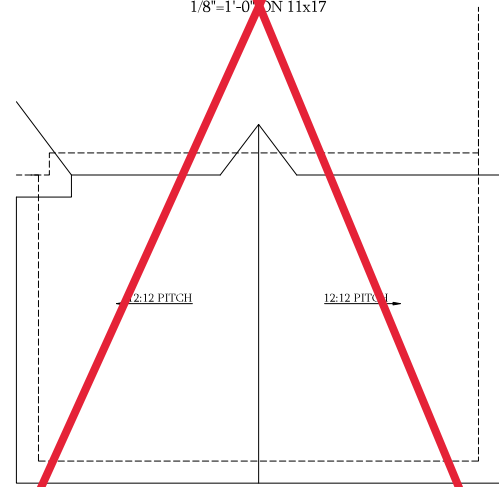

**Optional 3-Car Side Load Garage
Elevation A & B**

SCALE: 1/4"=1'-0" ON 22x34 AND
1/8"=1'-0" ON 11x17

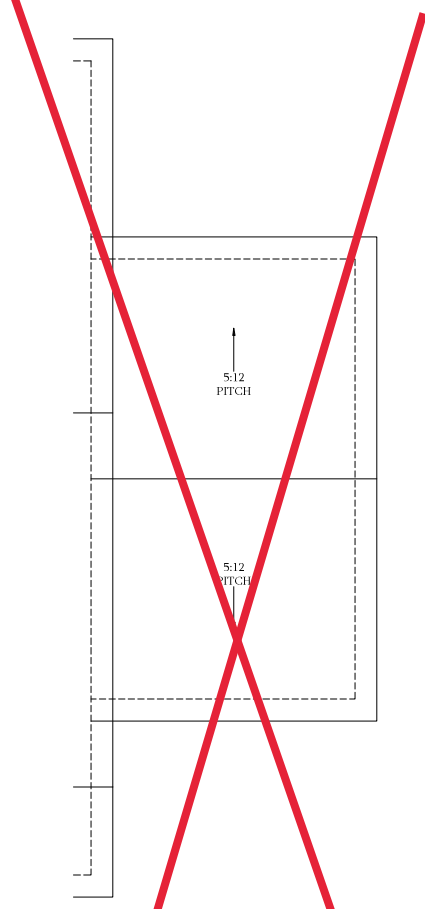

**Optional 1-Car
Carriage Garage
Elevation A & B**

Not Available w/ Opt. 2-Car Side Load
Garage or 3-Car Side Load Garage
SCALE: 1/4"=1'-0" ON 22x34 AND
1/8"=1'-0" ON 11x17

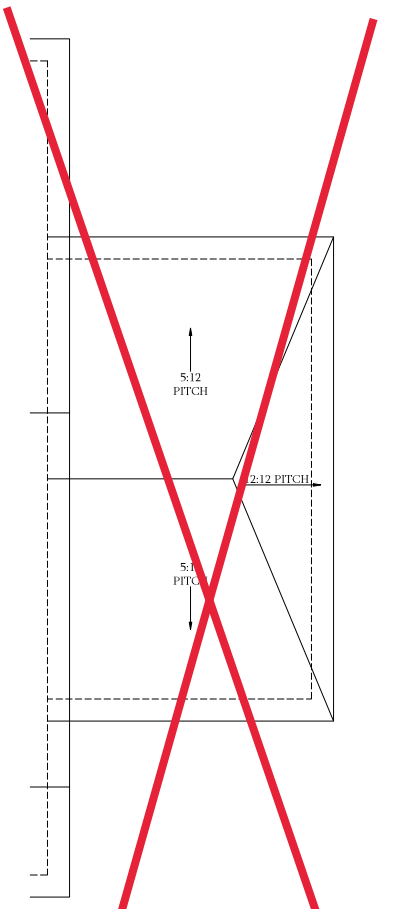

**Optional 1-Car
Carriage Garage
Elevation C**

Not Available w/ Opt. 2-Car Side Load
Garage or 3-Car Side Load Garage
SCALE: 1/4"=1'-0" ON 22x34 AND
1/8"=1'-0" ON 11x17



PRICES, PROMOTIONS, INCENTIVES, FEATURES,
FINISHES, MATERIALS, DIMENSIONS, LOADS,
AND DIMENSIONS ARE SUBJECT TO CHANGE
WITHOUT NOTICE. SOURCE FOOTAGE AND DIMENSIONS
ARE ESTIMATED AND MAY VARY IN ACTUAL
CONSTRUCTION. ACTUAL POSITION OF HOUSE ON LOT
MAY VARY FROM THAT SHOWN. ALL DIMENSIONS
FLOOR PLANS AND ELEVATION RENDERINGS ARE ARTIST
CONCEPTIONS. FLOOR PLANS ARE THE COPYRIGHTED
PROPERTY OF H&H HOMES. ANY USE, REPRODUCTION,
ADAPTATION, OR DISPLAY OF THE PLANS IS STRICTLY
PROHIBITED. NEW PLAN SALES ARE STRICTLY FOR
CURRENT DETAILS. COPYRIGHT © 2019 H&H HOMES

H&H HOMES, INC
SOUTHPORT

DATE: SEPTEMBER 16, 2019
REV.: AUGUST 01, 2021
SCALE: 1/4"=1'-0"
DRAWN BY:
ENGINEERED BY:
REVIEWED BY:

ROOF PLAN
OPTIONS
A-8.2

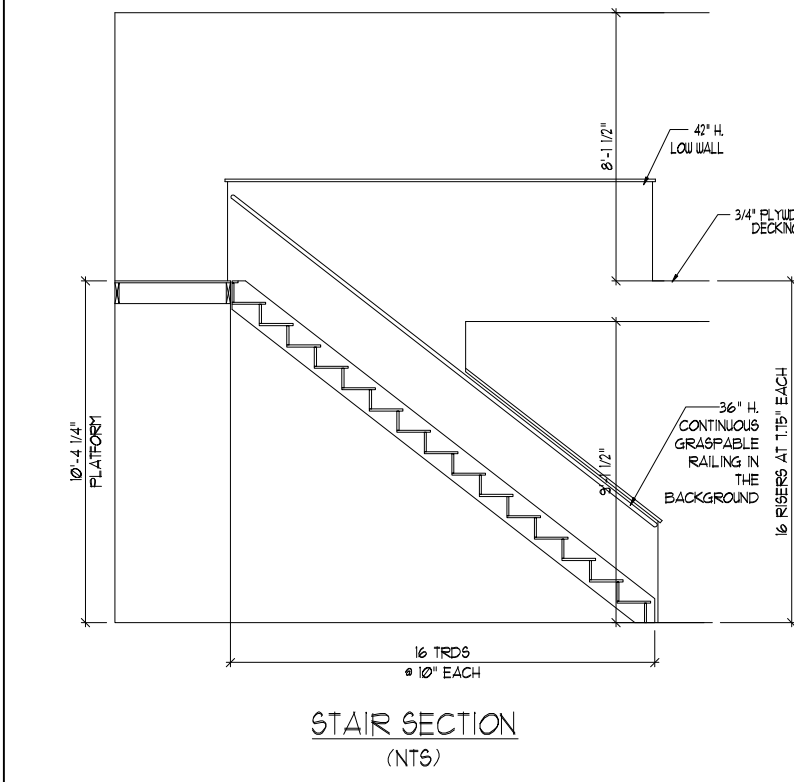
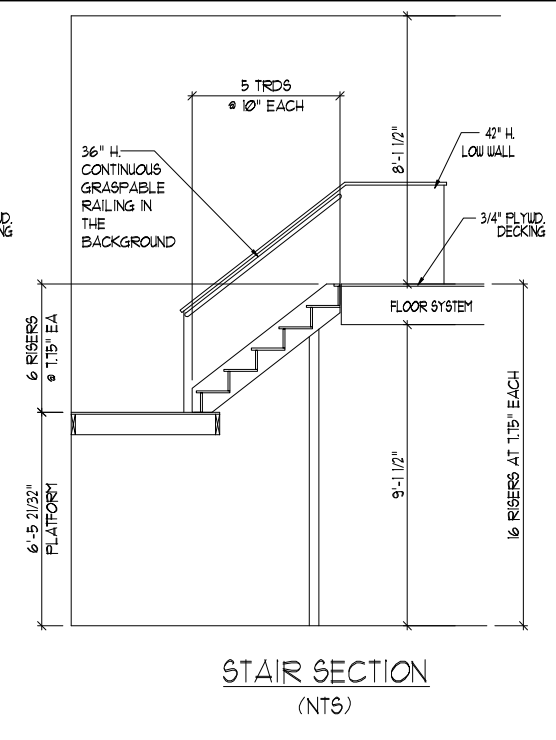
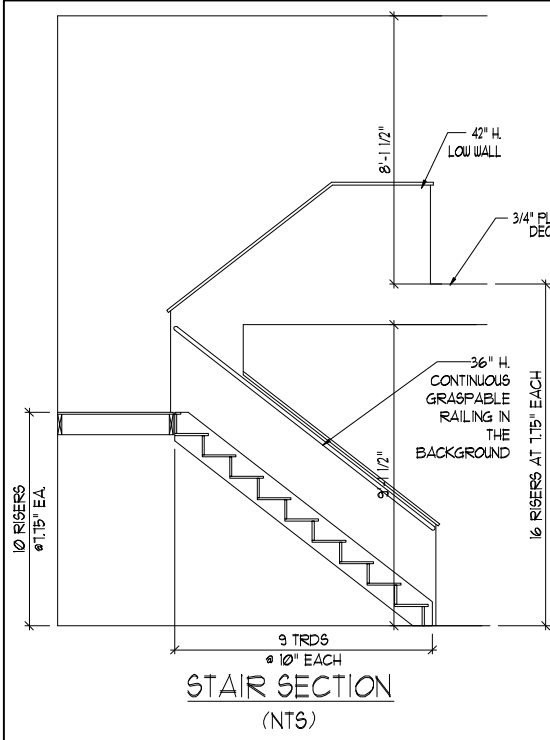

*** * * * ***
STAIR NOTES:
RAILING
 BALUSTERS SHALL BE SPACED SO THAT A 4" SPHERE CANNOT PASS THROUGH.
 THE TRIANGULAR OPENINGS FORMED BY THE RISER, TREAD AND BOTTOM RAIL OF A GUARD AT THE OPEN SIDE OF A STAIRWAY ARE PERMITTED TO BE A SUCH A SIZE THAT A SPHERE OF 6 INCHES CANNOT PASS THROUGH.
 OPENINGS FOR REQUIRED GUARDS ON THE SIDES OF STAIR TREADS SHALL NOT ALLOW A SPHERE 4 3/8 INCHES TO PASS THROUGH.
HANDRAILS:
 HANDRAILS FOR STAIRWAYS SHALL BE CONTINUOUS FOR THE FULL LENGTH OF THE FLIGHT, FROM A POINT DIRECTLY ABOVE THE TOP RISER OF THE FLIGHT TO A POINT DIRECTLY ABOVE THE LOWEST RISER. HANDRAIL ENDS SHALL BE RETURNED OR SHALL TERMINATE IN NEWEL POSTS OR SAFETY TERMINALS.
 HANDRAILS ADJACENT TO A WALL SHALL HAVE A SPACE OF NOT LESS THAN 1-1/2 INCH BETWEEN THE WALL AND HANDRAILS.
 CONTINUOUS GRASPABLE HANDRAIL MUST MEET TYPE ONE OR TYPE TWO CRITERIA
*** * * * ***

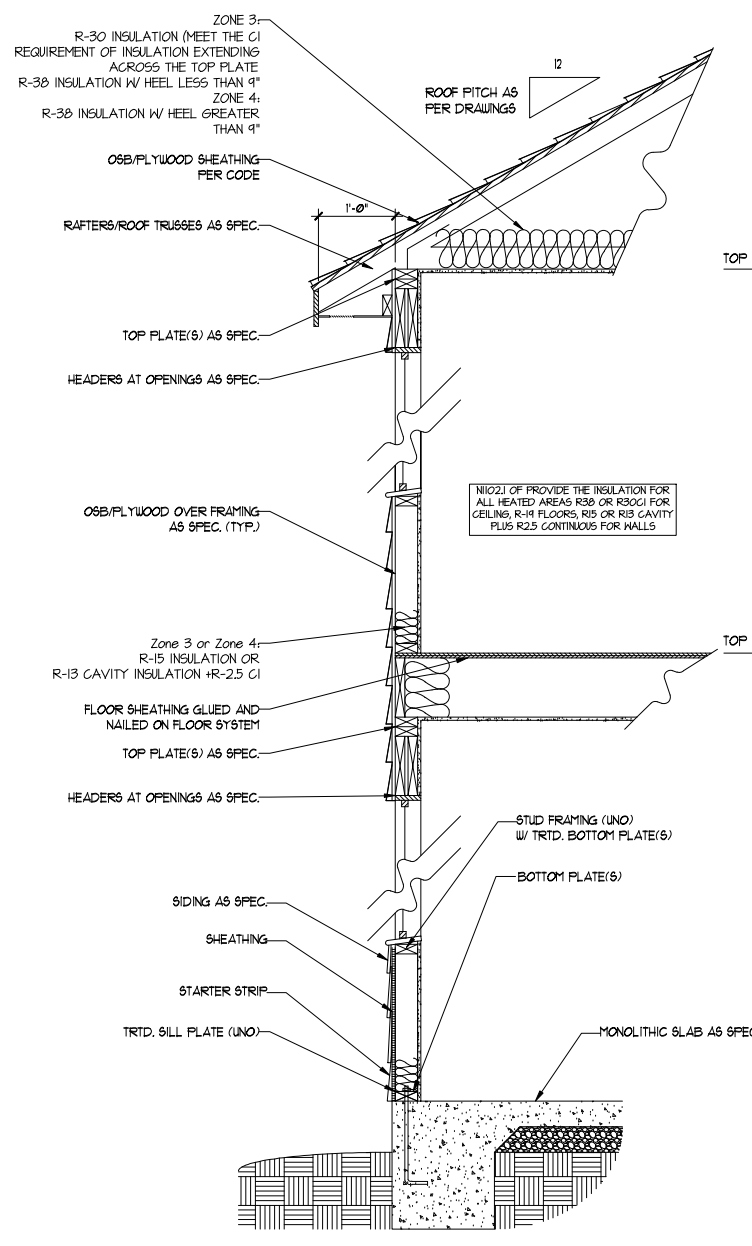

**WALL SECTION W/ SLAB
 W/ STD. SIDING SHOWN (NTS)**

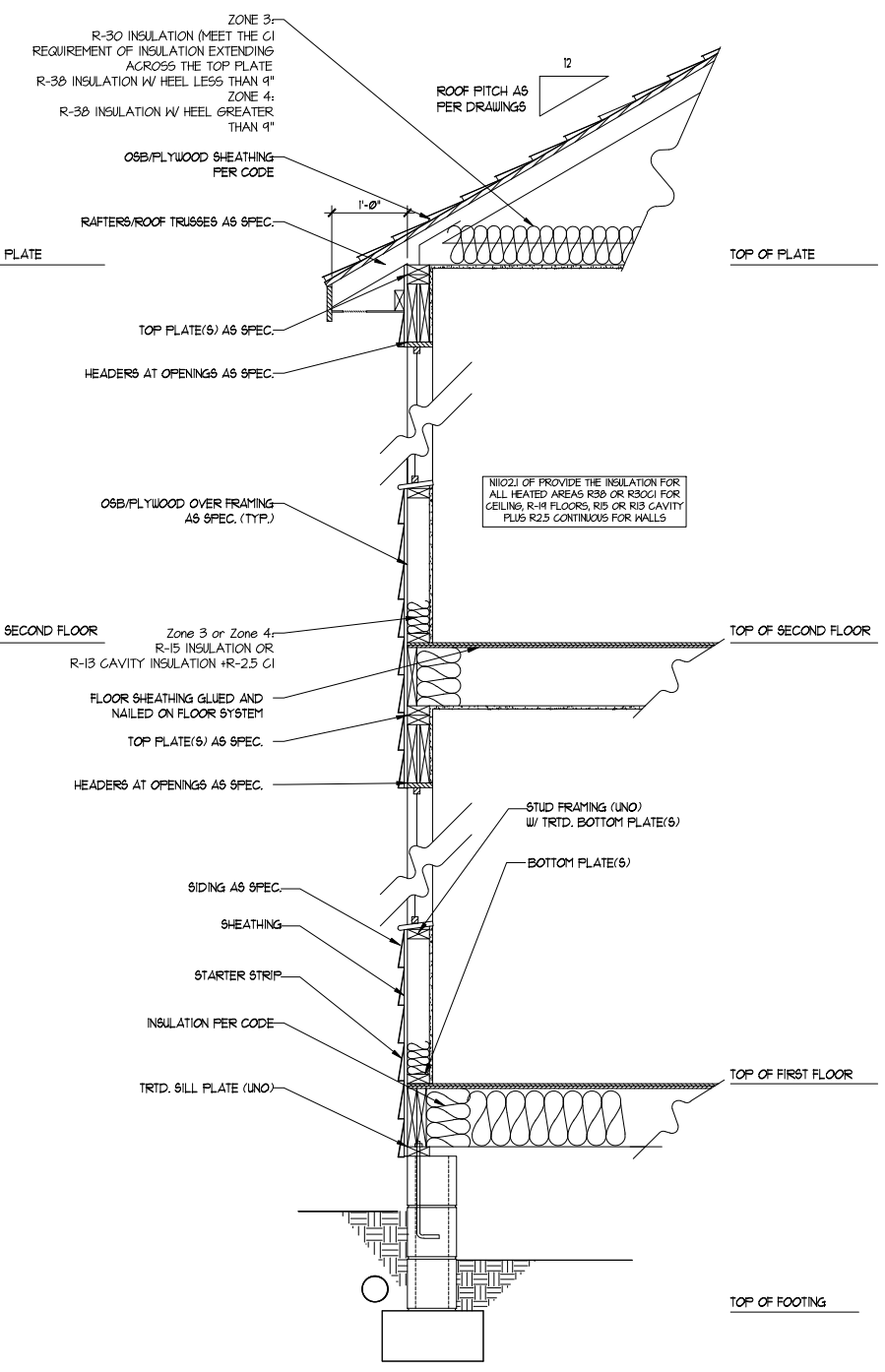

**WALL SECTION W/ CRAWL SPACE
 W/ STD. SIDING SHOWN (NTS)**



PRICES, PROMOTIONS, INCENTIVES, FEATURES, MATERIALS AND DIMENSIONS ARE SUBJECT TO CHANGE WITHOUT NOTICE. SQUARE FOOTAGE AND DIMENSIONS ARE ESTIMATED AND MAY VARY IN ACTUAL CONSTRUCTION. ACTUAL POSITION OF HOUSE ON LOT, VERTICAL CURVES, ELEVATIONS, FINISHES, LATEST FLOOR PLANS AND ELEVATION RENDERINGS ARE LATEST CONCEPTIONS. FLOOR PLANS ARE THE COPYRIGHTED PROPERTY OF H&H HOMES. ANY USE, REPRODUCTION, ADAPTATION, OR DISPLAY OF THE PLANS IS STRICTLY PROHIBITED. REVIEW THESE PLANS CAREFULLY FOR CURRENT DETAILS. COPYRIGHT © 2019 H&H HOMES

H&H HOMES, INC
SOUTHPORT

DATE: SEPTEMBER 16, 2019
 REV.: AUGUST 01, 2021
 SCALE: 1/4"=1'-0"
 DRAWN BY:
 ENGINEERED BY:
 REVIEWED BY:

**WALL SECTIONS
 AND STAIR
 DETAIL**

AD-1

ELECTRICAL LEGEND

- 120V OUTLET
- 120V GFI OUTLET
- 120V SWITCHED OUTLET
- 120V BASEBOARD OUTLET
- 4-PLEX
- FLOOR MOUNTED 120V
- WEATHERPROOF
- 220V OUTLET
- 120V DEDICATED CIRCUIT
- 220V DEDICATED CIRCUIT
- SPECIAL PURPOSE (240 V, ETC.)
- WALL MOUNT LIGHT
- CEILING MOUNT LIGHT
- PENDANT LIGHT
- RECESSED CAN LIGHT
- MINI CAN LIGHT
- EYEBALL LIGHT
- FLUORESCENT LIGHT
- UNDERCABINET LIGHT
- FLOOD LIGHT
- SWITCH
- 3-WAY SWITCH
- 4-WAY SWITCH
- DIMMER SWITCH
- TELEPHONE
- TV CONNECTION
- CONDUIT FOR COMPONENT WIRING
- SPEAKER
- COMBO SMOKE/ CARBON MONOXIDE DETECTOR
- 110 V SMOKE DETECTOR
- EXHAUST FAN
- LOW VOLTAGE PANEL
- CEILING FAN
- CEILING FAN W/ LIGHT

ELECTRICAL NOTES:

1. PROVIDE AND INSTALL GROUND FAULT CIRCUIT-INTERRUPTERS (G.F.I.) AS INDICATED ON PLANS OR AS ITEM NO. 4 AND 5 BELOW INDICATES.
2. UNLESS OTHERWISE INDICATED, INSTALL SWITCHES AND RECEPTACLES AT THE FOLLOWING HEIGHTS ABOVE FINISHED FLOOR:
SWITCHES... 42"
OUTLETS... 14"
TELEPHONE... 14" (UNLESS ABOVE COUNTERTOP)
TELEVISION... 14"
3. ALL SMOKE DETECTORS SHALL BE HARDWIRED INTO AN ELECTRICAL POWER SOURCE AND SHALL BE EQUIPPED WITH A MONITORED BATTERY BACKUP. PROVIDE AND INSTALL LOCALLY CERTIFIED SMOKE DETECTORS.
4. ALL 15A AND 20A RECEPTACLES IN SLEEPING ROOMS, FAMILY ROOMS, DINING ROOMS, LIVING ROOMS, PARLORS, LIBRARIES, DENS, SUNROOMS, RECREATION ROOMS, CLOSETS, HALLWAYS, AND SIMILAR AREAS WILL REQUIRE A COMBINATION TYPE A.F.C.I. DEVICE AND TAMPER-PROOF RECEPTACLES.
5. ALL 15A AND 20A 120V RECEPTACLES LOCATED IN THE GARAGE AND UTILITY ROOMS SHALL BE G.F.C.I. PROTECTED (G.F.I.).
6. IT IS THE RESPONSIBILITY OF THE LICENSED ELECTRICIAN TO ENSURE THAT ALL ELECTRICAL WORK IS IN FULL COMPLIANCE WITH ALL APPLICABLE LOCAL STANDARDS, CODES, AND ORDINANCES.
7. EVERY BUILDING HAVING A FOSSIL-FUEL-BURNING HEATER OR APPLIANCE, FIREPLACE, OR AN ATTACHED GARAGE SHALL HAVE AN OPERATIONAL CARBON MONOXIDE DETECTOR INSTALLED WITHIN 10 FEET OF EACH ROOM USED FOR SLEEPING PURPOSES.
8. ALARMS SHALL RECEIVE THEIR PRIMARY POWER FROM THE BUILDING WIRING WHEN SUCH WIRING IS SERVED FROM THE LOCAL POWER UTILITY. SUCH ALARMS SHALL HAVE BATTERY BACKUP. COMBINATION SMOKE/CARBON MONOXIDE ALARMS SHALL BE LISTED OR LABELED BY A NATIONALLY RECOGNIZED TESTING LABORATORY.

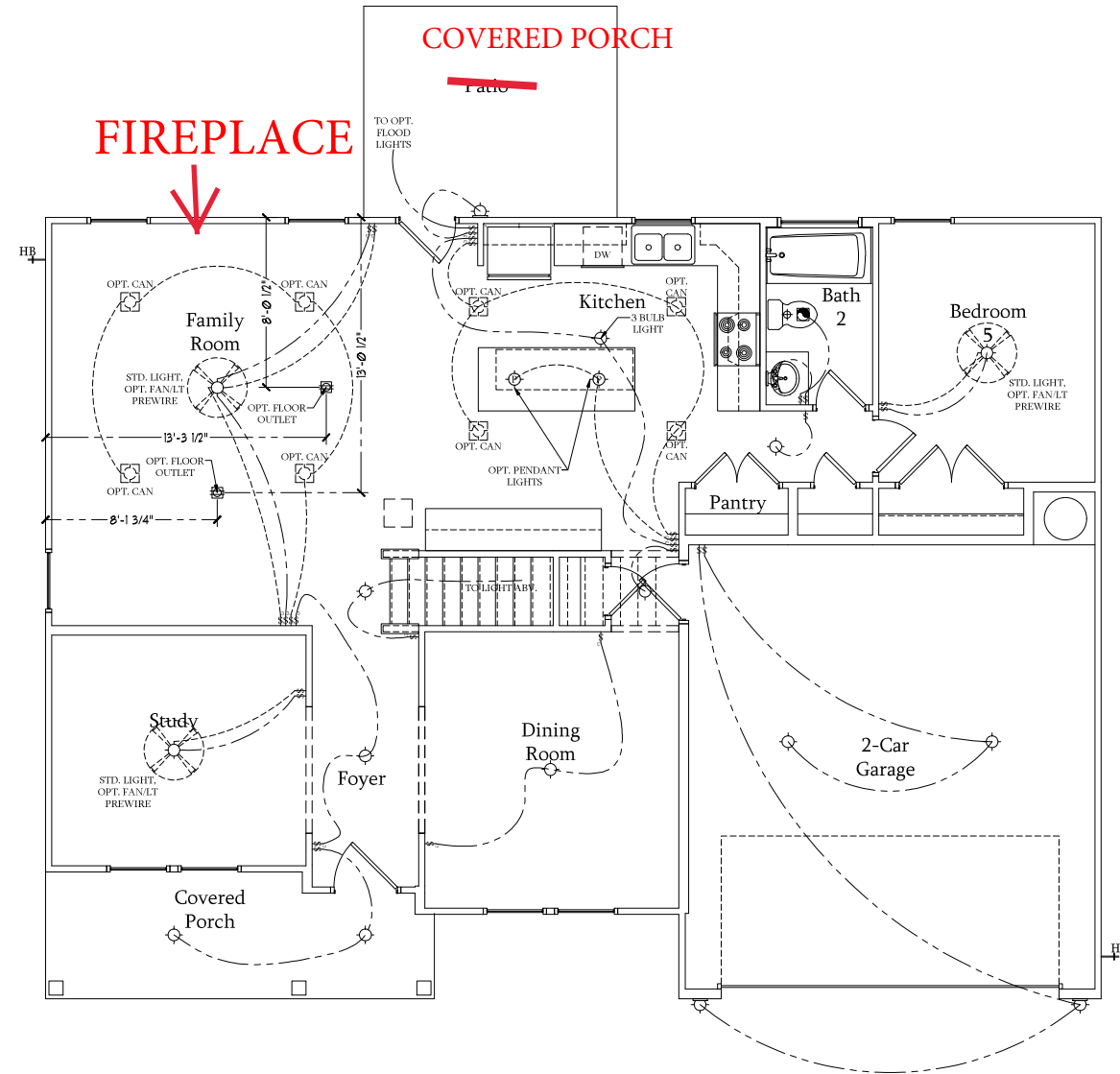

First Floor Plan
SCALE: 1/4"=1'-0" ON 22x34 AND
1/8"=1'-0" ON 11x17



PRICES, PROMOTIONS, INCENTIVES, FEATURES, MATERIALS AND DIMENSIONS ARE SUBJECT TO CHANGE WITHOUT NOTICE. SOURCE FOOTAGE AND DIMENSIONS ARE ESTIMATED AND MAY VARY IN ACTUAL CONSTRUCTION. ACTUAL POSITION OF HOUSE ON LOT, VERTICAL CURVES, ELEVATIONS, FINISHES, AND FLOOR PLANS AND ELEVATION DIMENSIONS ARE LATEST CONCEPTIONS. FLOOR PLANS ARE THE COPYRIGHTED PROPERTY OF H&H HOMES. ANY USE, REPRODUCTION, ADAPTATION, OR DISPLAY OF THE PLANS IS STRICTLY PROHIBITED. REVIEW THESE SALES TERMS AND CONDITIONS FOR CURRENT DETAILS. COPYRIGHT © 2019 H&H HOMES

H&H HOMES, INC
SOUTHPORT

DATE: SEPTEMBER 16, 2019
REV.: AUGUST 01, 2021
SCALE: 1/4"=1'-0"
DRAWN BY:
ENGINEERED BY:
REVIEWED BY:

FIRST FLOOR
ELECTRICAL
PLAN

ELECTRICAL LEGEND

- 120V OUTLET
- 120V GFI OUTLET
- 120V SWITCHED OUTLET
- 120V BASEBOARD OUTLET
- 4-PLEX
- FLOOR MOUNTED 120V
- FLOOR MOUNTED 120V GFI
- WEATHERPROOF
- 220V OUTLET
- 120V DEDICATED CIRCUIT
- 220V DEDICATED CIRCUIT
- SPECIAL PURPOSE (240 V, ETC.)
- WALL MOUNT LIGHT
- CEILING MOUNT LIGHT
- PENDANT LIGHT
- RECESSED CAN LIGHT
- MINI CAN LIGHT
- EYEBALL LIGHT
- FLUORESCENT LIGHT
- UNDERCABINET LIGHT
- FLOOD LIGHT
- SWITCH
- 3-WAY SWITCH
- 4-WAY SWITCH
- DIMMER SWITCH
- TELEPHONE
- TV CONNECTION
- CONDUIT FOR COMPONENT WIRING
- SPEAKER
- COMBO SMOKE/ CARBON MONOXIDE DETECTOR
- 110 V SMOKE DETECTOR
- EXHAUST FAN
- LOW VOLTAGE PANEL

- CEILING FAN
- CEILING FAN W/ LIGHT

ELECTRICAL NOTES:

1. PROVIDE AND INSTALL GROUND FAULT CIRCUIT-INTERRUPTERS (G.F.I.) AS INDICATED ON PLANS OR AS ITEM NO. 4 AND 5 BELOW INDICATES.
2. UNLESS OTHERWISE INDICATED, INSTALL SWITCHES AND RECEPTACLES AT THE FOLLOWING HEIGHTS ABOVE FINISHED FLOOR: SWITCHES... 42" OUTLETS... 14" TELEPHONE... 14" (UNLESS ABOVE COUNTERTOP) TELEVISION... 14"
3. ALL SMOKE DETECTORS SHALL BE HARDWIRED INTO AN ELECTRICAL POWER SOURCE AND SHALL BE EQUIPPED WITH A MONITORED BATTERY BACKUP. PROVIDE AND INSTALL LOCALLY CERTIFIED SMOKE DETECTORS.
4. ALL 15A AND 20A RECEPTACLES IN SLEEPING ROOMS, FAMILY ROOMS, DINING ROOMS, LIVING ROOMS, PARLORS, LIBRARIES, DEN, SUNROOMS, RECREATION ROOMS, CLOSETS, HALLWAYS, AND SIMILAR AREAS WILL REQUIRE A COMBINATION TYPE A.F.C.I. DEVICE AND TAMPER-PROOF RECEPTACLES.
5. ALL 15A AND 20A 120V RECEPTACLES LOCATED IN THE GARAGE AND UTILITY ROOMS SHALL BE G.F.C.I. PROTECTED (G.F.I.).
6. IT IS THE RESPONSIBILITY OF THE LICENSED ELECTRICIAN TO ENSURE THAT ALL ELECTRICAL WORK IS IN FULL COMPLIANCE WITH ALL APPLICABLE LOCAL STANDARDS, CODES, AND ORDINANCES.
7. EVERY BUILDING HAVING A FOSSIL-FUEL-BURNING HEATER OR APPLIANCE, FIREPLACE, OR AN ATTACHED GARAGE SHALL HAVE AN OPERATIONAL CARBON MONOXIDE DETECTOR INSTALLED WITHIN 10 FEET OF EACH ROOM USED FOR SLEEPING PURPOSES.
8. ALARMS SHALL RECEIVE THEIR PRIMARY POWER FROM THE BUILDING WIRING WHEN SUCH WIRING IS SERVED FROM THE LOCAL POWER UTILITY. SUCH ALARMS SHALL HAVE BATTERY BACKUP. COMBINATION SMOKE/ CARBON MONOXIDE ALARMS SHALL BE LISTED OR LABELED BY A NATIONALLY RECOGNIZED TESTING LABORATORY.

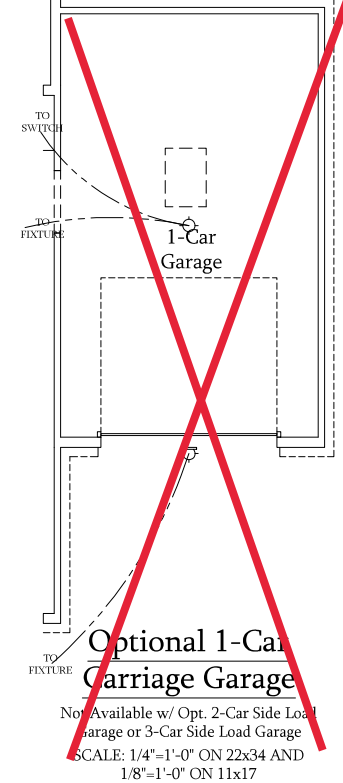
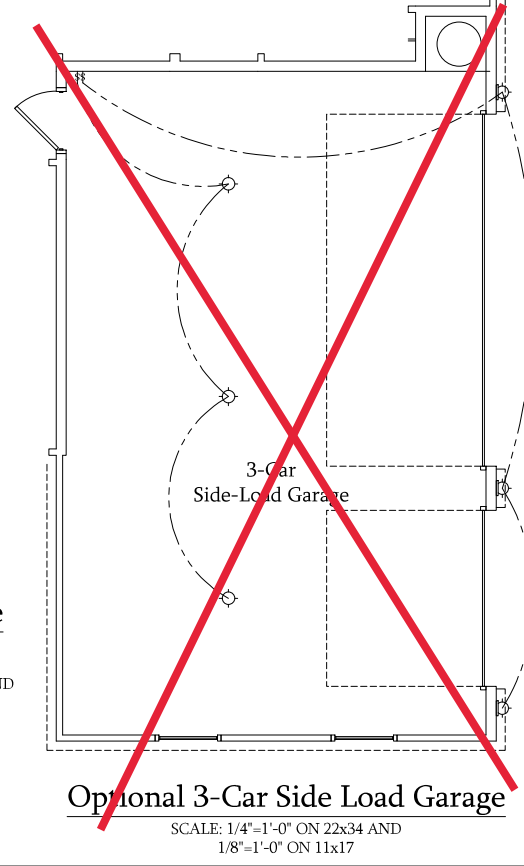
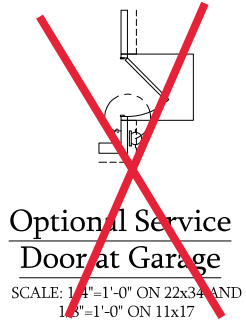
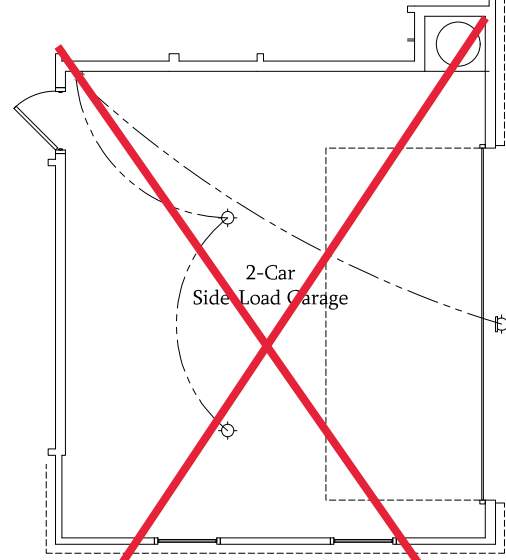
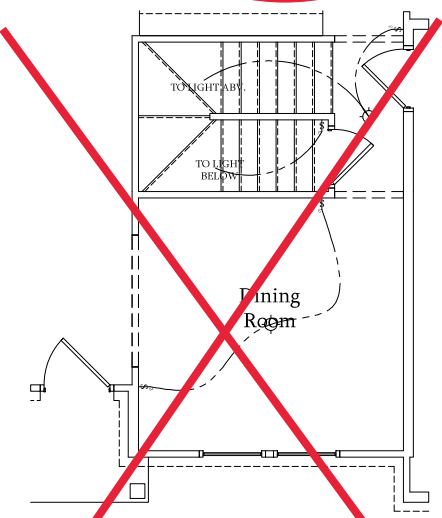
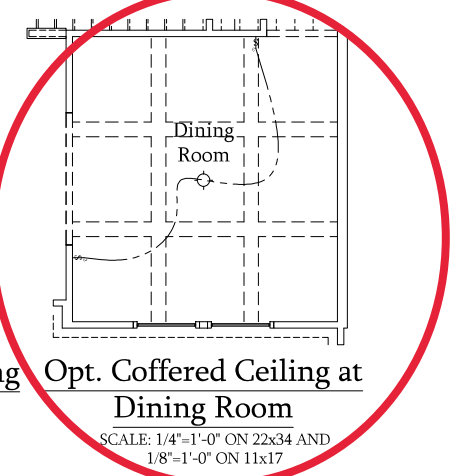
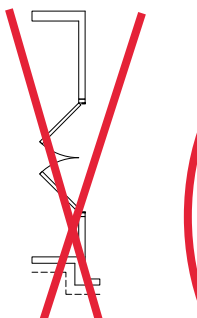
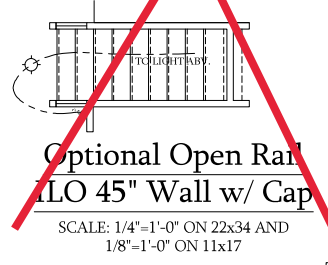
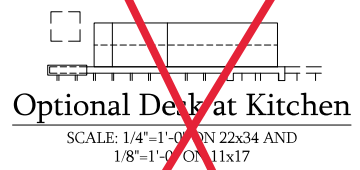
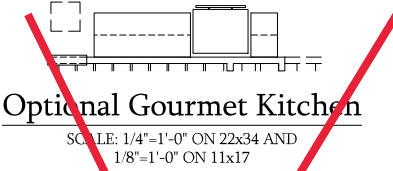
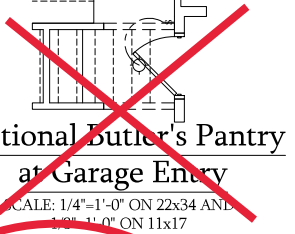
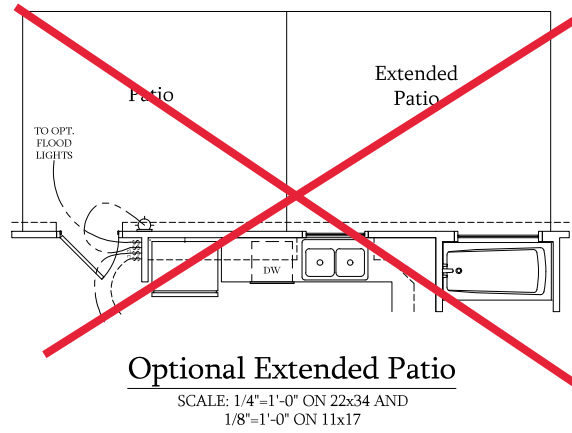
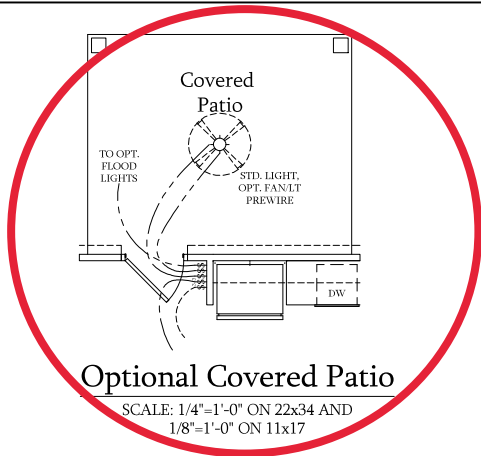

PRICES, PROMOTIONS, INCENTIVES, FEATURES, MATERIALS AND DIMENSIONS ARE SUBJECT TO CHANGE WITHOUT NOTICE. SOURCE FOOTAGE AND DIMENSIONS ARE ESTIMATED AND MAY VARY IN ACTUAL CONSTRUCTION. ACTUAL POSITION OF HOUSE ON LOT, VERTICAL CURVATURE OF EARTH, AND LOCAL PLANNING DEPARTMENTS' REGULATIONS ARE LATEST. CONCEPTS, FLOOR PLANS ARE THE COPYRIGHTED PROPERTY OF H&H HOMES. ANY USE, REPRODUCTION, ADAPTATION, OR DISPLAY OF THE PLANS IS STRICTLY PROHIBITED. REVIEW BY SALES REPRESENTATIVE FOR CURRENT DETAILS. COPYRIGHT © 2018 H&H HOMES

H&H HOMES, INC
SOUTHPORT

DATE: SEPTEMBER 16, 2019
REV.: AUGUST 01, 2021
SCALE: 1/4"=1'-0"
DRAWN BY:
ENGINEERED BY:
REVIEWED BY:

FIRST FLOOR ELECTRICAL PLAN - OPTIONS

E-1.1

ELECTRICAL LEGEND

- 120V OUTLET
- 120V GFI OUTLET
- 120V SWITCHED OUTLET
- 120V BASEBOARD OUTLET
- 4-PLEX
- FLOOR MOUNTED 120V
- WEATHERPROOF
- 220V OUTLET
- 120V DEDICATED CIRCUIT
- 220V DEDICATED CIRCUIT
- SPECIAL PURPOSE (240 V, ETC.)
- WALL MOUNT LIGHT
- CEILING MOUNT LIGHT
- PENDANT LIGHT
- RECESSED CAN LIGHT
- MINI CAN LIGHT
- EYEBALL LIGHT
- FLUORESCENT LIGHT
- UNDERCABINET LIGHT
- FLOOD LIGHT
- SWITCH
- 3-WAY SWITCH
- 4-WAY SWITCH
- DIMMER SWITCH
- TELEPHONE
- TV CONNECTION
- CONDUIT FOR COMPONENT WIRING
- SPEAKER
- COMBO SMOKE/CARBON MONOXIDE DETECTOR
- 110 V SMOKE DETECTOR
- EXHAUST FAN
- LOW VOLTAGE PANEL
- CEILING FAN
- CEILING FAN W/ LIGHT

ELECTRICAL NOTES:

1. PROVIDE AND INSTALL GROUND FAULT CIRCUIT-INTERRUPTERS (G.F.I.) AS INDICATED ON PLANS OR AS ITEM NO. 4 AND 5 BELOW INDICATES.
2. UNLESS OTHERWISE INDICATED, INSTALL SWITCHES AND RECEPTACLES AT THE FOLLOWING HEIGHTS ABOVE FINISHED FLOOR:
SWITCHES . . . 42"
OUTLETS . . . 14"
TELEPHONE . . . 14" (UNLESS ABOVE COUNTERTOP)
TELEVISION . . . 14"
3. ALL SMOKE DETECTORS SHALL BE HARDWIRED INTO AN ELECTRICAL POWER SOURCE AND SHALL BE EQUIPPED WITH A MONITORED BATTERY BACKUP. PROVIDE AND INSTALL LOCALLY CERTIFIED SMOKE DETECTORS.
4. ALL 15A AND 20A RECEPTACLES IN SLEEPING ROOMS, FAMILY ROOMS, DINING ROOMS, LIVING ROOMS, PARLORS, LIBRARIES, DENS, SUNROOMS, RECREATION ROOMS, CLOSETS, HALLWAYS, AND SIMILAR AREAS WILL REQUIRE A COMBINATION TYPE A.F.C.I. DEVICE AND TAMPER-PROOF RECEPTACLES.
5. ALL 15A AND 20A 120V RECEPTACLES LOCATED IN THE GARAGE AND UTILITY ROOMS SHALL BE G.F.C.I. PROTECTED (G.F.I.).
6. IT IS THE RESPONSIBILITY OF THE LICENSED ELECTRICIAN TO ENSURE THAT ALL ELECTRICAL WORK IS IN FULL COMPLIANCE WITH ALL APPLICABLE LOCAL STANDARDS, CODES, AND ORDINANCES.
7. EVERY BUILDING HAVING A FOSSIL-FUEL-BURNING HEATER OR APPLIANCE, FIREPLACE, OR AN ATTACHED GARAGE SHALL HAVE AN OPERATIONAL CARBON MONOXIDE DETECTOR INSTALLED WITHIN 10 FEET OF EACH ROOM USED FOR SLEEPING PURPOSES.
8. ALARMS SHALL RECEIVE THEIR PRIMARY POWER FROM THE BUILDING WIRING WHEN SUCH WIRING IS SERVED FROM THE LOCAL POWER UTILITY. SUCH ALARMS SHALL HAVE BATTERY BACKUP. COMBINATION SMOKE/CARBON MONOXIDE ALARMS SHALL BE LISTED OR LABELED BY A NATIONALLY RECOGNIZED TESTING LABORATORY.

OWNERS BATH 2

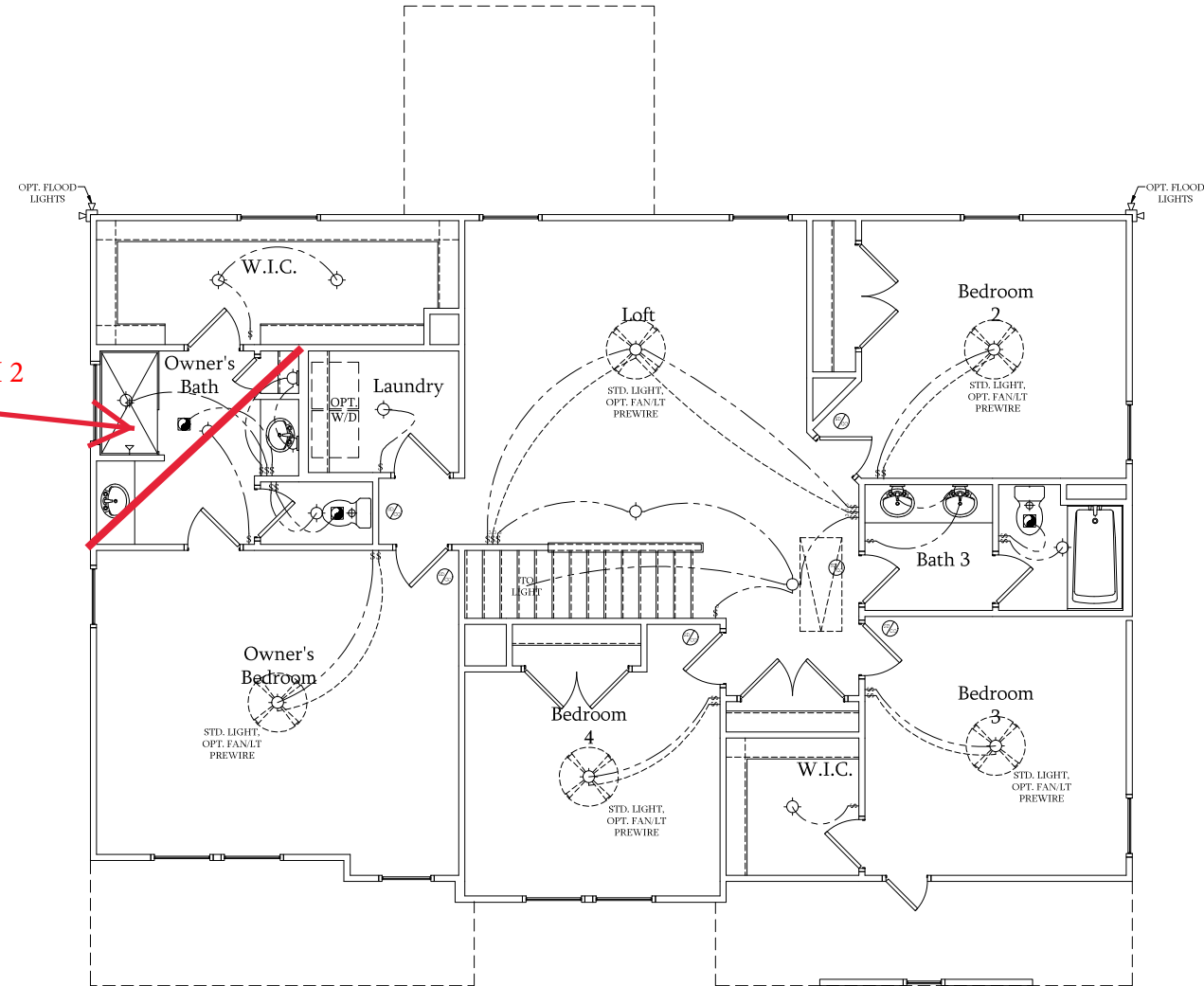

Second Floor Plan

SCALE: 1/4"=1'-0" ON 22x34 AND
1/8"=1'-0" ON 11x17



PRICES, PROMOTIONS, INCENTIVES, FEATURES, MATERIALS, AND DIMENSIONS ARE SUBJECT TO CHANGE WITHOUT NOTICE. SOURCE FOOTAGE AND DIMENSIONS ARE ESTIMATED AND MAY VARY IN ACTUAL CONSTRUCTION. ACTUAL POSITION OF HOUSE ON LOT, VERTICAL CURVES, ELEVATIONS, FINISHES, AND FLOOR PLANS AND ELEVATION DIMENSIONS ARE LATEST CONCEPTIONS. FLOOR PLANS ARE THE COPYRIGHTED PROPERTY OF H&H HOMES. ANY USE, REPRODUCTION, ADAPTATION, OR DERIVATIVE OF THE PLANS IS STRICTLY PROHIBITED. THESE REVISED SALES PLANS ARE FOR CURRENT DETAILS. COPYRIGHT © 2018 H&H HOMES

H&H HOMES, INC
SOUTHPORT

DATE: SEPTEMBER 16, 2019
REV.: AUGUST 01, 2021
SCALE: 1/4"=1'-0"
DRAWN BY:
ENGINEERED BY:
REVIEWED BY:

SECOND FLOOR
ELECTRICAL PLAN

ELECTRICAL LEGEND

- 120V OUTLET
- 120V GFI OUTLET
- 120V SWITCHED OUTLET
- 120V BASEBOARD OUTLET
- 4-PLEX
- FLOOR MOUNTED 120V
- FLOOR MOUNTED 120V GFI
- WEATHERPROOF
- 220V OUTLET
- 120V DEDICATED CIRCUIT
- 220V DEDICATED CIRCUIT
- SPECIAL PURPOSE (240 V, ETC.)
- WALL MOUNT LIGHT
- CEILING MOUNT LIGHT
- PENDANT LIGHT
- RECESSED CAN LIGHT
- MINI CAN LIGHT
- EYEBALL LIGHT
- FLUORESCENT LIGHT
- UNDERCABINET LIGHT
- FLOOD LIGHT
- SWITCH
- 3-WAY SWITCH
- 4-WAY SWITCH
- DIMMER SWITCH
- TELEPHONE
- TV CONNECTION
- CONDUIT FOR COMPONENT WIRING
- SPEAKER
- COMBOSMOKE/
CARBON MONOXIDE DETECTOR
- 110 V SMOKE DETECTOR
- EXHAUST FAN
- LOW VOLTAGE PANEL
- CEILING FAN
- CEILING FAN W/ LIGHT

ELECTRICAL NOTES:

1. PROVIDE AND INSTALL GROUND FAULT CIRCUIT-INTERRUPTERS (G.F.I.) AS INDICATED ON PLANS OR AS ITEM NO. 4 AND 5 BELOW INDICATES.
2. UNLESS OTHERWISE INDICATED, INSTALL SWITCHES AND RECEPTACLES AT THE FOLLOWING HEIGHTS ABOVE FINISHED FLOOR:
SWITCHES... 42"
OUTLETS... 14"
TELEPHONE... 14" (UNLESS ABOVE COUNTERTOP)
TELEVISION... 14"
3. ALL SMOKE DETECTORS SHALL BE HARDWIRED INTO AN ELECTRICAL POWER SOURCE AND SHALL BE EQUIPPED WITH A MONITORED BATTERY BACKUP. PROVIDE AND INSTALL LOCALLY CERTIFIED SMOKE DETECTORS.
4. ALL 15A AND 20A RECEPTACLES IN SLEEPING ROOMS, FAMILY ROOMS, DINING ROOMS, LIVING ROOMS, PARLORS, LIBRARIES, DENS, SUNROOMS, RECREATION ROOMS, CLOSETS, HALLWAYS, AND SIMILAR AREAS WILL REQUIRE A COMBINATION TYPE A.F.C.I. DEVICE AND TAMPER-PROOF RECEPTACLES.
5. ALL 15A AND 20A 120V RECEPTACLES LOCATED IN THE GARAGE AND UTILITY ROOMS SHALL BE G.F.C.I. PROTECTED (G.F.I.).
6. IT IS THE RESPONSIBILITY OF THE LICENSED ELECTRICIAN TO ENSURE THAT ALL ELECTRICAL WORK IS IN FULL COMPLIANCE WITH ALL APPLICABLE LOCAL STANDARDS, CODES, AND ORDINANCES.
7. EVERY BUILDING HAVING A FOSSIL-FUEL-BURNING HEATER OR APPLIANCE, FIREPLACE, OR AN ATTACHED GARAGE SHALL HAVE AN OPERATIONAL CARBON MONOXIDE DETECTOR INSTALLED WITHIN 10 FEET OF EACH ROOM USED FOR SLEEPING PURPOSES.
8. ALARMS SHALL RECEIVE THEIR PRIMARY POWER FROM THE BUILDING WIRING WHEN SUCH WIRING IS SERVED FROM THE LOCAL POWER UTILITY. SUCH ALARMS SHALL HAVE BATTERY BACKUP. COMBINATION SMOKE/CARBON MONOXIDE ALARMS SHALL BE LISTED OR LABELED BY A NATIONALLY RECOGNIZED TESTING LABORATORY.

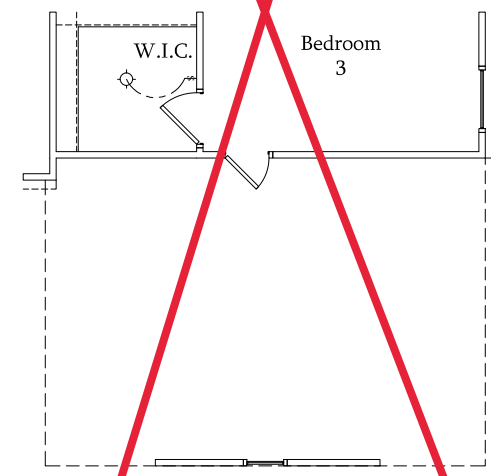
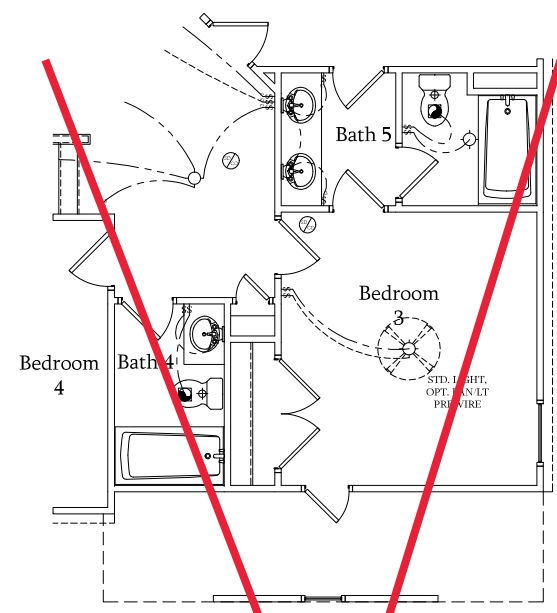
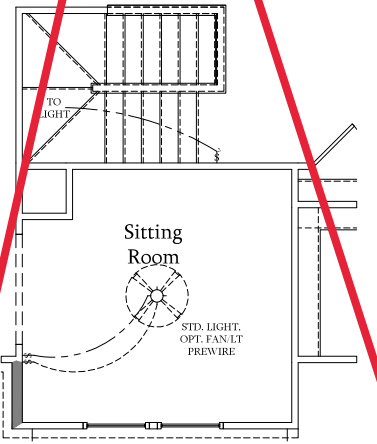
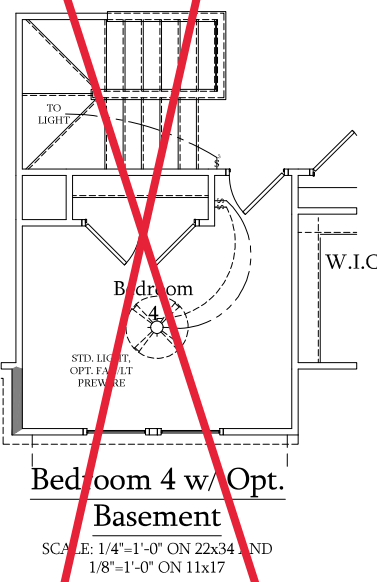
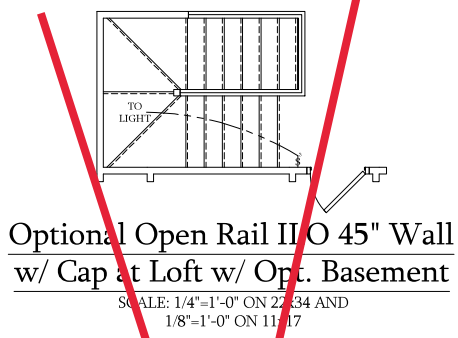
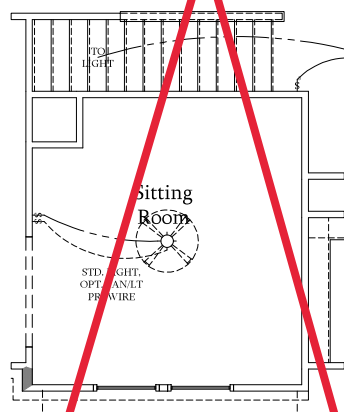
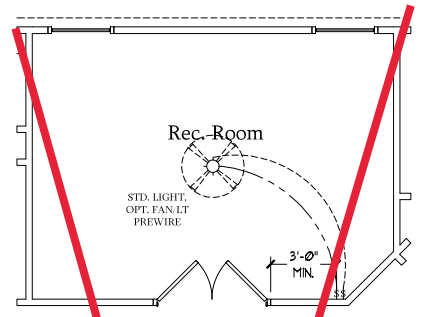
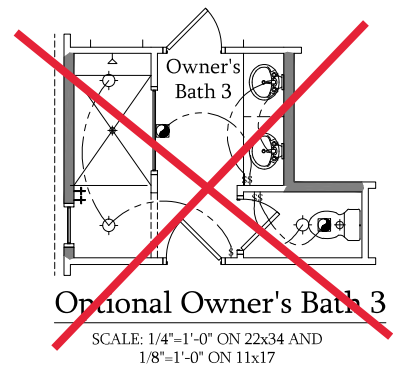
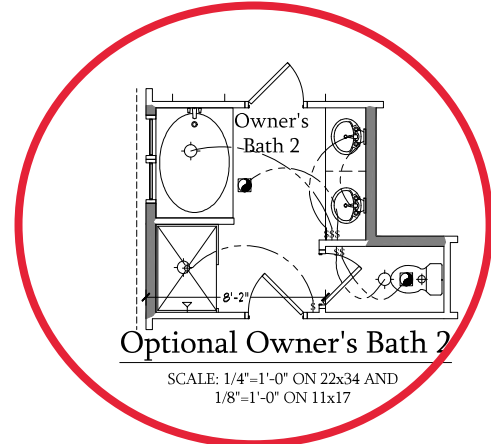

PRICES, PROMOTIONS, INCENTIVES, FEATURES, MATERIALS AND DIMENSIONS ARE SUBJECT TO CHANGE WITHOUT NOTICE. SOURCE FOOTAGE AND DIMENSIONS ARE ESTIMATED AND MAY VARY IN ACTUAL CONSTRUCTION. ACTUAL POSITION OF HOUSE ON LOT, VERTICAL CURVES, ELEVATIONS, FINISHES, AND FLOOR PLANS AND ELEVATIONS ARE ARTIST'S CONCEPTIONS. FLOOR PLANS ARE THE COPYRIGHTED PROPERTY OF H&H HOMES. ANY USE, REPRODUCTION, ADAPTATION, OR DISPLAY OF THE PLANS IS STRICTLY PROHIBITED. REVIEW THESE SALES REPRESENTATIONS FOR CURRENT DETAILS. COPYRIGHT © 2019 H&H HOMES

H&H HOMES, INC
SOUTHPORT

DATE: SEPTEMBER 16, 2019
REV.: AUGUST 01, 2021
SCALE: 1/4"=1'-0"
DRAWN BY:
ENGINEERED BY:
REVIEWED BY:

SECOND FLOOR ELECTRICAL PLAN - OPTIONS

***NOTE: ALL EXTERIOR WALLS AND ATTIC WALLS ARE TO BE 2 x 6 @ 16" O.C. (UNO). 2 x 4 @ 16" O.C. EXTERIOR WALLS MAY BE CONSTRUCTED IN LIEU OF 2 x 6 WALLS (UNO). ALL INTERIOR LOAD BEARING WALLS ARE TO BE 2 x 4 @ 16" O.C. (UNO) AND NON-LOAD BEARING INTERIOR WALLS ARE TO BE 2 x 4 @ 24" O.C. (UNO).**

- BRACED WALL DESIGN NOTES:**
- BRACED WALL DESIGN PER SECTION R602.10 OF THE NIRC 2018 EDITION.
 - CS-UBF REFERS TO 'CONTINUOUS SHEATHING - WOOD STRUCTURAL PANELS' CONTRACTOR IS TO INSTALL 1/16" OSB ON ALL EXTERIOR WALLS ATTACHED w/ 8d NAILS SPACED 6" O.C. ALONG PANEL EDGES AND 12" O.C. IN THE FIELD.
 - GBS REFERS TO 'GYPSUM BOARD' CONTRACTOR IS TO INSTALL 1/2" (MIN.) GYPSUM WALL BOARD WHERE NOTED ON THE PLANS. FASTEN GB WITH 1 1/4" SCREWS OR 1 5/8" NAILS SPACED 12" O.C. ALONG PANEL EDGES AND IN THE FIELD INCLUDING TOP AND BOTTOM PLATES.
 - BRACED WALL DESIGN APPLIED IN WIND ZONES UP TO 150 MPH. FOR HIGH WIND ZONES, BRACE WALLS ARE TO BE CONSTRUCTED IN ACCORDANCE WITH CHAPTER 45 OF THE NIRC 2018 EDITION.
 - SEE NOTES AND DETAIL SHEETS FOR ADDITIONAL BRACED WALL INFORMATION.

BRACED WALL DESIGN

RECTANGLE A		RECTANGLE B	
SIDE 1A (FRONT LOAD)	SIDE 1B	METHOD: CS-UBF/FF	METHOD: FF/CS-UBF
TOTAL REQUIRED LENGTH: 15'	TOTAL REQUIRED LENGTH: 285'	TOTAL REQUIRED LENGTH: 15'	TOTAL REQUIRED LENGTH: 6'
TOTAL PROVIDED LENGTH: 118'	TOTAL PROVIDED LENGTH: 118'	TOTAL PROVIDED LENGTH: 118'	TOTAL PROVIDED LENGTH: 118'
SIDE 2A	SIDE 2B	METHOD: CS-UBF	METHOD: CS-UBF
TOTAL REQUIRED LENGTH: 15'	TOTAL REQUIRED LENGTH: 285'	TOTAL REQUIRED LENGTH: 15'	TOTAL REQUIRED LENGTH: 12'
TOTAL PROVIDED LENGTH: 106'	TOTAL PROVIDED LENGTH: 106'	TOTAL PROVIDED LENGTH: 106'	TOTAL PROVIDED LENGTH: 106'
SIDE 3A	SIDE 3B / SIDE 4A (CUMULATIVE)	METHOD: CS-UBF/GB	METHOD: CS-UBF/GB
TOTAL REQUIRED LENGTH: 16.2'	TOTAL REQUIRED LENGTH: 18.3'	TOTAL REQUIRED LENGTH: 16.2'	TOTAL REQUIRED LENGTH: 21'
TOTAL PROVIDED LENGTH: 20'	TOTAL PROVIDED LENGTH: 21'	TOTAL PROVIDED LENGTH: 20'	TOTAL PROVIDED LENGTH: 21'
SIDE 4B	SIDE 4C	METHOD: CS-UBF/FF	METHOD: CS-UBF
TOTAL REQUIRED LENGTH: 16.2'	TOTAL REQUIRED LENGTH: 21'	TOTAL REQUIRED LENGTH: 16.2'	TOTAL PROVIDED LENGTH: 15.58'

LINTEL SCHEDULE FOR BRICK/NATURAL STONE SUPPORT

LENGTH (FT.)	SIZE OF LINTEL
UP TO 4 FT.	L 3 1/2 x 3 1/2 x 1/4
4-8	L 5 x 3 1/2 x 5/16 LLV
8 AND GREATER	L 6 x 4 x 5/16 LLV

- BRICK SUPPORT NOTES:**
- LINTEL SCHEDULE APPLIES TO ALL OPENINGS IN BRICK VENEER (UNO). SEE ARCH DUGS FOR SIZE AND LOCATION OF OPENINGS.
 - (LLV) = LONG LEG VERTICAL
 - LENGTH = CLEAR OPENING
 - EMBED ALL ANGLE IRONS MIN. 4" EACH SIDE INTO VENEER TO PROVIDE BEARING.
 - FOR ALL HEADERS 8'-0" AND GREATER IN LENGTH, ATTACH STEEL ANGLE TO HEADER w/ 1/2" LAG SCREWS @ 12" O.C. STAGGERED.
 - FOR ALL BRICK SUPPORT @ ROOF LINES, FASTEN (2) 2 x 10 BLOCKING BETWEEN STUDS w/ (4) 2d NAILS PER PLY. FASTEN A 6" x 4" x 5/16" STEEL ANGLE TO (2) 2 x 10 BLOCKING w/ (2) 1/2" LAG SCREWS @ 12" O.C. STAGGERED. SEE SECTION R103.8.21 OF THE 2018 NIRC FOR ADDITIONAL BRICK SUPPORT INFORMATION.
 - PRECAST REINFORCED CONCRETE LINTELS ENGINEERED BY OTHERS MAY BE USED IN LIEU OF STEEL LINTELS.

- STRUCTURAL NOTES:**
- ALL FRAMING LUMBER TO BE SFF #2 (UNO). ALL TREATED LUMBER TO BE SYP #2 (UNO).
 - ALL LOAD BEARING HEADERS TO BE (2) 2 x 6 (UNO).
 - WINDOW AND DOOR HEADERS TO BE SUPPORTED w/ (1) JACK STUD AND (1) KING STUD EA. END (UNO). SEE TABLE R602.15 FOR ADDITIONAL KING STUD REQUIREMENTS.
 - SQUARES DENOTE POINT LOADS WHICH REQUIRE SOLID BLOCKING TO GIRDER OR FOUNDATION. ALL SQUARES TO BE (2) STUDS (UNO).
 - FOR HIGH WIND ZONES, ALL EXTERIOR WALLS TO BE SHEATHED WITH 1/16" OSB SHEATHING WITH JOINTS BLOCKED AND SECURED WITH 8d NAILS AT 3" O.C. ALONG EDGES AND 6" O.C. IN THE FIELD.
 - FOR HIGH WIND ZONES, SECURE ALL EXTERIOR WALL SHEATHING PANELS TO DOUBLE TOP PLATES, BANDS, JOISTS AND GIRDERS WITH (2) ROWS OF 8d NAILS STAGGERED AT 3" O.C. PANELS SHALL EXTEND 12" BEYOND CONSTRUCTION JOINTS AND SHALL OVERLAP GIRDERS AND DOUBLE SILL PLATES THEIR FULL DEPTH.
 - ALL 4 x 4 POSTS SHALL BE ANCHORED TO SLABS w/ SIMPSON ABU44 POST BASES (OR EQUAL) AND 6 x 6 POSTS w/ ABU66 POST BASES (OR EQUAL) (UNO). ALL 4 x 4 AND 6 x 6 POSTS TO BE INSTALLED WITH 1000 LB CAPACITY UPLIFT CONNECTORS AT TOP (UNO).
 - FOR FIBERGLASS, ALUMINUM, OR COLUMN ENG. BY OTHERS, SECURE TO SLAB w/ (2) METAL ANGLES USING 2" CONC. SCREWS. FASTEN ANGLES TO COLUMNS w/ 1/4" THROUGH BOLTS w/ NUTS AND WASHERS. LOCATE ANGLES ON OPPOSITE SIDES OF COLUMN. THROUGH BOLTS MUST BE INSTALLED PRIOR TO SETTING COLUMN.
 - REFER TO NOTES AND DETAIL SHEETS FOR ADDITIONAL STRUCTURAL INFORMATION.

TABLE R602.15
MINIMUM NUMBER OF FULL HEIGHT STUDS AT EACH END OF HEADERS IN EXTERIOR WALLS (PER TABLE R602.15)

HEADER SPAN (FEET)	MAXIMUM STUD SPACING (INCHES)	
	16	24
UP TO 3'	1	1
4'	2	1
8'	3	2
12'	5	3
16'	6	4

J.S. THOMPSON ENGINEERING, INC
606 WADE AVE., SUITE 104 RALEIGH, NC 27605
PHONE: (919) 789-9919 FAX: (919) 789-9921
N.C. LICENSE NO.: C-1735

SOUTHPORT H&H HOMES

DATE: NOVEMBER 2, 2021
SCALE: 1/4" = 1'-0"
DRAWN BY: H&H HOMES
ENGINEERED BY: WFB

SHEET: 6 OF 9
S-3
SECOND FLOOR FRAMING PLAN

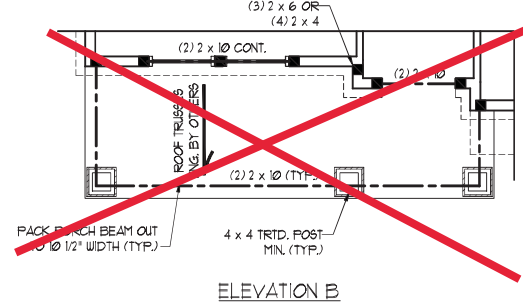
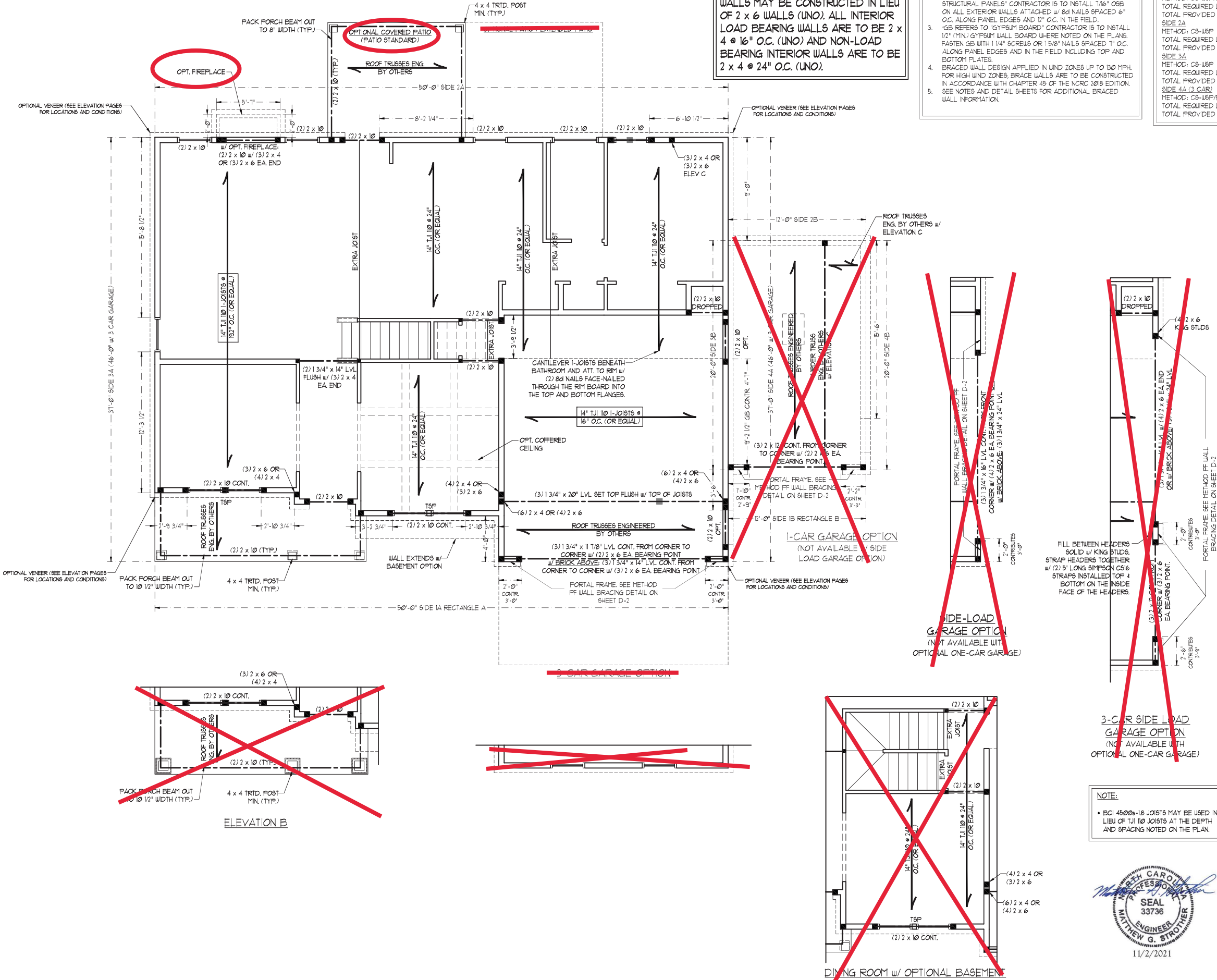

NOTE:
• BCI 4500s-18 JOISTS MAY BE USED IN LIEU OF TJI 110 JOISTS AT THE DEPTH AND SPACING NOTED ON THE PLAN.



11/2/2021

***NOTE: ALL EXTERIOR WALLS AND ATTIC WALLS ARE TO BE 2 x 6 @ 16" O.C. (UNO). 2 x 4 @ 16" O.C. EXTERIOR WALLS MAY BE CONSTRUCTED IN LIEU OF 2 x 6 WALLS (UNO). ALL INTERIOR LOAD BEARING WALLS ARE TO BE 2 x 4 @ 16" O.C. (UNO) AND NON-LOAD BEARING INTERIOR WALLS ARE TO BE 2 x 4 @ 24" O.C. (UNO).**

- BRACED WALL DESIGN NOTES:**
- BRACED WALL DESIGN PER SECTION R602.10 OF THE NRC 2018 EDITION.
 - C5-W6P REFERS TO "CONTINUOUS SHEATHING - WOOD STRUCTURAL PANELS" CONTRACTOR IS TO INSTALL 1/8" OSB ON ALL EXTERIOR WALLS ATTACHED w/ 8d NAILS SPACED 6" O.C. ALONG PANEL EDGES AND 12" O.C. IN THE FIELD.
 - GB REFERS TO "GYPSUM BOARD" CONTRACTOR IS TO INSTALL 1/2" (MIN.) GYPSUM WALL BOARD WHERE NOTED ON THE PLANS. FASTEN GB WITH 1 1/4" SCREWS OR 1 5/8" NAILS SPACED 12" O.C. ALONG PANEL EDGES AND IN THE FIELD INCLUDING TOP AND BOTTOM PLATES.
 - BRACED WALL DESIGN APPLIED IN WIND ZONES UP TO 130 MPH. FOR HIGH WIND ZONES, BRACE WALLS ARE TO BE CONSTRUCTED IN ACCORDANCE WITH CHAPTER 45 OF THE NRC 2018 EDITION.
 - SEE NOTES AND DETAIL SHEETS FOR ADDITIONAL BRACED WALL INFORMATION.

- NOTE:**
- PER SECTION R602.10.3.2 OF THE 2018 NRC, THE AMOUNT OF BRACING ON THE SECOND FLOOR EXCEEDS THE AMOUNT REQUIRED FOR THE FIRST FLOOR AND NO BRACED WALL ANALYSIS IS REQUIRED.
 - SHEATH ALL EXTERIOR WALLS WITH 1/8" OSB SHEATHING ATTACHED WITH 8d NAILS AT 6" O.C. ALONG PANEL EDGES AND 12" O.C. IN THE FIELD.

LINTEL SCHEDULE FOR BRICK/NATURAL STONE SUPPORT

LENGTH (FT.)	SIZE OF LINTEL
UP TO 4 FT.	L 3 1/2 x 3 1/2 x 1/4
4-8	L 5 x 3 1/2 x 5/16 LLV
8 AND GREATER	L 6 x 4 x 5/16 LLV

- BRICK SUPPORT NOTES:**
- LINTEL SCHEDULE APPLIES TO ALL OPENINGS IN BRICK VENEER (UNO). SEE ARCH DIAGS. FOR SIZE AND LOCATION OF OPENINGS.
 - (LLV) = LONG LEG VERTICAL
 - LENGTH = CLEAR OPENING
 - EMBED ALL ANGLE IRONS MIN. 4" EACH SIDE INTO VENEER TO PROVIDE BEARING.
 - FOR ALL HEADERS 8"-12" AND GREATER IN LENGTH, ATTACH STEEL ANGLE TO HEADER w/ 1/2" LAG SCREWS @ 12" O.C. STAGGERED.
 - FOR ALL BRICK SUPPORT @ ROOF LINES, FASTEN (2) 2 x 10 BLOCKING BETWEEN STUDS w/ (4) 2d NAILS PER FLY. FASTEN A 6" x 4" x 5/16" STEEL ANGLE TO (2) 2 x 10 BLOCKING w/ (2) 1/2" LAG SCREWS @ 12" O.C. STAGGERED. (SEE SECTION R103.5.2) OF THE 2018 NRC FOR ADDITIONAL BRICK SUPPORT INFORMATION.
 - PRECAST REINFORCED CONCRETE LINTELS ENGINEERED BY OTHERS MAY BE USED IN LIEU OF STEEL LINTELS.

- STRUCTURAL NOTES:**
- ALL FRAMING LUMBER TO BE SFF 1/2 (UNO). ALL TREATED LUMBER TO BE SYP 1/2 (UNO).
 - ALL LOAD BEARING HEADERS TO BE (2) 2 x 6 (UNO).
 - WINDOW AND DOOR HEADERS TO BE SUPPORTED w/ (1) JACK STUD AND (1) KING STUD EA. END (UNO). SEE TABLE R602.15 FOR ADDITIONAL KING STUD REQUIREMENTS.
 - SQUARES DENOTE POINT LOADS WHICH REQUIRE SOLID BLOCKING TO GIRDER OR FOUNDATION. ALL SQUARES TO BE (2) STUDS (UNO).
 - FOR HIGH WIND ZONES, ALL EXTERIOR WALLS TO BE SHEATHED WITH 1/8" OSB SHEATHING WITH JOINTS BLOCKED AND SECURED WITH 8d NAILS AT 3" O.C. ALONG EDGES AND 6" O.C. IN THE FIELD.
 - FOR HIGH WIND ZONES, SECURE ALL EXTERIOR WALL SHEATHING PANELS TO DOUBLE TOP PLATES, BANDS, JOISTS, AND GIRDERS WITH (2) ROWS OF 8d NAILS STAGGERED AT 3" O.C. PANELS SHALL EXTEND 12" BEYOND CONSTRUCTION JOINTS AND SHALL OVERLAP GIRDERS AND DOUBLE SILL PLATES THEIR FULL DEPTH. REFER TO NOTES AND DETAIL SHEETS FOR ADDITIONAL STRUCTURAL INFORMATION.

TABLE R602.15
MINIMUM NUMBER OF FULL HEIGHT STUDS AT EACH END OF HEADERS IN EXTERIOR WALLS

HEADER SPAN (FEET)	MAXIMUM STUD SPACING (INCHES) (PER TABLE R602.3/5)	
	16	24
UP TO 3'	1	1
4'	2	1
8'	3	2
12'	5	3
16'	6	4

J.S. THOMPSON ENGINEERING, INC
606 WADE AVE., SUITE 104 RALEIGH, NC 27605
PHONE: (919) 789-9919 FAX: (919) 789-9921
N.C. LICENSE NO.: C-1733

SOUTHPORT H&H HOMES

DATE: NOVEMBER 2, 2021
SCALE: 1/4" = 1'-0"
DRAWN BY: H&H HOMES
ENGINEERED BY: WFB

SHEET: 7 OF 9
S4
CEILING FRAMING PLAN

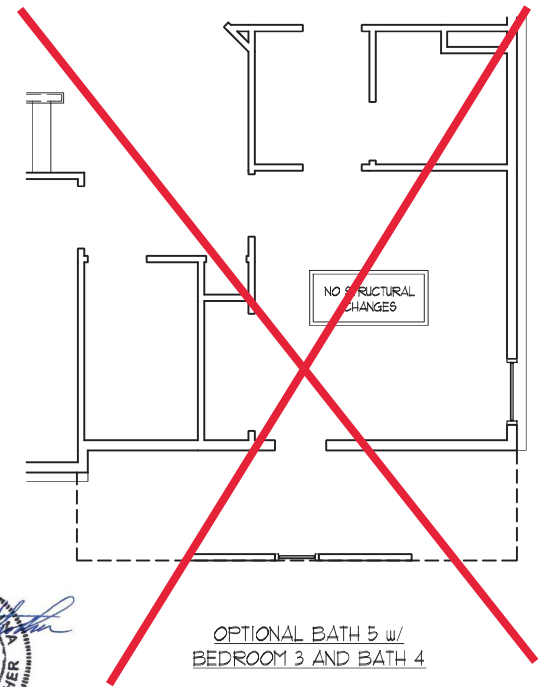
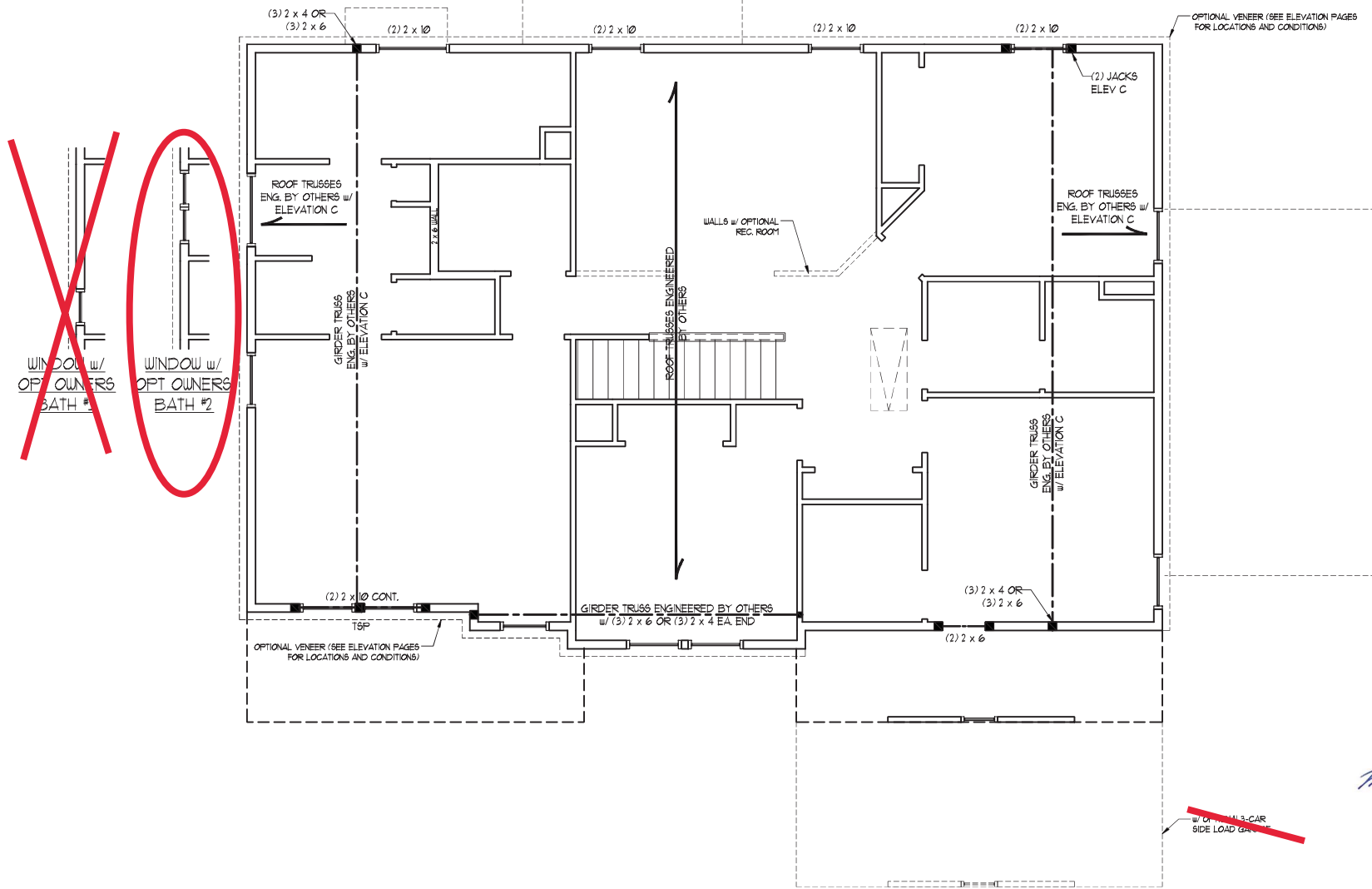

SEAL
33736
ENGINEER
MATTHEW G. STROTHER
11/2/2021

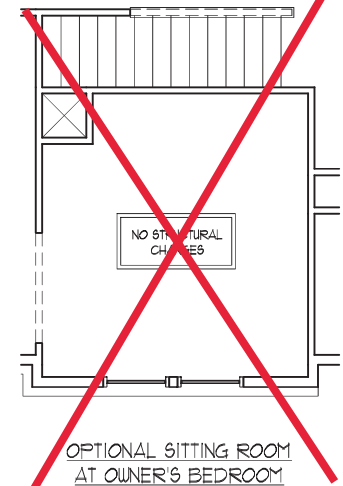
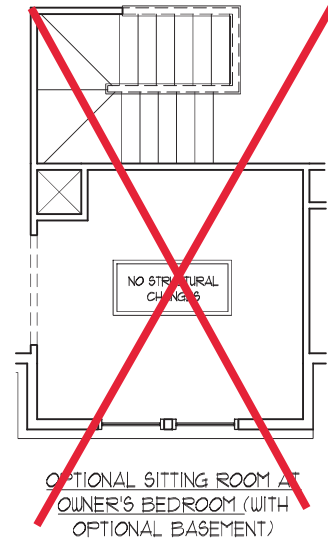
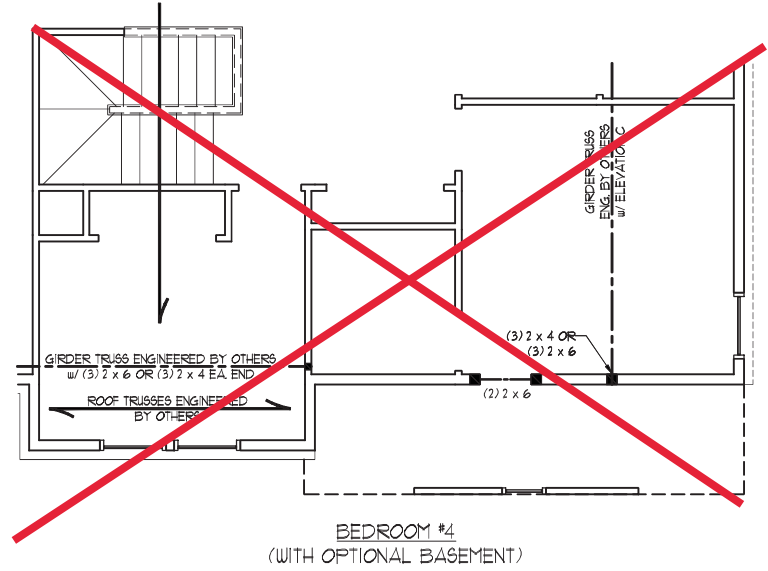

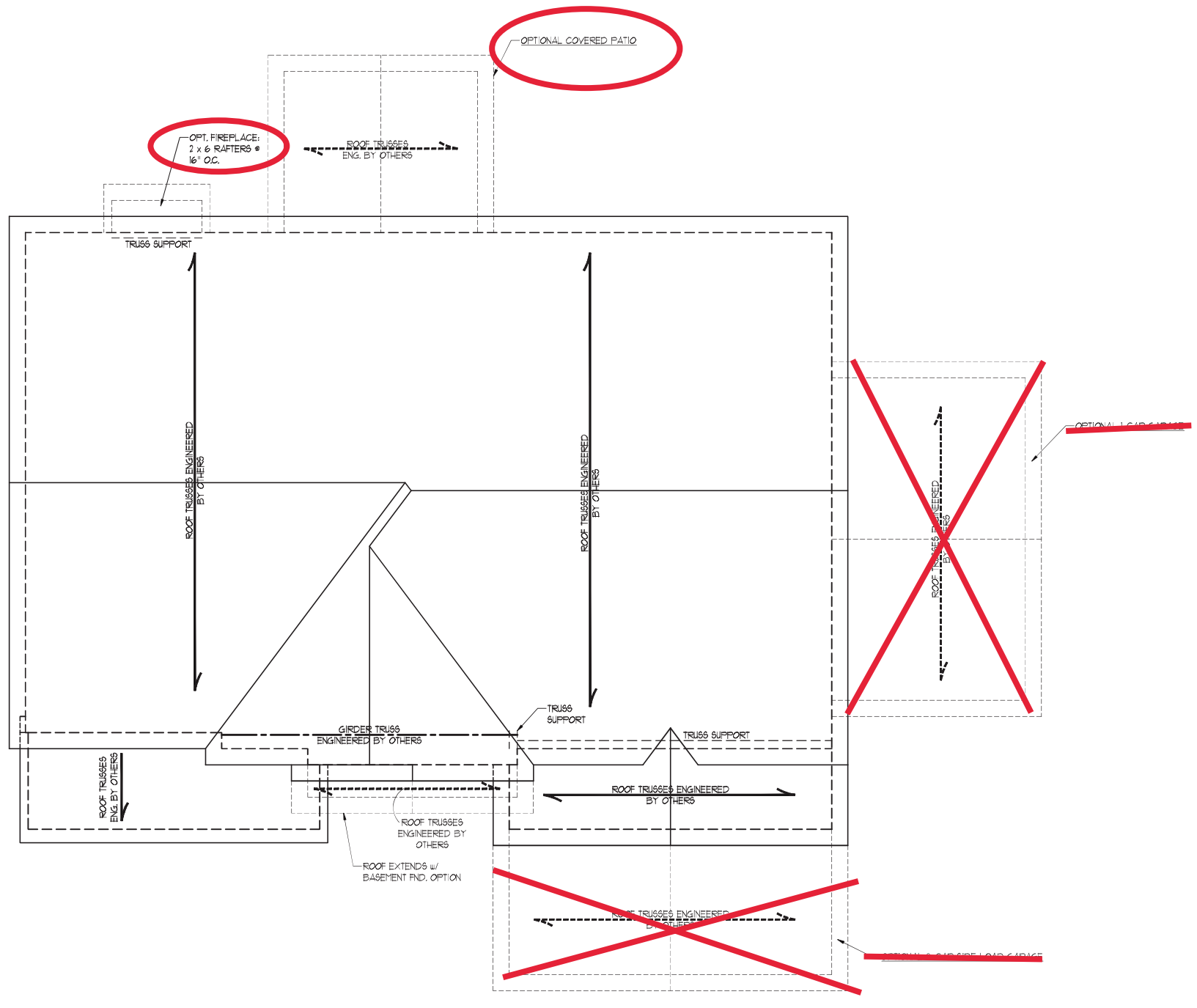

ELEVATIONS A & B

BRICK SUPPORT NOTE:

1. FASTEN (2) 2 x 10 BLOCKING BETWEEN WALL STUDS w/ (4) 12d NAILS PER FLY. FASTEN A 6" x 4" x 5/16" STEEL ANGLE TO (2) 2 x 10 BLOCKING w/ (2) 1/2" LAG SCREWS @ 12" O.C. STAGGERED. SEE SECTION R103.821. OF THE 2018 NRC FOR ADDITIONAL BRICK SUPPORT INFORMATION.
2. WHERE ROOF SLOPES EXCEED 1:12, INSTALL 3" x 3" x 1/4" STEEL PLATE STOPS AT 24" O.C. PER SECTION R103.821 OF THE NORTH CAROLINA RESIDENTIAL CODE, 2018 EDITION.

STRUCTURAL NOTES:

1. ALL FRAMING LUMBER TO BE #2 SPF (UND).
2. CIRCLES DENOTE (3) 2 x 4 POSTS FOR ROOF SUPPORT.
3. FRAME DORMER WALLS ON TOP OF DOUBLE OR TRIPLE RAFTERS.
4. HIP SPLICES ARE TO BE SPACED A MIN. OF 8'-0". FASTEN MEMBERS WITH THREE ROWS OF 12d NAILS @ 16" O.C. (TYP)
5. STICK FRAME OVER-FRAMED ROOF SECTIONS w/ 2 x 8 RIDGES, 2 x 6 RAFTERS @ 16" O.C. AND FLAT 2 x 10 VALLEYS OR USE VALLEY TRUSSES.
6. FASTEN FLAT VALLEYS TO RAFTERS OR TRUSSES WITH SIMPSON H2.5A HURRICANE TIES @ 32" O.C. MAX. PASS HURRICANE TIES THROUGH NOTCH IN ROOF SHEATHING. EACH RAFTER IS TO BE FASTENED TO THE FLAT VALLEY WITH A MIN. OF (6) 12d TOE NAILS.
7. REFER TO SECTION R202.11 OF THE 2018 NRC FOR REQUIRED UPLIFT RESISTANCE AT RAFTERS AND TRUSSES.
8. REFER TO NOTES AND DETAIL SHEETS FOR ADDITIONAL STRUCTURAL INFORMATION.

J.S. THOMPSON ENGINEERING, INC
 606 WADE AVE., SUITE 104 RALEIGH, NC 27605
 PHONE: (919) 789-9919 FAX: (919) 789-9921
 N.C. LICENSE NO.: C-1733

SOUTHPORT H&H HOMES

DATE: NOVEMBER 2, 2021
SCALE: 1/4" = 1'-0"
DRAWN BY: H&H HOMES
ENGINEERED BY: WFB

SHEET: 8 OF 9
S-5a
 ROOF FRAMING PLAN

11/2/2021

MONOLITHIC SLAB DETAILS

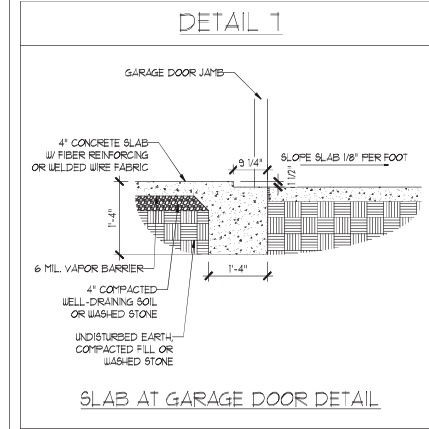
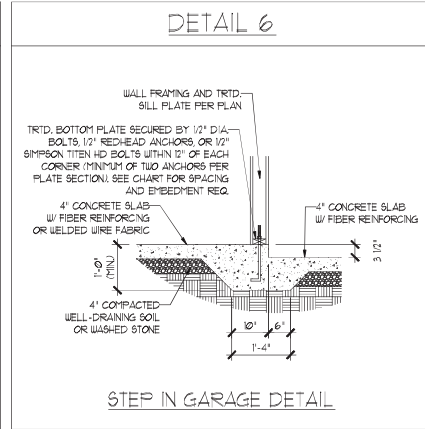
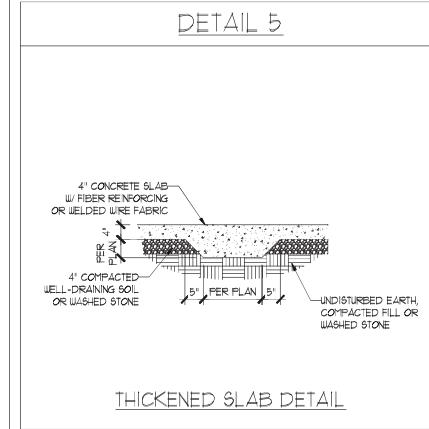
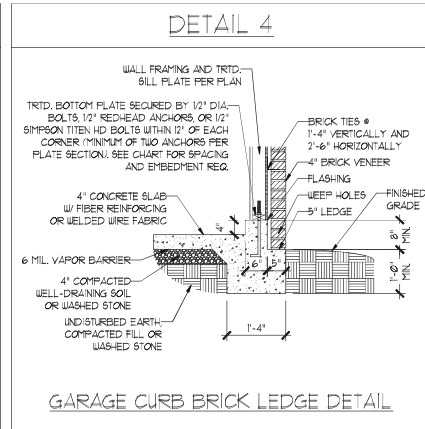
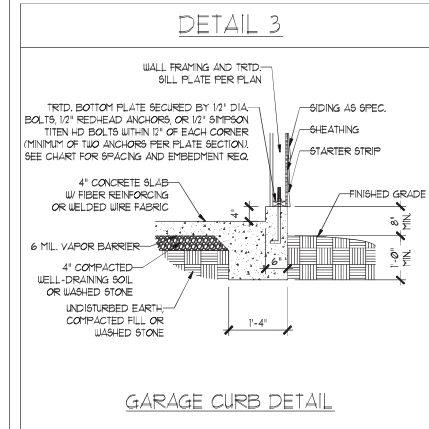
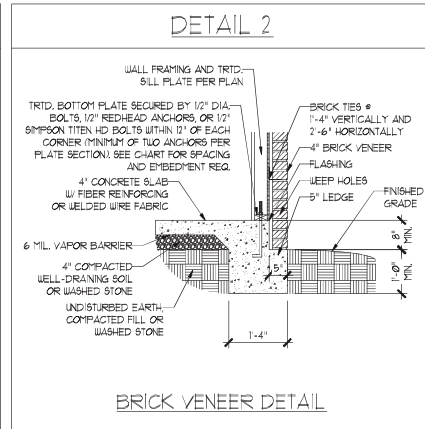
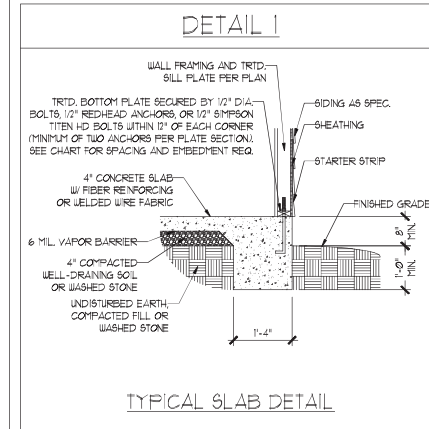

STEMWALL DETAILS

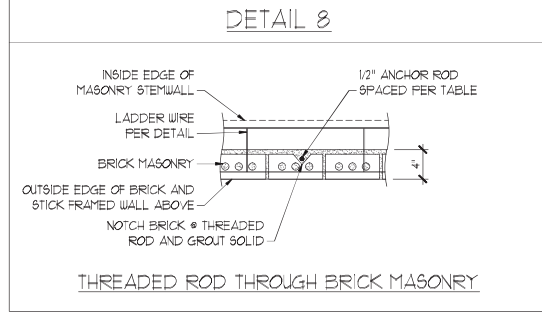
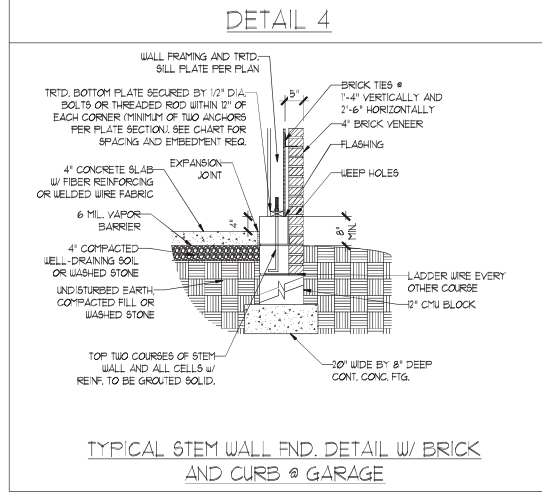
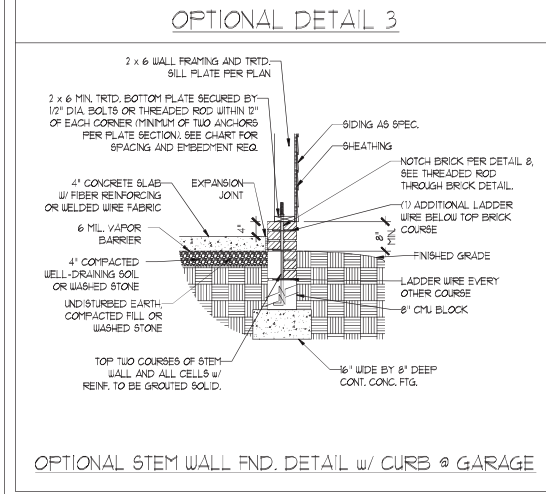
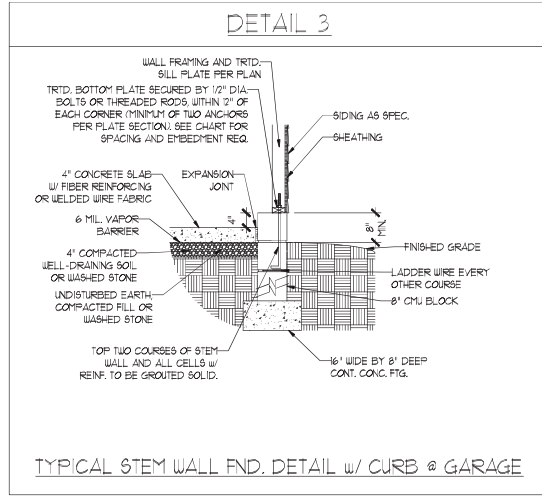
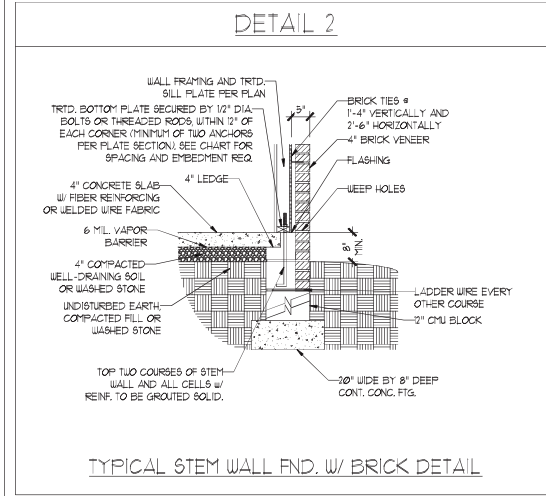
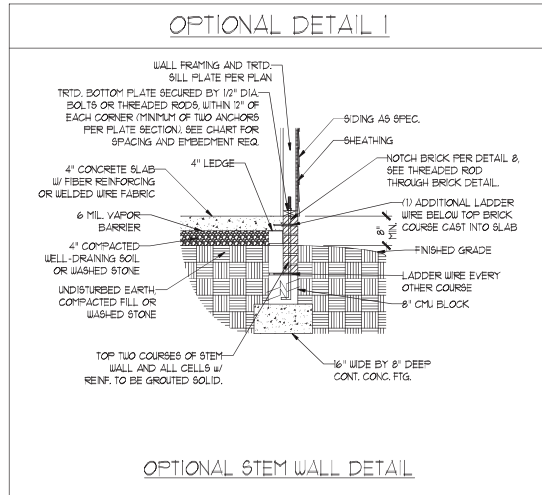
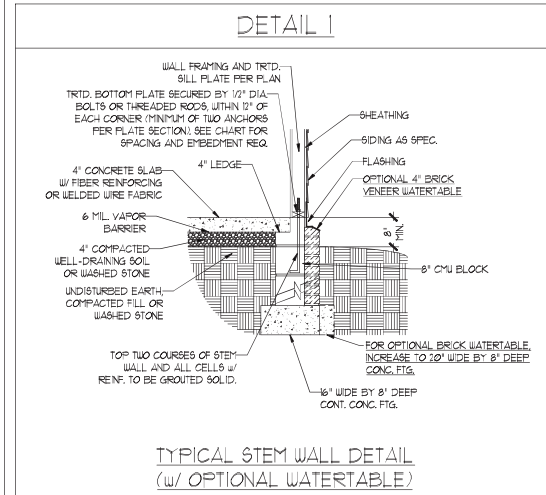

MASONRY STEMWALL SPECIFICATIONS

WALL HEIGHT (FEET)	MASONRY WALL TYPE			
	8" CMU	4" BRICK AND 4" CMU	4" BRICK AND 8" CMU	12" CMU
2 AND BELOW	UNGROUTED	GROUT SOLID	UNGROUTED	UNGROUTED
3	UNGROUTED	GROUT SOLID	UNGROUTED	UNGROUTED
4	GROUT SOLID	GROUT SOLID w/ #4 REBAR @ 48" O.C.	GROUT SOLID	GROUT SOLID w/ #4 REBAR @ 64" O.C.
5	GROUT SOLID w/ #4 REBAR @ 36" O.C.	NOT APPLICABLE	GROUT SOLID w/ #4 REBAR @ 36" O.C.	GROUT SOLID w/ #4 REBAR @ 64" O.C.
6	GROUT SOLID w/ #4 REBAR @ 24" O.C.	NOT APPLICABLE	GROUT SOLID w/ #4 REBAR @ 24" O.C.	GROUT SOLID w/ #4 REBAR @ 64" O.C.
7 AND GREATER	ENGINEERED DESIGN BASED ON SITE CONDITIONS			

STRUCTURAL NOTES:

- WALL HEIGHT MEASURED FROM TOP OF FOOTING TO TOP OF THE WALL.
- TIE MULTIPLE WLTTHES TOGETHER WITH LADDER WIRE AT 16" O.C. VERTICALLY.
- CHART APPLICABLE FOR HOUSE FOUNDATION ONLY. CONSULT ENGINEER FOR DESIGN OF GARAGE FOUNDATION NOT COMMON TO HOUSE.
- BACKFILL OF CLEAN #57 / #61 WASHED STONE IS ALLOWABLE.
- BACKFILL OF WELL DRAINED OR SAND - GRAVEL MIXTURE SOILS (45 PSF/FT BELOW GRADE) CLASSIFIED AS GROUP 1 ACCORDING TO UNIFIED SOILS CLASSIFICATION SYSTEM IN ACCORDANCE WITH TABLE R405.1 OF THE 2018 INTERNATIONAL RESIDENTIAL CODE ARE ALLOWABLE.
- PREP SLAB PER R502.2.1 AND R502.2.2 BASE OF THE 2018 INTERNATIONAL RESIDENTIAL CODE. MINIMUM 24" LAP SPLICE LENGTH.
- LOCATE REBAR IN CENTER OF FOUNDATION WALL.
- WHERE REQUIRED, FILL BLOCK SOLID WITH TYPE "S" MORTAR OR 3000 PSI GROUT. USE OF "LOW LIFT GROUTING" METHOD REQUIRED WHEN FILLING WALLS WITH GROUT AT HEIGHTS OF 5' AND GREATER.

ANCHOR SPACING AND EMBEDMENT

WIND ZONE	120 MPH	130 MPH
SPACING	6'-0" O.C.	4'-0" O.C.
EMBEDMENT	1'	15" INTO MASONRY 1" INTO CONCRETE

J.S. THOMPSON ENGINEERING, INC.
600 WADE AVE., SUITE 104 RALEIGH, NC 27605
PHONE: (919) 789-9919 FAX: (919) 789-9921
N.C. LICENSE NO.: C-1733

120 MPH - 130 MPH ULTIMATE DESIGN WIND SPEED
FOUNDATION DETAILS

DATE: NOVEMBER 14, 2018
SCALE: NTS
DRAWN BY: JST
ENGINEERED BY: JES

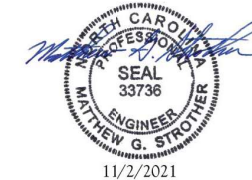

D-1
FOUNDATION DETAILS

GENERAL WALL BRACING NOTES:

1. WALL BRACING DESIGNED IN ACCORDANCE WITH CHAPTER 6 OF THE 2018 NC RESIDENTIAL BUILDING CODE (NCRBC). TABLES AND FIGURES REFERENCED ARE FROM THE 2018 NCRBC.
2. SEE THIS SHEET FOR GENERAL DETAILS. REFER TO THE 2018 NCRBC FOR ADDITIONAL INFORMATION AS NEEDED.
3. SEE STRUCTURAL SHEETS FOR BRACED WALL LOCATIONS, DIMENSIONS, HOLD DOWN TYPE AND LOCATIONS, BRACED WALL LINE KEY WITH WALL DESIGN SUMMARY OF REQUIRED/PROVIDED TOTALS FOR EACH WALL LINE AND ANY SPECIAL NOTES OR REQUIREMENTS.
4. ALL EXTERIOR WALLS ARE TO BE SHEATHED WITH CS-USP IN ACCORDANCE WITH SECTION R602.10.3 UNLESS NOTED OTHERWISE.
5. ALL EXTERIOR AND INTERIOR WALLS TO HAVE 1/2" GYPSUM INSTALLED. WHEN NOT USING METHOD 'GB', GYPSUM TO BE FASTENED PER TABLE R102.3.5. METHOD GB TO BE FASTENED PER TABLE R602.10.1.
6. CS-USP REFERS TO THE 'CONTINUOUS SHEATHING - WOOD STRUCTURAL PANELS' WALL BRACING METHOD. 1/16" OSB SHEATHING IS TO BE INSTALLED ON ALL EXTERIOR WALLS ATTACHED w/ 6d COMMON NAILS OR 8d (2 1/2" LONG x 0.13" DIAMETER) NAILS SPACED 6" O.C. ALONG PANEL EDGES AND 12" O.C. IN THE FIELD (UNO).
7. GB REFERS TO THE 'GYPSUM BOARD' WALL BRACING METHOD. 1/2" (MIN.) GYPSUM WALL BOARD IS TO BE INSTALLED ON BOTH SIDES OF THE BRACED WALL FASTENED WITH 1 1/4" SCREWS OR 1 5/8" NAILS SPACED 1' O.C. ALONG PANEL EDGES INCLUDING TOP AND BOTTOM FLATES AND INTERMEDIATE SUPPORTS (UNO). VERIFY ALL FASTENER OPTIONS FOR 1/2" AND 5/8" GYPSUM PRIOR TO CONSTRUCTION. FOR INTERIOR FASTENER OPTIONS SEE TABLE R102.3.5. FOR EXTERIOR FASTENER OPTIONS SEE TABLE R602.3(1). EXTERIOR GB TO BE INSTALLED VERTICALLY.
8. REQUIRED BRACED WALL LENGTH FOR EACH SIDE OF THE CIRCUMSCRIBED RECTANGLE ARE INTERPOLATED PER TABLE R602.10.3. METHOD CS-USP CONTRIBUTES ITS ACTUAL LENGTH, METHOD GB CONTRIBUTES 5 ITS ACTUAL LENGTH, AND METHOD PF CONTRIBUTES 15 TIMES ITS ACTUAL LENGTH.

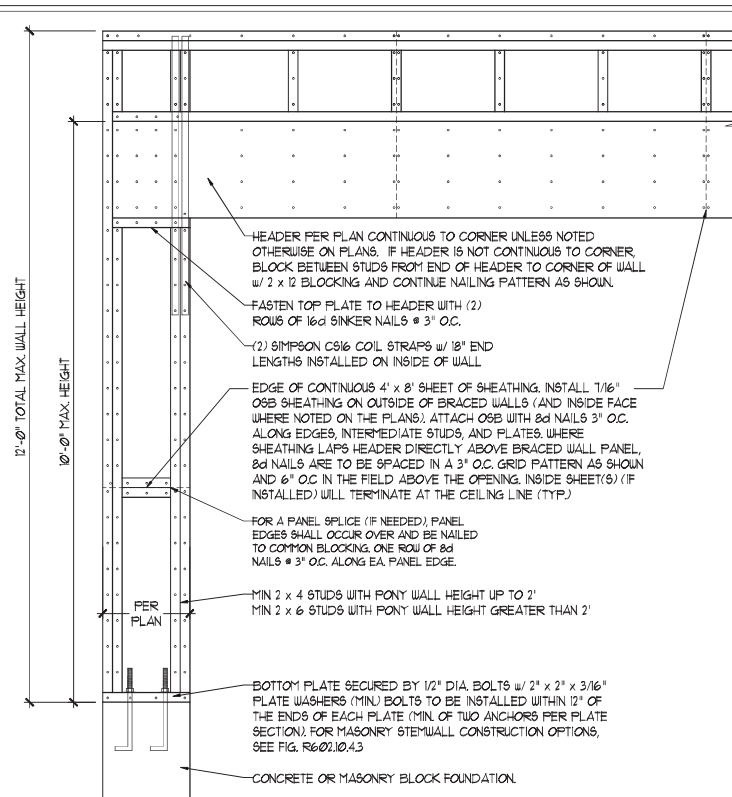

OVER CONCRETE OR MASONRY BLOCK FOUNDATION

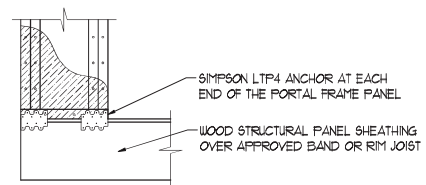

OVER RAISED WOOD FLOOR - FRAMING ANCHOR OPTION
 * APPLICABLE w/ GREATER THAN 12" KNEE WALL HEIGHTS IN CRAWL SPACE AND ABOVE FRAMED BASEMENT WALLS *

METHOD PF-PORTAL FRAME DETAIL ①

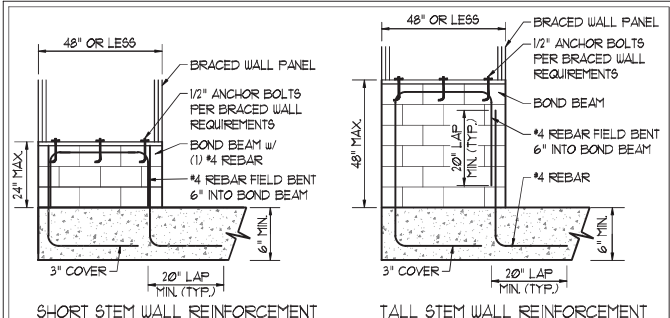

SHORT STEM WALL REINFORCEMENT

TALL STEM WALL REINFORCEMENT

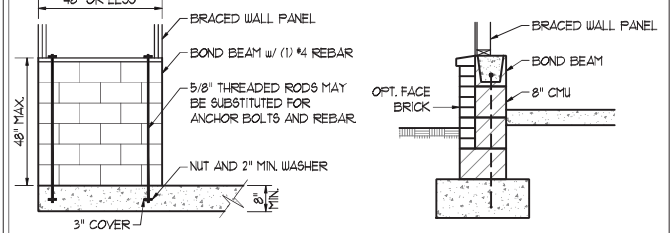

TYPICAL STEM WALL SECTION

RODS MAY BE INSTALLED USING AN ADHESIVE ANCHORING SYSTEM WITH A MINIMUM TENSILE CAPACITY OF 3750 LBS AND INSTALLED IN ACCORDANCE WITH MANUFACTURER'S SPECS.

OPTIONAL STEM WALL REINFORCEMENT

NOTE: GROUT BOND BEAMS AND ALL CELLS WHICH CONTAIN REBAR, THREADED RODS AND ANCHOR BOLTS

MASONRY STEM WALLS SUPPORTING BRACED WALL PANELS ②

PER FIGURE R602.10.4.3

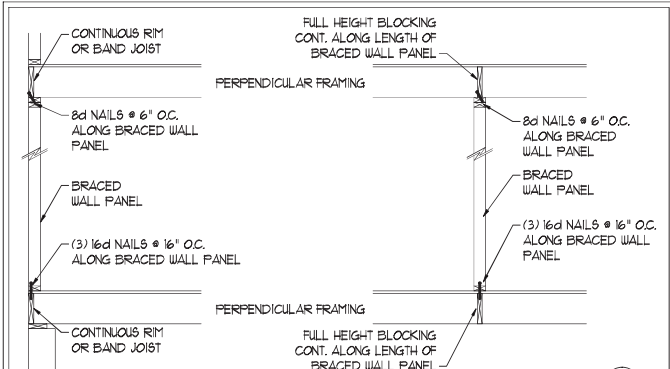

BRACED WALL PANEL CONNECTION WHEN PERPENDICULAR TO FLOOR/CEILING FRAMING ③

PER FIGURE R602.10.4.4(1)

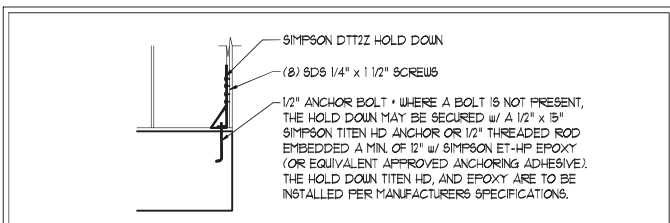

HOLD DOWN DETAIL FOR MASONRY FOUNDATION OR MONOLITHIC SLAB ④

* APPLICABLE ONLY WHERE SPECIFIED ON PLAN *

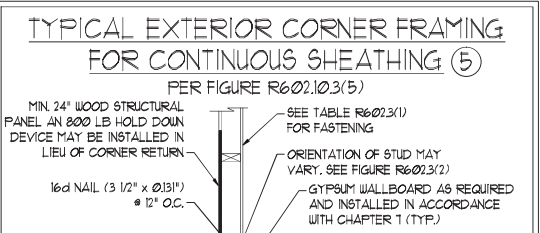

(a) OUTSIDE CORNER DETAIL 5a

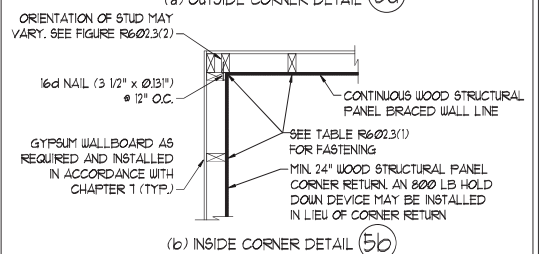

(b) INSIDE CORNER DETAIL 5b

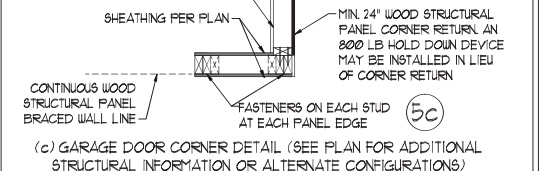

(c) GARAGE DOOR CORNER DETAIL (SEE PLAN FOR ADDITIONAL STRUCTURAL INFORMATION OR ALTERNATE CONFIGURATIONS)

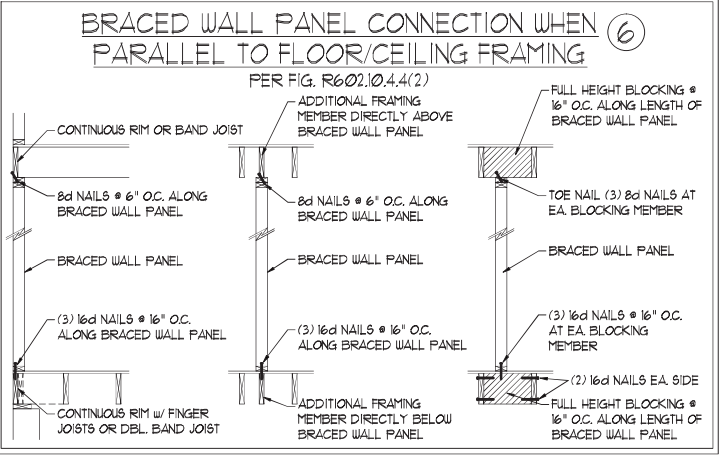

BRACED WALL PANEL CONNECTION WHEN PARALLEL TO FLOOR/CEILING FRAMING ⑥

PER FIG. R602.10.4.4(2)

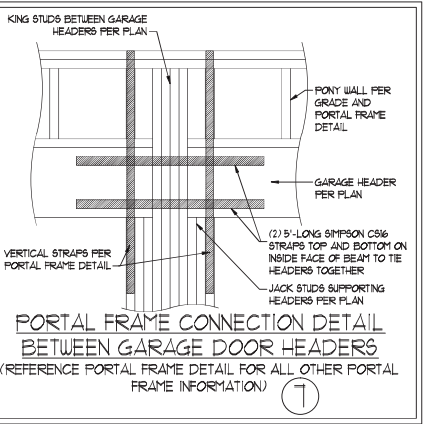

PORTAL FRAME CONNECTION DETAIL BETWEEN GARAGE DOOR HEADERS (REFERENCE PORTAL FRAME DETAIL FOR ALL OTHER PORTAL FRAME INFORMATION) ⑦

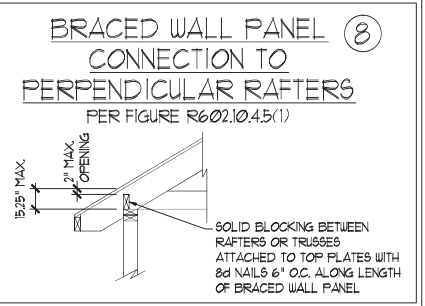

BRACED WALL PANEL CONNECTION TO PERPENDICULAR RAFTERS ⑧

PER FIGURE R602.10.4.5(1)

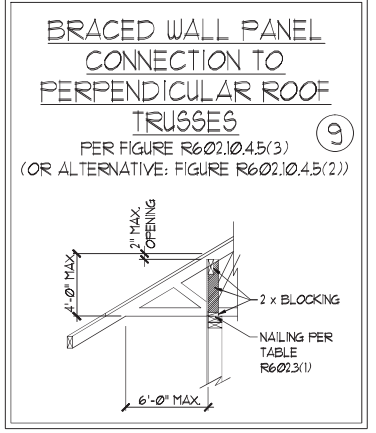

BRACED WALL PANEL CONNECTION TO PERPENDICULAR ROOF TRUSSES ⑨

PER FIGURE R602.10.4.5(3) (OR ALTERNATIVE: FIGURE R602.10.4.5(2))

This sealed page is to be used in conjunction with a full plan set engineered by J.S. Thompson Engineering, Inc. only. Use of this individual sealed page within architectural pages or shop drawings by others is a punishable offense under N.C. Statute § 89C-23



11/2/2021

J.S. THOMPSON ENGINEERING, INC.
 606 WADE AVE., SUITE 104 RALEIGH, NC 27605
 PHONE: (919) 789-9919 FAX: (919) 789-9921
 N.C. LICENSE NO.: C-1733

120 MPH - 130 MPH ULTIMATE DESIGN WIND SPEED
 WALL BRACING NOTES AND DETAILS

DATE: NOVEMBER 14, 2018
 SCALE: 1/4" = 1'-0"
 DRAWN BY: JST
 ENGINEERED BY: JST

D-2
 BRACED WALL NOTES AND DETAILS AND PF DETAIL

GENERAL NOTES

- ENGINEER'S SEAL APPLIES ONLY TO STRUCTURAL COMPONENTS INCLUDING ROOF RAFTERS, HIPS, VALLEYS, RIDGES, FLOORS, WALLS, BEAMS, HEADERS, COLUMNS, CANTILEVERS, OFFSET LOAD BEARING WALLS, PIERS, GIRDER SYSTEM AND FOOTING. ENGINEER'S SEAL DOES NOT CERTIFY DIMENSIONAL ACCURACY OF ARCHITECTURAL LAYOUT INCLUDING ROOF. ENGINEER'S SEAL DOES NOT APPLY TO I-JOIST OR FLOOR/ROOF TRUSS LAYOUT DESIGN AND ACCURACY.
 - ALL CONSTRUCTION SHALL CONFORM TO THE LATEST REQUIREMENTS OF THE NORTH CAROLINA RESIDENTIAL CODE (NRC), 2018 EDITION, PLUS ALL LOCAL CODES AND REGULATIONS. THE STRUCTURAL ENGINEER IS NOT RESPONSIBLE FOR, AND WILL NOT HAVE CONTROL OF, CONSTRUCTION MEANS, METHODS, TECHNIQUES, SEQUENCES OR PROCEDURES, OR SAFETY PRECAUTIONS AND PROGRAMS IN CONNECTION WITH THE CONSTRUCTION WORK. NOR WILL THE ENGINEER BE RESPONSIBLE FOR THE CONTRACTOR'S FAILURE TO CARRY OUT THE CONSTRUCTION WORK IN ACCORDANCE WITH THE CONTRACT DOCUMENTS.
 - STRUCTURAL DESIGN BASED ON THE PROVISIONS OF THE NRC, 2018 EDITION (R301.4 - R301.1)
- | DESIGN CRITERIA: | LIVE LOAD (PSF) | DEAD LOAD (PSF) | DEFLECTION (IN) |
|--------------------------------|---|-----------------|-----------------------------------|
| ATTIC WITH LIMITED STORAGE | 20 | 10 | L/240 (L/360 w/ BRITTLE FINISHES) |
| ATTIC WITHOUT STORAGE | 10 | 10 | L/360 |
| DECKS | 40 | 10 | L/360 |
| EXTERIOR BALCONIES | 40 | 10 | L/360 |
| FIRE ESCAPES | 40 | 10 | L/360 |
| HANDRAILS/GUARDRAILS | 200 LB OR 50 (PLF) | 10 | L/360 |
| PASSENGER VEHICLE GARAGE | 50 | 10 | L/360 |
| ROOMS OTHER THAN SLEEPING ROOM | 40 | 10 | L/360 |
| SLEEPING ROOMS | 30 | 10 | L/360 |
| STAIRS | 40 | 10 | L/360 |
| WIND LOAD | (BASED ON TABLE R301.2(4) WIND ZONE AND EXPOSURE) | | |
| GROUND SNOW LOAD, Pg | 20 (PSF) | | |
- I-JOIST SYSTEMS DESIGNED WITH 12 PSF DEAD LOAD AND DEFLECTION (IN) OF L/480
 - FLOOR TRUSS SYSTEMS DESIGNED WITH 15 PSF DEAD LOAD
- FOR 115 AND 120 MPH WIND ZONES, FOUNDATION ANCHORAGE IS TO COMPLY WITH SECTION R403.1.6 OF THE NRC, 2018 EDITION. FOR 130 MPH, 140 MPH, AND 150 MPH WIND ZONES, FOUNDATION ANCHORAGE IS TO COMPLY WITH SECTION 4504 OF THE NRC, 2018 EDITION.
 - ENERGY EFFICIENCY COMPLIANCE AND INSULATION VALUES OF THE BUILDING TO BE IN ACCORDANCE WITH CHAPTER 11 OF THE NRC, 2018 EDITION.

FOOTING AND FOUNDATION NOTES

- FOUNDATION DESIGN BASED ON A MINIMUM ALLOWABLE BEARING CAPACITY OF 2000 PSF. CONTACT GEOTECHNICAL ENGINEER IF BEARING CAPACITY IS NOT ACHIEVED.
- FOR ALL CONCRETE SLABS AND FOOTINGS, THE AREA WITHIN THE PERIMETER OF THE BUILDING ENVELOPE SHALL HAVE ALL VEGETATION, TOP SOIL AND FOREIGN MATERIAL REMOVED. FILL MATERIAL SHALL BE FREE OF VEGETATION AND FOREIGN MATERIAL. THE FILL SHALL BE COMPACTED TO ASSURE UNIFORM SUPPORT OF THE SLAB, AND EXCEPT WHERE APPROVED, THE FILL DEPTHS SHALL NOT EXCEED 24" FOR CLEAN SAND OR GRAVEL. A 4" THICK BASED COURSE CONSISTING OF CLEAN GRADED SAND OR GRAVEL SHALL BE PLACED. A BASE COURSE IS NOT REQUIRED WHERE A CONCRETE SLAB IS INSTALLED ON WELL-DRAINED OR SAND-GRAVEL MIXTURE SOILS CLASSIFIED AS GROUP 1, ACCORDING TO THE UNITED SOIL CLASSIFICATION SYSTEM IN ACCORDANCE WITH TABLE R405.1 OF THE NRC, 2018 EDITION.
- PROPERLY DEWATER EXCAVATION PRIOR TO POURING CONCRETE WHEN BOTTOM OF CONCRETE SLAB IS AT OR BELOW WATER TABLE. IF APPLICABLE, 3/4" - 1" DEEP CONTROL JOINTS ARE TO BE SAUED WITHIN 4 TO 12 HOURS OF CONCRETE FINISHING AND WALL LOCATIONS HAVE BEEN MARKED. ADJUST WHERE NECESSARY.
- CONCRETE SHALL CONFORM TO SECTION R402.2 OF THE NRC, 2018 EDITION. CONCRETE REINFORCING STEEL TO BE ASTM A615 GRADE 60. WELDED WIRE FABRIC TO BE ASTM A185. MAINTAIN A MINIMUM CONCRETE COVER AROUND REINFORCING STEEL OF 3" IN FOOTINGS AND 1 1/2" IN SLABS. FOR POURED CONCRETE WALLS, CONCRETE COVER FOR REINFORCING STEEL MEASURED FROM THE INSIDE FACE OF THE WALL SHALL NOT BE LESS THAN 3/4". CONCRETE COVER FOR REINFORCING STEEL MEASURED FROM THE OUTSIDE FACE OF THE WALL SHALL NOT BE LESS THAN 1 1/2" FOR #5 BARS OR SMALLER, AND NOT LESS THAN 2" FOR #6 BARS OR LARGER.
- MASONRY UNITS TO CONFORM TO ACE 530/ASCE 5/TMS 402. MORTAR SHALL CONFORM TO ASTM C270.
- THE UNSUPPORTED HEIGHT OF MASONRY PIERS SHALL NOT EXCEED FOUR TIMES THEIR LEAST DIMENSION FOR UNFILLED HOLLOW CONCRETE MASONRY UNITS AND TEN TIMES THEIR LEAST DIMENSION FOR SOLID OR SOLID FILLED PIERS. PIERS MAY BE FILLED SOLID WITH CONCRETE OR TYPE M OR S MORTAR. PIERS AND WALLS SHALL BE CAPPED WITH 8" OF SOLID MASONRY.
- THE CENTER OF EACH OF THE PIERS SHALL BEAR IN THE MIDDLE THIRD OF ITS RESPECTIVE FOOTING. EACH GIRDER SHALL BEAR IN THE MIDDLE THIRD OF THE PIERS.
- ALL CONCRETE AND MASONRY FOUNDATION WALLS ARE TO BE CONSTRUCTED IN ACCORDANCE WITH THE PROVISIONS OF SECTION R404 OF THE NRC, 2018 EDITION OR IN ACCORDANCE WITH ACI 318, ACI 332, NCMIA TR68-A OR ACE 530/ASCE 5/TMS 402. MASONRY FOUNDATION WALLS ARE TO BE REINFORCED PER TABLE R404.1(1), R404.1(2), R404.1(3), OR R404.1(4) OF THE NRC, 2018 EDITION. CONCRETE FOUNDATION WALLS ARE TO BE REINFORCED PER TABLE R404.1(5) OF THE NRC, 2018 EDITION. STEP CONCRETE FOUNDATION WALLS TO 2 x 6 FRAMED WALLS AT 16" O.C. WHERE GRADE PERMITS (UNO).

This sealed page is to be used in conjunction with a full plan set engineered by J.S. Thompson Engineering, Inc. only. Use of this individual sealed page within architectural pages or shop drawings by others is a punishable offense under N.C. Statute § 89C-23

FRAMING NOTES

- ALL FRAMING LUMBER SHALL BE #2 SFF MINIMUM (Fb = 875 PSI, Fv = 375 PSI, E = 1600000 PSI) UNLESS NOTED OTHERWISE (UNO). ALL TREATED LUMBER SHALL BE #2 SYP MINIMUM (Fb = 975 PSI, Fv = 175 PSI, E = 1600000 PSI) UNLESS NOTED OTHERWISE (UNO).
- LAMINATED VENEER LUMBER (LVL) SHALL HAVE THE FOLLOWING MINIMUM PROPERTIES: Fb = 2600 PSI, Fv = 285 PSI, E = 1900000 PSI. LAMINATED STRAND LUMBER (LSL) SHALL HAVE THE FOLLOWING MINIMUM PROPERTIES: Fb = 2325 PSI, Fv = 310 PSI, E = 1550000 PSI. PARALLEL STRAND LUMBER (PSL) UP TO 1" DEPTH SHALL HAVE THE FOLLOWING MINIMUM PROPERTIES: Fc = 7500 PSI, E = 1800000 PSI. PARALLEL STRAND LUMBER (PSL) MORE THAN 1" DEPTH SHALL HAVE THE FOLLOWING MINIMUM PROPERTIES: Fc = 7300 PSI, E = 2000000 PSI. INSTALL ALL CONNECTIONS PER MANUFACTURER'S SPECIFICATIONS.
- STRUCTURAL STEEL SHALL CONFORM TO THE FOLLOWING ASTM SPECIFICATIONS

A. W AND WT SHAPES:	ASTM A992
B. CHANNELS AND ANGLES:	ASTM A36
C. FLATES AND BARS:	ASTM A36
D. HOLLOW STRUCTURAL SECTIONS:	ASTM A500 GRADE B
E. STEEL PIPE:	ASTM A53, GRADE B, TYPE E OR S
- STEEL BEAMS SHALL BE SUPPORTED AT EACH END WITH A MINIMUM BEARING LENGTH OF 3 1/2" AND FULL FLANGE WIDTH (UNO). PROVIDE SOLID BEARING FROM BEAM SUPPORT TO FOUNDATION. BEAMS SHALL BE ATTACHED AT THE BOTTOM FLANGE TO EACH SUPPORT AS FOLLOWS (UNO):

A. WOOD FRAMING	(2) 1/2" DIA. x 4" LONG LAG SCREWS
B. CONCRETE	(2) 1/2" DIA. x 4" WEDGE ANCHORS
C. MASONRY (FULLY GROUTED)	(2) 1/2" DIA. x 4" LONG SIMPSON TITEN HD ANCHORS

LATERAL SUPPORT IS CONSIDERED ADEQUATE PROVIDING THE JOISTS ARE TOE NAILED TO THE 2x NAILER ON TOP OF THE STEEL BEAM, AND THE 2x NAILER IS SECURED TO THE TOP OF THE STEEL BEAM w/ (2) ROWS OF SELF TAPPING SCREWS @ 16" O.C. OR (2) ROWS OF 1/2" DIAMETER BOLTS @ 16" O.C. IF 1/2" BOLTS ARE USED TO FASTEN THE NAILER, THE STEEL BEAM SHALL BE FABRICATED w/ (2) ROWS OF 9/16" DIAMETER HOLES @ 16" O.C.
- SQUARES DENOTE POINT LOADS WHICH REQUIRE SOLID BLOCKING TO GIRDER OR FOUNDATION. SHADED SQUARES DENOTE POINT LOADS FROM ABOVE WHICH REQUIRE SOLID BLOCKING TO SUPPORTING MEMBER BELOW.
- ALL LOAD BEARING HEADERS TO CONFORM TO TABLE R602.7(1) AND R602.7(2) OF THE NRC, 2018 EDITION OR BE (2) 2 x 6 WITH (1) JACK AND (1) KING STUD EACH END (UNO) WHICHEVER IS GREATER. ALL HEADERS TO BE SECURED TO EACH JACK STUD WITH (4) 8d NAILS. ALL BEAMS TO BE SUPPORTED WITH (2) STUDS AT EACH BEARING POINT (UNO). INSTALL KING STUDS PER SECTION R602.15 OF THE NORTH CAROLINA RESIDENTIAL CODE, 2018 EDITION.
- ALL BEAMS, HEADERS, OR GIRDER TRUSSES PARALLEL TO WALL ARE TO BEAR FULLY ON (1) JACK OR (2) STUDS MINIMUM OR THE NUMBER OF JACKS OR STUDS NOTED. ALL BEAMS OR GIRDER TRUSSES PERPENDICULAR TO WALL AND SUPPORTED BY (3) STUDS OR LESS ARE TO HAVE 1 1/2" MINIMUM BEARING (UNO). ALL BEAMS OR GIRDER TRUSSES PERPENDICULAR TO WALL AND SUPPORTED BY MORE THAN (3) STUDS OR OTHER NOTED COLUMN ARE TO BEAR FULLY ON SUPPORT COLUMN FOR ENTIRE WALL DEPTH (UNO). BEAM ENDS THAT BUTT INTO ONE ANOTHER ARE TO EACH BEAR EQUAL LENGTHS (UNO).
- FLITCH BEAMS SHALL BE BOLTED TOGETHER USING 1/2" DIAMETER BOLTS (ASTM A307) WITH WASHERS PLACED AT THREADED END OF BOLT. BOLTS SHALL BE SPACED AT 24" CENTERS (MAXIMUM), AND STAGGERED AT TOP AND BOTTOM OF BEAM (2" EDGE DISTANCE) WITH (2) BOLTS LOCATED AT 6" FROM EACH END (UNO).
- ALL I-JOIST OR TRUSS LAYOUTS ARE TO BE IN COMPLIANCE WITH THE OVERALL DESIGN SPECIFIED ON THE PLANS. ALL DEVIATIONS ARE TO BE BROUGHT TO THE ATTENTION OF THE ENGINEER OF RECORD PRIOR TO INSTALLATION.
- BRACED WALL PANELS SHALL BE CONSTRUCTED ACCORDING TO THE NORTH CAROLINA RESIDENTIAL CODE 2018 EDITION WALL BRACING CRITERIA. THE AMOUNT, LENGTH, AND LOCATION OF BRACING SHALL COMPLY WITH ALL APPLICABLE TABLES IN SECTION R602.10.
- PROVIDE DOUBLE JOIST UNDER ALL WALLS PARALLEL TO FLOOR JOISTS. PROVIDE SUPPORT UNDER ALL WALLS PARALLEL TO FLOOR TRUSSES OR I-JOISTS PER MANUFACTURER'S SPECIFICATIONS. INSTALL BLOCKING BETWEEN JOISTS OR TRUSSES FOR POINT LOAD SUPPORT FOR ALL POINT LOADS ALONG OFFSET LOAD LINES.
- FOR ALL HEADERS SUPPORTING BRICK VENEER THAT ARE LESS THAN 8'-0" IN LENGTH, REST A 6" x 4" x 5/16" STEEL ANGLE WITH 6" MINIMUM EMBEDMENT AT SIDES FOR BRICK SUPPORT (UNO). FOR ALL HEADERS 8'-0" AND GREATER IN LENGTH, BOLT A 6" x 4" x 5/16" STEEL ANGLE TO HEADER WITH 1/2" LAG SCREWS AT 12" O.C. STAGGERED FOR BRICK SUPPORT. FOR ALL BRICK SUPPORT AT ROOF LINES, BOLT A 6" x 4" x 5/16" STEEL ANGLE TO (2) 2 x 10 BLOCKING INSTALLED w/ (4) 12d NAILS EA. PLY BETWEEN WALL STUDS WITH (2) ROWS OF 1/2" LAG SCREWS AT 12" O.C. STAGGERED AND IN ACCORDANCE WITH SECTION R703.2(1) OF THE NRC, 2018 EDITION.
- FOR STICK FRAMED ROOFS, CIRCLES DENOTE (3) 2 x 4 POSTS FOR ROOF MEMBER SUPPORT. HIP SPLICES ARE TO BE SPACED A MINIMUM OF 8'-0". FASTEN MEMBERS WITH THREE ROWS OF 12d NAILS AT 16" O.C. FRAME DORMER WALLS ON TOP OF DOUBLE OR TRIPLE RAFTERS AS SHOWN (UNO).
- FOR TRUSSED ROOFS, FRAME DORMER WALLS ON TOP OF 2 x 4 LADDER FRAMING AT 24" O.C. BETWEEN ADJACENT ROOF TRUSSES. STICK FRAME OVER-FRAMED ROOF SECTIONS WITH 2 x 8 RIDGES, 2 x 6 RAFTERS AT 16" O.C. AND FLAT 2 x 10 VALLEYS (UNO).
- ALL 4 x 4 AND 6 x 6 POSTS TO BE INSTALLED WITH 100 LB CAPACITY UPLIFT CONNECTORS TOP AND BOTTOM (UNO). POSTS MAY BE SECURED USING ONE SIMPSON 16 OR L7512 UPLIFT CONNECTOR FASTENED TO THE BAND AT THE BOTTOM AND THE BEAM AT THE TOP OF EACH POST. ONE 16" SECTION OF SIMPSON C516 COIL STRAPPING WITH (8) 8d HDG NAILS AT EACH END MAY BE USED IN LIEU OF EACH TWIST STRAP IF DESIRED. FOR MASONRY OR CONCRETE FOUNDATION USE SIMPSON POST BASE.

J.S. THOMPSON ENGINEERING, INC
 606 WADE AVE., SUITE 104 RALEIGH, NC 27605
 PHONE: (919) 789-9919 FAX: (919) 789-9921
 N.C. LICENSE NO.: C-1733

120 MPH - 130 MPH ULTIMATE DESIGN WIND SPEED
 STANDARD STRUCTURAL NOTES



DATE: NOVEMBER 14, 2018
SCALE: 1/4" = 1'-0"
DRAWN BY: JES
ENGINEERED BY: JST

S-0
 STRUCTURAL NOTES