

**FRONT ELEVATION 3**

SCALE: 1/8" = 1'-0"



**REAR ELEVATION 3**

SCALE: 1/8" = 1'-0"

MASTER PLAN INFORMATION	
REVISION DATE	03-06-2019
REVISION	R2-RALE
UPDATED DATE	02-17-2022

DRAWN BY:	ITS
DATE:	03/21/2022
PLAN NO.	2695

HOUSE NAME:	DRAYTON
DRAWING TITLE	FRONT & REAR ELEVATIONS

SHEET No.	A.I.
-----------	------

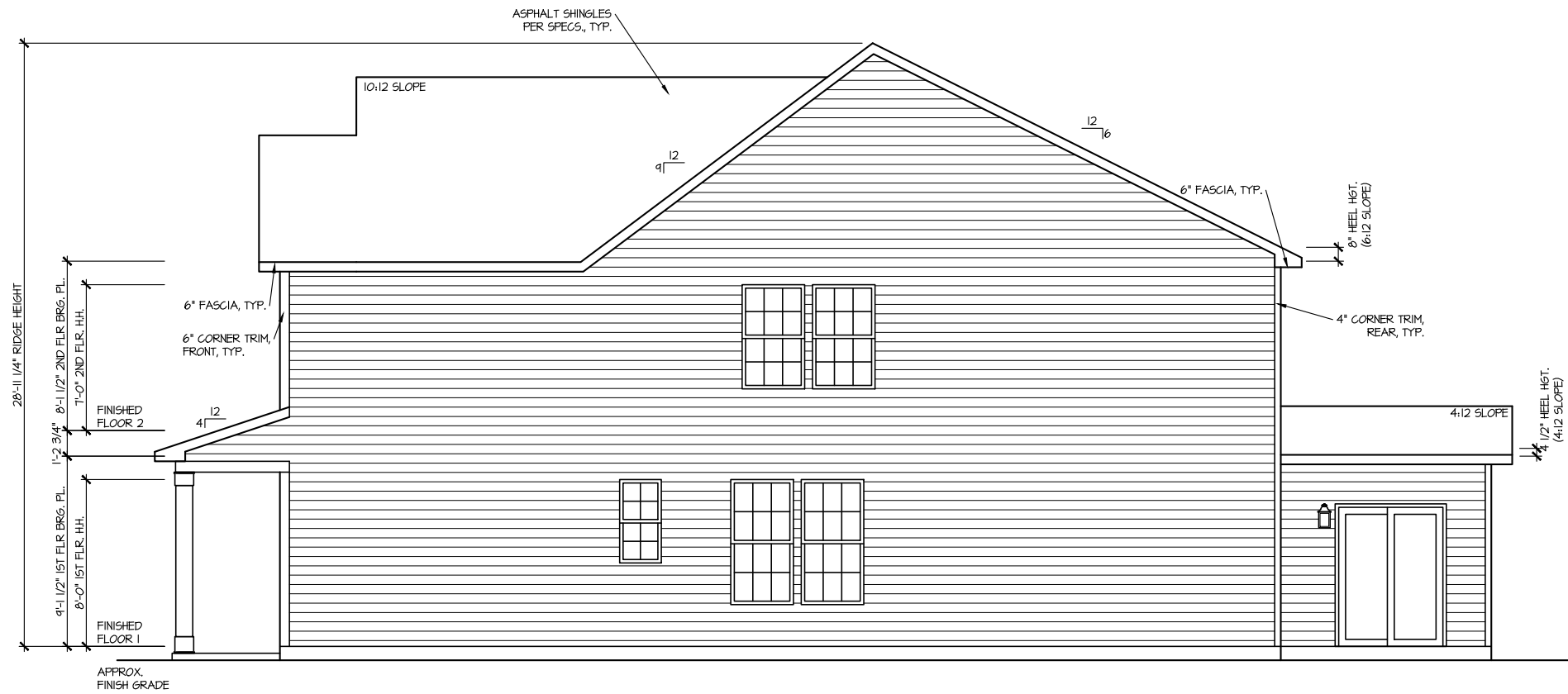

**RIGHT ELEVATION 3**

SCALE: 1/8" = 1'-0"

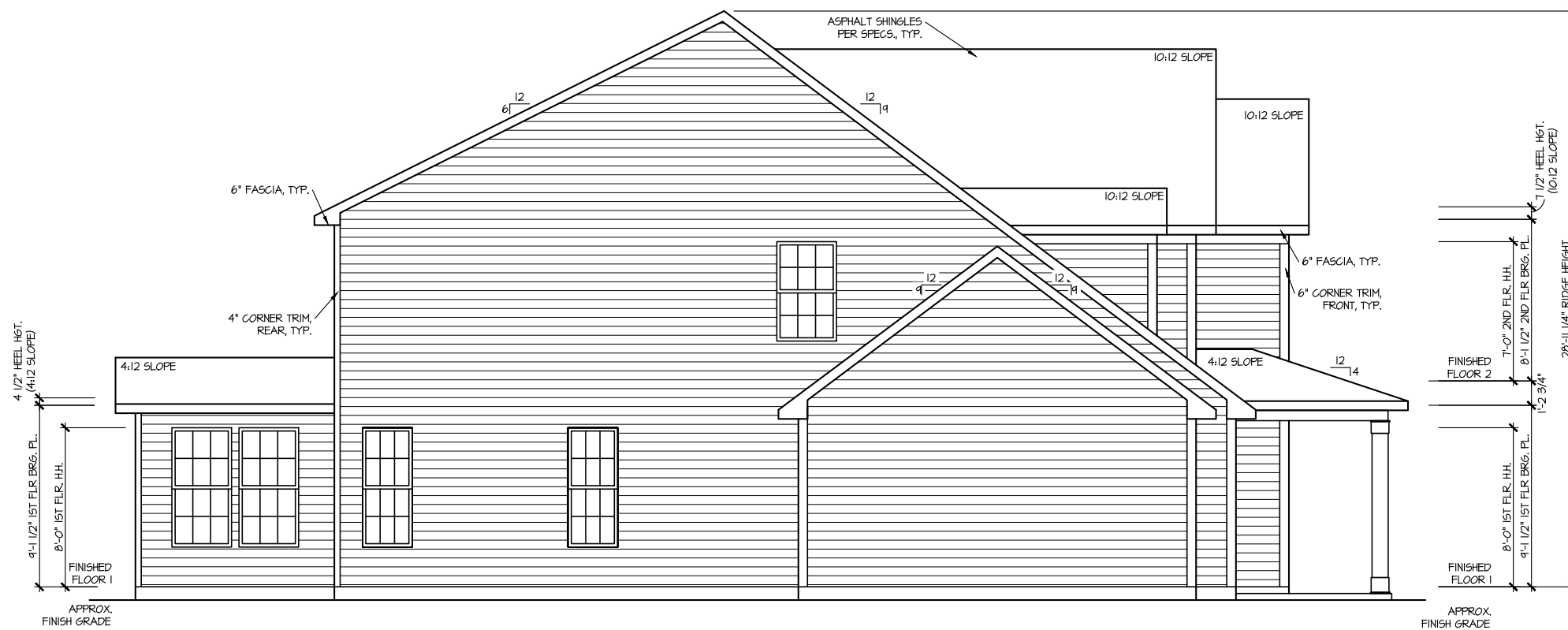

**LEFT ELEVATION 3**

SCALE: 1/8" = 1'-0"

MASTER PLAN INFORMATION	
REVISION	DATE
R2-RALE	03-06-2019
UPDATED DATE	02-17-2022

DRAWN BY:  
ITS  
DATE:  
03/21/2022  
PLAN NO.  
2695



HOUSE NAME:  
**DRAYTON**  
DRAWING TITLE  
**RIGHT & LEFT ELEVATIONS**

SHEET No.  
**A1.2**





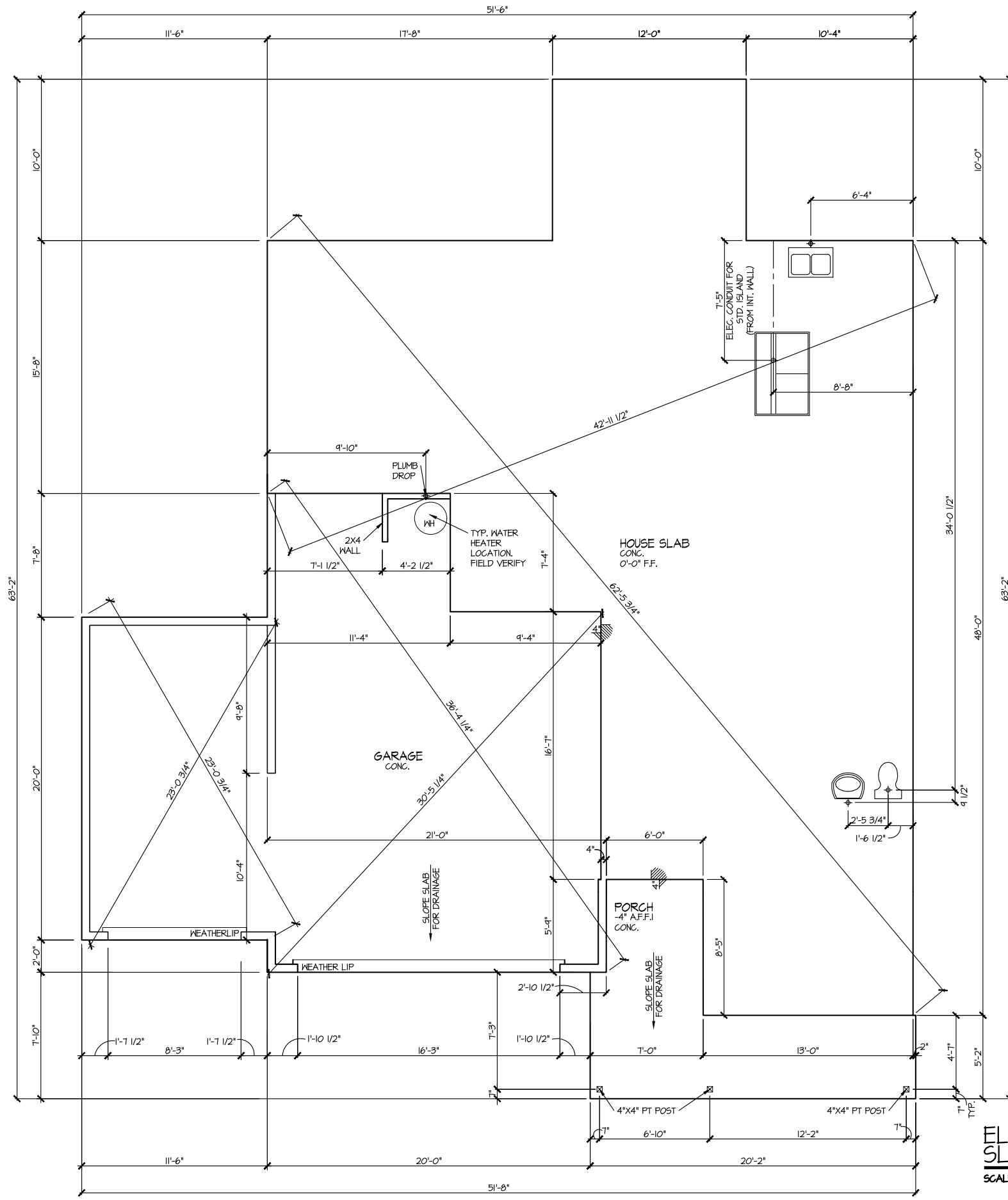





**ELEVATION 3  
SLAB PLAN**

SCALE: 1/8" = 1'-0"

MASTER PLAN INFORMATION	
REVISION	DATE
R2-RALE	03-06-2019
UPDATED DATE	02-17-2022

DRAWN BY:	ITS
DATE:	03/21/2022
PLAN NO.	2695

HOUSE NAME:	<b>DRAYTON</b>
DRAWING TITLE	<b>SLAB PLAN</b>

SHEET No.	<b>A2.1</b>
-----------	-------------

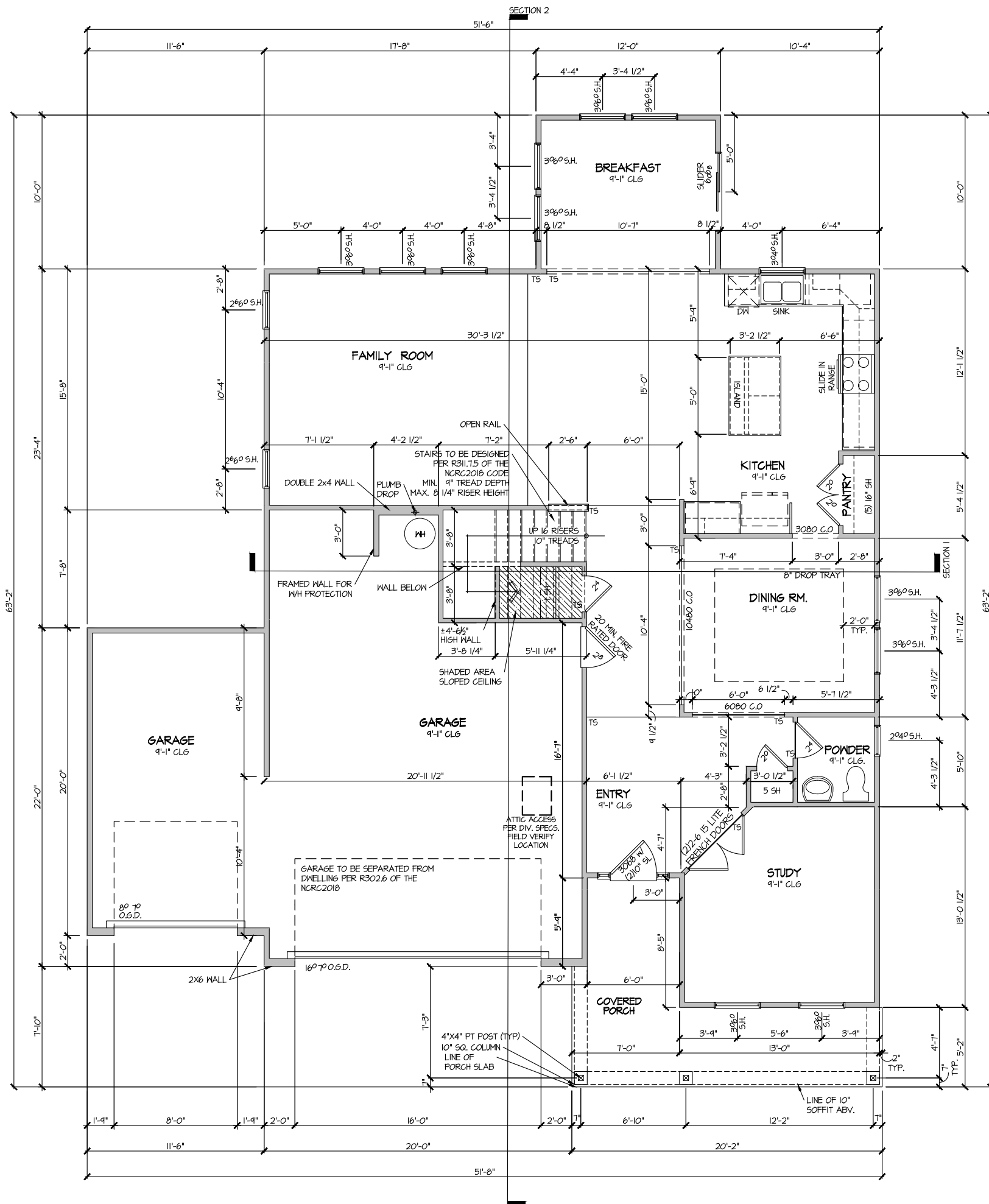

**ELEVATION 3  
FIRST FLOOR PLAN**  
SCALE: 1/8" = 1'-0"

MASTER PLAN INFORMATION	
REVISION	DATE
R2-RALE	03-06-2019
UPDATED DATE	02-17-2022

DRAWN BY:	ITS
DATE:	03/21/2022
PLAN NO.	2695

**DRB**  
DRB GROUP

**DRB**  
FIELDING

**DRB**  
Central

**DAN RYAN**  
ARCHITECT

HOUSE NAME:	DRAYTON
DRAWING TITLE	FIRST FLOOR PLAN

SHEET No.	A3.1
-----------	------

FILE: Lot\_00.0096.dwg DATE: 3/21/2022

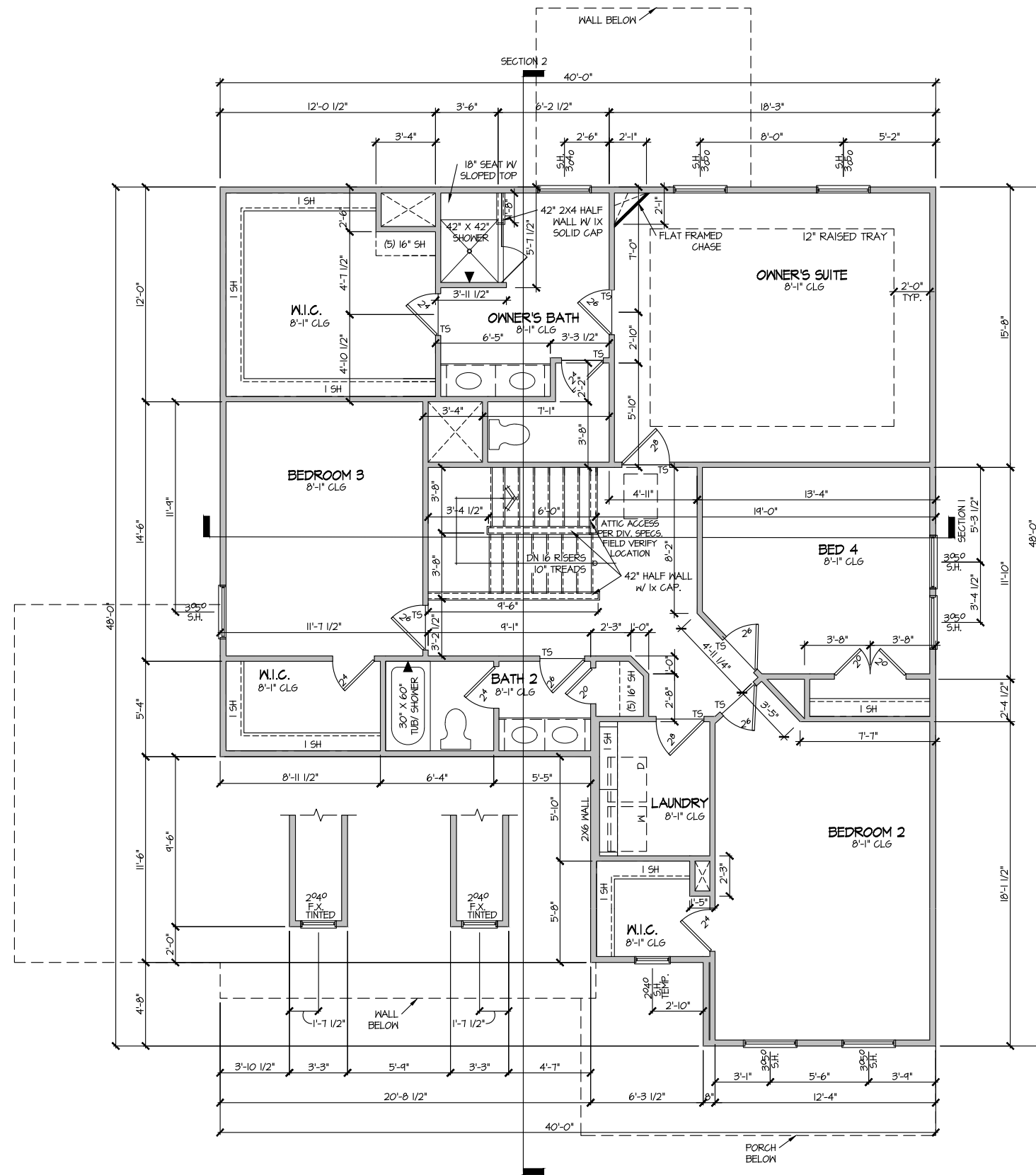

ELEVATION 3  
 SECOND FLOOR PLAN  
 SCALE: 1/8" = 1'-0"

MASTER PLAN INFORMATION	
REVISION	DATE
R2-RALE	03-06-2019
UPDATED DATE	02-17-2022

DRAWN BY:	ITS
DATE:	03/21/2022
PLAN NO.	2695

DRB  
 DRB GROUP  
 DRB Central  
 FIELDING  
 DAN RYAN  
 UNIVERSITY

HOUSE NAME:	DRAYTON
DRAWING TITLE	SECOND FLOOR PLAN

SHEET No.	A3.2
-----------	------

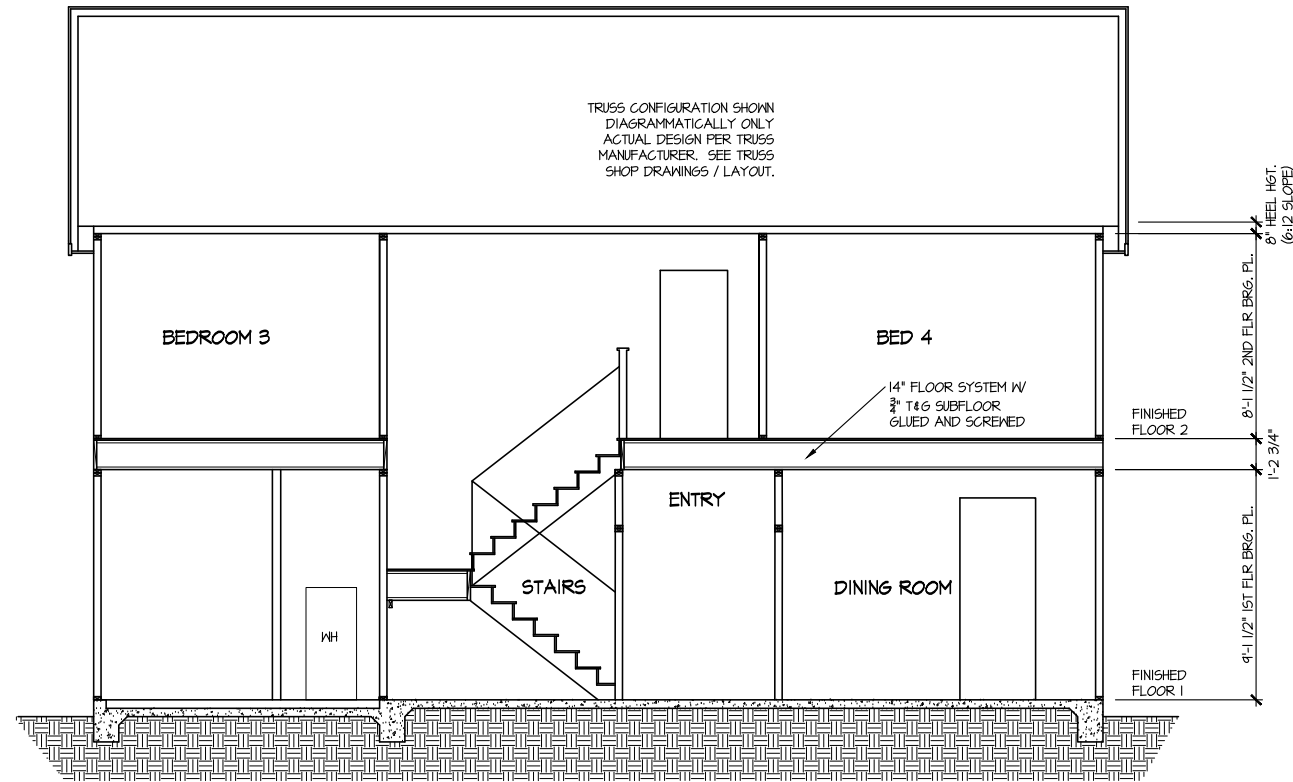

**SECTION 1**  
SCALE: 1/8" = 1'-0"

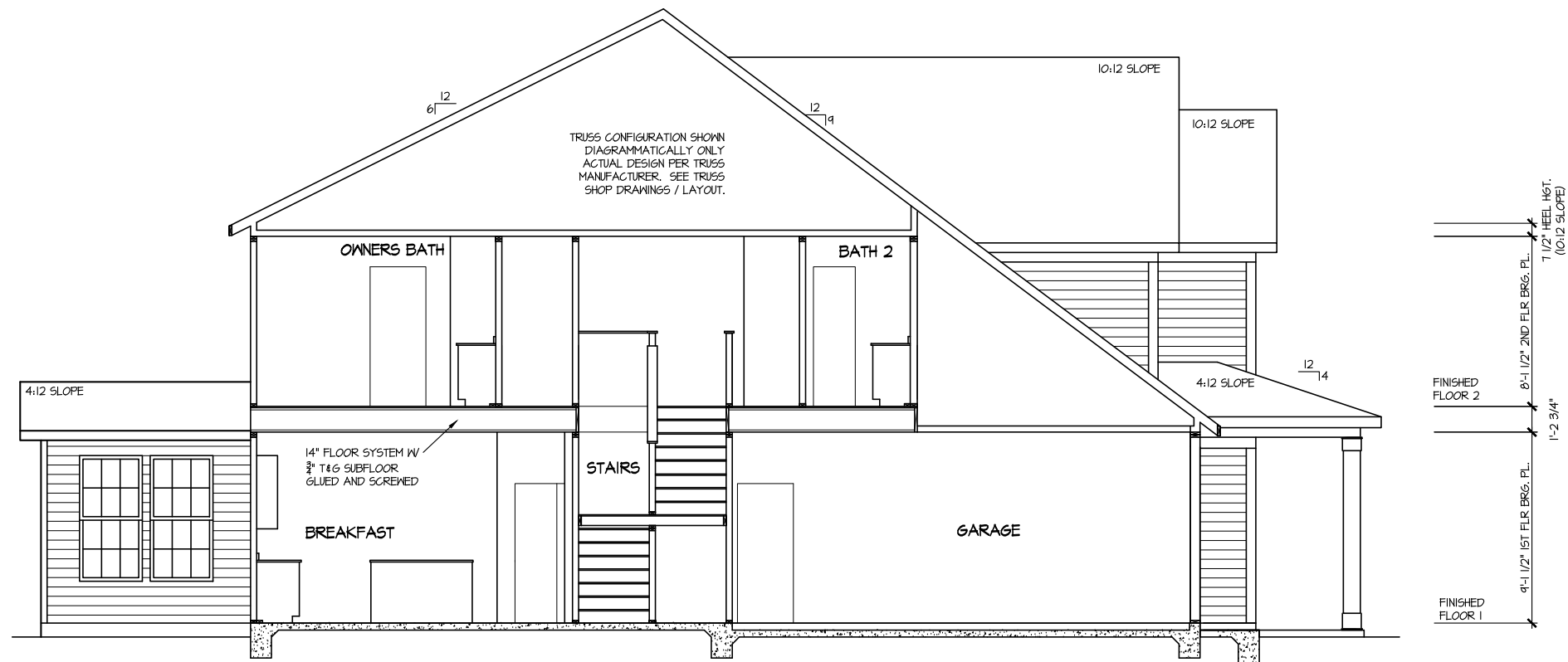

**SECTION 2**  
SCALE: 1/8" = 1'-0"

MASTER PLAN INFORMATION	
REVISION	DATE
R2-RALE	03-06-2019
UPDATED DATE	02-17-2022

DRAWN BY:  
ITS  
DATE:  
03/21/2022  
PLAN NO.  
2695

DRB GROUP  
FIELDING  
DRB Central  
DRB GROUP  
FIELDING  
DRB Central

HOUSE NAME:  
**DRAYTON**  
DRAWING TITLE  
BUILDING SECTION

SHEET No.  
**A4.1**



**ELECTRICAL LEGEND**

- Ⓢ SINGLE POLE SWITCH
- Ⓢ<sub>3</sub> THREE WAY SWITCH
- Ⓢ<sub>4</sub> FOUR WAY SWITCH
- ⓈⓈ DUPLEX AFCI RECEPTACLE
- ⓈⓈ<sub>B</sub> DUPLEX AFCI RECEPTACLE - BOTTOM HALF SWITCHED
- ⓈⓈ<sub>F</sub> DUPLEX AFCI RECEPTACLE - FLOOR MOUNTED
- 220V Ⓢ RECEPTACLE - 220V
- ⓈⓈ<sub>GFI</sub> DUPLEX AFCI RECEPTACLE - GFI
- ⓈⓈ<sub>WP/GFI</sub> DUPLEX AFCI RECEPTACLE - WATERPROOF GFI
- ⓈⓈ<sub>SD</sub> SMOKE DETECTOR - WIRED IN SERIES
- ⓈⓈ<sub>EF</sub> EXHAUST FAN MOTOR
- ⓈⓈ<sub>CO</sub> CO DETECTOR
- ⓈⓈ<sub>DC</sub> DOOR CHIME
- ⓈⓈ<sub>LM</sub> LIGHT FIXTURE - WALL MOUNTED
- ⓈⓈ<sub>LC</sub> LIGHT FIXTURE - CEILING MOUNTED
- ⓈⓈ<sub>RC</sub> LIGHT FIXTURE - RECESSED CAN
- ⓈⓈ<sub>LSM</sub> LIGHT FIXTURE - LED SURFACE MOUNTED
- ⓈⓈ<sub>LED</sub> LED
- ⓈⓈ<sub>FL</sub> FULLCHAIN LAMPHOLDER
- ⓈⓈ<sub>K</sub> KEYLESS LAMPHOLDER

NOTE: ALL ELECTRICAL WORK SHALL CONFORM TO THE REQUIREMENTS OF THE ADOPTED VERSION OF THE NATIONAL ELECTRICAL CODE, THE LOCAL POWER COMPANY AND TO ALL APPLICABLE LOCAL REGULATIONS.

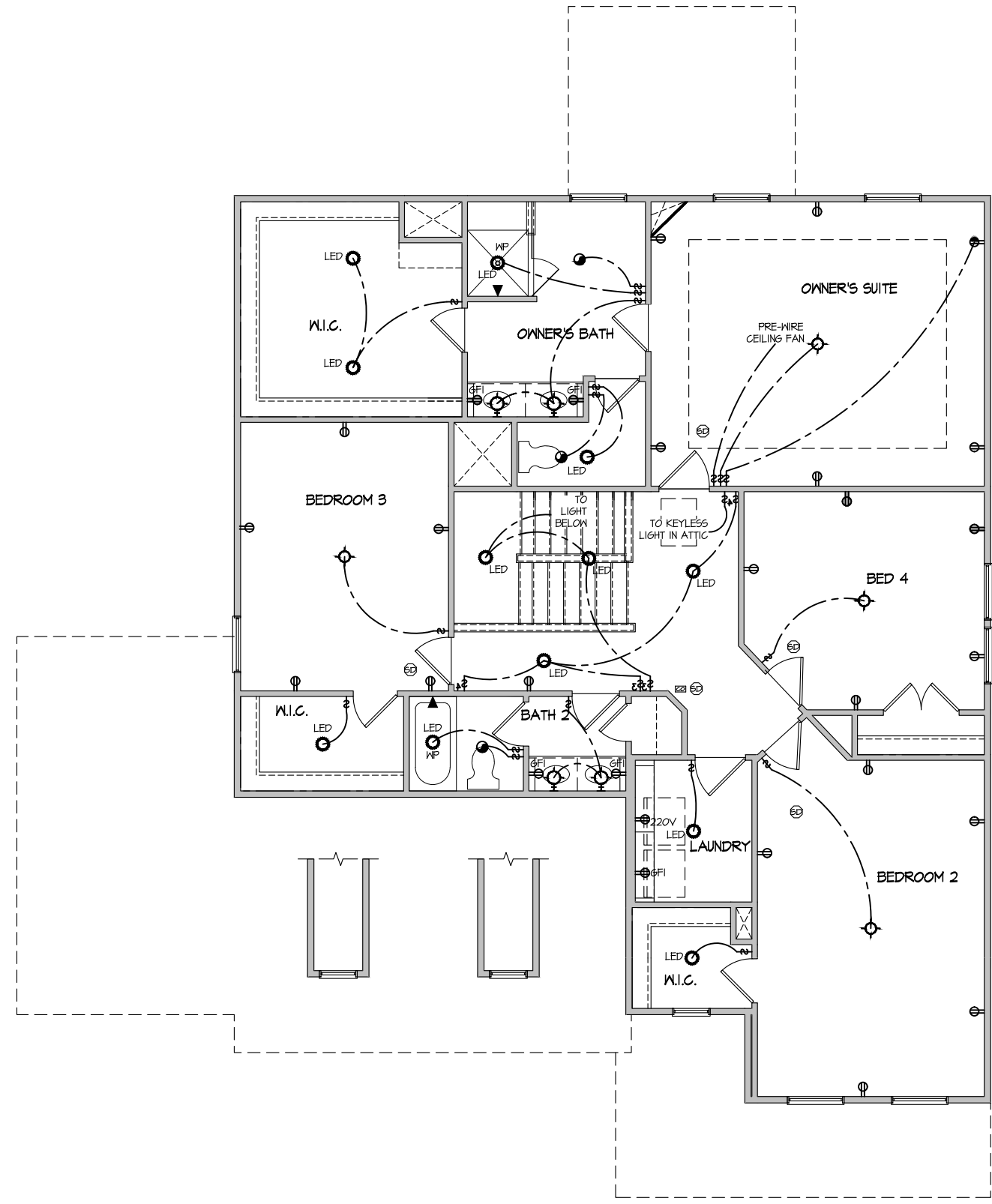

**ELECTRICAL PLAN  
SECOND FLOOR - ELEV. 3**  
SCALE: 1/8" = 1'-0"

MASTER PLAN INFORMATION	
REVISION	DATE
R2-RALE	03-06-2019
UPDATED DATE	02-17-2022

DRAWN BY:	ITS
DATE:	03/21/2022
PLAN NO.	2695

DRB DRB GROUP  
FIELDING  
DRB Central  
DRAYTON BUILDING

HOUSE NAME:	DRAYTON
DRAWING TITLE	SECOND FLOOR ELECTRICAL

SHEET No.	E1.2
-----------	------



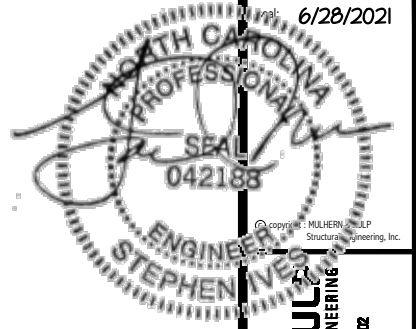

MULHERN+KULP  
RESIDENTIAL STRUCTURAL ENGINEERING  
300 Drayton Ave., Building 4 - Aunim, PA 18002  
P 215-646-8071 - mulhern@mkp.com



MSK project number:

126-21020

project mgr: JTR

drawn by: KL

issue date: 06-12-21

REVISIONS:

date: initial:



FOUNDATION PLANS  
DRAYTON  
RALEIGH, NC

sheet:

SO.0

### GENERAL STRUCTURAL NOTES

#### FOUNDATION

- DESIGN IS BASED ON 2018 NORTH CAROLINA STATE BUILDING CODE: RESIDENTIAL CODE.
- FOOTING DESIGN - 2,000 PSF ALLOWABLE SOIL BEARING PRESSURE IS ASSUMED. BUILDER/CONTRACTOR MUST VERIFY.
- FASTEN 2x4/6 SILL PLATES TO FND WITH A MINIMUM OF 2 ANCHORS PER PLATE, 12" MAX. FROM PLATE ENDS - UTILIZING:
  - 1/2" DIA. ANCHOR BOLTS @ 6'-0" O.C., 7" MIN. EMBEDMENT (CONC), 15" MIN. EMBEDMENT (CMU)
  - SIMPSON MASA ANCHOR STRAPS @ 6'-0" O.C. (CONC)
  - SIMPSON MAB23 ANCHOR STRAPS @ 2'-8" O.C. (CMU)
 (REFER TO DETAILS FOR 10' TALL WALL ANCHOR REQUIREMENTS)
- ALL LUMBER EXPOSED TO WEATHER OR IN CONTACT W/ CONCRETE OR CMU SHALL BE PRESERVATIVE TREATED SOUTHERN PINE #2.
- BUILDER TO VERIFY CORROSION-RESISTANCE COMPATIBILITY OF HARDWARE & FASTENERS IN CONTACT W/ PRESERVATIVE-TREATED WOOD. CONTACT LUMBER & HARDWARE SUPPLIERS TO COORD.
- BASEMENT INTERIOR BEARING WALLS & EXTERIOR WALK-OUT BASEMENT WALLS SHALL BE 2x6 @ 16" O.C. SFF OR SYP, "STUD" GRADE OR BETTER.
- CONCRETE DESIGN BASED ON ACI 318. CONCRETE SHALL ATTAIN THE FOLLOWING MIN. COMPRESSIVE STRENGTHS IN 28 DAYS, UNO.:
  - f'c = 4,000 psi ..... FOUNDATION WALLS
  - 2,500 psi ..... FOOTINGS & INTERIOR SLABS ON GRADE
  - 3,000 psi ..... GARAGE & EXTERIOR SLABS ON GRADE
  - fy = 60,000 psi
- BASEMENT FOUNDATION WALL DESIGN BASED ON:
  - 9' OR 10' HEIGHT (AS NOTED ON PLANS)
  - TALLER WALLS MUST BE ENGINEERED.
  - NOMINAL WIDTH (1/2") FOR 10" THICK WALL.
- BASEMENT WALL DESIGN IS BASED ON 60 PCF BACKFILL SOIL TYPE CLASSIFICATIONS (SC, ML-CL, OR CL).
- BASEMENT WALLS SHALL BE BRACED, PRIOR TO BACKFILLING, BY ADEQUATE TEMPORARY BRACING OR INSTALL 1st FLOOR DECK.
- PROVIDE (2) #5 BARS AROUND ALL SIDES OF OPENINGS IN CONCRETE BSMT. FND. WALL WITH 2" CLEAR. REINFORCEMENT SHALL EXTEND 12" PAST CORNER OF OPENING IN ALL DIRECTIONS.
  - FOR OPENINGS UP TO 36", PROVIDE MINIMUM 10" CONCRETE DEPTH OVER OPENING OR (3)2x10 W/ (2)2x6 JACK STUDS, UNO.
  - LARGER OPENINGS SHALL BE PER PLAN.
- ALL CONCRETE EXPOSED TO THE WEATHER SHALL NOT HAVE LESS THAN 5% OR MORE THAN 1% AIR ENTRAINMENT.
- ALL FOOTINGS SHALL BEAR AT LEAST 12" BELOW FINISH GRADE.
- FOOTINGS AND SLABS ON GRADE SHALL BEAR ON VIRGIN SOIL OR 95% COMPACTED FILL.
- PROVIDE CONTROL JOINTS AT ALL INSIDE CORNERS OF SLAB EDGES, AND OTHER LOCATIONS WHERE SLAB CRACKS ARE LIKELY TO DEVELOP.
  - JOINTS SHALL BE LOCATED @ 10'-0" O.C. (RECOMMENDED) OR 15'-0" O.C. (MAXIMUM)
  - JOINT GRID PATTERN SHALL BE AS CLOSE TO SQUARES AS POSSIBLE (1:1 RATIO), WITH A MAXIMUM OF 1:1.5 RATIO
  - CONTROL JOINTS SHALL NOT BE INSTALLED IN STRUCTURAL SLABS
- CONCRETE MASONRY UNITS (CMU) SHALL BE ASTM C90 WITH A MIN. COMPRESSIVE STRENGTH OF 1900 psi (F'm=1500 psi). MORTAR SHALL BE ASTM C270, TYPE S. CMU DESIGN PER ACI 530 & 530.1.
- CMU FOUNDATION WALLS SHALL HAVE "DUR-O-WALL" HORIZONTAL JOINT REINFORCEMENT (OR EQUAL) - 9 GA. MINIMUM @ 16" O.C.
- PROVIDE 2x8 x 16" LONG P.T. PLATE ON TOP OF ALL CRAWL SPACE PIERS. ALL PIERS SHALL BE GROUTED SOLID.
- PROVIDE 2x6 P.T. PLATE ON INTERIOR CRAWL SPACE WALLS, FASTENED PER ANCHORAGE SPECIFICATION NOTED ABOVE.
- DIMENSIONS BY OTHERS, BUILDER TO VERIFY.
- BUILDER TO VERIFY THAT MODEL HAS BEEN ADEQUATELY TREATED BY A LICENSED AND BONDED PEST CONTROL COMPANY FOR SUBTERRANEAN TERMITES. METHOD AND TYPE OF TREATMENT TO BE DETERMINED BY PEST CONTROL COMPANY.

### MEANS & METHODS NOTES

THE STRUCTURE IS DESIGNED TO BE SELF SUPPORTING AND STABLE AFTER THE BUILDING IS FINISHED AND ALL PLAN, DETAIL, AND NOTE SPECIFICATIONS HAVE BEEN COMPLETED. IT IS THE CONTRACTORS SOLE RESPONSIBILITY TO DETERMINE THE ERECTION PROCEDURES AND SEQUENCE TO INSURE THE SAFETY OF THE BUILDING AND ITS COMPONENTS DURING CONSTRUCTION. THIS INCLUDES, BUT IS NOT LIMITED TO, THE ADDITION OF NECESSARY SHORING, SHEETING, TEMPORARY BRACING, GUYS, AND TIE-DOWNS. CONTRACTOR SHALL BE RESPONSIBLE FOR ALL SHORING AND BRACING REQUIRED TO STABILIZE AND PROTECT EXISTING AND ADJACENT STRUCTURES AND SYSTEMS DURING COURSE OF DEMOLITION AND CONSTRUCTION OF THE PROJECT.

STRUCTURAL DESIGN AND SPECIFICATIONS ASSUME THAT ALL SUPPORTING AND NON-SUPPORTING ELEMENTS IN CONTACT WITH FLOOR FRAMING ARE LEVEL, INCLUDING, BUT NOT LIMITED TO; FOUNDATIONS, SLABS ON GRADE, BEAMS, WALLS, AND NON-BEARING ELEMENTS. IT IS THE CONTRACTORS RESPONSIBILITY TO VERIFY LEVELNESS AND MAKE ADJUSTMENTS AS NECESSARY, INCLUDING CONSIDERATION OF THOSE AREAS THAT MAY BE WITHIN CONTRACTUAL, INDUSTRY, OR WARRANTY TOLERANCES.

### ADDITIONAL NOTES FOR TRUSS & I-JOIST MANUFACTURER

ROOF TRUSS, FLOOR TRUSS AND ENGINEERED JOISTS SHALL BE DESIGNED TO MEET THE DIFFERENTIAL DEFLECTION CRITERIA BELOW, UNLESS NOTED OTHERWISE ON PLAN. MULHERN & KULP CANNOT BE HELD RESPONSIBLE FOR ANY STRUCTURAL ISSUES RELATED TO ANY BUILDING COMPONENT IF COMPONENT SHOP DRAWINGS ARE NOT SUBMITTED TO MK FOR REVIEW PRIOR TO FABRICATION, DELIVERY, OR INSTALLATION.

TRUSSES/JOISTS SHALL BE DESIGNED SO THAT DIFFERENTIAL DEFLECTION BETWEEN ADJACENT PARALLEL TRUSSES/JOISTS OR GIRDER TRUSSES/FLUSH BEAMS DO NOT EXCEED THE FOLLOWING:

- ROOF TRUSSES: 1/4" DEAD LOAD
- FLOOR TRUSSES, ATTIC TRUSSES, & I-JOISTS: 1/8" DEAD LOAD
- FLOOR TRUSSES & ATTIC TRUSSES ADJACENT TO FLOOR FRAMING BY OTHERS: LIMIT ABSOLUTE TRUSS DEFLECTION TO 3/16" DEAD LOAD. (NOT DIFFERENTIAL DEFLECTION)

### VEENER LINTEL SCHEDULE

SPAN (MAX)	HEIGHT OF VEENER ABOVE LINTEL	STEEL ANGLE SIZE
3'-0"	20 FT. MAX	L3"x3"x1/4"
	3 FT. MAX	L3"x3"x1/4"
6'-0"	12 FT. MAX	L4"x3"x1/4"
	20 FT. MAX	L5"x3"x3/8"
8'-0"	3 FT. MAX	L4"x4"x1/4" **
	12 FT. MAX	L5"x3"x3/8"
	16 FT. MAX	L6"x3"x3/8"
9'-6"	12 FT. MAX	L6"x3"x3/8"
16'-0"	2 FT. MAX	L7"x4"x1/2" **
	3 FT. MAX	L8"x4"x1/2" **

ALL LINTELS:  
 - SHALL SUPPORT 2 3/4" - 3 1/2" VEENER W/ 40 psf MAXIMUM WEIGHT.  
 - 10" SHALL HAVE 4" MIN BEARING  
 - 16" SHALL HAVE 8" MIN BEARING  
 - 18" SHALL NOT BE FASTENED BACK TO HEADER.  
 - 16" SHALL BE FASTENED BACK TO WOOD HEADER IN WALL @ 48" O.C. W/ 1/2" DIA. x 3 1/2" LONG LAG SCREWS IN 2" LONG VERTICALLY SLOTTED HOLES.  
 - MAX. VEENER HT. APPLIES TO ANY PORTION OF BRICK OVER THE OPENING.  
 - ALL LINTELS SHALL BE LONG LEG VERTICAL.  
 - WHEN SUPPORTING VEENER < 3" WIDE THE EXTERIOR TOE OF THE HORIZONTAL LEG MAY BE CUT IN THE FIELD TO BE 3/4" WIDE OVER THE BEARING LENGTH ONLY. THIS IS TO ALLOW FOR MORTAR JOINT FINISHING.  
 - SEE STRUCTURAL PLANS FOR ANY LINTEL CONDITION NOT ENCOMPASSED BY THE ABOVE PARAMETERS.  
 - FOR GREEN VEENER USE L4x6W.  
 - FOR 3 1/2" VEENER ONLY. SEE PLAN FOR VEENER SUPPORT IF VEENER < 3 1/2" THICK.

### LEGEND

- ▬ INTERIOR BEARING WALL
- ▬ BEARING WALL ABOVE
- ▬ BEAM / HEADER
- ▬ INDICATES SHEAR WALL & EXTENT
- ▬ EXTENT OF OVERFRAMING
- JL METAL HANGER
  - INDICATES POST ABOVE. PROVIDE SOLID BLOCKING UNDER POST OR JAMB ABOVE.
  - INDICATES HOLD-DOWN OR STRAP. REFER TO SCHEDULE.

### NON-BEARING HEADER SCHEDULE

SPAN	2x4 NON-BEARING PARTITION WALL	2x6 NON-BEARING PARTITION WALL
UP TO 3'-0"	(1)2x4 FLAT	(1)2x6 FLAT
UP TO 6'-0"	(2)2x4	(3)2x4
UP TO 8'-0"	(2)2x6	(3)2x6

NOTES:  
 • ALL NON-BEARING INTERIOR STUD WALLS SHALL BE CONSTRUCTED WITH 2x "STUD" GRADE MEMBERS SPACED @ 24" O.C. (MAX.)

### LATERAL BRACING & SHEAR WALL SHEATHING SPECIFICATIONS

THIS MODEL HAS BEEN DESIGNED TO RESIST LATERAL FORCES RESULTING FROM:  
**120 MPH WIND IN 2018 NCSEBC:RC**  
 (120 MPH WIND SPEED IN ASCE 7-10 WIND MAP, PER IRC R301.2.1.1) EXP. B, RISK CAT. 2 & SEISMIC CAT. A/B.

THE DESIGN WAS COMPLETED PER 2015 IBC (SECTION 1604) & ASCE 7-10, AS PERMITTED BY R301.1.3 OF THE 2018 NCSEBC:RC, OR THE SIMPLIFIED PRESCRIPTIVE PROCEDURE IN ACCORDANCE WITH THE 2015 IRC IF THE PARAMETERS OF SECTION R602.12 COMPLY. ACCORDINGLY, THIS MODEL, AS DOCUMENTED AND DETAILED HEREIN, IS ADEQUATE TO RESIST THE CODE REQUIRED LATERAL FORCES.

DESIGN WIND UPLIFT LOADS HAVE BEEN CALCULATED UTILIZING ASCE 7-10 (ACCEPTED ENGINEERING PRACTICE) AS ALLOWED PER 2018 NCSEBC:RC SECTION R802.1.1.1. THIS MODEL HAS BEEN DETAILED WHERE REQUIRED & ENGINEERED TO RESIST THE WIND UPLIFT LOAD PATH PER SECTIONS R602.3.5 & R802.11.

### EXT. WALL SHEATHING SPECIFICATION

- 7/16" OSB OR 15/32" PLYWOOD: FASTEN SHEATHING W/ 8d NAILS @ 6" O.C. AT EDGES & @ 12" O.C. IN THE PANEL FIELD. TYP. UNO.
- HORIZONTAL BLOCKING OF EXT. WALLS/SHEAR WALL PANEL EDGES IS NOT REQUIRED BY THIS DESIGN EXCEPT FOR THOSE AREAS SPECIFICALLY NOTED.
- ALL EXT. WALLS SHALL BE CONTINUOUSLY SHEATHED AND ARE CONSIDERED SHEAR WALLS.
- ALT. STAPLE CONNECTION SPEC: 1 1/2" 16 GA STAPLES (1/8" CROWN) @ 3" O.C. AT EDGES & @ 6" O.C. IN FIELD.

### BLOCKED PANEL EDGES

- AT DESIGNATED AREAS - FASTEN SHEATHING W/ 8d NAILS @ 6" O.C. AT ALL PANEL EDGES AND 12" O.C. IN THE PANEL FIELD OR 1 3/4" 16 GA STAPLES (1/8" CROWN) @ 3" O.C. AT EDGES & @ 6" O.C. IN FIELD. ALL SHEATHING PANELS SHALL BE ORIENTED AND INSTALLED FULL HEIGHT OF SHEAR WALL OR 2x HORIZONTAL BLOCKING SHALL BE PROVIDED TO SUPPORT ALL UNSUPPORTED PANEL EDGES & EDGE FASTENINGS.

### 3" O.C. EDGE NAILING

- AT DESIGNATED AREAS - FASTEN PANEL EDGES OF WOOD STRUCTURAL WALL SHEATHING TO FRAMING W/ 8d NAILS @ 3" O.C. NO STAPLE ALTERNATIVE AVAILABLE AT THIS SPEC. ALL SHEATHING PANELS SHALL BE ORIENTED AND INSTALLED FULL HEIGHT OF SHEAR WALL OR 2x HORIZONTAL BLOCKING SHALL BE PROVIDED TO SUPPORT UNSUPPORTED PANEL EDGES AND 3" O.C. EDGE FASTENING.

### NOTES

- SEE CONNECTION SPECIFICATIONS CHART FOR STANDARD SHEAR TRANSFER DETAILING. IF ADDITIONAL CAPACITY IS REQUIRED BY DESIGN, IT WILL BE SPECIFICALLY NOTED ON PLAN.
- DESIGN ASSUMES 16" O.C. MAX. STUD SPACING, UNO.
- ALL STRUCTURAL PANELS ARE TO BE DIRECTLY APPLIED TO STUD FRAMING.
- PRE-MANUFACTURED PANELIZED WALLS: FASTEN TOGETHER END STUDS OF WALL PANELS SHEATHED W/ OSB OR PLYWOOD W/ 10d NAILS @ 4" O.C. (THRU ONE SIDE ONLY)

- ▬ INDICATES EXTENT OF INT. OSB SHEARWALL OR 3" O.C. OSB SHEARWALL.
- ▶ INDICATES HOLDDOWN BELOW

### FLOOR FRAMING

- I-JOISTS/TRUSSES SHALL BE DESIGNED BY MANUF. TO MEET OR EXCEED L/480 LIVE LOAD DEFLECTION CRITERIA. (EXCLUDES MARBLE FLOORS - CONTACT MK FOR MARBLE FLOOR DESIGNS)
- AT I-JOIST FLOORS, PROVIDE 1 1/8" MIN. OSB RIM BOARD.
- METAL HANGERS SHALL BE SPECIFIED BY MANUFACTURER, UNO.
- I-JOIST/TRUSS SHOP DWGS. SHALL BE SUBMITTED TO ARCH. & ENG. FOR REVIEW AND APPROVAL PRIOR TO FABRICATION OR DELIVERY.
- FLOOR SHEATHING SHALL BE 23/32" A.P.A. RATED STURD-I-FLOOR' 24" O.C. EXPOSURE 1 (OR APPROVED EQUAL) WITH TONGUE AND GROOVE EDGES. FASTEN TO FRAMING MEMBERS W/ GLUE AND - 2 1/2" x 0.131" NAILS @ 6" O.C. @ PANEL EDGES & @ 12" O.C. FIELD. - 2 3/8" x 0.120" NAILS @ 4" O.C. @ PANEL EDGES & @ 8" O.C. FIELD. - 2 3/8" x 0.113" NAILS @ 3" O.C. @ PANEL EDGES & @ 6" O.C. IN FIELD.

### ROOF FRAMING

- BAY WINDOWS & SHED ROOFS (UP TO 6' SPAN) CAN BE 2x4 OR 2x6 RAFTERS & CEILING JOISTS @ 16/24" O.C.
- FASTEN EACH ROOF TRUSS TO TOP PLATE W/ SIMPSON H25T CLIP (OR APPROVED EQUAL) @ ALL BEARING POINTS. PROVIDE (2) H25T CLIPS AT 2-PLY GIRDER TRUSSES, (3) H25T CLIPS AT 3-PLY GIRDER TRUSSES & ROOF BEAMS - AT ALL BEARING POINTS.
- METAL HANGERS SHALL BE SPECIFIED BY THE MANUFACTURER, UNO.
- ROOF TRUSS SHOP DWGS. SHALL BE SUBMITTED TO ARCH & ENG. FOR REVIEW AND APPROVAL PRIOR TO FABRICATION OR DELIVERY.
- ERECT AND INSTALL ROOF TRUSSES PER WTGA & TPI'S BCSI I-08 "GUIDE TO GOOD PRACTICE FOR HANDLING, INSTALLING & BRACING OF METAL PLATE CONNECTED WOOD TRUSSES."
- SUPPORT PORCH & SHORT SPAN ROOF TRUSSES W/ 2x4 LEDGER FASTENED TO FRAMING W/ (2) 3"x0.131" NAILS @ 16" O.C. (MAX 7' SPAN).
- ROOF SHEATHING SHALL BE 7/16" A.P.A. RATED SHEATHING 24/16 EXPOSURE 1 (OR APPROVED EQUAL). FASTEN TO FRAMING MEMBERS - W/ 2 1/2" x 0.131" NAILS @ 6" O.C. @ PANEL EDGES & @ 12" O.C. FIELD. - W/ 2 3/8" x 0.120" NAILS @ 4" O.C. @ PANEL EDGES & @ 8" O.C. FIELD. - W/ 2 3/8" x 0.113" NAILS @ 3" O.C. @ PANEL EDGES & @ 6" O.C. FIELD.

### GENERAL STRUCTURAL NOTES

- DESIGN IS BASED ON 2018 NORTH CAROLINA STATE BUILDING CODE: RESIDENTIAL CODE.
- WOOD FRAME ENGINEERING IS BASED ON NDS, "NATIONAL DESIGN SPECIFICATION FOR WOOD CONSTRUCTION" - LATEST EDITION.
- DESIGN LOADS:
  - ROOF DEAD = 7 PSF T.C., 10 PSF B.G. LIVE = 16 PSF LOAD DURATION FACTOR = 1.25
  - FLOOR LIVE = 40 PSF @ SLEEPING AREAS) DEAD = 10 PSF (I-JOISTS & SOLID SAHN) 10 PSF T.C., 5 PSF B.G. (TRUSSES) (ADD'L 10 PSF @ TILE)
  - LATERAL 120 MPH, EXPOSURE B. SEISMIC A/B.
  - SOIL 2,000 PSF ASSUMED ALLOWABLE BEARING PRESSURE (TO BE VERIFIED BY BUILDER)

### GENERAL FRAMING

- ALL TYP. NAIL FASTENER REQUIREMENTS ARE NOTED IN STANDARD CONNECTIONS TABLE OR ON PLANS. ALL NAILS SPECIFIED ARE MIN DIAMETER AND LENGTH REQUIRED FOR CONNECTION. ALL HANGER NAILS SHALL BE INSTALLED PER MANUFACTURER'S REQUIREMENTS FOR MAX CHARTED CAPACITY. NOTE: HANGERS USE COMMON NAIL DIAMETERS NOT TYPICAL FRAMING GUN NAILS.
- REFER TO FASTENING SCHEDULE TABLE R602.3(1) FOR ALL CONNECTIONS, TYP. UNO.
- EXT. & INT. BRG WALLS SHALL BE 2x4 OR 2x6 (AS SHOWN ON PLANS) @ 16" O.C. SFF OR SYP "STUD" GRADE LUMBER, OR BETTER, UNO.
  - WALLS OVER 12' TALL SHALL BE PER PLAN.
- ALL HEADERS, BEAMS & OTHER STRUCTURAL MEMBERS SHALL BE SPRUCE-PINE-FIR #2 (SFF) OR SOUTHERN PINE #2 (SYP) LUMBER, OR BETTER (KILN-DRIED). ALL HEADERS HAVE BEEN DESIGNED BASED ON CALCULATED LOADS & SIZED ACCORDINGLY. CODE TABLES HAVE NOT BEEN USED.
- ALL NON-BEARING INTERIOR STUD WALLS SHALL BE CONSTRUCTED WITH 2x "STUD" GRADE MEMBERS SPACED @ 16" O.C. (MAX, UNO.)
  - HEADERS IN NON-LOAD BEARING WALLS SHALL BE: (1)2x4/6 FLAT @ OPENINGS UP TO 4'; (2)2x4/6 FLAT UP TO 8'.
- ALL FRAMING LUMBER SHALL BE DRIED TO 15% MC (KD-15).
- ENGINEERED LUMBER TO MEET OR EXCEED THE FOLLOWING:
  - LVL - Fb=2325 psi; Fv=310 psi; E=1.55x10<sup>6</sup> psi
  - LVL - Fb=2600 psi; Fv=285 psi; E=2.0x10<sup>6</sup> psi
- FOR 2 & 3 PLY BEAMS OF EQUAL WIDTH, FASTEN PLIES TOGETHER WITH 3 ROWS OF 3"x0.120" NAILS @ 8" O.C. OR 2 ROWS 1/4"x3/8" SIMPSON SDS SCREENS (OR 3/8" TRUSSLOK SCREENS) @ 16" O.C. USE A MINIMUM OF 3 ROWS FOR BEAM DEPTHS OF 14" OR GREATER. APPLY FASTENING AT BOTH FACES FOR 3-PLY CONDITION. LOCATE TOP & BOTTOM NAILS/SCREENS 2" FROM EDGE. SOLID 3 1/2" OR 5 1/4" BEAMS ARE ACCEPTABLE. USE 2 ROWS OF NAILS FOR 2x6 & 2x8 MEMBERS.
- FOR 4 PLY BEAMS OF EQUAL WIDTH, FASTEN PLIES TOGETHER WITH 3 ROWS OF 1/4"x6" SIMPSON SDS SCREENS (OR 6 3/4" TRUSSLOK SCREENS) @ 16" O.C. USE A MINIMUM OF 4 ROWS FOR BEAM DEPTHS OF 14" OR GREATER. APPLY FASTENING AT BOTH FACES (ONE SIDE ONLY FOR TRUSSLOK SCREENS). LOCATE TOP AND BOTTOM SCREENS 2" FROM EDGE. A SOLID 7" BEAM IS ACCEPTABLE.
- ALL HEADERS SHALL BE SUPPORTED BY (1)2x JACK STUD @ (1)2x KING STUD, MINIMUM.
  - THE NUMBER OF STUDS SPECIFIED AT A SUPPORT INDICATES THE NUMBER OF JACK STUDS REQUIRED, UNO..
- ALL MULTI-PLY STUDS TO BE FASTENED TOGETHER W/ 3"x0.131" NAILS @ 24" O.C. (MIN), EACH PLY.
- PROVIDE SOLID BLOCKING IN FLOOR SYSTEM UNDER ALL POSTS CONTINUOUS TO FND/BEARING. BLOCKING TO MATCH POST ABOVE.
- FASTEN 2x WOOD PLATES TO TOP FLANGE OF STEEL BEAMS WITH P.A.F.'s (HILTI' X-CF PINS OR EQUAL) @ 16" O.C. STAGGERED, OR 1/2" DIA. BOLTS @ 48" O.C. STAGGERED.
- ALL EXTERIOR 4x4 WOOD POSTS SHALL HAVE SIMPSON BC52-2/4 CAP & ABW44Z BASE, UNO.

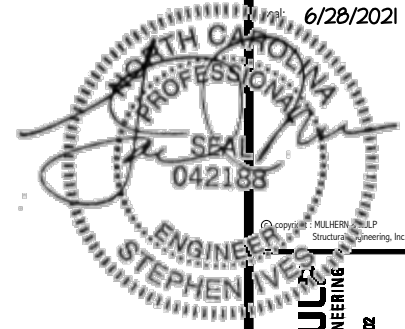

M&K project number:  
126-21020  
project mgr: JTR  
drawn by: KL  
issue date: 06-12-21

REVISIONS:  
date: initial:



FOUNDATION PLANS  
DRAYTON  
RALEIGH, NC

sheet: LEFT HAND

S1.0

**LEGEND**

- ▬ INTERIOR BEARING WALL
- - - BEARING WALL ABOVE
- ▬ BEAM / HEADER
- ▬ INDICATES SHEAR WALL & EXTENT
- ▬ EXTENT OF OVERFRAMING
- ⌋L METAL HANGER
- \* INDICATES POST ABOVE. PROVIDE SOLID BLOCKING UNDER POST OR JAMB ABOVE.
- ▴ INDICATES HOLD-DOWN OR STRAP. REFER TO SCHEDULE.

REFER TO S.O. FOR  
TYPICAL STRUCTURAL NOTES  
& SCHEDULES

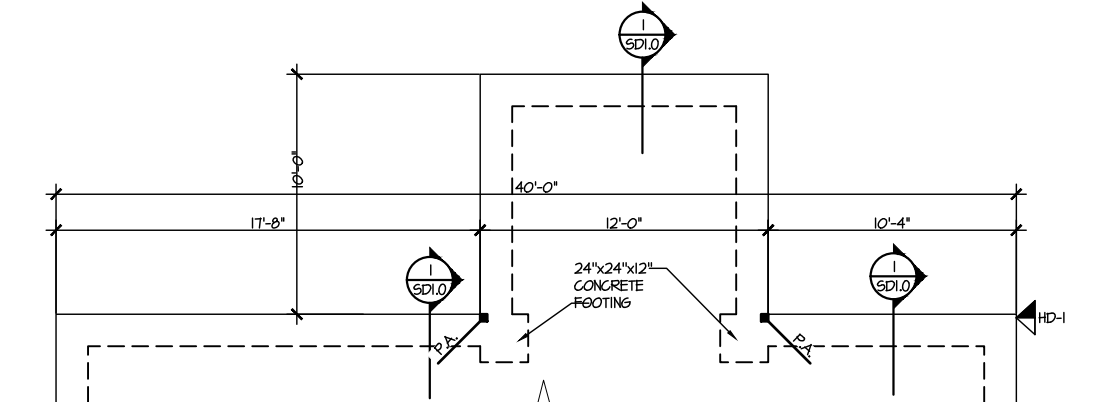

3 PARTIAL MONO SLAB FOUNDATION PLAN  
SCALE: 1/8"=1'-0"  
OPTIONAL EXT. BREAKFAST

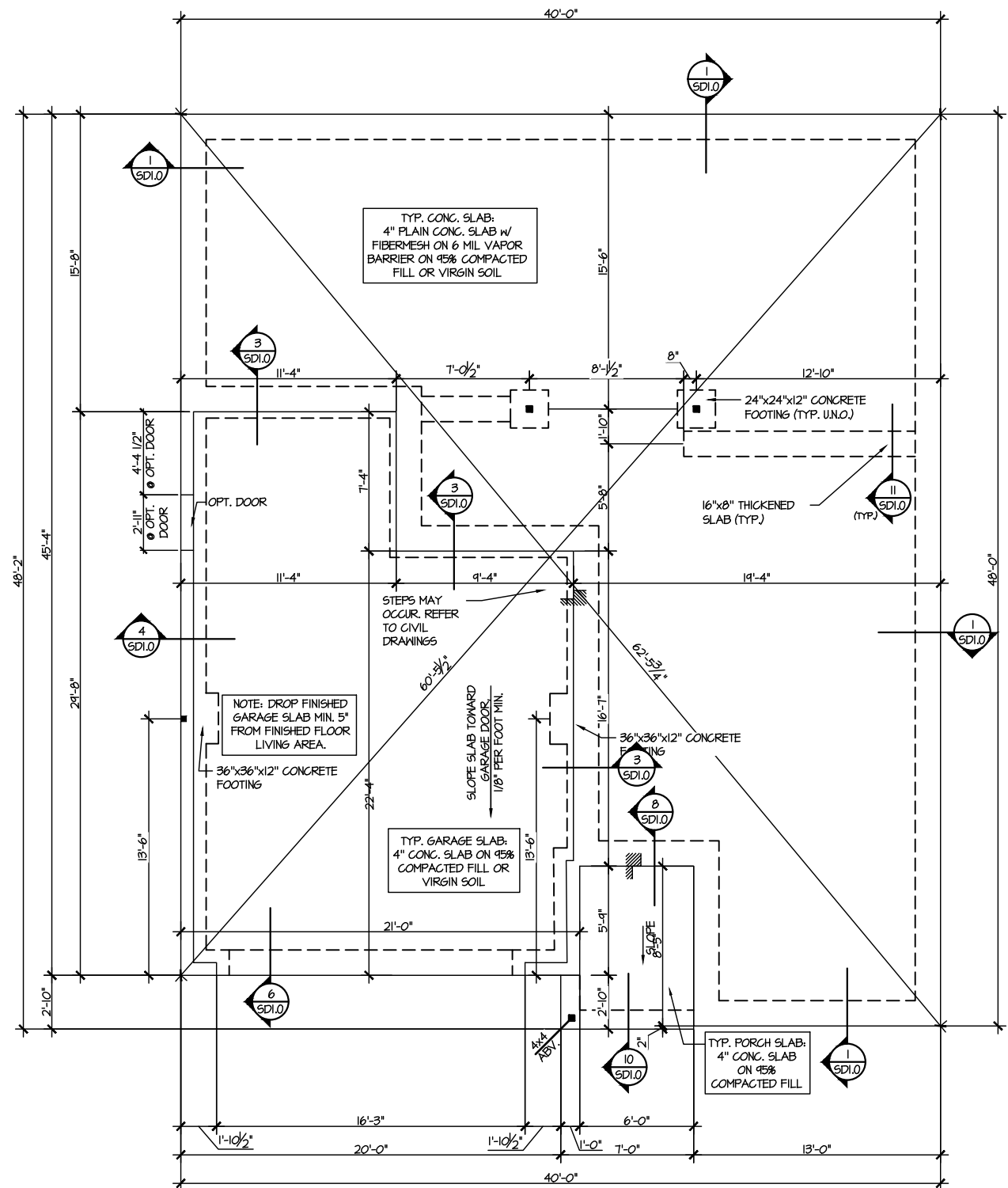

1 MONO SLAB FOUNDATION PLAN  
SCALE: 1/8"=1'-0"  
ELEVATION #1



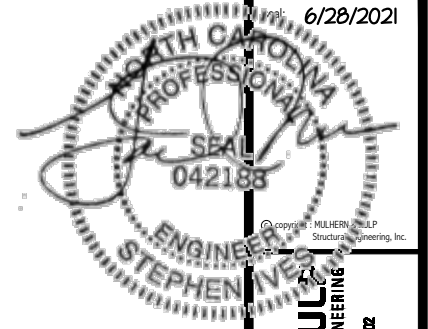

MULHERN+KUL  
RESIDENTIAL STRUCTURAL ENGINEERING  
300 Riverside Ave., Building 4 - Asheville, PA 18002  
P 215-646-8071 - mulhernmkp.com  
N.C. LIC # 65382

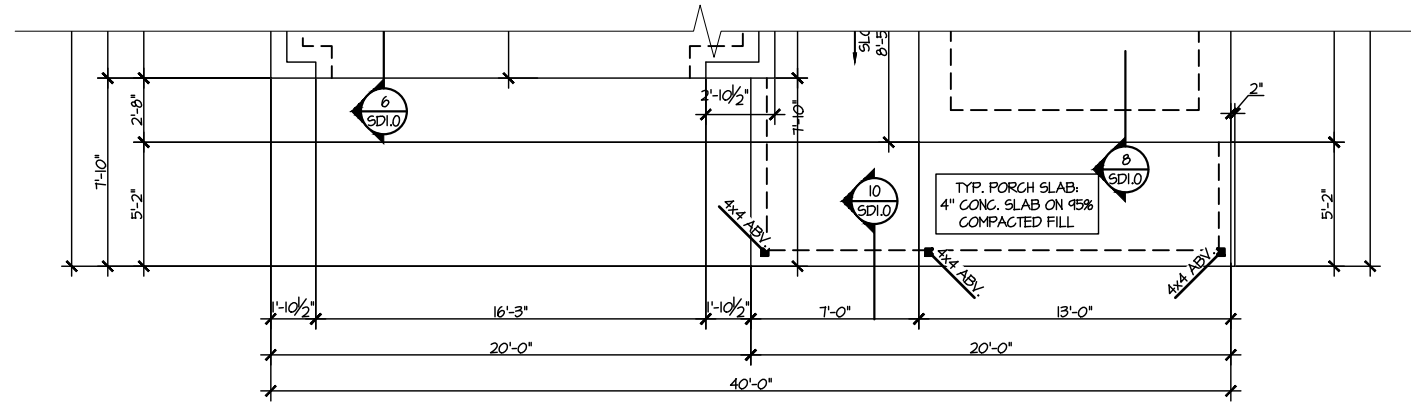

**2 PARTIAL MONO SLAB FOUNDATION PLAN**  
SCALE: 1/8"=1'-0" ELEVATION #3

LEGEND	
	INTERIOR BEARING WALL
	BEARING WALL ABOVE
	BEAM / HEADER
	INDICATES SHEAR WALL & EXTENT
	EXTENT OF OVERFRAMING
	M METAL HANGER
	* INDICATES POST ABOVE. PROVIDE SOLID BLOCKING UNDER POST OR JAMB ABOVE.
	▶ INDICATES HOLD-DOWN OR STRAP. REFER TO SCHEDULE.

**REFER TO 50.0 FOR  
TYPICAL STRUCTURAL NOTES  
& SCHEDULES**

M&K project number:  
126-21020  
project mgr: JTR  
drawn by: KL  
issue date: 06-12-21

REVISIONS:	
date:	initial:



FOUNDATION PLANS  
DRAYTON  
RALEIGH, NC

sheet: LEFT HAND  
**S1.1**

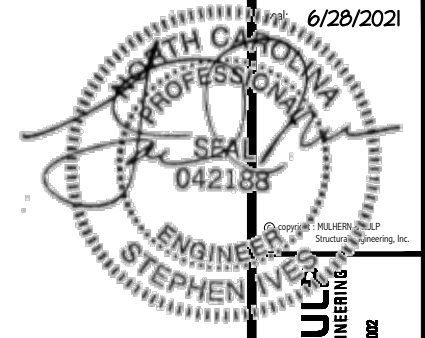

**MULHERN+KUL**  
RESIDENTIAL STRUCTURAL ENGINEERING  
300 Remicade Ave. Building 4 - Anahier, PA 18002  
P 215-648-8001 - mulhernmkp.com  
I.C.E. #F33823



M&K project number:  
**126-21020**  
project mgr: JTR  
drawn by: KL  
issue date: 06-12-21

REVISIONS:  
date: initial:



OPTION FRAMING PLANS  
**DRAYTON**  
RALEIGH, NC

sheet: LEFT HAND

**S5.4**

REFER TO 50.0 FOR  
TYPICAL STRUCTURAL NOTES  
& SCHEDULES

LEGEND	
• [dashed box]	INTERIOR BEARING WALL
• [dotted box]	BEARING WALL ABOVE
• [solid line]	BEAM / HEADER
• [thick dashed line]	INDICATES SHEAR WALL & EXTENT
• [stippled box]	EXTENT OF OVERFRAMING
• [triangle]	METAL HANGER
• [asterisk]	INDICATES POST ABOVE. PROVIDE SOLID BLOCKING UNDER POST OR JAMB ABOVE.
• [inverted triangle]	INDICATES HOLD-DOWN OR STRAP. REFER TO SCHEDULE.

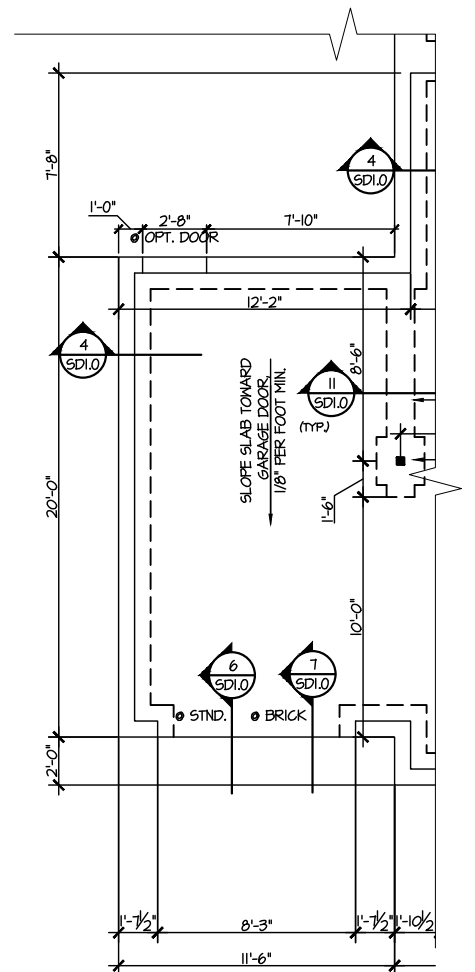

**PARTIAL MONOSLAB FOUNDATION PLAN  
OPTIONAL 3RD CAR GARAGE**  
SCALE: 1/8"=1'-0" ELEV. #1 SHOWN - ALL ELEV. SIM.

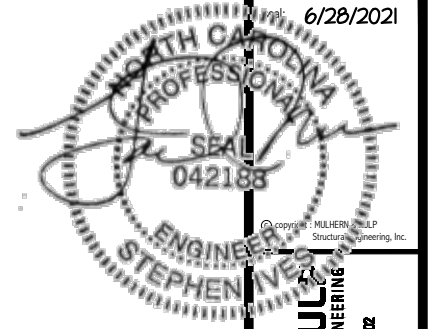

**MULHERN+KULL**  
RESIDENTIAL STRUCTURAL ENGINEERING  
300 Riverside Ave., Building 4 - Aunim, PA 18002  
P 215-646-8071 - mulhern+kull.com  
N.C.L.C. #5382



MXK project number:  
**126-21020**  
project mgr: **JTR**  
drawn by: **KL**  
issue date: **06-12-21**

REVISIONS:  
date: initial:



**FLOOR FRAMING PLANS**  
**DRAYTON**  
RALEIGH, NC

sheet: **LEFT HAND**  
**S3.0J**

REFER TO S.O. FOR  
TYPICAL STRUCTURAL NOTES  
& SCHEDULES

SD2.0 & SD2.1 REFERS TO SD2.0J  
& SD2.1J FOR I-JOIST FLOOR  
FRAMING OR SD2.0T & SD2.1T  
FOR TRUSS FLOOR FRAMING

SD2.1J/SD2.1T REFERS TO  
SD2.1JA/SD2.1TA FOR LVL/PSL/LSL  
BEAMS OR SD2.1JB/SD2.1TB FOR  
FLITCH BEAMS OR  
SD2.1JC/SD2.1TC FOR STEEL  
BEAMS

**LEGEND**

- ◻ INTERIOR BEARING WALL
- ◻ BEARING WALL ABOVE
- BEAM / HEADER
- - - INDICATES SHEAR WALL & EXTENT
- ◻ EXTENT OF OVERFRAMING
- J.L. METAL HANGER
- \* INDICATES POST ABOVE. PROVIDE SOLID BLOCKING UNDER POST OR JAMB ABOVE.
- ▶ INDICATES HOLD-DOWN OR STRAP. REFER TO SCHEDULE.

**ENGINEERED BEAM MATERIAL SCHEDULE**

BEAM NUMBER	LVL OPTION	PSL OPTION	LSL OPTION	FLITCH OPTION	STEEL OPTION
001	(2)3/4"x14" - F	3/2"x14" - F	(2)3/4"x14" - F	(2)2x12 + (1)1/4"x14" STEEL FLITCH PLATES - FB	W12x14 - F
002	(2)3/4"x14" - F	3/2"x14" - F	(2)3/4"x14" - F	(2)2x12 + (1)1/4"x14" STEEL FLITCH PLATES - FB	W12x14 - F
003	(3)3/4"x18" - FB or (2)3/4"x20" - FB	5/4"x18" - FB	N/A	(3)2x12 + (2)3/4"x14" STEEL FLITCH PLATES - FB	W12x26 - F
004	(2)3/4"x14" - F	3/2"x14" - F	(2)3/4"x14" - F	(2)2x12 + (1)1/4"x14" STEEL FLITCH PLATES - FB	W12x14 - F
005	(2)3/4"x11 1/2" - H cont.	3/2"x11 1/2" - H cont.	(2)3/4"x11 1/2" - H cont.	(3)2x12 + (2)3/4"x14" STEEL FLITCH PLATES - H cont.	N/A
005A	(3)3/4"x14" - H cont.	5/4"x14" - H cont.	N/A	(3)2x12 + (2)3/4"x14" STEEL FLITCH PLATES - H cont.	N/A
006	(1)3/4"x14" - F	3/2"x14" - F	(2)3/4"x14" - F	(2)2x12 + (1)1/4"x14" STEEL FLITCH PLATES - FB	W12x14 - F
007	(2)3/4"x11 1/2" - D	3/2"x11 1/2" - D	(2)3/4"x11 1/2" - D	(2)2x12 + (1)1/4"x14" STEEL FLITCH PLATES - D	W10x12 - D
008	(2)3/4"x16" - H cont.	3/2"x16" - H cont.	(3)3/4"x16" - H cont.	(2)2x12 + (2)3/4"x14" STEEL FLITCH PLATES - H cont.	N/A
009	(2)3/4"x14" - F	3/2"x14" - F	(2)3/4"x14" - F	(2)2x12 + (1)1/4"x14" STEEL FLITCH PLATES - F	W8x10 - F
010	(2)3/4"x14" - F	3/2"x14" - F	(2)3/4"x14" - F	(2)2x12 + (1)1/4"x14" STEEL FLITCH PLATES - FB	W12x14 - F
011	(2)3/4"x14" - F	3/2"x14" - F	(2)3/4"x14" - F	(2)2x12 + (1)1/4"x14" STEEL FLITCH PLATES - FB	W12x14 - F
012	(2)3/4"x11 1/2" - D	3/2"x11 1/2" - D	(2)3/4"x11 1/2" - D	(2)2x12 + (1)1/4"x14" STEEL FLITCH PLATES - D	W10x12 - D

**BEAM NOTATION:**

- "F" INDICATES FLUSH BEAM
- "FT" INDICATES FLUSH TOP BEAM
- "FB" INDICATES FLUSH BOTTOM BEAM
- "D" INDICATES DROPPED BEAM
- "H" INDICATES DROPPED OPENING HEADER

REFER TO DETAIL D/SD2.0 FOR TYPICAL FLITCH BEAM CONNECTIONS  
REFER TO DETAIL E/SD2.0 FOR TYPICAL STEEL BEAM CONNECTIONS  
FOR FLUSH TOP BEAMS PROVIDE 2X STACKED PLATES BENEATH BEAM AS REQ'D. FASTEN PLATES IN SUCCESSION W/ (2) 3"x0.120" NAILS @ 8" O.C.  
FOR FLUSH BOTTOM BEAMS PROVIDE 2X STACKED PLATES ATOP BEAM AS REQ'D. FASTEN PLATES IN SUCCESSION W/ (2) 3"x0.120" NAILS @ 8" O.C.

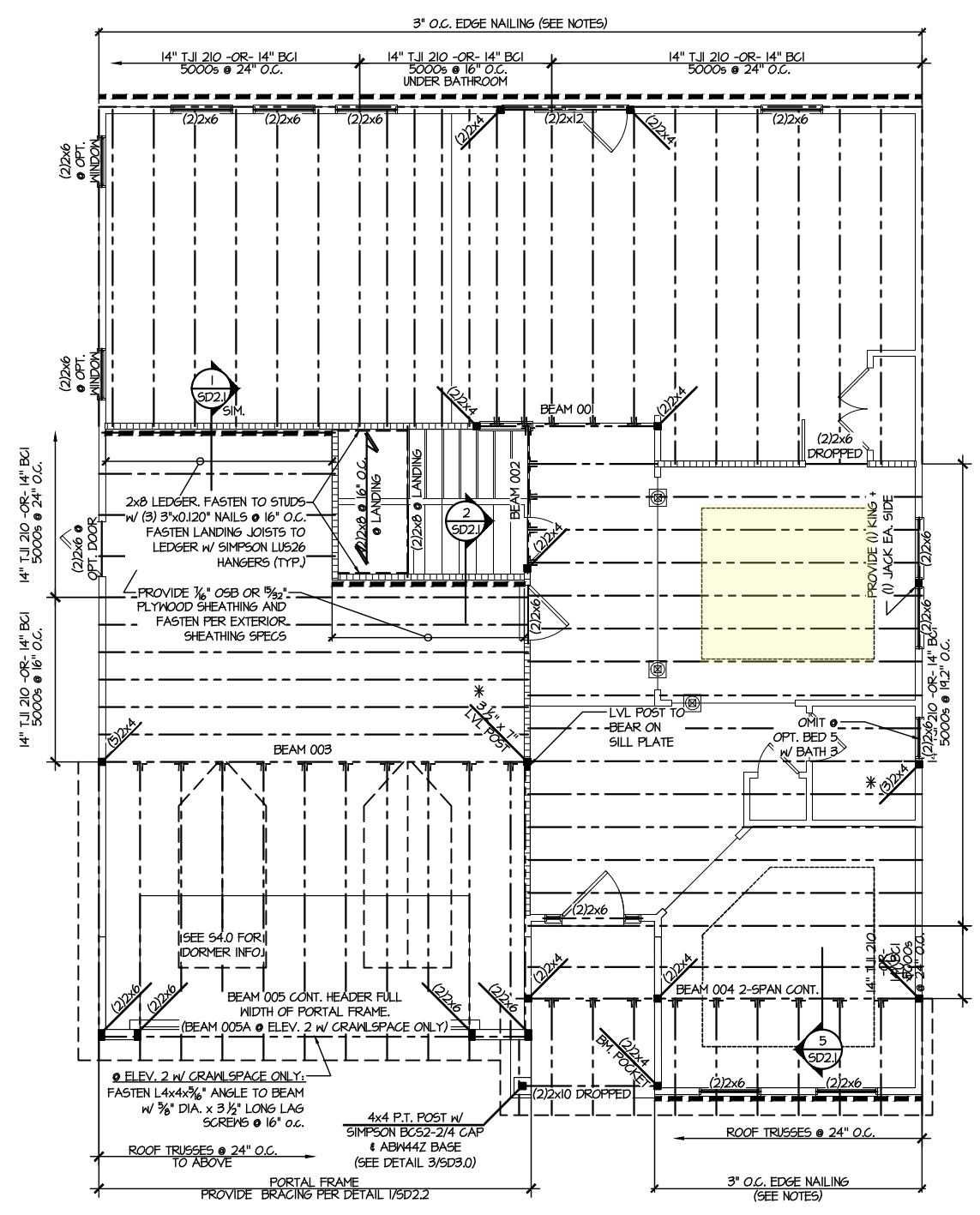

**1 2ND FLOOR FRAMING PLAN**  
SCALE: 1/8"=1'-0"  
ELEVATIONS #1 & #2

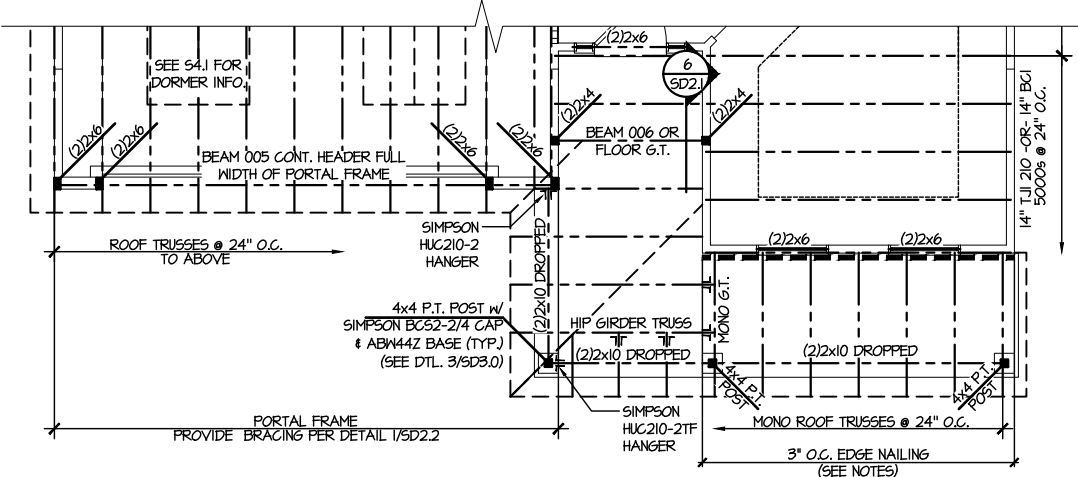

**2 PARTIAL 2ND FLOOR FRAMING PLAN**  
SCALE: 1/8"=1'-0"  
ELEVATION #3

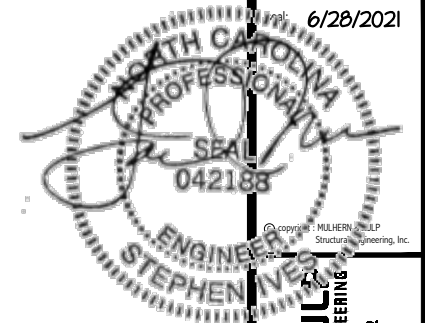

**MULHERN+KUL**  
RESIDENTIAL STRUCTURAL ENGINEERING  
300 Brookside Ave. Building 4 - Asheville, PA 18002  
P 215-448-8001 - mulhernpk.com  
N.C. REG. #3525

**LEGEND**

- ▬ INTERIOR BEARING WALL
- ▬ BEARING WALL ABOVE
- ▬ BEAM / HEADER
- ▬ INDICATES SHEAR WALL & EXTENT
- ▬ EXTENT OF OVERFRAMING
- JL METAL HANGER
- \* INDICATES POST ABOVE. PROVIDE SOLID BLOCKING UNDER POST OR JAMB ABOVE.
- ▶ INDICATES HOLD-DOWN OR STRAP. REFER TO SCHEDULE.

REFER TO 50.0 FOR TYPICAL STRUCTURAL NOTES & SCHEDULES

SD2.0 & SD2.1 REFERS TO SD2.0J & SD2.1J FOR I-JOIST FLOOR FRAMING OR SD2.0T & SD2.1T FOR TRUSS FLOOR FRAMING

SD2.1J/SD2.1T REFERS TO SD2.1JA/SD2.1TA FOR LVL/PSL/LSL BEAMS OR SD2.1JB/SD2.1TB FOR FLITCH BEAMS OR SD2.1JC/SD2.1TC FOR STEEL BEAMS

**ENGINEERED BEAM MATERIAL SCHEDULE**

BEAM NUMBER	LVL OPTION	PSL OPTION	LSL OPTION	FLITCH OPTION	STEEL OPTION
001	(2)3/4"x14" - F	3/2"x14" - F	(2)3/4"x14" - F	(2)2x12 + (1)1/2"x14" STEEL FLITCH PLATES - FB	M2x14 - F
002	(2)3/4"x14" - F	3/2"x14" - F	(2)3/4"x14" - F	(2)2x12 + (1)1/2"x14" STEEL FLITCH PLATES - FB	M2x14 - F
003	(3)3/4"x18" - FB or (2)3/4"x20" - FB	5/4"x18" - FB	N/A	(3)2x12 + (2)3/4"x14" STEEL FLITCH PLATES - FB	M2x26 - F
004	(2)3/4"x14" - F	3/2"x14" - F	(2)3/4"x14" - F	(2)2x12 + (2)3/4"x14" STEEL FLITCH PLATES - FB	M2x14 - F
005	(2)3/4"x11 1/2" - H cont.	3/2"x11 1/2" - H cont.	(2)3/4"x11 1/2" - H cont.	(3)2x12 + (2)3/4"x11 1/2" STEEL FLITCH PLATES - H cont.	N/A
005A	(3)3/4"x14" - H cont.	5/4"x14" - H cont.	N/A	(3)2x12 + (2)3/4"x14" STEEL FLITCH PLATES - H cont.	N/A
006	(1)3/4"x14" - F	3/2"x14" - F	(2)3/4"x14" - F	(2)2x12 + (1)1/2"x14" STEEL FLITCH PLATES - FB	M2x14 - F
007	(2)3/4"x11 1/2" - D	3/2"x11 1/2" - D	(2)3/4"x11 1/2" - D	(2)2x12 + (1)1/2"x14" STEEL FLITCH PLATES - D	M10x12 - D
008	(2)3/4"x16" - H cont.	3/2"x16" - H cont.	(3)3/4"x16" - H cont.	(3)2x12 + (2)3/4"x14" STEEL FLITCH PLATES - H cont.	N/A
004	(2)3/4"x9 1/4" - F	3/2"x9 1/4" - F	(2)3/4"x9 1/4" - F	(2)2x10 + (1)1/2"x9 1/4" STEEL FLITCH PLATES - F	M8x10 - F
010	(2)3/4"x14" - F	3/2"x14" - F	(2)3/4"x14" - F	(2)2x12 + (1)1/2"x14" STEEL FLITCH PLATES - FB	M2x14 - F
011	(2)3/4"x14" - F	3/2"x14" - F	(2)3/4"x14" - F	(2)2x12 + (1)1/2"x14" STEEL FLITCH PLATES - FB	M2x14 - F
012	(2)3/4"x11 1/2" - D	3/2"x11 1/2" - D	(2)3/4"x11 1/2" - D	(2)2x12 + (1)1/2"x14" STEEL FLITCH PLATES - D	M10x12 - D

**BEAM NOTATION:**

- "F" INDICATES FLUSH BEAM
- "FT" INDICATES FLUSH TOP BEAM
- "FB" INDICATES FLUSH BOTTOM BEAM
- "D" INDICATES DROPPED BEAM
- "H" INDICATES DROPPED OPENING HEADER

• REFER TO DETAIL D/SD2.0 FOR TYPICAL FLITCH BEAM CONNECTIONS  
 • REFER TO DETAIL E/SD2.0 FOR TYPICAL STEEL BEAM CONNECTIONS  
 • FOR FLUSH TOP BEAMS PROVIDE 2X STACKED PLATES BENEATH BEAM AS REQ'D. FASTEN PLATES IN SUCCESSION W/ (2) 3"x0.120" NAILS @ 8" O.C.  
 • FOR FLUSH BOTTOM BEAMS PROVIDE 2X STACKED PLATES ATOP BEAM AS REQ'D. FASTEN PLATES IN SUCCESSION W/ (2) 3"x0.120" NAILS @ 8" O.C.

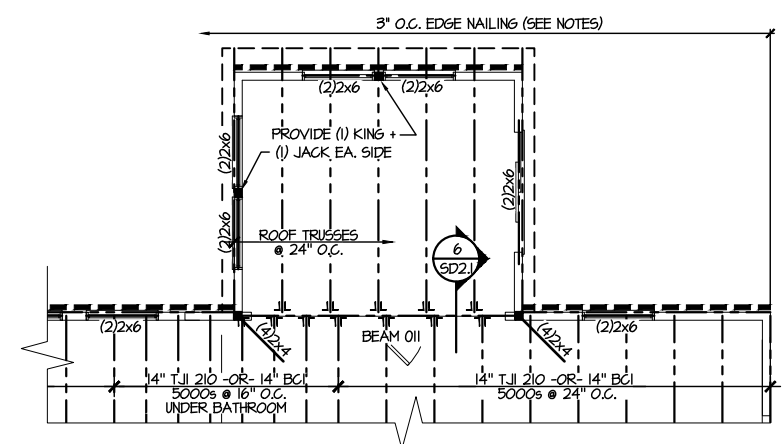

**5 PARTIAL SECOND FLOOR FRAMING PLAN**  
**OPTIONAL EXT. BREAKFAST**  
SCALE: 1/8"=1'-0" ELEV. #1 SHOWN - ALL ELEV. SIM.

M&K project number:  
**126-21020**

project mgr: JTR  
drawn by: KL  
issue date: 06-12-21

REVISIONS:  
date: initial:



OPTION FRAMING PLANS  
**DRAYTON**  
RALEIGH, NC

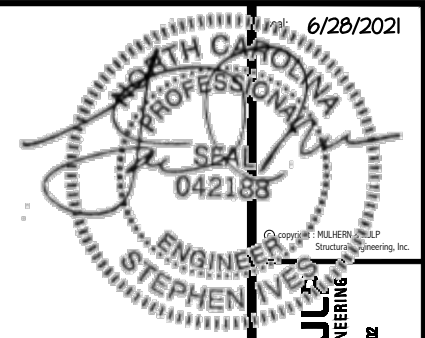

MULHERN+KUL...  
RESIDENTIAL STRUCTURAL ENGINEERING  
300 Brookside Ave. Building 4 - Ardener, PA 18002  
P 215-848-0001 F mulhernmk.com  
N.C. Lic. #C-3825

REFER TO S.O. FOR  
TYPICAL STRUCTURAL NOTES  
& SCHEDULES

SD2.0 & SD2.1 REFERS TO SD2.OJ  
& SD2.IJ FOR I-JOIST FLOOR  
FRAMING OR SD2.OT & SD2.IT  
FOR TRUSS FLOOR FRAMING

SD2.IJ/SD2.IT REFERS TO  
SD2.IJA/SD2.ITA FOR LVL/PSL/LSL  
BEAMS OR SD2.IJB/SD2.ITB FOR  
FLITCH BEAMS OR  
SD2.IJC/SD2.ITC FOR STEEL  
BEAMS

**LEGEND**

- [Symbol] INTERIOR BEARING WALL
- [Symbol] BEARING WALL ABOVE
- [Symbol] BEAM / HEADER
- [Symbol] INDICATES SHEAR WALL & EXTENT
- [Symbol] EXTENT OF OVERFRAMING
- JL METAL HANGER
- \* INDICATES POST ABOVE. PROVIDE SOLID BLOCKING UNDER POST OR JAMB ABOVE.
- ▶ INDICATES HOLD-DOWN OR STRAP. REFER TO SCHEDULE.

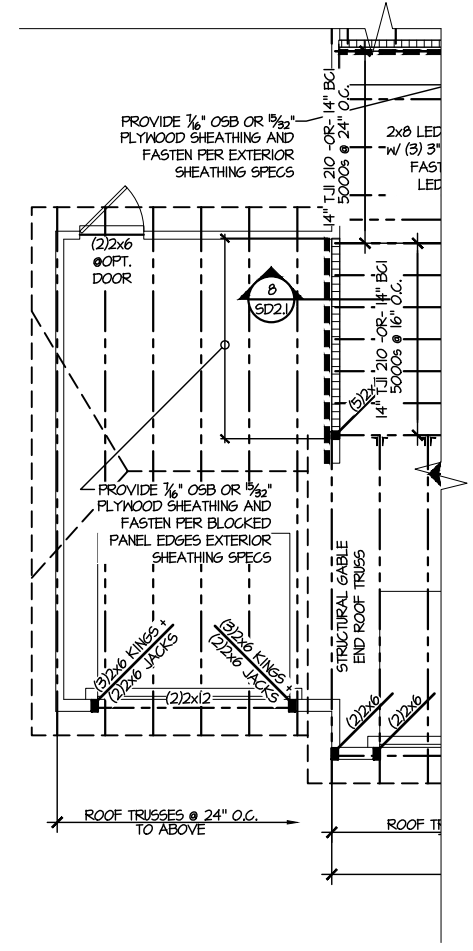

**PARTIAL SECOND FLOOR FRAMING PLAN  
OPTIONAL 3RD CAR GARAGE**  
SCALE: 1/8"=1'-0" ELEV. #1 SHOWN - ALL ELEVS. SIM.

M&K project number:  
126-21020  
project mgr: JTR  
drawn by: KL  
issue date: 06-12-21

REVISIONS:

date:	initial:

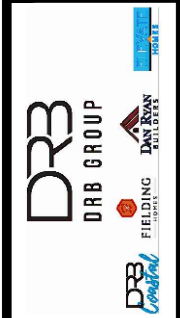

OPTION FRAMING PLANS  
DRAYTON  
RALEIGH, NC

sheet: LEFT HAND  
**S5.3J**



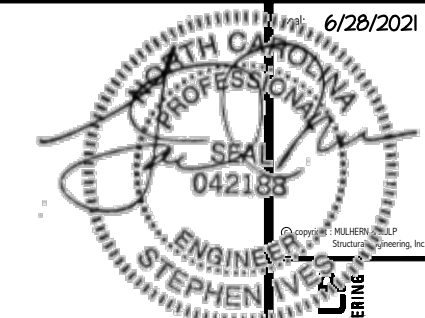

**MULHERN+KULL**  
RESIDENTIAL STRUCTURAL ENGINEERING  
300 Riverside Ave., Building 4 - Aunim, PA 18002  
P 215-646-8071 - mulhern+kull.com  
N.C.L.C. #5382



MRJ project number:  
**126-21020**  
project mgr: **JTR**  
drawn by: **KL**  
issue date: **06-12-21**

REVISIONS:  
date: initial:

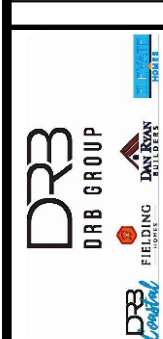

**FLOOR FRAMING PLANS**  
**DRAYTON**  
RALEIGH, NC

sheet: **LEFT HAND**  
**S3.0T**

REFER TO S.O.O FOR  
TYPICAL STRUCTURAL NOTES  
& SCHEDULES

SD2.0 & SD2.1 REFERS TO SD2.0J  
& SD2.1J FOR I-JOIST FLOOR  
FRAMING OR SD2.0T & SD2.1T  
FOR TRUSS FLOOR FRAMING

SD2.1J/SD2.1T REFERS TO  
SD2.1JA/SD2.1TA FOR LVL/PSL/LSL  
BEAMS OR SD2.1JB/SD2.1TB FOR  
FLITCH BEAMS OR  
SD2.1JC/SD2.1TC FOR STEEL  
BEAMS

**LEGEND**

- INTERIOR BEARING WALL
- BEARING WALL ABOVE
- BEAM / HEADER
- INDICATES SHEAR WALL & EXTENT
- EXTENT OF OVERFRAMING
- JL METAL HANGER
- \* INDICATES POST ABOVE. PROVIDE SOLID BLOCKING UNDER POST OR JAMB ABOVE.
- ▶ INDICATES HOLD-DOWN OR STRAP. REFER TO SCHEDULE.

**ENGINEERED BEAM MATERIAL SCHEDULE**

BEAM NUMBER	LVL OPTION	PSL OPTION	LSL OPTION	FLITCH OPTION	STEEL OPTION
001	(2)3/4"x14" - F	3/2"x14" - F	(2)3/4"x14" - F	(2)2x12 + (1)1/4"x14" STEEL FLITCH PLATES - FB	W12x14 - F
002	(2)3/4"x14" - F	3/2"x14" - F	(2)3/4"x14" - F	(2)2x12 + (1)1/4"x14" STEEL FLITCH PLATES - FB	W12x14 - F
003	(3)3/4"x18" - FB or (2)3/4"x20" - FB	5/4"x18" - FB	N/A	(3)2x12 + (2)3/4"x14" STEEL FLITCH PLATES - FB	W12x26 - F
004	(2)3/4"x14" - F	3/2"x14" - F	(2)3/4"x14" - F	(2)2x12 + (1)1/4"x14" STEEL FLITCH PLATES - FB	W12x14 - F
005	(2)3/4"x11 1/2" - H cont.	3/2"x11 1/2" - H cont.	(2)3/4"x11 1/2" - H cont.	(3)2x12 + (2)3/4"x11 1/2" STEEL FLITCH PLATES - H cont.	N/A
005A	(3)3/4"x14" - H cont.	5/4"x14" - H cont.	N/A	(3)2x12 + (2)3/4"x14" STEEL FLITCH PLATES - H cont.	N/A
006	(1)3/4"x14" - F	3/2"x14" - F	(2)3/4"x14" - F	(2)2x12 + (1)1/4"x14" STEEL FLITCH PLATES - FB	W12x14 - F
007	(2)3/4"x11 1/2" - D	3/2"x11 1/2" - D	(2)3/4"x11 1/2" - D	(2)2x12 + (1)1/4"x14" STEEL FLITCH PLATES - D	W10x12 - D
008	(2)3/4"x16" - H cont.	3/2"x16" - H cont.	(3)3/4"x16" - H cont.	(3)2x12 + (2)3/4"x14" STEEL FLITCH PLATES - H cont.	N/A
009	(2)3/4"x14" - F	3/2"x14" - F	(2)3/4"x14" - F	(2)2x12 + (1)1/4"x14" STEEL FLITCH PLATES - F	W8x10 - F
010	(2)3/4"x14" - F	3/2"x14" - F	(2)3/4"x14" - F	(2)2x12 + (1)1/4"x14" STEEL FLITCH PLATES - FB	W12x14 - F
011	(2)3/4"x14" - F	3/2"x14" - F	(2)3/4"x14" - F	(2)2x12 + (1)1/4"x14" STEEL FLITCH PLATES - FB	W12x14 - F
012	(2)3/4"x11 1/2" - D	3/2"x11 1/2" - D	(2)3/4"x11 1/2" - D	(2)2x12 + (1)1/4"x14" STEEL FLITCH PLATES - D	W10x12 - D

**BEAM NOTATION:**

- "F" INDICATES FLUSH BEAM
- "FT" INDICATES FLUSH TOP BEAM
- "FB" INDICATES FLUSH BOTTOM BEAM
- "D" INDICATES DROPPED BEAM
- "H" INDICATES DROPPED OPENING HEADER

REFER TO DETAIL D/SD2.0 FOR TYPICAL FLITCH BEAM CONNECTIONS  
REFER TO DETAIL E/SD2.0 FOR TYPICAL STEEL BEAM CONNECTIONS  
FOR FLUSH TOP BEAMS PROVIDE 2X STACKED PLATES BENEATH BEAM AS REQ'D. FASTEN PLATES IN SUCCESSION W/ (2) 3"x0.120" NAILS @ 8" O.C.  
FOR FLUSH BOTTOM BEAMS PROVIDE 2X STACKED PLATES ATOP BEAM AS REQ'D. FASTEN PLATES IN SUCCESSION W/ (2) 3"x0.120" NAILS @ 8" O.C.

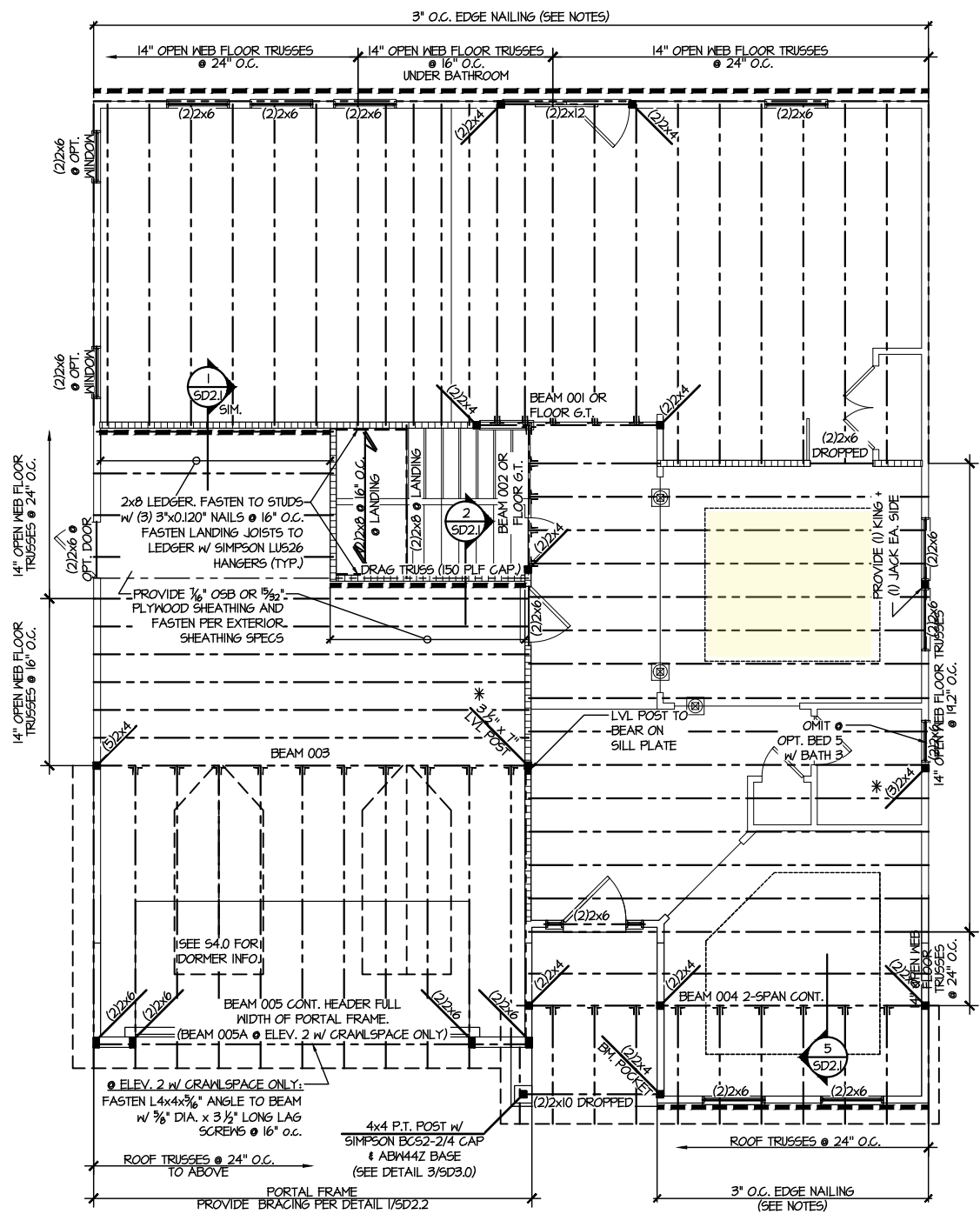

**1 2ND FLOOR FRAMING PLAN**  
SCALE: 1/8"=1'-0"  
ELEVATIONS #1 & #2

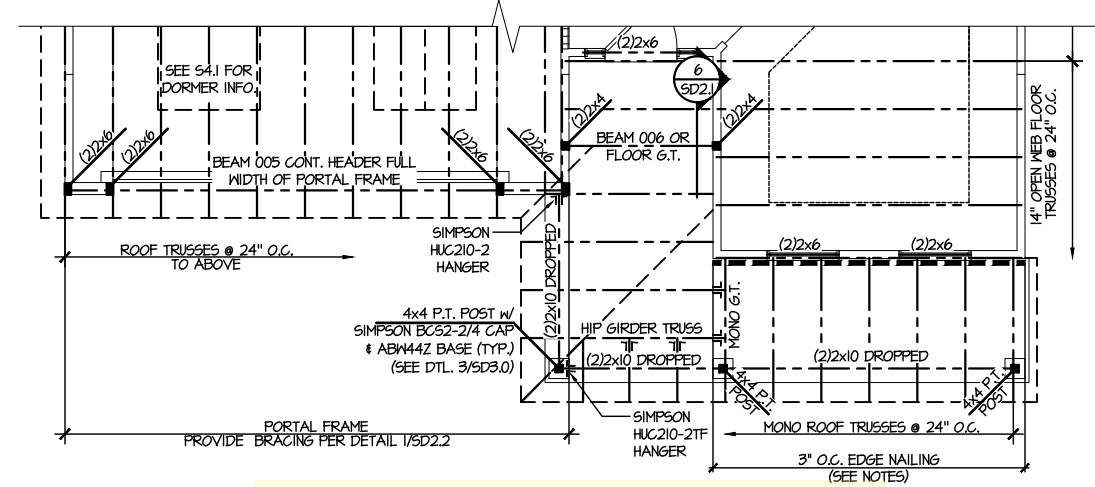

**2 PARTIAL 2ND FLOOR FRAMING PLAN**  
SCALE: 1/8"=1'-0"  
ELEVATION #3

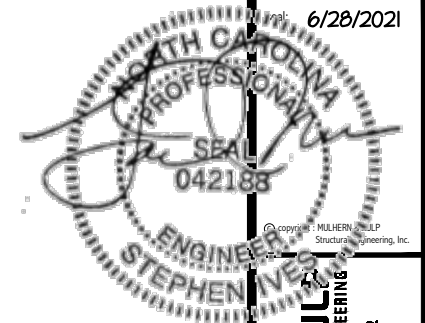

**MULHERN+KUL**  
RESIDENTIAL STRUCTURAL ENGINEERING  
300 Brookside Ave. Building 4 - Asheville, PA 18002  
P 215-448-8001 - mulhern@mkul.com  
N.C. #PG-5825

**LEGEND**

- ▬ INTERIOR BEARING WALL
- ▬ BEARING WALL ABOVE
- ▬ BEAM / HEADER
- ▬ INDICATES SHEAR WALL & EXTENT
- ▬ EXTENT OF OVERFRAMING
- JL METAL HANGER
- \* INDICATES POST ABOVE. PROVIDE SOLID BLOCKING UNDER POST OR JAMB ABOVE.
- ▶ INDICATES HOLD-DOWN OR STRAP. REFER TO SCHEDULE.

REFER TO 50.0 FOR TYPICAL STRUCTURAL NOTES & SCHEDULES

SD2.0 & SD2.1 REFERS TO SD2.0J & SD2.1J FOR I-JOIST FLOOR FRAMING OR SD2.0T & SD2.1T FOR TRUSS FLOOR FRAMING

SD2.1J/SD2.1T REFERS TO SD2.1JA/SD2.1TA FOR LVL/PSL/LSL BEAMS OR SD2.1JB/SD2.1TB FOR FLITCH BEAMS OR SD2.1JC/SD2.1TC FOR STEEL BEAMS

**ENGINEERED BEAM MATERIAL SCHEDULE**

BEAM NUMBER	LVL OPTION	PSL OPTION	LSL OPTION	FLITCH OPTION	STEEL OPTION
001	(2)3/4"x14" - F	3/2"x14" - F	(2)3/4"x14" - F	(2)2x12 + (1)1/2"x14" STEEL FLITCH PLATES - FB	M2x14 - F
002	(2)3/4"x14" - F	3/2"x14" - F	(2)3/4"x14" - F	(2)2x12 + (1)1/2"x14" STEEL FLITCH PLATES - FB	M2x14 - F
003	(3)3/4"x18" - FB or (2)3/4"x20" - FB	5/4"x18" - FB	N/A	(3)2x12 + (2)3/4"x14" STEEL FLITCH PLATES - FB	M2x26 - F
004	(2)3/4"x14" - F	3/2"x14" - F	(2)3/4"x14" - F	(2)2x12 + (2)3/4"x14" STEEL FLITCH PLATES - FB	M2x14 - F
005	(2)3/4"x11 1/2" - H cont.	3/2"x11 1/2" - H cont.	(2)3/4"x11 1/2" - H cont.	(3)2x12 + (2)3/4"x11 1/2" STEEL FLITCH PLATES - H cont.	N/A
005A	(3)3/4"x14" - H cont.	5/4"x14" - H cont.	N/A	(3)2x12 + (2)3/4"x14" STEEL FLITCH PLATES - H cont.	N/A
006	(1)3/4"x14" - F	3/2"x14" - F	(2)3/4"x14" - F	(2)2x12 + (1)1/2"x14" STEEL FLITCH PLATES - FB	M2x14 - F
007	(2)3/4"x11 1/2" - D	3/2"x11 1/2" - D	(2)3/4"x11 1/2" - D	(2)2x12 + (1)1/2"x14" STEEL FLITCH PLATES - D	M10x12 - D
008	(2)3/4"x16" - H cont.	3/2"x16" - H cont.	(3)3/4"x16" - H cont.	(3)2x12 + (2)3/4"x14" STEEL FLITCH PLATES - H cont.	N/A
004	(2)3/4"x9 1/4" - F	3/2"x9 1/4" - F	(2)3/4"x9 1/4" - F	(2)2x10 + (1)1/2"x9 1/4" STEEL FLITCH PLATES - F	M8x10 - F
010	(2)3/4"x14" - F	3/2"x14" - F	(2)3/4"x14" - F	(2)2x12 + (1)1/2"x14" STEEL FLITCH PLATES - FB	M2x14 - F
011	(2)3/4"x14" - F	3/2"x14" - F	(2)3/4"x14" - F	(2)2x12 + (1)1/2"x14" STEEL FLITCH PLATES - FB	M2x14 - F
012	(2)3/4"x11 1/2" - D	3/2"x11 1/2" - D	(2)3/4"x11 1/2" - D	(2)2x12 + (1)1/2"x14" STEEL FLITCH PLATES - D	M10x12 - D

**BEAM NOTATION:**

- "F" INDICATES FLUSH BEAM
- "FT" INDICATES FLUSH TOP BEAM
- "FB" INDICATES FLUSH BOTTOM BEAM
- "D" INDICATES DROPPED BEAM
- "H" INDICATES DROPPED OPENING HEADER

REFER TO DETAIL D/SD2.0 FOR TYPICAL FLITCH BEAM CONNECTIONS  
REFER TO DETAIL E/SD2.0 FOR TYPICAL STEEL BEAM CONNECTIONS  
FOR FLUSH TOP BEAMS PROVIDE 2X STACKED PLATES BENEATH BEAM AS REQ'D. FASTEN PLATES IN SUCCESSION W/ (2) 3"x0.120" NAILS @ 8" O.C.  
FOR FLUSH BOTTOM BEAMS PROVIDE 2X STACKED PLATES ATOP BEAM AS REQ'D. FASTEN PLATES IN SUCCESSION W/ (2) 3"x0.120" NAILS @ 8" O.C.

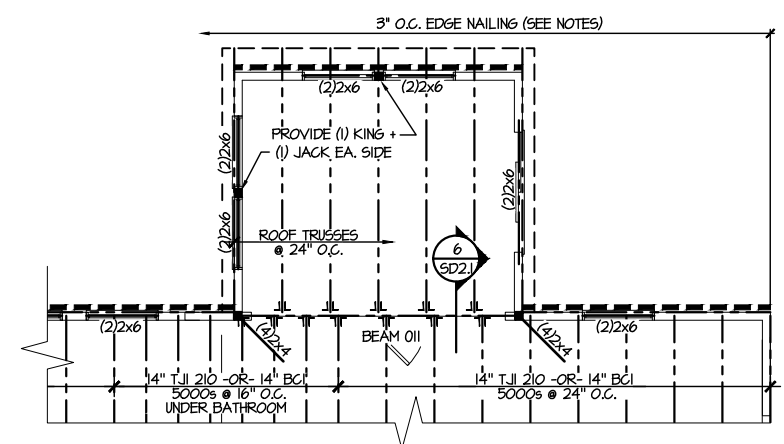

**5 PARTIAL SECOND FLOOR FRAMING PLAN**  
**OPTIONAL EXT. BREAKFAST**  
SCALE: 1/8"=1'-0" ELEV. #1 SHOWN - ALL ELEV. SIM.



OPTION FRAMING PLANS  
DRAYTON  
RALEIGH, NC

REFER TO S.O FOR TYPICAL STRUCTURAL NOTES & SCHEDULES

SD2.0 & SD2.I REFERS TO SD2.OJ & SD2.IJ FOR I-JOIST FLOOR FRAMING OR SD2.OT & SD2.IT FOR TRUSS FLOOR FRAMING

SD2.IJ/SD2.IT REFERS TO SD2.IJA/SD2.ITA FOR LVL/PSL/LSL BEAMS OR SD2.IJB/SD2.ITB FOR FLITCH BEAMS OR SD2.IJC/SD2.ITC FOR STEEL BEAMS

LEGEND

- [Symbol] INTERIOR BEARING WALL
- [Symbol] BEARING WALL ABOVE
- [Symbol] BEAM / HEADER
- [Symbol] INDICATES SHEAR WALL & EXTENT
- [Symbol] EXTENT OF OVERFRAMING
- JL METAL HANGER
- \* INDICATES POST ABOVE. PROVIDE SOLID BLOCKING UNDER POST OR JAMB ABOVE.
- ▶ INDICATES HOLD-DOWN OR STRAP. REFER TO SCHEDULE.

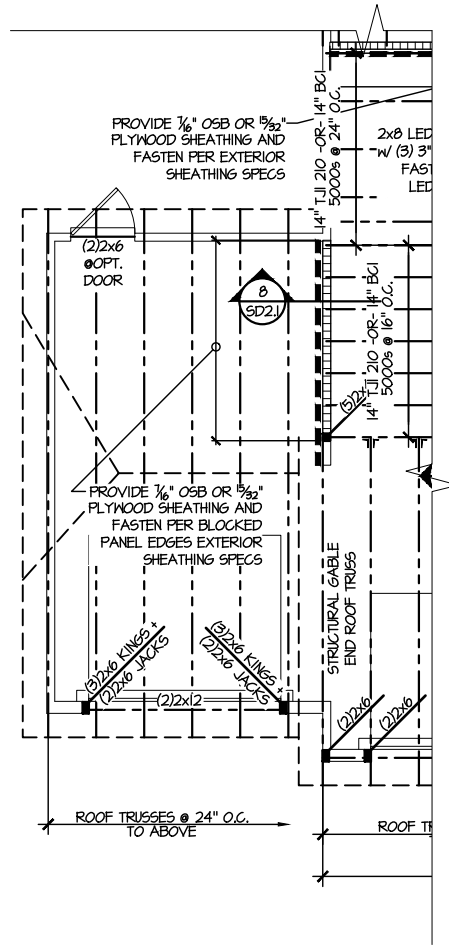

1 PARTIAL SECOND FLOOR FRAMING PLAN  
 OPTIONAL 3RD CAR GARAGE  
 SCALE: 1/8"=1'-0" ELEV. #1 SHOWN - ALL ELEVS. SIM.

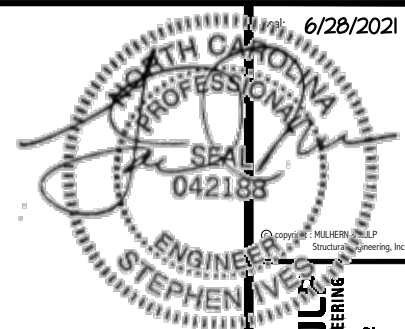

MULHERN+KUL  
 RESIDENTIAL STRUCTURAL ENGINEERING  
 500 Brookside Ave. Building 4 - Asheville, PA 18002  
 P 215-848-0071 • mulhern@mk.com  
 N.C. Lic. #E-3825



M&K project number:  
 126-21020  
 project mgr: JTR  
 drawn by: KL  
 issue date: 06-12-21

REVISIONS:  
 date: initial:



OPTION FRAMING PLANS  
 DRAYTON  
 RALEIGH, NC

sheet: LEFT HAND  
 S5.3T



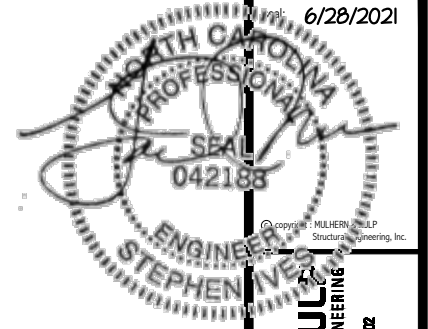

REFER TO SO.0 FOR  
TYPICAL STRUCTURAL NOTES  
& SCHEDULES

**LEGEND**

- [Symbol] INTERIOR BEARING WALL
- [Symbol] BEARING WALL ABOVE
- [Symbol] BEAM / HEADER
- [Symbol] INDICATES SHEAR WALL & EXTENT
- [Symbol] EXTENT OF OVERFRAMING
- [Symbol] METAL HANGER
- [Symbol] INDICATES POST ABOVE. PROVIDE SOLID BLOCKING UNDER POST OR JAMB ABOVE.
- [Symbol] INDICATES HOLD-DOWN OR STRAP. REFER TO SCHEDULE.

**MULHERN+KUL**  
RESIDENTIAL STRUCTURAL ENGINEERING

300 Riverside Ave., Building 4 - Durham, PA 19002  
P 215-664-5071 - mulhern+kul.com  
N.C. LIC. #53825

M&K project number: 126-21020

project mgr: JTR  
drawn by: KL  
issue date: 06-12-21

REVISIONS:

date:	initial:

**DRB GROUP**  
DRB GROUP  
DRB GROUP  
DRB GROUP  
DRB GROUP

ROOF FRAMING PLANS  
DRAYTON  
RALEIGH, NC

sheet: LEFT HAND  
**S4.0**

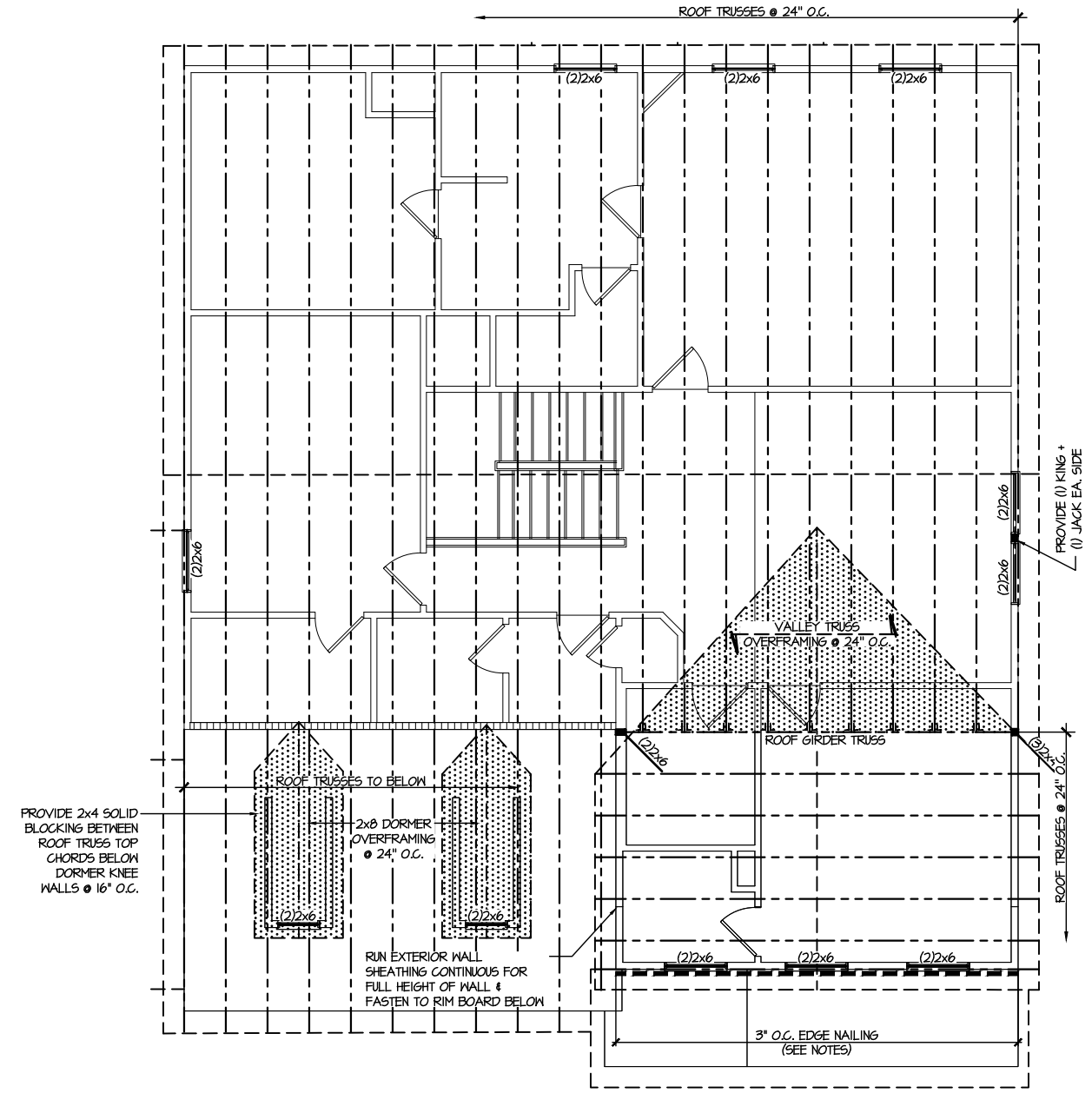

**2 PARTIAL ROOF FRAMING PLAN**  
SCALE: 1/8"=1'-0"  
ELEVATIONS #2

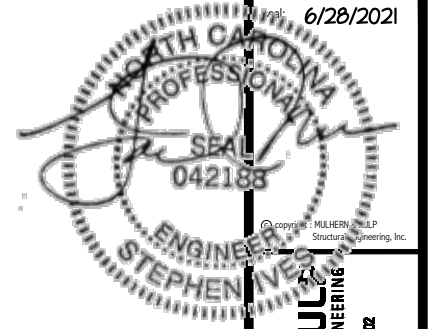

REFER TO 50.0 FOR  
TYPICAL STRUCTURAL NOTES  
& SCHEDULES

LEGEND	
	INTERIOR BEARING WALL
	BEARING WALL ABOVE
	BEAM / HEADER
	INDICATES SHEAR WALL & EXTENT
	EXTENT OF OVERFRAMING
	M METAL HANGER
	* INDICATES POST ABOVE. PROVIDE SOLID BLOCKING UNDER POST OR JAMB ABOVE.
	INDICATES HOLD-DOWN OR STRAP. REFER TO SCHEDULE.

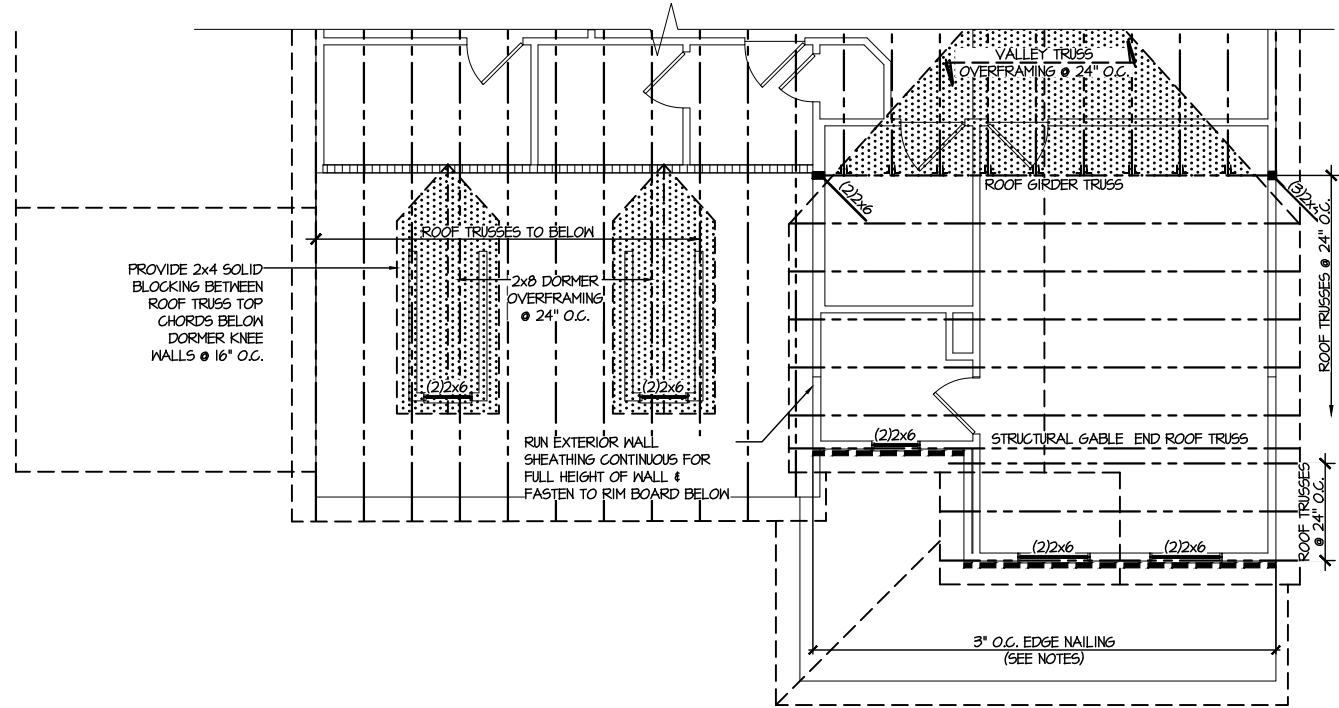

**1 PARTIAL ROOF FRAMING PLAN**  
 SCALE: 1/8"=1'-0"  
 ELEVATION #3  
 ADD'L INFO SEE ELEV. 2

**MULHERN+KUL**  
 RESIDENTIAL STRUCTURAL ENGINEERING  
 300 Riverside Ave., Building 4 - Annapolis, PA 18702  
 P 717-646-8071 - mulhern+kul.com  
 N.C. LIC. #S-3825



M&K project number:  
126-21020  
 project mgr: JTR  
 drawn by: KL  
 issue date: 06-12-21

REVISIONS:	
date:	initial:



ROOF FRAMING PLANS  
 DRAYTON  
 RALEIGH, NC

sheet: LEFT HAND  
**S4.1**

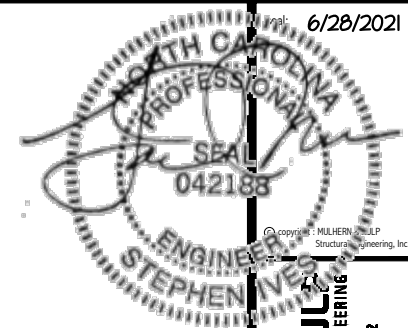

**MULHERN+KUL**  
RESIDENTIAL STRUCTURAL ENGINEERING  
300 Riverside Ave., Building 4 - Avondale, PA 19002  
P 215-646-8071 - mulhern+kul.com  
N.C.L.C. #53825



M&K project number:  
126-21020  
project mgr: JTR  
drawn by: KL  
issue date: 06-12-21

REVISIONS:  
date: initial:



FOUNDATION DETAILS  
DRAYTON  
RALEIGH, NC

sheet:  
**SD1.0**

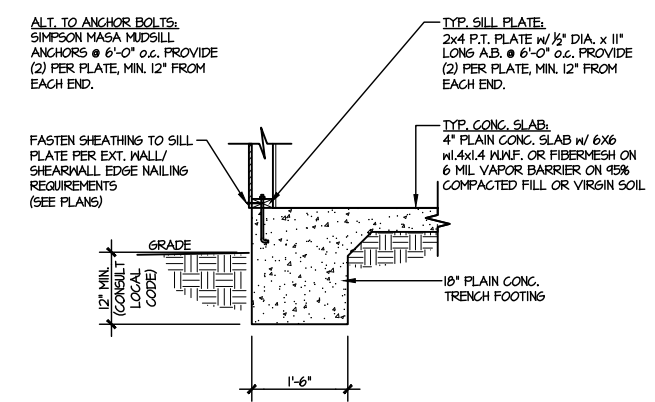

**1** TYPICAL SLAB ON GRADE PERIMETER FOOTING  
SCALE: 3/8"=1'-0"

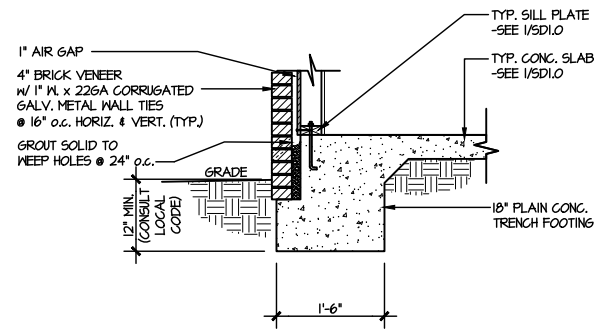

**2** TYPICAL SLAB ON GRADE PERIMETER FOOTING  
SCALE: 3/8"=1'-0" w/ BRICK VENEER

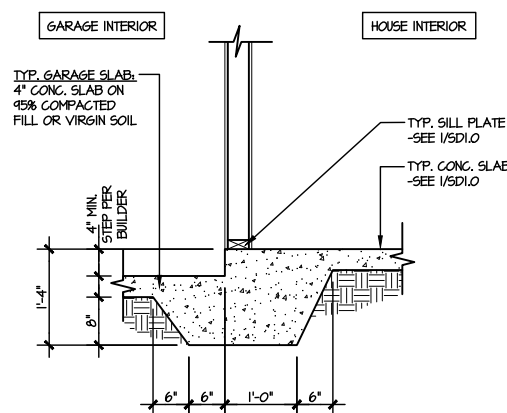

**3** TYPICAL MONOLITHIC INTERIOR GARAGE FOOTING  
SCALE: 3/8"=1'-0"

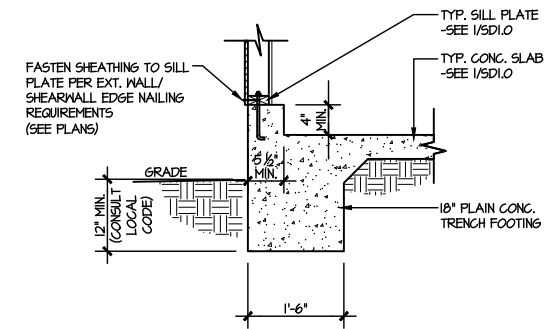

**4** TYPICAL SLAB ON GRADE GARAGE PERIMETER FOOTING  
SCALE: 3/8"=1'-0"

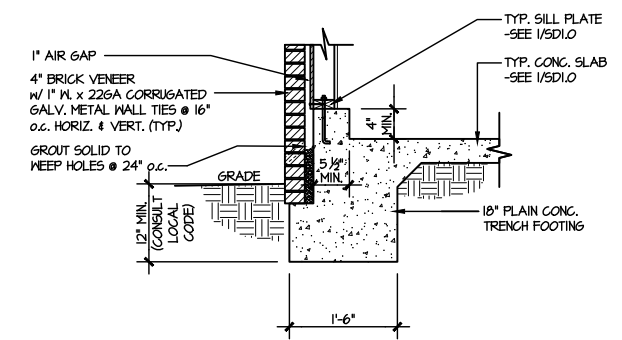

**5** TYPICAL SLAB ON GRADE GARAGE PERIMETER FOOTING  
SCALE: 3/8"=1'-0" w/ BRICK VENEER

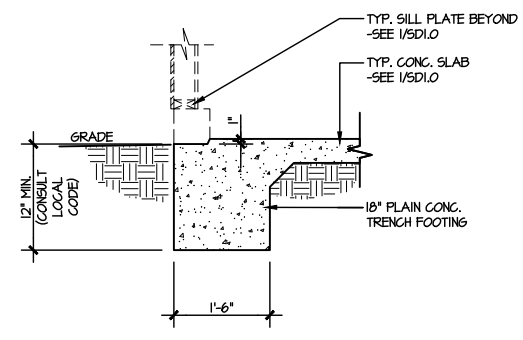

**6** TYPICAL SLAB ON GRADE GARAGE ENTRY @ PERIMETER FOOTING  
SCALE: 3/8"=1'-0"

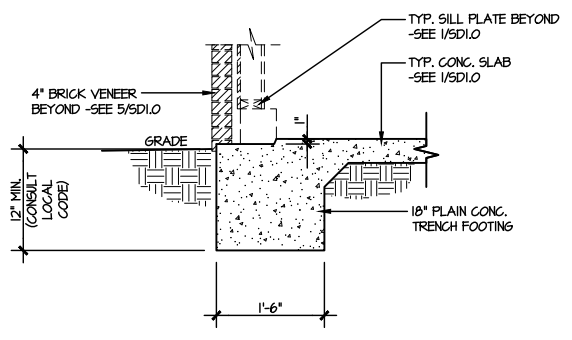

**7** TYPICAL SLAB ON GRADE GARAGE ENTRY @ PERIMETER FOOTING  
SCALE: 3/8"=1'-0" w/ BRICK VENEER

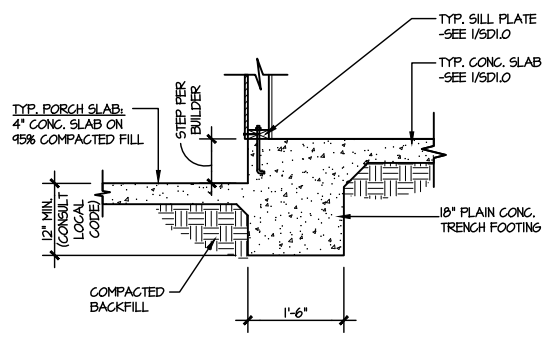

**8** TYPICAL SLAB ON GRADE PERIMETER FOOTING @ PORCH/PATIO  
SCALE: 3/8"=1'-0"

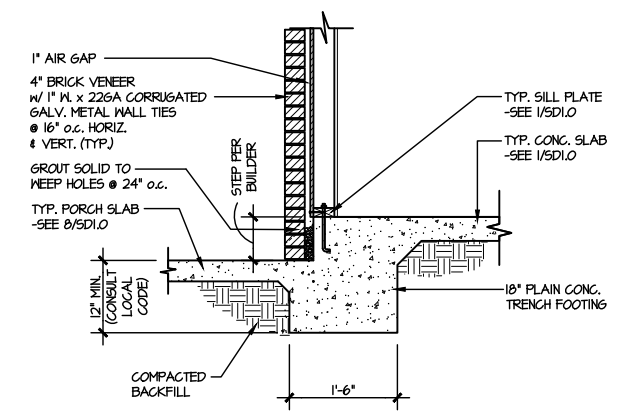

**9** TYPICAL SLAB ON GRADE PERIMETER FOOTING @ PORCH/PATIO  
SCALE: 3/8"=1'-0" w/ BRICK VENEER

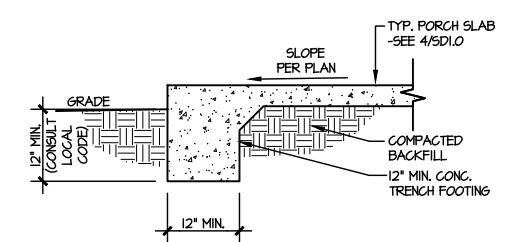

**10** TYPICAL FOOTING @ PORCH SLAB  
SCALE: 3/8"=1'-0"

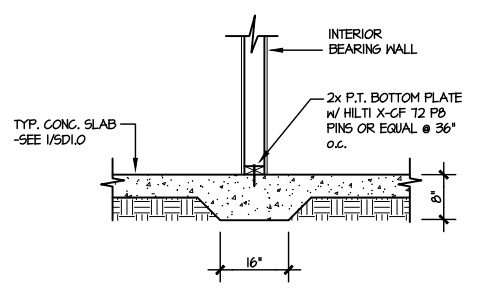

**11** TYPICAL THICKENED SLAB @ INTERIOR BEARING WALL  
SCALE: 3/8"=1'-0"

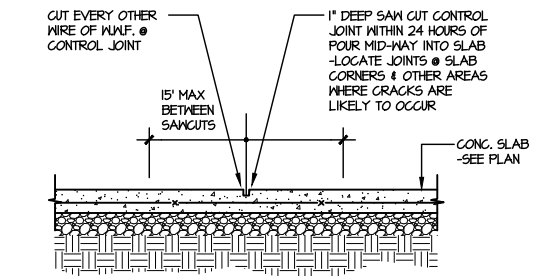

**A** TYPICAL CONTROL JOINT  
SCALE: 3/8"=1'-0" LOCATE @ 15'-0" o.c. MAX. OR CORNERS WHERE CRACKS LIKELY TO DEVELOP

FILE: RLH - Drayton - Structural DATE: 6/28/2021 2:42 PM

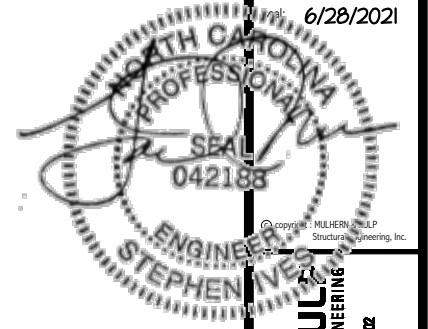

MULHERN+KULL  
RESIDENTIAL STRUCTURAL ENGINEERING  
300 Riverside Ave., Building 4 - Asheville, PA 18002  
P 715-645-5071 - mulhern+kull.com  
N.C.L.C. #5-3825



M&K project number:  
126-21020

project mgr: JTR  
drawn by: KL  
issue date: 06-12-21

REVISIONS:  
date: initial:



FRAMING DETAILS  
DRAYTON  
RALEIGH, NC

sheet:

SD2.0J

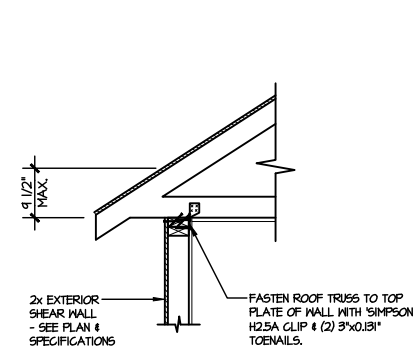

**A1** TYPICAL SHEAR TRANSFER DETAIL @ ROOF  
SCALE: 3/8"=1'-0"  
HEEL HEIGHT LESS THAN 9 1/2"  
NO BLOCKING REQ'D

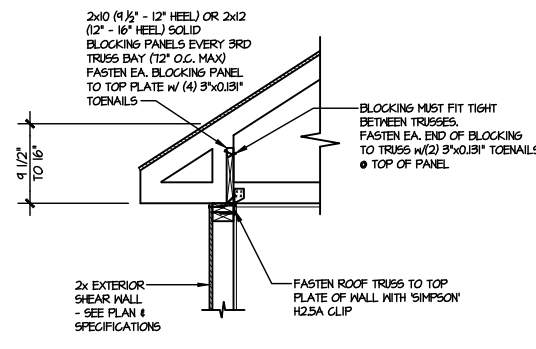

**A2** TYPICAL SHEAR TRANSFER DETAIL @ ROOF  
SCALE: 3/8"=1'-0"  
HEEL HEIGHT BETWEEN 9 1/2" - 16"  
BLOCKING REQ'D

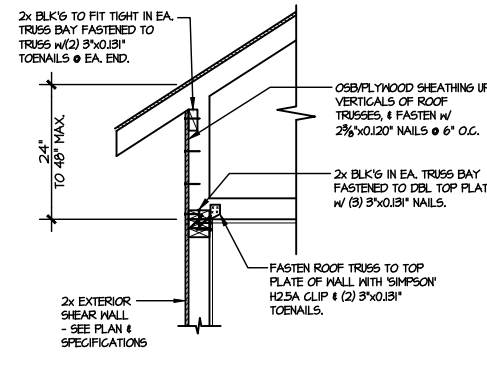

**A3** TYPICAL SHEAR TRANSFER DETAIL @ RAISED HEEL TRUSS  
SCALE: 3/8"=1'-0"  
HEEL HEIGHT UP TO 48" MAX.

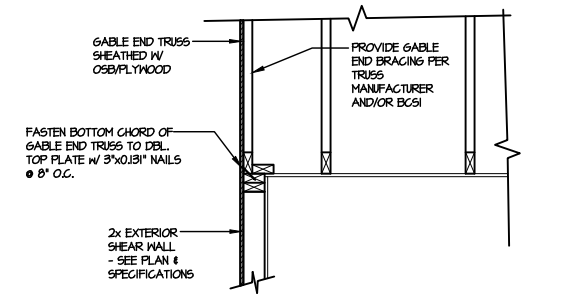

**B** TYPICAL GABLE END DETAIL  
SCALE: 3/8"=1'-0"

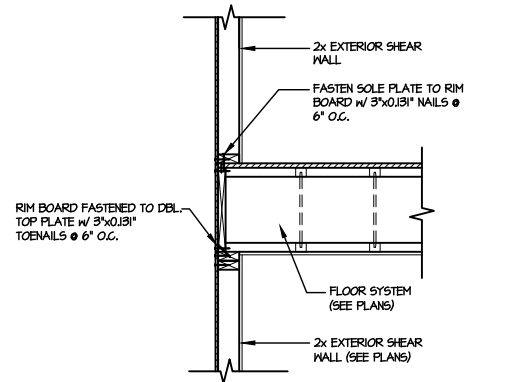

**C** TYPICAL SHEAR TRANSFER DETAIL BETWEEN FLOORS @ EXTERIOR WALL  
SCALE: 3/8"=1'-0"

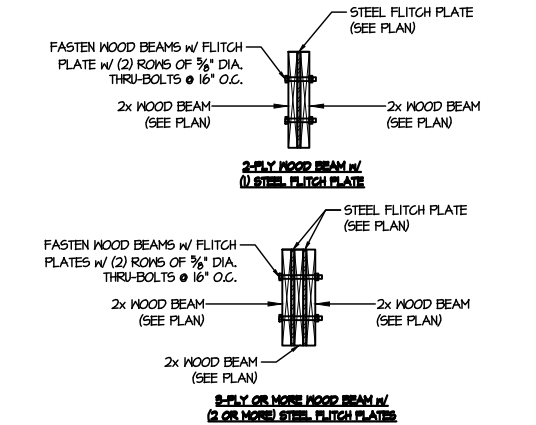

**D** TYPICAL FLITCH BEAM CONNECTION DETAIL  
SCALE: 3/4"=1'-0"

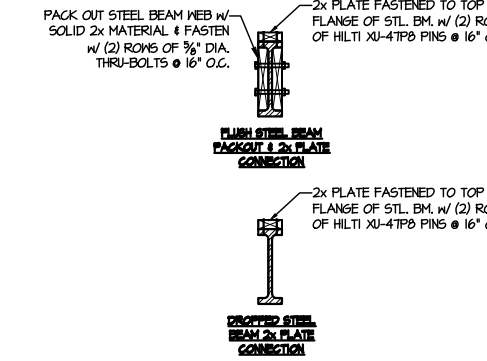

**E** TYPICAL STEEL BEAM CONNECTION DETAIL  
SCALE: 3/4"=1'-0"

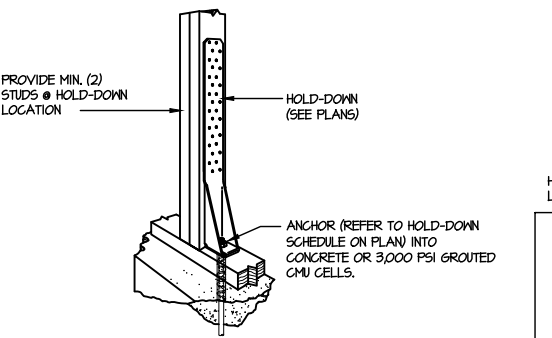

**F1** TYPICAL HOLD DOWN INSTALLATION  
SCALE: N.T.S.

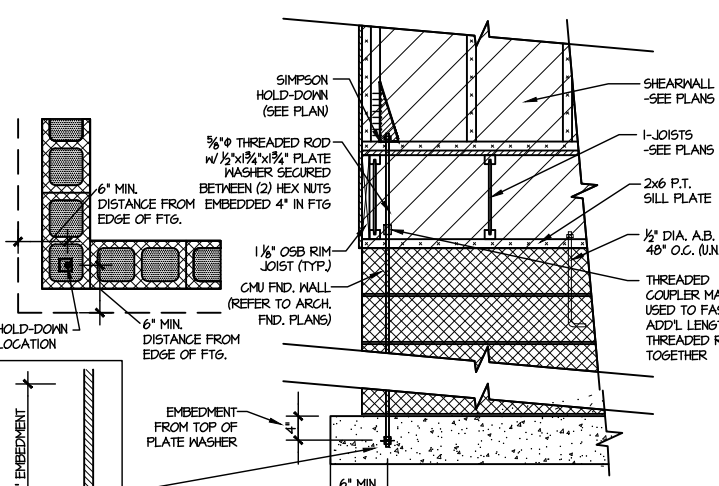

**F2** TYPICAL CMU FOUNDATION HOLD-DOWN INSTALLATION  
SCALE: N.T.S.  
(CORNER SHOWN - APPLICABLE TO ALL CONDITIONS)

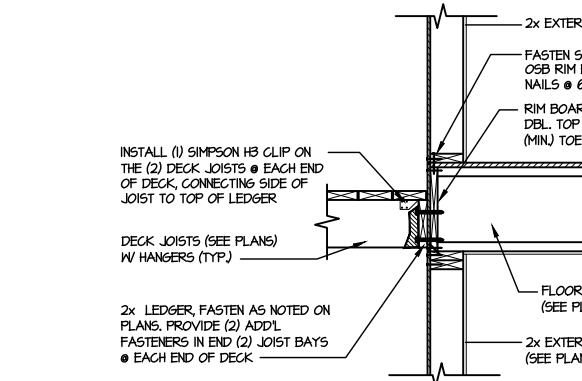

**G** DECK CONNECTION DETAIL  
SCALE: 3/4"=1'-0"



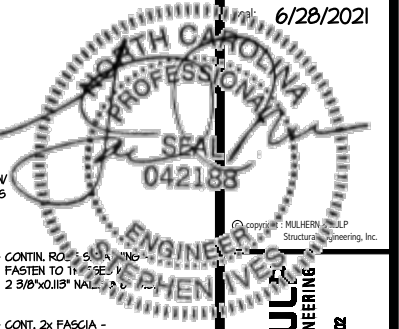

**MULHERN+KULICH**  
RESIDENTIAL STRUCTURAL ENGINEERING  
300 Rockside Ave, Building 4 - Aunim, PA 18002  
P 215-646-5071 - mulhern@mkp.com  
MLC# 04-3523



MX project number:  
**126-21020**  
project mgr: **JTR**  
draw by: **KL**  
issue date: **06-12-21**

REVISIONS:  
date: initial:

**DRB GROUP**  
DRB GROUP  
DRB GROUP  
DRB GROUP  
DRB GROUP

**FRAMING DETAILS**  
**DRAYTON**  
RALEIGH, NC

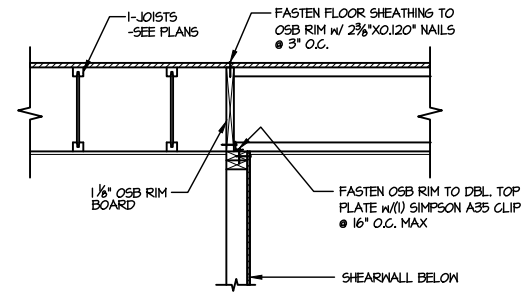

**1** SHEAR TRANSFER DETAIL @ INTERIOR SHEARWALL BELOW  
SCALE: 3/4"=1'-0" PARALLEL FRAMING

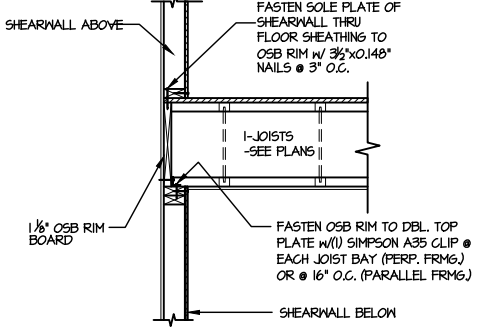

**2** SHEAR TRANSFER DETAIL @ INT. SHEARWALL ABOVE & BELOW  
SCALE: 3/4"=1'-0" EDGE OF FRAMING

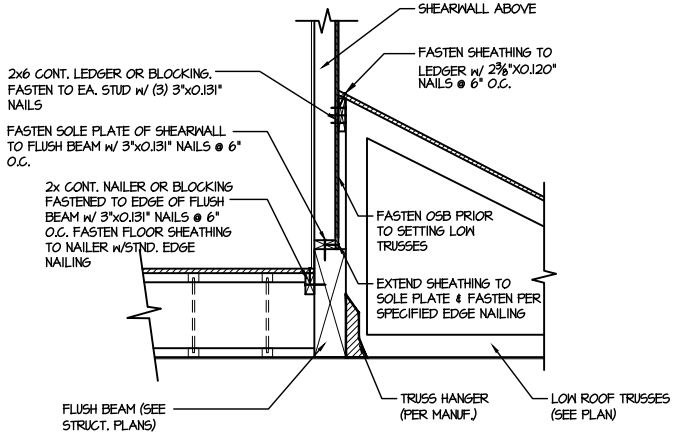

**3** SHEAR TRANSFER DETAIL @ EXTERIOR SHEARWALL ABOVE  
SCALE: 3/4"=1'-0"

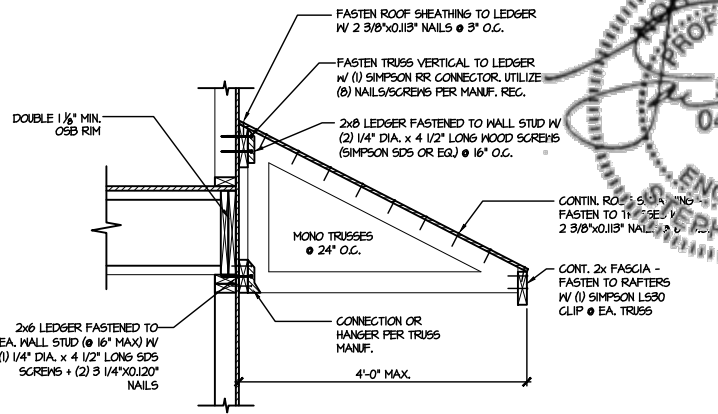

**4** DETAIL @ SHED ROOF  
SCALE: 3/8"=1'-0"

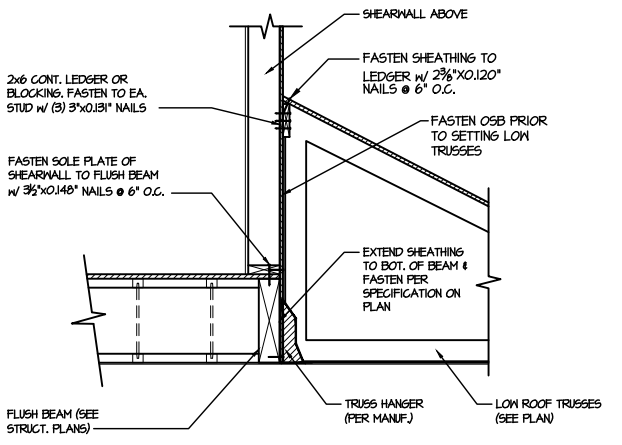

**5** SHEAR TRANSFER DETAIL @ EXTERIOR SHEARWALL ABOVE  
SCALE: 3/4"=1'-0"

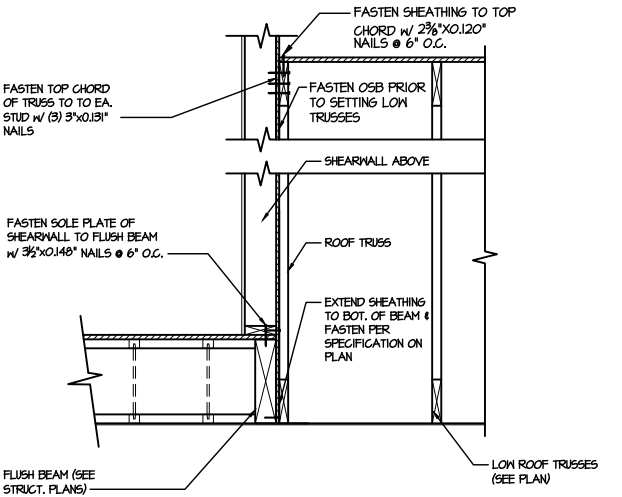

**6** SHEAR TRANSFER DETAIL @ EXTERIOR SHEARWALL ABOVE  
SCALE: 3/4"=1'-0"

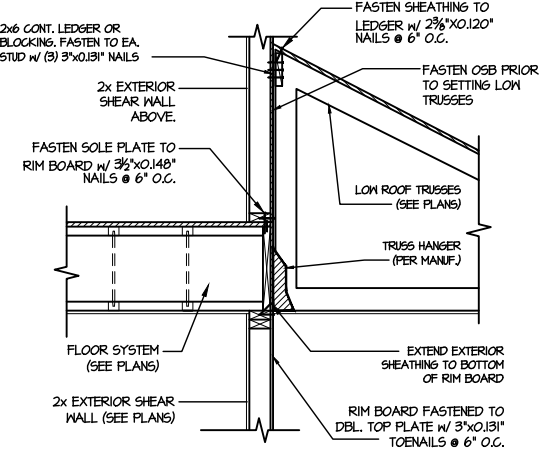

**7** TYPICAL SHEAR TRANSFER DETAIL BETWEEN FLOORS @ INTERIOR WALL  
SCALE: 3/4"=1'-0"

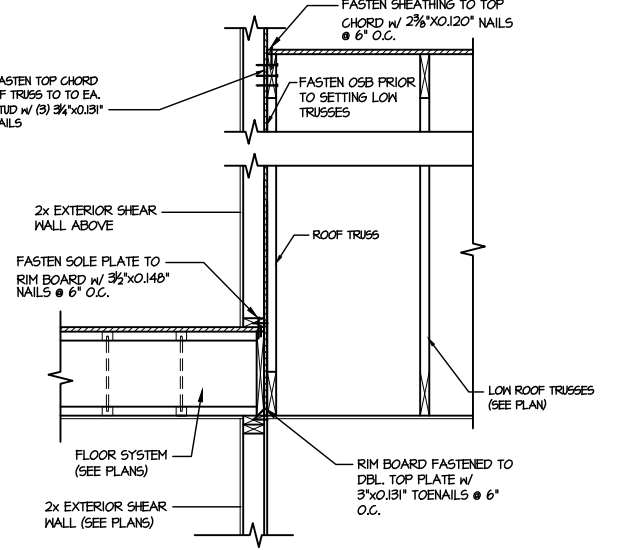

**8** TYPICAL SHEAR TRANSFER DETAIL BETWEEN FLOORS @ INTERIOR WALL  
SCALE: 3/4"=1'-0"

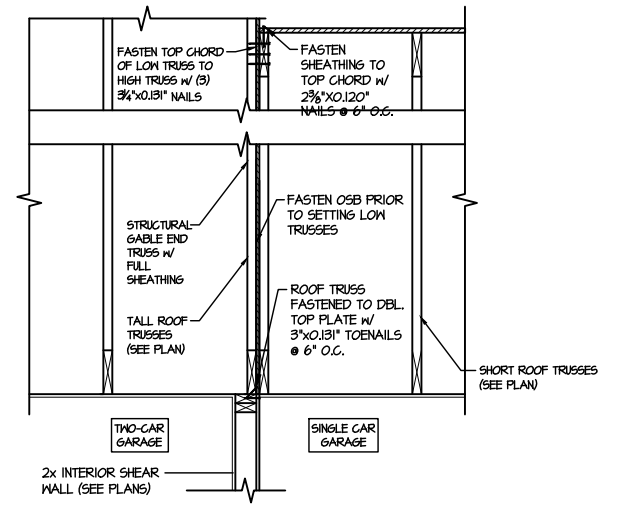

**9** TYPICAL SHEAR TRANSFER DETAIL BETWEEN GARAGE BAYS  
SCALE: 3/4"=1'-0"

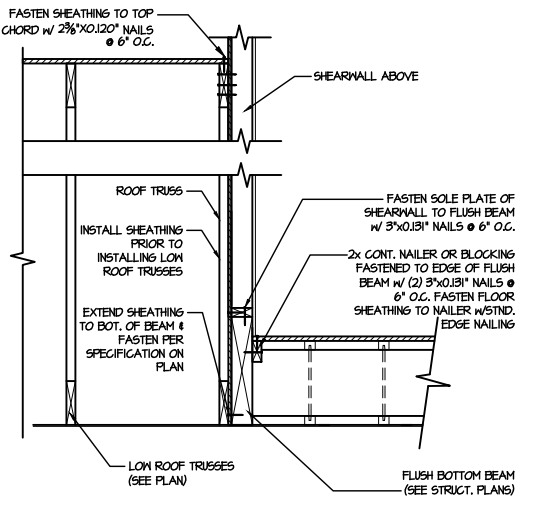

**10** SHEAR TRANSFER DETAIL @ EXTERIOR SHEARWALL ABOVE  
SCALE: 3/4"=1'-0"

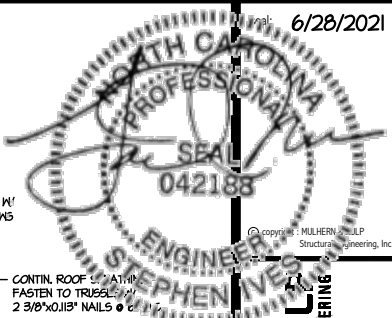

**MULHERN+KUL**  
RESIDENTIAL STRUCTURAL ENGINEERING  
300 Riverside Ave., Building 4 - Asheville, PA 18002  
P 715-646-5071 F 715-646-5072  
MLC#-R-5382

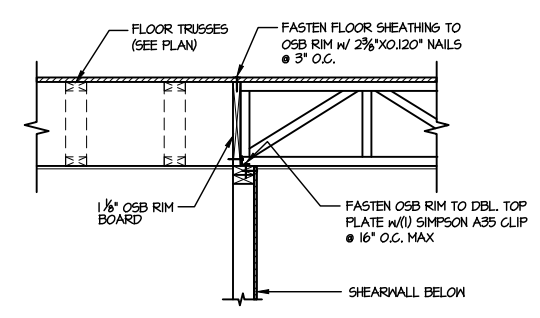

**1** SHEAR TRANSFER DETAIL @ INTERIOR SHEARWALL BELOW  
SCALE: 3/4"=1'-0"  
PARALLEL FRAMING

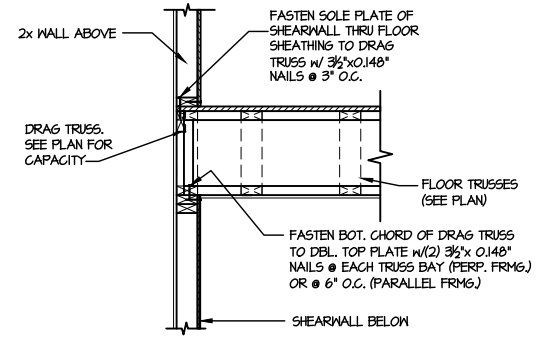

**2** SHEAR TRANSFER DETAIL @ INT. SHEARWALL ABOVE & BELOW  
SCALE: 3/4"=1'-0"  
EDGE OF FRAMING

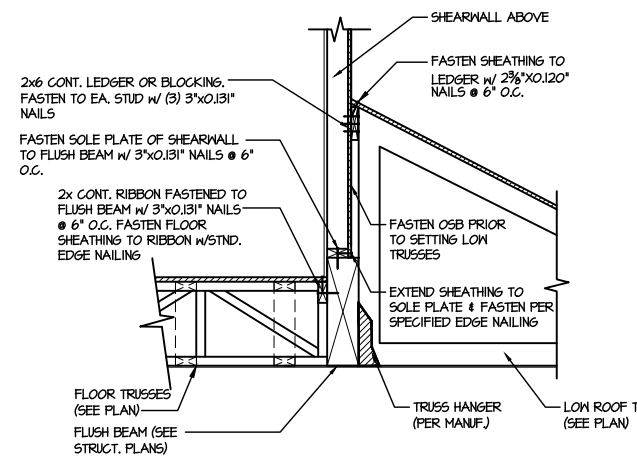

**3** SHEAR TRANSFER DETAIL @ EXTERIOR SHEARWALL ABOVE  
SCALE: 3/4"=1'-0"

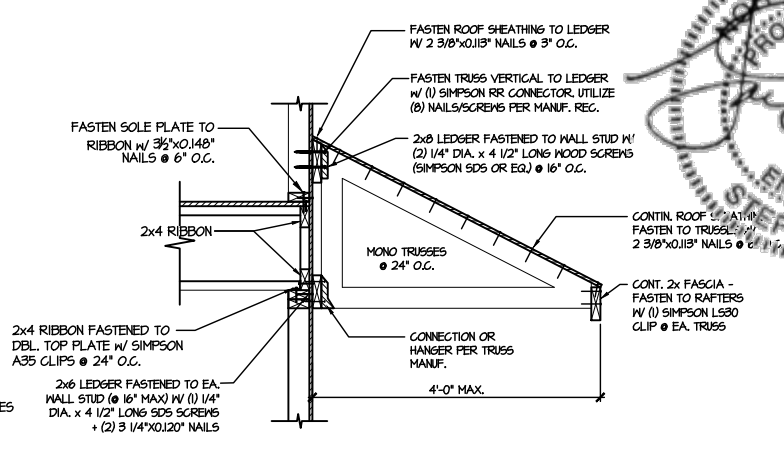

**4** DETAIL @ SHED ROOF  
SCALE: 3/8"=1'-0"

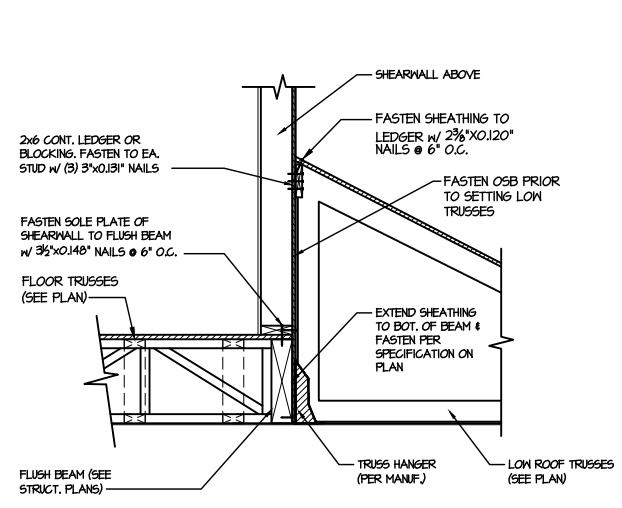

**5** SHEAR TRANSFER DETAIL @ EXTERIOR SHEARWALL ABOVE  
SCALE: 3/4"=1'-0"

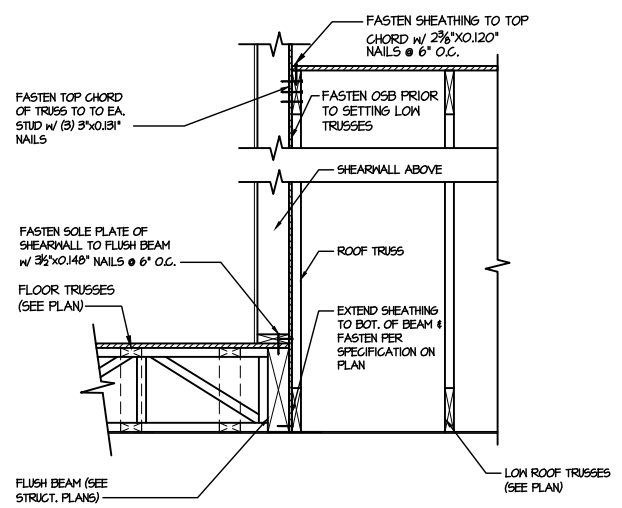

**6** SHEAR TRANSFER DETAIL @ EXTERIOR SHEARWALL ABOVE  
SCALE: 3/4"=1'-0"

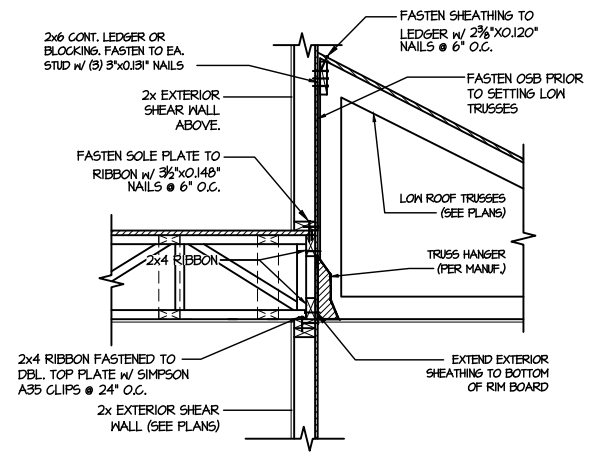

**7** TYPICAL SHEAR TRANSFER DETAIL BETWEEN FLOORS @ INTERIOR WALL  
SCALE: 3/4"=1'-0"

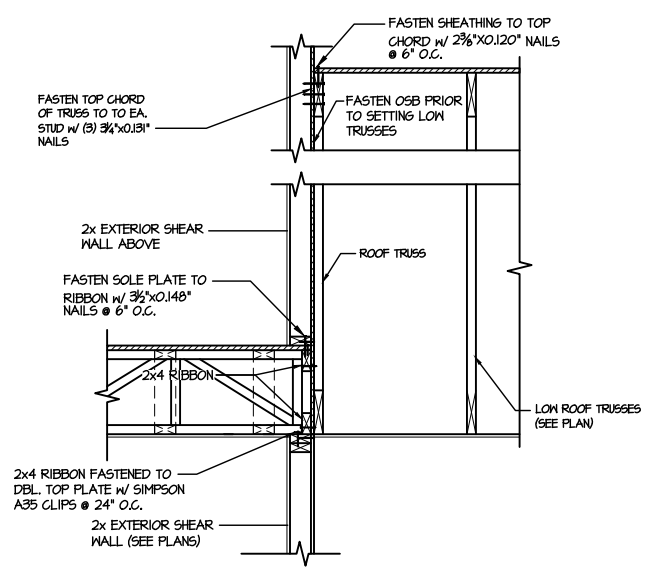

**8** TYPICAL SHEAR TRANSFER DETAIL BETWEEN FLOORS @ INTERIOR WALL  
SCALE: 3/4"=1'-0"

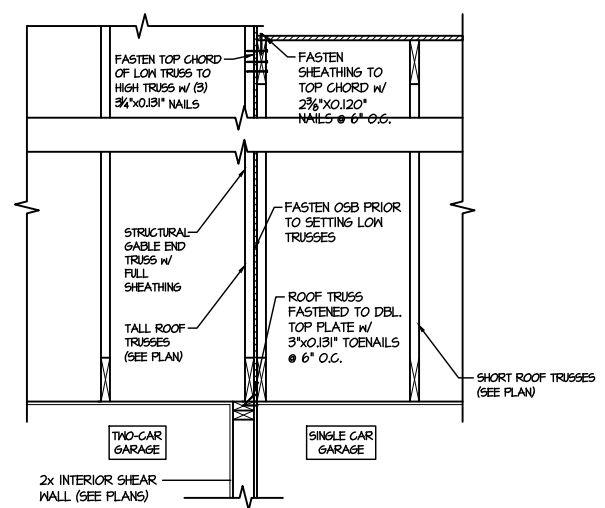

**9** TYPICAL SHEAR TRANSFER DETAIL BETWEEN GARAGE BAYS  
SCALE: 3/4"=1'-0"

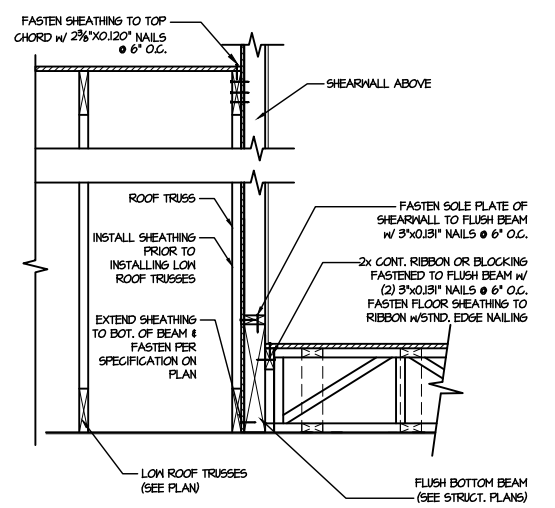

**13** SHEAR TRANSFER DETAIL @ EXTERIOR SHEARWALL ABOVE  
SCALE: 3/4"=1'-0"

M&K project number: 126-21020  
project mgr: JTR  
drawn by: KL  
issue date: 06-12-21

REVISIONS:  
date: initial:

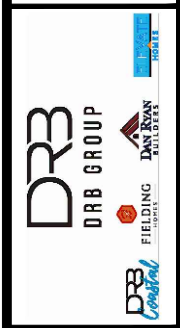

FRAMING DETAILS  
DRAYTON  
RALEIGH, NC

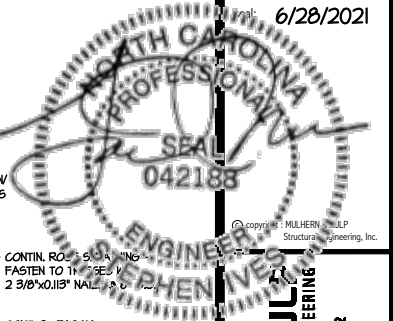

MULHERN+KUL...  
RESIDENTIAL STRUCTURAL ENGINEERING  
300 Brookside Ave., Building 4 - Avondale, PA 19002  
P 215-646-5071 - mulhern+kul.com  
LIC # 042188



M&K project number:  
126-21020  
project mgr: JTR  
drawn by: KL  
issue date: 06-12-21

REVISIONS:  
date: initial:



FRAMING DETAILS  
DRAYTON  
RALEIGH, NC

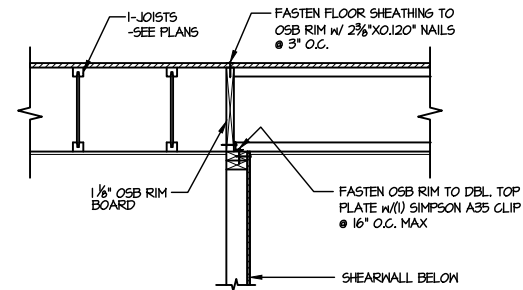

1 SHEAR TRANSFER DETAIL @ INTERIOR SHEARWALL BELOW  
SCALE: 3/4"=1'-0" PARALLEL FRAMING

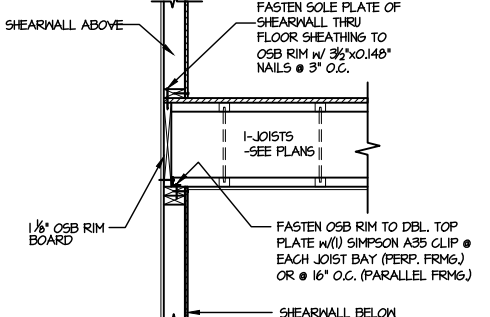

2 SHEAR TRANSFER DETAIL @ INT. SHEARWALL ABOVE & BELOW  
SCALE: 3/4"=1'-0" EDGE OF FRAMING

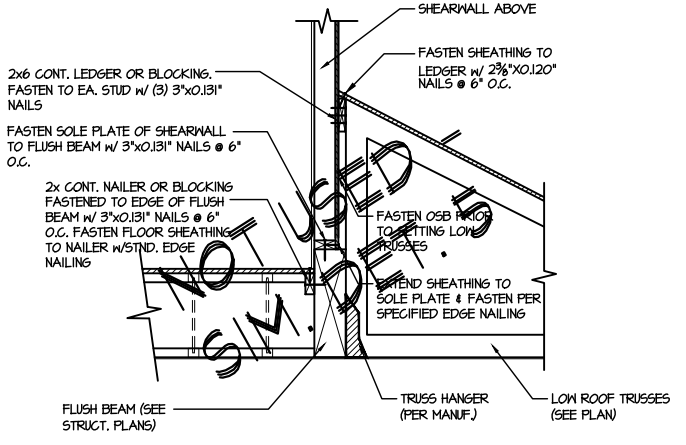

3 SHEAR TRANSFER DETAIL @ EXTERIOR SHEARWALL ABOVE  
SCALE: 3/4"=1'-0"

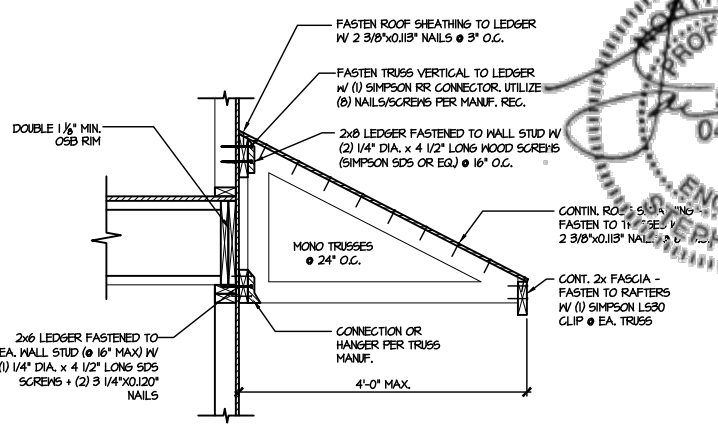

4 DETAIL @ SHED ROOF  
SCALE: 3/8"=1'-0"

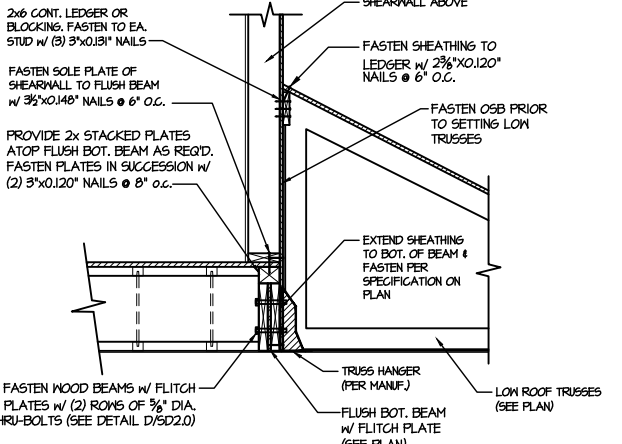

5 SHEAR TRANSFER DETAIL @ EXTERIOR SHEARWALL ABOVE  
SCALE: 3/4"=1'-0"

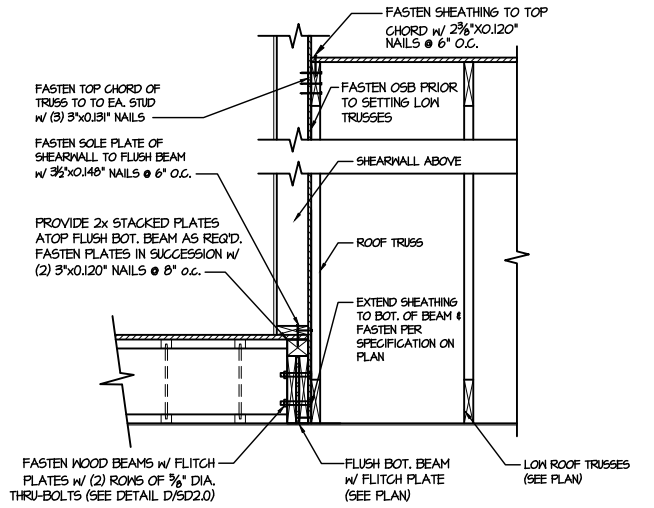

6 SHEAR TRANSFER DETAIL @ EXTERIOR SHEARWALL ABOVE  
SCALE: 3/4"=1'-0"

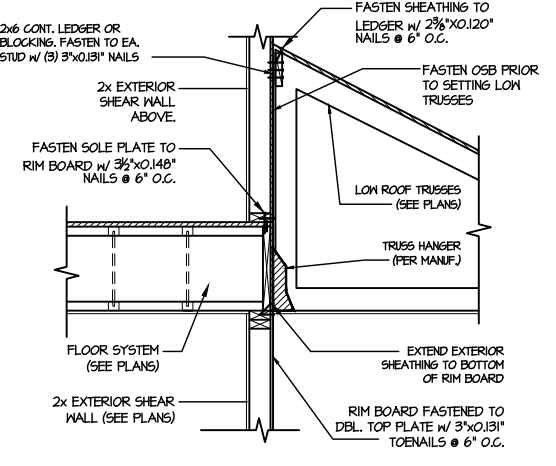

7 TYPICAL SHEAR TRANSFER DETAIL BETWEEN FLOORS @ INTERIOR WALL  
SCALE: 3/4"=1'-0"

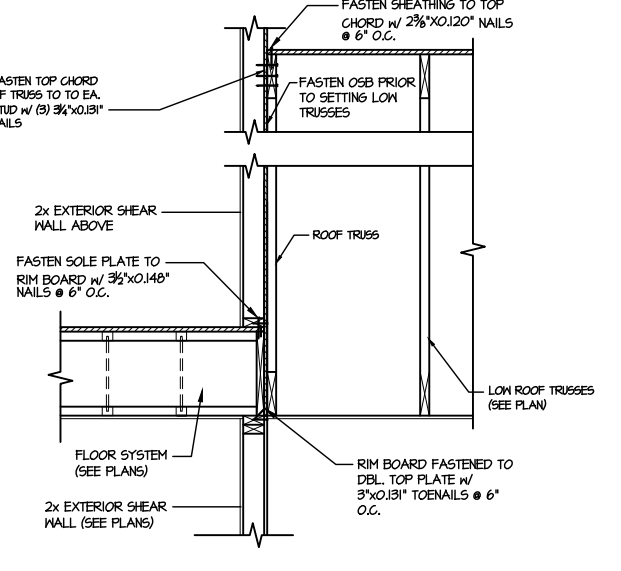

8 TYPICAL SHEAR TRANSFER DETAIL BETWEEN FLOORS @ INTERIOR WALL  
SCALE: 3/4"=1'-0"

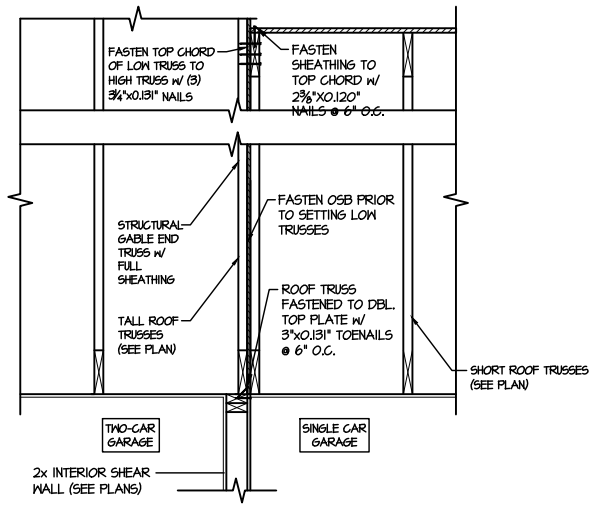

9 TYPICAL SHEAR TRANSFER DETAIL BETWEEN GARAGE BAYS  
SCALE: 3/4"=1'-0"

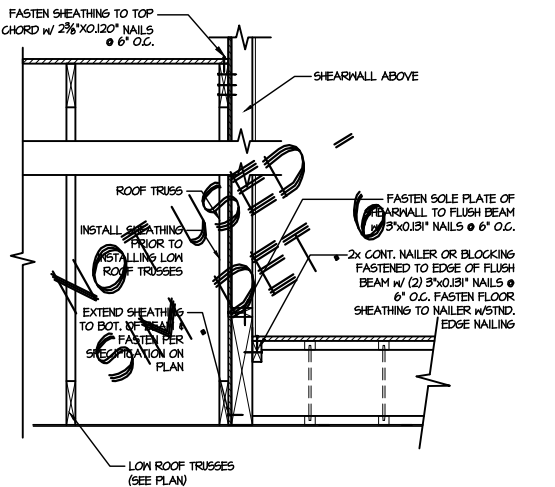

10 SHEAR TRANSFER DETAIL @ EXTERIOR SHEARWALL ABOVE  
SCALE: 3/4"=1'-0"

FILE: RLH - Drayton - Structural DATE: 6/28/2021 2:47 PM



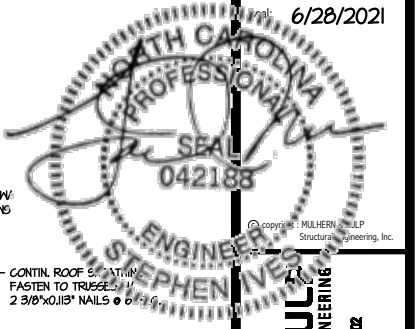

MULHERN+KUL  
RESIDENTIAL STRUCTURAL ENGINEERING  
300 Riverside Ave., Building 4 - Asheville, PA 18002  
P 715-646-5071 - mulhernmk@aol.com  
N.C.L.C. #5-3525

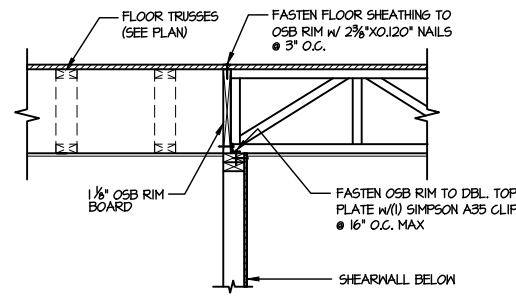

1 SHEAR TRANSFER DETAIL @ INTERIOR SHEARWALL BELOW  
SCALE: 3/4"=1'-0" PARALLEL FRAMING

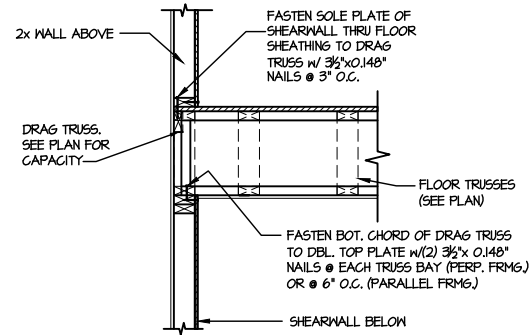

2 SHEAR TRANSFER DETAIL @ INT. SHEARWALL ABOVE & BELOW  
SCALE: 3/4"=1'-0" EDGE OF FRAMING

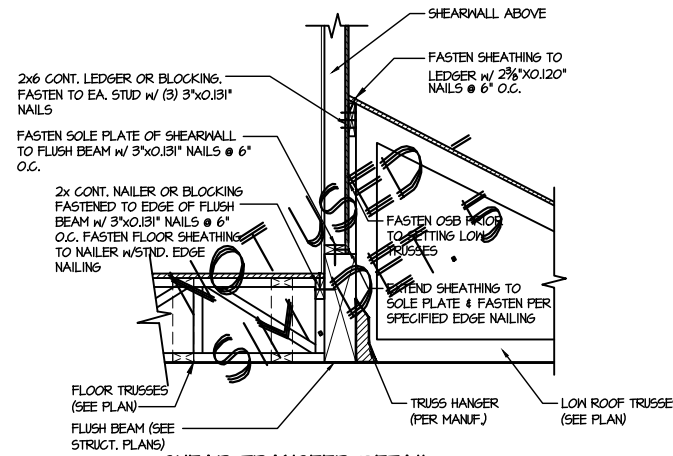

3 SHEAR TRANSFER DETAIL @ EXTERIOR SHEARWALL ABOVE  
SCALE: 3/4"=1'-0"

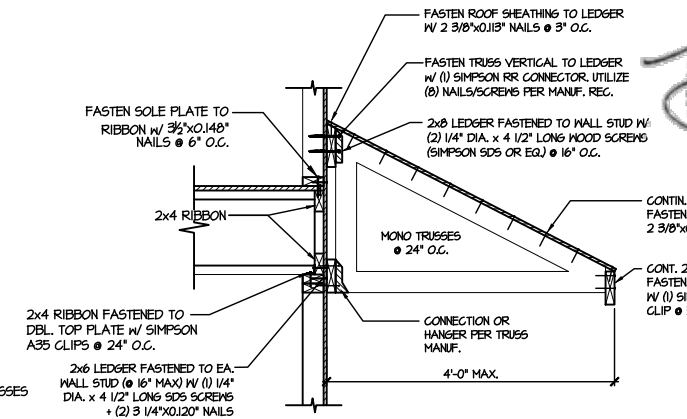

4 DETAIL @ SHED ROOF  
SCALE: 3/8"=1'-0"

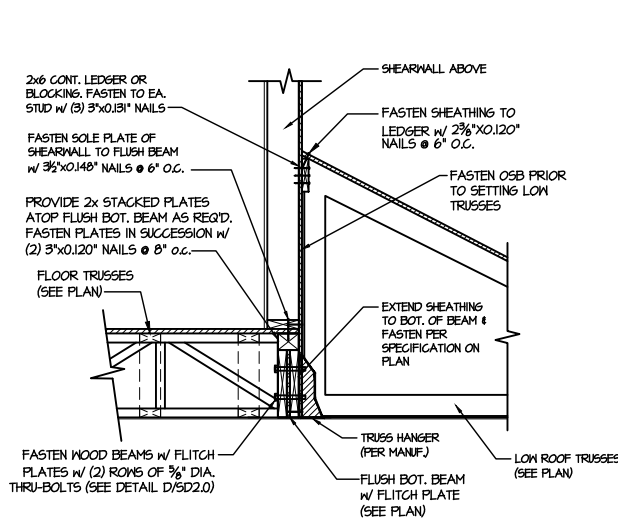

5 SHEAR TRANSFER DETAIL @ EXTERIOR SHEARWALL ABOVE  
SCALE: 3/4"=1'-0"

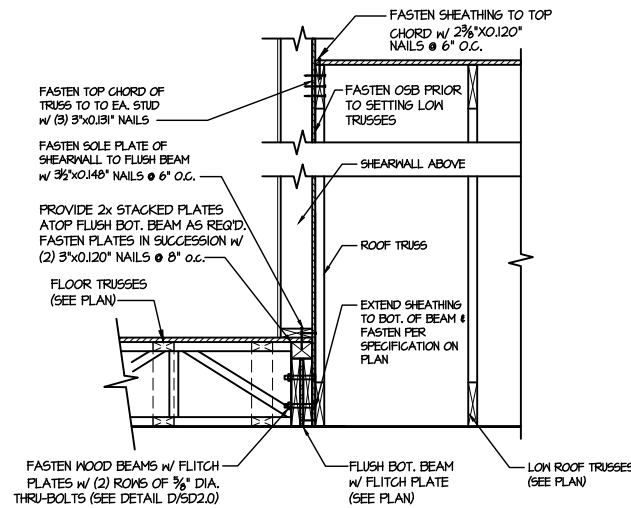

6 SHEAR TRANSFER DETAIL @ EXTERIOR SHEARWALL ABOVE  
SCALE: 3/4"=1'-0"

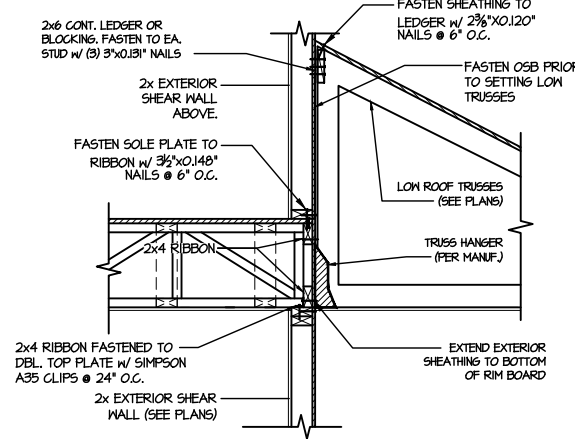

7 TYPICAL SHEAR TRANSFER DETAIL BETWEEN FLOORS @ INTERIOR WALL  
SCALE: 3/4"=1'-0"

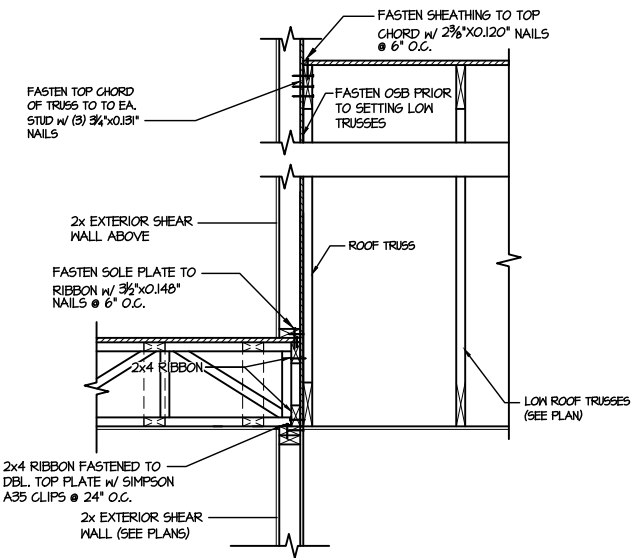

8 TYPICAL SHEAR TRANSFER DETAIL BETWEEN FLOORS @ INTERIOR WALL  
SCALE: 3/4"=1'-0"

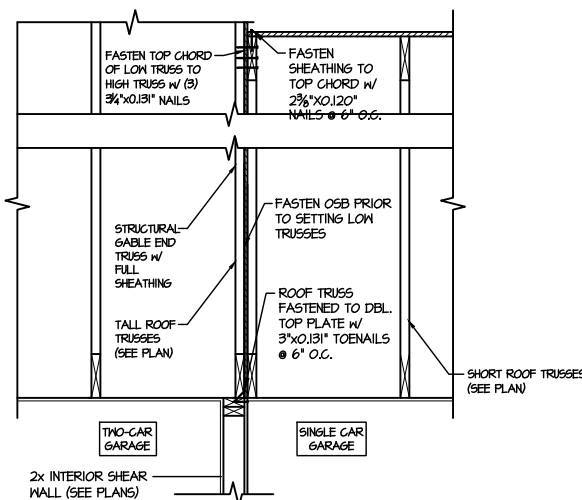

9 TYPICAL SHEAR TRANSFER DETAIL BETWEEN GARAGE BAYS  
SCALE: 3/4"=1'-0"

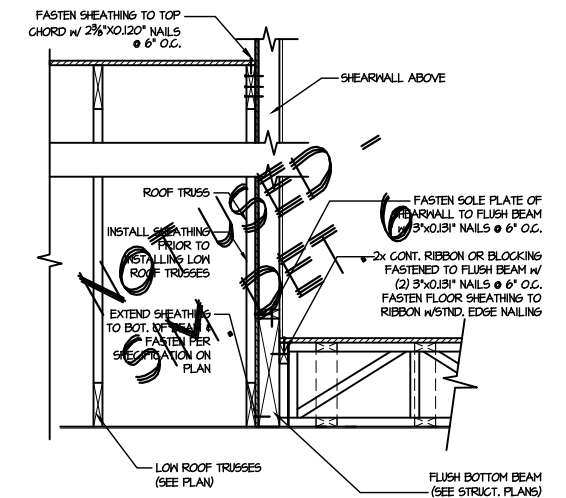

13 SHEAR TRANSFER DETAIL @ EXTERIOR SHEARWALL ABOVE  
SCALE: 3/4"=1'-0"

FILE: RLH - Drayton - Structurals DATE: 6/28/2021 2:48 PM



M&K project number: 126-21020  
project mgr: JTR  
draw by: KL  
issue date: 06-12-21

REVISIONS table with columns for date and initial.

DRB GROUP  
DRB GROUP  
DRB GROUP  
DRB GROUP

FRAMING DETAILS  
DRAYTON  
RALEIGH, NC



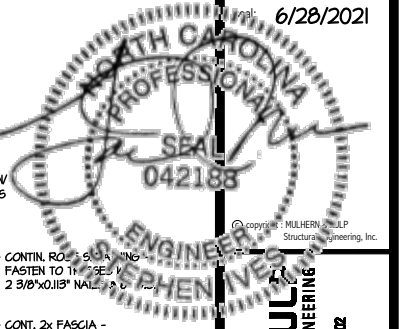

**MULHERN+KUL**  
RESIDENTIAL STRUCTURAL ENGINEERING  
300 Tradeville Ave., Building 4 - Asheville, PA 18002  
P 215-646-5071 - mulhern@mkp.com  
LIC. # S-3523

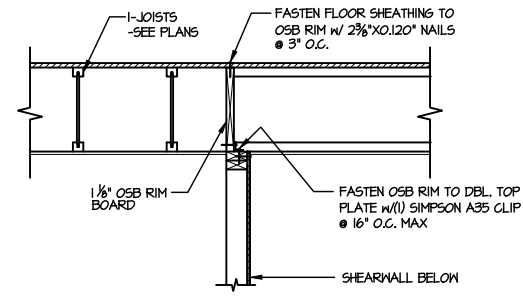

**1** SHEAR TRANSFER DETAIL @ INTERIOR SHEARWALL BELOW  
SCALE: 3/4"=1'-0" PARALLEL FRAMING

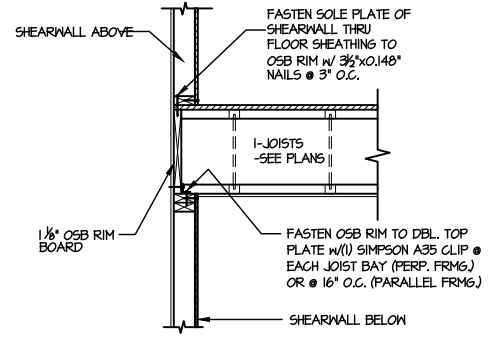

**2** SHEAR TRANSFER DETAIL @ INT. SHEARWALL ABOVE & BELOW  
SCALE: 3/4"=1'-0" EDGE OF FRAMING

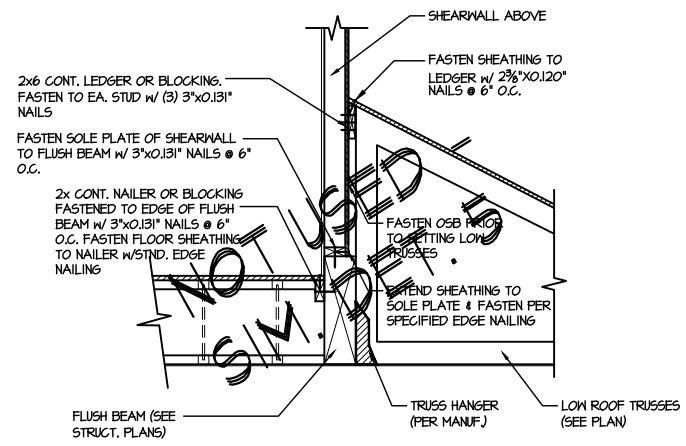

**3** SHEAR TRANSFER DETAIL @ EXTERIOR SHEARWALL ABOVE  
SCALE: 3/4"=1'-0"

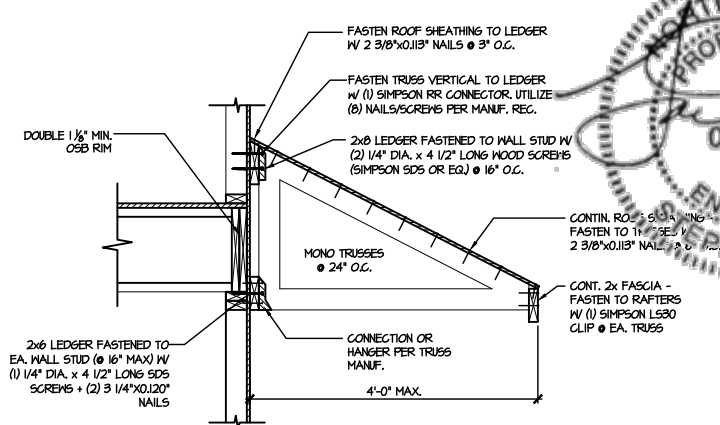

**4** DETAIL @ SHED ROOF  
SCALE: 3/8"=1'-0"

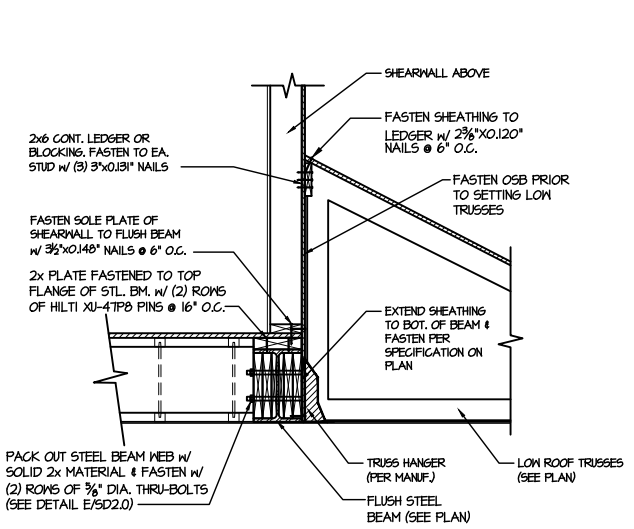

**5** SHEAR TRANSFER DETAIL @ EXTERIOR SHEARWALL ABOVE  
SCALE: 3/4"=1'-0"

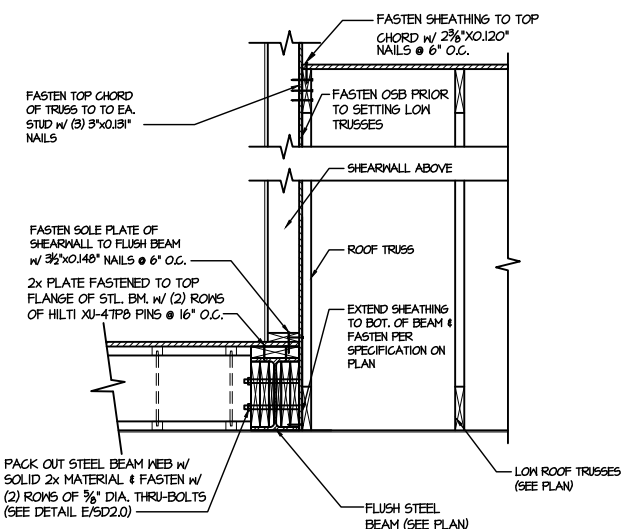

**6** SHEAR TRANSFER DETAIL @ EXTERIOR SHEARWALL ABOVE  
SCALE: 3/4"=1'-0"

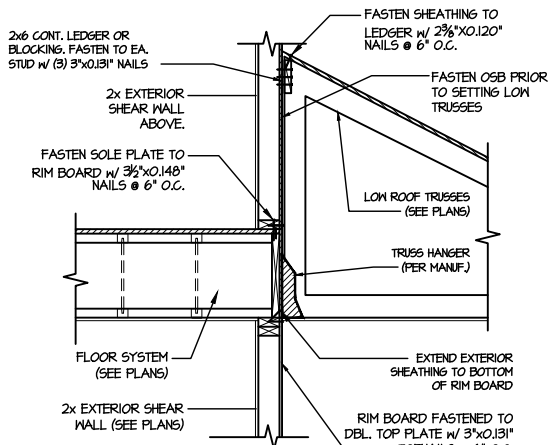

**7** TYPICAL SHEAR TRANSFER DETAIL BETWEEN FLOORS @ INTERIOR WALL  
SCALE: 3/4"=1'-0"

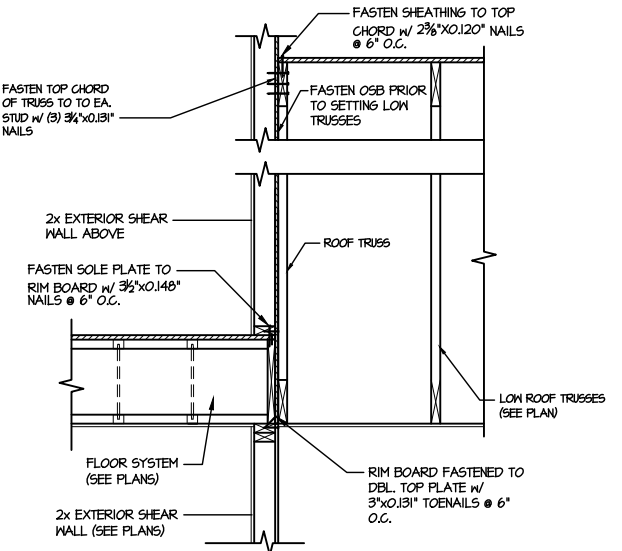

**8** TYPICAL SHEAR TRANSFER DETAIL BETWEEN FLOORS @ INTERIOR WALL  
SCALE: 3/4"=1'-0"

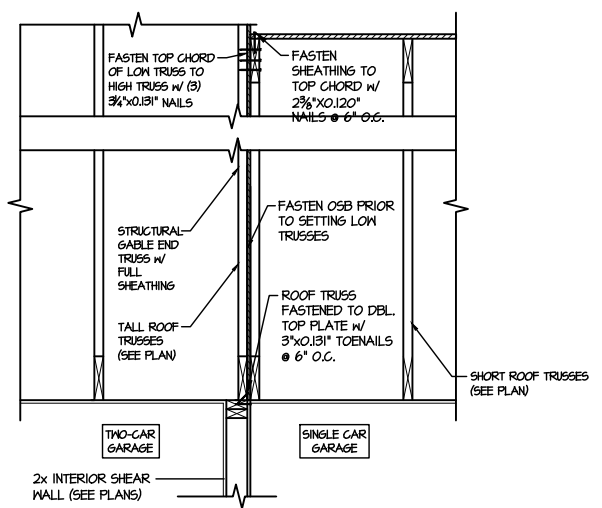

**9** TYPICAL SHEAR TRANSFER DETAIL BETWEEN GARAGE BAYS  
SCALE: 3/4"=1'-0"

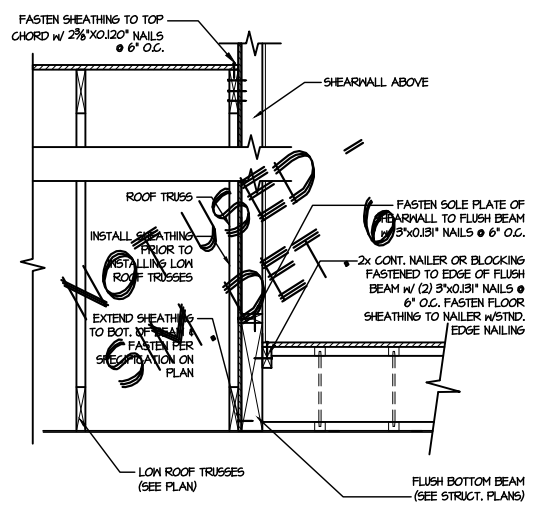

**10** SHEAR TRANSFER DETAIL @ EXTERIOR SHEARWALL ABOVE  
SCALE: 3/4"=1'-0"

FILE: RLH - Drayton - Structural DATE: 6/28/2021 2:48 PM



M&K project number: 126-21020  
project mgr: JTR  
drawn by: KL  
issue date: 06-12-21

REVISIONS:

date:	initial:

DRB GROUP  
DRB GROUP  
DRB GROUP  
DRB GROUP  
DRB GROUP

FRAMING DETAILS  
DRAYTON  
RALEIGH, NC

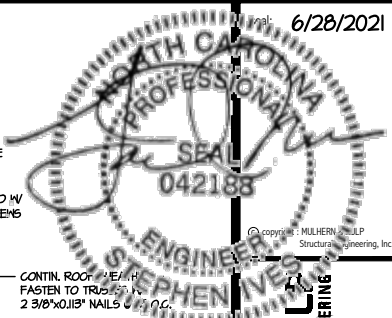

MULHERN+KUL... RESIDENTIAL STRUCTURAL ENGINEERING... 300 Riverside Ave., Building 4 - Asheville, PA 18002... P 715-646-8071 - mulhernmkp.com



M&K project number: 126-21020  
project mgr: JTR  
drawn by: KL  
issue date: 06-12-21

REVISIONS:  
date: initial:

DRB GROUP  
DRB GROUP  
DRB GROUP  
DRB GROUP  
DRB GROUP

FRAMING DETAILS  
DRAYTON  
RALEIGH, NC

sheet:

SD2.1CT

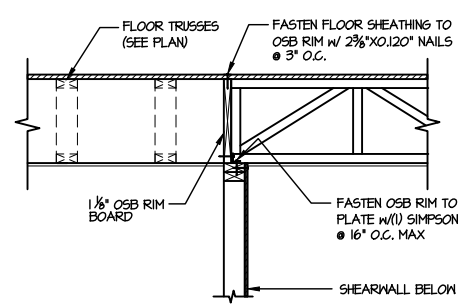

1 SHEAR TRANSFER DETAIL @ INTERIOR SHEARWALL BELOW  
SCALE: 3/4"=1'-0" PARALLEL FRAMING

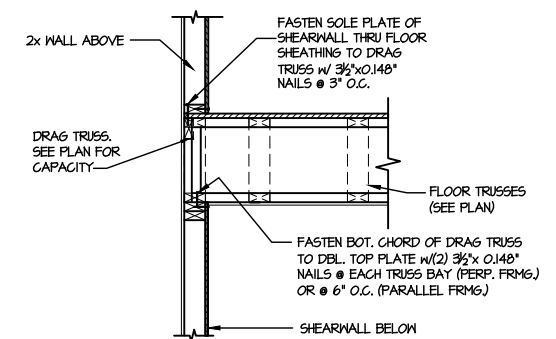

2 SHEAR TRANSFER DETAIL @ INT. SHEARWALL ABOVE & BELOW  
SCALE: 3/4"=1'-0" EDGE OF FRAMING

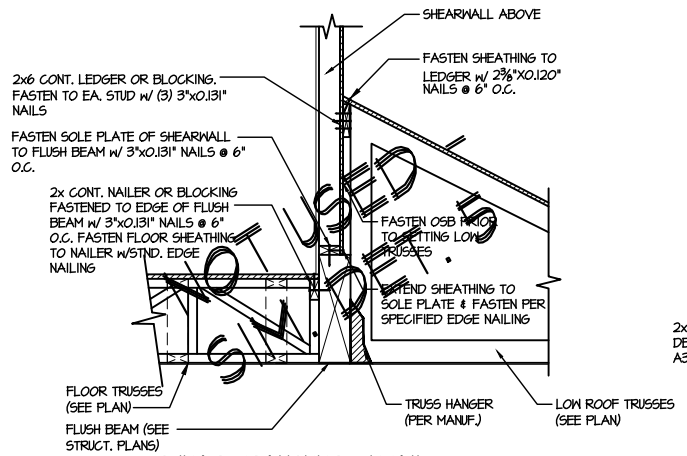

3 SHEAR TRANSFER DETAIL @ EXTERIOR SHEARWALL ABOVE  
SCALE: 3/4"=1'-0"

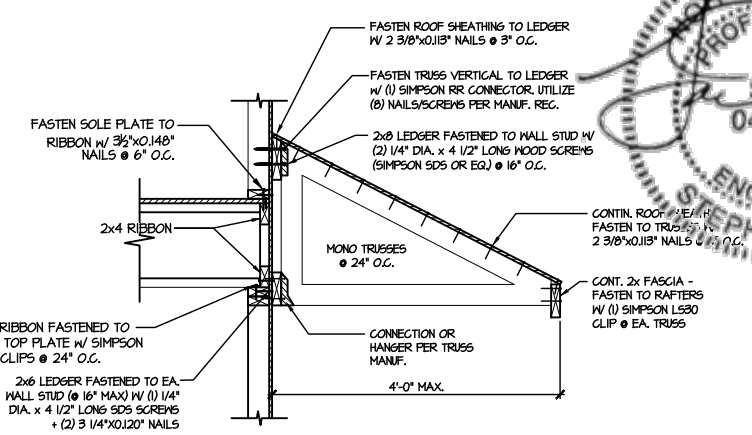

4 DETAIL @ SHED ROOF  
SCALE: 3/8"=1'-0"

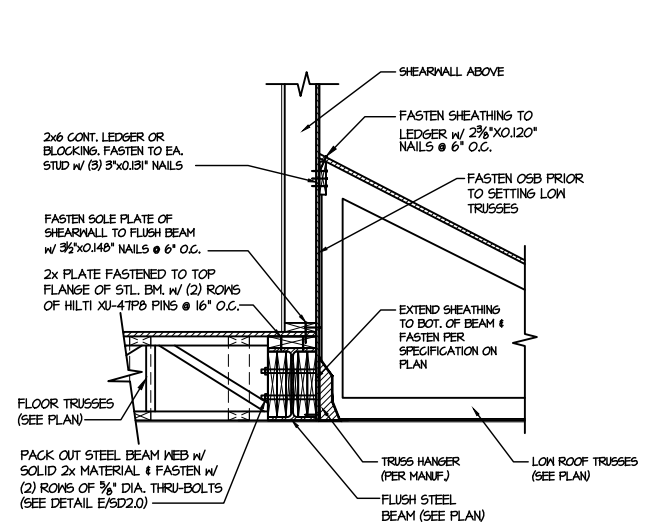

5 SHEAR TRANSFER DETAIL @ EXTERIOR SHEARWALL ABOVE  
SCALE: 3/4"=1'-0"

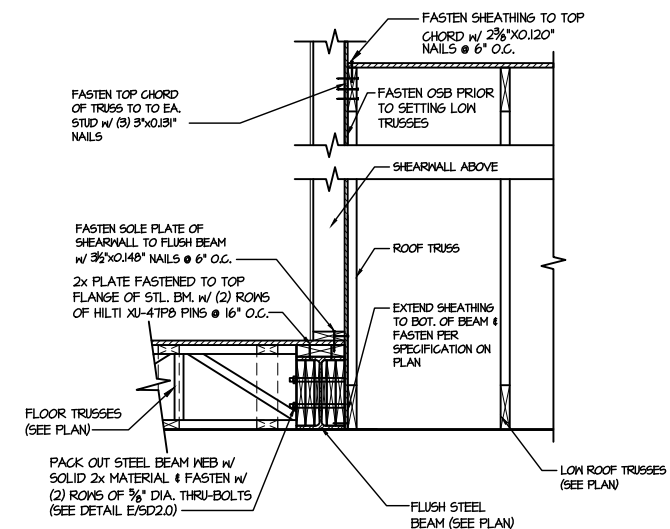

6 SHEAR TRANSFER DETAIL @ EXTERIOR SHEARWALL ABOVE  
SCALE: 3/4"=1'-0"

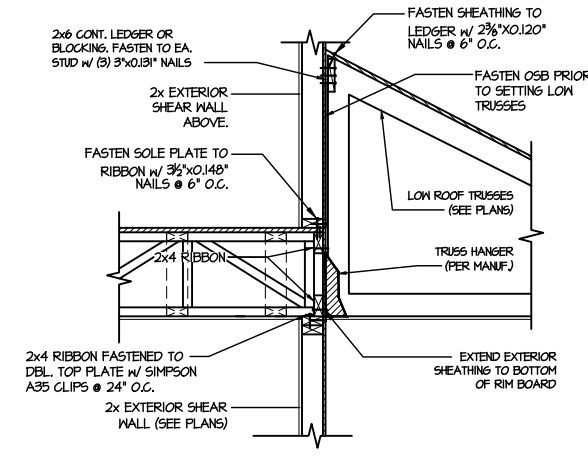

7 TYPICAL SHEAR TRANSFER DETAIL BETWEEN FLOORS @ INTERIOR WALL  
SCALE: 3/4"=1'-0"

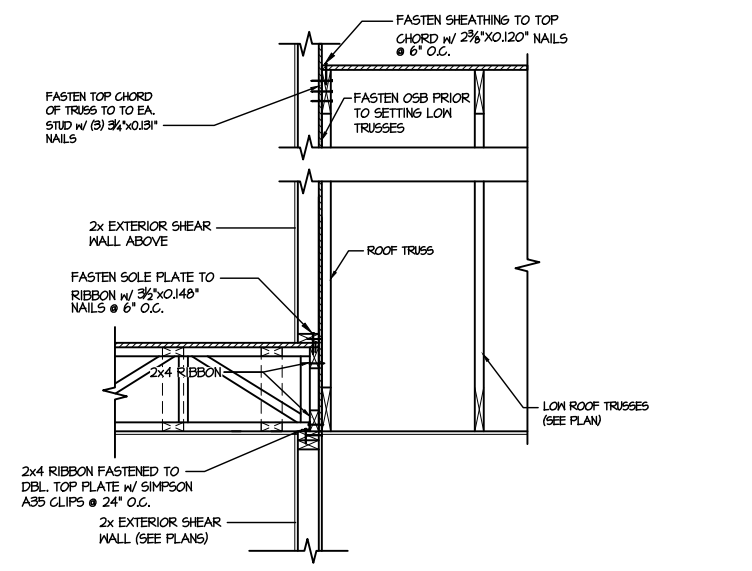

8 TYPICAL SHEAR TRANSFER DETAIL BETWEEN FLOORS @ INTERIOR WALL  
SCALE: 3/4"=1'-0"

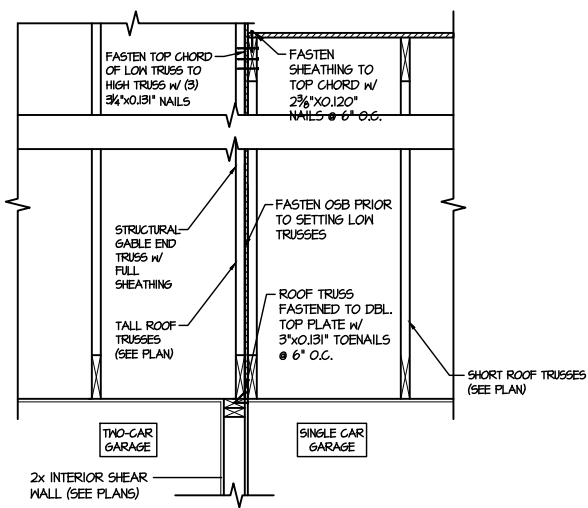

9 TYPICAL SHEAR TRANSFER DETAIL BETWEEN GARAGE BAYS  
SCALE: 3/4"=1'-0"

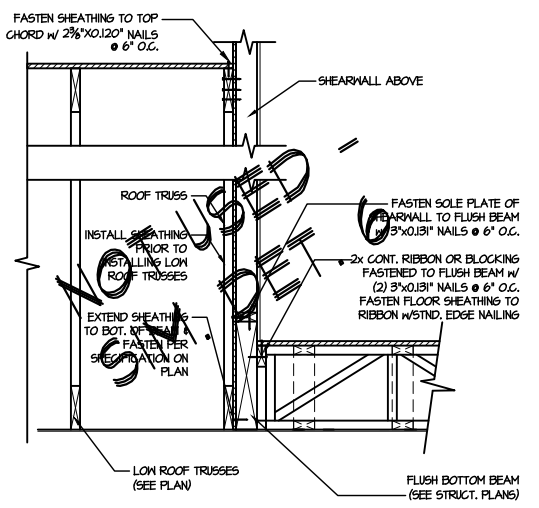

13 SHEAR TRANSFER DETAIL @ EXTERIOR SHEARWALL ABOVE  
SCALE: 3/4"=1'-0"

FILE: RLH - Drayton - Structural DATE: 6/28/2021 2:49 PM

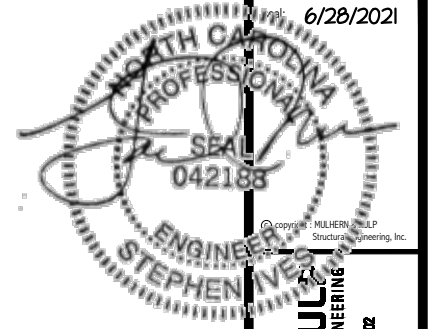

MULHERN+KUL

MULHERN+KUL  
RESIDENTIAL STRUCTURAL ENGINEERING  
300 Riverside Ave., Building 4 - Asheville, PA 18002  
P 715-646-8071 - mulhern@mkp.com  
N.C.L.C. #53823



M&K project number:  
126-21020  
project mgr: JTR  
drawn by: KL  
issue date: 06-12-21  
REVISIONS:  
date: initial:



FRAMING DETAILS  
DRAYTON  
RALEIGH, NC

sheet:  
SD2.2

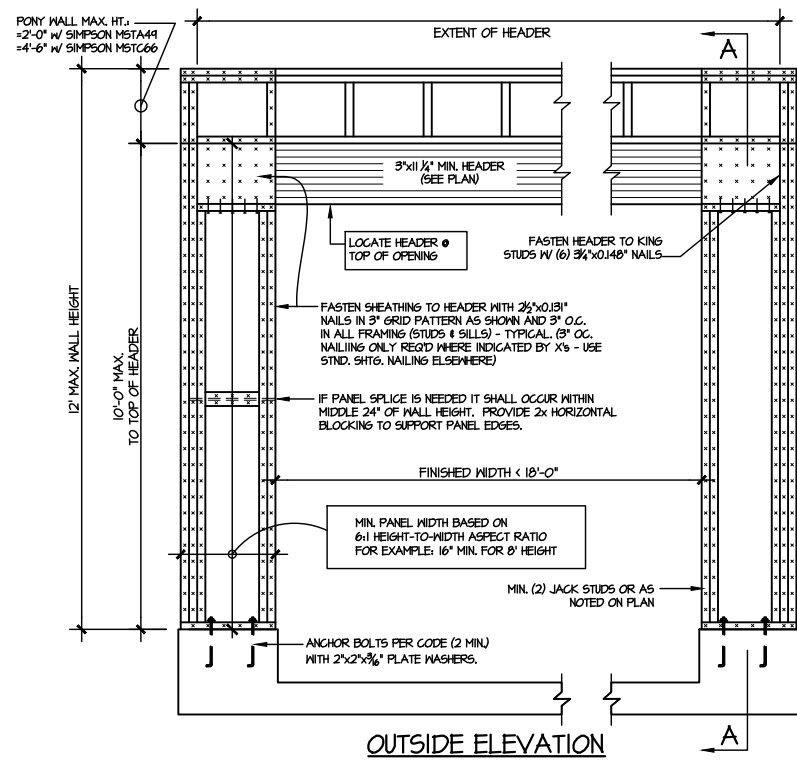

OUTSIDE ELEVATION

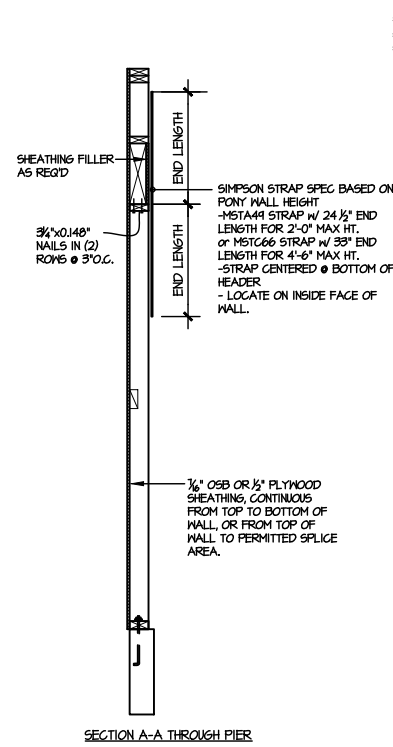

SECTION A-A THROUGH PIER

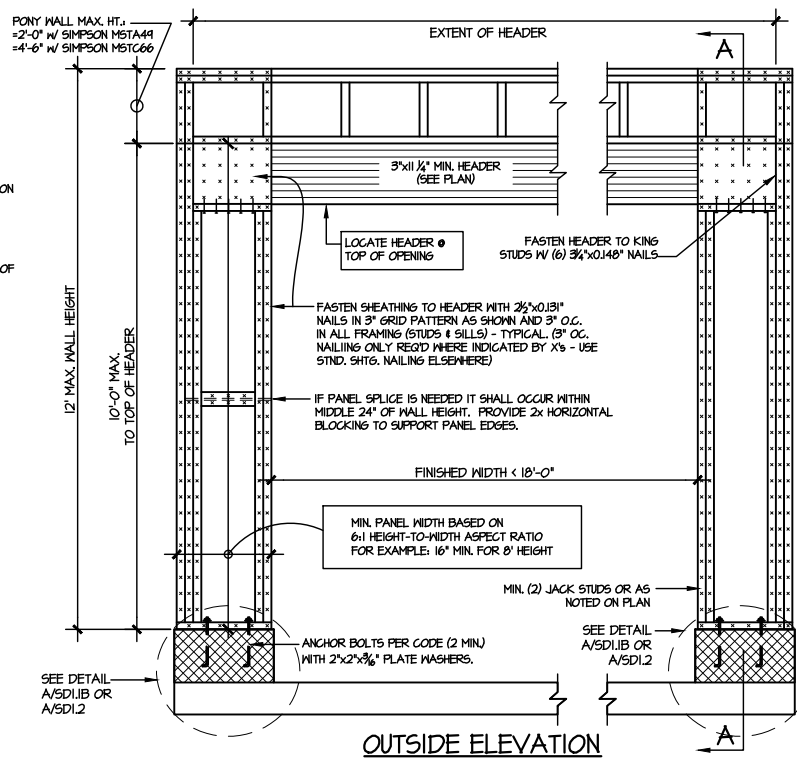

OUTSIDE ELEVATION

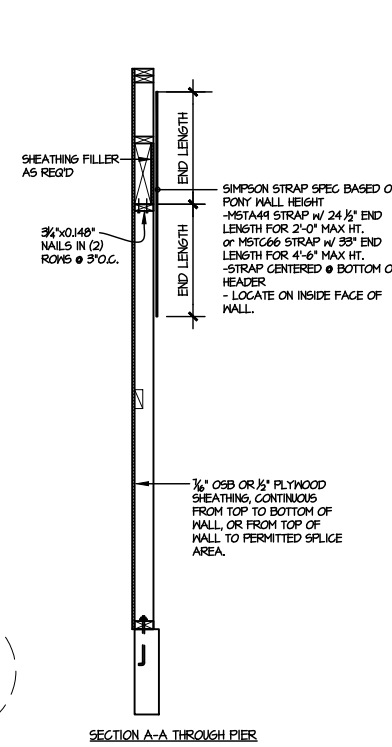

SECTION A-A THROUGH PIER

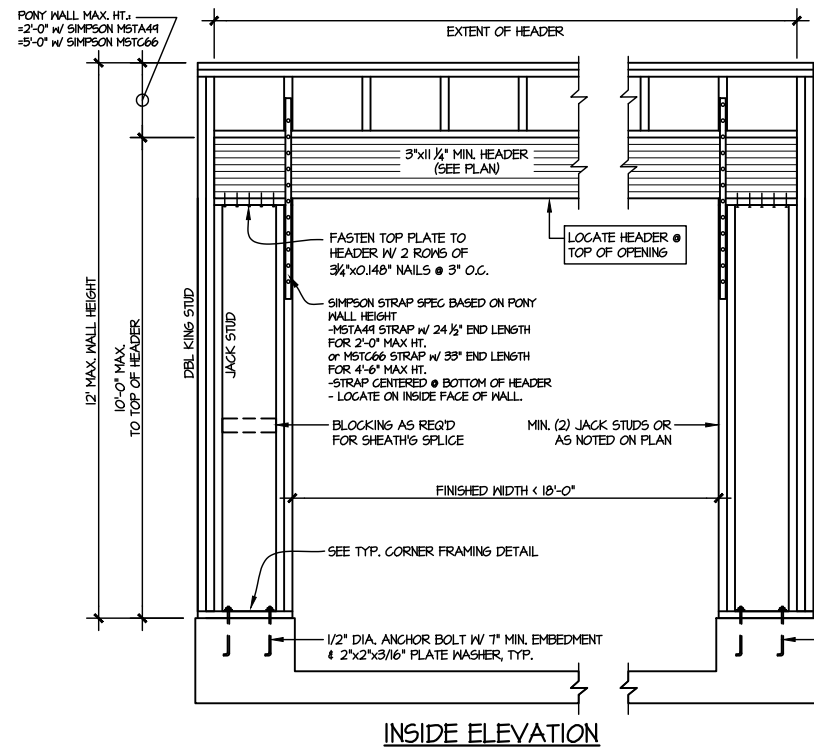

INSIDE ELEVATION

NOTE: ALL SHEATHABLE AREAS OF EXTERIOR WALL SHALL BE FULLY SHEATHED WITH 1/2" PLYWOOD OR 3/8" OSB

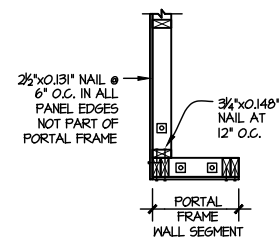

PLAN VIEW OF CORNER DETAIL

ALTERNATIVES TO 1/2" DIA. ANCHOR BOLT:  
1) 1/2" DIA. x 6" LONG SIMPSON TITEN HD  
2) 1/2" DIA. THREADED ROD EPOXY SET  
w/4 1/2" EMBED. (MIN) UTILIZING HILTI HY200 EPOXY ANCHORING SYSTEM (OR EQUAL)

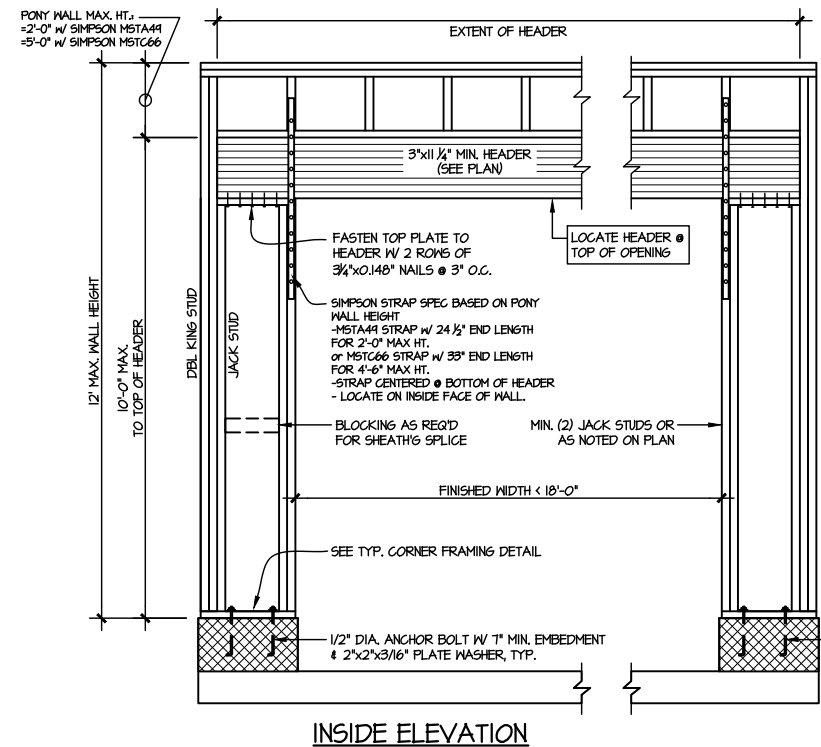

INSIDE ELEVATION

NOTE: ALL SHEATHABLE AREAS OF EXTERIOR WALL SHALL BE FULLY SHEATHED WITH 1/2" PLYWOOD OR 3/8" OSB

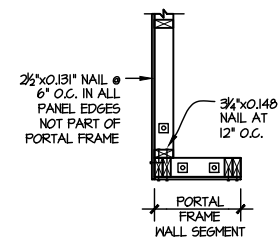

PLAN VIEW OF CORNER DETAIL

ALTERNATIVE TO 1/2" DIA. ANCHOR BOLT:  
1) 1/2" DIA. THREADED ROD EPOXY SET  
w/4 1/2" EMBED. (MIN) UTILIZING HILTI HY200 EPOXY ANCHORING SYSTEM (OR EQUAL)

TWO SIDED GARAGE PORTAL FRAME BRACING  
ELEVATION ON CONCRETE STEM

SCALE: N.T.S.

TWO SIDED GARAGE PORTAL FRAME BRACING  
ELEVATION ON CMU STEM

SCALE: N.T.S.



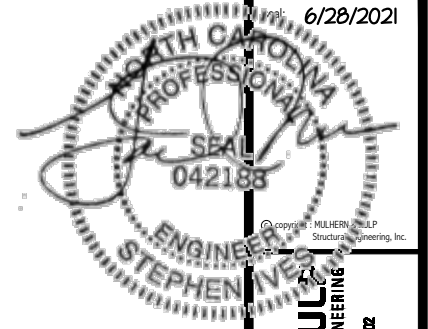

MULHERN+KUL  
RESIDENTIAL STRUCTURAL ENGINEERING  
300 Riverside Ave. Building 4 - Asheville, PA 18002  
P 215-646-5071 - mulhernmkp.com  
N.C. REG. #53825



M&K project number:  
126-21020

project mgr: JTR  
drawn by: KL  
issue date: 06-12-21

REVISIONS:  
date: initial:



FRAMING DETAILS  
DRAYTON  
RALEIGH, NC

sheet:  
**SD3.0**

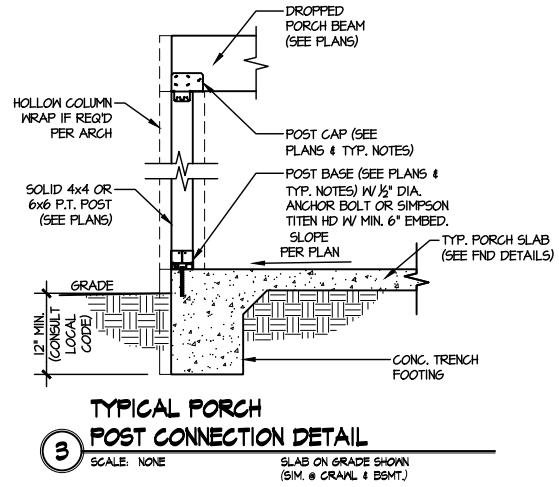
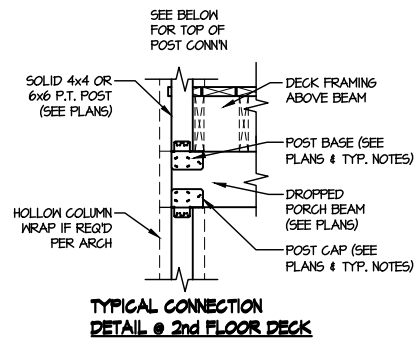

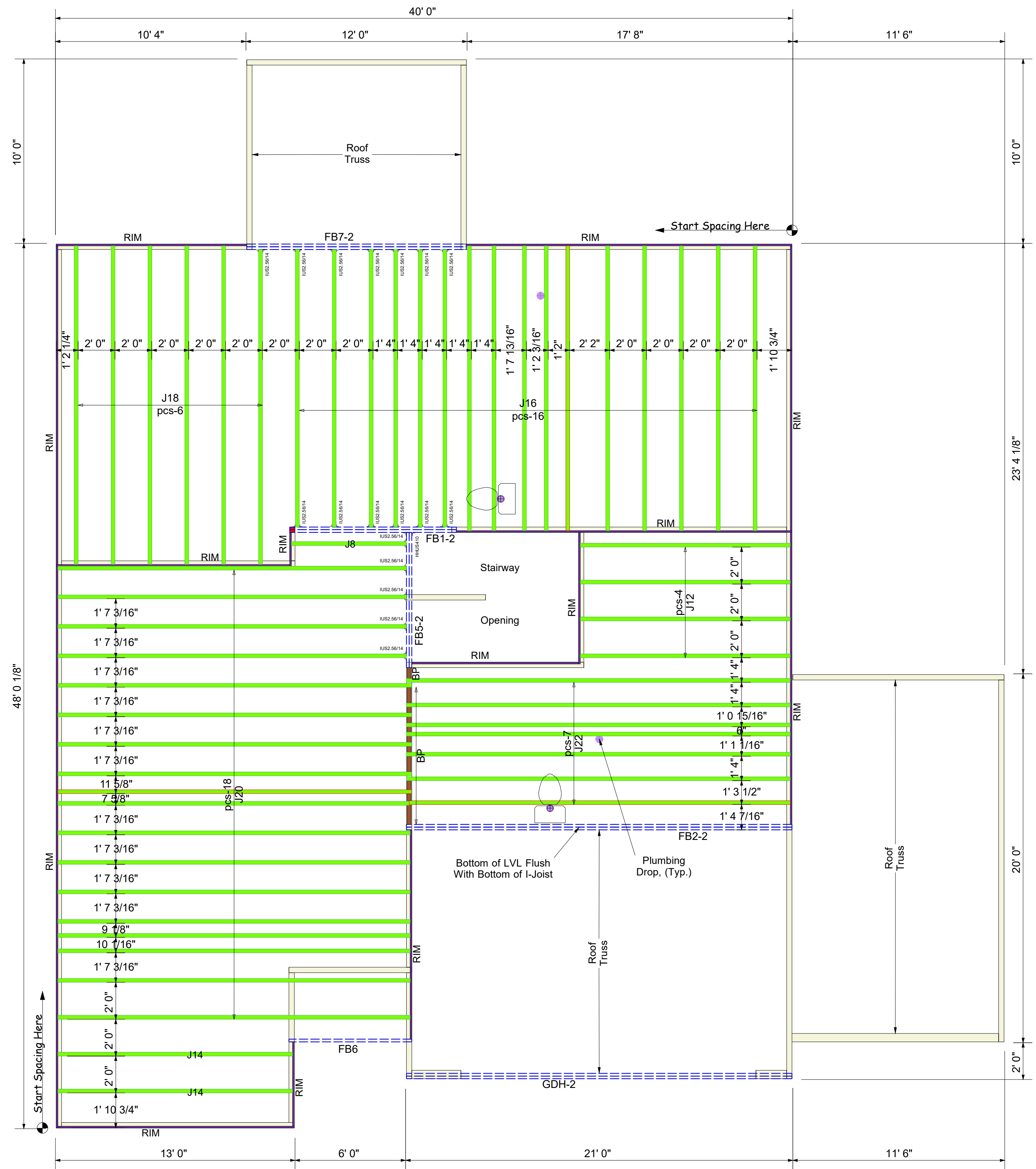
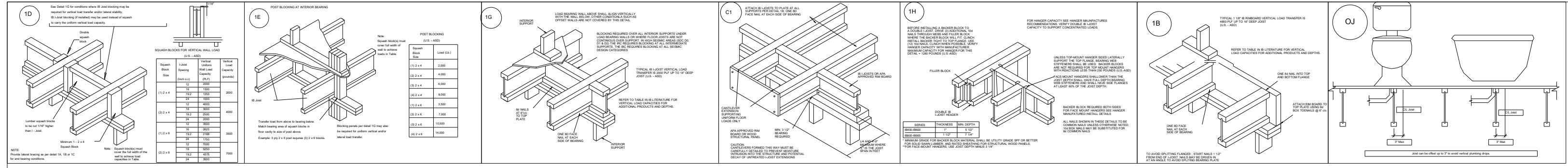

Connector Summary		
Qty	Manuf	Product
1	Simpson	HHUS410
18	Simpson	IUS2.56/14

PlotID	Length	Product	Products		
			Piles	Net Qty	Fab Type
J22	22' 0"	14" PJI-40	1	7	MFD
J20	20' 0"	14" PJI-40	1	18	MFD
J18	18' 0"	14" PJI-40	1	6	MFD
J16	16' 0"	14" PJI-40	1	16	MFD
J14	14' 0"	14" PJI-40	1	2	MFD
J12	12' 0"	14" PJI-40	1	4	MFD
J8	8' 0"	14" PJI-40	1	1	MFD
GDH-2	22' 0"	2.0 RigidLam DF LVL 1-3/4 x 11-7/8	2	2	FF
FB7-2	12' 0"	2.0 RigidLam DF LVL 1-3/4 x 14	2	2	FF
FB1-2	10' 0"	2.0 RigidLam DF LVL 1-3/4 x 14	2	2	FF
FB6	8' 0"	2.0 RigidLam DF LVL 1-3/4 x 14	1	1	FF
FB5-2	8' 0"	2.0 RigidLam DF LVL 1-3/4 x 14	2	2	FF
FB2-2	22' 0"	2.0 RigidLam DF LVL 1-3/4 x 20	2	2	FF
RIM	12' 0"	1 1/8" x 14" APA Rim Board	1	16	FF
BP	2' 0"	14" PJI-40	1	3	FF

BLOCK SOLID UNDER ALL POST /POINT LOADS FROM ABOVE - TYPICAL AT ALL LOCATIONS

2nd Floor I-Joist  
DRAWING SCALE : NTS

PROJECT NUMBER <b>22030203</b>	REVISIONS	
SHEET NUMBER <b>1 / 1</b>	DATE 03.25.22	BY RKW

**Dan Ryan Builders**  
96 Farm at Neills Creek (Drayton 3-GRFE)  
2nd FLOOR I-JOIST PLACEMENT PLAN

**Kempsville**  
Building Materials  
A Division of the Carter Lumber Company

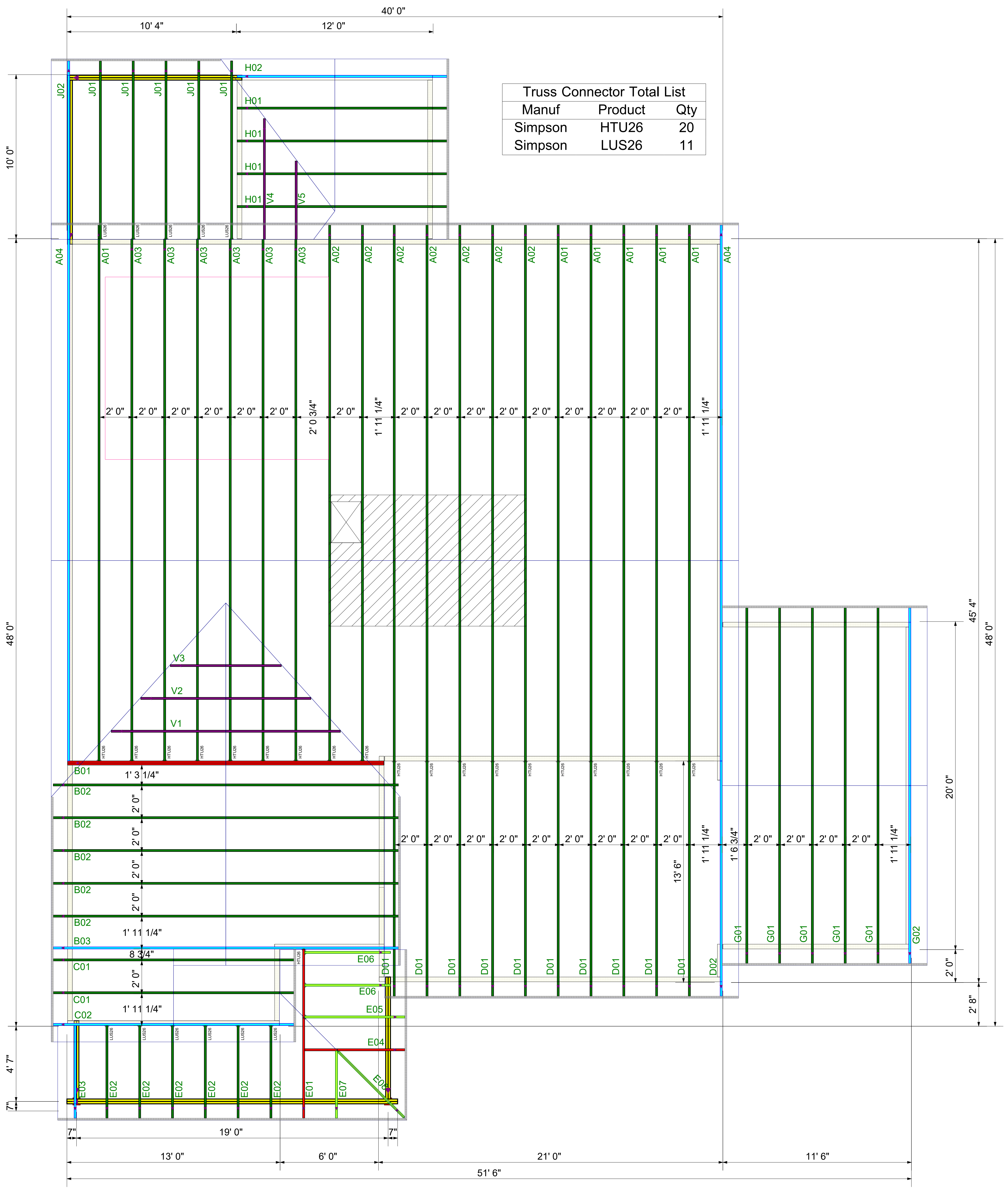

Truss Connector Total List		
Manuf	Product	Qty
Simpson	HTU26	20
Simpson	LUS26	11

**ROOF LAYOUT**  
DRAWING SCALE : NTS

PROJECT NUMBER <b>22030203</b>	REVISIONS	
SHEET NUMBER <b>1 / 1</b>	DATE 4-8-22	BY ND

<b>DRB GROUP</b>	
<b>DRAYTON 3 - 96 FARM AT NEILLS CREEK</b>	
<b>ROOF TRUSS LAYOUT</b>	

