

Harnett County Department of Public Health Improvement Permit

A building permit cannot be issued with only an Improvement Permit

ISSUED TO: GLENWOOD BUILDERS LLC PROPERTY LOCATION: 50 TALBERT DR (BALL ROAD - SR 1450)
 SUBDIVISION HIDDEN VALLEY LOT # 41
 NEW REPAIR EXPANSION Site Improvements required prior to Construction Authorization Issuance:
 Type of Structure: 54x50(4bed/3.5ba)
 Proposed Wastewater System Type: 25% REDUCTION SYS
 Projected Daily Flow: 480 GPD
 Number of bedrooms: 4 Number of Occupants: 8 max
 Basement: Yes No
 Pump Required: Yes No May be required based on final location and elevations of facilities
 Type of Water Supply: Community Public Well Distance from well NA feet Permit valid for: Five years
 No expiration
 Permit conditions: SL 2018-114 Section 11. (c) proposal by Michael G. Wood, LLS

Authorized State Agent: [Signature] Date: 07/14/2022 SEE ATTACHED SITE SKETCH
 The issuance of this permit by the Health Department in no way guarantees the issuance of other permits. The permit holder is responsible for checking with appropriate governing bodies in meeting their requirements. This site is subject to revocation if the site plan, plat, or the intended use changes. The Improvement Permit shall not be affected by a change in ownership of the site. This permit is subject to compliance with the provisions of the Laws and Rules for Sewage Treatment and Disposal and to conditions of this permit.

Construction Authorization (Required for Building Permit)

The construction and installation requirements of Rules .1950, .1952, .1954, .1955, .1956, .1957, .1958, and .1959 are incorporated by references into this permit and shall be met. Systems shall be installed in accordance with the attached system layout.

ISSUED TO: GLENWOOD BUILDERS LLC PROPERTY LOCATION: 50 TALBERT DR (BALL ROAD - SR 1450)
 SUBDIVISION HIDDEN VALLEY LOT # 41
 Facility Type: 54x50(4bed/3.5ba) New Expansion Repair
 Basement? Yes No Basement Fixtures? Yes No
 Type of Wastewater System** 25% REDUCTION SYSTEM (Initial) Wastewater Flow: 480 GPD
 (See note below, if applicable) 50% REDUCTION PPBPS SYS (Repair)
 Installation Requirements/Conditions
 Septic Tank Size 1000 gallons Exact length of each trench MULTI feet Trench Spacing: 9 Feet on Center
 Pump Tank Size 1000 gallons Trenches shall be installed on contour at a Soil Cover: 7 inches
 Maximum Trench Depth of: 19 inches (Maximum soil cover shall not exceed
 (Trench bottoms shall be level to +/-1/4" 36" above the trench bottom)
 in all directions)
 Pump Requirements: _____ ft. TDH vs. _____ GPM Aggregate Depth: NA inches below pipe
NA inches above pipe
 Conditions: SL 2018-114 Section 11. (c) proposal by Michael G. Wood, LLS NA inches total

**WATER LINES (INCLUDING IRRIGATION) MUST BE 10FT. FROM ANY PART OF SEPTIC SYSTEM OR REPAIR AREA.
NO UTILITIES ALLOWED IN INITIAL OR REPAIR DRAIN FIELD AREA.**

**If applicable: I understand the system type specified is different from the type specified on the application. I accept the specifications of this permit.

Owner/Legal Representative Signature: _____ Date: _____

This Construction Authorization is subject to revocation if the site plan, plat, or the intended use changes. The Construction Authorization shall not be transferred when there is a change in ownership of the site. This Construction Authorization is subject to compliance with the provisions of the Laws and Rules for Sewage Treatment and Disposal and to the conditions of this permit. SEE ATTACHED SITE SKETCH

Authorized State Agent: [Signature] Date: 07/14/2022
ANDREW CURRIE Construction Authorization Expiration Date: 07/14/2027

Harnett County Department of Public Health Site Sketch

Property Location: 50 TALBERT DR (BALL ROAD - SR 1450)

Issued To: GLENWOOD BUILDERS LLC

Subdivision: HIDDEN VALLEY

Lot # 41

Authorized State Agent: _____

Date: 07/14/2022

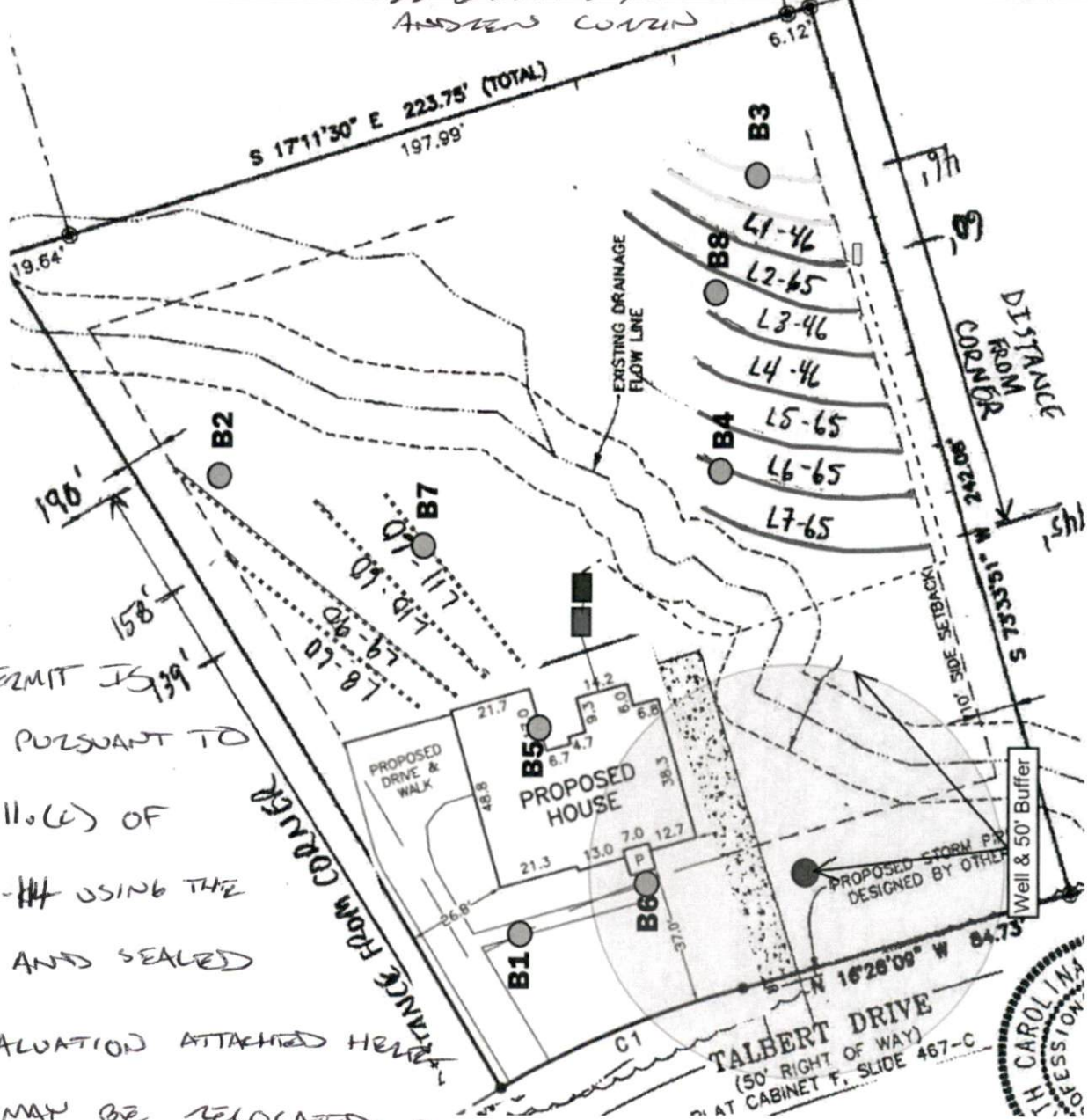

* THIS PERMIT IS ISSUED PURSUANT TO SECTION 11.06 OF SL 2018-114 USING THE SIGNED AND SEALED LSS EVALUATION ATTACHED HEREIN

* TANKS MAY BE RELOCATED BASED ON PLUMBING LOCATION - SIDE YARD [LIGHT] @ LOCATION OF ORIGINAL DRIVEWAY IS AVAILABLE

This drawing is for illustrative purposes only. System installation must meet all pertinent laws, rules, and regulations.

Glenwood Builders
215 Progress Drive
Fuquay Varina, Nc 27526
Phone (910) 868-4202
ron@glenwoodbuilders.net

Property Information

Project Name	Krishnan Vaishnavi
Site Address	50 Talbert Dr. Holly Spring, NC 27540
S/D Name and Lot #	Lot#41 Hidden Valley PH#1 PC#F-567C
PIN	0625-33-4823.000
Size (Acre)	1.06
County	Harnett Co.

APPLICATION INFORMATION

NAME	GLENWOOD BUILDERS
MAILING ADDRESS	215 PROGRESS DR. FUQUAY VARINA, NC 27526
PHONE NUMBER	919-868-4202
E-MAIL ADDRESS	RON@GLENWOODBUILDERS.NET

The LSS Evaluation attached to this application is to be used to produce, design, and construct features for permitting accordance with SL2018-114 Section 11.(c).

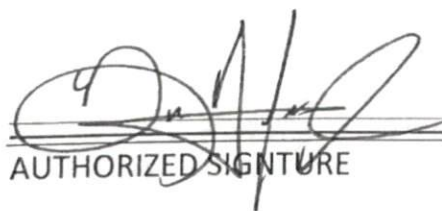

A handwritten signature in black ink, appearing to be 'Ron Vaishnavi', written over a horizontal line.

AUTHORIZED SIGNATURE

President

TITLE

7/13/2022

DATE

**Residential Subsurface Wastewater
Treatment and Disposal System Proposal**

for

**Lot 41 – Hidden Valley
50 Talbert Drive
Holly Springs, Harnett County, NC**

Tax Parcel #0625-33-4823
July 6, 2022

Prepared for:

Ben Stone
Build Atmos
223 South West Street, Suite 10018
Raleigh, NC 27610
stone@buildatmos.com

Prepared by:

Michael G. Wood, LSS
620 Lee Fox Lane
Hillsborough, NC 27278
Phone: 919-417-8027
Mgw4343334@gmail.com



The LSS Evaluation attached to this application is to be used to produce design and construction features for permitting in accordance with SL 2018-114 Section 11.(c).

Details

Build Atmos has contracted with Michael Wood, LSS to prepare Session Law 2018-114 Section 11 (c) septic proposal for the 4-bedroom single family residence on Lot 41 Hidden Valley located at 50 Talbert Drive, Harnett County, North Carolina.

Based upon the soils investigation by Michael Wood, it has been determined that a sufficient amount of “Suitable” Group IV soils is available for the installation of Pump-to **Accepted System** with a 25% reduction for the initial system at a 0.30 GPD/ft. sq. long term acceptance rate (LTAR). The repair will be a Horizontal – Prefabricated Permeable Block Panel System (H-PPBPS) at a 0.3 LTAR. The property is served by private well.

Build Atmos requests that Harnett County Environmental Health issue the appropriate permits for a subsurface wastewater treatment and disposal system based upon the following proposal and the enclosed Licensed Soil Scientist Evaluation, which is being submitted pursuant to and meets the requirements of SL 2018-114 Section 11. (c).

Location

From Lillington, Main Street north to intersection with W Cornelius Harnett Blvd. Left onto W Cornelius Harnett Blvd (US 401) for 4.4 miles, then left onto Christian Light Road for 4.4 miles, then left onto Cokesbury Road. In 3.6 miles, left on Ball road, left onto Hidden Valley Drive in 1.3 miles, then first right onto Talbert Drive. Lot 41 will be on right in 312 feet.

References

Laws and Rules for Sewage Treatment and Disposal Systems, 15A NCAC 18A, Section .1900, Department of Environment and Natural Resources, Division of Environmental Health, On-site Wastewater Section, December 6, 2018.

Accepted Wastewater System No. AWWS-2005-02-R6; North Carolina Department of Environment and Natural Resources, Division of Environmental Health, On-Site Wastewater Section, August 21, 2015.

Primary Investigator’s Credentials

NC Licensed Soil Scientist No. 1219
SC Professional Soil Classifier No. 114

Plans and Specifications

A. Septic Tank

1. The septic tank shall be State approved (Section .1953 of 15A NCAC 18A), watertight, structurally sound, and 1,000 gallons in capacity.
2. The septic tank will be fitted with an approved effluent filter and riser for easy access and periodic maintenance.
3. It is the responsibility of the septic contractor to thoroughly inspect the septic tank prior to accepting delivery to assure that the tank has had time to properly cure and is free of cracks or other structural deficiencies.

B. Pump Tank

1. The pump tank shall be State approved, of one-piece construction, watertight, structurally sound and 1,000 gallons capacity. Again, it is the responsibility of the septic tank contractor to thoroughly inspect each pump tank prior to accepting delivery.
2. All pipe penetrations into the tank shall be booted (i.e., C-293 boot with a stainless-steel strap).
3. The pump tank shall have access risers that extend, at a minimum, 6 inches above finished grade and must have less than 36 inches of fill over its top once finished grade has been established (a reinforced concrete tank will be required if finished soil cover is 36 inches or greater in depth).
4. Floats, pump and control circuits, and the control panel shall meet the requirements of Rule .1952(c). Panel and control equipment shall include lightning protection, be protected from unauthorized access, and always remain accessible to the system operator.
5. The pump and alarm controls shall be provided with manual circuit disconnects within a watertight, corrosion resistant, NEMA 4x rated control panel. The control panel must be securely mounted outside, adjacent to the pump tank riser and at a minimum of 12 inches above finished grade. Pump and float control wiring should be long enough to reach from the tank to the control panel without splicing, routed through wire conduit, and sealed at the openings within the pump tank as well as the control panel enclosure. It is paramount that the conduit is properly sealed to prevent the escape of flammable gases from the pump tank. Furthermore, there must be two electrical circuits for the pump tank controls: one for the pump and one for the alarm controls.
6. Float switch tie downs must be made of a corrosion resistant material (per OWPS, all metal in the tanks shall be stainless steel). Floats should be mounted on a separate “float tree” rather than the pump supply line (see pump tank detail).
7. The pump removal system will be via a pump tether made of nylon rope or its equivalent. The tether material should be resistant to mildew and rot.

C. Pipes and Fittings

1. All discharge piping, connectors and supply lines should be made of SCH 40 PVC.

2. All joints must be properly “welded” utilizing the appropriate PVC cement for each application.
3. The supply line from the pump tank to the pressure manifold shall be 2-inch Schedule 40 PVC (supply line is approximately 190 feet).
4. There shall be a threaded PVC union above each pump to facilitate easy removal of the pumps for maintenance or replacement.

D. Distribution Method – Pressure Manifold

1. The system will be fed by a pressure manifold.
2. The pressure manifold shall be contained within an adequately sized box/vault that will allow future repair lines to be installed and is designed to allow for drainage of effluent that may accumulate in it during flushing and head pressure adjustments. The box should be placed upon a gravel base.
3. A gate valve shall be provided at the pressure manifold box to allow for final pressure adjustment (2 foot of head pressure as per design).
4. The pressure manifold shall be constructed of SCH 80 PVC.
5. There shall be 7 taps; (3) 1/2in SCH 80 and (4) 1/2in SCH 40
6. The connecting pipe between the pressure manifold taps and the drainfield shall be constructed of PVC.

E. Drainfield Installation

1. The drainfield has been previously laid out on-site utilizing metal stemmed flags. The property owner/builder should mark this area and isolate it as much as possible from construction traffic
2. Under no circumstances shall any construction take place within the drainfield area while the soil is in a wet condition.
3. The specified system the shallow placed innovative wastewater system Infiltrator Quick4 Chamber System.
4. The drainfield consists of seven (7) lateral trenches 3-foot wide and 46, 46, 46, 65, 66, 66, and 65’ long.
5. The trench depth for this system shall be **19-inches on the low side of trench.**
6. The laterals are to be installed on contour with the land, keeping the individual trench bottoms level from beginning to end.
7. The trenches should be left open for the final inspection by the County.
8. Each trench shall be placed on a minimum of 9-foot on centers.

Initial System - Lot 41 Hidden Valley						
Field Line #	Color	Initial/Repair	Field Length	System Length	Setup #1	Relative Elevation
1	Blue	Initial	53	46	8.83	98.3
2	White	Initial	65	65	9.91	97.2
3	Pink	Initial	46	46	10.81	96.3
4	Blue	Initial	48	46	12.2	94.9
5	White	Initial	79	66	7.2	99.9
6	Pink	Initial	88	66	8.55	98.6
7	Blue	Initial	65	65	10.37	96.7
Benchmark = PIN back right corner					7.1	100
Repair System - Lot 41 Hidden Valley						
8	Blue	Initial	60	46	7.77	97.8
9	White	Initial	90	65	9.55	96.0
10	Pink	Initial	60	46	11.1	94.4
11	Blue	Initial	60	46	13	92.5
Benchmark = PIN front left corner					5.54	100

F. Final Landscaping

1. Final cover over the drainfield shall be at least 6-inches deep. Additional soil cover may be required to achieve the 6-inch requirement.
2. The drainfield shall be shaped to shed rainwater and be free from low spots.
3. The entire area of the drainfield should be planted with grass as soon as possible to prevent erosion. The soil should be properly tilled, limed (if necessary) and fertilized prior to planting. After applying grass seed, the area should be heavily mulched with straw or other suitable material.

G. Utility/Drive Conflicts

1. The builder and property owner must take special care in planning for utilities (water, power, gas, telephone, cable lines, etc.). All utilities shall be kept clear of the septic system and its proposed repair area. Improper planning for underground utilities can negatively impact the installation and, in some cases, cause irreparable damage and permit revocation. If there are any questions regarding preferred routes, contact the County as soon as possible.
2. Water lines must be kept at least ten (10) feet from any portion of the septic system.
3. Irrigation systems should not be placed in the drain field area.

Maintenance

H. In General

The designed system does not require ongoing maintenance via a person certified (Certified Subsurface System Operator) by the North Carolina Department of Environment and Natural Resources to operate subsurface wastewater systems (Section .1961 Maintenance of Sewage Systems). However, the following maintenance should be considered by the owner.

1. The homeowner must maintain the drainfield area through periodic mowing. The drainfield must not be allowed to become overgrown.
2. The septic tank should be pumped every 4 years or when the solids within the septic tank reach an elevation that is equivalent to 25% of the volume of the tank. In some situations, the tanks may need to be pumped more frequently. If you are using a garbage disposal, it is recommended that the septic and pump tanks be cleaned out annually.
3. When it becomes necessary to clean the effluent filters, the filters should be removed, and the accumulated debris washed back into the septic or pump tank – not onto the lawn.
4. Any damp areas, leakages or malfunctions in the drainfield should be addressed immediately.
5. Divert gutter downspouts and surface water runoff away from the drainfield and septic and pump tanks.

Initial System Design Specifics

Daily Design Flow:	480 GPD – 3 bedroom house
Effluent Loading Rate:	0.300 GPD per sq. ft.
Drainfield Type:	Accepted (25 % Reduction)
Maximum Trench Depth:	19 Inches on low-side
Supply Size:	2 Inch
Supply Line Length:	Approximately 190 feet
Number of Drainlines:	5
**Drain Lines:	3' Wide x 46, 46, 46, 65, 66, 66, and 65' long
**Drainline Spacing:	9 Foot on Centers
Total Trench Length:	400 Linear Feet
Distribution Method:	Pressure Manifold
Number of Taps:	7
Dosing Volume:	169 Gallons
Pump Run Time:	3.77 Minutes
Pressure Head:	2 Feet
Total Elevation/Friction Head	20.71 Feet
*Pump Requirements:	44.88 GPM at 20.71 Feet TDH
Recommended Pump:	Goulds Pump WE03M or equiv.

* Total Dynamic Head (TDH) for system is estimated based upon existing elevations, approximate pump off elevation, design pressure head and supply line length. Total Dynamic Head should be reconfirmed by septic contractor at the time of system installation based upon actual tank depth and pressure manifold height.

** See drainfield layout for site locations and more details.

Figure 1. Lot 41 Hidden Valley

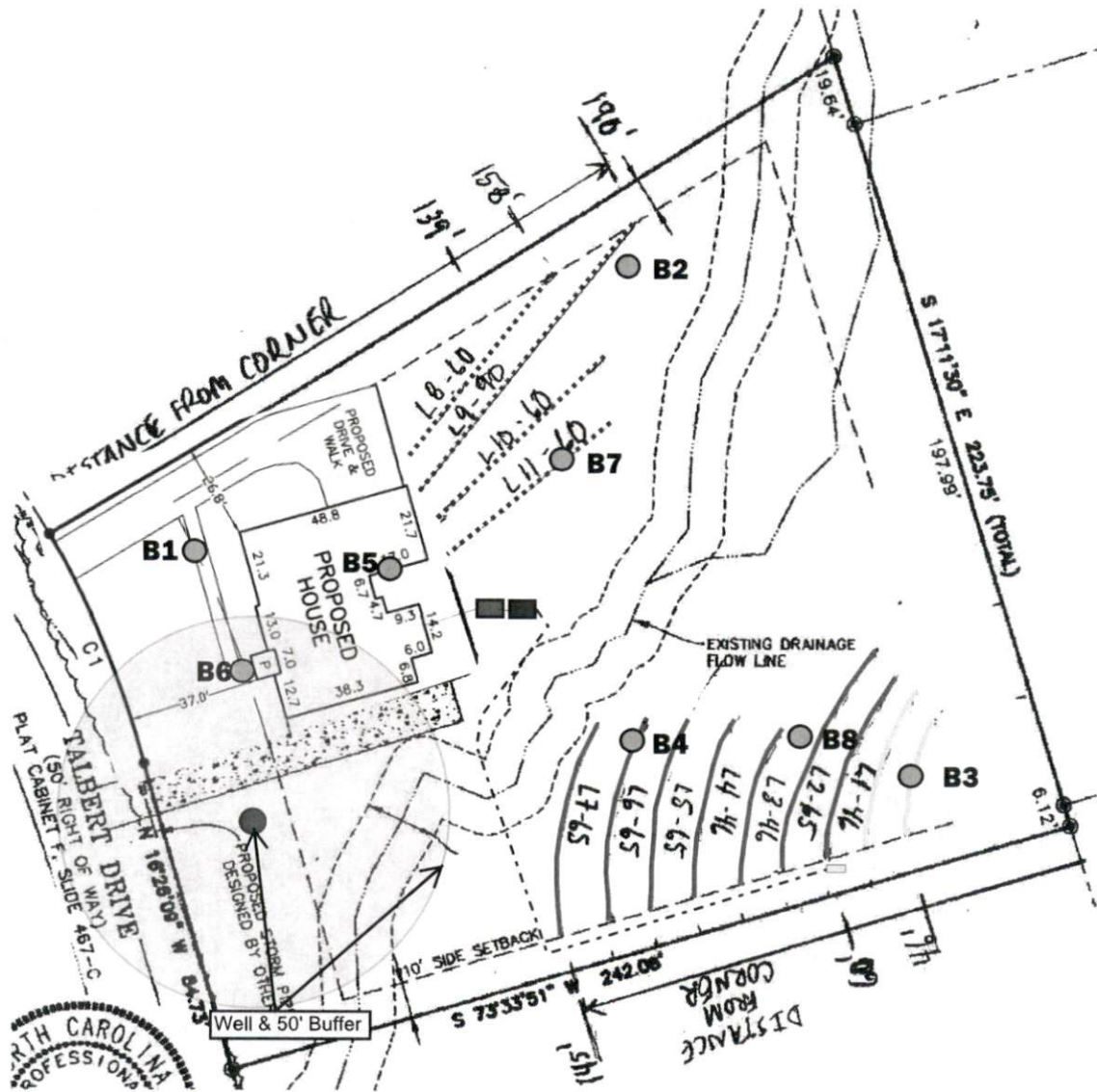

NORTH CAROLINA PROFESSIONAL



- Initial Drainlines
- - - Extra Drainlines
- ⋯ Repair Drainlines
- · - · ~190' Supply Line
- Septic Tank
- Pump Tank
- Pressure Manifold
- Soil Boring
- 1"=50'



Repair System Design Specifics

Effluent Loading Rate:	0.30 GPD per sq. ft.
Drainfield Type:	H-PPBPS (50 % Reduction)
Installation Trench Depth:	17 Inches on low-side
Number of Drainlines:	4
**Drain Lines:	4' Wide x 60, 90, 60, and 60' Long
**Drainline Spacing:	9 Foot on Centers
Total Trench Length:	270 Linear Feet
** See drainfield layout for site locations and more details.	

Michael G. Wood, LSS
620 Lee Fox Lane
Hillsborough, NC 27278

PROPERTY ID #: 0625-33-4823
COUNTY: HARNETT

LOT 41 HIDDEN VALLEY
SOIL/SITE EVALUATION
for ON-SITE WASTEWATER SYSTEM

OWNER: KRISHNAN VAISHNAVI
ADDRESS: 50 TALBERT DR., HOLLY SPRINGS, NC 27540
PROPOSED FACILITY: RES PROPOSED DESIGN FLOW (.1949): 480
LOCATION OF SITE: 50 TALBERT DR., HOLLY SPRINGS, NC
WATER SUPPLY: Private Public Well Spring Other
EVALUATION METHOD: Auger Boring Pit Cut

DATE EVALUATED: DEC 2021
PROPERTY SIZE: 1.06
PROPERTY RECORDED:

TYPE OF WASTEWATER: Sewage Industrial Process Mixed

P R O F I L E #	.1940 LANDSCAPE POSITION/ SLOPE %	HORIZON DEPTH (IN.)	SOIL MORPHOLOGY (.1941)		OTHER PROFILE FACTORS				PROFILE CLASS & LTAR
			.1941 STRUCTURE/ TEXTURE	.1941 CONSISTENCE/ MINERALOGY	.1942 SOIL WETNESS/ COLOR	.1943 SOIL DEPTH	.1956 SAPRO CLASS	.1944 RESTR HORIZ	
1	LS/9	0-12	GR/VGRSL	VFR/NE	-	32	32	-	PS 0.3
		12-23	SBK/SC	FI/SE					
		23-32	SBK/SCL	FR/SE					
		32+	M/SCL	FR/SE					
2	LS/11	0-4	GR/GRSL	VFR/NE	-	35	35	-	PS 0.3
		4-26	SBK/C	FI/SE					
		29-35	SBK/SC	FR/SE					
		35+	M/SC	FI/SE					
3	LS/6	0-10	GR/GRSL	VFR/NE	-	>36	-	-	PS 0.3
		10-36+	SBK/C	FI/SE					
4	LS/6	0-11	GR/VGRSL	VFR/NE		>33		33	PS 0.3
		11-33	SBK/SC	FI/SE					
		33+	AR						

DESCRIPTION	INITIAL SYSTEM	REPAIR SYSTEM
Available Space (.1945)	PS	PS
System Type(s)	ACCEPTED	4-PPB PS
Site LTAR	0.3	0.3

OTHER FACTORS (.1946):
SITE CLASSIFICATION (.1948): PROV. SUBST
EVALUATED BY: M. WOOD
OTHER(S) PRESENT: E. WOOD



COMMENTS:

SOIL/SITE EVALUATION

(Continuation Sheet-Complete all field in full)

Sheet 2 of 2

DEPARTMENT OF HEALTH AND HUMAN SERVICES
 DIVISION OF PUBLIC HEALTH
 ENVIRONMENTAL HEALTH SECTION
 ON-SITE WATER PROTECTION BRANCH

LOT 41 HIDDEN VALLEY

PROPERTY ID #: 0625-33-4823
 DATE OF EVALUATION: DEC. 2021
 COUNTY: HARNETT

P R O F I L E #	.1940 LANDSCAPE POSITION/ SLOPE %	HORIZ ON DEPTH (IN.)	SOIL MORPHOLOGY (.1941)		OTHER PROFILE FACTORS				PROFILE CLASS & LTAR
			.1941 STRUCTURE/ TEXTURE	.1941 CONSISTENCE/ MINERALOGY	.1942 SOIL WETNESS/ COLOR	.1943 SOIL DEPTH	.1956 SAPRO CLASS	.1944 RESTR HORIZ	
5	LS/ 9	0-12	GR/VGR SL	VFR / NE	-	>29	-	29 AR (LOCK)	PS 0.3
		12-29	SBK / C	FI / SE					
		29+	AR						
6	LS/ 9	0-13	GR/VGR SL	VFR / NE	-	>37	-	-	PS 0.3
		13-28	SBK / SC	FI / SE					
		29-37+	SBK / SCL	FR / SE					
7	LS/ 5	0-11	GR / fsl	FR / NE	10YR 6/2 31"	-	-	-	PS 0.35
		11-15	SBK/VGR SL	VFR / NE					
		15-33+	SBK / SCL	FR / SE					
8	LS/ 7	0-9	GR / GR SL	VFR / NE	-	>36	-	-	PS 0.3
		9-36+	SBK / C	FI / SE					

COMMENTS:

Michael Wood, LSS
620 Lee Fox Lane
Hillsborough, NC 27278

Lot 41 Hidden Valley

Recommended Pump Tank Design

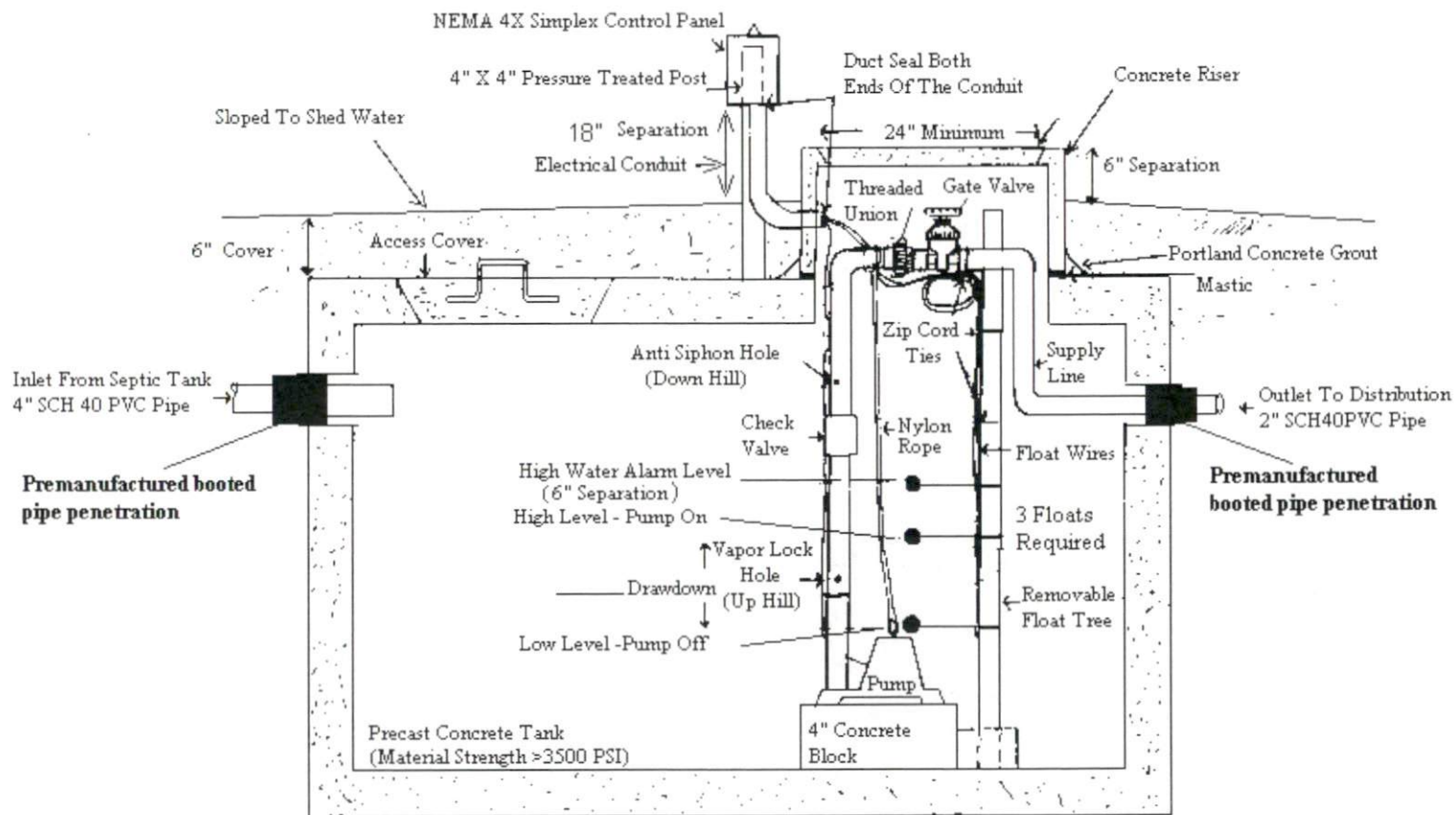

Michael Wood, LSS
 620 Lee Fox Lane
 Hillsborough, NC 27278

Lot 41 Hidden Valley

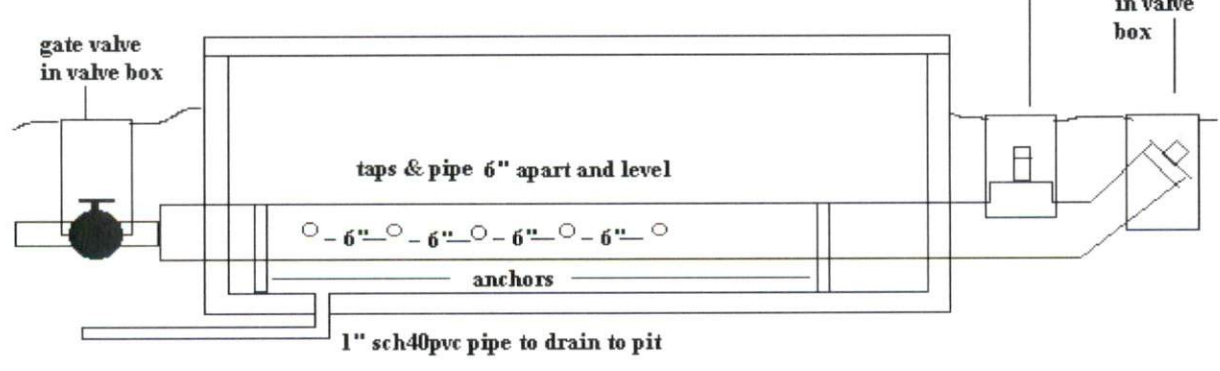
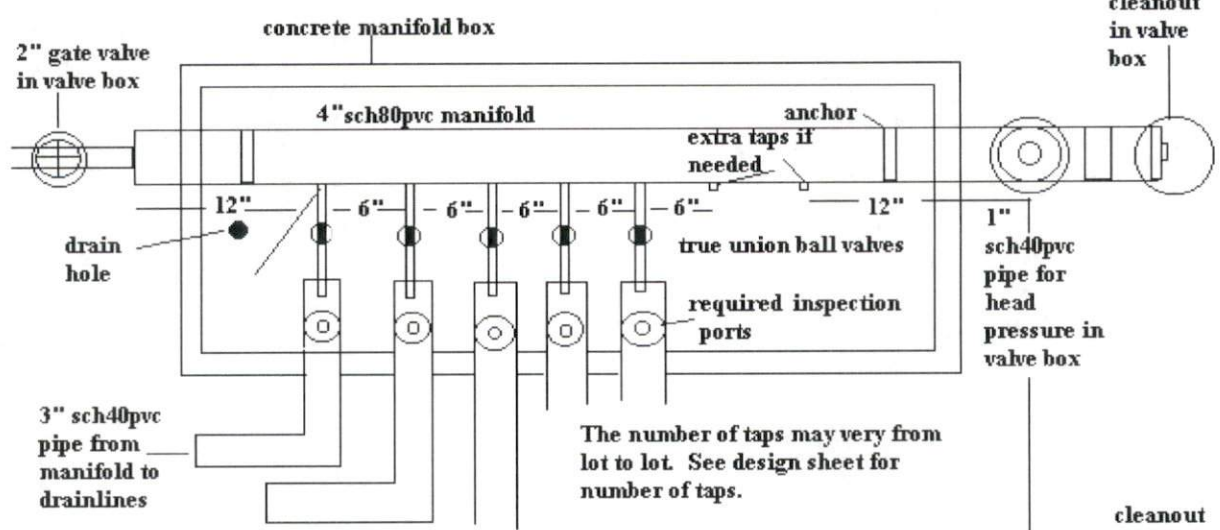
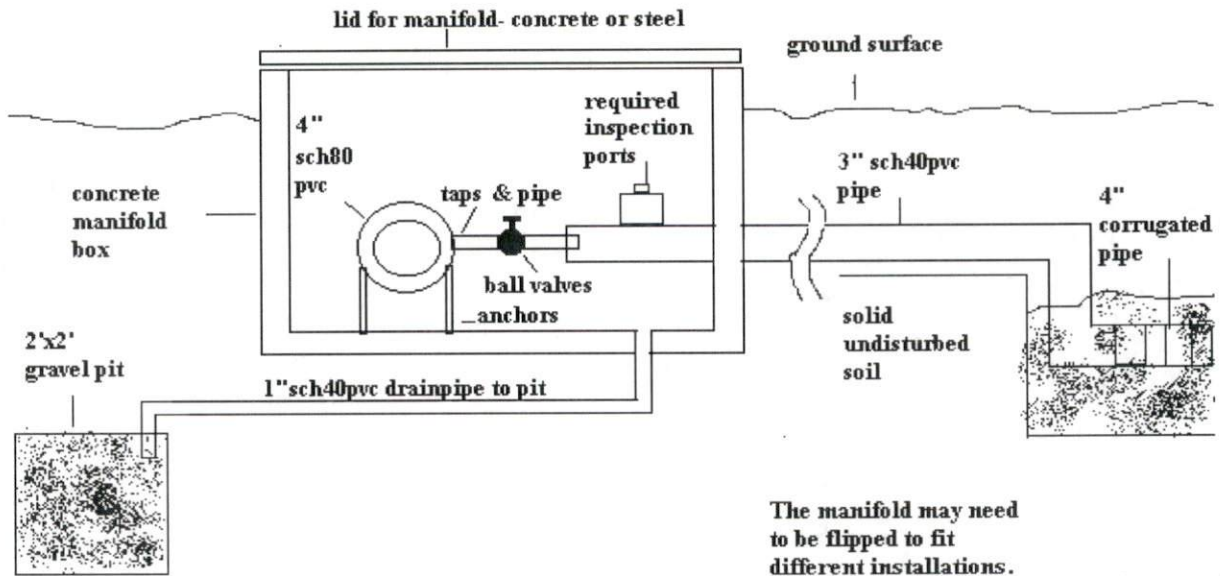



Submersible Effluent Pump

MODEL 3885

WE Series

PROSURANCE AVAILABLE FOR RESIDENTIAL APPLICATIONS.

APPLICATIONS

Specifically designed for the following uses:

- Homes
- Farms
- Trailer courts
- Motels
- Schools
- Hospitals
- Industry
- Effluent systems

SPECIFICATIONS

Pump

- Solids handling capabilities: 3/4" maximum.
- Discharge size: 2" NPT.
- Capacities: up to 140 GPM.
- Total heads: up to 128 feet TDH.
- Temperature: 104°F (40°C) continuous 140°F (60°C) intermittent.
- See order numbers on reverse side for specific HP, voltage, phase and RPM's available.

FEATURES

- **Impeller:** Cast iron, semi-open, non-clog with pump-out vanes for mechanical seal protection. Balanced for smooth operation. Silicon bronze impeller available as an option.
- **Casing:** Cast iron volute type for maximum efficiency. 2" NPT discharge.
- **Mechanical Seal:** SILICON CARBIDE VS. SILICON CARBIDE sealing faces. Stainless steel metal parts, BUNA-N elastomers.

■ **Shaft:** Corrosion-resistant, stainless steel. Threaded design. Locknut on all models to guard against component damage on accidental reverse rotation.

■ **Fasteners:** 300 series stainless steel.

■ Capable of running dry without damage to components.

■ Designed for continuous operation when fully submerged.

MOTORS

■ Fully submerged in high-grade turbine oil for lubrication and efficient heat transfer.

■ Class B insulation on 1/3-1 1/2 HP models.

■ Class F insulation on 2 HP models.

Single phase (60 Hz):

- Capacitor start motors for maximum starting torque.
- Built-in overload with automatic reset.
- SJTOW or STOW severe duty oil and water resistant power cords.
- 1/3 and 1/2 HP models have NEMA three prong grounding plugs.
- 3/4 HP and larger units have bare lead cord ends.

Three phase (60 Hz):

- Class 10 overload protection must be provided in separately ordered starter unit.
- STOW power cords all have bare lead cord ends.

■ **Designed for Continuous Operation:** Pump ratings are within the motor manufacturer's recommended working limits,

can be operated continuously without damage when fully submerged.

■ **Bearings:** Upper and lower heavy duty ball bearing construction.

■ **Power Cable:** Severe duty rated, oil and water resistant. Epoxy seal on motor end provides secondary moisture barrier in case of outer jacket damage and to prevent oil wicking. Standard cord is 20'. Optional lengths are available.

■ **O-ring:** Assures positive sealing against contaminants and oil leakage.

AGENCY LISTINGS



Tested to UL 778 and CSA 22.2 108 Standards By Canadian Standards Association File #LR38549

Goulds Pumps is ISO 9001 Registered.

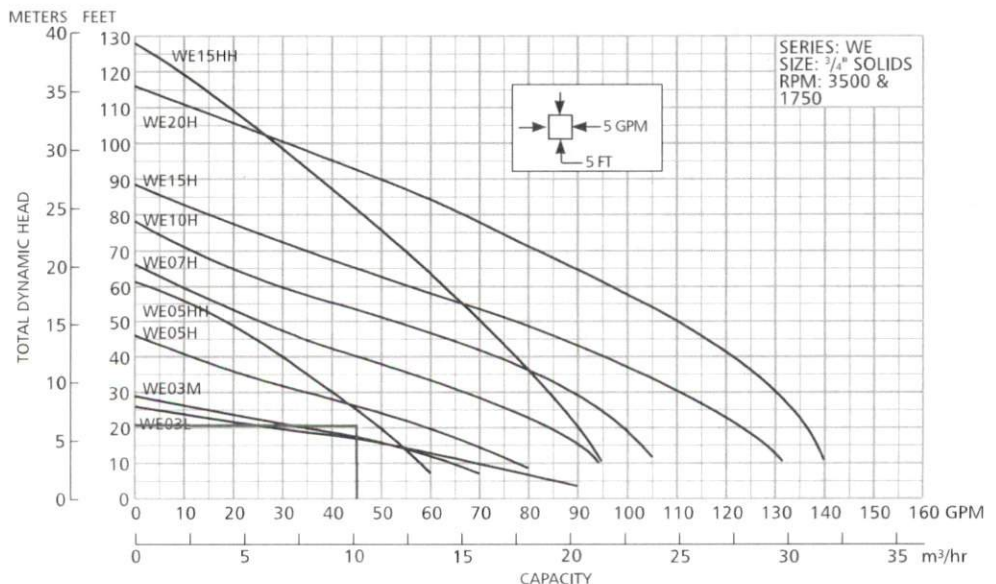

COMPONENTS

Item No.	Description
1	Impeller
2	Casing
3	Mechanical Seal
4	Motor Shaft
5	Motor
6	Ball Bearings
7	Power Cable
8	Casing O-Ring

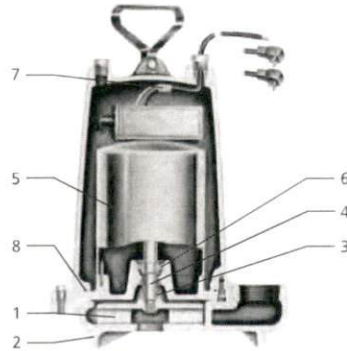

MODELS

Order No.	HP	Volts	Phase	Max. Amp.	RPM	Solids	Wt. (lbs.)
WE0311L		115		10.7			
WE0318L		208		6.8			
WE0312L		230		4.9			
WE0311M	1/3	115		10.7	1750		56
WE0318M		208	1	6.8			
WE0312M		230		4.9			
WE0511H		115		14.5			
WE0518H		208		8.1			
WE0512H		230		7.3			
WE0538H		200		4.9			
WE0532H		230	3	3.3			
WE0534H		460		1.7			
WE0537H		575		1.4			
WE0511HH	1/2	115		14.5			60
WE0518HH		208	1	8.1			
WE0512HH		230		7.3			
WE0538HH		200		4.9			
WE0532HH		230	3	3.6			
WE0534HH		460		1.8			
WE0537HH		575		1.5			
WE0718H		208	1	11.0			
WE0712H		230		10.0			
WE0738H	3/4	200		6.2			
WE0732H		230	3	5.4			
WE0734H		460		2.7		3/4"	
WE0737H		575		2.2			70
WE1018H		208	1	14.0			
WE1012H		230		12.5	3500		
WE1038H		200		8.1			
WE1032H		230	3	7.0			
WE1034H		460		3.5			
WE1037H		575		2.8			
WE1518H		208	1	17.5			
WE1512H		230		15.7			
WE1538H		200		10.6			
WE1532H		230	3	9.2			
WE1534H		460		4.6			
WE1537H		575		3.7			
WE1518HH	1 1/2	208	1	17.5			80
WE1512HH		230		15.7			
WE1538HH		200		10.6			
WE1532HH		230	3	9.2			
WE1534HH		460		4.6			
WE1537HH		575		3.7			
WE2012H		230	1	18.0			
WE2038H		200		12.0			
WE2032H		230	3	11.6			
WE2034H		460		5.8			
WE2037H		575		4.7			83

PERFORMANCE RATINGS (gallons per minute)

Order No.	WE03L	WE03M	WE05H	WE07H	WE10H	WE15H	WE05HH	WE15HH	WE20H
HP	1/3	1/3	1/2	3/4	1	1 1/2	1/2	1 1/2	2
RPM	1750	1750	3500	3500	3500	3500	3500	3500	3500
5	86	-	-	-	-	-	-	-	-
10	70	63	78	-	-	-	58	-	-
15	52	50	70	90	-	-	53	-	-
20	27	35	60	83	98	123	49	90	136
25	-	-	48	76	94	117	45	87	133
30	-	-	35	67	88	110	40	83	130
35	-	-	20	57	82	103	35	80	126
40	-	-	-	45	74	95	30	77	121
45	-	-	-	35	64	86	25	74	116
50	-	-	-	25	53	77	-	70	110
55	-	-	-	-	40	67	-	66	103
60	-	-	-	-	30	56	-	63	96
65	-	-	-	-	20	45	-	58	89
70	-	-	-	-	-	35	-	55	81
75	-	-	-	-	-	25	-	51	74
80	-	-	-	-	-	-	-	47	66
90	-	-	-	-	-	-	-	37	49
100	-	-	-	-	-	-	-	28	30

DIMENSIONS

(All dimensions are in inches. Do not use for construction purposes.)

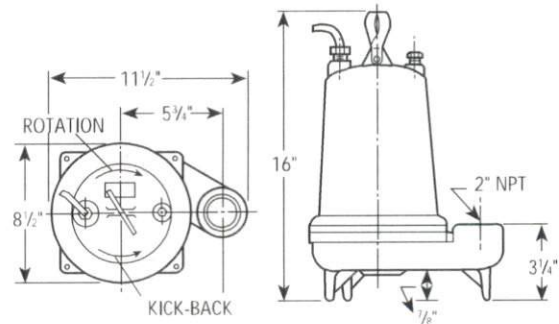

Quick4™

STANDARD CHAMBER

Quick4 Standard Chamber

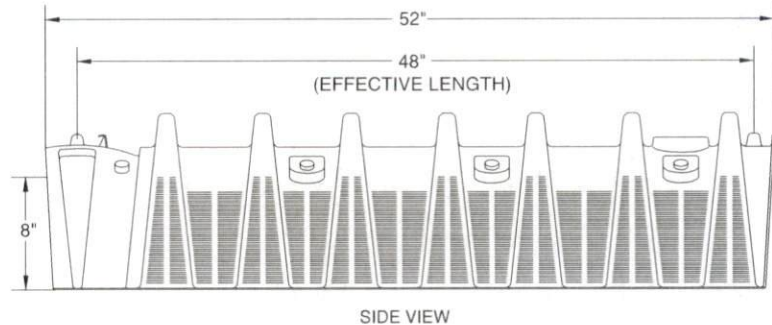
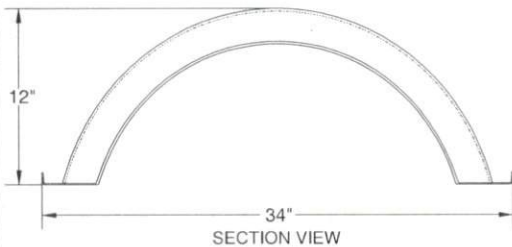

MultiPort End Cap

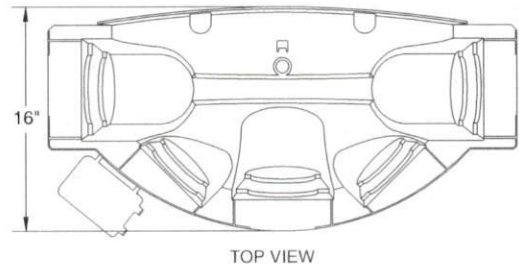
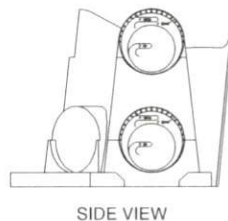
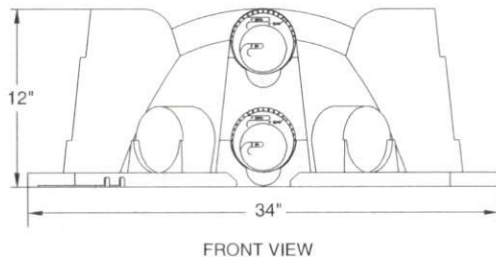

Quick4 Standard Chamber Nominal Specifications

Size (W x L x H)	34" x 52" x 12"
Effective Length	48"
Invert Height	8"

MultiPort End Cap Nominal Specifications

Size (W x L x H)	34" x 16" x 12"
Invert Height	8" or 1.25"

INFILTRATOR SYSTEMS, INC. STANDARD LIMITED WARRANTY

(a) The structural integrity of each chamber, end plate, wedge and other accessory manufactured by Infiltrator ("Units"), when installed and operated in a leachfield of an onsite septic system in accordance with Infiltrator's instructions, is warranted to the original purchaser ("Holder") against defective materials and workmanship for one year from the date that the septic permit is issued for the septic system containing the Units; provided, however, that if a septic permit is not required by applicable law, the warranty period will begin upon the date that installation of the septic system commences. To exercise its warranty rights, Holder must notify Infiltrator in writing at its Corporate Headquarters in Old Saybrook, Connecticut within fifteen (15) days of the alleged defect. Infiltrator will supply replacement Units for Units determined by Infiltrator to be covered by this Limited Warranty. Infiltrator's liability specifically excludes the cost of removal and/or installation of the Units.

(b) THE LIMITED WARRANTY AND REMEDIES IN SUBPARAGRAPH (a) ARE EXCLUSIVE. THERE ARE NO OTHER WARRANTIES WITH RESPECT TO THE UNITS, INCLUDING NO IMPLIED WARRANTIES OF MERCHANTABILITY OR FITNESS FOR A PARTICULAR PURPOSE.

(c) This Limited Warranty shall be void if any part of the chamber system is manufactured by anyone other than Infiltrator. The Limited Warranty does not extend to incidental, consequential, special or indirect damages. Infiltrator shall not be liable for penalties or liquidated damages, including loss of production and profits, labor and materials, overhead costs, or other losses or expenses incurred by the Holder or any third party. Specifically excluded from Limited Warranty coverage are damage to the Units due to ordinary wear and tear, alteration, accident, misuse, abuse or neglect of the Units; the Units being subjected to vehicle traffic or other conditions which are not permitted by the installation instructions; failure to maintain the minimum ground covers set forth in the installation instructions; the placement of improper materials into the system containing the Units; failure of the Units or the septic system due to improper siting or improper sizing, excessive water usage, improper grease disposal, or improper operation; or any other event not caused by Infiltrator. This Limited Warranty shall be void if the Holder fails to comply with all of the terms set forth in this Limited Warranty.

Further, in no event shall Infiltrator be responsible for any loss or damage to the Holder, the Units, or any third party resulting from installation or shipment, or from any product liability claims of Holder or any third party. For this Limited Warranty to apply, the Units must be installed in accordance with all site conditions required by state and local codes; all other applicable laws; and Infiltrator's installation instructions.

(d) No representative of Infiltrator has the authority to change or extend this Limited Warranty. No warranty applies to any party other than the original Holder.

The above represents the Standard Limited Warranty offered by Infiltrator. A limited number of states and counties have different warranty requirements. Any purchaser of Units should contact Infiltrator's Corporate Headquarters in Old Saybrook, Connecticut, prior to such purchase, to obtain a copy of the applicable warranty, and should carefully read that warranty prior to the purchase of Units.

INFILTRATOR®
SYSTEMS INC
Environmental Onsite Wastewater Solutions™

6 Business Park Road • P.O. Box 768
 Old Saybrook, CT 06475
 860-577-7000 • FAX 860-577-7001

800-221-4436

U.S. Patents: 4,759,661; 5,017,041; 5,156,488; 5,336,017; 5,401,116; 5,401,459; 5,511,903; 5,716,163; 5,588,778; 5,839,844
 Canadian Patents: 1,329,959; 2,004,564 Other patents pending.

Infiltrator, Equalizer and SideWinder are registered trademarks of Infiltrator Systems Inc. Infiltrator is a registered trademark in France. Infiltrator Systems Inc. is a registered trademark in Mexico. Contour, Contour Swivel Connection, MicroLeaching, PolyTuff, SnapLock, ChamberSpacer, PosiLock, QuickCut, QuickPlay and Quick4 are trademarks of Infiltrator Systems Inc. © 2003 Infiltrator Systems Inc. Printed in U.S.A.

