

RE: 22020083
 DRB GROUP - 122 FaNC

Trenco
 818 Soundside Rd
 Edenton, NC 27932

Site Information:

Customer: Project Name: 22020083
 Lot/Block: Model:
 Address: Subdivision:
 City: State:

General Truss Engineering Criteria & Design Loads (Individual Truss Design Drawings Show Special Loading Conditions):

Design Code: IRC2018/TPI2014 Design Program: MiTek 20/20 8.5
 Wind Code: ASCE 7-16 Wind Speed: 130 mph
 Roof Load: 40.0 psf Floor Load: N/A psf

This package includes 14 individual, dated Truss Design Drawings and 0 Additional Drawings.

No.	Seal#	Truss Name	Date
1	I50955705	A01	3/24/2022
2	I50955706	A02	3/24/2022
3	I50955707	A03	3/24/2022
4	I50955708	A04	3/24/2022
5	I50955709	B01	3/24/2022
6	I50955710	B02	3/24/2022
7	I50955711	C01	3/24/2022
8	I50955712	C02	3/24/2022
9	I50955713	D01	3/24/2022
10	I50955714	D02	3/24/2022
11	I50955715	F01	3/24/2022
12	I50955716	F02	3/24/2022
13	I50955717	G01	3/24/2022
14	I50955718	G02	3/24/2022

The truss drawing(s) referenced above have been prepared by Truss Engineering Co. under my direct supervision based on the parameters provided by Carter Components (Sanford, NC)).
 Truss Design Engineer's Name: Gilbert, Eric
 My license renewal date for the state of North Carolina is December 31, 2022.
 North Carolina COA: C-0844

IMPORTANT NOTE: The seal on these truss component designs is a certification that the engineer named is licensed in the jurisdiction(s) identified and that the designs comply with ANSI/TPI 1. These designs are based upon parameters shown (e.g., loads, supports, dimensions, shapes and design codes), which were given to TRENCO. Any project specific information included is for TRENCO customers file reference purpose only, and was not taken into account in the preparation of these designs. TRENCO has not independently verified the applicability of the design parameters or the designs for any particular building. Before use, the building designer should verify applicability of design parameters and properly incorporate these designs into the overall building design per ANSI/TPI 1, Chapter 2.

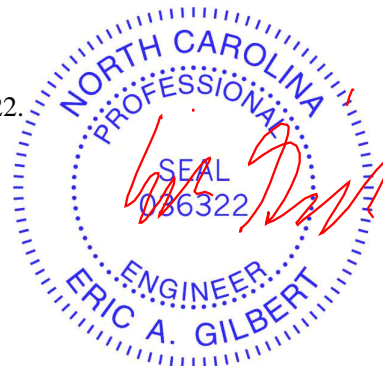

March 24, 2022

Job 22020083	Truss A01	Truss Type Common	Qty 4	Ply 1	DRB GROUP - 122 FaNC Job Reference (optional)	I50955705
-----------------	--------------	----------------------	----------	----------	--	-----------

Carter Components (Sanford), Sanford, NC - 27332,

Run: 8.53 S Dec 6 2021 Print: 8.530 S Dec 6 2021 MiTek Industries, Inc. Wed Mar 23 16:52:20
ID:bD4xs?Y6N8EeiWi69pl1?yGMN6-RfC?PsB70Hq3NSgPqnL8w3ulTXbGKwRCDoi7J4zJC?

Page: 1

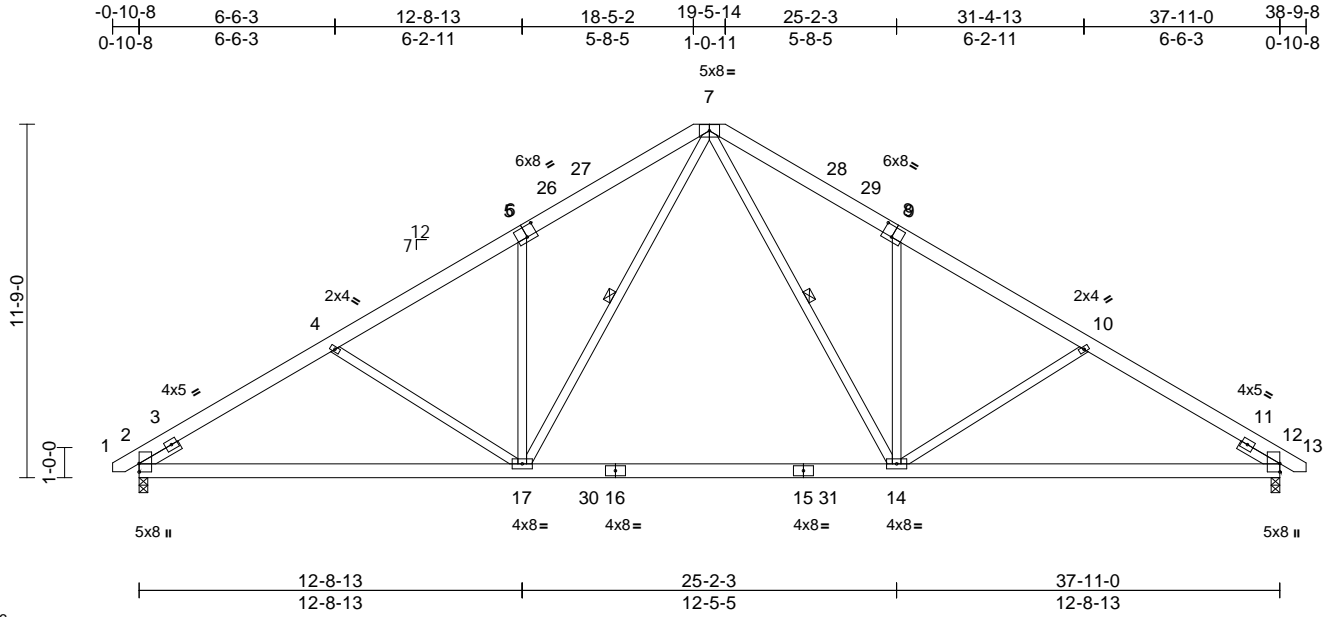

Scale = 1:76.6

Plate Offsets (X, Y): [6:0-4-0,0-4-4], [8:0-4-0,0-4-4]

Loading	(psf)	Spacing	2-0-0	CSI	DEFL	in (loc)	l/defl	L/d	PLATES	GRIP		
TCLL (roof)	20.0	Plate Grip DOL	1.15	TC	0.40	Vert(LL)	-0.31	14-17	>999	240	MT20	244/190
Snow (Pf)	20.0	Lumber DOL	1.15	BC	0.83	Vert(CT)	-0.47	14-17	>960	180		
TCDL	10.0	Rep Stress Incr	YES	WB	0.56	Horz(CT)	0.07	12	n/a	n/a		
BCLL	0.0*	Code	IRC2018/TPI2014	Matrix-MSH								
BCDL	10.0										Weight: 282 lb	FT = 20%

LUMBER
TOP CHORD 2x6 SP No.2
BOT CHORD 2x6 SP No.2
WEBS 2x4 SP No.3 *Except* 17-7,14-7:2x4 SP No.2
SLIDER Left 2x4 SP No.3 -- 1-6-0, Right 2x4 SP No.3 -- 1-6-0

BRACING
TOP CHORD Structural wood sheathing directly applied or 4-1-11 oc purlins.
BOT CHORD Rigid ceiling directly applied or 10-0-0 oc bracing.
WEBS 1 Row at midpt 7-17, 7-14

REACTIONS (lb/size) 2=1557/0-3-8, 12=1557/0-3-8
Max Horiz 2=-265 (LC 12)
Max Uplift 2=-151 (LC 14), 12=-151 (LC 15)
Max Grav 2=1783 (LC 24), 12=1783 (LC 25)

FORCES (lb) - Maximum Compression/Maximum Tension
TOP CHORD 1-2=0/20, 2-4=-2588/259, 4-5=-2321/228, 5-7=-2355/367, 7-9=-2354/367, 9-10=-2321/228, 10-12=-2589/259, 12-13=0/20
BOT CHORD 2-17=-297/2334, 14-17=-16/1512, 12-14=-130/2136
WEBS 5-17=-477/249, 7-17=-236/1197, 4-17=-296/201, 7-14=-236/1197, 9-14=-477/248, 10-14=-297/202

NOTES
1) Unbalanced roof live loads have been considered for this design.

- Wind: ASCE 7-16; Vult=130mph (3-second gust) Vasd=103mph; TCDL=6.0psf; BCDL=6.0psf; h=25ft; Cat. II; Exp B; Enclosed; MWFRS (envelope) exterior zone and C-C Exterior(2E) -0-8-1 to 3-1-7, Interior (1) 3-1-7 to 15-2-0, Exterior(2R) 15-2-0 to 22-9-0, Interior (1) 22-9-0 to 34-9-9, Exterior(2E) 34-9-9 to 38-7-1 zone; cantilever left and right exposed; end vertical left and right exposed; C-C for members and forces & MWFRS for reactions shown; Lumber DOL=1.60 plate grip DOL=1.60
- TCLL: ASCE 7-16; Pr=20.0 psf (roof LL: Lum DOL=1.15 Plate DOL=1.15); Pf=20.0 psf (Lum DOL=1.15 Plate DOL=1.15); Is=1.0; Rough Cat B; Fully Exp.; Ce=0.9; Cs=1.00; Ct=1.10
- Unbalanced snow loads have been considered for this design.
- This truss has been designed for greater of min roof live load of 12.0 psf or 1.00 times flat roof load of 20.0 psf on overhangs non-concurrent with other live loads.
- This truss has been designed for a 10.0 psf bottom chord live load nonconcurrent with any other live loads.
- * This truss has been designed for a live load of 20.0psf on the bottom chord in all areas where a rectangle 3-06-00 tall by 2-00-00 wide will fit between the bottom chord and any other members, with BCDL = 10.0psf.
- One H2.5A Simpson Strong-Tie connectors recommended to connect truss to bearing walls due to UPLIFT at jt(s) 2 and 12. This connection is for uplift only and does not consider lateral forces.
- This truss is designed in accordance with the 2018 International Residential Code sections R502.11.1 and R802.10.2 and referenced standard ANSI/TPI 1.

LOAD CASE(S) Standard

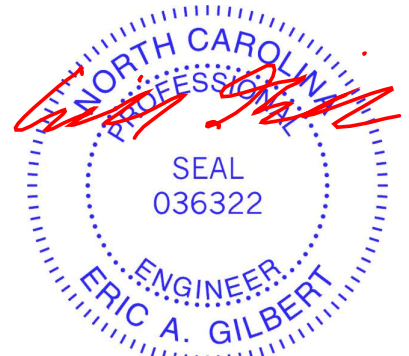

March 24, 2022

WARNING - Verify design parameters and READ NOTES ON THIS AND INCLUDED MITEK REFERENCE PAGE MII-7473 rev. 5/19/2020 BEFORE USE.

Design valid for use only with MiTek® connectors. This design is based only upon parameters shown, and is for an individual building component, not a truss system. Before use, the building designer must verify the applicability of design parameters and properly incorporate this design into the overall building design. Bracing indicated is to prevent buckling of individual truss web and/or chord members only. Additional temporary and permanent bracing is always required for stability and to prevent collapse with possible personal injury and property damage. For general guidance regarding the fabrication, storage, delivery, erection and bracing of trusses and truss systems, see

ANSI/TPI1 Quality Criteria, DSB-89 and BCSI Building Component

Safety Information available from Truss Plate Institute, 2670 Crain Highway, Suite 203 Waldorf, MD 20601



818 Soundside Road
Edenton, NC 27932

Job 22020083	Truss A02	Truss Type Common	Qty 6	Ply 1	DRB GROUP - 122 FaNC Job Reference (optional)	I50955706
-----------------	--------------	----------------------	----------	----------	--	-----------

Carter Components (Sanford), Sanford, NC - 27332,

Run: 8.53 S Dec 6 2021 Print: 8.530 S Dec 6 2021 MiTek Industries, Inc. Wed Mar 23 16:52:22
ID:bD4xs?Y6N8EeiW69pl1?yGMN6-RfC?PsB70Hq3NSgPqnl8w3ulTXbGKwRcDoi7J4zJC?f

Page: 1

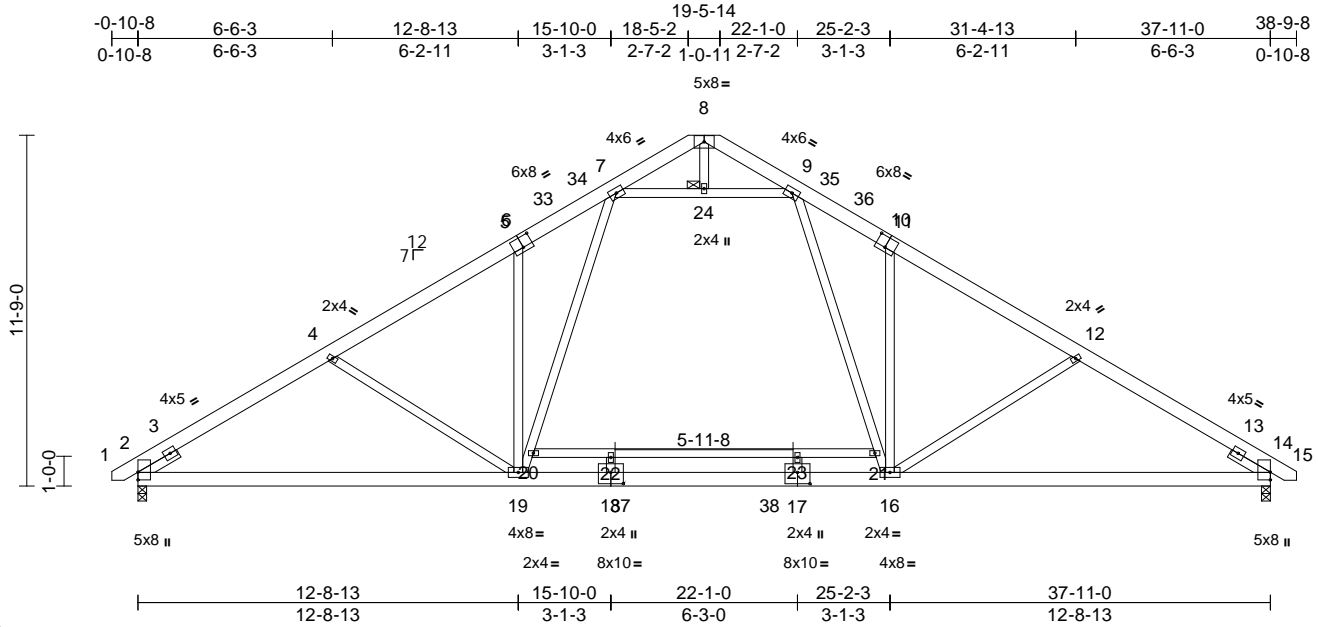

Scale = 1:77.2

Plate Offsets (X, Y): [6:0-4-0,0-4-4], [10:0-4-0,0-4-4], [17:0-5-0,0-4-8], [18:0-5-0,0-4-8]

Loading	(psf)	Spacing	2-0-0	CSI	DEFL	in	(loc)	l/defl	L/d	PLATES	GRIP	
TCLL (roof)	20.0	Plate Grip DOL	1.15	TC	0.51	Vert(LL)	-0.21	19-27	>999	240	MT20	244/190
Snow (Pf)	20.0	Lumber DOL	1.15	BC	0.78	Vert(CT)	-0.45	17-18	>999	180		
TCDL	10.0	Rep Stress Incr	YES	WB	0.63	Horz(CT)	0.08	14	n/a	n/a		
BCLL	0.0*	Code	IRC2018/TPI2014	Matrix-MSH								
BCDL	10.0											
											Weight: 303 lb	FT = 20%

LUMBER
TOP CHORD 2x6 SP No.2
BOT CHORD 2x6 SP No.2
WEBS 2x4 SP No.3 *Except* 20-21:2x4 SP No.2
SLIDER Left 2x4 SP No.3 -- 1-6-0, Right 2x4 SP No.3 -- 1-6-0

BRACING
TOP CHORD Structural wood sheathing directly applied or 3-10-3 oc purlins.
BOT CHORD Rigid ceiling directly applied or 10-0-0 oc bracing.
JOINTS 1 Brace at Jt(s): 24

REACTIONS (lb/size) 2=1658/0-3-8, 14=1655/0-3-8
Max Horiz 2=-265 (LC 12)
Max Uplift 2=-50 (LC 14), 14=-53 (LC 15)

FORCES (lb) - Maximum Compression/Maximum Tension
TOP CHORD 1-2=0/20, 2-4=-2495/62, 4-5=-2200/20, 5-7=-2238/155, 7-8=-480/113, 8-9=-483/111, 9-11=-2227/164, 11-12=-2194/26, 12-14=-2490/68, 14-15=0/20
BOT CHORD 2-19=-177/2063, 16-19=0/1501, 14-16=-23/2051
WEBS 5-19=-538/282, 19-20=-150/1044, 7-20=-134/1052, 4-19=-293/238, 9-21=-151/1034, 16-21=-165/1028, 11-16=-530/288, 12-16=-295/238, 20-22=-3/73, 22-23=-3/73, 21-23=-3/73, 18-22=0/36, 17-23=0/33, 7-24=-1230/77, 9-24=-1230/77, 8-24=-11/182

NOTES
1) Unbalanced roof live loads have been considered for this design.

- Wind: ASCE 7-16; Vult=130mph (3-second gust) Vasd=103mph; TCDL=6.0psf; BCDL=6.0psf; h=25ft; Cat. II; Exp B; Enclosed; MWFRS (envelope) exterior zone and C-C Exterior(2E) -0-8-1 to 3-1-7, Interior (1) 3-1-7 to 15-2-0, Exterior(2R) 15-2-0 to 22-9-0, Interior (1) 22-9-0 to 34-9-9, Exterior(2E) 34-9-9 to 38-7-1 zone; cantilever left and right exposed; end vertical left and right exposed; C-C for members and forces & MWFRS for reactions shown; Lumber DOL=1.60 plate grip DOL=1.60
- TCLL: ASCE 7-16; Pr=20.0 psf (roof LL: Lum DOL=1.15 Plate DOL=1.15); Pf=20.0 psf (Lum DOL=1.15 Plate DOL=1.15); Is=1.0; Rough Cat B; Fully Exp.; Ce=0.9; Cs=1.00; Ct=1.10
- Unbalanced snow loads have been considered for this design.
- This truss has been designed for greater of min roof live load of 12.0 psf or 1.00 times flat roof load of 20.0 psf on overhangs non-concurrent with other live loads.
- 200.0lb AC unit load placed on the bottom chord, 18-8-0 from left end, supported at two points, 5-0-0 apart.
- This truss has been designed for a 10.0 psf bottom chord live load nonconcurrent with any other live loads.
- * This truss has been designed for a live load of 20.0psf on the bottom chord in all areas where a rectangle 3-06-00 tall by 2-00-00 wide will fit between the bottom chord and any other members.
- One H2.5A Simpson Strong-Tie connectors recommended to connect truss to bearing walls due to UPLIFT at jt(s) 2 and 14. This connection is for uplift only and does not consider lateral forces.
- This truss is designed in accordance with the 2018 International Residential Code sections R502.11.1 and R802.10.2 and referenced standard ANSI/TPI 1.

LOAD CASE(S) Standard

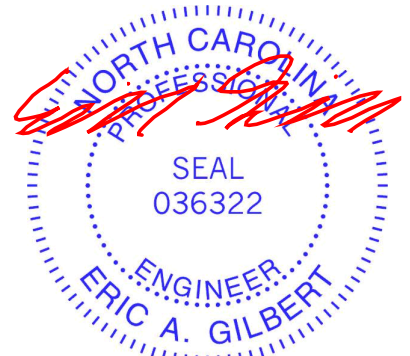

March 24, 2022

WARNING - Verify design parameters and READ NOTES ON THIS AND INCLUDED MITEK REFERENCE PAGE MII-7473 rev. 5/19/2020 BEFORE USE.

Design valid for use only with MiTek® connectors. This design is based only upon parameters shown, and is for an individual building component, not a truss system. Before use, the building designer must verify the applicability of design parameters and properly incorporate this design into the overall building design. Bracing indicated is to prevent buckling of individual truss web and/or chord members only. Additional temporary and permanent bracing is always required for stability and to prevent collapse with possible personal injury and property damage. For general guidance regarding the fabrication, storage, delivery, erection and bracing of trusses and truss systems, see ANSITPI Quality Criteria, DSB-89 and BCSI Building Component Safety Information available from Truss Plate Institute, 2670 Crain Highway, Suite 203 Waldorf, MD 20601



818 Soundside Road
Edenton, NC 27932

Job 22020083	Truss A03	Truss Type Common Structural Gable	Qty 1	Ply 1	DRB GROUP - 122 FaNC Job Reference (optional)	I50955707
-----------------	--------------	---------------------------------------	----------	----------	--	-----------

Carter Components (Sanford), Sanford, NC - 27332,

Run: 8.53 S Dec 6 2021 Print: 8.530 S Dec 6 2021 MiTek Industries, Inc. Wed Mar 23 16:52:23
ID:9knqKob6Z3XfTU7aZooqfMLyGMKT-RfC?PsB70Hq3NSgPqnL8w3lTXbGKwRCoI7J4zJC?f

Page: 1

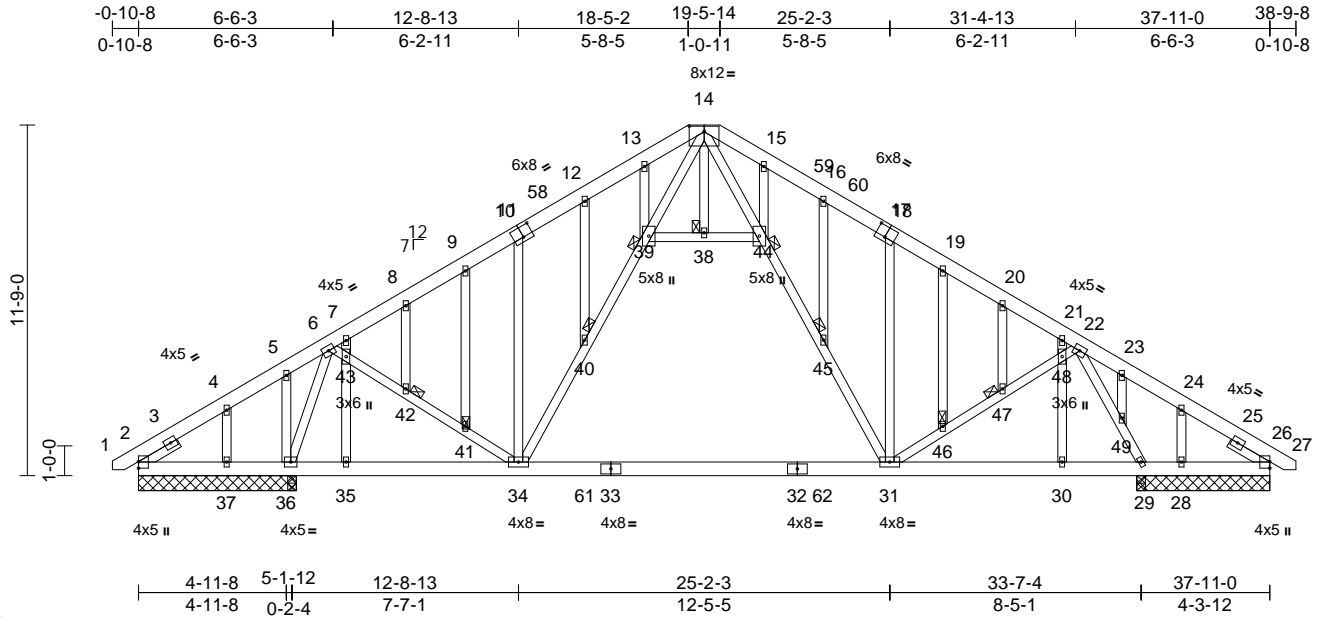

Scale = 1:77.2

Plate Offsets (X, Y): [11:0-4-0,0-4-4], [14:0-6-0,0-2-4], [17:0-4-0,0-4-4]

Loading	(psf)	Spacing	2-0-0	CSI	DEFL	in (loc)	l/defl	L/d	PLATES	GRIP		
TCLL (roof)	20.0	Plate Grip DOL	1.15	TC	0.21	Vert(LL)	-0.26	31-34	>999	240	MT20	244/190
Snow (Pf)	20.0	Lumber DOL	1.15	BC	0.70	Vert(CT)	-0.40	31-34	>863	180		
TCDL	10.0	Rep Stress Incr	YES	WB	0.59	Horz(CT)	0.02	29	n/a	n/a		
BCLL	0.0*	Code	IRC2018/TPI2014	Matrix-MSH								
BCDL	10.0											
											Weight: 376 lb	FT = 20%

LUMBER	TOP CHORD	BOT CHORD	WEBS	OTHERS	SLIDER	BRACING	TOP CHORD	BOT CHORD	WEBS	REACTIONS	FORCES	NOTES
TOP CHORD 2x6 SP No.2	1-2=0/20, 2-4=-138/261, 4-5=-94/238, 5-6=-89/203, 6-7=-1166/103, 7-8=-1196/123, 8-9=-1149/140, 9-10=-1087/155, 10-12=-1187/239, 12-13=-1141/256, 13-14=-1141/311, 14-15=-1206/323, 15-16=-1255/290, 16-18=-1291/271, 18-19=-1160/160, 19-20=-1216/146, 20-21=-1258/129, 21-22=-1258/109, 22-23=0/207, 23-24=0/118, 24-26=-53/207, 26-27=0/20	2-37=-189/149, 36-37=-189/149, 35-36=-94/383, 34-35=-94/383, 31-34=0/858, 30-31=0/510, 29-30=0/510, 28-29=-134/87, 26-28=-134/87	10-34=-438/209, 34-40=-126/450, 39-40=-137/486, 14-39=-204/586, 6-43=0/812, 42-43=0/833, 41-42=0/822, 34-41=0/844, 14-44=-215/652, 44-45=-163/633, 31-45=-150/590, 18-31=-410/205, 31-46=0/638, 46-47=0/626, 47-48=0/634, 22-48=0/612, 14-38=-12/27, 13-39=-170/89, 12-40=-41/13, 9-41=0/42, 8-42=-27/17, 7-43=-108/22, 35-43=-161/48, 5-36=-145/1, 4-37=-144/112, 15-44=-89/66, 16-45=-49/15, 19-46=0/30, 20-47=-27/17, 21-48=-34/27, 30-48=-89/41, 23-49=-15/114, 24-28=-281/110, 6-36=-1235/143, 22-49=-1426/127, 29-49=-1324/113, 38-39=-94/46, 38-44=-92/45	1 Brace at Jt(s): 38, 39, 40, 41, 42, 44, 45, 46, 47	Left 2x4 SP No.3 -- 1-6-0, Right 2x4 SP No.3 -- 1-6-0	TOP CHORD Structural wood sheathing directly applied or 6-0-0 oc purlins. BOT CHORD Rigid ceiling directly applied or 6-0-0 oc bracing. JOINTS 1 Brace at Jt(s): 38, 39, 40, 41, 42, 44, 45, 46, 47	2=113/5-3-8, 26=76/4-5-8, 28=145/4-5-8, 29=1302/0-3-8, 36=1393/5-3-8, 37=85/5-3-8, 50=113/5-3-8, 54=76/4-5-8 Max Horiz 2=266 (LC 13), 50=266 (LC 13) Max Uplift 2=-63 (LC 10), 28=-88 (LC 15), 29=-99 (LC 15), 36=-150 (LC 14), 37=-88 (LC 14), 50=-63 (LC 10) Max Grav 2=142 (LC 25), 26=83 (LC 35), 28=182 (LC 29), 29=1539 (LC 25), 36=1670 (LC 24), 37=143 (LC 24), 50=142 (LC 25), 54=83 (LC 35)	(lb) - Maximum Compression/Maximum Tension	1) Unbalanced roof live loads have been considered for this design.			



Continued on page 2

WARNING - Verify design parameters and READ NOTES ON THIS AND INCLUDED MITEK REFERENCE PAGE MII-7473 rev. 5/19/2020 BEFORE USE.

Design valid for use only with MiTek® connectors. This design is based only upon parameters shown, and is for an individual building component, not a truss system. Before use, the building designer must verify the applicability of design parameters and properly incorporate this design into the overall building design. Bracing indicated is to prevent buckling of individual truss web and/or chord members only. Additional temporary and permanent bracing is always required for stability and to prevent collapse with possible personal injury and property damage. For general guidance regarding the fabrication, storage, delivery, erection and bracing of trusses and truss systems, see **ANSI/TPI Quality Criteria, DSB-89 and BCSI Building Component Safety Information** available from Truss Plate Institute, 2670 Crain Highway, Suite 203 Waldorf, MD 20601



818 Soundside Road
Edenton, NC 27932

Job 22020083	Truss A03	Truss Type Common Structural Gable	Qty 1	Ply 1	DRB GROUP - 122 FaNC Job Reference (optional)	I50955707
-----------------	--------------	---------------------------------------	----------	----------	--	-----------

Carter Components (Sanford), Sanford, NC - 27332,

Run: 8.53 S Dec 6 2021 Print: 8.530 S Dec 6 2021 MiTek Industries, Inc. Wed Mar 23 16:52:23
ID:9knqKob6Z3XfTU7aZoqfMLyGMKT-RfC?PsB70Hq3NSgPqnL8w3uITXbGKWrCDoi7J4zJC?f

Page: 2

- 6) This truss has been designed for greater of min roof live load of 12.0 psf or 1.00 times flat roof load of 20.0 psf on overhangs non-concurrent with other live loads.
- 7) All plates are 2x4 MT20 unless otherwise indicated.
- 8) Gable studs spaced at 2-0-0 oc.
- 9) This truss has been designed for a 10.0 psf bottom chord live load nonconcurrent with any other live loads.
- 10) * This truss has been designed for a live load of 20.0psf on the bottom chord in all areas where a rectangle 3-06-00 tall by 2-00-00 wide will fit between the bottom chord and any other members, with BCDL = 10.0psf.

WARNING - Verify design parameters and READ NOTES ON THIS AND INCLUDED MITEK REFERENCE PAGE MII-7473 rev. 5/19/2020 BEFORE USE.

Design valid for use only with MiTek® connectors. This design is based only upon parameters shown, and is for an individual building component, not a truss system. Before use, the building designer must verify the applicability of design parameters and properly incorporate this design into the overall building design. Bracing indicated is to prevent buckling of individual truss web and/or chord members only. Additional temporary and permanent bracing is always required for stability and to prevent collapse with possible personal injury and property damage. For general guidance regarding the fabrication, storage, delivery, erection and bracing of trusses and truss systems, see **ANSI/TPI1 Quality Criteria, DSB-89 and BCSI Building Component Safety Information** available from Truss Plate Institute, 2670 Crain Highway, Suite 203 Waldorf, MD 20601



818 Soundside Road
Edenton, NC 27932

Job 22020083	Truss A04	Truss Type Common Supported Gable	Qty 1	Ply 1	DRB GROUP - 122 FaNC Job Reference (optional)	I50955708
-----------------	--------------	--------------------------------------	----------	----------	--	-----------

Carter Components (Sanford), Sanford, NC - 27332,

Run: 8.53 S Dec 6 2021 Print: 8.530 S Dec 6 2021 MiTek Industries, Inc. Wed Mar 23 16:52:25
ID:hussyWcpnt6lYOYkURLML2yGMJ9-RfC?PsB70Hq3NSgPqnL8w3uTXbGKWrCDoi7J4zJC?f

Page: 1

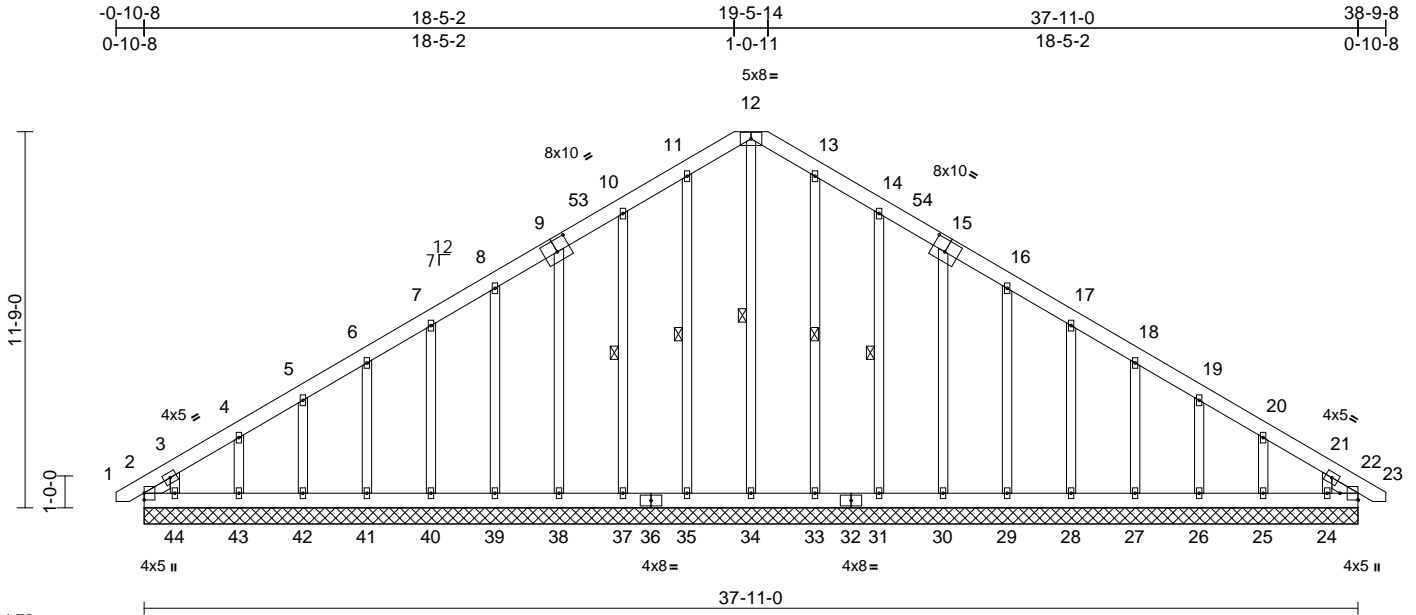

Scale = 1:72

Plate Offsets (X, Y): [9:0-5-0,0-4-8], [15:0-5-0,0-4-8], [22:Edge,0-6-12]

Loading	(psf)	Spacing	1-11-4	CSI	DEFL	in	(loc)	l/defl	L/d	PLATES	GRIP	
TCLL (roof)	20.0	Plate Grip DOL	1.15	TC	0.05	Vert(LL)	n/a	-	n/a	999	MT20	244/190
Snow (Pf)	20.0	Lumber DOL	1.15	BC	0.03	Vert(CT)	n/a	-	n/a	999		
TCDL	10.0	Rep Stress Incr	YES	WB	0.15	Horz(CT)	0.01	22	n/a	n/a		
BCLL	0.0*	Code	IRC2018/TPI2014	Matrix-MSH								
BCDL	10.0											
											Weight: 358 lb	FT = 20%

LUMBER		Max Grav	WEBS
TOP CHORD	2x6 SP No.2	2=233 (LC 14), 22=172 (LC 15), 24=154 (LC 25), 25=165 (LC 25), 26=161 (LC 25), 27=161 (LC 25), 28=162 (LC 25), 29=154 (LC 25), 30=164 (LC 22), 31=228 (LC 22), 33=232 (LC 22), 34=191 (LC 27), 35=232 (LC 21), 37=228 (LC 21), 38=164 (LC 21), 39=154 (LC 24), 40=162 (LC 24), 41=161 (LC 24), 42=161 (LC 24), 43=165 (LC 24), 44=186 (LC 24), 45=233 (LC 14), 49=172 (LC 15)	12-34=161/47, 11-35=193/47, 10-37=189/83, 9-38=125/73, 8-39=115/67, 7-40=123/73, 6-41=123/72, 5-42=122/71, 4-43=128/78, 3-44=114/129, 13-33=193/39, 14-31=189/86, 15-30=125/74, 16-29=115/66, 17-28=123/73, 18-27=123/72, 19-26=122/71, 20-25=127/77, 21-24=92/109
BOT CHORD	2x6 SP No.2		
OTHERS	2x4 SP No.3 *Except* 34-12:2x4 SP No.2		
SLIDER	Left 2x4 SP No.3 -- 0-11-6, Right 2x4 SP No.3 -- 0-11-6		

BRACING		FORCES
TOP CHORD	Structural wood sheathing directly applied or 6-0-0 oc purlins.	(lb) - Maximum Compression/Maximum Tension
BOT CHORD	Rigid ceiling directly applied or 10-0-0 oc bracing.	
WEBS	1 Row at midpt 12-34, 11-35, 10-37, 13-33, 14-31	

REACTIONS	(lb/size)	TOP CHORD	BOT CHORD
Max Horiz	2=-260 (LC 12), 45=-260 (LC 12)	1-2=0/20, 2-3=-182/142, 3-4=-222/186, 4-5=-187/167, 5-6=-163/150, 6-7=-149/139, 7-8=-136/140, 8-10=-122/193, 10-11=-135/225, 11-12=-149/245, 12-13=-149/245, 13-14=-135/216, 14-16=-105/165, 16-17=-62/78, 17-18=-72/49, 18-19=-82/55, 19-20=-108/72, 20-21=-158/91, 21-22=-138/77, 22-23=0/20	2-44=88/183, 43-44=88/183, 42-43=88/183, 41-42=88/183, 40-41=88/183, 39-40=88/183, 38-39=88/183, 37-38=88/184, 35-37=88/184, 34-35=88/184, 33-34=88/184, 31-33=88/184, 30-31=88/184, 29-30=86/182, 28-29=86/182, 27-28=86/182, 26-27=86/182, 25-26=86/182, 24-25=86/182, 22-24=86/182
Max Uplift	2=-149 (LC 12), 22=-58 (LC 13), 24=-132 (LC 15), 25=-50 (LC 15), 26=-49 (LC 15), 27=-49 (LC 15), 28=-49 (LC 15), 29=-43 (LC 15), 30=-50 (LC 15), 31=-63 (LC 15), 33=-15 (LC 15), 35=-24 (LC 14), 37=-60 (LC 14), 38=-50 (LC 14), 39=-43 (LC 14), 40=-49 (LC 14), 41=-49 (LC 14), 42=-49 (LC 14), 43=-50 (LC 14), 44=-161 (LC 14), 45=-149 (LC 12), 49=-58 (LC 13)		



March 24, 2022

Continued on page 2

WARNING - Verify design parameters and READ NOTES ON THIS AND INCLUDED MITEK REFERENCE PAGE MII-7473 rev. 5/19/2020 BEFORE USE.

Design valid for use only with MiTek® connectors. This design is based only upon parameters shown, and is for an individual building component, not a truss system. Before use, the building designer must verify the applicability of design parameters and properly incorporate this design into the overall building design. Bracing indicated is to prevent buckling of individual truss web and/or chord members only. Additional temporary and permanent bracing is always required for stability and to prevent collapse with possible personal injury and property damage. For general guidance regarding the fabrication, storage, delivery, erection and bracing of trusses and truss systems, see **ANSI/TPI1 Quality Criteria, DSB-89 and BCSI Building Component Safety Information** available from Truss Plate Institute, 2670 Crain Highway, Suite 203 Waldorf, MD 20601



818 Soundside Road
Edenton, NC 27932

Job	Truss	Truss Type	Qty	Ply	DRB GROUP - 122 FaNC	I50955708
22020083	A04	Common Supported Gable	1	1	Job Reference (optional)	

Carter Components (Sanford), Sanford, NC - 27332,

Run: 8.53 S Dec 6 2021 Print: 8.530 S Dec 6 2021 MiTek Industries, Inc. Wed Mar 23 16:52:25
ID:husayWcpnt6lYOYkURLMl2yGMJ9-RfC?PsB70Hq3NSgPqnL8w3ulTXbGKWrCDoi7J4zJC?f

Page: 2

- 2) Wind: ASCE 7-16; Vult=130mph (3-second gust)
Vasd=103mph; TCDL=6.0psf; BCDL=6.0psf; h=25ft;
Cat. II; Exp B; Enclosed; MWFRS (envelope) exterior
zone and C-C Corner(3E) -0-8-1 to 2-11-8, Exterior(2N)
2-11-8 to 14-11-8, Corner(3R) 14-11-8 to 22-11-8,
Exterior(2N) 22-11-8 to 34-9-9, Corner(3E) 34-9-9 to
38-7-1 zone; cantilever left and right exposed ; end
vertical left and right exposed;C-C for members and
forces & MWFRS for reactions shown; Lumber
DOL=1.60 plate grip DOL=1.60
- 3) Truss designed for wind loads in the plane of the truss
only. For studs exposed to wind (normal to the face),
see Standard Industry Gable End Details as applicable,
or consult qualified building designer as per ANSI/TPI 1.
- 4) TCELL: ASCE 7-16; Pr=20.0 psf (roof LL: Lum DOL=1.15
Plate DOL=1.15); Pf=20.0 psf (Lum DOL=1.15 Plate
DOL=1.15); Is=1.0; Rough Cat B; Fully Exp.; Ce=0.9;
Cs=1.00; Ct=1.10
- 5) Unbalanced snow loads have been considered for this
design.
- 6) This truss has been designed for greater of min roof live
load of 12.0 psf or 1.00 times flat roof load of 20.0 psf on
overhangs non-concurrent with other live loads.
- 7) All plates are 2x4 MT20 unless otherwise indicated.
- 8) Gable requires continuous bottom chord bearing.
- 9) Gable studs spaced at 2-0-0 oc.
- 10) This truss has been designed for a 10.0 psf bottom
chord live load nonconcurrent with any other live loads.
- 11) * This truss has been designed for a live load of 20.0psf
on the bottom chord in all areas where a rectangle
3-06-00 tall by 2-00-00 wide will fit between the bottom
chord and any other members.

WARNING - Verify design parameters and READ NOTES ON THIS AND INCLUDED MITEK REFERENCE PAGE MII-7473 rev. 5/19/2020 BEFORE USE.

Design valid for use only with MiTek® connectors. This design is based only upon parameters shown, and is for an individual building component, not a truss system. Before use, the building designer must verify the applicability of design parameters and properly incorporate this design into the overall building design. Bracing indicated is to prevent buckling of individual truss web and/or chord members only. Additional temporary and permanent bracing is always required for stability and to prevent collapse with possible personal injury and property damage. For general guidance regarding the fabrication, storage, delivery, erection and bracing of trusses and truss systems, see **ANSI/TPI1 Quality Criteria, DSB-89 and BCSI Building Component Safety Information** available from Truss Plate Institute, 2670 Crain Highway, Suite 203 Waldorf, MD 20601



818 Soundside Road
Edenton, NC 27932

Job 22020083	Truss B01	Truss Type Common	Qty 3	Ply 1	DRB GROUP - 122 FaNC Job Reference (optional)	150955709
-----------------	--------------	----------------------	----------	----------	--	-----------

Carter Components (Sanford), Sanford, NC - 27332,

Run: 8.53 S Dec 6 2021 Print: 8.530 S Dec 6 2021 MiTek Industries, Inc. Wed Mar 23 16:52:26
ID:tZ4bPv91BhnMSJUNOev4YyGMIS-RfC?PsB70Hq3NSgPqnL8w3uITXbGKWRcD0j74zJC?f

Page: 1

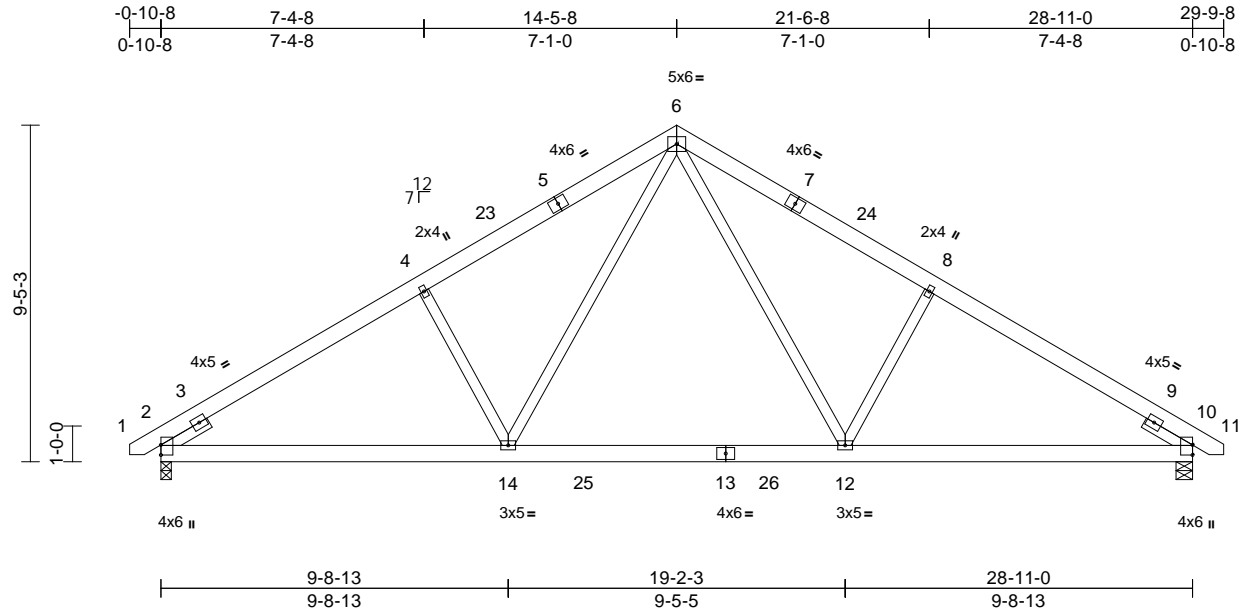

Loading	(psf)	Spacing	2-0-0	CSI	DEFL	in	(loc)	l/defl	L/d	PLATES	GRIP
TCLL (roof)	20.0	Plate Grip DOL	1.15	TC	0.47	Vert(LL)	-0.13	12-14	>999	240	244/190
Snow (Pf)	20.0	Lumber DOL	1.15	BC	0.52	Vert(CT)	-0.20	12-14	>999	180	
TCDL	10.0	Rep Stress Incr	YES	WB	0.31	Horz(CT)	0.04	10	n/a	n/a	
BCLL	0.0*	Code	IRC2018/TPI2014	Matrix-MSH							
BCDL	10.0										
										Weight: 199 lb	FT = 20%

LUMBER	
TOP CHORD	2x6 SP No.2
BOT CHORD	2x6 SP No.2
WEBS	2x4 SP No.3
SLIDER	Left 2x4 SP No.3 -- 1-6-0, Right 2x4 SP No.3 -- 1-6-0
BRACING	
TOP CHORD	Structural wood sheathing directly applied or 5-1-3 oc purlins.
BOT CHORD	Rigid ceiling directly applied or 10-0-0 oc bracing.
REACTIONS	(lb/size)
	2=1197/0-3-8, 10=1197/0-5-8
	Max Horiz 2=-207 (LC 12)
	Max Uplift 2=-117 (LC 14), 10=-117 (LC 15)
	Max Grav 2=1361 (LC 24), 10=1361 (LC 25)
FORCES	(lb) - Maximum Compression/Maximum Tension
TOP CHORD	1-2=0/20, 2-4=-1868/190, 4-6=-1727/242, 6-8=-1727/242, 8-10=-1868/190, 10-11=0/20
BOT CHORD	2-14=-205/1674, 12-14=-14/1126, 10-12=-83/1520
WEBS	6-12=-126/799, 8-12=-427/249, 6-14=-126/798, 4-14=-427/249

- TCLL: ASCE 7-16; Pr=20.0 psf (roof LL: Lum DOL=1.15 Plate DOL=1.15); Pf=20.0 psf (Lum DOL=1.15 Plate DOL=1.15); Is=1.0; Rough Cat B; Fully Exp.; Ce=0.9; Cs=1.00; Ct=1.10
- Unbalanced snow loads have been considered for this design.
- This truss has been designed for greater of min roof live load of 12.0 psf or 1.00 times flat roof load of 20.0 psf on overhangs non-concurrent with other live loads.
- This truss has been designed for a 10.0 psf bottom chord live load nonconcurrent with any other live loads.
- * This truss has been designed for a live load of 20.0psf on the bottom chord in all areas where a rectangle 3-06-00 tall by 2-00-00 wide will fit between the bottom chord and any other members, with BCDL = 10.0psf.
- One H2.5A Simpson Strong-Tie connectors recommended to connect truss to bearing walls due to UPLIFT at jt(s) 2 and 10. This connection is for uplift only and does not consider lateral forces.
- This truss is designed in accordance with the 2018 International Residential Code sections R502.11.1 and R802.10.2 and referenced standard ANSI/TPI 1.

LOAD CASE(S) Standard

NOTES

- Unbalanced roof live loads have been considered for this design.
- Wind: ASCE 7-16; Vult=130mph (3-second gust) Vasd=103mph; TCDL=6.0psf; BCDL=6.0psf; h=25ft; Cat. II; Exp B; Enclosed; MWFRS (envelope) exterior zone and C-C Exterior(2E) -0-8-1 to 2-8-11, Interior (1) 2-8-11 to 11-0-13, Exterior(2R) 11-0-13 to 17-10-3, Interior (1) 17-10-3 to 26-2-5, Exterior(2E) 26-2-5 to 29-7-1 zone; cantilever left and right exposed ; end vertical left and right exposed;C-C for members and forces & MWFRS for reactions shown; Lumber DOL=1.60 plate grip DOL=1.60

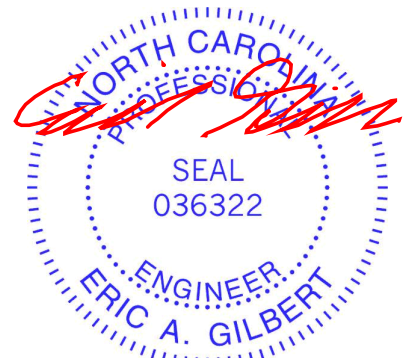

March 24, 2022

WARNING - Verify design parameters and READ NOTES ON THIS AND INCLUDED MITEK REFERENCE PAGE MII-7473 rev. 5/19/2020 BEFORE USE.

Design valid for use only with MiTek® connectors. This design is based only upon parameters shown, and is for an individual building component, not a truss system. Before use, the building designer must verify the applicability of design parameters and properly incorporate this design into the overall building design. Bracing indicated is to prevent buckling of individual truss web and/or chord members only. Additional temporary and permanent bracing is always required for stability and to prevent collapse with possible personal injury and property damage. For general guidance regarding the fabrication, storage, delivery, erection and bracing of trusses and truss systems, see **ANSI/TPI1 Quality Criteria, DSB-89 and BCSI Building Component Safety Information** available from Truss Plate Institute, 2670 Crain Highway, Suite 203 Waldorf, MD 20601



818 Soundside Road
Edenton, NC 27932

Job 22020083	Truss B02	Truss Type Common Structural Gable	Qty 1	Ply 1	DRB GROUP - 122 FaNC Job Reference (optional)	150955710
-----------------	--------------	---------------------------------------	----------	----------	--	-----------

Carter Components (Sanford), Sanford, NC - 27332,

Run: 8.53 S Dec 6 2021 Print: 8.530 S Dec 6 2021 MiTek Industries, Inc. Wed Mar 23 16:52:26
ID:NGVV_w_pqHvvlis4QS2d0dz4MyGMF_-RfC?PsB70Hq3NSgPqnL8w3uTXbGKwCRDoi7J4zJC?f

Page: 1

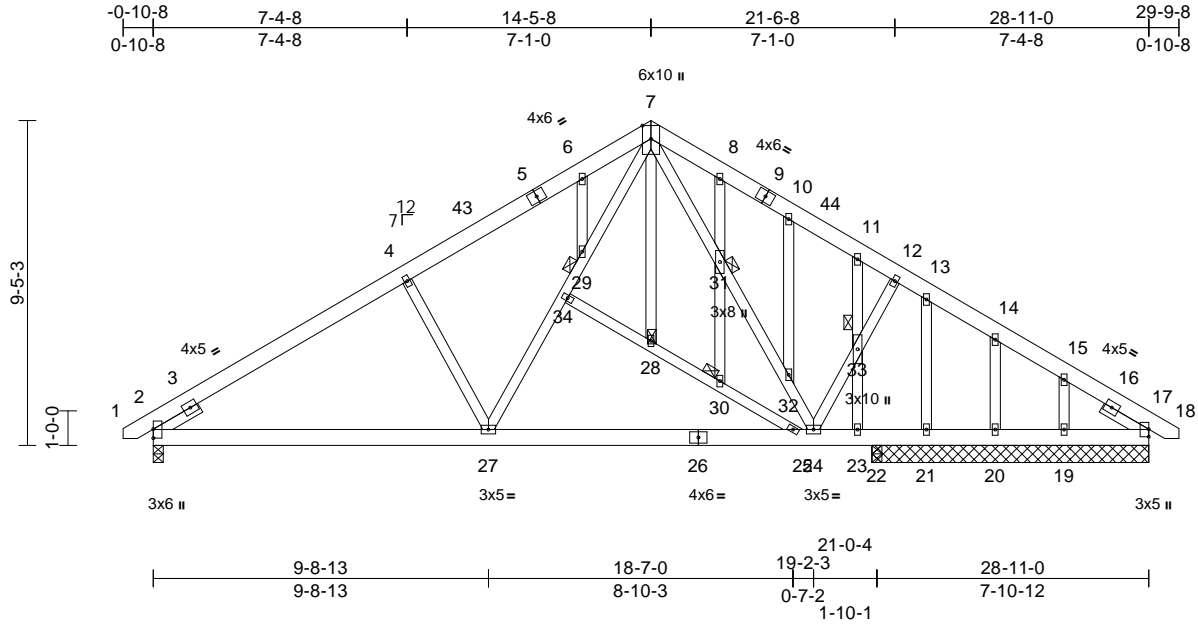

Scale = 1:66.9

Loading	(psf)	Spacing	1-11-4	CSI	DEFL	in	(loc)	l/defl	L/d	PLATES	GRIP	
TCLL (roof)	20.0	Plate Grip DOL	1.15	TC	0.19	Vert(LL)	-0.04	25-27	>999	240	MT20	244/190
Snow (Pf)	20.0	Lumber DOL	1.15	BC	0.37	Vert(CT)	-0.09	25-27	>999	180		
TCDL	10.0	Rep Stress Incr	YES	WB	0.63	Horz(CT)	0.02	39	n/a	n/a		
BCLL	0.0*	Code	IRC2018/TPI2014	Matrix-MSH								
BCDL	10.0											
											Weight: 258 lb	FT = 20%

LUMBER
TOP CHORD 2x6 SP No.2
BOT CHORD 2x6 SP No.2
WEBS 2x4 SP No.3
OTHERS 2x4 SP No.3
SLIDER Left 2x4 SP No.3 -- 1-6-0, Right 2x4 SP No.3 -- 1-6-0

BRACING
TOP CHORD Structural wood sheathing directly applied or 6-0-0 oc purlins.
BOT CHORD Rigid ceiling directly applied or 10-0-0 oc bracing.
JOINTS 1 Brace at Jt(s): 28, 29, 30, 31, 33

REACTIONS (lb/size)
2=877/0-3-8, 17=174/8-0-8, 19=166/8-0-8, 20=140/8-0-8, 21=318/8-0-8, 22=645/0-3-8, 39=174/8-0-8
Max Horiz 2=-199 (LC 12)
Max Uplift 2=-96 (LC 14), 19=-95 (LC 15), 20=-47 (LC 15), 22=-111 (LC 15)
Max Grav 2=925 (LC 21), 17=176 (LC 22), 19=191 (LC 25), 20=145 (LC 25), 21=330 (LC 7), 22=695 (LC 22), 39=176 (LC 22)

FORCES (lb) - Maximum Compression/Maximum Tension
TOP CHORD 1-2=0/20, 2-4=-1198/137, 4-6=-1030/177, 6-7=-973/238, 7-8=-364/149, 8-10=-408/129, 10-11=-451/100, 11-12=-236/58, 12-13=-266/51, 13-14=-78/40, 14-15=-109/16, 15-17=-113/24, 17-18=0/20
BOT CHORD 2-27=-188/959, 25-27=-8/546, 24-25=0/470, 23-24=-20/114, 22-23=-20/114, 21-22=-20/114, 20-21=-20/114, 19-20=-20/114, 17-19=-20/114

WEBS
7-31=-301/51, 31-32=-314/48, 24-32=-326/68, 24-33=0/602, 12-33=0/528, 27-34=-92/568, 29-34=-89/565, 7-29=-176/820, 4-27=-349/212, 7-28=-27/53, 6-29=-301/99, 8-31=-56/18, 30-31=-58/31, 10-32=-81/41, 11-33=-523/93, 23-33=-593/78, 13-21=-498/13, 14-20=-80/73, 15-19=-138/97, 28-34=-117/41, 28-30=-119/37, 25-30=-117/41

- NOTES**
- 1) Unbalanced roof live loads have been considered for this design.
 - 2) Wind: ASCE 7-16; Vult=130mph (3-second gust) Vasd=103mph; TCDL=6.0psf; BCDL=6.0psf; h=25ft; Cat. II; Exp B; Enclosed; MWFRS (envelope) exterior zone and C-C Exterior(2E) -0-8-1 to 2-8-11, Interior (1) 2-8-11 to 10-11-5, Exterior(2R) 10-11-5 to 17-8-12, Interior (1) 17-8-12 to 26-2-5, Exterior(2E) 26-2-5 to 29-7-1 zone; cantilever left and right exposed; end vertical left and right exposed; C-C for members and forces & MWFRS for reactions shown; Lumber DOL=1.60 plate grip DOL=1.60
 - 3) Truss designed for wind loads in the plane of the truss only. For studs exposed to wind (normal to the face), see Standard Industry Gable End Details as applicable, or consult qualified building designer as per ANSI/TPI 1.
 - 4) TCLL: ASCE 7-16; Pr=20.0 psf (roof LL: Lum DOL=1.15 Plate DOL=1.15); Pf=20.0 psf (Lum DOL=1.15 Plate DOL=1.15); Is=1.0; Rough Cat B; Fully Exp.; Ce=0.9; Cs=1.00; Ct=1.10
 - 5) Unbalanced snow loads have been considered for this design.
 - 6) This truss has been designed for greater of min roof live load of 12.0 psf or 1.00 times flat roof load of 20.0 psf on overhangs non-concurrent with other live loads.
 - 7) All plates are 2x4 MT20 unless otherwise indicated.
 - 8) Gable studs spaced at 2-0-0 oc.

- 9) This truss has been designed for a 10.0 psf bottom chord live load nonconcurrent with any other live loads.
- 10) * This truss has been designed for a live load of 20.0psf on the bottom chord in all areas where a rectangle 3-06-00 tall by 2-00-00 wide will fit between the bottom chord and any other members.

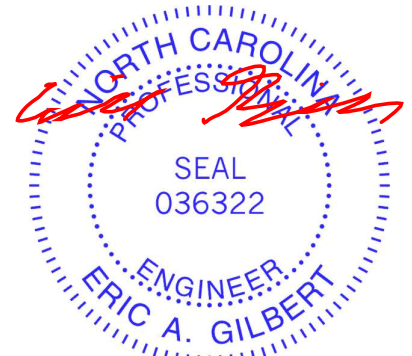

March 24, 2022

WARNING - Verify design parameters and READ NOTES ON THIS AND INCLUDED MITEK REFERENCE PAGE MII-7473 rev. 5/19/2020 BEFORE USE.

Design valid for use only with MiTek® connectors. This design is based only upon parameters shown, and is for an individual building component, not a truss system. Before use, the building designer must verify the applicability of design parameters and properly incorporate this design into the overall building design. Bracing indicated is to prevent buckling of individual truss web and/or chord members only. Additional temporary and permanent bracing is always required for stability and to prevent collapse with possible personal injury and property damage. For general guidance regarding the fabrication, storage, delivery, erection and bracing of trusses and truss systems, see ANSITPI Quality Criteria, DSB-89 and BCSI Building Component Safety Information available from Truss Plate Institute, 2670 Crain Highway, Suite 203 Waldorf, MD 20601



818 Soundside Road
Edenton, NC 27932

Job 22020083	Truss C01	Truss Type Roof Special	Qty 4	Ply 1	DRB GROUP - 122 FaNC Job Reference (optional)	150955711
-----------------	--------------	----------------------------	----------	----------	--	-----------

Carter Components (Sanford), Sanford, NC - 27332,

Run: 8.53 S Dec 6 2021 Print: 8.530 S Dec 6 2021 MiTek Industries, Inc. Wed Mar 23 16:52:29
ID:EvevzESfZUuPvgppuvhwMjyGMOW-RfC?PsB70Hq3NSgPqnl8w3uITXbGKwRCDoi7J4zJC?f

Page: 1

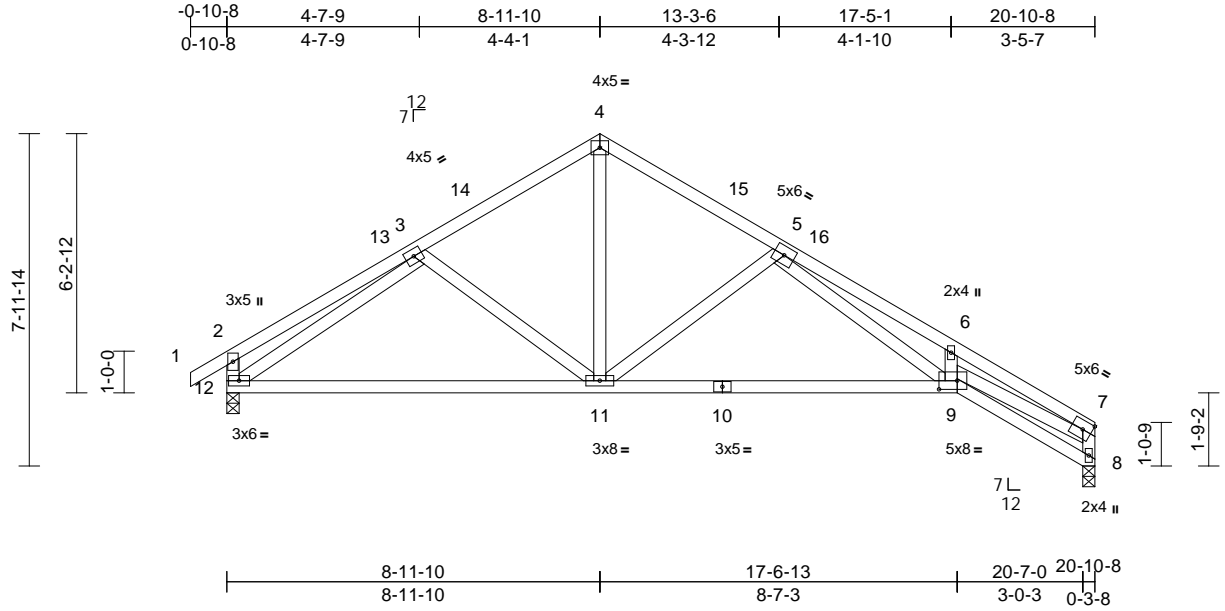

Scale = 1:55.4

Plate Offsets (X, Y): [9:0-5-4,0-2-8]

Loading	(psf)	Spacing	2-0-0	CSI	DEFL	in	(loc)	l/defl	L/d	PLATES	GRIP	
TCLL (roof)	20.0	Plate Grip DOL	1.15	TC	0.48	Vert(LL)	-0.17	9-11	>999	240	MT20	244/190
Snow (Pf)	20.0	Lumber DOL	1.15	BC	0.86	Vert(CT)	-0.41	9-11	>607	180		
TCDL	10.0	Rep Stress Incr	YES	WB	0.64	Horz(CT)	0.17	8	n/a	n/a		
BCLL	0.0*	Code	IRC2018/TPI2014	Matrix-MSH								
BCDL	10.0											
											Weight: 117 lb	FT = 20%

LUMBER

TOP CHORD 2x4 SP No.2
 BOT CHORD 2x4 SP No.2
 WEBS 2x4 SP No.3 *Except* 9-7:2x4 SP No.2

BRACING

TOP CHORD Structural wood sheathing directly applied or 2-11-9 oc purlins, except end verticals.
 BOT CHORD Rigid ceiling directly applied or 10-0-0 oc bracing.

REACTIONS

(lb/size) 8=822/0-3-8, 12=886/0-3-8
 Max Horiz 12=182 (LC 13)
 Max Uplift 8=-87 (LC 15), 12=-83 (LC 14)
 Max Grav 8=873 (LC 22), 12=923 (LC 21)

FORCES

(lb) - Maximum Compression/Maximum Tension
 TOP CHORD 1-2=0/31, 2-3=-284/67, 3-4=-945/134, 4-5=-1006/134, 5-6=-2911/355, 6-7=-2956/242, 7-8=-902/112, 2-12=-303/96
 BOT CHORD 11-12=-76/913, 9-11=-39/1298, 8-9=-36/160
 WEBS 3-11=-250/164, 4-11=-36/624, 5-11=-673/199, 5-9=-203/1543, 6-9=-155/142, 7-9=-154/2454, 3-12=-941/94

NOTES

- Unbalanced roof live loads have been considered for this design.
- Wind: ASCE 7-16; Vult=130mph (3-second gust) Vasd=103mph; TCDL=6.0psf; BCDL=6.0psf; h=25ft; Cat. II; Exp B; Enclosed; MWFRS (envelope) exterior zone and C-C Exterior(2E) -0-10-8 to 2-1-8, Interior (1) 2-1-8 to 5-11-10, Exterior(2R) 5-11-10 to 11-11-10, Interior (1) 11-11-10 to 17-8-12, Exterior(2E) 17-8-12 to 20-8-12 zone; cantilever left and right exposed; end vertical left and right exposed; C-C for members and forces & MWFRS for reactions shown; Lumber DOL=1.60 plate grip DOL=1.60

- TCLL: ASCE 7-16; Pr=20.0 psf (roof LL: Lum DOL=1.15 Plate DOL=1.15); Pf=20.0 psf (Lum DOL=1.15 Plate DOL=1.15); Is=1.0; Rough Cat B; Fully Exp.; Ce=0.9; Cs=1.00; Ct=1.10
- Unbalanced snow loads have been considered for this design.
- This truss has been designed for greater of min roof live load of 12.0 psf or 1.00 times flat roof load of 20.0 psf on overhangs non-concurrent with other live loads.
- This truss has been designed for a 10.0 psf bottom chord live load nonconcurrent with any other live loads.
- * This truss has been designed for a live load of 20.0psf on the bottom chord in all areas where a rectangle 3-06-00 tall by 2-00-00 wide will fit between the bottom chord and any other members.
- Bearing at joint(s) 8 considers parallel to grain value using ANSI/TPI 1 angle to grain formula. Building designer should verify capacity of bearing surface.
- One H2.5A Simpson Strong-Tie connectors recommended to connect truss to bearing walls due to UPLIFT at jt(s) 8 and 12. This connection is for uplift only and does not consider lateral forces.
- This truss is designed in accordance with the 2018 International Residential Code sections R502.11.1 and R802.10.2 and referenced standard ANSI/TPI 1.

LOAD CASE(S) Standard

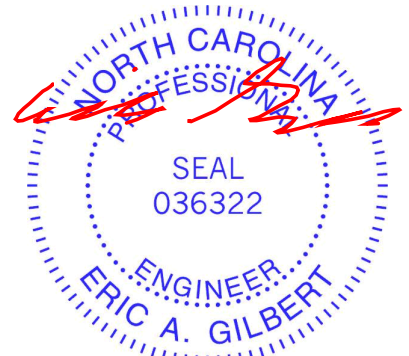

March 24, 2022

WARNING - Verify design parameters and READ NOTES ON THIS AND INCLUDED MITEK REFERENCE PAGE MII-7473 rev. 5/19/2020 BEFORE USE.

Design valid for use only with MiTek® connectors. This design is based only upon parameters shown, and is for an individual building component, not a truss system. Before use, the building designer must verify the applicability of design parameters and properly incorporate this design into the overall building design. Bracing indicated is to prevent buckling of individual truss web and/or chord members only. Additional temporary and permanent bracing is always required for stability and to prevent collapse with possible personal injury and property damage. For general guidance regarding the fabrication, storage, delivery, erection and bracing of trusses and truss systems, see ANSITPI Quality Criteria, DSB-89 and BCSI Building Component Safety Information available from Truss Plate Institute, 2670 Crain Highway, Suite 203 Waldorf, MD 20601



818 Soundside Road
 Edenton, NC 27932

Job 22020083	Truss C02	Truss Type Roof Special Supported Gable	Qty 1	Ply 1	DRB GROUP - 122 FaNC Job Reference (optional)	150955712
-----------------	--------------	--	----------	----------	--	-----------

Carter Components (Sanford), Sanford, NC - 27332,

Run: 8.53 S Dec 6 2021 Print: 8.530 S Dec 6 2021 MiTek Industries, Inc. Wed Mar 23 16:52:30
ID:sph12DEfKafPe1af4A8ZVyGMDe-RfC?PsB70Hq3NSgPqnlL8w3uTXbGKwRcDoi7J4zJC7f

Page: 1

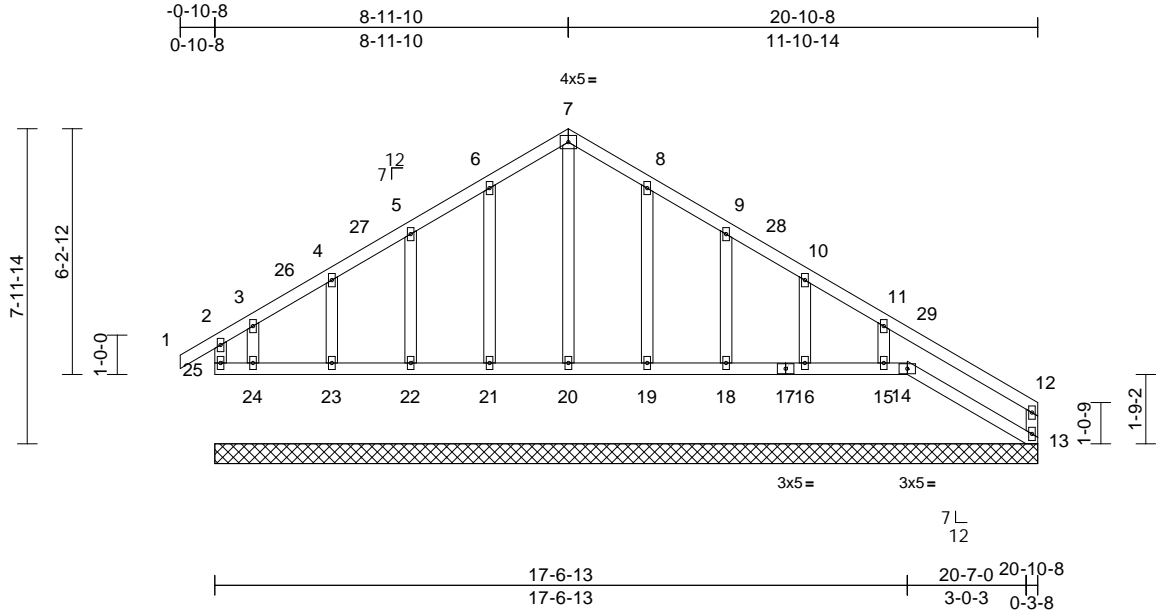

Scale = 1:58.4

Loading	(psf)	Spacing	1-11-4	CSI	DEFL	in	(loc)	l/defl	L/d	PLATES	GRIP	
TCLL (roof)	20.0	Plate Grip DOL	1.15	TC	0.16	Vert(LL)	n/a	-	n/a	999	MT20	244/190
Snow (Pf)	20.0	Lumber DOL	1.15	BC	0.08	Vert(CT)	n/a	-	n/a	999		
TCDL	10.0	Rep Stress Incr	YES	WB	0.14	Horz(CT)	0.00	13	n/a	n/a		
BCLL	0.0*	Code	IRC2018/TPI2014	Matrix-MR								
BCDL	10.0											
											Weight: 113 lb	FT = 20%

LUMBER
TOP CHORD 2x4 SP No.2
BOT CHORD 2x4 SP No.2
WEBS 2x4 SP No.3
OTHERS 2x4 SP No.3

BRACING
TOP CHORD Structural wood sheathing directly applied or 6-0-0 oc purlins, except end verticals.
BOT CHORD Rigid ceiling directly applied or 10-0-0 oc bracing.

REACTIONS (lb/size)
13=126/20-10-8, 14=70/20-10-8, 15=219/20-10-8, 16=120/20-10-8, 18=162/20-10-8, 19=159/20-10-8, 20=110/20-10-8, 21=161/20-10-8, 22=152/20-10-8, 23=165/20-10-8, 24=51/20-10-8, 25=159/20-10-8
Max Horiz 25=176 (LC 13)
Max Uplift 13=21 (LC 15), 15=119 (LC 15), 16=20 (LC 15), 18=58 (LC 15), 19=44 (LC 15), 20=17 (LC 13), 21=48 (LC 14), 22=51 (LC 14), 23=47 (LC 14), 24=145 (LC 11), 25=194 (LC 10)
Max Grav 13=132 (LC 25), 14=110 (LC 7), 15=230 (LC 25), 16=126 (LC 22), 18=228 (LC 22), 19=242 (LC 22), 20=205 (LC 15), 21=245 (LC 21), 22=217 (LC 21), 23=170 (LC 21), 24=196 (LC 12), 25=271 (LC 25)

FORCES (lb) - Maximum Compression/Maximum Tension
TOP CHORD 2-25=-199/136, 1-2=0/30, 2-3=-198/177, 3-4=-150/146, 4-5=-142/177, 5-6=-145/227, 6-7=-171/274, 7-8=-171/274, 8-9=-146/228, 9-10=-115/173, 10-11=-105/141, 11-12=-87/50, 12-13=-117/68

BOT CHORD 24-25=-25/49, 23-24=-25/49, 22-23=-25/49, 21-22=-25/49, 20-21=-25/49, 19-20=-25/49, 18-19=-25/49, 16-18=-25/49, 15-16=-25/49, 14-15=-25/49, 13-14=-37/71
WEBS 7-20=-215/85, 6-21=-206/72, 5-22=-179/77, 4-23=-128/82, 3-24=-105/94, 8-19=-203/68, 9-18=-190/86, 10-16=-85/44, 11-15=-226/157

- NOTES**
- Unbalanced roof live loads have been considered for this design.
 - Wind: ASCE 7-16; Vult=130mph (3-second gust) Vasd=103mph; TCDL=6.0psf; BCDL=6.0psf; h=25ft; Cat. II; Exp B; Enclosed; MWFRS (envelope) exterior zone and C-C Corner(3E) -0-10-8 to 2-1-8, Exterior(2N) 2-1-8 to 5-11-10, Corner(3R) 5-11-10 to 11-11-10, Exterior(2N) 11-11-10 to 17-8-12, Corner(3E) 17-8-12 to 20-8-12 zone; cantilever left and right exposed; end vertical left and right exposed; C/C for members and forces & MWFRS for reactions shown; Lumber DOL=1.60 plate grip DOL=1.60
 - Truss designed for wind loads in the plane of the truss only. For studs exposed to wind (normal to the face), see Standard Industry Gable End Details as applicable, or consult qualified building designer as per ANSI/TPI 1.
 - TCLL: ASCE 7-16; Pr=20.0 psf (roof LL: Lum DOL=1.15 Plate DOL=1.15); Pf=20.0 psf (Lum DOL=1.15 Plate DOL=1.15); Is=1.0; Rough Cat B; Fully Exp.; Ce=0.9; Cs=1.00; Ct=1.10
 - Unbalanced snow loads have been considered for this design.
 - This truss has been designed for greater of min roof live load of 12.0 psf or 1.00 times flat roof load of 20.0 psf on overhangs non-concurrent with other live loads.
 - All plates are 2x4 MT20 unless otherwise indicated.
 - Gable requires continuous bottom chord bearing.
 - Truss to be fully sheathed from one face or securely braced against lateral movement (i.e. diagonal web).
 - Gable studs spaced at 2-0-0 oc.

- This truss has been designed for a 10.0 psf bottom chord live load nonconcurrent with any other live loads.
- * This truss has been designed for a live load of 20.0psf on the bottom chord in all areas where a rectangle 3-06-00 tall by 2-00-00 wide will fit between the bottom chord and any other members.
- N/A

- Beveled plate or shim required to provide full bearing surface with truss chord at joint(s) 25, 14, 20, 21, 22, 23, 24, 19, 18, 16, 15.
- This truss is designed in accordance with the 2018 International Residential Code sections R502.11.1 and R802.10.2 and referenced standard ANSI/TPI 1.

LOAD CASE(S) Standard

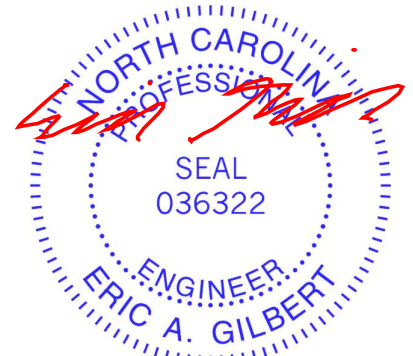

March 24, 2022

WARNING - Verify design parameters and READ NOTES ON THIS AND INCLUDED MITEK REFERENCE PAGE MII-7473 rev. 5/19/2020 BEFORE USE.

Design valid for use only with MiTek® connectors. This design is based only upon parameters shown, and is for an individual building component, not a truss system. Before use, the building designer must verify the applicability of design parameters and properly incorporate this design into the overall building design. Bracing indicated is to prevent buckling of individual truss web and/or chord members only. Additional temporary and permanent bracing is always required for stability and to prevent collapse with possible personal injury and property damage. For general guidance regarding the fabrication, storage, delivery, erection and bracing of trusses and truss systems, see **ANSI/TPI1 Quality Criteria, DSB-89 and BCSI Building Component Safety Information** available from Truss Plate Institute, 2670 Crain Highway, Suite 203 Waldorf, MD 20601



818 Soundside Road
Edenton, NC 27932

Job 22020083	Truss D01	Truss Type Monopitch	Qty 4	Ply 1	DRB GROUP - 122 FaNC Job Reference (optional)	150955713
-----------------	--------------	-------------------------	----------	----------	--	-----------

Carter Components (Sanford), Sanford, NC - 27332,

Run: 8.53 S Dec 6 2021 Print: 8.530 S Dec 6 2021 MiTek Industries, Inc. Wed Mar 23 16:52:31
ID:duDvsaOamEtiR5Ee7uw_GLyGMD_-RfC?PsB70Hq3NSgPqnL8w3uITXbGKWrCDoi7J4zJC7f

Page: 1

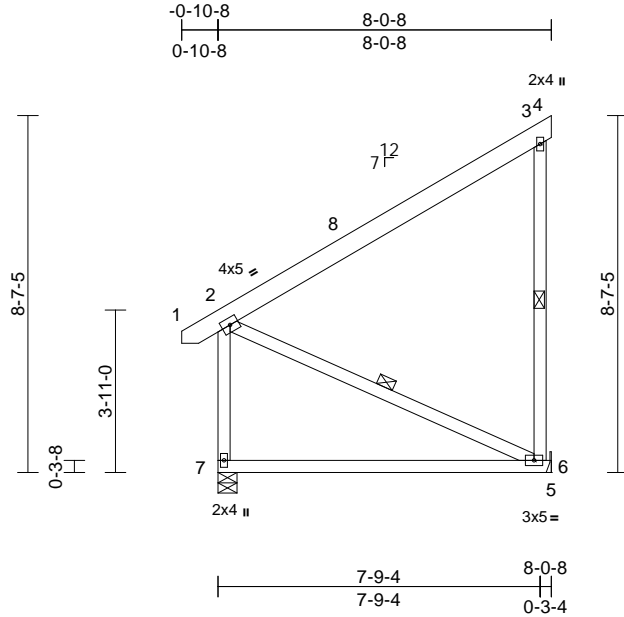

Scale = 1:55.6

Loading	(psf)	Spacing	2-0-0	CSI	DEFL	in	(loc)	l/defl	L/d	PLATES	GRIP	
TCLL (roof)	20.0	Plate Grip DOL	1.15	TC	0.73	Vert(LL)	0.33	6-7	>277	240	MT20	244/190
Snow (Pf)	20.0	Lumber DOL	1.15	BC	0.38	Vert(CT)	-0.28	6-7	>323	180		
TCDL	10.0	Rep Stress Incr	YES	WB	0.06	Horz(CT)	0.00	6	n/a	n/a		
BCLL	0.0*	Code	IRC2018/TPI2014	Matrix-MP								
BCDL	10.0											
											Weight: 65 lb	FT = 20%

LUMBER
TOP CHORD 2x6 SP No.2
BOT CHORD 2x4 SP 2400F 2.0E
WEBS 2x4 SP No.3 *Except* 3-6:2x4 SP No.2

BRACING
TOP CHORD Structural wood sheathing directly applied or 6-0-0 oc purlins, except end verticals.
BOT CHORD Rigid ceiling directly applied or 10-0-0 oc bracing.
WEBS 1 Row at midpt 3-6, 2-6

REACTIONS (lb/size) 6=324/ Mechanical, 7=356/0-5-8
Max Horiz 7=292 (LC 11)
Max Uplift 6=-142 (LC 11), 7=-66 (LC 10)
Max Grav 6=459 (LC 21), 7=411 (LC 21)

FORCES (lb) - Maximum Compression/Maximum Tension
TOP CHORD 1-2=0/25, 2-3=-189/139, 3-4=-13/0,
3-6=-377/110, 2-7=-335/129
BOT CHORD 6-7=-277/191, 5-6=0/0
WEBS 2-6=-160/218

- This truss has been designed for greater of min roof live load of 12.0 psf or 1.00 times flat roof load of 20.0 psf on overhangs non-concurrent with other live loads.
- This truss has been designed for a 10.0 psf bottom chord live load nonconcurrent with any other live loads.
- * This truss has been designed for a live load of 20.0psf on the bottom chord in all areas where a rectangle 3-06-00 tall by 2-00-00 wide will fit between the bottom chord and any other members.
- Refer to girder(s) for truss to truss connections.
- Provide mechanical connection (by others) of truss to bearing plate capable of withstanding 142 lb uplift at joint 6.
- One H2.5A Simpson Strong-Tie connectors recommended to connect truss to bearing walls due to UPLIFT at jt(s) 7. This connection is for uplift only and does not consider lateral forces.
- This truss is designed in accordance with the 2018 International Residential Code sections R502.11.1 and R802.10.2 and referenced standard ANSI/TPI 1.

LOAD CASE(S) Standard

- NOTES**
- Wind: ASCE 7-16; Vult=130mph (3-second gust)
Vasd=103mph; TCDL=6.0psf; BCDL=6.0psf; h=25ft;
Cat. II; Exp B; Enclosed; MWFRS (envelope) exterior zone and C-C Exterior(2E) 5-1-3 to 8-1-3, Interior (1) 8-1-3 to 10-9-12, Exterior(2E) 10-9-12 to 13-9-12 zone; cantilever left and right exposed; end vertical left and right exposed; porch left exposed; C-C for members and forces & MWFRS for reactions shown; Lumber DOL=1.60 plate grip DOL=1.60
 - TCLL: ASCE 7-16; Pr=20.0 psf (roof LL: Lum DOL=1.15 Plate DOL=1.15); Pf=20.0 psf (Lum DOL=1.15 Plate DOL=1.15); Is=1.0; Rough Cat B; Fully Exp.; Ce=0.9; Cs=1.00; Ct=1.10
 - Unbalanced snow loads have been considered for this design.



March 24, 2022

WARNING - Verify design parameters and READ NOTES ON THIS AND INCLUDED MITEK REFERENCE PAGE MII-7473 rev. 5/19/2020 BEFORE USE.

Design valid for use only with MiTek® connectors. This design is based only upon parameters shown, and is for an individual building component, not a truss system. Before use, the building designer must verify the applicability of design parameters and properly incorporate this design into the overall building design. Bracing indicated is to prevent buckling of individual truss web and/or chord members only. Additional temporary and permanent bracing is always required for stability and to prevent collapse with possible personal injury and property damage. For general guidance regarding the fabrication, storage, delivery, erection and bracing of trusses and truss systems, see **ANSI/TPI1 Quality Criteria, DSB-89 and BCSI Building Component Safety Information** available from Truss Plate Institute, 2670 Crain Highway, Suite 203 Waldorf, MD 20601



818 Soundside Road
Edenton, NC 27932

Job 22020083	Truss D02	Truss Type Monopitch Structural Gable	Qty 1	Ply 1	DRB GROUP - 122 FaNC Job Reference (optional)	150955714
-----------------	--------------	--	----------	----------	--	-----------

Carter Components (Sanford), Sanford, NC - 27332,

Run: 8.53 S Dec 6 2021 Print: 8.530 S Dec 6 2021 MiTek Industries, Inc. Wed Mar 23 16:52:31
ID:HcyRNhX5xwO?tx9yqQ80ltyGMCo-RfC?PsB70Hq3NSgPqnL8w3uITXbGKwKRCDoi7J4zJC?f

Page: 1

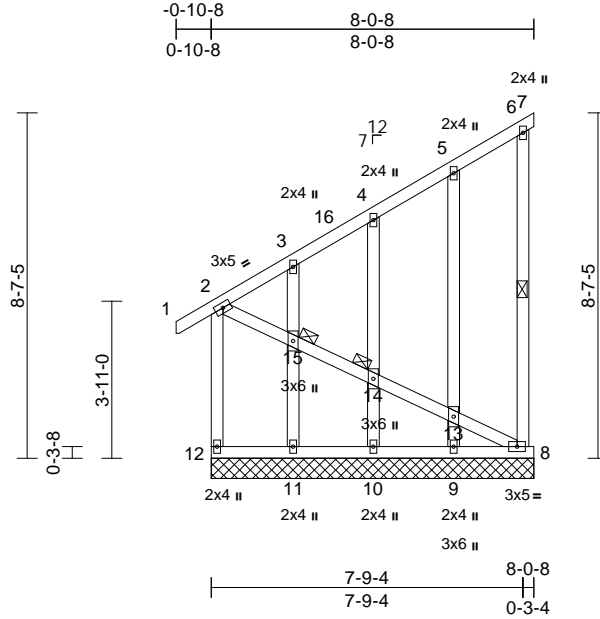

Scale = 1:57.4

Loading	(psf)	Spacing	1-11-4	CSI	DEFL	in	(loc)	l/defl	L/d	PLATES	GRIP	
TCLL (roof)	20.0	Plate Grip DOL	1.15	TC	0.69	Vert(LL)	n/a	-	n/a	999	MT20	244/190
Snow (Pf)	20.0	Lumber DOL	1.15	BC	0.04	Vert(CT)	n/a	-	n/a	999		
TCDL	10.0	Rep Stress Incr	YES	WB	0.15	Horz(CT)	0.00	8	n/a	n/a		
BCLL	0.0*	Code	IRC2018/TPI2014	Matrix-MP								
BCDL	10.0											
											Weight: 81 lb	FT = 20%

LUMBER

TOP CHORD 2x4 SP No.2
 BOT CHORD 2x4 SP No.2
 WEBS 2x4 SP No.3 *Except* 6-8:2x4 SP No.2
 OTHERS 2x4 SP No.3

BRACING

TOP CHORD Structural wood sheathing directly applied or 6-0-0 oc purlins, except end verticals.
 BOT CHORD Rigid ceiling directly applied or 10-0-0 oc bracing.

WEBS 1 Row at midpt 6-8
 JOINTS 1 Brace at Jt(s): 14, 15

REACTIONS (lb/size)

8=69/8-0-8, 9=157/8-0-8,
 10=157/8-0-8, 11=148/8-0-8,
 12=133/8-0-8

Max Horiz 12=288 (LC 13)
 Max Uplift 8=-140 (LC 11), 9=-43 (LC 14),
 10=-53 (LC 14), 11=-40 (LC 14),
 12=-82 (LC 10)

Max Grav 8=141 (LC 24), 9=234 (LC 21),
 10=223 (LC 21), 11=154 (LC 24),
 12=215 (LC 29)

FORCES (lb) - Maximum Compression/Maximum Tension

TOP CHORD 1-2=0/29, 2-3=-170/108, 3-4=-161/104,
 4-5=-148/101, 5-6=-147/144, 6-7=-13/0,
 6-8=-93/54, 2-12=-200/90

BOT CHORD 11-12=-272/187, 10-11=-272/187,
 9-10=-272/187, 8-9=-272/187

WEBS 2-15=-158/215, 14-15=-158/215,
 13-14=-158/215, 8-13=-161/219,
 5-13=-193/101, 9-13=-194/94,
 4-14=-186/109, 10-14=-185/109,
 3-15=-123/82, 11-15=-122/82

- 1) Wind: ASCE 7-16; Vult=130mph (3-second gust) Vasd=103mph; TCDL=6.0psf; BCDL=6.0psf; h=25ft; Cat. II; Exp B; Enclosed; MWFRS (envelope) exterior zone and C-C Exterior(2E) 4-11-4 to 7-9-12, Interior (1) 7-9-12 to 10-9-12, Exterior(2E) 10-9-12 to 13-9-12 zone; cantilever left and right exposed; end vertical left and right exposed; porch left exposed; C-C for members and forces & MWFRS for reactions shown; Lumber DOL=1.60 plate grip DOL=1.60
- 2) Truss designed for wind loads in the plane of the truss only. For studs exposed to wind (normal to the face), see Standard Industry Gable End Details as applicable, or consult qualified building designer as per ANSI/TPI 1.
- 3) TCLL: ASCE 7-16; Pr=20.0 psf (roof LL: Lum DOL=1.15 Plate DOL=1.15); Pf=20.0 psf (Lum DOL=1.15 Plate DOL=1.15); Is=1.0; Rough Cat B; Fully Exp.; Ce=0.9; Cs=1.00; Ct=1.10
- 4) Unbalanced snow loads have been considered for this design.
- 5) This truss has been designed for greater of min roof live load of 12.0 psf or 1.00 times flat roof load of 20.0 psf on overhangs non-concurrent with other live loads.
- 6) All plates are 2x4 MT20 unless otherwise indicated.
- 7) Gable requires continuous bottom chord bearing.
- 8) Truss to be fully sheathed from one face or securely braced against lateral movement (i.e. diagonal web).
- 9) Gable studs spaced at 2-0-0 oc.
- 10) This truss has been designed for a 10.0 psf bottom chord live load nonconcurrent with any other live loads.
- 11) * This truss has been designed for a live load of 20.0psf on the bottom chord in all areas where a rectangle 3-06-00 tall by 2-00-00 wide will fit between the bottom chord and any other members.
- 12) N/A

13) This truss is designed in accordance with the 2018 International Residential Code sections R502.11.1 and R802.10.2 and referenced standard ANSI/TPI 1.

LOAD CASE(S) Standard



March 24, 2022

WARNING - Verify design parameters and READ NOTES ON THIS AND INCLUDED MITEK REFERENCE PAGE MII-7473 rev. 5/19/2020 BEFORE USE.

Design valid for use only with MiTek® connectors. This design is based only upon parameters shown, and is for an individual building component, not a truss system. Before use, the building designer must verify the applicability of design parameters and properly incorporate this design into the overall building design. Bracing indicated is to prevent buckling of individual truss web and/or chord members only. Additional temporary and permanent bracing is always required for stability and to prevent collapse with possible personal injury and property damage. For general guidance regarding the fabrication, storage, delivery, erection and bracing of trusses and truss systems, see ANSITPI Quality Criteria, DSB-89 and BCSI Building Component Safety Information available from Truss Plate Institute, 2670 Crain Highway, Suite 203 Waldorf, MD 20601



818 Soundside Road
Edenton, NC 27932

Job 22020083	Truss F01	Truss Type Monopitch	Qty 2	Ply 1	DRB GROUP - 122 FaNC Job Reference (optional)	150955715
-----------------	--------------	-------------------------	----------	----------	--	-----------

Carter Components (Sanford), Sanford, NC - 27332,

Run: 8.53 S Dec 6 2021 Print: 8.530 S Dec 6 2021 MiTek Industries, Inc. Wed Mar 23 16:52:32
ID:a5wx_i1pHWYAIeOqkXNQwXyGMC9-RfC?PsB70Hq3NSgPqnL8w3ulTXbGKwRCDoi7J4zJC?f

Page: 1

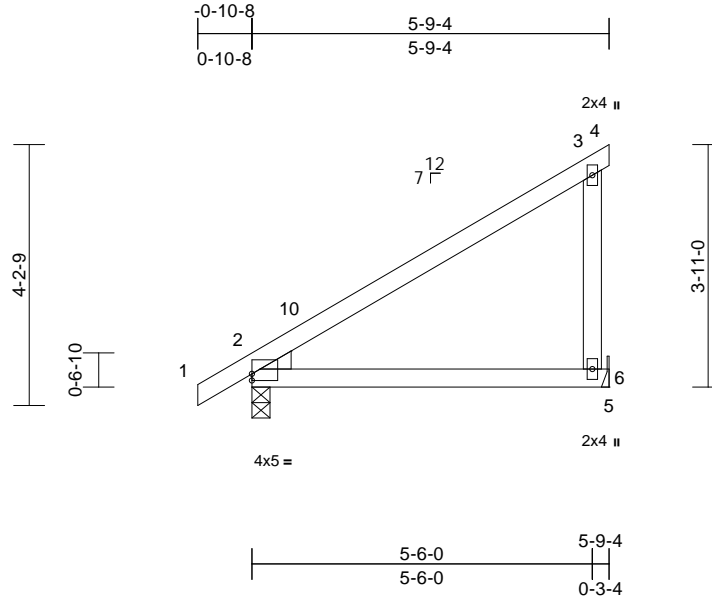

Scale = 1:37.2

Plate Offsets (X, Y): [2:Edge,0-1-5]

Loading	(psf)	Spacing	2-0-0	CSI	DEFL	in	(loc)	l/defl	L/d	PLATES	GRIP
TCLL (roof)	20.0	Plate Grip DOL	1.15	TC	Vert(LL)	0.15	6-9	>440	240	MT20	244/190
Snow (Pf)	20.0	Lumber DOL	1.15	BC	Vert(CT)	-0.12	6-9	>541	180		
TCDL	10.0	Rep Stress Incr	YES	WB	Horz(CT)	0.02	2	n/a	n/a		
BCLL	0.0*	Code	IRC2018/TPI2014	Matrix-MP							
BCDL	10.0									Weight: 26 lb	FT = 20%

- LUMBER**
- TOP CHORD 2x4 SP No.2
 - BOT CHORD 2x4 SP No.2
 - WEBS 2x4 SP No.3
 - WEDGE Left: 2x4 SP No.3
- BRACING**
- TOP CHORD Structural wood sheathing directly applied or 5-9-4 oc purlins, except end verticals.
 - BOT CHORD Rigid ceiling directly applied or 10-0-0 oc bracing.
- REACTIONS** (lb/size) 2=276/0-3-8, 6=238/ Mechanical
 Max Horiz 2=131 (LC 13)
 Max Uplift 2=30 (LC 14), 6=77 (LC 11)
 Max Grav 2=352 (LC 21), 6=352 (LC 21)
- FORCES** (lb) - Maximum Compression/Maximum Tension
- TOP CHORD 1-2=0/26, 2-3=-154/195, 3-4=-13/0, 3-6=-263/130
 - BOT CHORD 2-6=-187/230, 5-6=0/0

- This truss has been designed for greater of min roof live load of 12.0 psf or 1.00 times flat roof load of 20.0 psf on overhangs non-concurrent with other live loads.
- This truss has been designed for a 10.0 psf bottom chord live load nonconcurrent with any other live loads.
- * This truss has been designed for a live load of 20.0psf on the bottom chord in all areas where a rectangle 3-06-00 tall by 2-00-00 wide will fit between the bottom chord and any other members.
- Refer to girder(s) for truss to truss connections.
- Provide mechanical connection (by others) of truss to bearing plate capable of withstanding 77 lb uplift at joint 6.
- H10A Simpson Strong-Tie connectors recommended to connect truss to bearing walls due to UPLIFT at jt(s) 2. This connection is for uplift only and does not consider lateral forces.
- This truss is designed in accordance with the 2018 International Residential Code sections R502.11.1 and R802.10.2 and referenced standard ANSI/TPI 1.

LOAD CASE(S) Standard

- NOTES**
- Wind: ASCE 7-16; Vult=130mph (3-second gust) Vasd=103mph; TCDL=6.0psf; BCDL=6.0psf; h=25ft; Cat. II; Exp B; Enclosed; MWFRS (envelope) exterior zone and C-C Exterior(2E) -0-10-8 to 2-1-8, Interior (1) 2-1-8 to 2-9-4, Exterior(2E) 2-9-4 to 5-9-4 zone; cantilever left and right exposed; end vertical left and right exposed; porch left and right exposed; C-C for members and forces & MWFRS for reactions shown; Lumber DOL=1.60 plate grip DOL=1.60
 - TCLL: ASCE 7-16; Pr=20.0 psf (roof LL: Lum DOL=1.15 Plate DOL=1.15); Pf=20.0 psf (Lum DOL=1.15 Plate DOL=1.15); Is=1.0; Rough Cat B; Fully Exp.; Ce=0.9; Cs=1.00; Ct=1.10
 - Unbalanced snow loads have been considered for this design.



March 24, 2022

WARNING - Verify design parameters and READ NOTES ON THIS AND INCLUDED MITEK REFERENCE PAGE MII-7473 rev. 5/19/2020 BEFORE USE.
 Design valid for use only with MiTek® connectors. This design is based only upon parameters shown, and is for an individual building component, not a truss system. Before use, the building designer must verify the applicability of design parameters and properly incorporate this design into the overall building design. Bracing indicated is to prevent buckling of individual truss web and/or chord members only. Additional temporary and permanent bracing is always required for stability and to prevent collapse with possible personal injury and property damage. For general guidance regarding the fabrication, storage, delivery, erection and bracing of trusses and truss systems, see **ANSI/TPI1 Quality Criteria, DSB-89 and BCSI Building Component Safety Information** available from Truss Plate Institute, 2670 Crain Highway, Suite 203 Waldorf, MD 20601



Job 22020083	Truss F02	Truss Type Monopitch Supported Gable	Qty 1	Ply 1	DRB GROUP - 122 FaNC Job Reference (optional)	150955716
-----------------	--------------	---	----------	----------	--	-----------

Carter Components (Sanford), Sanford, NC - 27332,

Run: 8.53 S Dec 6 2021 Print: 8.530 S Dec 6 2021 MiTek Industries, Inc. Wed Mar 23 16:52:32
ID:a5wx_11pHWYAIeokXNQwXyGMC9-RfC?PsB70Hq3NSgPqnL8w3ulTXbGKwRCDoi7J4zJC?f

Page: 1

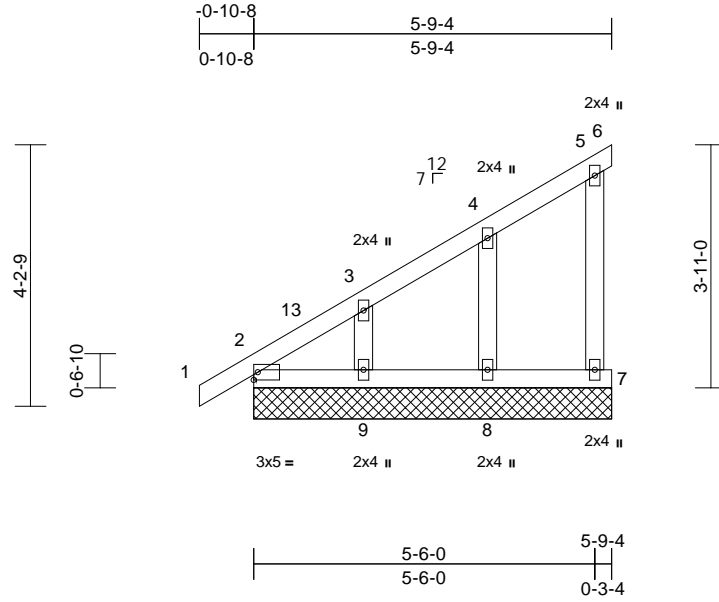

Loading	(psf)	Spacing	2-0-0	CSI	DEFL	in	(loc)	l/defl	L/d	PLATES	GRIP	
TCLL (roof)	20.0	Plate Grip DOL	1.15	TC	0.20	Vert(LL)	n/a	-	n/a	999	MT20	244/190
Snow (Pf)	20.0	Lumber DOL	1.15	BC	0.03	Vert(CT)	n/a	-	n/a	999		
TCDL	10.0	Rep Stress Incr	YES	WB	0.04	Horz(CT)	0.00	6	n/a	n/a		
BCLL	0.0*	Code	IRC2018/TPI2014	Matrix-MP								
BCDL	10.0										Weight: 30 lb	FT = 20%

LUMBER
TOP CHORD 2x4 SP No.2
BOT CHORD 2x4 SP No.2
WEBS 2x4 SP No.3
OTHERS 2x4 SP No.3

BRACING
TOP CHORD Structural wood sheathing directly applied or 5-9-4 oc purlins, except end verticals.
BOT CHORD Rigid ceiling directly applied or 10-0-0 oc bracing.

REACTIONS (lb/size)
2=123/5-9-4, 6=4/5-9-4,
7=75/5-9-4, 8=165/5-9-4,
9=149/5-9-4, 10=123/5-9-4
Max Horiz 2=130 (LC 13), 10=130 (LC 13)
Max Uplift 2=-10 (LC 10), 6=-10 (LC 13),
7=-22 (LC 14), 8=-45 (LC 14),
9=-66 (LC 14), 10=-10 (LC 10)
Max Grav 2=129 (LC 25), 6=9 (LC 14), 7=115
(LC 21), 8=244 (LC 21), 9=219 (LC
21), 10=129 (LC 25)

FORCES (lb) - Maximum Compression/Maximum Tension
TOP CHORD 1-2=0/26, 2-3=-119/73, 3-4=-82/59,
4-5=-69/43, 5-6=-17/9, 5-7=-102/46
BOT CHORD 2-9=-98/64, 8-9=-59/64, 7-8=-59/64
WEBS 4-8=-202/125, 3-9=-180/126

NOTES
1) Wind: ASCE 7-16; Vult=130mph (3-second gust)
Vasd=103mph; TCDL=6.0psf; BCDL=6.0psf; h=25ft;
Cat. II; Exp B; Enclosed; MWFRS (envelope) exterior
zone and C-C Exterior(2E) -0-10-8 to 2-1-8, Interior (1)
2-1-8 to 5-9-4 zone; cantilever left and right exposed ;
end vertical left and right exposed; porch left and right
exposed;C-C for members and forces & MWFRS for
reactions shown; Lumber DOL=1.60 plate grip
DOL=1.60

- Truss designed for wind loads in the plane of the truss only. For studs exposed to wind (normal to the face), see Standard Industry Gable End Details as applicable, or consult qualified building designer as per ANSI/TPI 1.
- TCLL: ASCE 7-16; Pr=20.0 psf (roof LL: Lum DOL=1.15 Plate DOL=1.15); Pf=20.0 psf (Lum DOL=1.15 Plate DOL=1.15); Is=1.0; Rough Cat B; Fully Exp.; Ce=0.9; Cs=1.00; Ct=1.10
- Unbalanced snow loads have been considered for this design.
- This truss has been designed for greater of min roof live load of 12.0 psf or 1.00 times flat roof load of 20.0 psf on overhangs non-concurrent with other live loads.
- Gable requires continuous bottom chord bearing.
- Gable studs spaced at 2-0-0 oc.
- This truss has been designed for a 10.0 psf bottom chord live load nonconcurrent with any other live loads.
- * This truss has been designed for a live load of 20.0psf on the bottom chord in all areas where a rectangle 3-06-00 tall by 2-00-00 wide will fit between the bottom chord and any other members.
- Provide mechanical connection (by others) of truss to bearing plate capable of withstanding 10 lb uplift at joint 6.



March 24, 2022

WARNING - Verify design parameters and READ NOTES ON THIS AND INCLUDED MITEK REFERENCE PAGE MII-7473 rev. 5/19/2020 BEFORE USE.
Design valid for use only with MiTek® connectors. This design is based only upon parameters shown, and is for an individual building component, not a truss system. Before use, the building designer must verify the applicability of design parameters and properly incorporate this design into the overall building design. Bracing indicated is to prevent buckling of individual truss web and/or chord members only. Additional temporary and permanent bracing is always required for stability and to prevent collapse with possible personal injury and property damage. For general guidance regarding the fabrication, storage, delivery, erection and bracing of trusses and truss systems, see **ANSI/TPI1 Quality Criteria, DSB-89 and BCSI Building Component Safety Information** available from Truss Plate Institute, 2670 Crain Highway, Suite 203 Waldorf, MD 20601



Job 22020083	Truss G01	Truss Type Monopitch	Qty 10	Ply 1	DRB GROUP - 122 FaNC Job Reference (optional)	150955717
-----------------	--------------	-------------------------	-----------	----------	--	-----------

Carter Components (Sanford), Sanford, NC - 27332,

Run: 8.53 S Dec 6 2021 Print: 8.530 S Dec 6 2021 MiTek Industries, Inc. Wed Mar 23 16:52:32
ID:ppzLtn8T9Hhvd_Zlw1XnQyGMC0-RfC?PsB70Hq3NSgPqnL8w3ulTXbGKWrCDoi7J4zJC?f

Page: 1

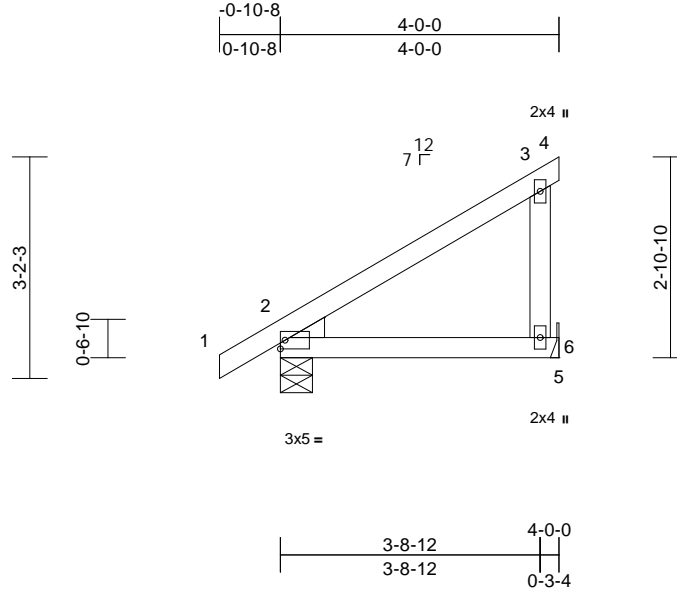

Scale = 1:33.1

Loading	(psf)	Spacing	2-0-0	CSI		DEFL	in	(loc)	l/defl	L/d	PLATES	GRIP
TCLL (roof)	20.0	Plate Grip DOL	1.15	TC	0.31	Vert(LL)	-0.01	6-9	>999	240	MT20	244/190
Snow (Pf)	20.0	Lumber DOL	1.15	BC	0.18	Vert(CT)	-0.02	6-9	>999	180		
TCDL	10.0	Rep Stress Incr	YES	WB	0.00	Horz(CT)	0.01	2	n/a	n/a		
BCLL	0.0*	Code	IRC2018/TPI2014	Matrix-MP								
BCDL	10.0										Weight: 19 lb	FT = 20%

LUMBER
TOP CHORD 2x4 SP No.2
BOT CHORD 2x4 SP No.2
WEBS 2x4 SP No.3
WEDGE Left: 2x4 SP No.3

BRACING
TOP CHORD Structural wood sheathing directly applied or 4-0-0 oc purlins, except end verticals.
BOT CHORD Rigid ceiling directly applied or 10-0-0 oc bracing.

REACTIONS (lb/size) 2=207/0-5-8, 6=165/ Mechanical
Max Horiz 2=94 (LC 13)
Max Uplift 2=-25 (LC 14), 6=-41 (LC 14)
Max Grav 2=315 (LC 21), 6=243 (LC 21)

FORCES (lb) - Maximum Compression/Maximum Tension
TOP CHORD 1-2=0/43, 2-3=-139/123, 3-4=-13/0, 3-6=-184/72
BOT CHORD 2-6=-118/80, 5-6=0/0

- NOTES**
- 1) Wind: ASCE 7-16; Vult=130mph (3-second gust) Vasd=103mph; TCDL=6.0psf; BCDL=6.0psf; h=25ft; Cat. II; Exp B; Enclosed; MWFRS (envelope) exterior zone and C-C Exterior(2E) zone; cantilever left and right exposed; end vertical left and right exposed; C-C for members and forces & MWFRS for reactions shown; Lumber DOL=1.60 plate grip DOL=1.60
 - 2) TCLL: ASCE 7-16; Pr=20.0 psf (roof LL: Lum DOL=1.15 Plate DOL=1.15); Pf=20.0 psf (Lum DOL=1.15 Plate DOL=1.15); Is=1.0; Rough Cat B; Fully Exp.; Ce=0.9; Cs=1.00; Ct=1.10
 - 3) Unbalanced snow loads have been considered for this design.
 - 4) This truss has been designed for greater of min roof live load of 12.0 psf or 1.00 times flat roof load of 20.0 psf on overhangs non-concurrent with other live loads.
 - 5) This truss has been designed for a 10.0 psf bottom chord live load nonconcurrent with any other live loads.

- 6) * This truss has been designed for a live load of 20.0psf on the bottom chord in all areas where a rectangle 3-06-00 tall by 2-00-00 wide will fit between the bottom chord and any other members.
 - 7) Refer to girder(s) for truss to truss connections.
 - 8) Provide mechanical connection (by others) of truss to bearing plate capable of withstanding 41 lb uplift at joint 6.
 - 9) H10A Simpson Strong-Tie connectors recommended to connect truss to bearing walls due to UPLIFT at jt(s) 2. This connection is for uplift only and does not consider lateral forces.
 - 10) This truss is designed in accordance with the 2018 International Residential Code sections R502.11.1 and R802.10.2 and referenced standard ANSI/TPI 1.
- LOAD CASE(S)** Standard



March 24, 2022

WARNING - Verify design parameters and READ NOTES ON THIS AND INCLUDED MITEK REFERENCE PAGE MII-7473 rev. 5/19/2020 BEFORE USE.

Design valid for use only with MiTek® connectors. This design is based only upon parameters shown, and is for an individual building component, not a truss system. Before use, the building designer must verify the applicability of design parameters and properly incorporate this design into the overall building design. Bracing indicated is to prevent buckling of individual truss web and/or chord members only. Additional temporary and permanent bracing is always required for stability and to prevent collapse with possible personal injury and property damage. For general guidance regarding the fabrication, storage, delivery, erection and bracing of trusses and truss systems, see

Safety Information available from Truss Plate Institute, 2670 Crain Highway, Suite 203 Waldorf, MD 20601

ANSI/TPI1 Quality Criteria, DSB-89 and BCSI Building Component



818 Soundside Road
Edenton, NC 27932

Job 22020083	Truss G02	Truss Type Monopitch Supported Gable	Qty 2	Ply 1	DRB GROUP - 122 FaNC Job Reference (optional)	150955718
-----------------	--------------	---	----------	----------	--	-----------

Carter Components (Sanford), Sanford, NC - 27332,

Run: 8.53 S Dec 6 2021 Print: 8.530 S Dec 6 2021 MiTek Industries, Inc. Wed Mar 23 16:52:33
ID:I:C56HT9jhuxc7w7ytl4?stryGMC_-RFC?PsB70Hq3NSgPqnL8w3uITXbGKwRcDoi7J4zJC?f

Page: 1

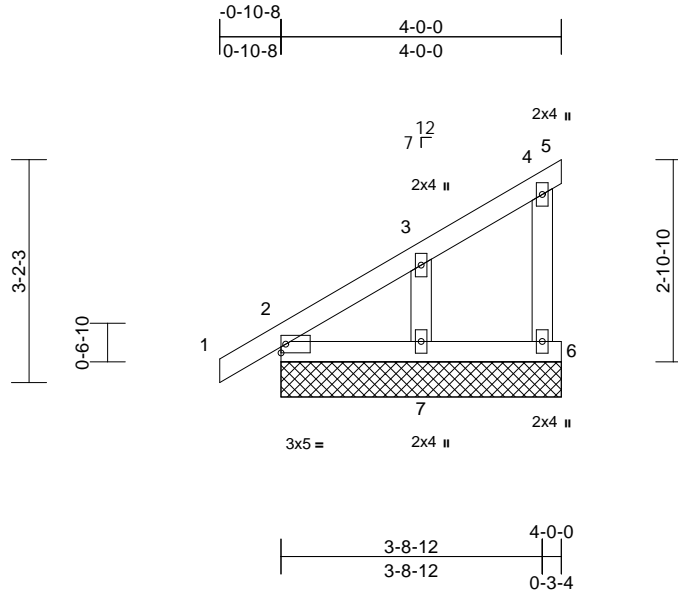

Loading	(psf)	Spacing	2-0-0	CSI	DEFL	in	(loc)	l/defl	L/d	PLATES	GRIP	
TCLL (roof)	20.0	Plate Grip DOL	1.15	TC	0.12	Vert(LL)	n/a	-	n/a	999	MT20	244/190
Snow (Pf)	20.0	Lumber DOL	1.15	BC	0.04	Vert(CT)	n/a	-	n/a	999		
TCDL	10.0	Rep Stress Incr	YES	WB	0.05	Horz(CT)	0.00	5	n/a	n/a		
BCLL	0.0*	Code	IRC2018/TPI2014	Matrix-MP								
BCDL	10.0											
										Weight: 20 lb	FT = 20%	

LUMBER
TOP CHORD 2x4 SP No.2
BOT CHORD 2x4 SP No.2
WEBS 2x4 SP No.3
OTHERS 2x4 SP No.3

BRACING
TOP CHORD Structural wood sheathing directly applied or 4-0-0 oc purlins, except end verticals.
BOT CHORD Rigid ceiling directly applied or 10-0-0 oc bracing.

REACTIONS (lb/size)
2=130/4-0-0, 5=10/4-0-0,
6=82/4-0-0, 7=165/4-0-0,
8=130/4-0-0
Max Horiz 2=94 (LC 13), 8=94 (LC 13)
Max Uplift 5=-17 (LC 21), 6=-23 (LC 14),
7=-61 (LC 14)
Max Grav 2=203 (LC 21), 5=8 (LC 14), 6=127 (LC 21),
7=240 (LC 21), 8=203 (LC 21)

FORCES (lb) - Maximum Compression/Maximum Tension
TOP CHORD 1-2=0/43, 2-3=-110/70, 3-4=-57/36,
4-5=-22/9, 4-6=-115/57
BOT CHORD 2-7=-71/56, 6-7=-42/56
WEBS 3-7=-194/172

NOTES
1) Wind: ASCE 7-16; Vult=130mph (3-second gust) Vasd=103mph; TCDL=6.0psf; BCDL=6.0psf; h=25ft; Cat. II; Exp B; Enclosed; MWFRS (envelope) exterior zone and C-C Corner(3E) -0-10-8 to 2-0-0, Exterior(2N) 2-0-0 to 4-0-0 zone; cantilever left and right exposed; end vertical left and right exposed; C-C for members and forces & MWFRS for reactions shown; Lumber DOL=1.60 plate grip DOL=1.60
2) Truss designed for wind loads in the plane of the truss only. For studs exposed to wind (normal to the face), see Standard Industry Gable End Details as applicable, or consult qualified building designer as per ANSI/TPI 1.

- TCLL: ASCE 7-16; Pr=20.0 psf (roof LL: Lum DOL=1.15 Plate DOL=1.15); Pf=20.0 psf (Lum DOL=1.15 Plate DOL=1.15); Is=1.0; Rough Cat B; Fully Exp.; Ce=0.9; Cs=1.00; Ct=1.10
- Unbalanced snow loads have been considered for this design.
- This truss has been designed for greater of min roof live load of 12.0 psf or 1.00 times flat roof load of 20.0 psf on overhangs non-concurrent with other live loads.
- Gable requires continuous bottom chord bearing.
- Gable studs spaced at 2-0-0 oc.
- This truss has been designed for a 10.0 psf bottom chord live load nonconcurrent with any other live loads.
- * This truss has been designed for a live load of 20.0psf on the bottom chord in all areas where a rectangle 3-06-00 tall by 2-00-00 wide will fit between the bottom chord and any other members.
- Provide mechanical connection (by others) of truss to bearing plate capable of withstanding 17 lb uplift at joint 5.
- N/A
- Beveled plate or shim required to provide full bearing surface with truss chord at joint(s) 2, 8.
- This truss is designed in accordance with the 2018 International Residential Code sections R502.11.1 and R802.10.2 and referenced standard ANSI/TPI 1.

LOAD CASE(S) Standard



March 24, 2022

WARNING - Verify design parameters and READ NOTES ON THIS AND INCLUDED MITEK REFERENCE PAGE MII-7473 rev. 5/19/2020 BEFORE USE.

Design valid for use only with MiTek® connectors. This design is based only upon parameters shown, and is for an individual building component, not a truss system. Before use, the building designer must verify the applicability of design parameters and properly incorporate this design into the overall building design. Bracing indicated is to prevent buckling of individual truss web and/or chord members only. Additional temporary and permanent bracing is always required for stability and to prevent collapse with possible personal injury and property damage. For general guidance regarding the fabrication, storage, delivery, erection and bracing of trusses and truss systems, see

ANSI/TPI1 Quality Criteria, DSB-89 and BCSI Building Component

Safety Information available from Truss Plate Institute, 2670 Crain Highway, Suite 203 Waldorf, MD 20601



818 Soundside Road
Edenton, NC 27932

Symbols

PLATE LOCATION AND ORIENTATION

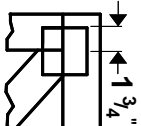

Center plate on joint unless x, y offsets are indicated. Dimensions are in ft-in-sixteenths. Apply plates to both sides of truss and fully embed teeth.

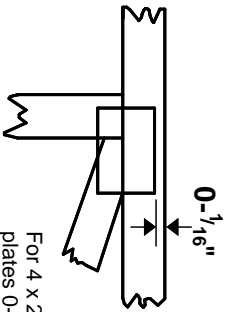

For 4 x 2 orientation, locate plates 0- 1/16" from outside edge of truss.



This symbol indicates the required direction of slots in connector plates.

* Plate location details available in **MITek 20/20 software** or upon request.

PLATE SIZE

4 X 4

The first dimension is the plate width measured perpendicular to slots. Second dimension is the length parallel to slots.

LATERAL BRACING LOCATION



Indicated by symbol shown and/or by text in the bracing section of the output. Use T or I bracing if indicated.

BEARING



Indicates location where bearings (supports) occur. Icons vary but reaction section indicates joint number where bearings occur. Min size shown is for crushing only.

Industry Standards:

ANSI/TFP1: National Design Specification for Metal Plate Connected Wood Truss Construction.
DSB-89: Design Standard for Bracing, Building Component Safety Information, Guide to Good Practice for Handling, Installing & Bracing of Metal Plate Connected Wood Trusses.

Numbering System

6-4-8
dimensions shown in ft-in-sixteenths
(Drawings not to scale)



JOINTS ARE GENERALLY NUMBERED/LETTERED CLOCKWISE AROUND THE TRUSS STARTING AT THE JOINT FARTHEST TO THE LEFT.

CHORDS AND WEBS ARE IDENTIFIED BY END JOINT NUMBERS/LETTERS.

PRODUCT CODE APPROVALS

ICC-ES Reports:

ESR-1311, ESR-1352, ESR1988
ER-3907, ESR-2362, ESR-1397, ESR-3282

Trusses are designed for wind loads in the plane of the truss unless otherwise shown.

Lumber design values are in accordance with ANSI/TFP 1 section 6.3 These truss designs rely on lumber values established by others.

© 2012 MITteK® All Rights Reserved



MITek Engineering Reference Sheet: MII-7473 rev. 5/19/2020



General Safety Notes

Failure to Follow Could Cause Property Damage or Personal Injury

1. Additional stability bracing for truss system, e.g. diagonal or X-bracing, is always required. See BCSI.
2. Truss bracing must be designed by an engineer. For wide truss spacing, individual lateral braces themselves may require bracing, or alternative Tor I bracing should be considered.
3. Never exceed the design loading shown and never stack materials on inadequately braced trusses.
4. Provide copies of this truss design to the building designer, erection supervisor, property owner and all other interested parties.
5. Cut members to bear tightly against each other.
6. Place plates on each face of truss at each joint and embed fully. Knots and wane at joint locations are regulated by ANSI/TFP 1.
7. Design assumes trusses will be suitably protected from the environment in accord with ANSI/TFP 1.
8. Unless otherwise noted, moisture content of lumber shall not exceed 19% at time of fabrication.
9. Unless expressly noted, this design is not applicable for use with fire retardant, preservative treated, or green lumber.
10. Camber is a non-structural consideration and is the responsibility of truss fabricator. General practice is to camber for dead load deflection.
11. Plate type, size, orientation and location dimensions indicated are minimum plating requirements.
12. Lumber used shall be of the species and size, and in all respects, equal to or better than that specified.
13. Top chords must be sheathed or purlins provided at spacing indicated on design.
14. Bottom chords require lateral bracing at 10 ft. spacing, or less, if no ceiling is installed, unless otherwise noted.
15. Connections not shown are the responsibility of others.
16. Do not cut or alter truss member or plate without prior approval of an engineer.
17. Install and load vertically unless indicated otherwise.
18. Use of green or treated lumber may pose unacceptable environmental, health or performance risks. Consult with project engineer before use.
19. Review all portions of this design (front, back, words and pictures) before use. Rewriting pictures alone is not sufficient.
20. Design assumes manufacture in accordance with ANSI/TFP 1 Quality Criteria.
21. The design does not take into account any dynamic or other loads other than those expressly stated.