

Crossing 49 - CORNER- Pinnacle Dr, Spring Lake, 28390

Harnett County

Created: 4/8/2022

House Plan: Havenbrooke

Elevation: A

Stone/Brick Option: #1

Foundation: Slab

Foundation Finish: 3 Sides Parged

Garage Hand: Left

Garage: 2 Car Front

Garage Door:(2) 8x8

Front Porch: Concrete

Roof: Truss

Siding: Vinyl

Ceiling Height 1st Floor: 9'

Ceiling Height 2nd Floor: 9'

Door Frame Height 1st Floor: 83"

Door Frame Height 2nd Floor: 83"

Windows 1st Floor: 6/0 Front Only

Windows 2nd Floor: 5/0

OPTIONS

Covered Porch

Trey Ceiling in Master Bedroom

Trey Ceiling in Dining Room

Total Heated Sq. Ft.: 2189

Total Unheated Sq. Ft.: 809

Total SQ FT: 2997

Bedrooms: 3 + Rec Room

Full Bathrooms: 2

Half Bathrooms: 1



DYNAMIC DESIGN GROUP, INC
 David D Grorud
 (919) 601-1406
 DynamicDesignGroup@gmail.com
 www.DDGhomeplans.com

The drawings and specifications (plans) contained on these pages are the property of Dynamic Design Group and are offered to the named client or contractor for a conditional one time use. The conditional use is limited to the lot and subdivision specified herein, and only for said location. COPYRIGHT 2020

Contractor shall verify all conditions and dimensions prior to construction. Any error or omissions shall be reported to Dynamic Design Group for corrections or justification. Once construction has commenced, the contractor shall assume all responsibility. Dimensions govern over scale, code governs over dimensions.

CAPITOL
 PROJECT FOR: CITY HOMES
 LOCATION: MULTI
 LOT: MULTI
 SUBDIVISION: MULTI
 COUNTY: MULTI

HAVENBROOKE
 PLAN NAME
 C-2190-35GL
 PLAN I.D.
 3-25-20
 DATE

A-1A
SHEET

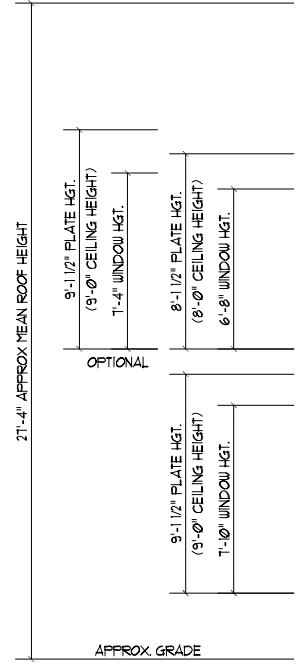

FRONT ELEVATION "A"

SCALE: -----1/8" = 1'-0"
HARDI FRONT

THIS PLAN CONFORMS TO THE 2018 EDITION OF THE I.R.C. / NORTH CAROLINA RESIDENTIAL CODE.

Stone/Brick Location

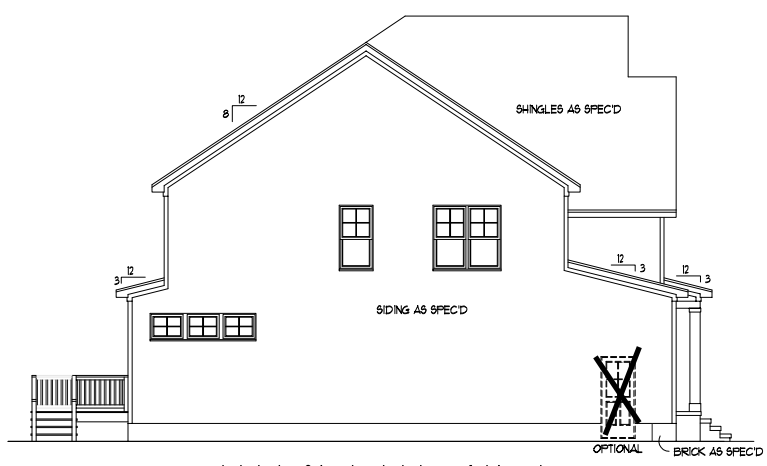

LEFT SIDE ELEVATION

SCALE: -----1/16" = 1'-0"



REAR ELEVATION

SCALE: -----1/16" = 1'-0"

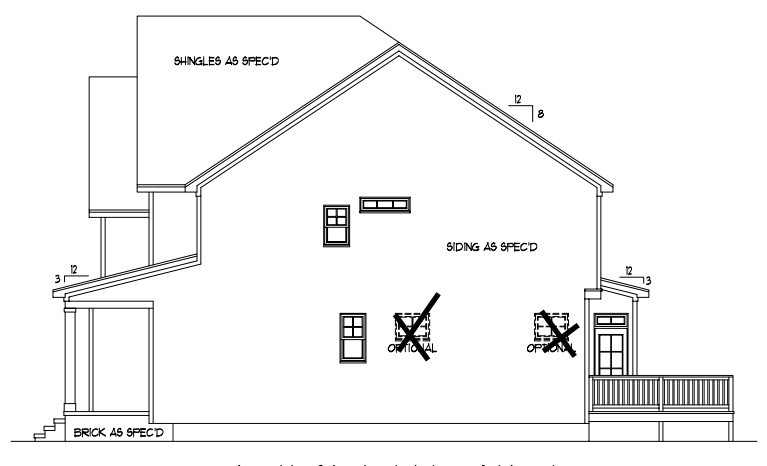

RIGHT SIDE ELEVATION

SCALE: -----1/16" = 1'-0"

The drawings and specifications (plans) contained on these pages are the property of Dynamic Design Group and are offered to the named client or contractor for a conditional one time use. The conditional use is limited to the lot and subdivision specified herein, and only for said location. COPYRIGHT 2020
 Contractor shall verify all conditions and dimensions prior to construction. Any error or omissions shall be reported to Dynamic Design Group for corrections or justification. Once construction has commenced, the contractor shall assume all responsibility. Dimensions govern over scale, code governs over dimensions.

CAPITOL PROJECT FOR: CITY HOMES
 LOCATION: MULTI
 LOT: MULTI
 SUBDIVISION: MULTI
 COUNTY: MULTI

HAVENBROOKE
 PLAN NAME
C-2190-35GL 3-25-20
 PLAN I.D. DATE

A-2
 SHEET

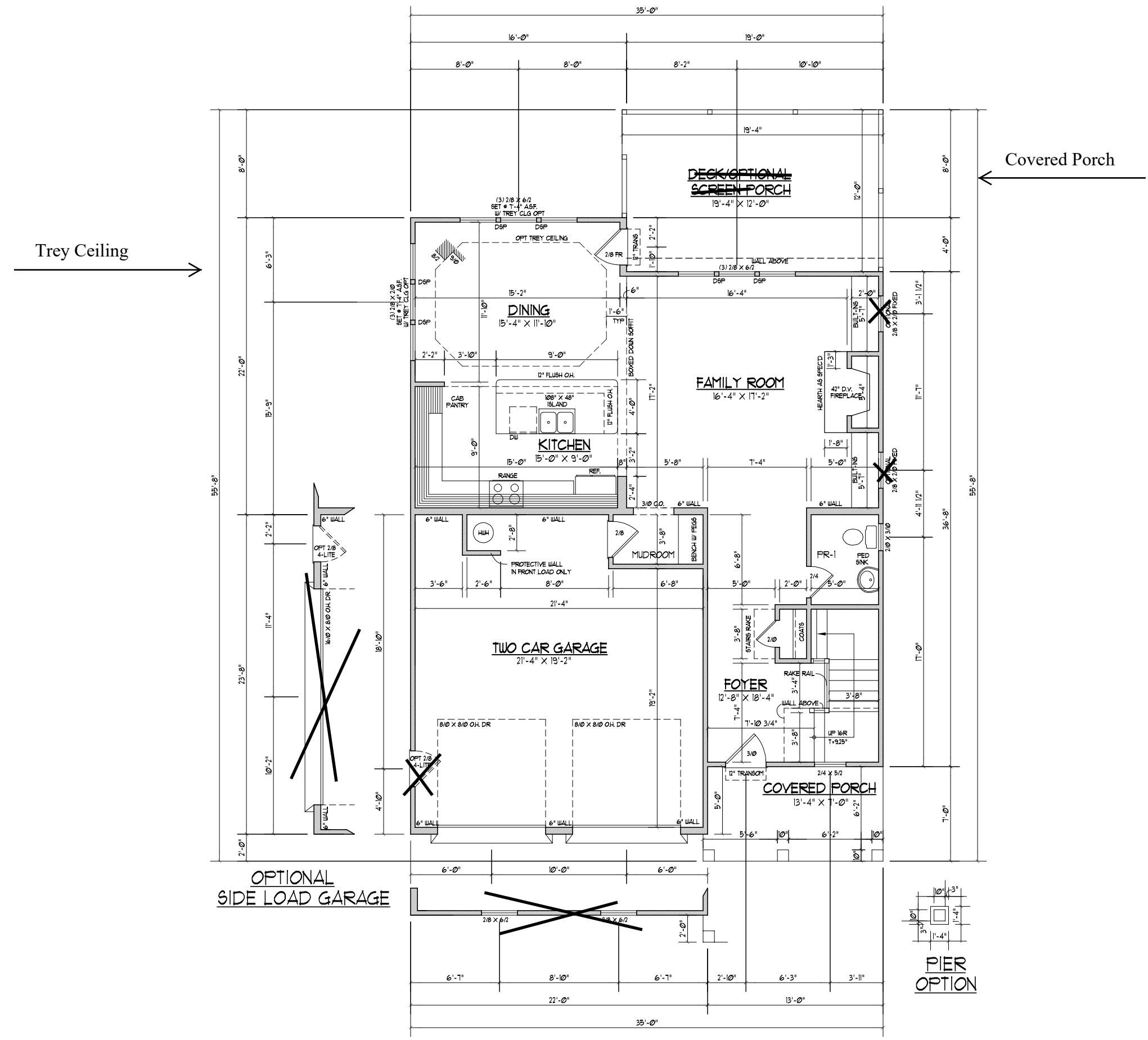

FIRST FLOOR PLAN
 SCALE: ----- 1/8" = 1'-0"

921 HEATED SQ. FT.
486 SQ. FT. GARAGE
93 SQ. FT. COVERED PORCH
231 SQ. FT. DECK/OPT. SCREEN PORCH
125 SQ. FT. OPTIONAL BBQ DECK

- NOTES:
- 1) 9'-0" CLG. HGT. (9' - 1 1/2" FLT. HGT.) UNLESS OTHERWISE NOTED.
 - 2) ALL WALLS FIGURED AT 4" WIDTHS UNLESS OTHERWISE NOTED.
 - 3) SET WINDOWS AT 1"-10" A.S.F. UNLESS OTHERWISE NOTED.
 - 4) DIMENSIONS ARE TO FRAMING UNLESS OTHERWISE NOTED.
 - 5) CONSULT WINDOW MANUFACTURER'S SPECS. FOR EGRESS REQUIREMENTS, PRESSURE RATINGS, & ROUGH OPENINGS.

OPT SCREEN PORCH/BBQ DECK

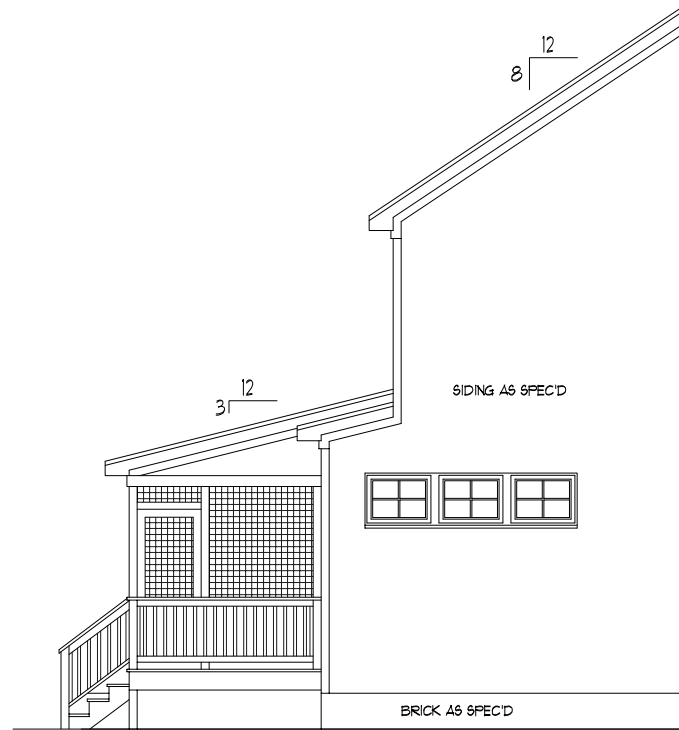

LEFT SIDE ELEVATION



REAR ELEVATION
SCALE: ----- 1/8" = 1'-0"

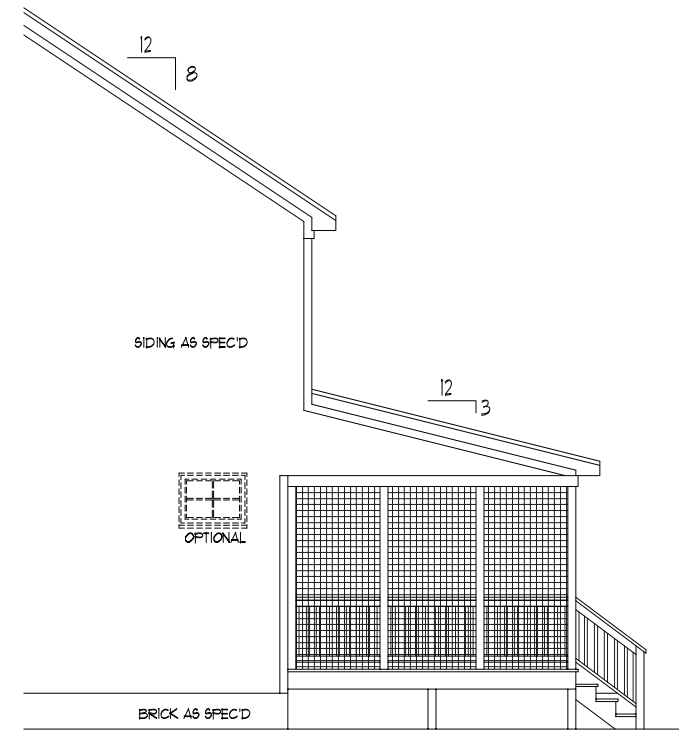

RIGHT SIDE ELEVATION

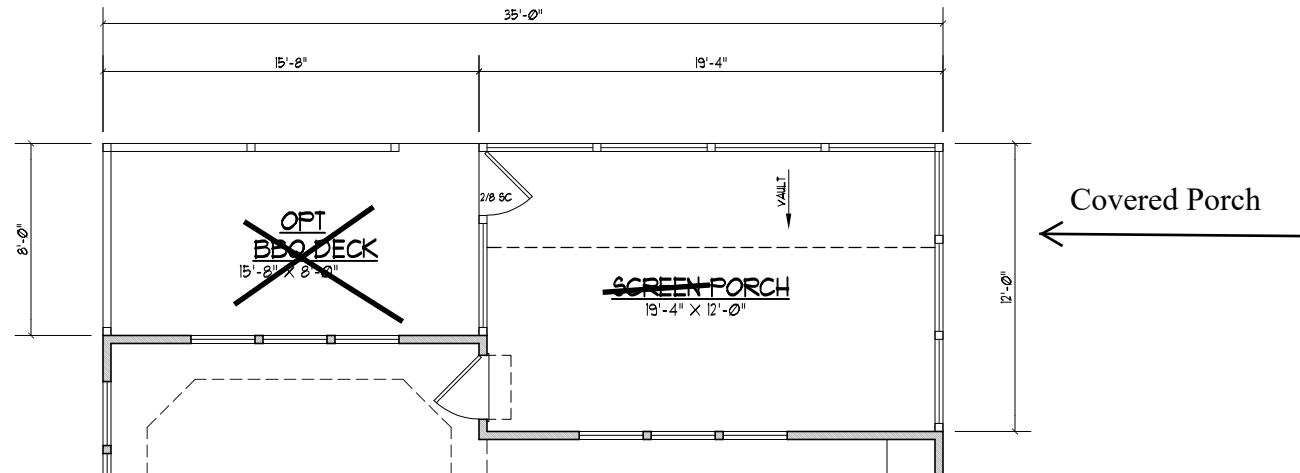

FLOOR PLAN
SCALE: ----- 1/8" = 1'-0"

**DYNAMIC
DESIGN
GROUP, INC**

David D Grorud
(919) 601-1406
DynamicDesignGroup@gmail.com
www.DDGhomeplans.com

The drawings and specifications (plans) contained on these pages are the property of Dynamic Design Group and are offered to the named client or contractor for a conditional one time use. The conditional use is limited to the lot and subdivision specified herein, and only for said location. COPYRIGHT 2020

Contractor shall verify all conditions and dimensions prior to construction. Any error or omissions shall be reported to Dynamic Design Group for corrections or justification. Once construction has commenced, the contractor shall assume all responsibility. Dimensions govern over scale, code governs over dimensions.

PROJECT FOR: CAPITOL CITY HOMES
LOCATION: MULTI
LOT: MULTI
SUBDIVISION: MULTI
COUNTY: MULTI

HAVENBROOKE
PLAN NAME
C-2190-35GL
PLAN I.D.
DATE
3-25-20

A-2 SCR PORCH / BBQ DECK OPTIONS
SHEET

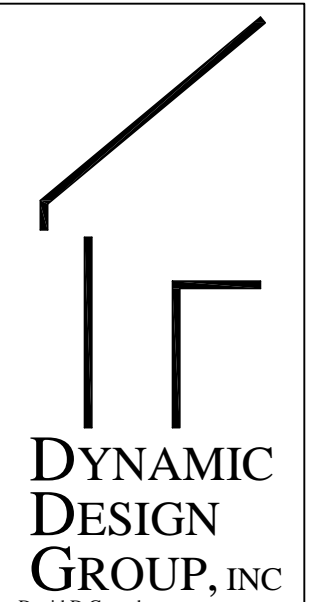

DYNAMIC DESIGN GROUP, INC

David D Grorud
 (919) 601-1406
 DynamicDesignGroup@gmail.com
 www.DDGhomeplans.com

The drawings and specifications (plans) contained on these pages are the property of Dynamic Design Group and are offered to the named client or contractor for a conditional one time use. The conditional use is limited to the lot and subdivision specified herein, and only for said location. COPYRIGHT 2020

Contractor shall verify all conditions and dimensions prior to construction. Any error or omissions shall be reported to Dynamic Design Group for corrections or justification. Once construction has commenced, the contractor shall assume all responsibility.

Dimensions govern over scale, code governs over dimensions.

CAPITOL
 PROJECT FOR: CITY HOMES
 LOCATION: MULTI
 LOT: MULTI
 SUBDIVISION: MULTI
 COUNTY: MULTI

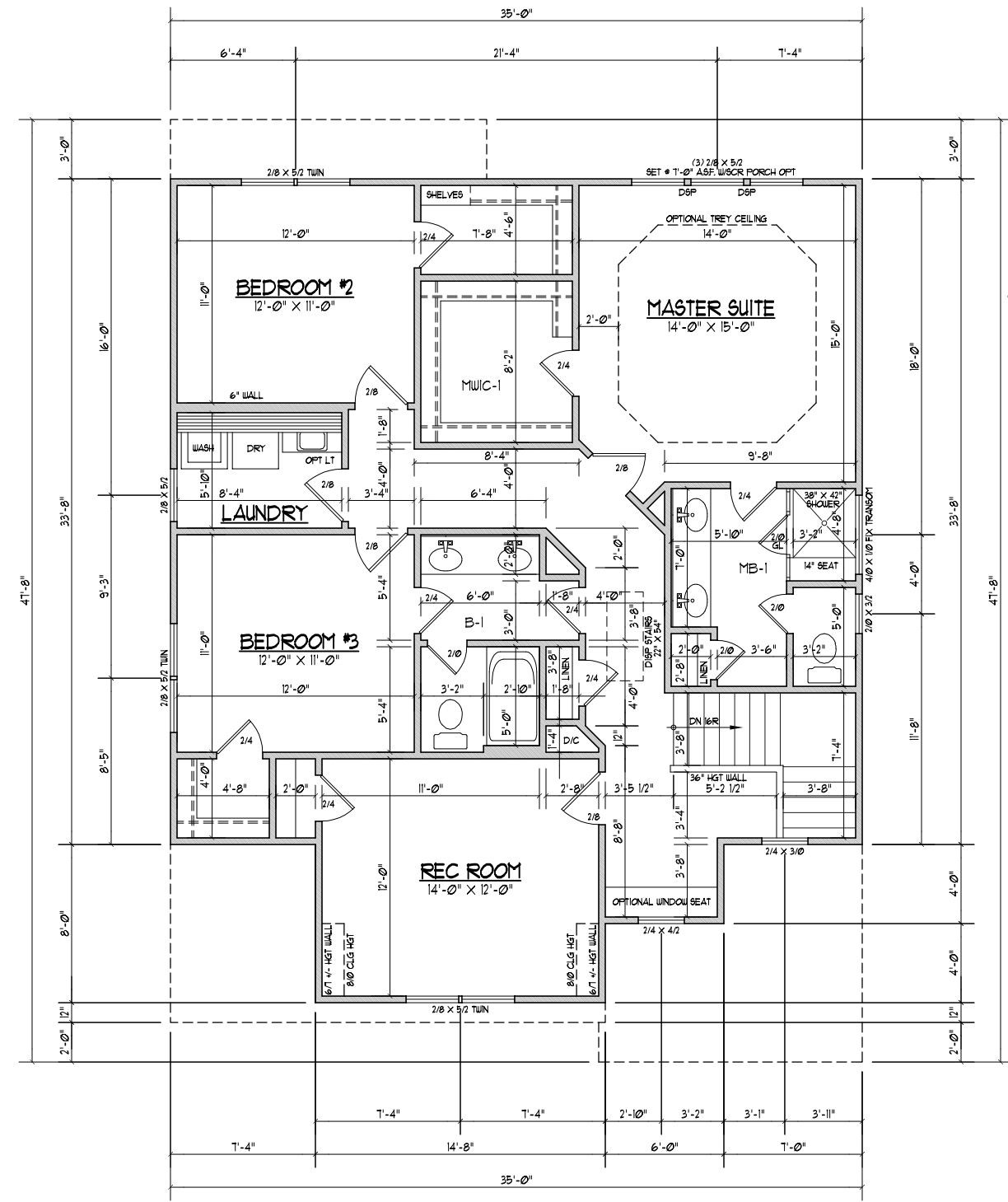

Trey Ceiling

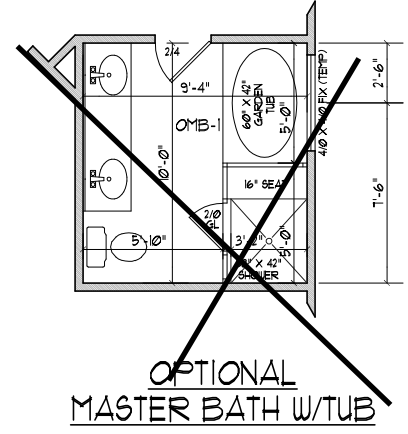

OPTIONAL MASTER BATH W/TUB

**ELEVATION "A"
 SECOND FLOOR PLAN
 WITH REC ROOM**

SCALE 1/8"=1'-0"

1269 HEATED SQ. FT.

- NOTES:
- 1) 8'-0" CLG. HGT. (8' - 1 1/2" FLT. HGT.) UNLESS OTHERWISE NOTED.
 - 2) ALL WALLS FIGURED AT 4" WIDTHS UNLESS OTHERWISE NOTED.
 - 3) SET WINDOWS AT 1'-4" A.S.F. UNLESS OTHERWISE NOTED.
 - 4) DIMENSIONS ARE TO FRAMING UNLESS OTHERWISE NOTED.
 - 5) CONSULT WINDOW MANUFACTURER'S SPECS. FOR EGRESS REQUIREMENTS, PRESSURE RATINGS, & ROUGH OPNG'S.

HAVENBROOKE
 PLAN NAME
C-2190-35GL 3-25-20
 PLAN I.D. DATE

A-3A
 SHEET

OPTIONAL ELECTRICAL ITEMS	
WITH ALL LIGHTS LISTED RESPECTIVE SWITCHES ARE ASSUMED	
RECESSED LIGHTS	
FLUORESCENT LIGHT IN LIEU OF RECESSED CANS @ KITCHEN ONLY	
CEILING FANS IN LIEU OF FLUSH MOUNT	
FLOODLIGHTS	
HANGING LIGHTS @ KITCHEN	
UNDER CABINET LIGHTS	
EXTERIOR LIGHTS AT GARAGE DOOR	

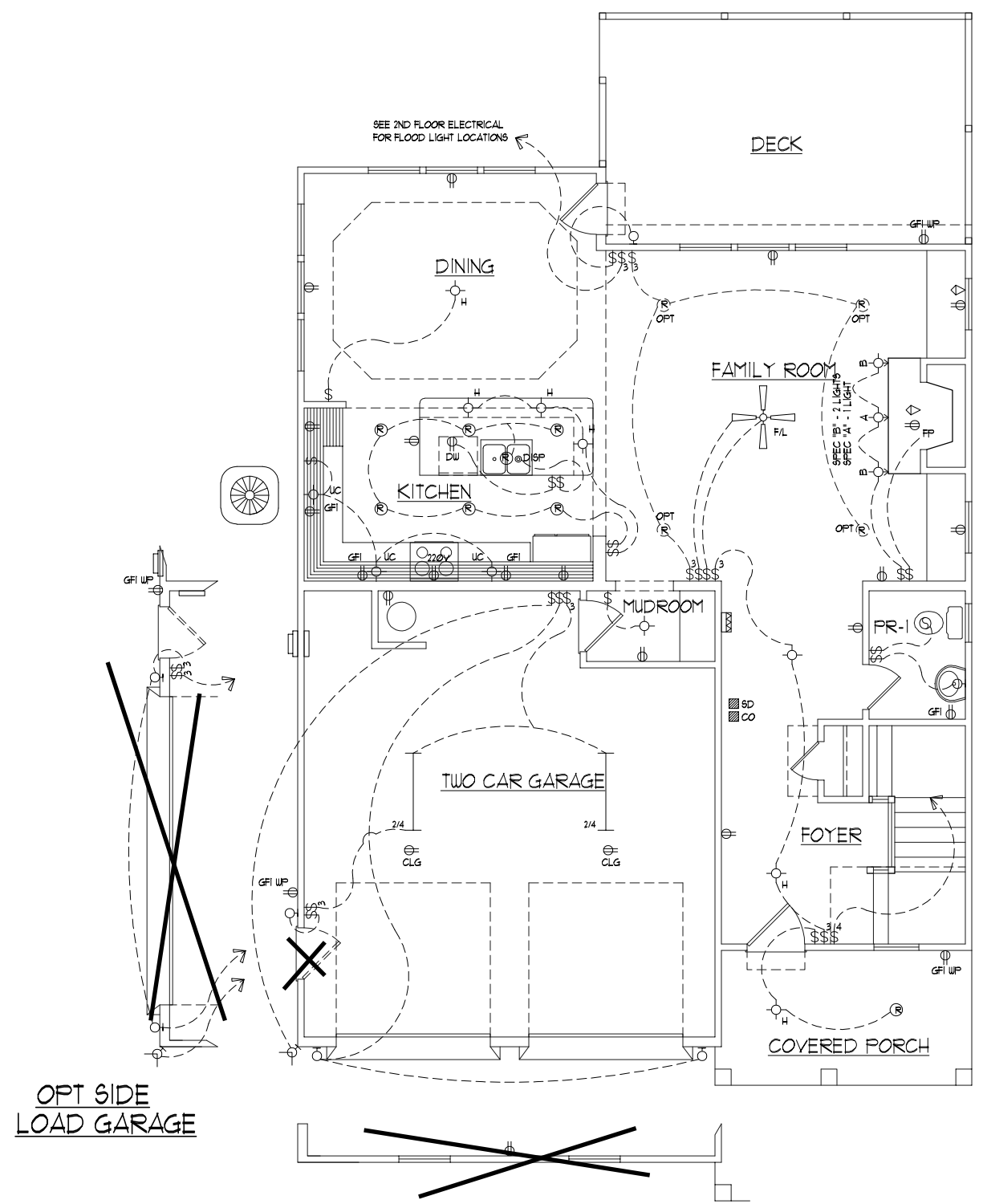

ELECTRICAL SYMBOLS

⊙	CEILING MOUNTED LIGHT FIXTURE	⊙	EXHAUST FAN
⊙	DIRECTIONAL EYEBALL LIGHT FIXTURE	□	RECESSED SHOWER LIGHT
⊙	RECESSED LIGHT FIXTURE	⊙	EXTERIOR FLOOD LIGHT
⊙	MINI RECESSED LIGHT FIXTURE	⊙	SMOKE DETECTOR
⊙	WALL MOUNTED LIGHT FIXTURE	⊙	CARBON MONOXIDE DETECTOR
—	FLUORESCENT LIGHT	—	DOOR CHIMES
	1/2 -- 1 BULB @ 2'	—	ELECTRICAL PANEL
	2/2 -- 2 BULB @ 2'	—	METERBOX
	1/4 -- 1 BULB @ 4'	⊙	A/C UNIT
	2/4 -- 2 BULB @ 4'	⊙	110V OUTLET
	4/4 -- 4 BULB @ 4'	⊙	220V OUTLET
⊙	HANGING LIGHT FIXTURE	\$	SINGLE SWITCH
▷	TELEPHONE JACK	\$3	3-WAY SWITCH
▷	CABLE JACK	\$4	4-WAY SWITCH
⊙	KEYLESS LIGHT FIXTURE	⊙	OUTDOOR OUTLET
⊙	CEILING FAN WITH LIGHT FIXTURE	⊙	GFI
⊙	UNDER CABINET LIGHT		

DYNAMIC DESIGN GROUP, INC

David D Grorud
 (919) 601-1406
 DynamicDesignGroup@gmail.com
 www.DDGhomeplans.com

The drawings and specifications (plans) contained on these pages are the property of Dynamic Design Group and are offered to the named client or contractor for a conditional one time use. The conditional use is limited to the lot and subdivision specified herein, and only for said location. COPYRIGHT 2020

Contractor shall verify all conditions and dimensions prior to construction. Any error or omissions shall be reported to Dynamic Design Group for corrections or justification. Once construction has commenced, the contractor shall assume all responsibility. Dimensions govern over scale, code governs over dimensions.

PROJECT FOR: CAPITOL CITY HOMES
 LOCATION: MULTI
 LOT: MULTI
 SUBDIVISION: MULTI
 COUNTY: MULTI

HAVENBROOKE
 PLAN NAME
C-2190-35GL 3-25-20
 PLAN I.D. DATE

FIRST FLOOR ELECTRICAL LAYOUT

E-1
 SHEET

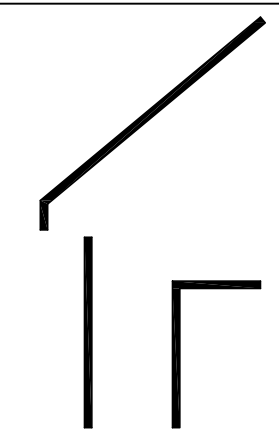

DYNAMIC DESIGN GROUP, INC

David D Grorud
(919) 601-1406
DynamicDesignGroup@gmail.com
www.DDGhomeplans.com

The drawings and specifications (plans) contained on these pages are the property of Dynamic Design Group and are offered to the named client or contractor for a conditional one time use. The conditional use is limited to the lot and subdivision specified herein, and only for said location. COPYRIGHT 2020
Contractor shall verify all conditions and dimensions prior to construction. Any error or omissions shall be reported to Dynamic Design Group for corrections or justification. Once construction has commenced, the contractor shall assume all responsibility. Dimensions govern over scale, code governs over dimensions.

CAPITOL
PROJECT FOR: CITY HOMES
LOCATION: MULTI
LOT: MULTI
SUBDIVISION: MULTI
COUNTY: MULTI

HAVENBROOKE
PLAN NAME
C-2190-35GL 3-25-20
PLAN I.D. DATE

E-1 SCR PORCH / BBQ DECK OPTIONS
SHEET

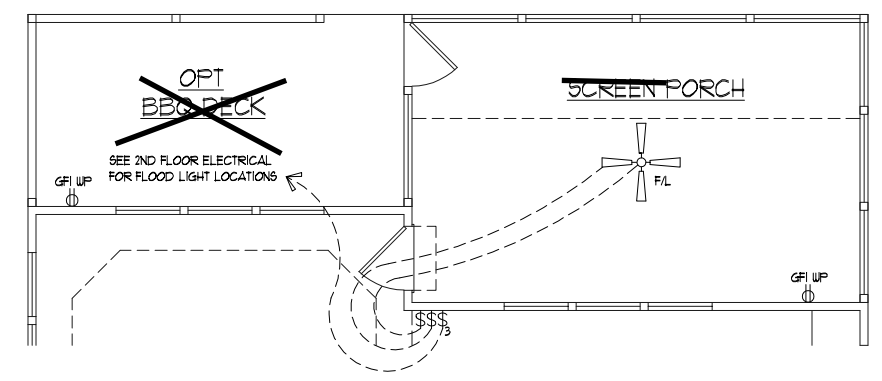

← Covered Porch

OPTIONAL
SCREEN PORCH/BBQ DECK
ELECTRICAL LAYOUT

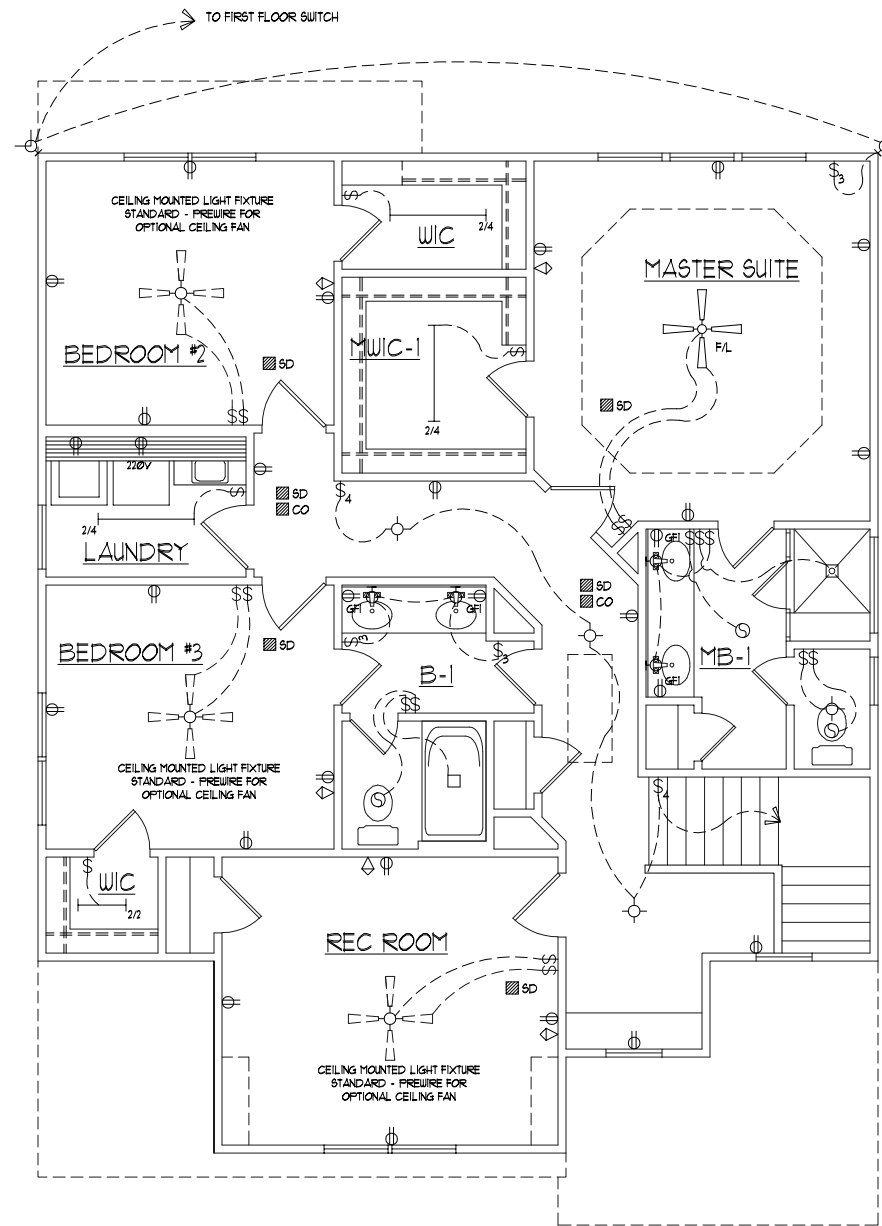

ELECTRICAL SYMBOLS		PROFESSIONAL MEMBER	
	CEILING MOUNTED LIGHT FIXTURE		
	DIRECTIONAL EYEBALL LIGHT FIXTURE		
	RECESSED LIGHT FIXTURE		EXHAUST FAN
	MINI RECESSED LIGHT FIXTURE		RECESSED SHOWER LIGHT
	WALL MOUNTED LIGHT FIXTURE		EXTERIOR FLOOD LIGHT
	FLUORESCENT LIGHT 1/2 -- 1 BULB @ 2' 2/2 -- 2 BULB @ 2' 1/4 -- 1 BULB @ 4' 2/4 -- 2 BULB @ 4' 4/4 -- 4 BULB @ 4'		SMOKE DETECTOR
	HANGING LIGHT FIXTURE		CARBON MONOXIDE DETECTOR
	TELEPHONE JACK		DOOR CHIMES
	CABLE JACK		ELECTRICAL PANEL
	KEYLESS LIGHT FIXTURE		METERBOX
	CEILING FAN WITH LIGHT FIXTURE		A/C UNIT
	UNDER CABINET LIGHT		110 OUTLET
			220V OUTLET
			SINGLE SWITCH
			3-WAY SWITCH
			4-WAY SWITCH
			OUTDOOR OUTLET
			GFI

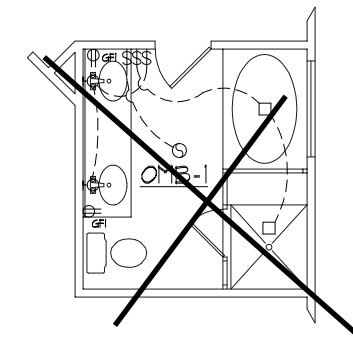

OPTIONAL MASTER BATH

ELEVATION "A"
SECOND FLOOR
WITH REC ROOM
ELECTRICAL LAYOUT

DYNAMIC DESIGN GROUP, INC

David D Grorud
(919) 601-1406
DynamicDesignGroup@gmail.com
www.DDHomeplans.com

The drawings and specifications (plans) contained on these pages are the property of Dynamic Design Group and are offered to the named client or contractor for a conditional one time use. The conditional use is limited to the lot and subdivision specified herein, and only for said location. COPYRIGHT 2020

Contractor shall verify all conditions and dimensions prior to construction. Any error or omissions shall be reported to Dynamic Design Group for corrections or justification. Once construction has commenced, the contractor shall assume all responsibility.

Dimensions govern over scale, code governs over dimensions.

CAPITOL
PROJECT FOR: CITY HOMES
LOCATION: MULTI
LOT: MULTI
SUBDIVISION: MULTI
COUNTY: MULTI

HAVENBROOKE
PLAN NAME
C-2190-35GL
PLAN I.D.
DATE
3-25-20

E-2A
SHEET

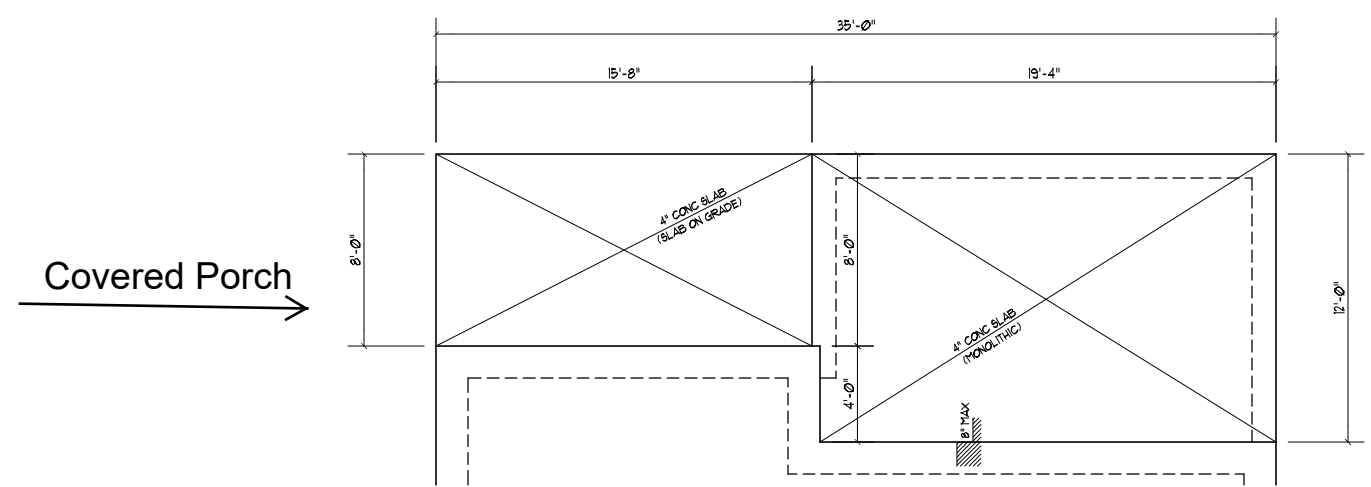

**SCREEN PORCH/BBQ DECK
WITH MONOLITHIC SLAB FOUNDATION**

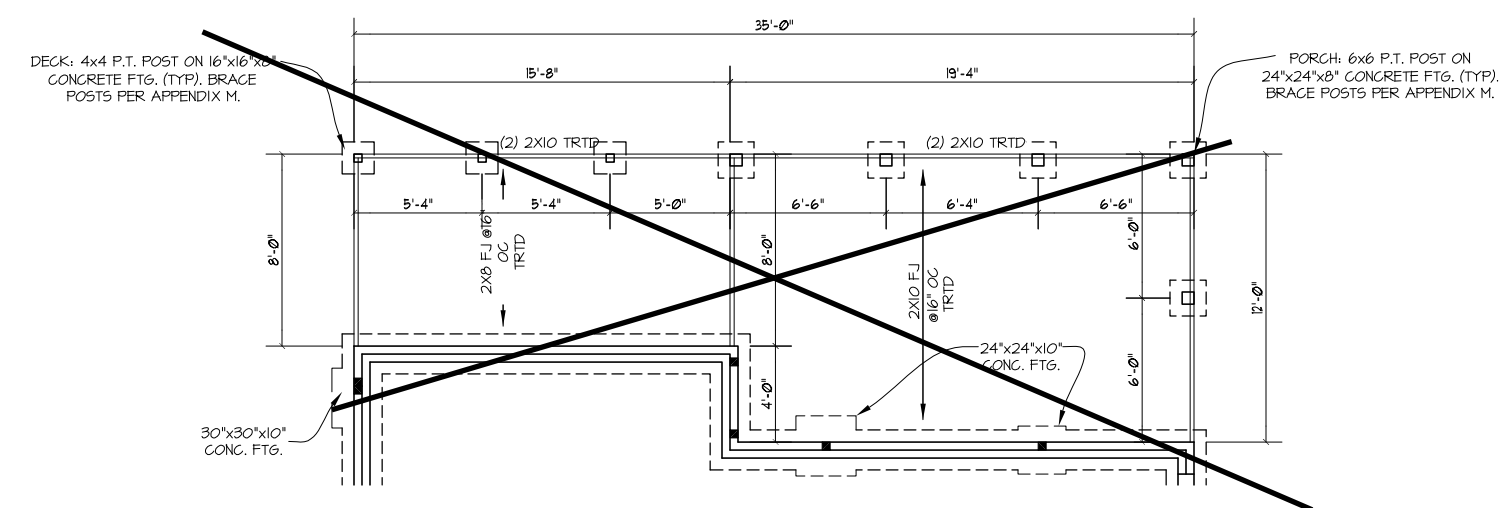

**SCREEN PORCH/BBQ DECK
WITH CRAWLSPACE FOUNDATION**

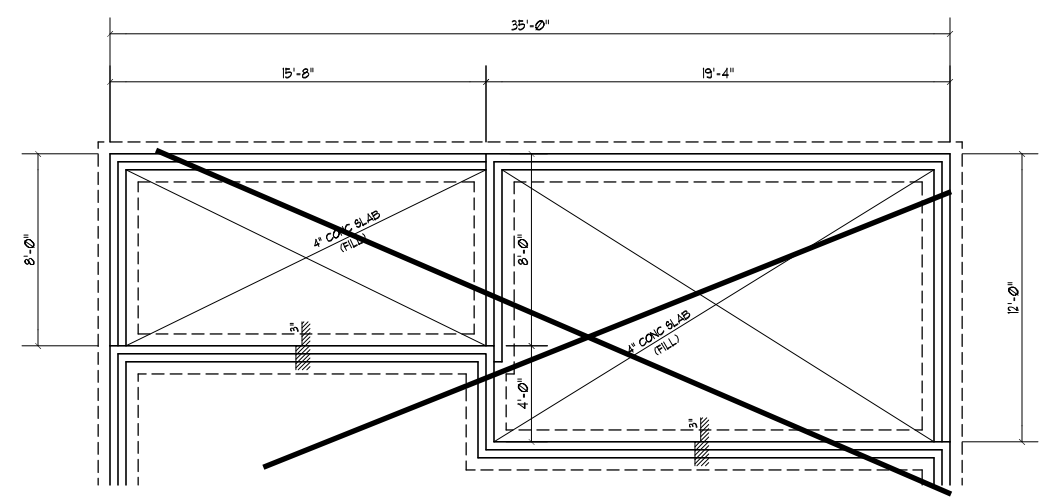

**SCREEN PORCH/BBQ DECK
WITH STEM WALL/SLAB FOUNDATION**

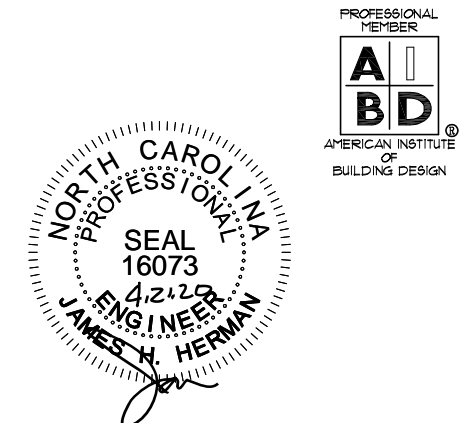

STRUCTURAL DESIGN BY:
SOUTHERN ENGINEERS, P.A.
3716 BENSON DR., RALEIGH, NC 27609
LICENSE: C-1287, PHONE: 919-878-1617
PROJECT # 16-1591-GL

Engineers seal applies only to structural components on this document. Seal does not include construction means, methods, techniques, sequences, procedures or safety precautions. Any deviations or discrepancies on plans are to be brought to the immediate attention of Southern Engineers. Failure to do so will void Southern Engineer's liability. Seal is valid for a project permitted within one year from date of seal. Use of these plans constitutes approval of terms & conditions as defined in the customer agreement.

REFER TO "SD" & "BD" SHEET(S) FOR STANDARD DETAILS, BRACING DETAILS AND STRUCTURAL NOTES.

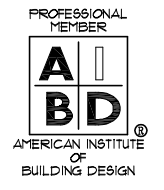

DYNAMIC DESIGN GROUP, INC

David D Grorud
(919) 601-1406
DynamicDesignGroup@gmail.com
www.DDGhomeplans.com

The drawings and specifications (plans) contained on these pages are the property of Dynamic Design Group and are offered to the named client or contractor for a conditional one time use. The conditional use is limited to the lot and subdivision specified herein, and only for said location. COPYRIGHT 2020

Contractor shall verify all conditions and dimensions prior to construction. Any error or omissions shall be reported to Dynamic Design Group for corrections or justification. Once construction has commenced, the contractor shall assume all responsibility. Dimensions govern over scale, code governs over dimensions.

CAPITOL
PROJECT FOR: CITY HOMES
LOCATION: MULTI
LOT: MULTI
SUBDIVISION: MULTI
COUNTY: MULTI

HAVENBROOKE

PLAN NAME
C-2190-35GL
PLAN I.D.

DATE
3-25-20

**SCREEN PORCH/BBQ DECK
FOUNDATION OPTIONS**
SCALE: ----- 1/8"=1'-0"

NOTES:
1) SEE SHEET D-1 FOR DETAILS.
2) DIMENSIONS ARE TO EXTERIOR OF FOUNDATION.

S-1 SCR PORCH / BBQ DECK OPTIONS SHEET

HEADER/BEAM & COLUMN NOTES

- ALL EXTERIOR AND LOAD BEARING HEADERS SHALL BE MIN. (2)2x6 (4" WALL) OR (3)2x6 (6" WALL) WITH (1) SUPPORT STUD, UNLESS NOTED OTHERWISE.
- THE NUMBER SHOWN AT BEAM AND HEADER SUPPORTS INDICATES THE NUMBER OF SUPPORT STUDS REQUIRED IN STUD POCKET OR COLUMN. THE NUMBER OF KING STUDS AT EACH END OF HEADERS IN EXTERIOR WALLS SHALL BE ACCORDING TO ITEM "d" IN TABLE R602.3(5) OR AS BELOW:
 - UP TO 4' SPAN: (1) KING STUD
 - OVER 4' UP TO 8' SPAN: (2) KING STUDS
 - OVER 8' UP TO 11' SPAN: (3) KING STUDS
 - OVER 11' SPAN: (4) KING STUDS

WHOLE HOUSE BRACING SUMMARY
 TOTAL REQUIRED BRACING: 84
 TOTAL PROVIDED BRACING: 147
 (IN FEET)

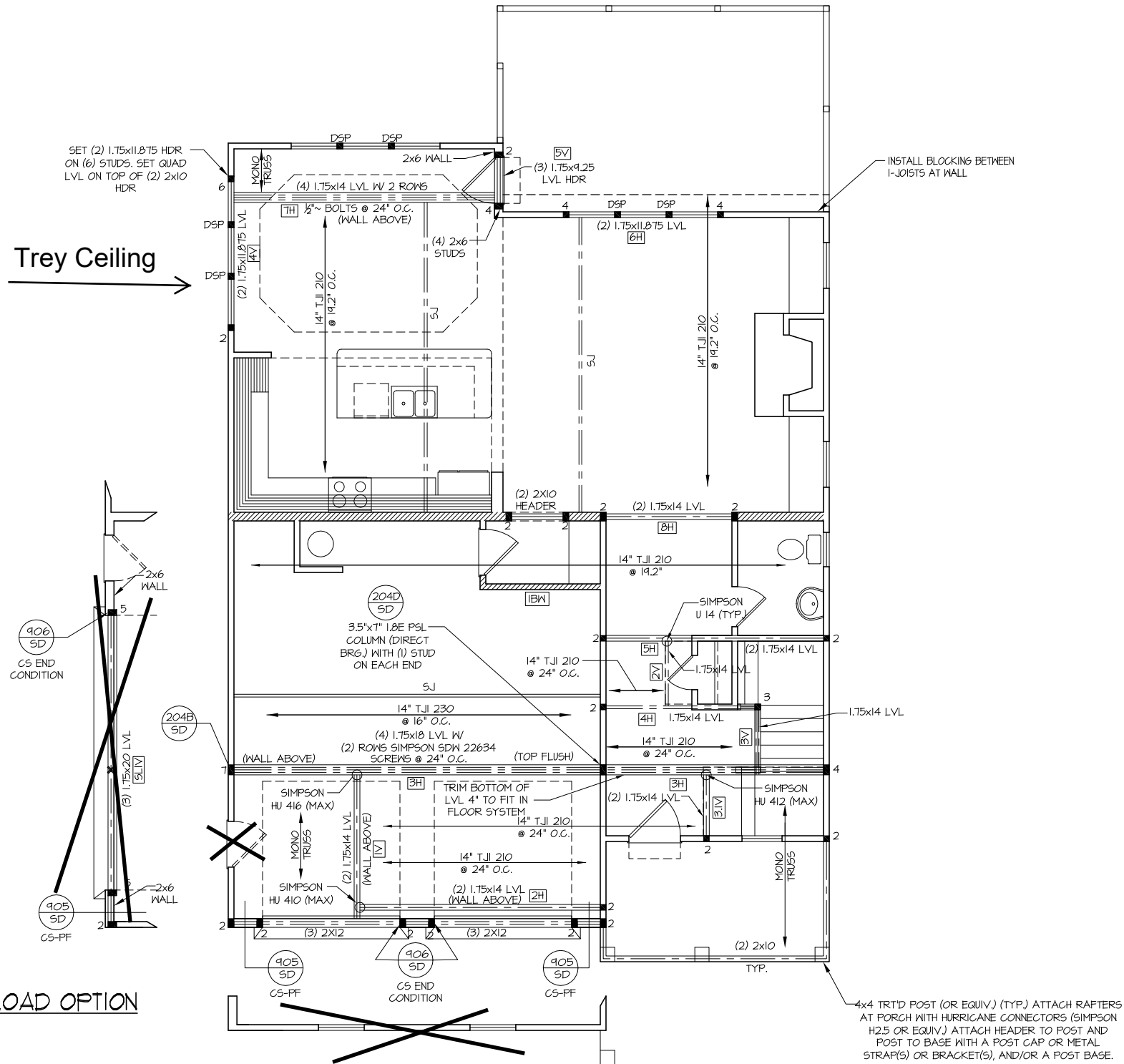

SIDE LOAD OPTION

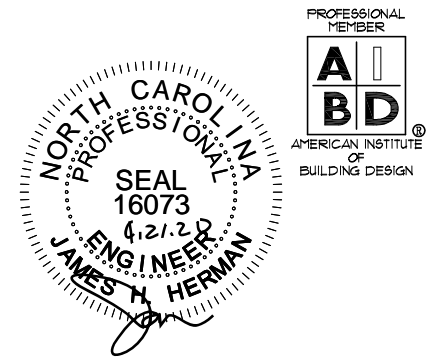

STRUCTURAL DESIGN BY:
 SOUTHERN ENGINEERS, P.A.
 3716 BENSON DR., RALEIGH, NC 27609
 LICENSE: C-1287, PHONE: 919-878-1617
 PROJECT # 16-1591-GL

Engineers seal applies only to structural components on this document. Seal does not include construction means, methods, techniques, sequences, procedures or safety precautions. Any deviations or discrepancies on plans are to be brought to the immediate attention of Southern Engineers. Failure to do so will void Southern Engineer's liability. Seal is valid for a project permitted within one year from date of seal. Use of these plans constitutes approval of terms & conditions as defined in the customer agreement.

REFER TO "SD" & "BD" SHEET(S) FOR STANDARD DETAILS, BRACING DETAILS AND STRUCTURAL NOTES.

WOOD "I" JOISTS
 (SHALL BE ONE OF THE FOLLOWING):

- TJI 210 BY I-LEVEL
- LP1 20 PLUS BY LP
- BCI 5000s I.B BY BC

ALL WOOD "I" JOISTS SHALL BE INSTALLED ACCORDING TO MANUFACTURER'S SPECIFICATIONS.

INSTALL SQUASH BLOCKS, WEB STIFFENERS, ETC. AS REQUIRED BY AND ACCORDING TO THE I-JOIST MANUFACTURER'S SPECIFICATIONS AND INSTRUCTIONS.

HANGERS FOR I-JOISTS ARE THE RESPONSIBILITY OF THE I-JOIST SUPPLIER.

LVL SCHEDULE	
2H	(2) 1.75x14 LVL - 16'
3H	(4) 1.75x18 LVL - 36'
4H	(1) 1.75x14 LVL - 10'
5H	(2) 1.75x14 LVL - 14'
6H	(2) 1.75x11.875 LVL - 10'
7H	(4) 1.75x14 LVL - 16'
8H	(2) 1.75x14 LVL - 8'
IV	(2) 1.75x14 LVL - 10'
2V	(1) 1.75x14 LVL - 4'
3V	(1) 1.75x14 LVL - 4'
3IV	(2) 1.75x14 LVL - 4'
4V	(2) 1.75x11.875 LVL - 10'
5V	(3) 1.75x9.25 LVL - 6'

REFER TO "SD" & "BD" SHEET(S) FOR STANDARD DETAILS, BRACING DETAILS AND STRUCTURAL NOTES.

LVL SCHEDULE	
SIDE LOAD OPTION	
(3)	1.75x20 LVL - 20'-0" SLIV

**ELEVATION "A"
 FIRST FLOOR CEILING /
 STRUCTURAL PLAN**

SCALE: 1/8" = 1'-0"

NOTES:

- SHADED WALLS DENOTE LOAD BEARING WALLS.
- DENOTES SOLID STUDS.

DYNAMIC DESIGN GROUP, INC
 David D Groner
 (919) 601-1406
 DynamicDesignGroup@gmail.com
 www.DDGhomeplans.com

The drawings and specifications (plans) contained on these pages are the property of Dynamic Design Group and are offered to the named client or contractor for a conditional one time use. The conditional use is limited to the lot and subdivision specified herein, and only for said location. COPYRIGHT 2020
 Contractor shall verify all conditions and dimensions prior to construction. Any error or omissions shall be reported to Dynamic Design Group for corrections or justification. Once construction has commenced, the contractor shall assume all responsibility. Dimensions govern over scale, code governs over dimensions.

CAPITOL CITY HOMES
 PROJECT FOR:
 LOCATION: MULTI
 LOT: MULTI
 SUBDIVISION: MULTI
 COUNTY: MULTI

HAVENBROOKE
 PLAN NAME
C-2190-35GL
 PLAN I.D.
3-25-20
 DATE

S-2A
 SHEET

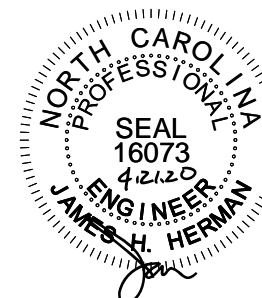

STRUCTURAL DESIGN BY:
SOUTHERN ENGINEERS, P.A.
3716 BENSON DR., RALEIGH, NC 27609
LICENSE: C-1287, PHONE: 919-878-1617
PROJECT # 16-1591-GL

- Engineers seal applies only to structural components on this document. Seal does not include construction means, methods, techniques, sequences, procedures or safety precautions.
- Any deviations or discrepancies on plans are to be brought to the immediate attention of Southern Engineers. Failure to do so will void Southern Engineer's liability.
- Seal is valid for a project permitted within one year from date of seal.
- Use of these plans constitutes approval of terms & conditions as defined in the customer agreement.

REFER TO "SD" & "BD" SHEET(S) FOR STANDARD DETAILS, BRACING DETAILS AND STRUCTURAL NOTES.

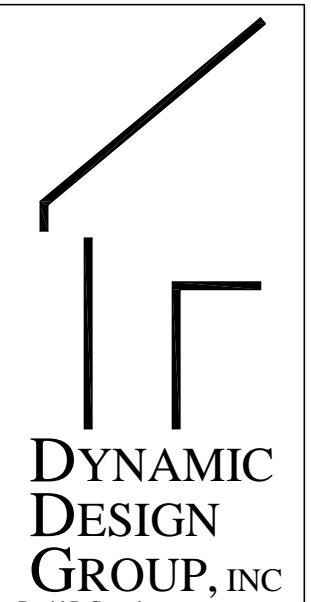

David D Grorud
(919) 601-1406
DynamicDesignGroup@gmail.com
www.DDGhomeplans.com

The drawings and specifications (plans) contained on these pages are the property of Dynamic Design Group and are offered to the named client or contractor for a conditional one time use. The conditional use is limited to the lot and subdivision specified herein, and only for said location. COPYRIGHT 2020

Contractor shall verify all conditions and dimensions prior to construction. Any error or omissions shall be reported to Dynamic Design Group for corrections or justification. Once construction has commenced, the contractor shall assume all responsibility. Dimensions govern over scale, code governs over dimensions.

CAPITOL
PROJECT FOR: CITY HOMES
LOCATION: MULTI
LOT: MULTI
SUBDIVISION: MULTI
COUNTY: MULTI

HAVENBROOKE
PLAN NAME
C-2190-35GL
PLAN I.D.
3-25-20
DATE

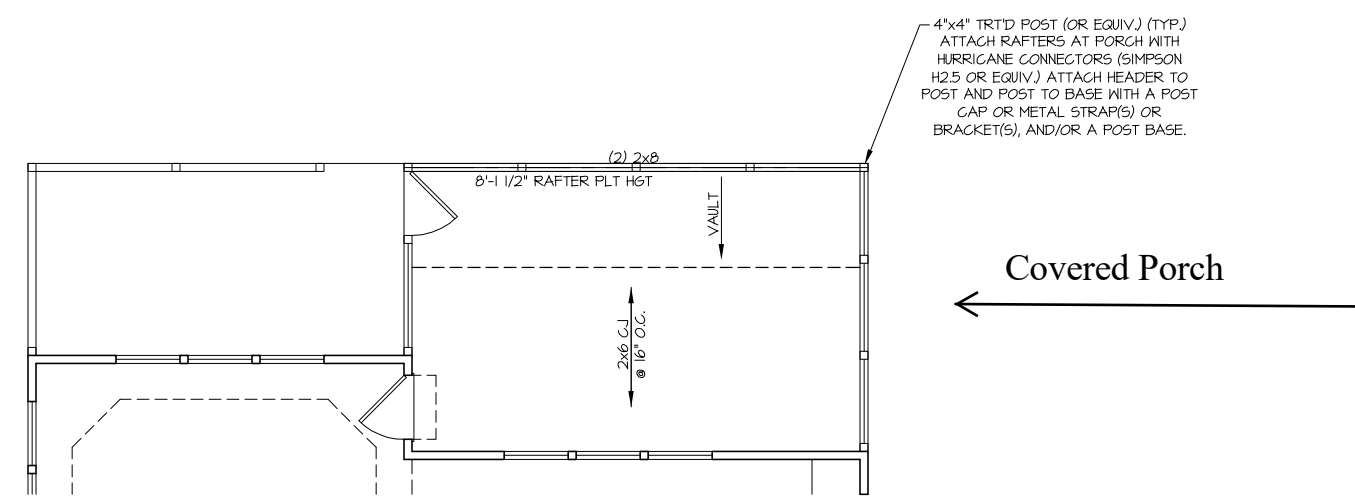

SCREEN PORCH
CEILING / STRUCTURAL PLAN
SCALE: 1/8" = 1'-0"

- NOTES:
- 1) SHADED WALLS DENOTE LOAD BEARING WALLS.
 - 2) ■ DENOTES SOLID STUDS.

S-2 SCR PORCH
OPTION
SHEET

HEADER/BEAM & COLUMN NOTES

- ALL EXTERIOR AND LOAD BEARING HEADERS SHALL BE MIN. (2)2x6 (4" WALL) OR (3)2x6 (6" WALL) WITH (1) SUPPORT STUD, UNLESS NOTED OTHERWISE.
- THE NUMBER SHOWN AT BEAM AND HEADER SUPPORTS INDICATES THE NUMBER OF SUPPORT STUDS REQUIRED IN STUD POCKET OR COLUMN. THE NUMBER OF KING STUDS AT EACH END OF HEADERS IN EXTERIOR WALLS SHALL BE ACCORDING TO ITEM "d" IN TABLE R602.3(5) OR AS BELOW:
 - UP TO 4' SPAN: (1) KING STUD
 - OVER 4' UP TO 8' SPAN: (2) KING STUDS
 - OVER 8' UP TO 11' SPAN: (3) KING STUDS
 - OVER 11' SPAN: (4) KING STUDS

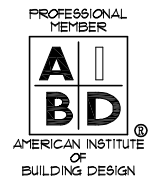
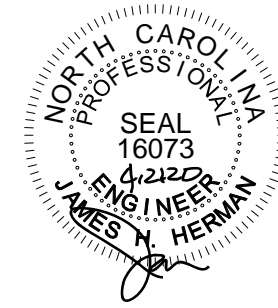

STRUCTURAL DESIGN BY:
SOUTHERN ENGINEERS, P.A.
3716 BENSON DR., RALEIGH, NC 27609
LICENSE: C-1287, PHONE: 919-878-1617
PROJECT # 16-1591-GL

- Engineer's seal applies only to structural components on this document. Seal does not include construction means, methods, techniques, sequences, procedures or safety precautions.
- Any deviations or discrepancies on plans are to be brought to the immediate attention of Southern Engineers. Failure to do so will void Southern Engineer's liability.
- Seal is valid for a project permitted within one year from date of seal.
- Use of these plans constitutes approval of terms & conditions as defined in the customer agreement.

REFER TO "SD" & "BD" SHEET(S) FOR STANDARD DETAILS, BRACING DETAILS AND STRUCTURAL NOTES.

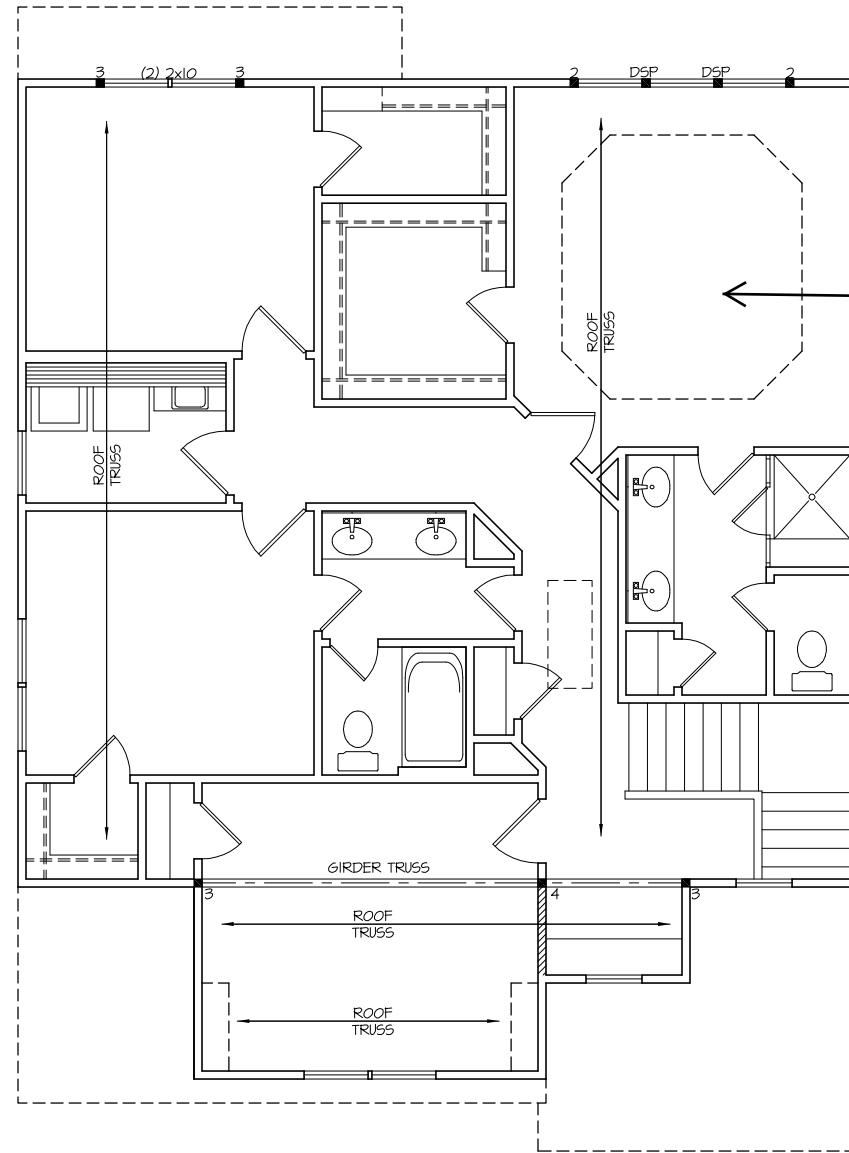

Trey Ceiling

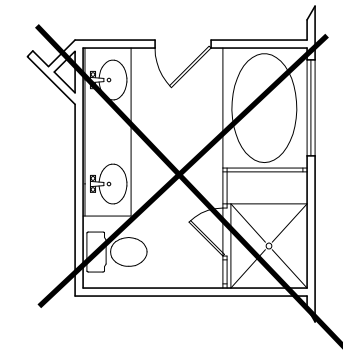

ELEVATION "A"
WITH REC ROOM
SECOND FLOOR CEILING /
STRUCTURAL PLAN

SCALE: 1/8" = 1'-0"

NOTES:

- SHADED WALLS DENOTE LOAD BEARING WALLS.
- DENOTES SOLID STUDS.

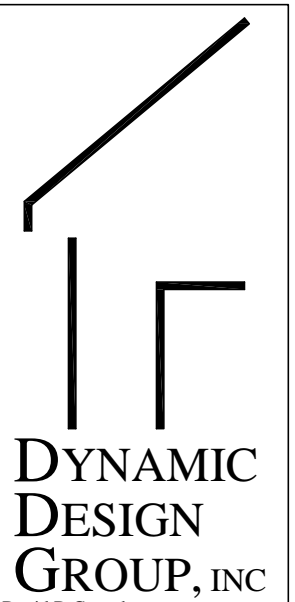

David D Gronud
(919) 601-1406
DynamicDesignGroup@gmail.com
www.DDGhomeplans.com

The drawings and specifications (plans) contained on these pages are the property of Dynamic Design Group and are offered to the named client or contractor for a conditional one time use. The conditional use is limited to the lot and subdivision specified herein, and only for said location. COPYRIGHT 2020
Contractor shall verify all conditions and dimensions prior to construction. Any error or omissions shall be reported to Dynamic Design Group for corrections or justification. Once construction has commenced, the contractor shall assume all responsibility. Dimensions govern over scale, code governs over dimensions.

CAPITOL
PROJECT FOR: CITY HOMES
LOCATION: MULTI
LOT: MULTI
SUBDIVISION: MULTI
COUNTY: MULTI

HAVENBROOKE
PLAN NAME
C-2190-35GL
PLAN I.D.
3-25-20
DATE

S-3A
SHEET

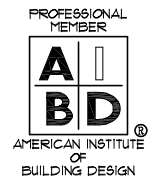
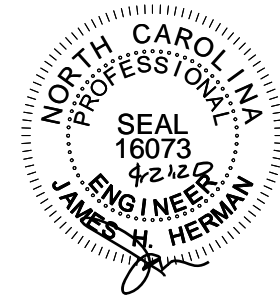

STRUCTURAL DESIGN BY:
 SOUTHERN ENGINEERS, P.A.
 3716 BENSON DR., RALEIGH, NC 27609
 LICENSE: C-1287, PHONE: 919-878-1617
 PROJECT # 16-1591-GL

Engineers seal applies only to structural components on this document. Seal does not include construction means, methods, techniques, sequences, procedures or safety precautions. Any deviations or discrepancies on plans are to be brought to the immediate attention of Southern Engineers. Failure to do so will void Southern Engineer's liability. Seal is valid for a project permitted within one year from date of seal. Use of these plans constitutes approval of terms & conditions as defined in the customer agreement.

REFER TO "SD" & "BD" SHEET(S) FOR STANDARD DETAILS, BRACING DETAILS AND STRUCTURAL NOTES.

TRUSS SYSTEM REQUIREMENTS
 NC (2018 NCRC): Wind: 115-120 mph

- TRUSS SYSTEM LAYOUTS (PLACEMENT PLANS) SHALL BE DESIGNED IN ACCORDANCE WITH SEALED STRUCTURAL PLANS. ANY NEED TO CHANGE TRUSSES SHALL BE COORDINATED WITH SOUTHERN ENGINEERS.
- TRUSS SCHEMATICS (PROFILES) SHALL BE PREPARED AND SEALED BY TRUSS MANUFACTURER.
- ALL TRUSSES SHALL BE DESIGNED FOR BEARING ON SFF #2 OR #3 PLATES OR LEDGERS (UNO).
- ALL REQUIRED ANCHORS FOR TRUSSES DUE TO UPLIFT OR BEARING SHALL MEET THE REQUIREMENTS AS SPECIFIED ON THE TRUSS SCHEMATICS.

DYNAMIC DESIGN GROUP, INC

David D Gronid
 (919) 601-1406
 DynamicDesignGroup@gmail.com
 www.DDGHomeplans.com

The drawings and specifications (plans) contained on these pages are the property of Dynamic Design Group and are offered to the named client or contractor for a conditional one time use. The conditional use is limited to the lot and subdivision specified herein, and only for said location. COPYRIGHT 2020

Contractor shall verify all conditions and dimensions prior to construction. Any error or omissions shall be reported to Dynamic Design Group for corrections or justification. Once construction has commenced, the contractor shall assume all responsibility. Dimensions govern over scale, code governs over dimensions.

CAPITOL
 PROJECT FOR: CITY HOMES
 LOCATION: MULTI
 LOT: MULTI
 SUBDIVISION: MULTI
 COUNTY: MULTI

HAVENBROOKE

PLAN NAME
C-2190-35GL
 PLAN I.D.

DATE
3-25-20

S-4A
 SHEET

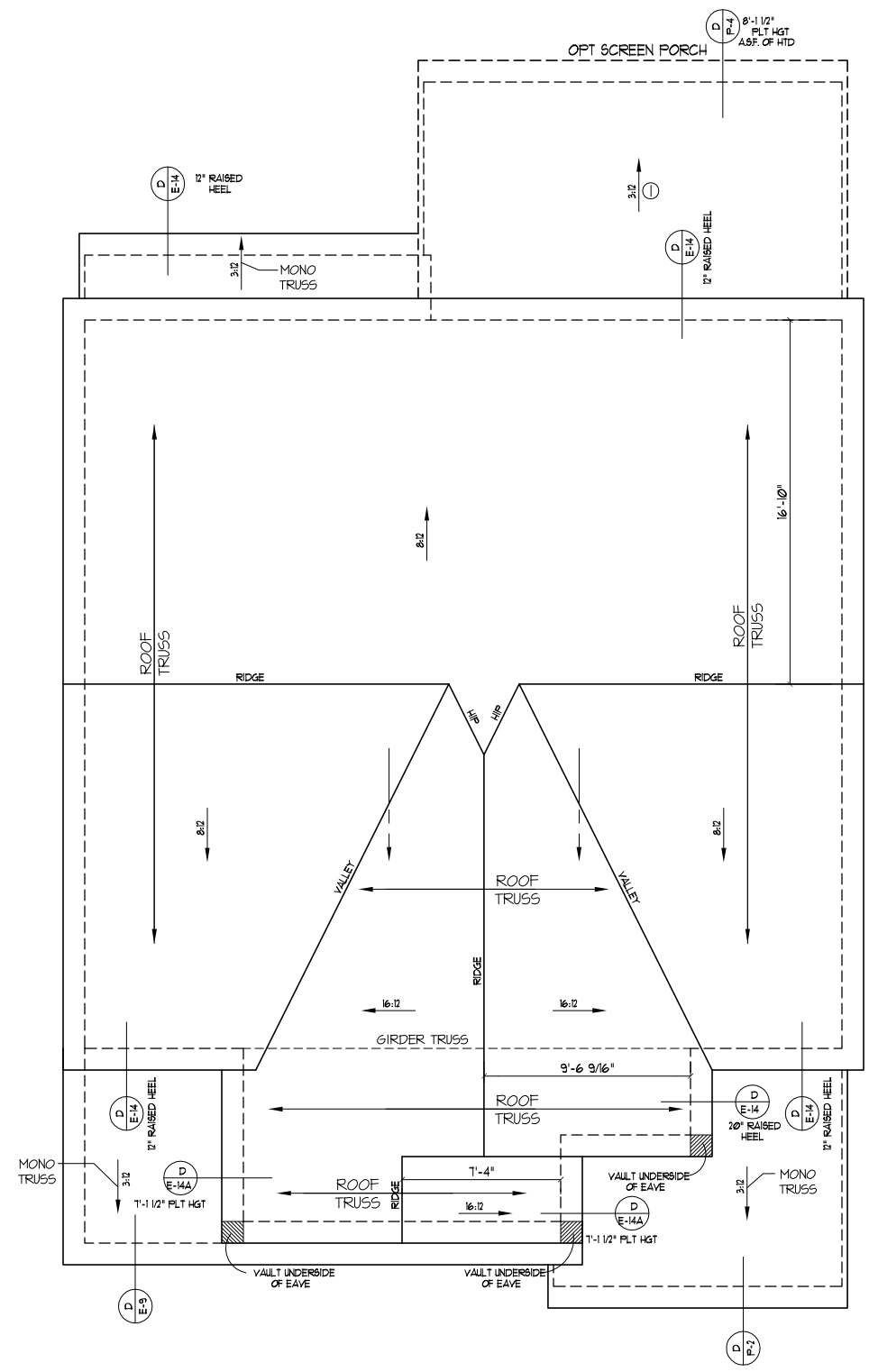

ELEVATION "A"
ROOF FRAMING PLAN
 SCALE -----1/8"=1'-0"

- NOTES:
- SEE SHEET D-1 FOR DETAILS.
 - DIMENSIONS ARE FROM EXT. OF FRAMING TO CENTER LINE OF RIDGE.

ATTIC VENTILATION			
REQUIRED	1780	SQ. FT. OF ATTIC / 300 =	5.93
		SQ. FT. OF INLET & OUTLET	
PROVIDED (INLET) SOFFIT	07	SQ. FT. PER X	64
		LINEAR FT. OF VENT.	4.48
		SQ. FT. OF VENT.	(TOTAL OF INLET)
			46 %
(OUTLET) RIDGE	11	SQ. FT. PER X	48
		LINEAR FT. OF VENT.	5.28
		SQ. FT. OF VENT.	(TOTAL OF OUTLET)
			54 %
			9.76
		TOTAL SQ. FT. OF VENT.	

STRUCTURAL NOTES

NC (2018 NCR): Wind: 115-120 mph

- ENGINEER'S SEAL APPLIES ONLY TO STRUCTURAL COMPONENTS INCLUDING ROOF RAFTERS, HIPs, VALLEYS, RIDGES, FLOORS, WALLS, BEAMS AND HEADERS, COLUMNS, CANTILEVERS, OFFSET LOAD BEARING WALLS, PIER & GIRDER SYSTEM, FOOTINGS, AND PILING SYSTEM. ENGINEER'S SEAL DOES NOT CERTIFY DIMENSIONAL ACCURACY OR ARCHITECTURAL LAYOUT INCLUDING ROOF SYSTEM. ALL REQUIREMENTS FOR PROFESSIONAL CERTIFICATION SHALL BE PROVIDED BY THE APPROPRIATE PROFESSIONAL. SOUTHERN ENGINEERS, P.A. CERTIFIES ONLY THE STRUCTURAL COMPONENTS AS SPECIFICALLY STATED.
- ALL CONSTRUCTION SHALL CONFORM TO THE LATEST REQUIREMENTS OF RESIDENTIAL CODE, PLUS ALL LOCAL CODES AND REGULATIONS. THE STRUCTURAL ENGINEER IS NOT RESPONSIBLE FOR, AND WILL NOT HAVE CONTROL OF, CONSTRUCTION MEANS, METHODS, TECHNIQUES, SEQUENCES OR PROCEDURES, OR FOR SAFETY PRECAUTIONS AND PROGRAMS IN CONNECTION WITH THE CONSTRUCTION WORK, NOR WILL THE ENGINEER BE RESPONSIBLE FOR THE CONTRACTOR'S FAILURE TO CARRY OUT THE CONSTRUCTION WORK IN ACCORDANCE WITH THE CONTRACT DOCUMENTS. "CONSTRUCTION REVIEW" SERVICES ARE NOT PART OF OUR CONTRACT. ALL MEMBERS SHALL BE FRAMED ANCHORED, TIED AND BRACED IN ACCORDANCE WITH GOOD CONSTRUCTION PRACTICE AND THE BUILDING CODE.
- DESIGN LOADS (LISTED AS: LIVE LOAD, DEAD LOAD, DEFLECTION)
 - ROOMS OTHER THAN SLEEPING ROOMS: (40 PSF, 10 PSF, L/360)
 - SLEEPING ROOMS: (30 PSF, 10 PSF, L/360)
 - ATTIC WITH PERMANENT STAIR: (40 PSF, 10 PSF, L/360)
 - ATTIC WITHOUT PERMANENT STAIR: (20 PSF, 10 PSF, L/360)
 - ATTIC WITHOUT STORAGE: (10 PSF, 10 PSF, L/240)
 - STAIRS: (40 PSF, 10 PSF, L/360)
 - EXTERIOR BALCONIES: (60 PSF, 10 PSF, L/360)
 - DECKS: (40 PSF, 10 PSF, L/360)
 - GUARDRAILS AND HANDRAILS: (200 LBS)
 - PASSENGER VEHICLE GARAGES: (50 PSF, 10 PSF, L/360)
 - FIRE ESCAPES: (40 PSF, 10 PSF, L/360)
 - SNOW: (20 PSF)
- WALLS SHALL BE BRACED BY SHEATHING WALLS ON ALL STORIES WITH WOOD STRUCTURAL PANELS. SEE FRAMING NOTES FOR THICKNESS AND NAILING REQUIREMENTS.
- SEE APPENDIX M (DCA6) FOR EXTERIOR DECK REQUIREMENTS INCLUDING ATTACHMENTS FOR LATERAL LOADS.
- CONCRETE SHALL HAVE A MINIMUM 28 DAY STRENGTH OF 3000 PSI AND A MAXIMUM SLUMP OF 5 INCHES UNLESS NOTED OTHERWISE (UNO). AIR ENTRAINED PER TABLE 402.2. ALL CONCRETE SHALL BE PROPORTIONED, MIXED, HANDLED, SAMPLED, TESTED, AND PLACED IN ACCORDANCE WITH ACI STANDARDS. ALL SAMPLES FOR PUMPING SHALL BE TAKEN FROM THE EXIT END OF THE PUMP. CONTROL JOINTS IN SLABS SHALL BE SPACED ON A GRID OF +30 TIMES THE DEPTH (D). CONTROL JOINTS SHALL BE SAWCUT TO A DEPTH OF 1/D. (I.E. 4" CONCRETE SLABS SHALL HAVE 1/4" DEEP CONTROL JOINTS SAWCUT IN SLAB ON A +10'-0" x +10'-0" GRID).
- ALLOWABLE SOIL BEARING PRESSURE ASSUMED TO BE 2000 PSF. THE CONTRACTOR MUST CONTACT A GEOTECHNICAL ENGINEER AND THE STRUCTURAL ENGINEER IF UNSATISFACTORY SUBSURFACE CONDITIONS ARE ENCOUNTERED. THE SURFACE AREA ADJACENT TO THE FOUNDATION WALL SHALL BE PROVIDED WITH ADEQUATE DRAINAGE, AND SHALL BE GRADED SO AS TO DRAIN SURFACE WATER AWAY FROM FOUNDATION WALLS.
- ALL FRAMING LUMBER SHALL BE SPF #2 (Fb = 875 PSI) UNLESS NOTED OTHERWISE (UNO). ALL TREATED LUMBER SHALL BE SYP #2. PLATE MATERIAL MAY BE SPF #3 OR SYP #3 (Fc(perp) = 425 PSI - MIN).
- L.V.L. SHALL BE LAMINATED VENEER LUMBER: Fb=2600 PSI, Fv=285 PSI, E=1.9x10⁶ PSI.
 - P.S.L. SHALL BE PARALLEL STRAND LUMBER: Fb=2400 PSI, Fv=240 PSI, E=2.0x10⁶ PSI.
 - L.S.L. SHALL BE LAMINATED STRAND LUMBER: Fb=2250 PSI, Fv=400 PSI, E=1.55x10⁶ PSI. INSTALL ALL CONNECTIONS PER MANUFACTURERS INSTRUCTIONS.
- ALL ROOF TRUSS AND I-JOIST LAYOUTS SHALL BE PREPARED IN ACCORDANCE WITH THE SEALED STRUCTURAL DRAWINGS. TRUSSES AND I-JOISTS SHALL BE INSTALLED ACCORDING TO THE MANUFACTURER'S SPECIFICATIONS. ANY CHANGE IN TRUSS OR I-JOIST LAYOUT SHALL BE COORDINATED WITH SOUTHERN ENGINEERS.
- ALL STRUCTURAL STEEL SHALL BE ASTM A-36. STEEL BEAMS SHALL BE SUPPORTED AT EACH END WITH A MINIMUM BEARING LENGTH OF 3 1/2" INCHES AND FULL FLANGE WIDTH. PROVIDE SOLID BEARING FROM BEAM SUPPORT TO FOUNDATION. BEAMS SHALL BE ATTACHED TO EACH SUPPORT WITH TWO LAG SCREWS (1/2" DIAMETER x 4" LONG). LATERAL SUPPORT IS CONSIDERED ADEQUATE PROVIDING THE JOIST ARE TOE NAILED TO THE SOLE PLATE, AND SOLE PLATE IS NAILED OR BOLTED TO THE BEAM FLANGE @ 48" O.C. ALL STEEL TUBING SHALL BE ASTM A500. LAP ALL REBAR SPLICES 30 BAR DIAMETERS.
- REBAR SHALL BE DEFORMED STEEL, ASTM615, GRADE 60.
- FLITCH BEAMS SHALL BE BOLTED TOGETHER USING (2) ROWS OF 1/2" DIAMETER BOLTS (ASTM A325) WITH WASHERS PLACED UNDER THE THREADED END OF BOLT. BOLTS SHALL BE SPACED AT 24" O.C. (MAX), AND STAGGERED AT THE TOP AND BOTTOM OF BEAM (2" EDGE DISTANCE), WITH 2 BOLTS LOCATED AT 6" FROM EACH END.
- BRICK LINTELS (WHEN REQUIRED) SHALL BE 3 1/2"x3 1/2"x1/4" STEEL ANGLE FOR UP TO 6'-0" SPAN AND 6"x4"x5/16" STEEL ANGLE WITH 6" LEG VERTICAL FOR SPANS UP TO 9'-0". SEE PLANS FOR SPANS OVER 9'-0". SEE ALSO SECTION R103.7.3 LINTELS.

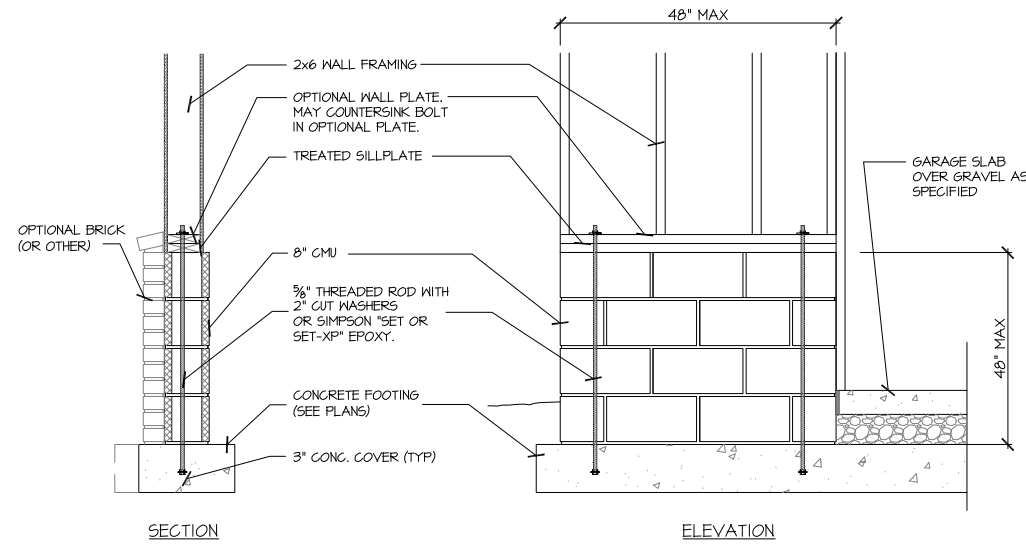

907 SD GARAGE 'WING WALL' REINFORCING PER IRC FIGURE R602.10.4.3

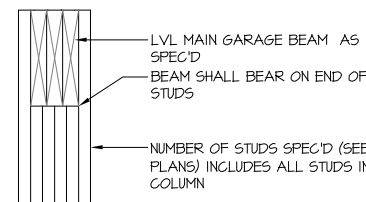

204B SD TYP. GARAGE BEAM BEARING NTS

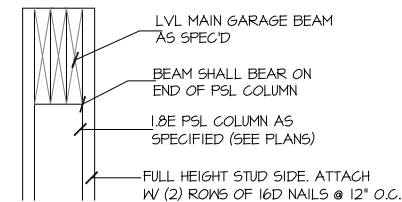

204D SD TYP. GARAGE BEAM BEARING NTS

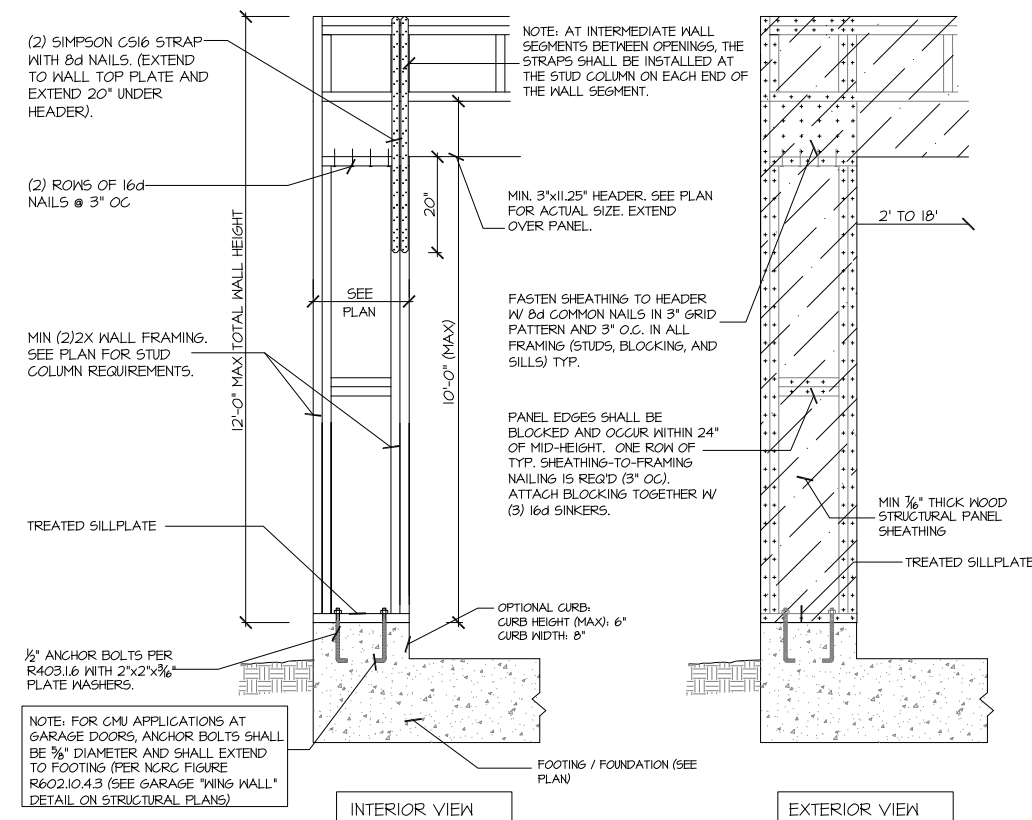

905B SD CS-PF: CONTINUOUS PORTAL FRAME CONSTRUCTION DETAIL AND APPLICATION BASED ON NCR FIGURE R602.10.1 - PORTAL FRAME CONSTRUCTION

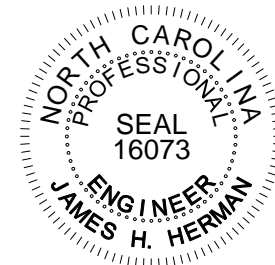

STRUCTURAL DESIGN BY:
SOUTHERN ENGINEERS, P.A.
3716 BENSON DR. RALEIGH, NC 27609
LICENSE: C-1287, PHONE: 919-878-1617
PROJECT # 16-1591-GL



- Engineers seal applies only to structural components on this document. Seal does not include construction means, methods, techniques, sequences, procedures or safety precautions.
- Any deviations or discrepancies on plans are to be brought to the immediate attention of Southern Engineers. Failure to do so will void Southern Engineer's liability.
- Seal is valid for a project permitted within one year from date of seal.
- Use of these plans constitutes approval of terms & conditions as defined in the customer agreement.

FRAMING NOTES

NC (2018 NCR): Wind: 115-120 mph

- BRACING METHOD AND TYPE: CONTINUOUSLY SHEATHED WSP: CS-WSP. NOTE THAT THE WALL BRACING AMOUNT PROVIDED ON THE PLANS (DETAILS AND SPECIFICATIONS) IS GREATER THAN THE AMOUNT OF WALL BRACING REQUIRED BY SECTION R602.10 OF THE CODE. SEE NOTES BELOW FOR DETAILS AND SPECIFICATIONS FOR WALL BRACING AND WALL FRAMING.
- EXTERIOR WALL SHEATHING: WALLS SHALL BE BRACED BY SHEATHING WALLS ON ALL STORIES WITH WOOD STRUCTURAL PANEL SHEATHING (WSP) (EXPOSURE B: 7/16", EXPOSURE C: 15/32"). SHEATHING SHALL BE ATTACHED WITH 8d NAILS AT A 6 1/2" NAILING PATTERN (6" OC AT PANEL EDGES AND 12" OC AT INTERMEDIATE SUPPORTS). INSTALL BLOCKING AT ALL PANEL EDGES.
- WSP SHEATHING SHALL EXTEND TO THE UPPERMOST DOUBLE BEARING PLATE BLOCK AT ROOF PER SECTION R602.10.4.5 AND ATTACH BRACED WALLS PER CODE. WSP SHEATHING BETWEEN FLOORS SHALL BE SPLICED ALONG CONTINUOUS BAND OR THE WSP SHEATHING MAY BE SPLICED ACROSS STUDS (CONTINUOUS ACROSS FLOOR SYSTEM) WITH BLOCKING AT PANEL EDGES. (MINIMUM 12" BEYOND FLOOR BREAK) OR OTHER APPROVED METHOD.
- "HD" = HOLD-DOWN: HOLD-DOWN DEVICE (NOTED AS "HD" ON PLANS) SHALL BE AN 800 POUND CAPACITY ASSEMBLY AS NOTED ON PLANS. SEE DETAILS FOR HD ASSEMBLY.
 - **GROUND/FIRST FLOOR: USE "HD HOLD-DOWN DETAIL" ON SD SHEET (OR EQUIV.)
 - **UPPER FLOORS: ATTACH BASE OF KING STUD WITH A SIMPSON CS22 STRAP DOWN ACROSS THE BAND AND DOWN TO A STUD BELOW OR HEADER BELOW. EXTEND STRAP 1" MIN ALONG EACH STUD (OR HEADER) AND ATTACH EACH END W/ (1) 8d NAIL.
- INTERIOR BRACED WALL: (NOTED AS "IBW" ON PLANS) ATTACH 1/2" GYPSUM BOARD (GB) ON EACH SIDE OF WALL WITH A MIN. OF 5d COOLER NAILS OR #6 SCREWS @ 1" O.C. ALONG THE EDGES AND AT INTERMEDIATE SUPPORTS.
- INTERIOR BRACED WALL-WOOD STRUCTURAL PANEL: (NOTED AS "IBW-WSP" ON PLANS). ATTACH ONE SIDE WITH 7/16" WSP SHEATHING WITH 8d NAILS AT A 6 1/2" NAILING PATTERN (6" OC AT PANEL EDGES AND 12" OC AT INTERMEDIATE SUPPORTS). INSTALL BLOCKING AT ALL PANEL EDGES. ATTACH GB OVER WSP AS REQUIRED. ATTACH OPPOSITE SIDE WITH 1/2" GB WITH A MIN. OF 5d COOLER NAILS OR #6 SCREWS @ 1" O.C. ALONG THE EDGES AND AT INTERMEDIATE SUPPORTS.

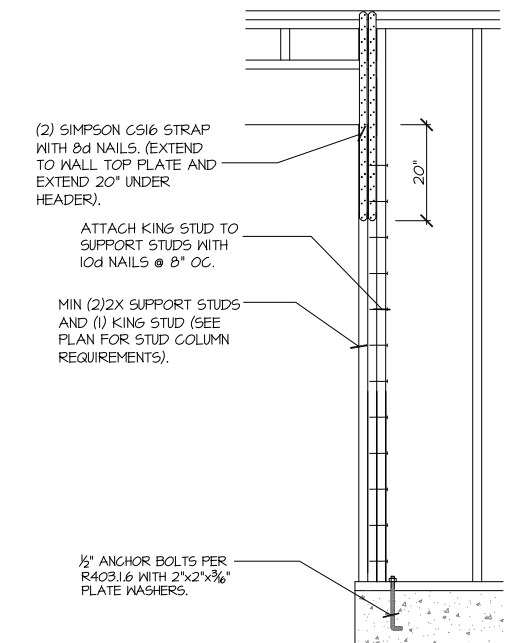

906 SD CS-PF: END CONDITION DETAIL (FOR USE WITH SINGLE CS-PF CONDITION) DETAIL AND APPLICATION BASED ON NCR FIGURE R602.10.1 - PORTAL FRAME CONSTRUCTION

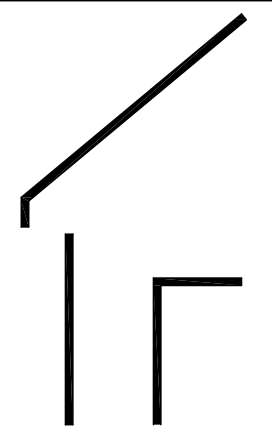

DYNAMIC DESIGN GROUP, INC

David D Grorud
(919) 601-1406
DynamicDesignGroup@gmail.com

The drawings and specifications (plans) contained on these pages are the property of Dynamic Design Group and are offered to the named client or contractor for a conditional one time use. The conditional use is limited to the lot and subdivision specified herein, and only for said location. COPYRIGHT 2020
Contractor shall verify all conditions and dimensions prior to construction. Any error or omissions shall be reported to Dynamic Design Group for corrections or justification. Once construction has commenced, the contractor shall assume all responsibility. Dimensions govern over scale, code governs over dimensions.

CAPITOL PROJECT FOR: CITY HOMES
LOCATION: MULTI
LOT: MULTI
SUBDIVISION: MULTI
COUNTY: MULTI

HAVENBROOKE
PLAN NAME
C-2190-35GL
PLAN I.D.
3-25-20
DATE

SD SHEET

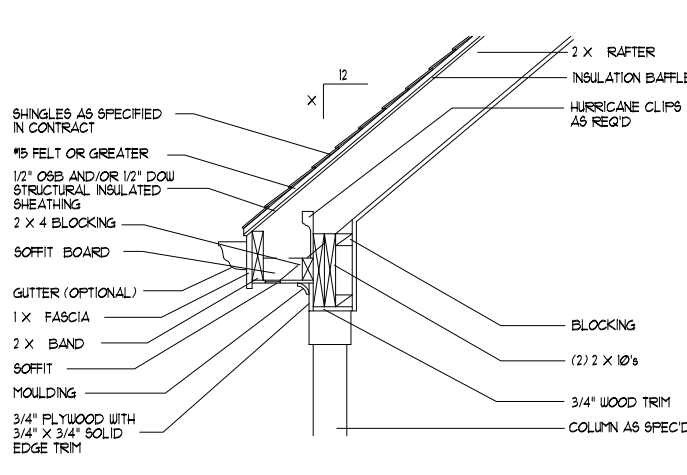

D
P-4 (NTS)

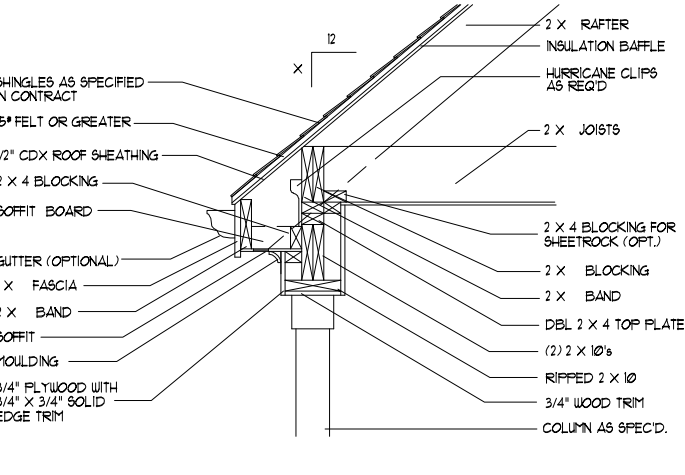

D
P-2 (NTS)

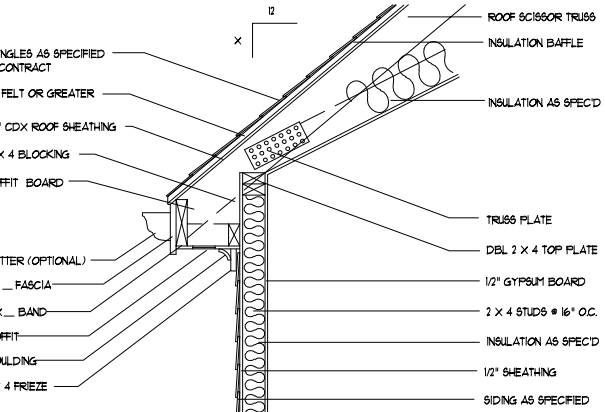

D
E-14A (NTS)

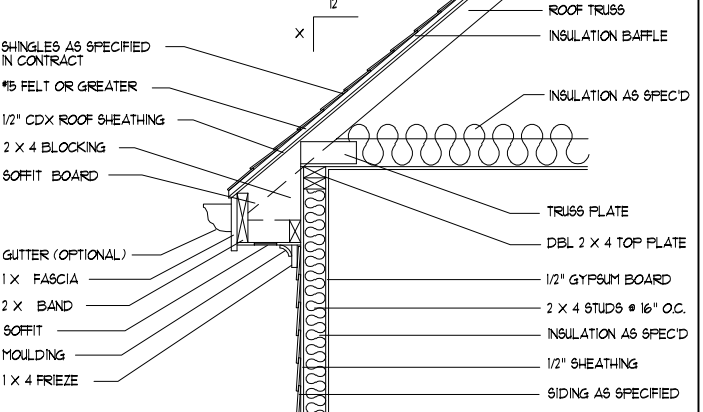

D
E-14 (NTS)

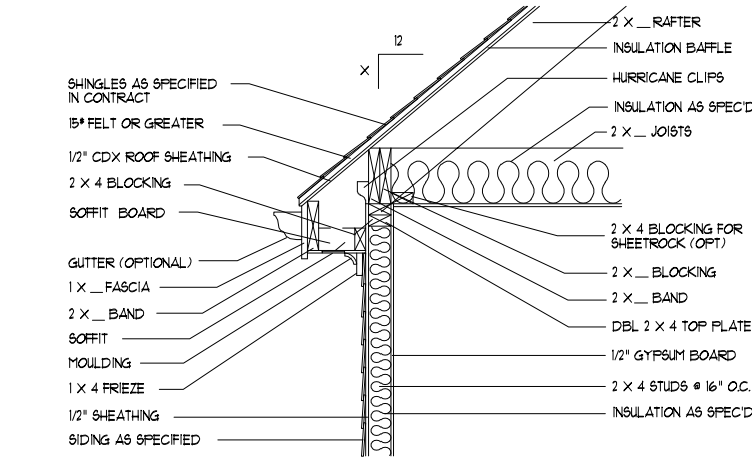

D
E-9 (NTS)

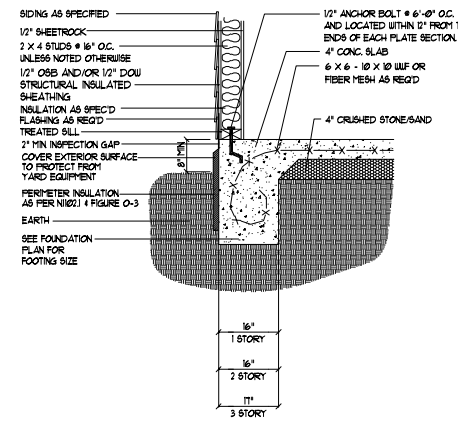

D
F-12 (NTS)

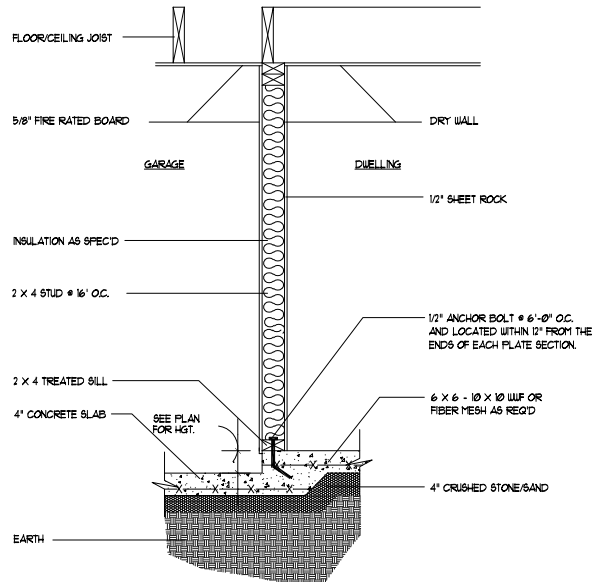

D
GU-1A (NTS)

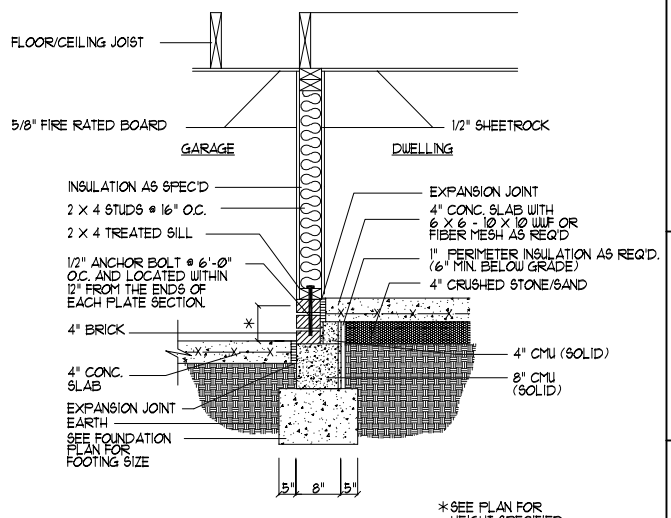

D
GU-1B (NTS)

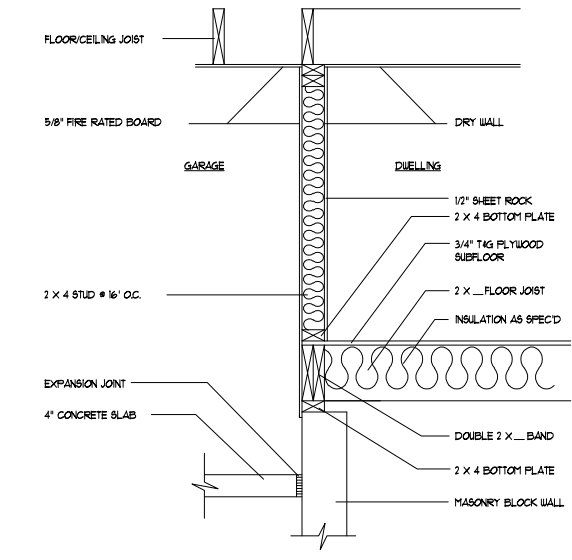

D
GU-1 (NTS)

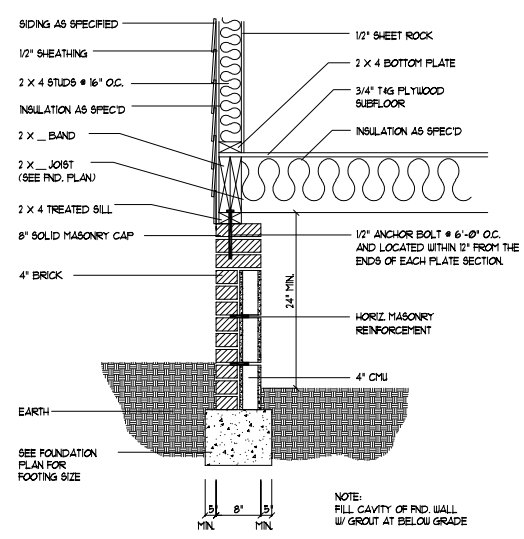

D
F-10 (NTS)

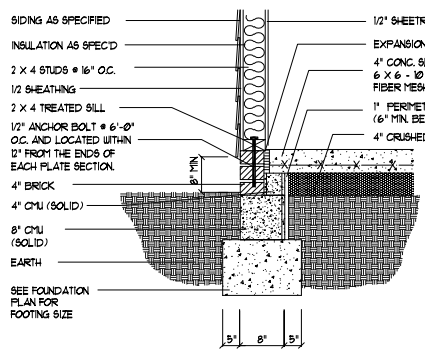

D
F-18A (NTS)

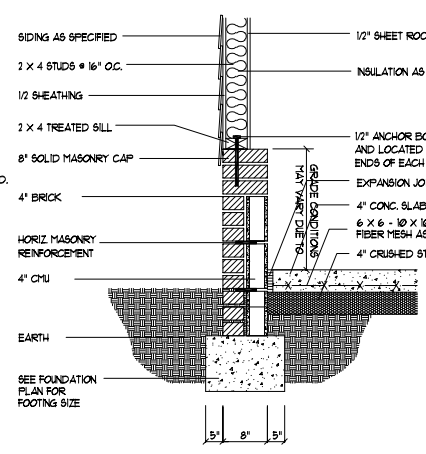

D
F-16 (NTS)

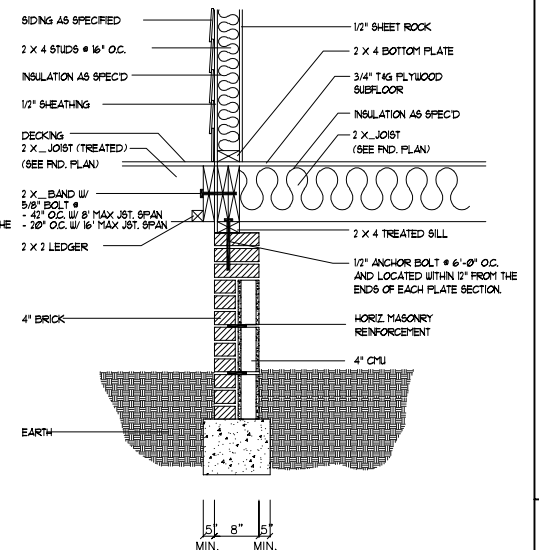

D
D-1 (NTS)

DYNAMIC DESIGN GROUP, INC
 David D Grorud
 (919) 601-1406
 DynamicDesignGroup@gmail.com

The drawings and specifications (plans) contained on these pages are the property of Dynamic Design Group and are offered to the named client or contractor for a conditional one time use. The conditional use is limited to the lot and subdivision specified herein, and only for said location. COPYRIGHT 2020
 Contractor shall verify all conditions and dimensions prior to construction. Any error or omissions shall be reported to Dynamic Design Group for corrections or justification. Once construction has commenced, the contractor shall assume all responsibility. Dimensions govern over scale, code governs over dimensions.

PROJECT FOR: CAPITOL CITY HOMES
 LOCATION: MULTI
 LOT: MULTI
 SUBDIVISION: MULTI
 COUNTY: MULTI

HAVENBROOKE
 PLAN NAME
C-2190-35GL
 PLAN I.D.
3-25-20
 DATE

D-1A
 SHEET

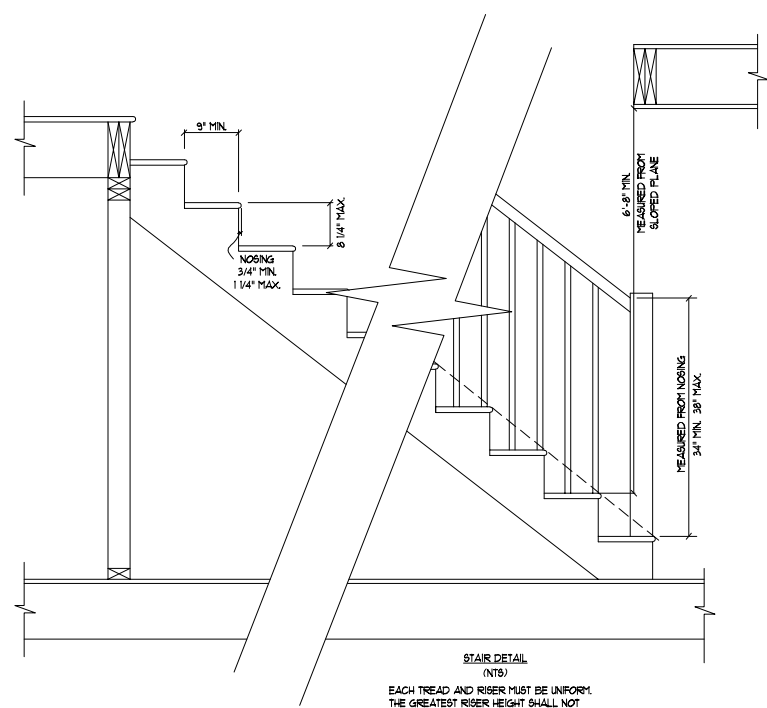

STAIR DETAIL (NTS)
 EACH TREAD AND RISER MUST BE UNIFORM. THE GREATEST RISER HEIGHT SHALL NOT EXCEED THE SMALLEST BY MORE THAN 3/8\"/>

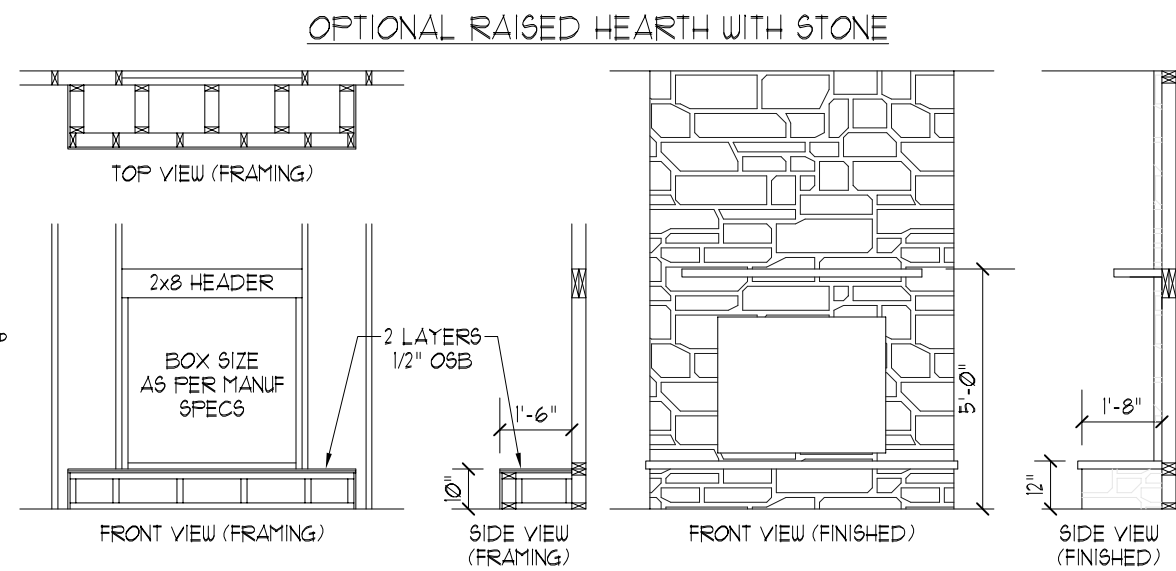
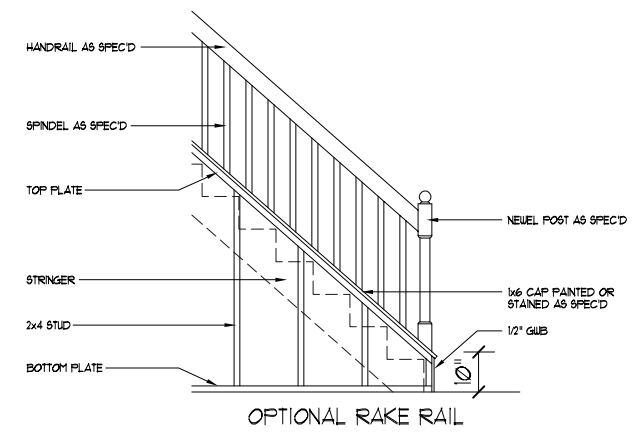
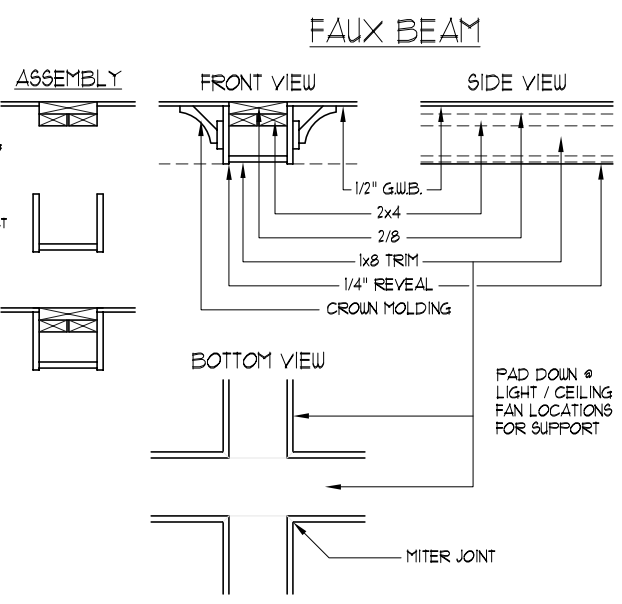
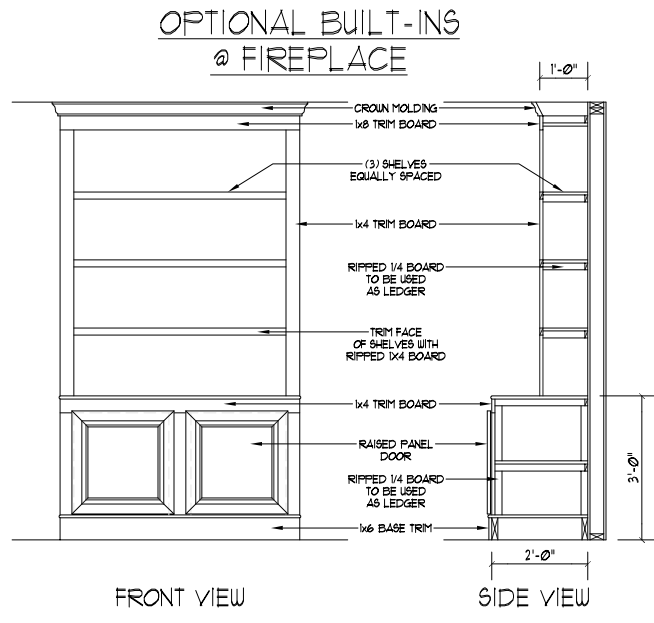
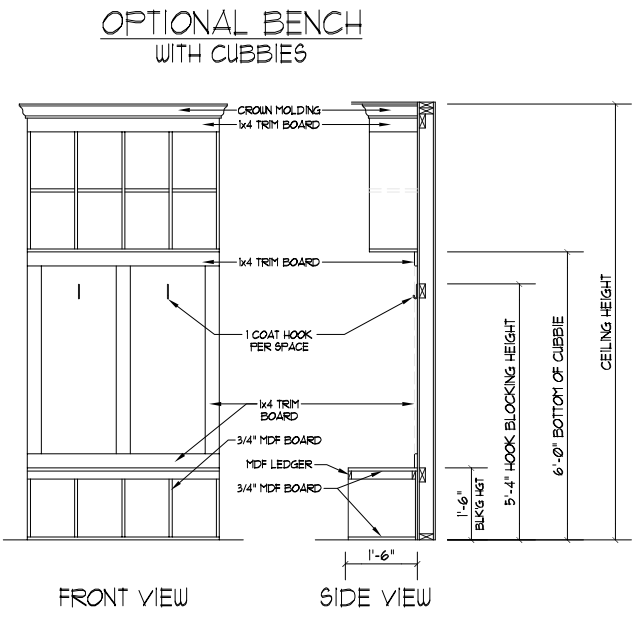
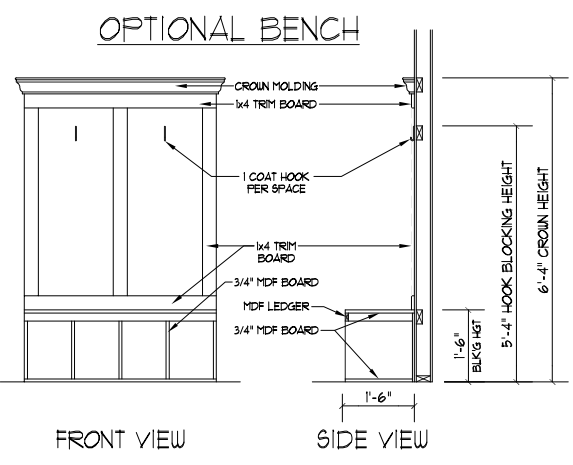
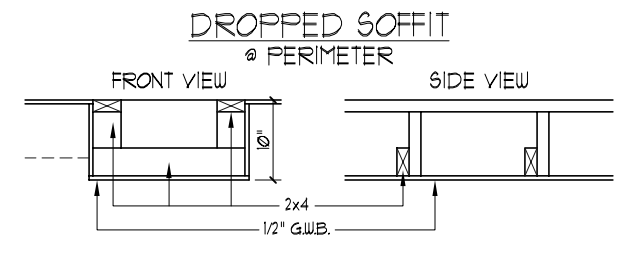
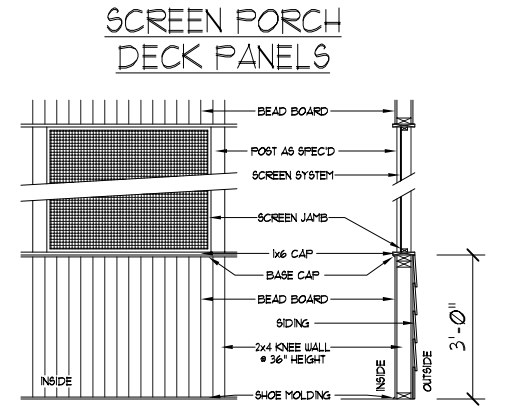
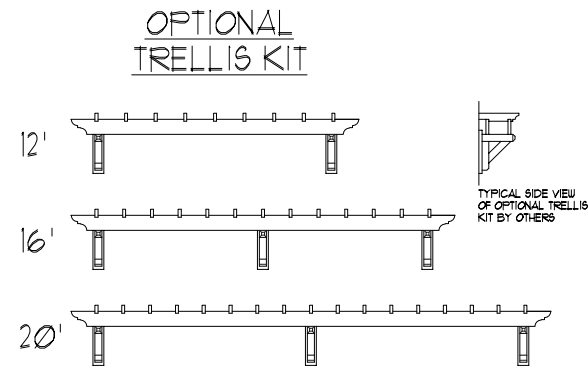

DYNAMIC DESIGN GROUP, INC
 David D Grorud
 (919) 601-1406
 DynamicDesignGroup@gmail.com

The drawings and specifications (plans) contained on these pages are the property of Dynamic Design Group and are offered to the named client or contractor for a conditional one time use. The conditional use is limited to the lot and subdivision specified herein, and only for said location. COPYRIGHT 2020
 Contractor shall verify all conditions and dimensions prior to construction. Any error or omissions shall be reported to Dynamic Design Group for corrections or justification. Once construction has commenced, the contractor shall assume all responsibility. Dimensions govern over scale, code governs over dimensions.

CAPITOL
 PROJECT FOR: CITY HOMES
 LOCATION: MULTI
 LOT: MULTI
 SUBDIVISION: MULTI
 COUNTY: MULTI

HAVENBROOKE
 PLAN NAME
C-2190-35GL
 PLAN I.D.
D-1B
 SHEET

DATE
3-25-20