

Job XXXXXXXXXX	Truss F1	Truss Type Floor	Qty 8	Ply 1	Jefferson Job Reference (optional)
-------------------	-------------	---------------------	----------	----------	---------------------------------------

Carter Components, Sanford, NC, user

Run: 8.55 S 8.50 Jun 8 2021 Print: 8.530 S Mar 28 2022 MiTek Industries, Inc. Mon Apr 25 15:49:57

Page: 1

ID:2JUGGH1L4qnnxshCiXuUhmY3VX_-z62CqHRJK21IcaGmMEnIPBg?69UmDM5Ex41JcOzN8aQ

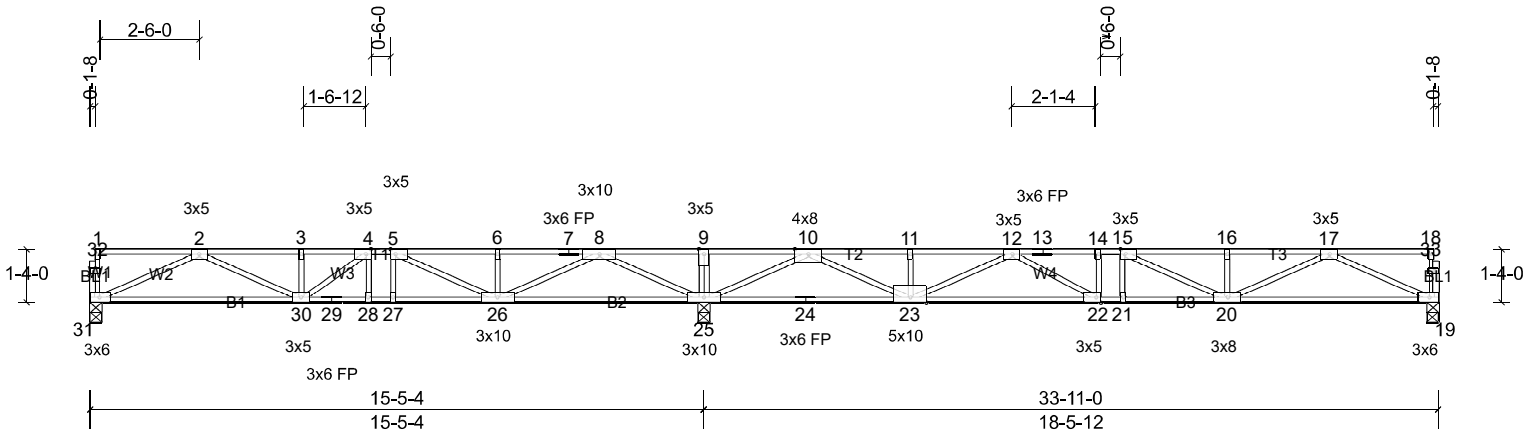

Scale = 1:58

Plate Offsets (X, Y): [4:0-1-8,Edge], [5:0-1-8,Edge], [15:0-1-8,Edge], [22:0-1-8,Edge]

Loading	(psf)	Spacing	2-0-0	CSI	DEFL	in	(loc)	l/defl	L/d	PLATES	GRIP
TCLL	40.0	Plate Grip DOL	1.00	TC	0.82	Vert(LL)	-0.22	21	>983	360	MT20 244/190
TCDL	10.0	Lumber DOL	1.00	BC	0.85	Vert(CT)	-0.29	22-23	>759	240	
BCLL	0.0	Rep Stress Incr	YES	WB	0.89	Horz(CT)	0.04	19	n/a	n/a	
BCDL	5.0	Code	IRC2018/TPI2014	Matrix-SH							Weight: 173 lb FT = 20%F, 11%E

LUMBER
 TOP CHORD 2x4 SP No.2(flat) *Except* T2:2x4 SP No.1(flat)
 BOT CHORD 2x4 SP No.2(flat)
 WEBS 2x4 SP No.3(flat)
 OTHERS 2x4 SP No.3(flat)

BRACING
 TOP CHORD Structural wood sheathing directly applied or 6-0-0 oc purlins, except end verticals.
 BOT CHORD Rigid ceiling directly applied or 6-0-0 oc bracing.

REACTIONS (lb/size) 19=797/0-3-8, (min. 0-1-8), 25=2305/0-3-8, (min. 0-1-8),
 31=589/0-3-8, (min. 0-1-8)
 Max Grav 19=853 (LC 4), 25=2305 (LC 1), 31=701 (LC 3)

FORCES (lb) - Max. Comp./Max. Ten. - All forces 250 (lb) or less except when shown.
 TOP CHORD 2-3=-1856/84, 3-4=-1856/84, 4-5=-1860/348, 5-6=-1310/834, 6-7=-1310/834, 7-8=-1310/834, 8-9=0/3033, 9-10=0/3033,
 10-11=-1528/355, 11-12=-1528/355, 12-13=-2791/0, 13-14=-2791/0, 14-15=-2791/0, 15-16=-2523/0, 16-17=-2523/0
 BOT CHORD 30-31=0/1259, 29-30=-348/1860, 28-29=-348/1860, 27-28=-348/1860, 26-27=-348/1860, 25-26=-1476/132,
 24-25=-1050/0, 23-24=-1050/0, 22-23=0/2449, 21-22=0/2791, 20-21=0/2791, 19-20=0/1586
 WEBS 9-25=-284/0, 8-25=-2191/0, 2-31=-1380/0, 8-26=0/1563, 2-30=-113/660, 6-26=-270/0, 3-30=-262/0, 5-26=-995/0,
 4-30=-5/509, 10-25=-2493/0, 17-19=-1740/0, 10-23=0/1864, 17-20=0/1036, 11-23=-262/0, 16-20=-285/0, 12-23=-1148/0,
 15-20=-360/290, 12-22=0/735

- NOTES**
- 1) Unbalanced floor live loads have been considered for this design.
 - 2) All plates are 1.5x3 MT20 unless otherwise indicated.
 - 3) This truss is designed in accordance with the 2018 International Residential Code sections R502.11.1 and R802.10.2 and referenced standard ANSI/TPI 1.
 - 4) Recommend 2x6 strongbacks, on edge, spaced at 10-00-00 oc and fastened to each truss with 3-10d (0.131" X 3") nails. Strongbacks to be attached to walls at their outer ends or restrained by other means.
 - 5) CAUTION, Do not erect truss backwards.

LOAD CASE(S) Standard

Job XXXXXXXXXX	Truss F2	Truss Type Floor	Qty 2	Ply 1	Jefferson Job Reference (optional)
-------------------	-------------	---------------------	----------	----------	---------------------------------------

Carter Components, Sanford, NC, user

Run: 8.55 S 8.50 Jun 8 2021 Print: 8.530 S Mar 28 2022 MiTek Industries, Inc. Mon Apr 25 15:49:58

Page: 1

ID:2UGGH1L4qnnxshCiXuUhMy3VX_-NhjKTJTcdzQtT2?K1MKT0plyMWTQo3he2FzCjzN8aN

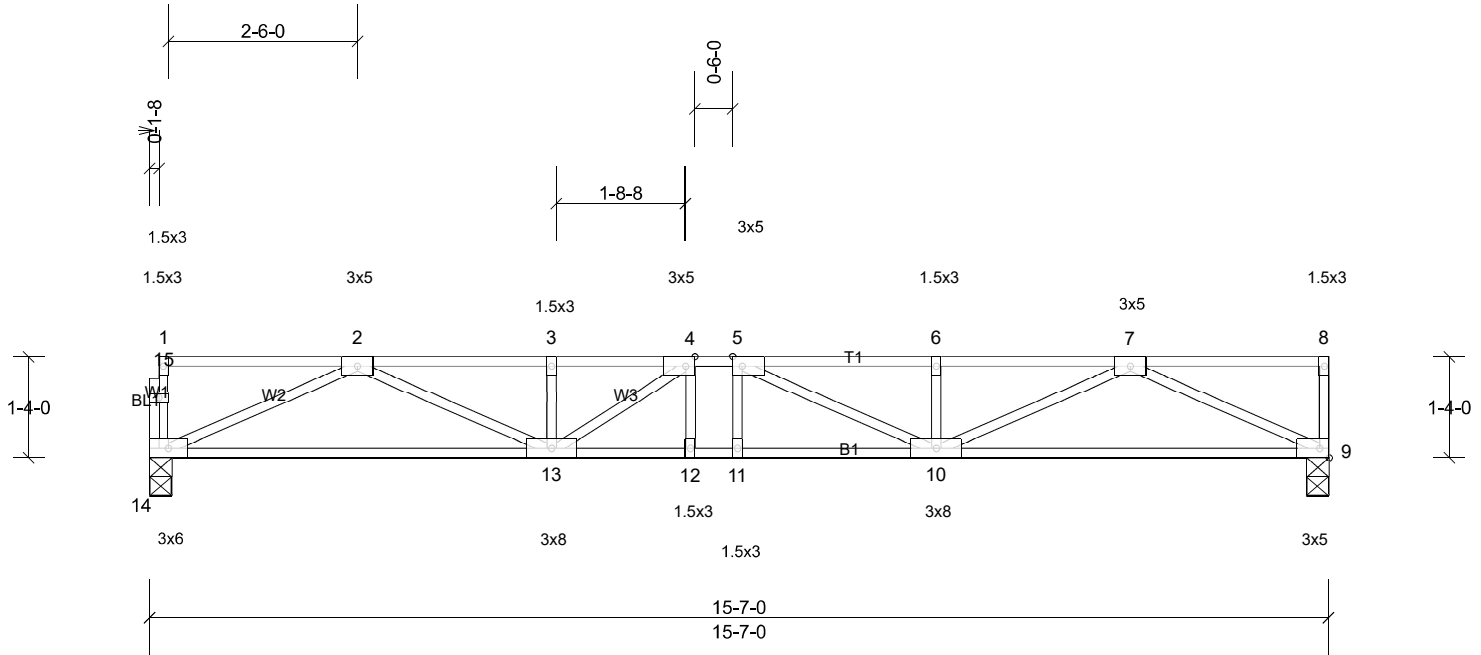

Scale = 1:30.5

Plate Offsets (X, Y): [4:0-1-8,Edge], [5:0-1-8,Edge]

Loading	(psf)	Spacing	2-0-0	CSI	DEFL	in	(loc)	l/defl	L/d	PLATES	GRIP	
TCLL	40.0	Plate Grip DOL	1.00	TC	0.46	Vert(LL)	-0.17	10-11	>999	360	MT20	244/190
TCDL	10.0	Lumber DOL	1.00	BC	0.85	Vert(CT)	-0.23	10-11	>807	240		
BCLL	0.0	Rep Stress Incr	YES	WB	0.49	Horz(CT)	0.05	9	n/a	n/a		
BCDL	5.0	Code	IRC2018/TPI2014	Matrix-SH							Weight: 80 lb	FT = 20%F, 11%E

LUMBER
TOP CHORD 2x4 SP No.2(flat)
BOT CHORD 2x4 SP No.2(flat)
WEBS 2x4 SP No.3(flat)
OTHERS 2x4 SP No.3(flat)

BRACING
TOP CHORD Structural wood sheathing directly applied or 6-0-0 oc purlins, except end verticals.
BOT CHORD Rigid ceiling directly applied or 10-0-0 oc bracing.

REACTIONS (lb/size) 9=847/0-3-8, (min. 0-1-8), 14=841/0-3-8, (min. 0-1-8)

FORCES (lb) - Max. Comp./Max. Ten. - All forces 250 (lb) or less except when shown.
TOP CHORD 2-3=-2450/0, 3-4=-2450/0, 4-5=-2700/0, 5-6=-2456/0, 6-7=-2456/0
BOT CHORD 13-14=0/1561, 12-13=0/2700, 11-12=0/2700, 10-11=0/2700, 9-10=0/1530
WEBS 7-9=-1691/0, 2-14=-1713/0, 7-10=0/1024, 2-13=0/983, 6-10=-277/0, 5-10=-462/80, 4-13=-478/68

- NOTES**
- Unbalanced floor live loads have been considered for this design.
 - This truss is designed in accordance with the 2018 International Residential Code sections R502.11.1 and R802.10.2 and referenced standard ANSI/TPI 1.
 - Recommend 2x6 strongbacks, on edge, spaced at 10-00-00 oc and fastened to each truss with 3-10d (0.131" X 3") nails. Strongbacks to be attached to walls at their outer ends or restrained by other means.
 - CAUTION, Do not erect truss backwards.

LOAD CASE(S) Standard

Job XXXXXXXX	Truss F3GR	Truss Type Floor Girder	Qty 1	Ply 1	Jefferson Job Reference (optional)
-----------------	---------------	----------------------------	----------	----------	---------------------------------------

Carter Components, Sanford, NC, user

Run: 8.55 S 8.50 Jun 8 2021 Print: 8.530 S Mar 28 2022 MiTek Industries, Inc. Mon Apr 25 15:49:59

Page: 1

ID:T3yPv3OANI9MoJQnOfRBJ?y3VWx-rtHgfUEOHYk5BaXb4sIZ1rfDmtB9Adqsi?Xl9zN8aM

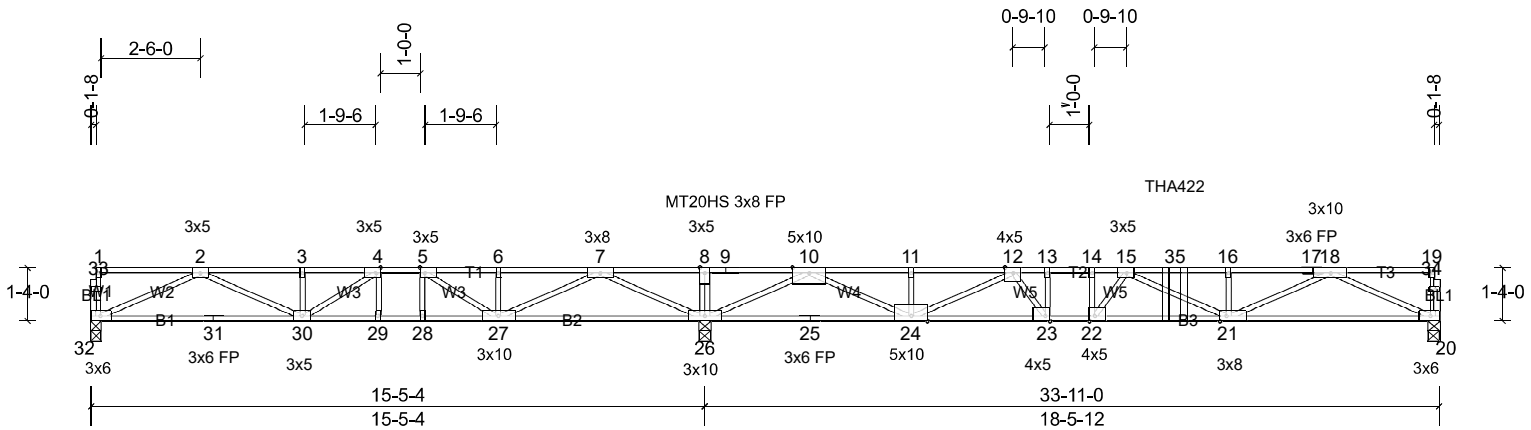

Scale = 1:58

Plate Offsets (X, Y): [4:0-1-8,Edge], [5:0-1-8,Edge], [21:0-1-12,Edge], [22:0-1-8,Edge], [23:0-1-8,Edge]

Loading	(psf)	Spacing	2-0-0	CSI	DEFL	in	(loc)	l/defl	L/d	PLATES	GRIP	
TCLL	40.0	Plate Grip DOL	1.00	TC	0.94	Vert(LL)	-0.25	21-22	>867	360	MT20	244/190
TCDL	10.0	Lumber DOL	1.00	BC	0.82	Vert(CT)	-0.34	21-22	>648	240	MT20HS	187/143
BCLL	0.0	Rep Stress Incr	NO	WB	0.79	Horz(CT)	0.05	20	n/a	n/a		
BCDL	5.0	Code	IRC2018/TPI2014	Matrix-SH								Weight: 173 lb FT = 20%F, 11%E

LUMBER

TOP CHORD 2x4 SP No.1(flat) *Except* T3:2x4 SP No.2(flat), T2:2x4 SP 2400F 2.0E (flat)
 BOT CHORD 2x4 SP No.2(flat) *Except* B3:2x4 SP 2400F 2.0E(flat)
 WEBS 2x4 SP No.3(flat) *Except* W4:2x4 SP No.2(flat)
 OTHERS 2x4 SP No.3(flat)

BRACING

TOP CHORD Structural wood sheathing directly applied or 5-6-9 oc purlins, except end verticals.
 BOT CHORD Rigid ceiling directly applied or 6-0-0 oc bracing.

REACTIONS (lb/size) 20=1006/0-3-8, (min. 0-1-8), 26=2406/0-3-8, (min. 0-1-8), 32=595/0-3-0, (min. 0-1-8)
 Max Grav 20=1088 (LC 7), 26=2406 (LC 1), 32=681 (LC 3)

FORCES

(lb) - Max. Comp./Max. Ten. - All forces 250 (lb) or less except when shown.
 TOP CHORD 2-3=-1784/47, 3-4=-1784/47, 4-5=-1675/368, 5-6=-1117/787, 6-7=-1117/787, 7-8=0/2951, 8-9=0/2951, 9-10=0/2951, 10-11=-2068/0, 11-12=-2068/0, 12-13=-3576/0, 13-14=-3576/0, 14-15=-3576/0, 15-35=-3579/0, 16-35=-3579/0, 16-17=-3579/0, 17-18=-3579/0
 BOT CHORD 31-32=0/1214, 30-31=0/1214, 29-30=-368/1675, 28-29=-368/1675, 27-28=-368/1675, 26-27=-1401/0, 25-26=-876/281, 24-25=-876/281, 23-24=0/3224, 22-23=0/3576, 21-22=0/3985, 20-21=0/2087
 WEBS 8-26=-282/0, 2-32=-1331/0, 7-26=-2178/0, 2-30=-88/630, 3-30=-301/0, 7-27=0/1515, 4-30=0/588, 5-27=-1001/0, 10-26=-2783/0, 18-20=-2292/0, 10-24=0/2157, 11-24=-278/0, 18-21=0/1649, 16-21=-443/0, 12-24=-1452/0, 15-21=-473/0, 12-23=0/997, 15-22=-1001/0, 13-23=-644/0, 14-22=0/683

NOTES

- 1) Unbalanced floor live loads have been considered for this design.
- 2) All plates are MT20 plates unless otherwise indicated.
- 3) All plates are 1.5x3 MT20 unless otherwise indicated.
- 4) Provide mechanical connection (by others) of truss to bearing plate at joint(s) 32.
- 5) This truss is designed in accordance with the 2018 International Residential Code sections R502.11.1 and R802.10.2 and referenced standard ANSI/TPI 1.
- 6) Recommend 2x6 strongbacks, on edge, spaced at 10-00-00 oc and fastened to each truss with 3-10d (0.131" X 3") nails. Strongbacks to be attached to walls at their outer ends or restrained by other means.
- 7) CAUTION, Do not erect truss backwards.
- 8) Use Simpson Strong-Tie THA422 (Single Chord Girder) or equivalent at 27-3-4 from the left end to connect truss(es) F4GR (1 ply 2x4 SP) to front face of top chord.
- 9) Fill all nail holes where hanger is in contact with lumber.

LOAD CASE(S) Standard

- 1) Dead + Floor Live (balanced): Lumber Increase=1.00, Plate Increase=1.00
 Uniform Loads (lb/ft)
 Vert: 20-32=-10, 1-19=-100
 Concentrated Loads (lb)
 Vert: 35=-316

Job XXXXXXXXXX	Truss F4GR	Truss Type Floor Girder	Qty 1	Ply 1	Jefferson Job Reference (optional)
-------------------	---------------	----------------------------	----------	----------	---------------------------------------

Carter Components, Sanford, NC, user

Run: 8.55 S 8.50 Jun 8 2021 Print: 8.530 S Mar 28 2022 MiTek Industries, Inc. Mon Apr 25 15:49:59

Page: 1

ID:T3yPv3OANI9MoJQnOfRBJ?y3VWx-rtHjgfUEOHYk5BaXb4siZ1rfvm0s9KJqsi?Xl9zN8aM

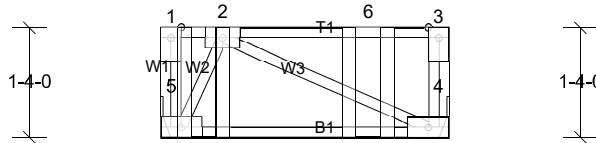
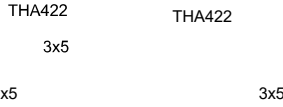
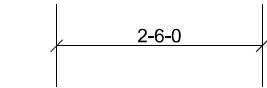

Scale = 1:28

Loading	(psf)	Spacing	2-0-0	CSI		DEFL	in	(loc)	l/defl	L/d	PLATES	GRIP
TCLL	40.0	Plate Grip DOL	1.00	TC	0.96	Vert(LL)	n/a	-	n/a	999	MT20	244/190
TCDL	10.0	Lumber DOL	1.00	BC	0.20	Vert(CT)	-0.02	4-5	>999	240		
BCLL	0.0	Rep Stress Incr	NO	WB	0.17	Horz(CT)	0.00	4	n/a	n/a		
BCDL	5.0	Code	IRC2018/TP12014	Matrix-P							Weight: 23 lb	FT = 20%F, 11%E

LUMBER

TOP CHORD 2x4 SP No.1(flat)
 BOT CHORD 2x4 SP No.2(flat)
 WEBS 2x4 SP No.3(flat)

BRACING

TOP CHORD Structural wood sheathing directly applied or 3-6-0 oc purlins, except end verticals.
 BOT CHORD Rigid ceiling directly applied or 10-0-0 oc bracing.

REACTIONS (lb/size) 4=416/ Mechanical, (min. 0-1-8), 5=466/ Mechanical, (min. 0-1-8)

FORCES (lb) - Max. Comp./Max. Ten. - All forces 250 (lb) or less except when shown.

BOT CHORD 4-5=0/334
 WEBS 2-4=-368/0, 2-5=-728/0

NOTES

- Refer to girder(s) for truss to truss connections.
- This truss is designed in accordance with the 2018 International Residential Code sections R502.11.1 and R802.10.2 and referenced standard ANSI/TP1 1.
- Recommend 2x6 strongbacks, on edge, spaced at 10-00-00 oc and fastened to each truss with 3-10d (0.131" X 3") nails. Strongbacks to be attached to walls at their outer ends or restrained by other means.
- Use Simpson Strong-Tie THA422 (Single Chord Girder) or equivalent spaced at 2-0-0 oc max. starting at 0-6-4 from the left end to 2-6-4 to connect truss(es) F5 (1 ply 2x4 SP) to front face of top chord.
- Fill all nail holes where hanger is in contact with lumber.

LOAD CASE(S) Standard

- Dead + Floor Live (balanced): Lumber Increase=1.00, Plate Increase=1.00
 Uniform Loads (lb/ft)
 Vert: 4-5=-10, 1-3=-100
 Concentrated Loads (lb)
 Vert: 2=-274, 6=-251

Job XXXXXXXXXX	Truss F5	Truss Type Floor	Qty 2	Ply 1	Jefferson Job Reference (optional)
-------------------	-------------	---------------------	----------	----------	---------------------------------------

Carter Components, Sanford, NC, user

Run: 8.55 S 8.50 Jun 8 2021 Print: 8.530 S Mar 28 2022 MiTek Industries, Inc. Mon Apr 25 15:49:59

Page: 1

ID:2UGGH1L14qnnxshCiXuUhMy3VX_-rtHjgfUEOHYk5BaXb4siZ1rmim?x9Kdqsi?Xl9zN8aM

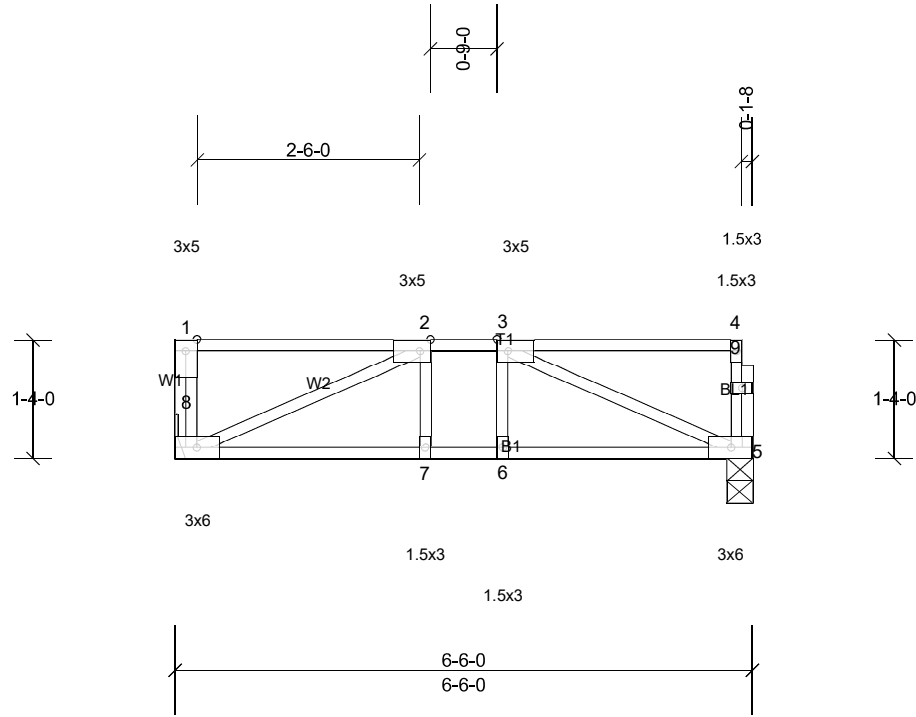

Scale = 1:25.9

Plate Offsets (X, Y): [2:0-1-8,Edge], [3:0-1-8,Edge]

Loading	(psf)	Spacing	2-0-0	CSI	DEFL	in	(loc)	l/defl	L/d	PLATES	GRIP	
TCLL	40.0	Plate Grip DOL	1.00	TC	0.46	Vert(LL)	-0.03	7-8	>999	360	MT20	244/190
TCDL	10.0	Lumber DOL	1.00	BC	0.26	Vert(CT)	-0.03	7-8	>999	240		
BCLL	0.0	Rep Stress Incr	YES	WB	0.15	Horz(CT)	0.00	5	n/a	n/a		
BCDL	5.0	Code	IRC2018/TPI2014	Matrix-SH							Weight: 37 lb	FT = 20%F, 11%E

LUMBER
 TOP CHORD 2x4 SP No.2(flat)
 BOT CHORD 2x4 SP No.2(flat)
 WEBS 2x4 SP No.3(flat)
 OTHERS 2x4 SP No.3(flat)

BRACING
 TOP CHORD Structural wood sheathing directly applied or 6-0-0 oc purlins, except end verticals.
 BOT CHORD Rigid ceiling directly applied or 10-0-0 oc bracing.

REACTIONS (lb/size) 5=338/0-3-8, (min. 0-1-8), 8=344/ Mechanical, (min. 0-1-8)

FORCES (lb) - Max. Comp./Max. Ten. - All forces 250 (lb) or less except when shown.
 TOP CHORD 2-3=-487/0
 BOT CHORD 7-8=0/487, 6-7=0/487, 5-6=0/487
 WEBS 3-5=-527/0, 2-8=-534/0

- NOTES**
- 1) Unbalanced floor live loads have been considered for this design.
 - 2) Refer to girder(s) for truss to truss connections.
 - 3) This truss is designed in accordance with the 2018 International Residential Code sections R502.11.1 and R802.10.2 and referenced standard ANSI/TPI 1.
 - 4) Recommend 2x6 strongbacks, on edge, spaced at 10-00-00 oc and fastened to each truss with 3-10d (0.131" X 3") nails. Strongbacks to be attached to walls at their outer ends or restrained by other means.
 - 5) CAUTION, Do not erect truss backwards.

LOAD CASE(S) Standard

Job XXXXXXXX	Truss F6GR	Truss Type Floor Girder	Qty 1	Ply 1	Jefferson Job Reference (optional)
-----------------	---------------	----------------------------	----------	----------	---------------------------------------

Carter Components, Sanford, NC, user

Run: 8.55 S 8.50 Jun 8 2021 Print: 8.530 S Mar 28 2022 MiTek Industries, Inc. Mon Apr 25 15:50:00

Page: 1

ID:T3yPv3OANI9MoJQnOfRBj?y3VWx-rtHjgfUEOHYk5BaXb4siZ1rfmuk9G6qsi?Xl9zN8aM

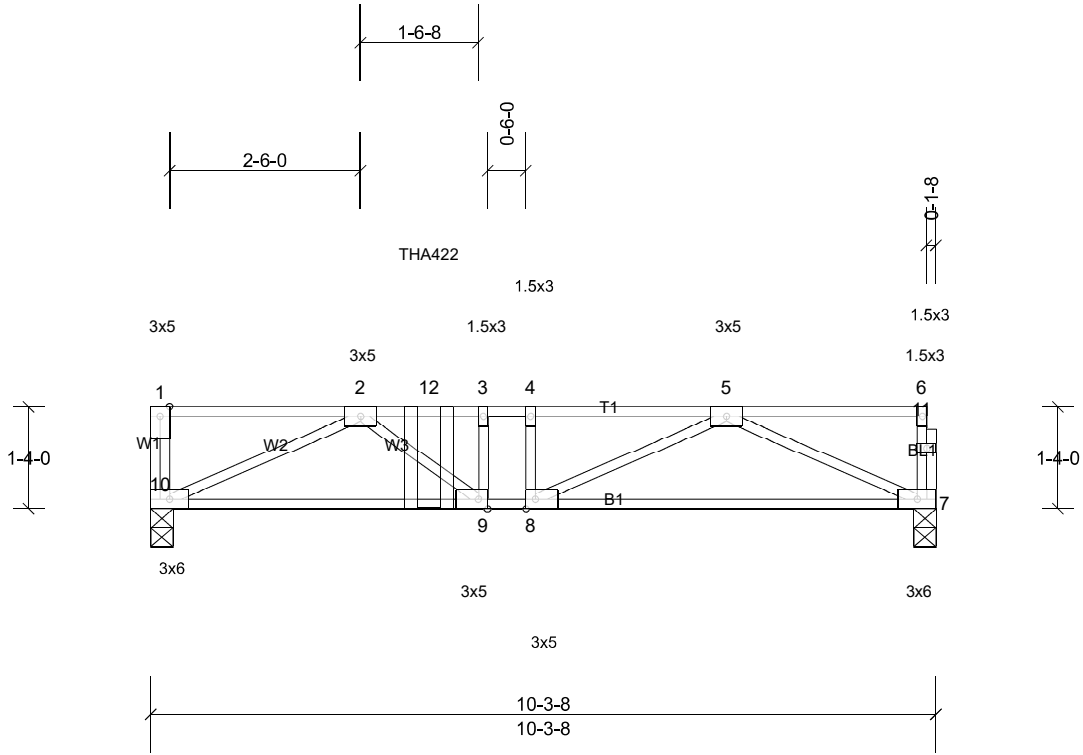

Scale = 1:30.2

Plate Offsets (X, Y): [8:0-1-8,Edge], [9:0-1-8,Edge]

Loading	(psf)	Spacing	2-0-0	CSI	0.90	DEFL	in	(loc)	l/defl	L/d	PLATES	GRIP
TCLL	40.0	Plate Grip DOL	1.00	TC	0.90	Vert(LL)	-0.08	9-10	>999	360	MT20	244/190
TCDL	10.0	Lumber DOL	1.00	BC	0.72	Vert(CT)	-0.12	9-10	>980	240		
BCLL	0.0	Rep Stress Incr	NO	WB	0.44	Horz(CT)	0.02	7	n/a	n/a		
BCDL	5.0	Code	IRC2018/TPI2014	Matrix-SH							Weight: 55 lb	FT = 20%F, 11%E

LUMBER

TOP CHORD 2x4 SP No.1(flat)
 BOT CHORD 2x4 SP No.2(flat)
 WEBS 2x4 SP No.3(flat)
 OTHERS 2x4 SP No.3(flat)

BRACING

TOP CHORD Structural wood sheathing directly applied or 6-0-0 oc purlins, except end verticals.
 BOT CHORD Rigid ceiling directly applied or 10-0-0 oc bracing.

REACTIONS (lb/size) 7=674/0-3-8, (min. 0-1-8), 10=790/0-3-8, (min. 0-1-8)

FORCES (lb) - Max. Comp./Max. Ten. - All forces 250 (lb) or less except when shown.

TOP CHORD 2-12=-1763/0, 3-12=-1763/0, 3-4=-1763/0, 4-5=-1763/0
 BOT CHORD 9-10=0/1459, 8-9=0/1763, 7-8=0/1203
 WEBS 5-7=-1319/0, 2-10=-1607/0, 5-8=0/774, 2-9=0/488, 3-9=-315/0

NOTES

- Unbalanced floor live loads have been considered for this design.
- This truss is designed in accordance with the 2018 International Residential Code sections R502.11.1 and R802.10.2 and referenced standard ANSI/TPI 1.
- Recommend 2x6 strongbacks, on edge, spaced at 10-00-00 oc and fastened to each truss with 3-10d (0.131" X 3") nails. Strongbacks to be attached to walls at their outer ends or restrained by other means.
- CAUTION, Do not erect truss backwards.
- Use Simpson Strong-Tie THA422 (Single Chord Girder) or equivalent at 3-7-12 from the left end to connect truss(es) F4GR (1 ply 2x4 SP) to back face of top chord.
- Fill all nail holes where hanger is in contact with lumber.

LOAD CASE(S) Standard

- Dead + Floor Live (balanced): Lumber Increase=1.00, Plate Increase=1.00
 Uniform Loads (lb/ft)
 Vert: 7-10=-10, 1-6=-100
 Concentrated Loads (lb)
 Vert: 12=-366

Job XXXXXXXXXX	Truss F7	Truss Type Floor	Qty 6	Ply 1	Jefferson Job Reference (optional)
-------------------	-------------	---------------------	----------	----------	---------------------------------------

Carter Components, Sanford, NC, user

Run: 8.55 S 8.50 Jun 8 2021 Print: 8.530 S Mar 28 2022 MiTek Industries, Inc. Mon Apr 25 15:50:00

Page: 1

ID:WgqfUNMwr7veZ?GPGFPJYay3VWz-J4r5u?Vs9bgbl8j9nNx5ENpUACKubAz5Mk4HczN8aL

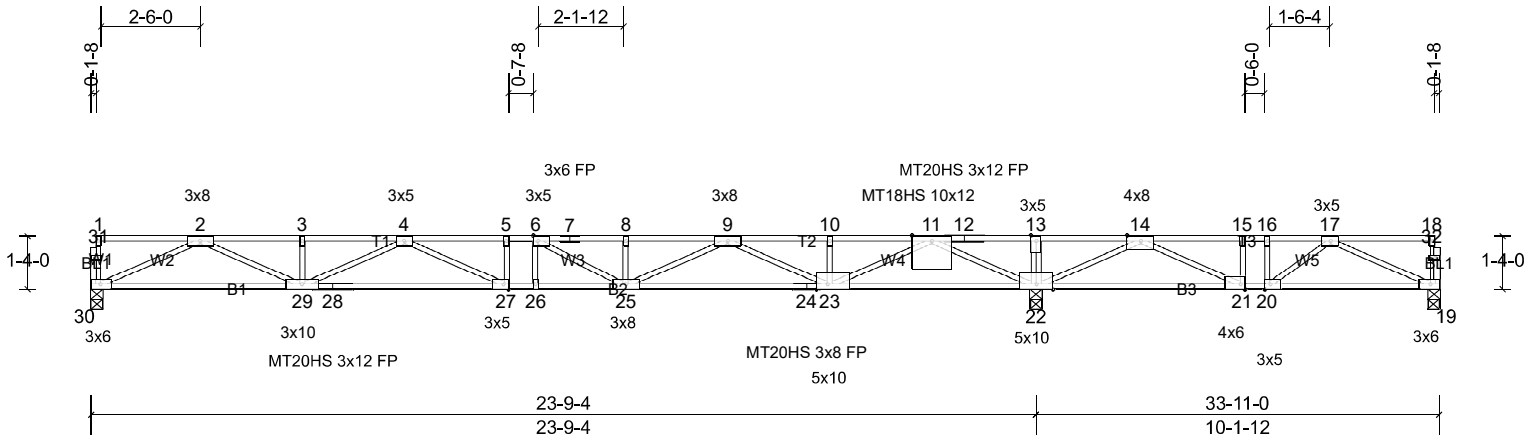

Scale = 1:58

Plate Offsets (X, Y): [6:0-1-8,Edge], [20:0-1-8,Edge], [21:0-1-8,Edge], [23:0-3-4,Edge], [27:0-1-8,Edge]

Loading	(psf)	Spacing	2-0-0	CSI	0.97	DEFL	in (loc)	l/defl	L/d	PLATES	GRIP
TCLL	40.0	Plate Grip DOL	1.00	TC	0.97	Vert(LL)	-0.47 27-29	>599	360	MT20HS	187/143
TCDL	10.0	Lumber DOL	1.00	BC	0.89	Vert(CT)	-0.66 27-29	>431	240	MT20	244/190
BCLL	0.0	Rep Stress Incr	YES	WB	0.90	Horz(CT)	0.08 22	n/a	n/a	MT18HS	244/190
BCDL	5.0	Code	IRC2018/TPI2014	Matrix-SH							Weight: 172 lb FT = 20%F, 11%E

LUMBER

TOP CHORD 2x4 SP No.2(flat) *Except* T3:2x4 SP 2400F 2.0E(flat), T2:2x4 SP No.1 (flat)
 BOT CHORD 2x4 SP No.1(flat) *Except* B3:2x4 SP 2400F 2.0E(flat)
 WEBS 2x4 SP No.3(flat) *Except* W4:2x4 SP No.2(flat)
 OTHERS 2x4 SP No.3(flat)

BRACING

TOP CHORD Structural wood sheathing directly applied or 2-2-0 oc purlins, except end verticals.
 BOT CHORD Rigid ceiling directly applied or 6-0-0 oc bracing.

REACTIONS (lb/size) 19=-19/0-3-8, (min. 0-1-8), 22=2655/0-3-8, (min. 0-1-8), 30=1055/0-3-8, (min. 0-1-8)
 Max Uplift 19=-388 (LC 3)
 Max Grav 19=365 (LC 4), 22=2655 (LC 1), 30=1067 (LC 3)

FORCES

(lb) - Max. Comp./Max. Ten. - All forces 250 (lb) or less except when shown.
 TOP CHORD 2-3=-3431/0, 3-4=-3431/0, 4-5=-4304/0, 5-6=-4304/0, 6-7=-3775/0, 7-8=-3775/0, 8-9=-3775/0, 9-10=-940/0, 10-11=-940/0, 11-12=0/4571, 12-13=0/4571, 13-14=0/4571, 14-15=-478/1696, 15-16=-478/1696, 16-17=-478/1696
 BOT CHORD 29-30=0/2052, 28-29=0/4173, 27-28=0/4173, 26-27=0/4304, 25-26=0/4304, 24-25=0/2636, 23-24=0/2636, 22-23=-1612/0, 21-22=-3051/0, 20-21=-1696/478, 19-20=-927/532
 WEBS 13-22=-304/0, 11-22=-3266/0, 2-30=-2254/0, 11-23=0/2632, 2-29=0/1525, 10-23=-260/0, 9-23=-1900/0, 4-29=-820/0, 9-25=0/1286, 4-27=-328/519, 8-25=-267/0, 6-25=-901/0, 14-22=-2246/0, 17-19=-579/1021, 14-21=0/1753, 17-20=-1021/0, 15-21=-572/0, 16-20=0/454

NOTES

- 1) Unbalanced floor live loads have been considered for this design.
- 2) All plates are MT20 plates unless otherwise indicated.
- 3) All plates are 1.5x3 MT20 unless otherwise indicated.
- 4) One RT7A MiTek connectors recommended to connect truss to bearing walls due to UPLIFT at jt(s) 19. This connection is for uplift only and does not consider lateral forces.
- 5) This truss is designed in accordance with the 2018 International Residential Code sections R502.11.1 and R802.10.2 and referenced standard ANSI/TPI 1.
- 6) Recommend 2x6 strongbacks, on edge, spaced at 10-00-00 oc and fastened to each truss with 3-10d (0.131" X 3") nails. Strongbacks to be attached to walls at their outer ends or restrained by other means.
- 7) CAUTION, Do not erect truss backwards.

LOAD CASE(S) Standard

Job XXXXXXXX	Truss F7GE	Truss Type Floor Supported Gable	Qty 1	Ply 1	Jefferson Job Reference (optional)
-----------------	---------------	-------------------------------------	----------	----------	---------------------------------------

Carter Components, Sanford, NC, user

Run: 8.55 S 8.50 Jun 8 2021 Print: 8.530 S Mar 28 2022 MiTek Industries, Inc. Mon Apr 25 15:50:00

Page: 1

ID:xFVn7POp82HDQT?_xNzQsCy3VWw-J4r5u?Vs9bgbiL8j9nNx5ENz0APwuo7z5Mk4HczN8aL

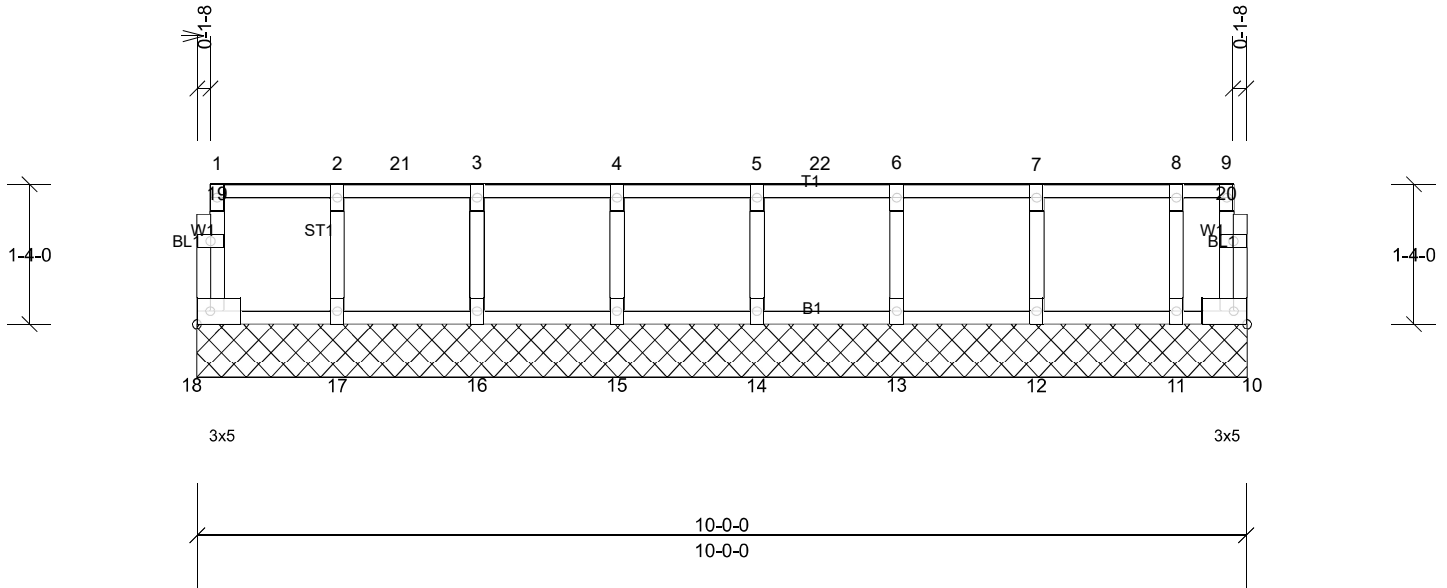

Scale = 1:22

Loading	(psf)	Spacing	2-0-0	CSI	DEFL	in	(loc)	l/defl	L/d	PLATES	GRIP	
TCLL	40.0	Plate Grip DOL	0.90	TC	0.36	Vert(LL)	n/a	-	n/a	999	MT20	244/190
TCDL	10.0	Plate Metal DOL	0.90	BC	0.02	Vert(TL)	n/a	-	n/a	999		
BCLL	0.0	Lumber DOL	0.90	WB	0.07	Horiz(TL)	n/a	-	n/a	n/a		
BCDL	5.0	Rep Stress Incr	YES	Matrix-R								
		Code	IRC2018/TPI2014								Weight: 47 lb	FT = 20%F, 11%E

LUMBER

TOP CHORD 2x4 SP No.2(flat)
 BOT CHORD 2x4 SP No.2(flat)
 WEBS 2x4 SP No.3(flat)
 OTHERS 2x4 SP No.3(flat)

BRACING

TOP CHORD Structural wood sheathing directly applied or 6'-0" oc purlins, except end verticals.
 BOT CHORD Rigid ceiling directly applied or 6'-0" oc bracing.

REACTIONS All bearings 10'-0-0.

(lb) - Max Uplift All uplift 100 (lb) or less at joint(s) 10, 18
 Max Grav All reactions 250 (lb) or less at joint(s) 10, 11, 13, 16, 18 except
 12=307 (LC 4), 14=265 (LC 4), 15=277 (LC 4), 17=261 (LC 4)

FORCES

(lb) - Max. Comp./Max. Ten. - All forces 250 (lb) or less except when shown.

WEBS 4-15=-263/4, 5-14=-251/2, 7-12=-293/6

NOTES

- 1) Unbalanced floor live loads have been considered for this design.
- 2) All plates are 1.5x3 MT20 unless otherwise indicated.
- 3) Gable requires continuous bottom chord bearing.
- 4) Truss to be fully sheathed from one face or securely braced against lateral movement (i.e. diagonal web).
- 5) Gable studs spaced at 1'-4" oc.
- 6) One RT7A MiTek connectors recommended to connect truss to bearing walls due to UPLIFT at jt(s) 18 and 10. This connection is for uplift only and does not consider lateral forces.
- 7) This truss is designed in accordance with the 2018 International Residential Code sections R502.11.1 and R802.10.2 and referenced standard ANSI/TPI 1.
- 8) Recommend 2x6 strongbacks, on edge, spaced at 10'-0" oc and fastened to each truss with 3-10d (0.131" X 3") nails. Strongbacks to be attached to walls at their outer ends or restrained by other means.
- 9) Hanger(s) or other connection device(s) shall be provided sufficient to support concentrated load(s) 246 lb down and 26 lb up at 1-11-4, 246 lb down and 26 lb up at 3-11-4, and 246 lb down and 26 lb up at 5-11-4, and 246 lb down and 26 lb up at 7-11-4 on top chord. The design/selection of such connection device(s) is the responsibility of others.

LOAD CASE(S) Standard

- 1) Dead + Snow (balanced): Lumber Increase=0.90, Plate Increase=0.90 Plt. metal=0.90
 Uniform Loads (lb/ft)
 Vert: 10-18=-10, 1-9=-20
 Concentrated Loads (lb)
 Vert: 4=-246, 7=-246, 21=-246, 22=-246

Job XXXXXXXXXX	Truss F8	Truss Type Floor	Qty 3	Ply 1	Jefferson Job Reference (optional)
-------------------	-------------	---------------------	----------	----------	---------------------------------------

Carter Components, Sanford, NC, user

Run: 8.55 S 8.50 Jun 8 2021 Print: 8.530 S Mar 28 2022 MiTek Industries, Inc. Mon Apr 25 15:50:00

Page: 1

ID:WgqfUNMwr7veZ?GPGFJjEay3VWz-J4r5u?Vs9bgbiL8j9nNx5ENq6AFSuavz5Mk4HczN8aL

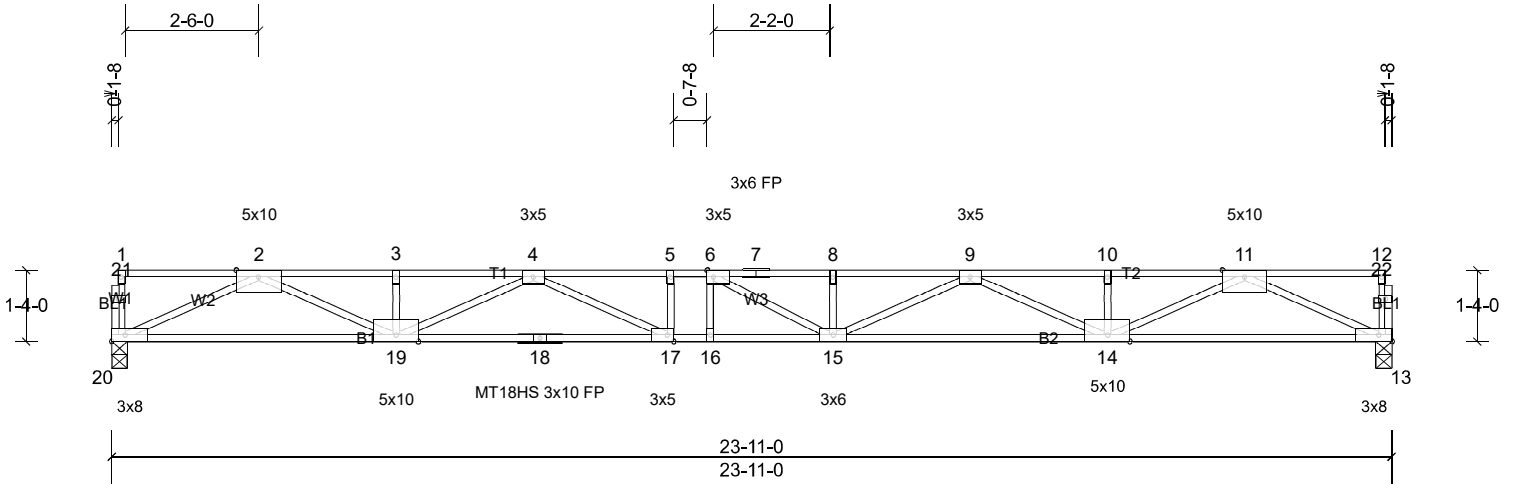

Scale = 1:43.1

Plate Offsets (X, Y): [6:0-1-8,Edge], [17:0-1-8,Edge]

Loading	(psf)	Spacing	2-0-0	CSI		DEFL	in	(loc)	l/defl	L/d	PLATES	GRIP
TCLL	40.0	Plate Grip DOL	1.00	TC	0.93	Vert(LL)	-0.66	15-16	>432	360	MT18HS	244/190
TCDL	10.0	Lumber DOL	1.00	BC	0.69	Vert(CT)	-0.90	15-16	>315	240	MT20	244/190
BCLL	0.0	Rep Stress Incr	YES	WB	0.98	Horz(CT)	0.12	13	n/a	n/a		
BCDL	5.0	Code	IRC2018/TPI2014	Matrix-SH								Weight: 121 lb FT = 20%F, 11%E

LUMBER
TOP CHORD 2x4 SP No.1(flat)
BOT CHORD 2x4 SP 2400F 2.0E(flat)
WEBS 2x4 SP No.3(flat)
OTHERS 2x4 SP No.3(flat)

BRACING
TOP CHORD Structural wood sheathing directly applied or 2-2-0 oc purlins, except end verticals.
BOT CHORD Rigid ceiling directly applied or 10-0-0 oc bracing.

REACTIONS (lb/size) 13=1295/0-3-8, (min. 0-1-8), 20=1295/0-3-8, (min. 0-1-8)

FORCES (lb) - Max. Comp./Max. Ten. - All forces 250 (lb) or less except when shown.
TOP CHORD 2-3=-4405/0, 3-4=-4405/0, 4-5=-6312/0, 5-6=-6312/0, 6-7=-6302/0, 7-8=-6302/0, 8-9=-6302/0, 9-10=-4408/0, 10-11=-4408/0
BOT CHORD 19-20=0/2544, 18-19=0/5636, 17-18=0/5636, 16-17=0/6312, 15-16=0/6312, 14-15=0/5633, 13-14=0/2546
WEBS 11-13=-2796/0, 2-20=-2795/0, 11-14=0/2059, 2-19=0/2058, 9-14=-1354/0, 4-19=-1361/0, 9-15=0/740, 4-17=0/1007, 8-15=-287/0, 6-15=-549/478

- NOTES**
- 1) Unbalanced floor live loads have been considered for this design.
 - 2) All plates are MT20 plates unless otherwise indicated.
 - 3) All plates are 1.5x3 MT20 unless otherwise indicated.
 - 4) The Fabrication Tolerance at joint 18 = 11%
 - 5) This truss is designed in accordance with the 2018 International Residential Code sections R502.11.1 and R802.10.2 and referenced standard ANSI/TPI 1.
 - 6) Recommend 2x6 strongbacks, on edge, spaced at 10-00-00 oc and fastened to each truss with 3-10d (0.131" X 3") nails. Strongbacks to be attached to walls at their outer ends or restrained by other means.

LOAD CASE(S) Standard

Job XXXXXXXX	Truss F8GE	Truss Type Floor Supported Gable	Qty 1	Ply 1	Jefferson Job Reference (optional)
-----------------	---------------	-------------------------------------	----------	----------	---------------------------------------

Carter Components, Sanford, NC, user

Run: 8.55 S 8.50 Jun 8 2021 Print: 8.530 S Mar 28 2022 MiTek Industries, Inc. Mon Apr 25 15:50:00

Page: 1

ID:WgqfUNMwr7veZ?GPGFPJGay3VWz-J4r5u?Vs9bgbiL8j9nNx5EN1PAPwupmz5Mk4HczN8aL

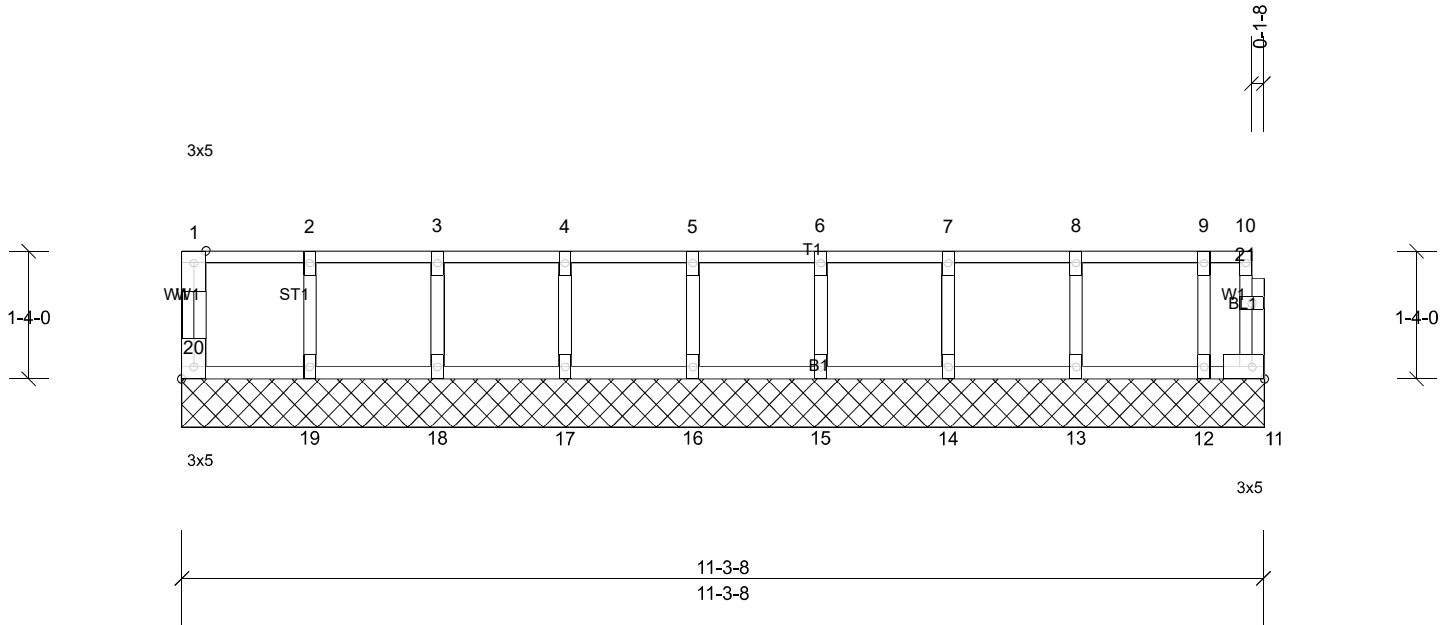

Scale = 1:24.1

Plate Offsets (X, Y): [20:Edge,0-1-8]

Loading	(psf)	Spacing	2-0-0	CSI	DEFL	in	(loc)	l/defl	L/d	PLATES	GRIP	
TCLL	40.0	Plate Grip DOL	1.00	TC	0.08	Vert(LL)	n/a	-	n/a	999	MT20	244/190
TCDL	10.0	Lumber DOL	1.00	BC	0.02	Vert(TL)	n/a	-	n/a	999		
BCLL	0.0	Rep Stress Incr	YES	WB	0.03	Horiz(TL)	n/a	-	n/a	n/a		
BCDL	5.0	Code	IRC2018/TPI2014	Matrix-R							Weight: 52 lb	FT = 20%F, 11%E

LUMBER
TOP CHORD 2x4 SP No.2(flat)
BOT CHORD 2x4 SP No.2(flat)
WEBS 2x4 SP No.3(flat)
OTHERS 2x4 SP No.3(flat)

BRACING
TOP CHORD Structural wood sheathing directly applied or 6-0-0 oc purlins, except end verticals.
BOT CHORD Rigid ceiling directly applied or 10-0-0 oc bracing.

REACTIONS All bearings 11-3-8.
(lb) - Max Grav All reactions 250 (lb) or less at joint(s) 11, 12, 13, 14, 15, 16, 17, 18, 19, 20

FORCES (lb) - Max. Comp./Max. Ten. - All forces 250 (lb) or less except when shown.

- NOTES**
- All plates are 1.5x3 MT20 unless otherwise indicated.
 - Gable requires continuous bottom chord bearing.
 - Truss to be fully sheathed from one face or securely braced against lateral movement (i.e. diagonal web).
 - Gable studs spaced at 1-4-0 oc.
 - This truss is designed in accordance with the 2018 International Residential Code sections R502.11.1 and R802.10.2 and referenced standard ANSI/TPI 1.
 - Recommend 2x6 strongbacks, on edge, spaced at 10-00-00 oc and fastened to each truss with 3-10d (0.131" X 3") nails. Strongbacks to be attached to walls at their outer ends or restrained by other means.
 - CAUTION, Do not erect truss backwards.

LOAD CASE(S) Standard