

# NEW HOUSE FOR:

# MR & MRS RAMIREZ

## 9382 OLD US 421

## BROADWAY, NORTH CAROLINA 27505

### INDEX TO DRAWINGS

CS	COVER SHEET
A-1	FIRST AND SECOND FLOOR PLANS
A-2	CONCRETE SLAB AND FOUNDATION PLAN
A-3	CONCRETE SLAB CONTROL JOINT PLAN
A-4	FIRST AND SECOND FLOOR CEILING FRAMING PLANS
A-5	ROOF FRAMING PLAN
A-6	FRONT AND REAR ELEVATIONS
A-7	LEFT AND RIGHT SIDE ELEVATIONS
A-8	SECTION THROUGH HOUSE
A-9	SECTION THROUGH GARAGE AND BONUS ROOM
A-10	SECTION THROUGH HOUSE AND PORCH DETAILS
E-1	FIRST AND SECOND FLOOR ELECTRICAL PLANS
E-2	FIRST AND SECOND FLOOR LIGHTING PLANS



COVER SHEET

### NEW HOUSE FOR: MR & MRS RAMIREZ

9382 OLD US 421  
BROADWAY, NORTH CAROLINA 27505

DATE : 05-02-2022  
PROJECT NO. 2022-15  
SCALE : SEE DRAWING FOR SCALE  
DRAWN BY : JHL  
REVISION :

THIS DRAWING IS THE PROPERTY OF  
LINDLEY ARCHITECTURE PLLC  
AND IS NOT TO BE COPIED OR REPRODUCED  
IN ANY MANNER.

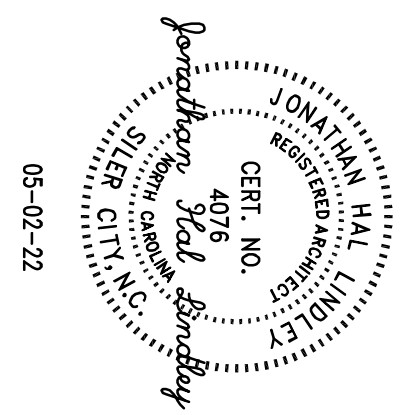

**FIRST AND SECOND FLOOR PLANS**

**NEW HOUSE FOR:  
MR & MRS RAMIREZ**

9382 OLD US 421  
BROADWAY, NORTH CAROLINA 27505

DATE :	05-02-2022
PROJECT NO :	2022-15
SCALE :	SEE DRAWING FOR SCALE
DRAWN BY :	JHL
REVISION :	

SHEET	<b>A-1</b>
OF	SHEETS

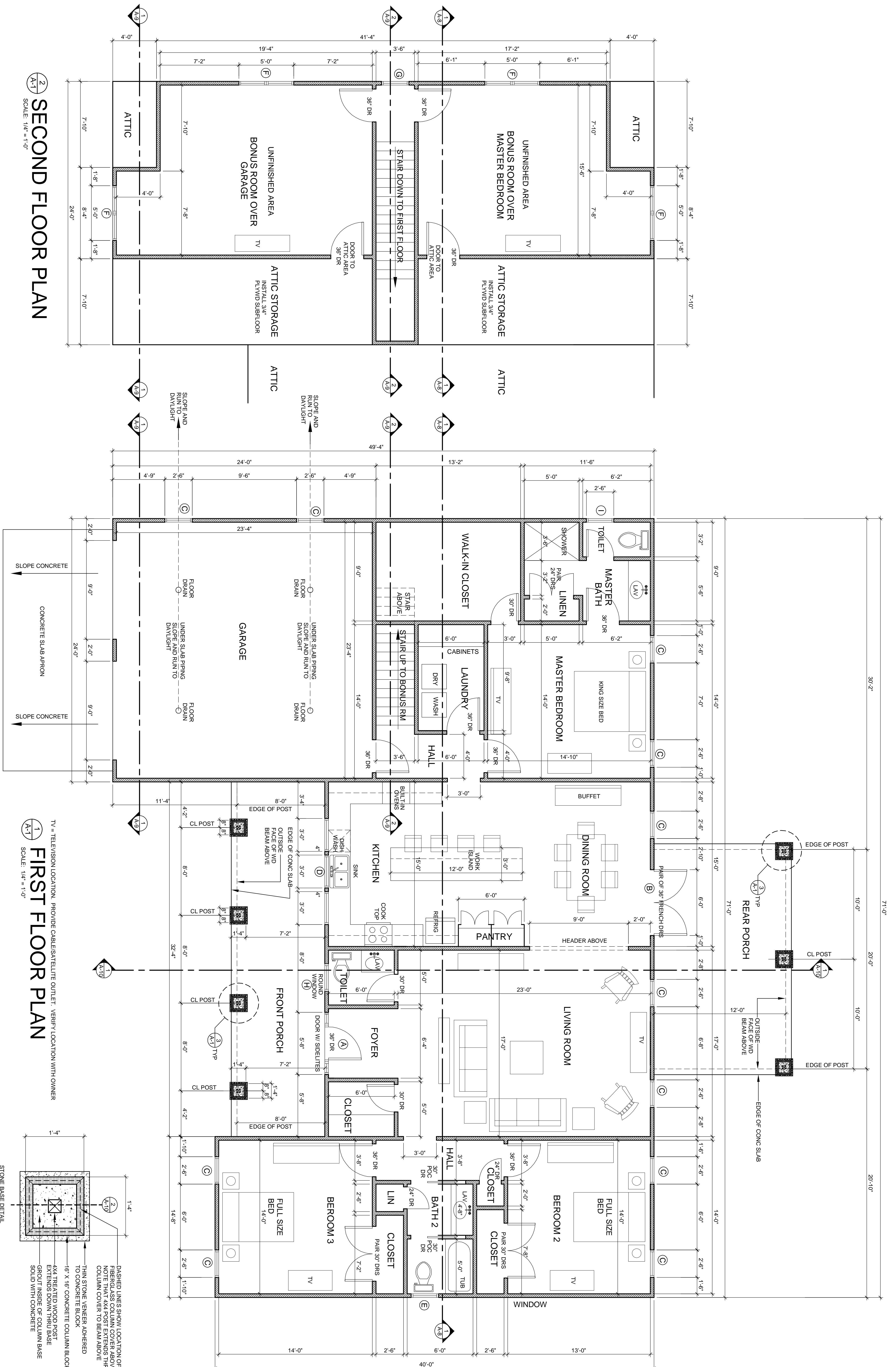

**1 FIRST FLOOR PLAN**  
SCALE: 1/4" = 1'-0"

**2 SECOND FLOOR PLAN**  
SCALE: 1/4" = 1'-0"

**3 COLUMN PLAN DETAIL**  
SCALE: 1" = 1'-0"

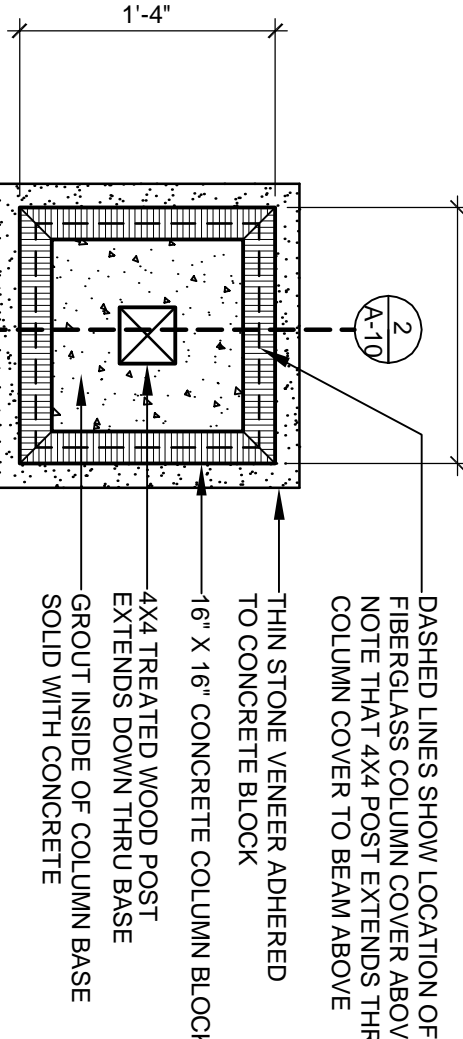

TV = TELEVISION LOCATION. PROVIDE CABLE/SATELLITE OUTLET. VERIFY LOCATION WITH OWNER

SLOPE CONCRETE

SLOPE AND RUN TO DAYLIGHT

ATTIC STORAGE  
INSTALL 3/4" PLYWOOD SUBFLOOR

UNFINISHED AREA  
BONUS ROOM OVER MASTER BEDROOM

UNFINISHED AREA  
BONUS ROOM OVER GARAGE

ATTIC

GARAGE

UNDER SLAB PIPING  
SLOPE AND RUN TO DAYLIGHT

FLOOR DRAIN

FRONT PORCH

FOYER

BEDROOM 2

BEDROOM 3

LAUNDRY

WALK-IN CLOSET

MASTER BATH

MASTER BEDROOM

DINING ROOM

KITCHEN

PANTRY

LIVING ROOM

FOYER

CLOSET

TOILET

FRONT PORCH

CL POST

CL POST

CL POST

CL POST

CL POST

CL POST

CL POST

CL POST

CL POST

CL POST

CL POST

CL POST

CL POST

CL POST

CL POST

CL POST

CL POST

CL POST

CL POST

CL POST

CL POST

CL POST

CL POST

CL POST

CL POST

CL POST

CL POST

CL POST

CL POST

CL POST

CL POST

CL POST

CL POST

CL POST

CL POST

CL POST

CL POST

CL POST

CL POST

CL POST

CL POST

CL POST

CL POST

CL POST

CL POST

CL POST

CL POST

CL POST

CL POST

CL POST

CL POST

CL POST

CL POST

CL POST

CL POST

CL POST

CL POST

CL POST

CL POST

CL POST

CL POST

CL POST

CL POST

CL POST

CL POST

CL POST

CL POST

CL POST

CL POST

CL POST

CL POST

CL POST

CL POST

CL POST

CL POST

CL POST

CL POST

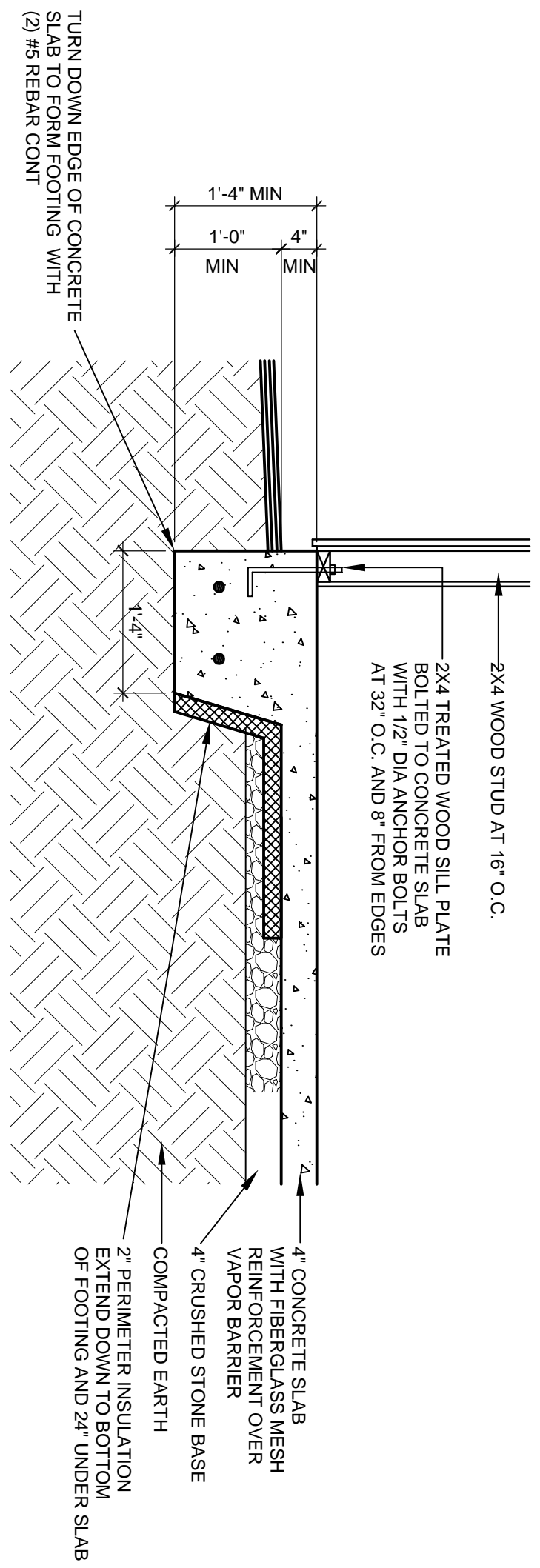

**2**  
FOOTING DETAIL  
SCALE: 3/4" = 1'-0"

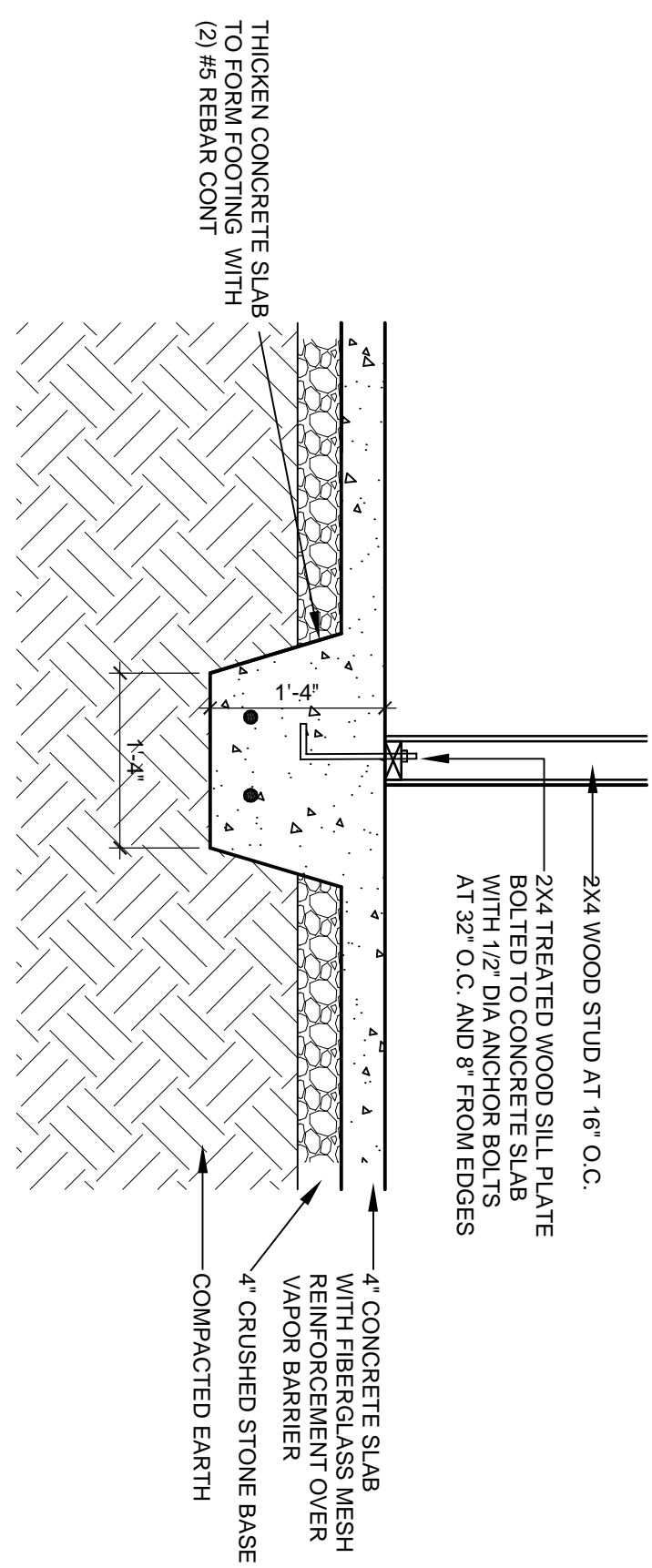

**3**  
FOOTING DETAIL  
SCALE: 3/4" = 1'-0"

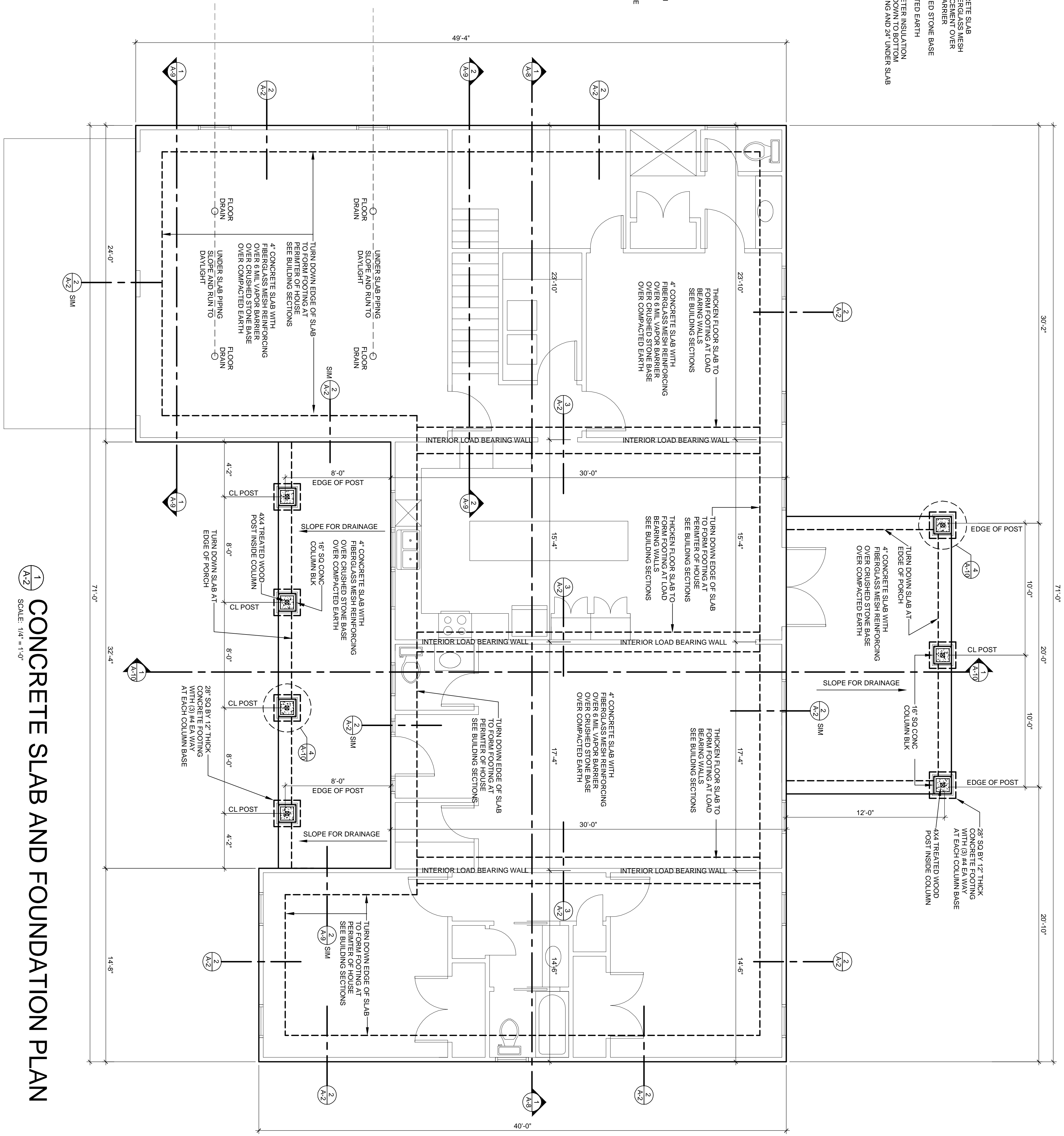

**1**  
CONCRETE SLAB AND FOUNDATION PLAN  
SCALE: 1/4" = 1'-0"

**LINDLEY ARCHITECTURE PLLC**  
ARCHITECTURE PLANNING INTERIORS  
1013 Silk Hope Lindley Mill Road  
Silver City, North Carolina 27344  
hallindley@liva.com  
919 - 985 - 0364

**Professional Seal**  
JON THAM, ARCHITECT  
CERT. NO. 0075  
LINDLEY ARCHITECTURE PLLC  
1013 SILK HOPE LINDLEY MILL ROAD  
SILVER CITY, NC 27344  
05-02-22

**CONCRETE SLAB AND FOUNDATION PLAN**  
**NEW HOUSE FOR:  
MR & MRS RAMIREZ**  
9382 OLD US 421  
BROADWAY, NORTH CAROLINA 27505

DATE : 05-02-2022  
PROJECT NO. 2022-15  
SCALE : SET DRAWING FOR SCALE  
DRAWN BY : JHL  
REVISION :  
09-16-22 CHANGE FTG SIZE

THIS DRAWING IS THE PROPERTY OF LINDLEY ARCHITECTURE PLLC AND IS NOT TO BE COPIED OR REPRODUCED IN ANY MANNER WITHOUT THE WRITTEN CONSENT OF LINDLEY ARCHITECTURE PLLC.

SHEET **A-2** OF SHEETS

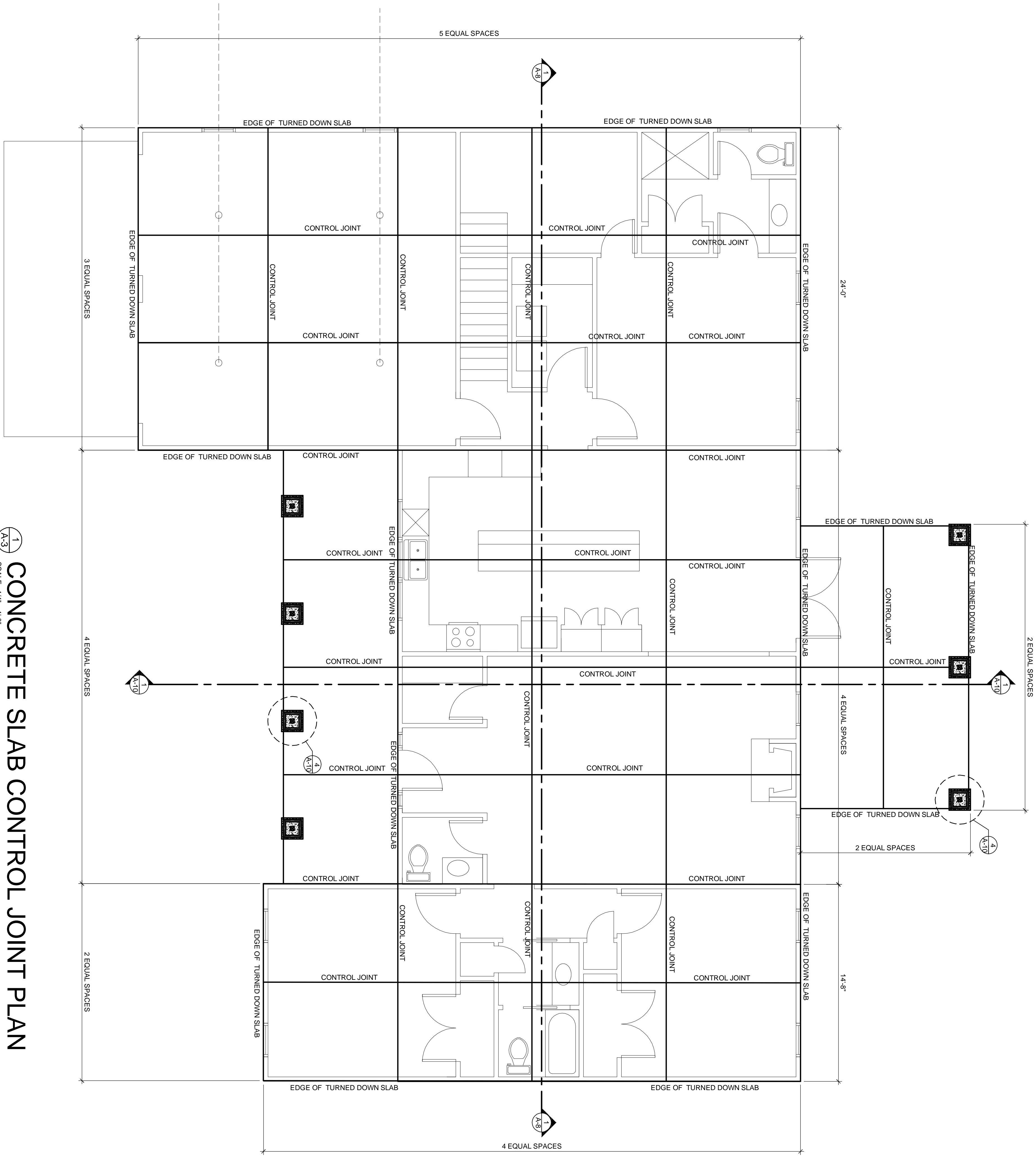

**CONCRETE SLAB CONTROL JOINT PLAN**  
 SCALE: 1/4" = 1'-0"

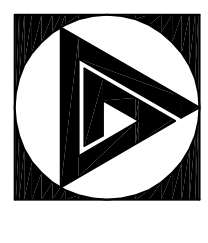
**LINDLEY**  
 ARCHITECTURE PLLC  
  
 ARCHITECTURE  
 PLANNING  
 INTERIORS  
 1013 Silk Hope Lindley Mill Road  
 Silver City, North Carolina 27344  
 hallindley@liva.com  
 919 - 985 - 0364

JON THOMAS  
 REGISTERED ARCHITECT  
 CERT. NO. 4078  
 LINDLEY ARCHITECTURE PLLC  
 1013 SILK HOPE LINDLEY MILL ROAD  
 SILVER CITY, NORTH CAROLINA 27344  
 05-02-22

**CONCRETE SLAB CONTROL JOINT PLAN**  
  
**NEW HOUSE FOR:**  
**MR & MRS RAMIREZ**  
 9382 OLD US 421  
 BROADWAY, NORTH CAROLINA 27505

DATE :	05-02-2022
PROJECT NO :	2022-15
SCALE :	SEE DRAWING FOR SCALE
DRAWN BY :	JHL
REVISION :	

THE DRAWING IS THE PROPERTY OF  
 LINDLEY ARCHITECTURE PLLC  
 AND IS NOT TO BE COPIED OR REPRODUCED  
 IN ANY MANNER WITHOUT  
 WRITTEN PERMISSION.

SHEET  
**A-3**  
 OF SHEETS

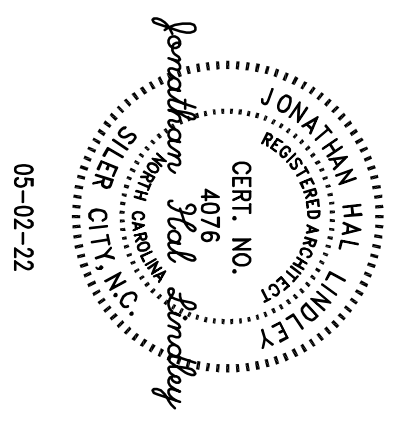
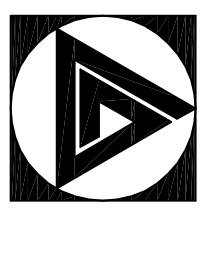

**FIRST AND SECOND FLOOR CEILING FRAMING PLANS**

**NEW HOUSE FOR:  
MR & MRS RAMIREZ**

9382 OLD US 421  
BROADWAY, NORTH CAROLINA 27505

DATE :	05-02-2022
PROJECT NO :	2022-15
SCALE :	SEE DRAWING FOR SCALE
DRAWN BY :	JHL
REVISION :	
SHEET	<b>A-4</b>
OF	SHEETS

## 1 FIRST FLOOR CEILING FRAMING PLAN

SCALE: 1/4" = 1'-0"

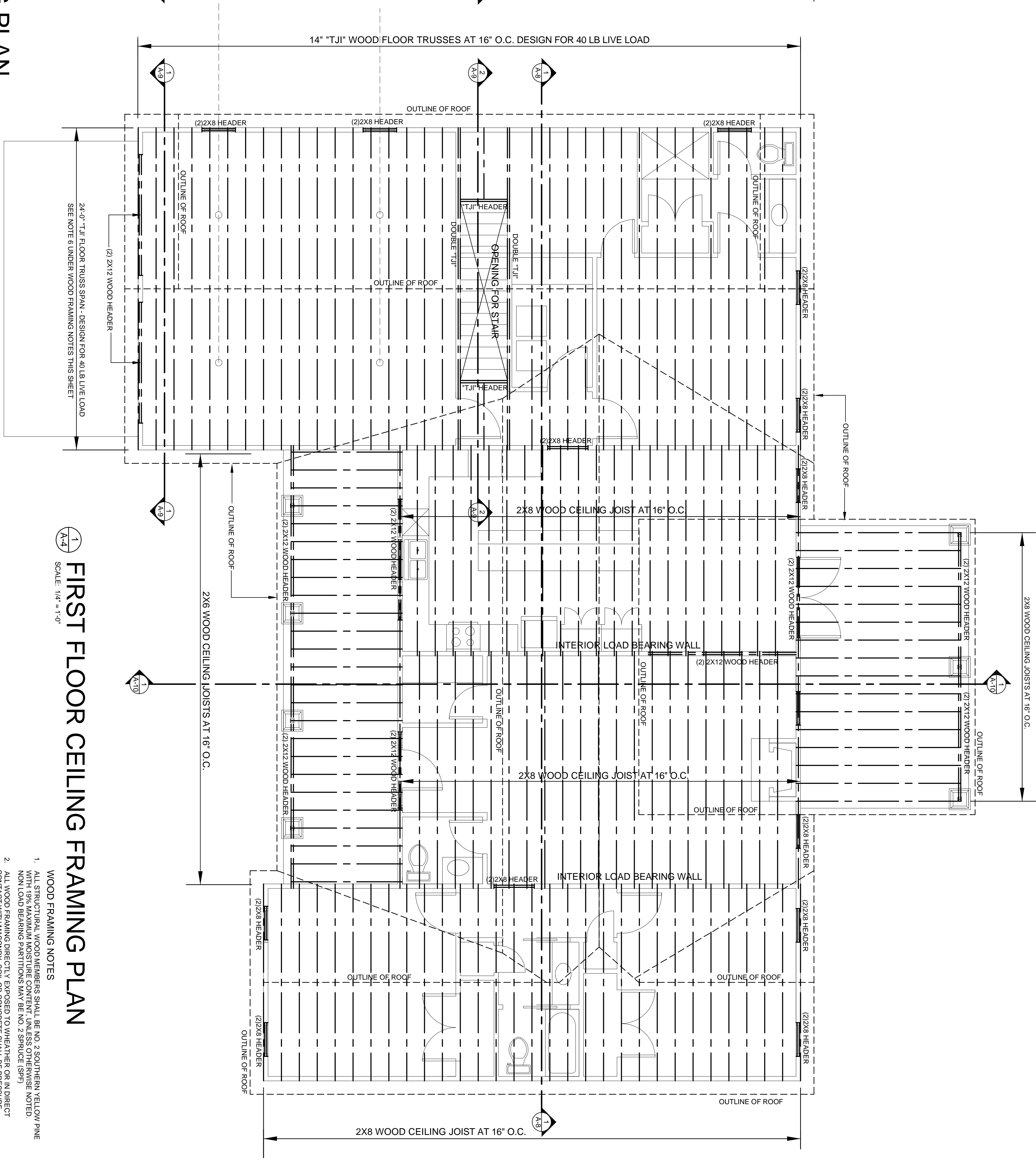

### WOOD FRAMING NOTES

1. ALL STRUCTURAL WOOD MEMBERS SHALL BE NO. 2 SOUTHERN YELLOW PINE UNLESS OTHERWISE NOTED.
2. ALL WOOD FRAMING DIRECTLY EXPOSED TO WEATHER OR IN DIRECT CONTACT WITH SOIL OR CONCRETE SHALL BE PRESURIZED TREATED UNLESS OTHERWISE NOTED.
3. ALL METAL CONNECTORS SHALL BE HOT DIP GALVANIZED. INSTALL ALL ANCHORS PER THE MANUFACTURER'S RECOMMENDATIONS. METAL CONNECTOR DESIGNATIONS INDICATED ON PLANS ARE FOR SIMPSON STRONG-TIE ANCHORS. ANCHORS FROM OTHER MANUFACTURERS MAY BE USED PROVIDED THEY HAVE EQUIVALENT STRENGTH.
4. ALL NAILLED CONNECTIONS SHALL BE IN ACCORDANCE WITH THE NORTH CAROLINA STATE BUILDING CODE TABLE 2304.6.1 FASTENING SCHEDULE UNLESS OTHERWISE NOTED.
5. FRAMING CONNECTIONS THAT ARE BOLTED OR SCREWED SHALL BE INSTALLED IN ACCORDANCE WITH THE LATEST EDITION OF THE NATIONAL DESIGN SPECIFICATION FOR WOOD.
6. TJI FLOOR TRUSSES ARE TRUSS JOIST BY WERRHAUSER (OR EQUAL). SIZES IS MINIMUM 1380 LB LIVE LOAD DEFLECTION.

## 2 SECOND FLOOR CEILING FRAMING PLAN

SCALE: 1/4" = 1'-0"

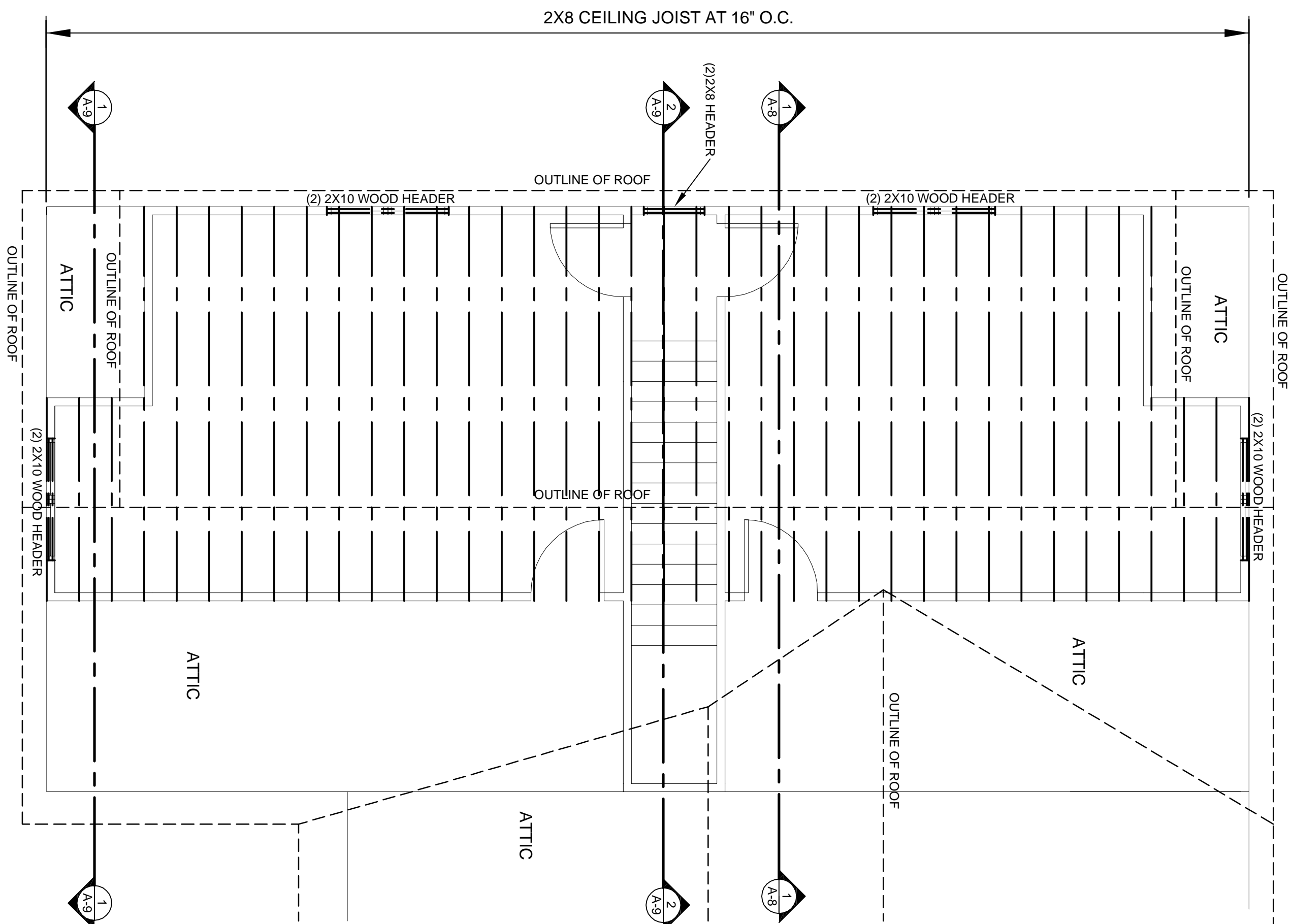

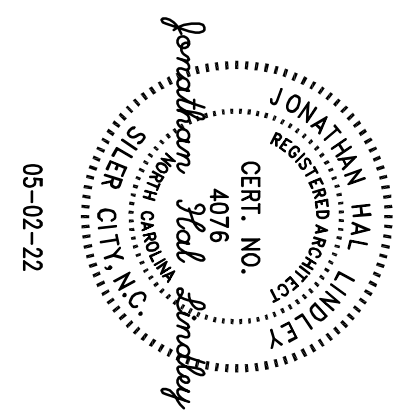
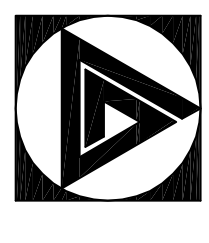

**ROOF FRAMING PLAN**  
**NEW HOUSE FOR:  
MR & MRS RAMIREZ**  
9382 OLD US 421  
BROADWAY, NORTH CAROLINA 27505

DATE : 05-02-2022  
PROJECT NO. 2022-15  
SCALE : SEE DRAWING FOR SCALE  
DRAWN BY : JHL  
REVISION :

THIS DRAWING IS THE PROPERTY OF LINDLEY ARCHITECTURE PLLC AND IS NOT TO BE COPIED OR REPRODUCED IN ANY MANNER WITHOUT THE WRITTEN CONSENT OF LINDLEY ARCHITECTURE PLLC.

SHEET  
**A-5**  
OF  
SHEETS

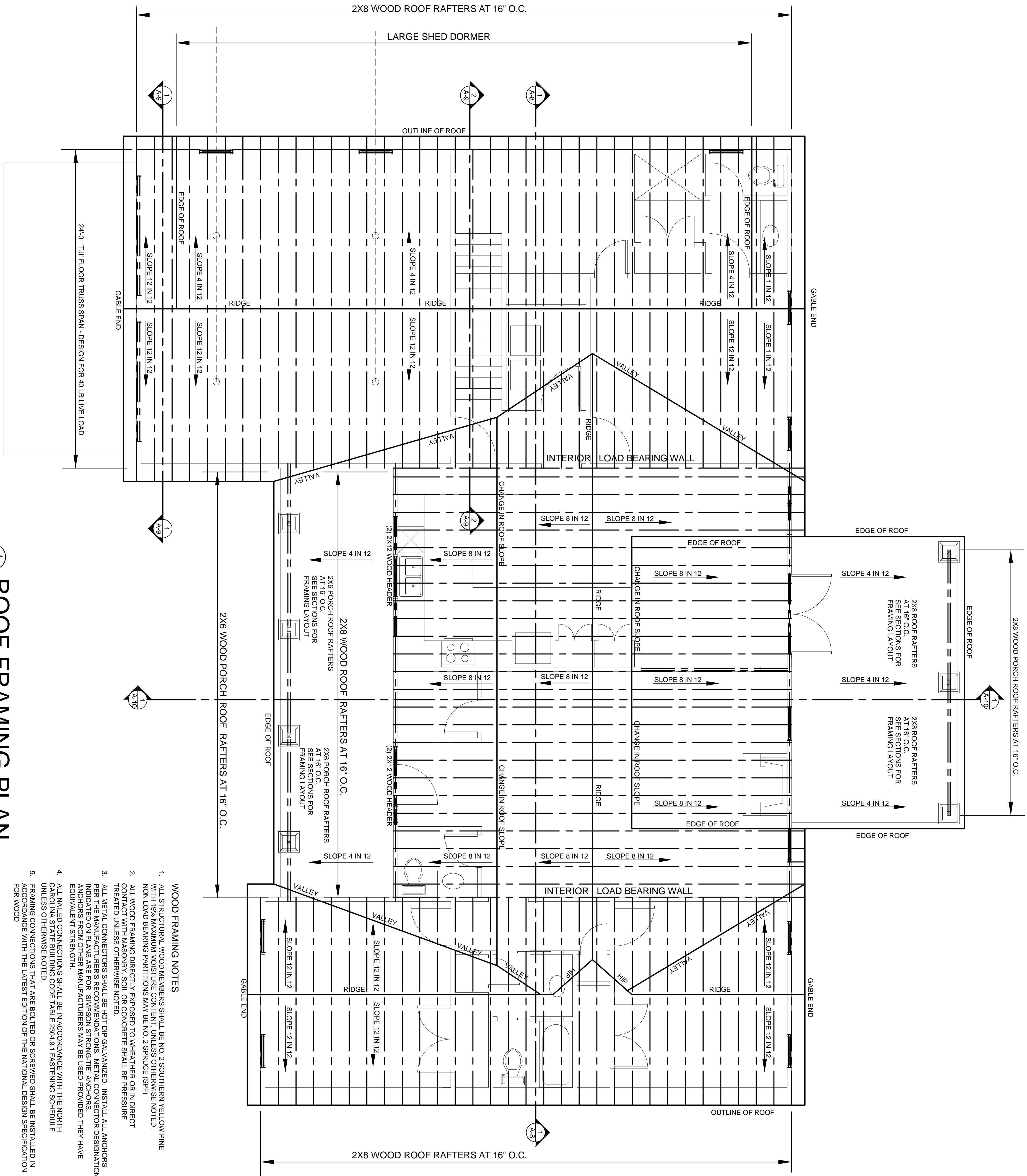

**1**  
**ROOF FRAMING PLAN**  
SCALE: 1/4" = 1'-0"

- WOOD FRAMING NOTES**
1. ALL STRUCTURAL WOOD MEMBERS SHALL BE NO. 2 SOUTHERN YELLOW PINE WITH 19% MAXIMUM MOISTURE CONTENT, UNLESS OTHERWISE NOTED. NON-LOAD BEARING PARTITIONS MAY BE NO. 2 SPRUCE (SP).
  2. ALL WOOD FRAMING DIRECTLY EXPOSED TO WEATHER OR IN DIRECT CONTACT WITH MASONRY, SOIL OR CONCRETE SHALL BE PRESSURE TREATED UNLESS OTHERWISE NOTED.
  3. ALL METAL CONNECTORS SHALL BE HOT DIP GALVANIZED. INSTALL ALL ANCHORS PER THE MANUFACTURER'S RECOMMENDATIONS. METAL CONNECTOR DESIGNATIONS AND ANCHORS FROM OTHER MANUFACTURERS MAY BE USED PROVIDED THEY HAVE EQUIVALENT STRENGTH.
  4. ALL NAIL/ED CONNECTIONS SHALL BE IN ACCORDANCE WITH THE NORTH CAROLINA STATE BUILDING CODE TABLE 2304.9.1 FASTENING SCHEDULE UNLESS OTHERWISE NOTED.
  5. FRAMING CONNECTIONS THAT ARE BOLTED OR SCREWED SHALL BE INSTALLED IN ACCORDANCE WITH THE LATEST EDITION OF THE NATIONAL DESIGN SPECIFICATION FOR WOOD.

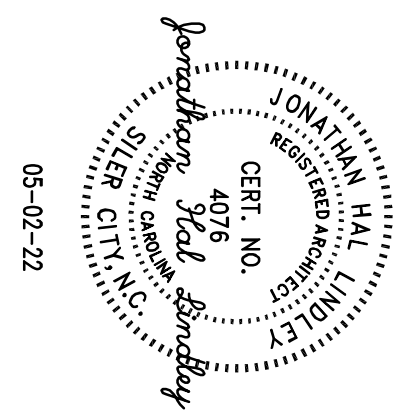
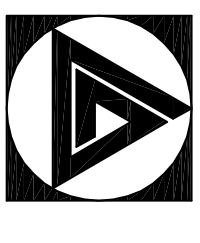

**FRONT AND REAR ELEVATIONS**

**NEW HOUSE FOR:  
 MR & MRS RAMIREZ**

9382 OLD US 421  
 BROADWAY, NORTH CAROLINA 27505

DATE : 05-02-2022  
 PROJECT NO. 2022-15  
 SCALE : SET DRAWING FOR SCALE  
 DRAWN BY : JHL  
 REVISION :

SHEET **A-6** OF SHEETS

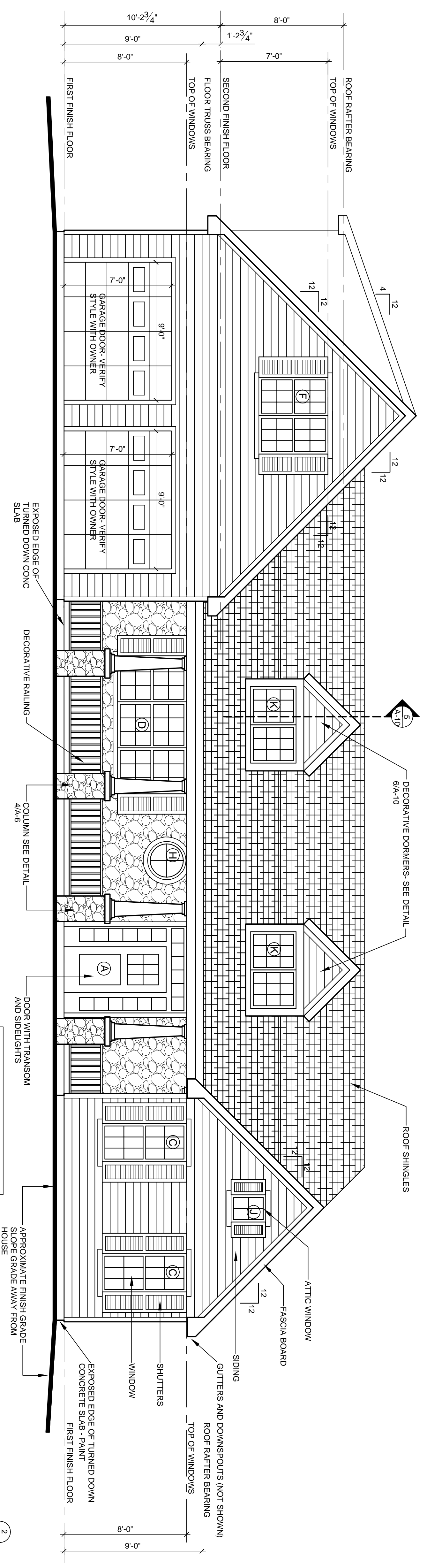

**1 FRONT ELEVATION**  
 SCALE: 1/4" = 1'-0"

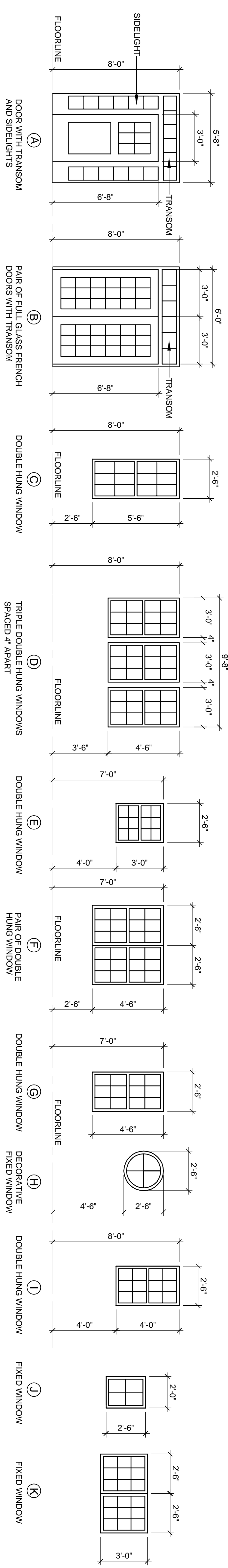

**3 EXTERIOR OPENING ELEVATIONS**  
 SCALE: 1/4" = 1'-0"

**4 COLUMN DETAIL**  
 SCALE: 3/8" = 1'-0"

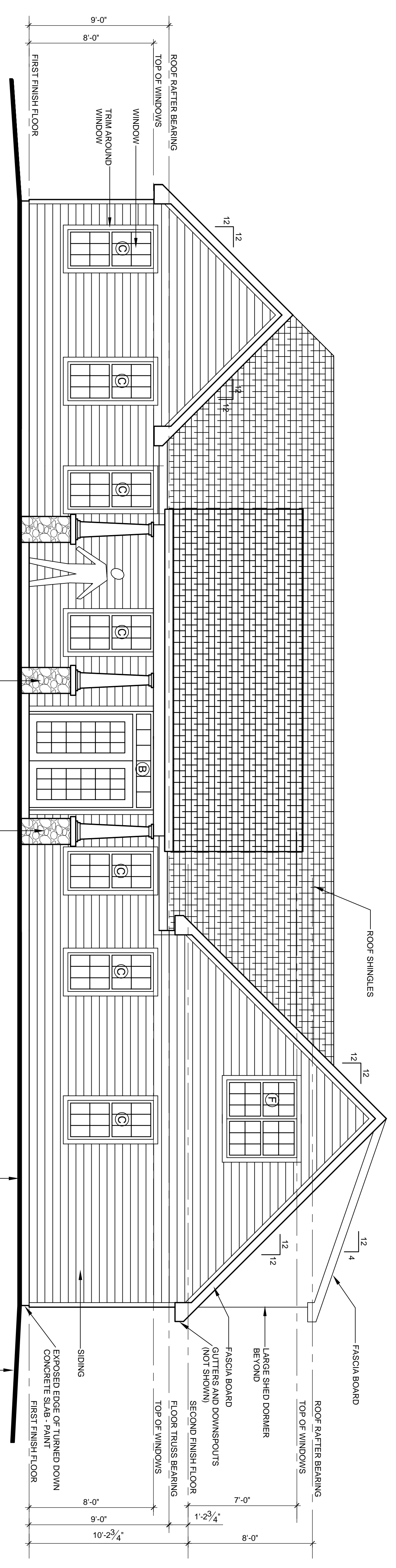
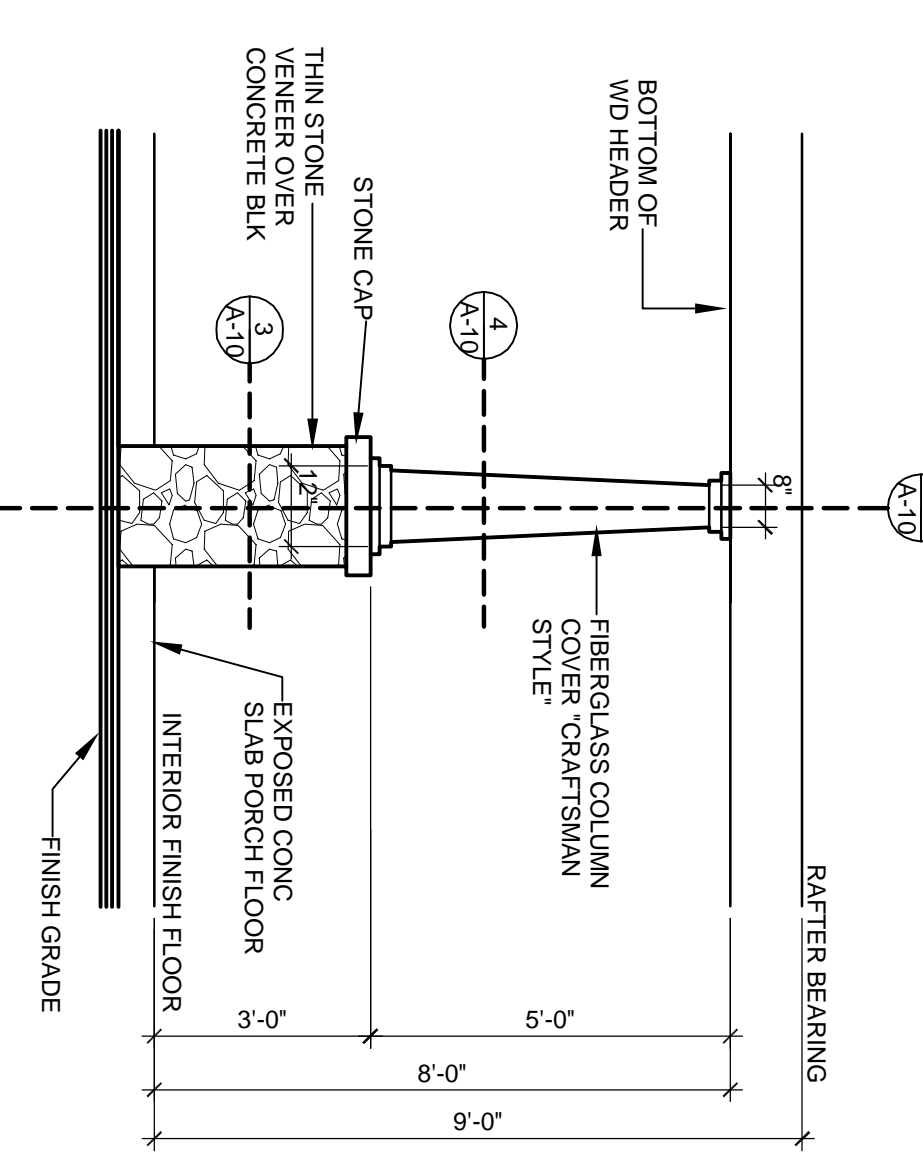

**2 REAR ELEVATION**  
 SCALE: 1/4" = 1'-0"

VERIFY WITH OWNER THE LOCATIONS OF THIN STONE VENEER AND SIDING. LOCATIONS MAY VARY AND WILL BE DETERMINED IN THE FIELD.

NOTE DIMENSIONS ARE NOMINAL. VERIFY ACTUAL DIMENSIONS AND ROUGH OPENING SIZES WITH MANUFACTURER

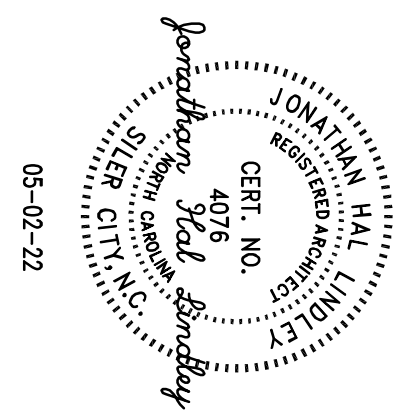
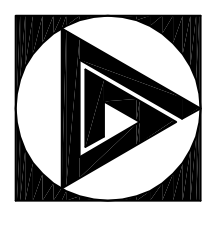

LEFT AND RIGHT SIDE ELEVATIONS

**NEW HOUSE FOR:  
MR & MRS RAMIREZ**

9382 OLD US 421  
BROADWAY, NORTH CAROLINA 27505

DATE : 05-02-2022  
PROJECT NO. 2022-15  
SCALE : SET DRAWING FOR SCALE  
DRAWN BY : JHL  
REVISION :

The drawing is the property of Lindley Architecture PLLC and is not to be copied or reproduced in any form without the written consent of Lindley Architecture PLLC.

SHEET **A-7** OF SHEETS

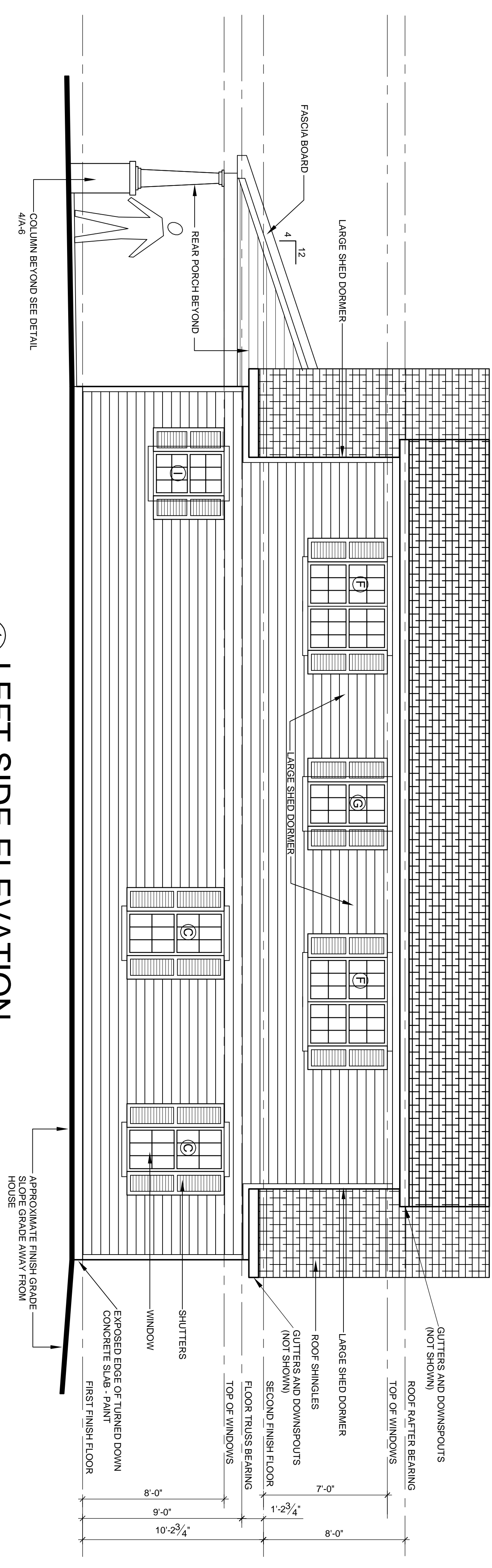

1 LEFT SIDE ELEVATION  
SCALE: 1/4" = 1'-0"

VERIFY WITH OWNER THE LOCATIONS OF THIN STONE VENEER AND SIDING LOCATIONS MAY VARY AND WILL BE DETERMINED IN THE FIELD

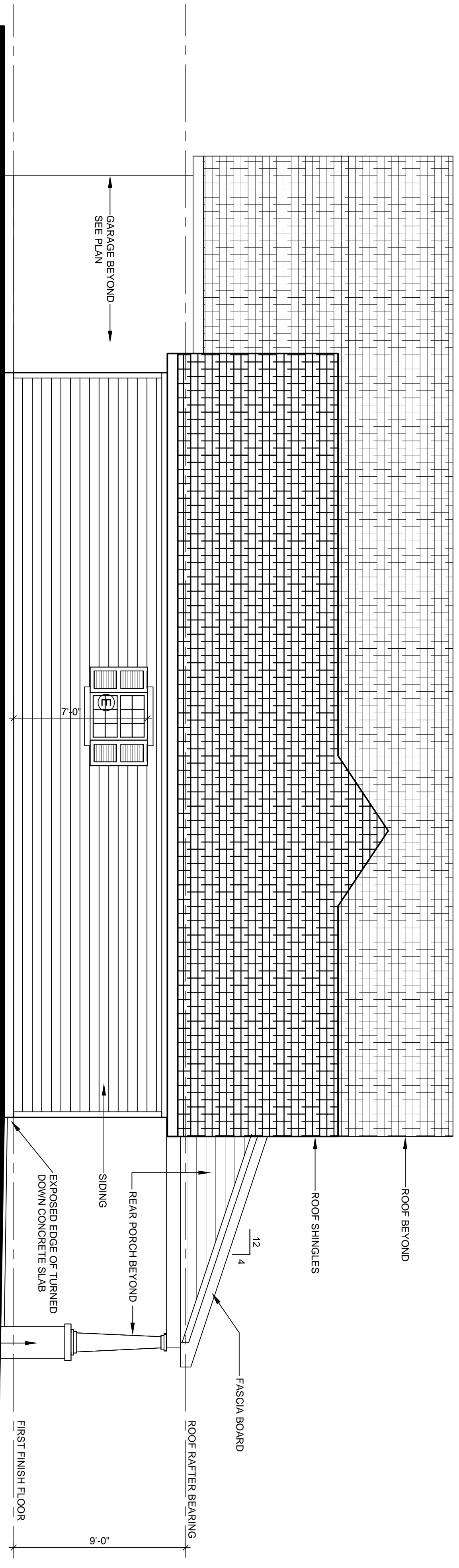

2 RIGHT SIDE ELEVATION  
SCALE: 1/4" = 1'-0"

VERIFY WITH OWNER THE LOCATIONS OF THIN STONE VENEER AND SIDING LOCATIONS MAY VARY AND WILL BE DETERMINED IN THE FIELD



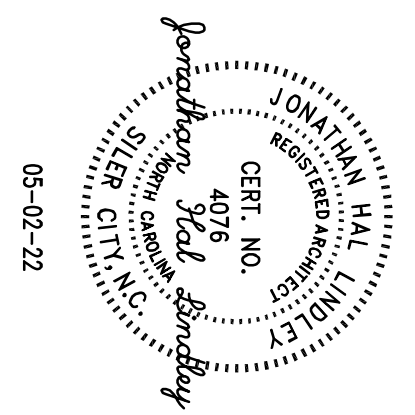
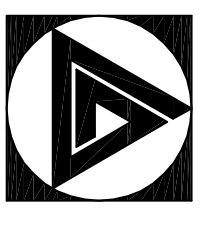

**SECTION THROUGH HOUSE**

**NEW HOUSE FOR:  
MR & MRS RAMIREZ**

9382 OLD US 421  
BROADWAY, NORTH CAROLINA 27505

DATE : 05-02-2022	REVISION :
PROJECT NO. 2022-15	
SCALE : SEE DRAWING FOR SCALE	
DRAWN BY : JHL	

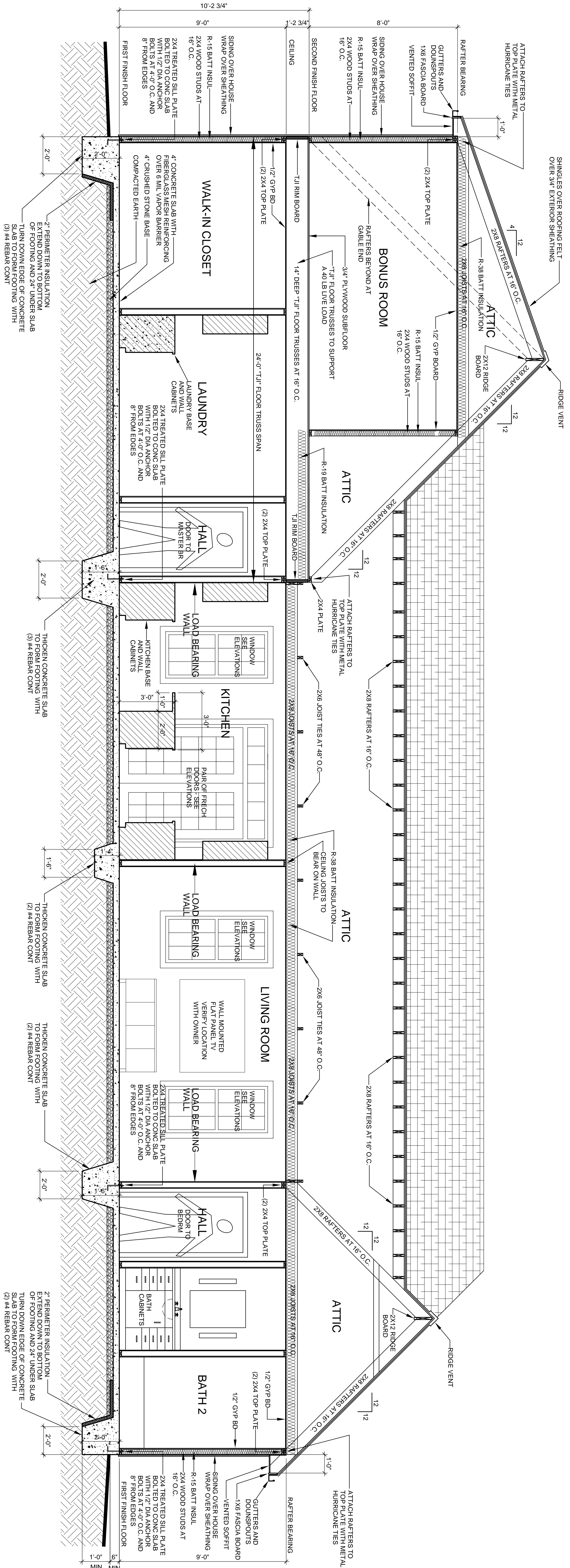

1 SECTION THROUGH HOUSE  
SCALE: 3/8" = 1'-0"

<p>DATE : 05-02-2022</p> <p>PROJECT NO. 2022-15</p> <p>SCALE : SEE DRAWING FOR SCALE</p> <p>DRAWN BY : JHL</p> <p>REVISION :</p>	<p><b>A-8</b></p> <p>OF SHEETS</p>
--	------------------------------------

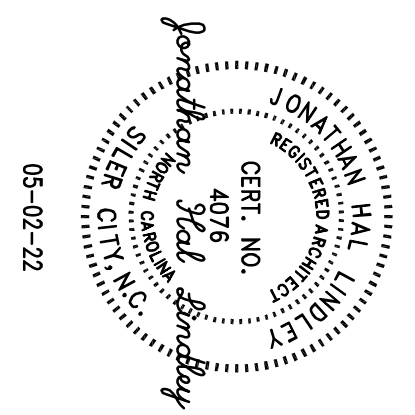
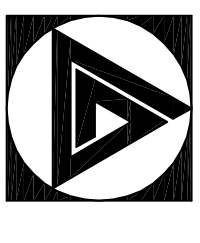

SECTIONS THROUGH GARAGE AND BONUS ROOM

**NEW HOUSE FOR:  
MR & MRS RAMIREZ**

9382 OLD US 421  
BROADWAY, NORTH CAROLINA 27505

DATE :	05-02-2022
PROJECT NO. :	2022-15
SCALE :	SEE DRAWING FOR SCALE
DRAWN BY :	JHL
REVISION :	
SHEET	A-9
OF	SHEETS

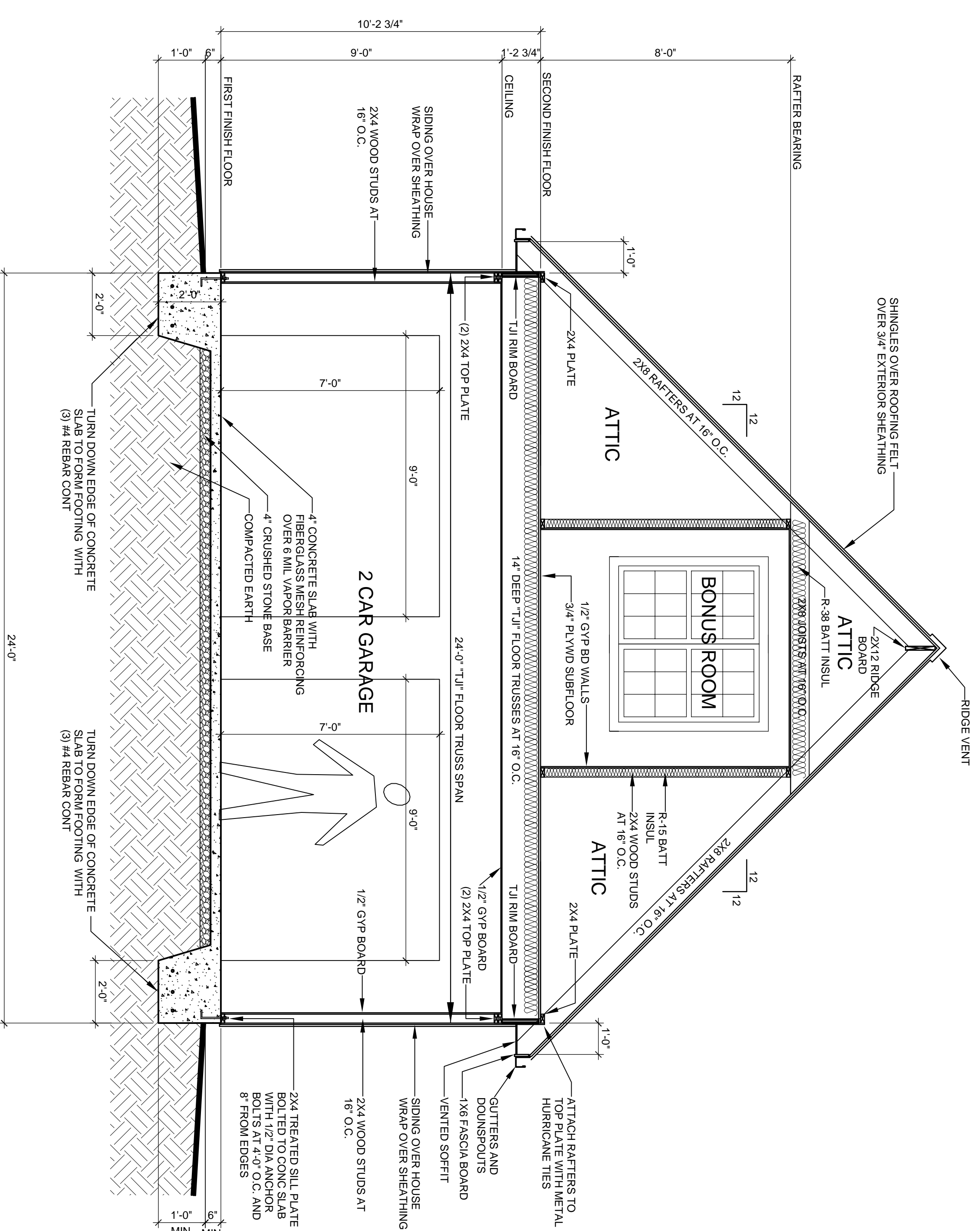

1 SECTION THROUGH GARAGE AND BONUS ROOM  
SCALE: 3/8" = 1'-0"

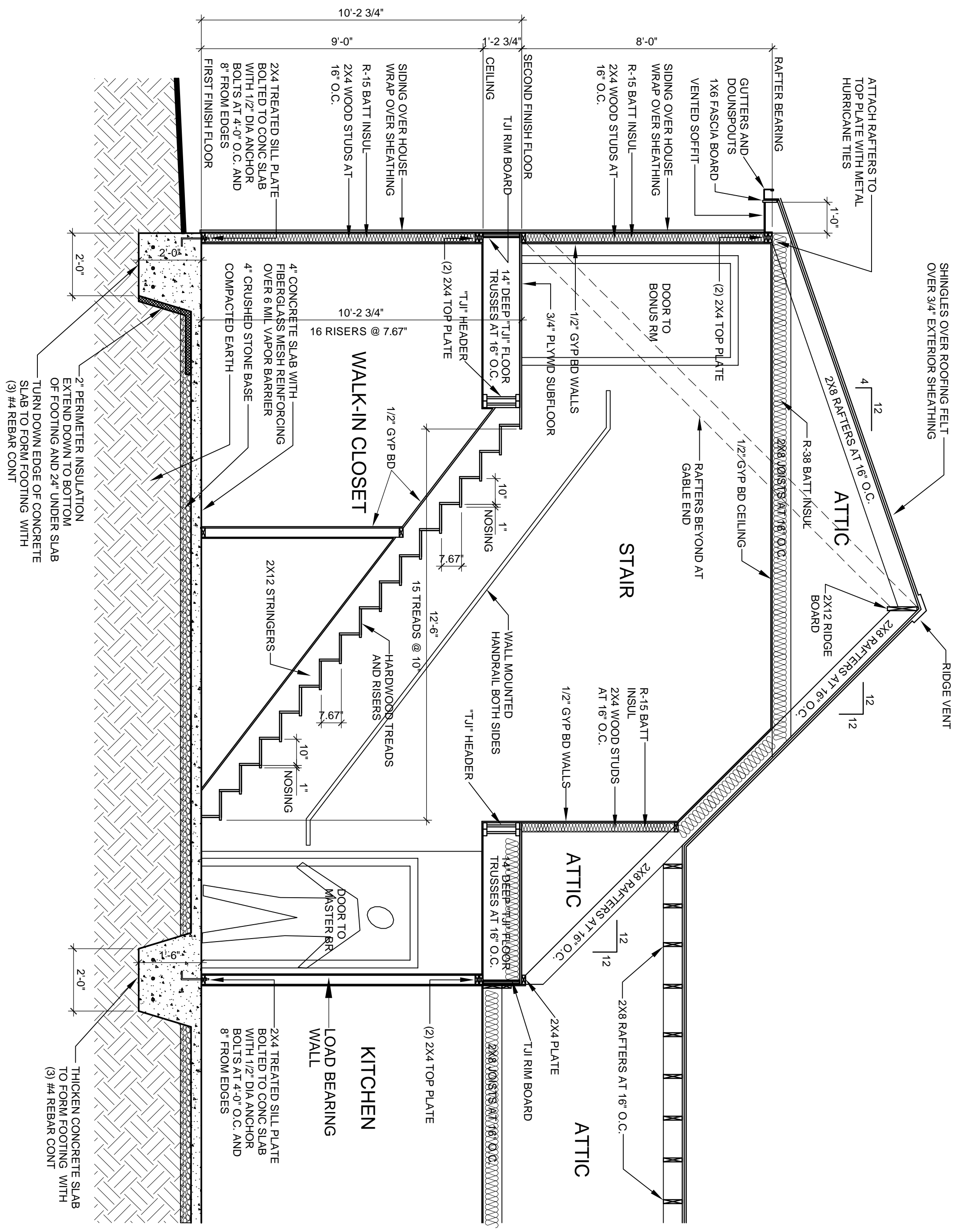

2 SECTION THROUGH GARAGE AND BONUS ROOM  
SCALE: 3/8" = 1'-0"

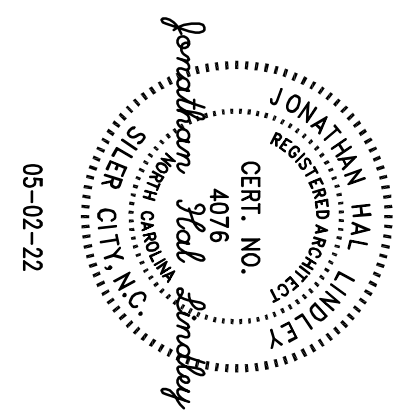
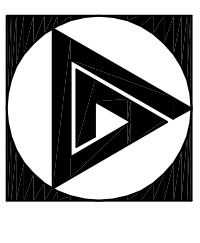

**SECTION THROUGH HOUSE AND PORCH DETAILS**

**NEW HOUSE FOR:  
MR & MRS RAMIREZ**

9382 OLD US 421  
BROADWAY, NORTH CAROLINA 27505

DATE : 05-02-2022  
PROJECT NO 2022-15  
SCALE : SEE DRAWING FOR SCALE  
DRAWN BY : JHL  
REVISION :

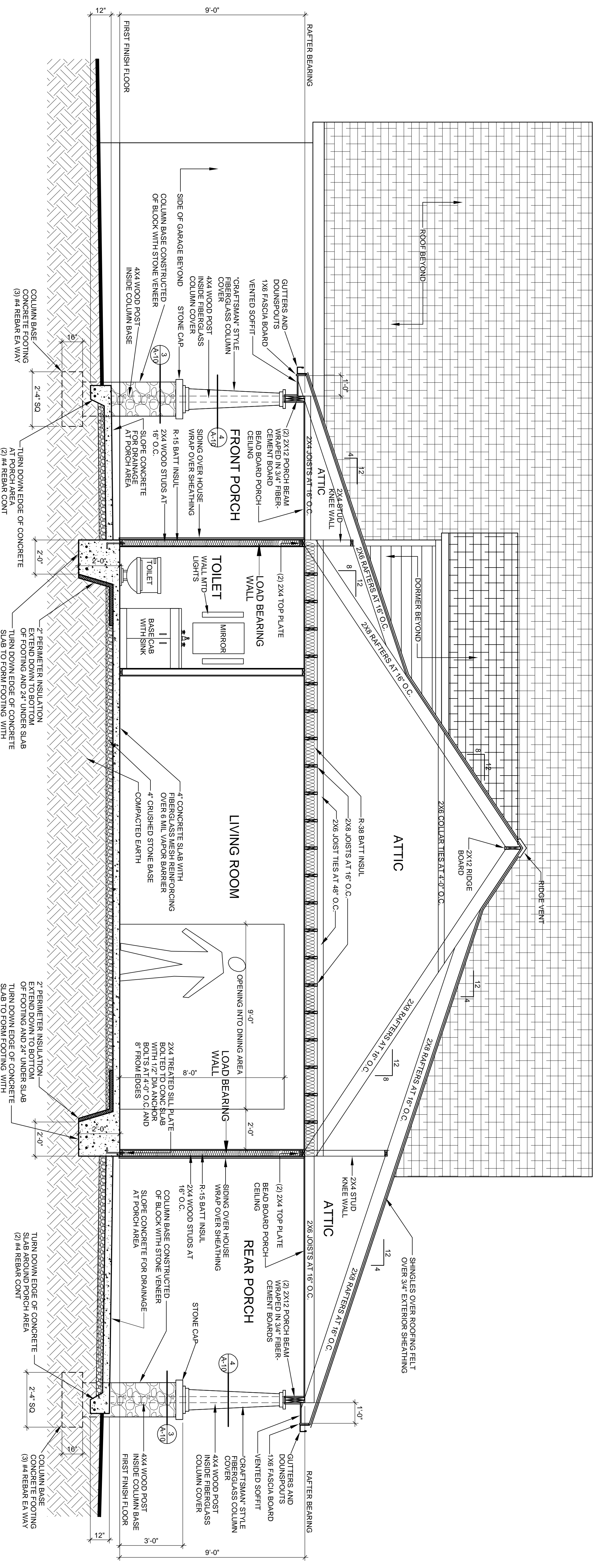

**1 SECTION THRU HOUSE**  
SCALE: 3/8" = 1'-0"

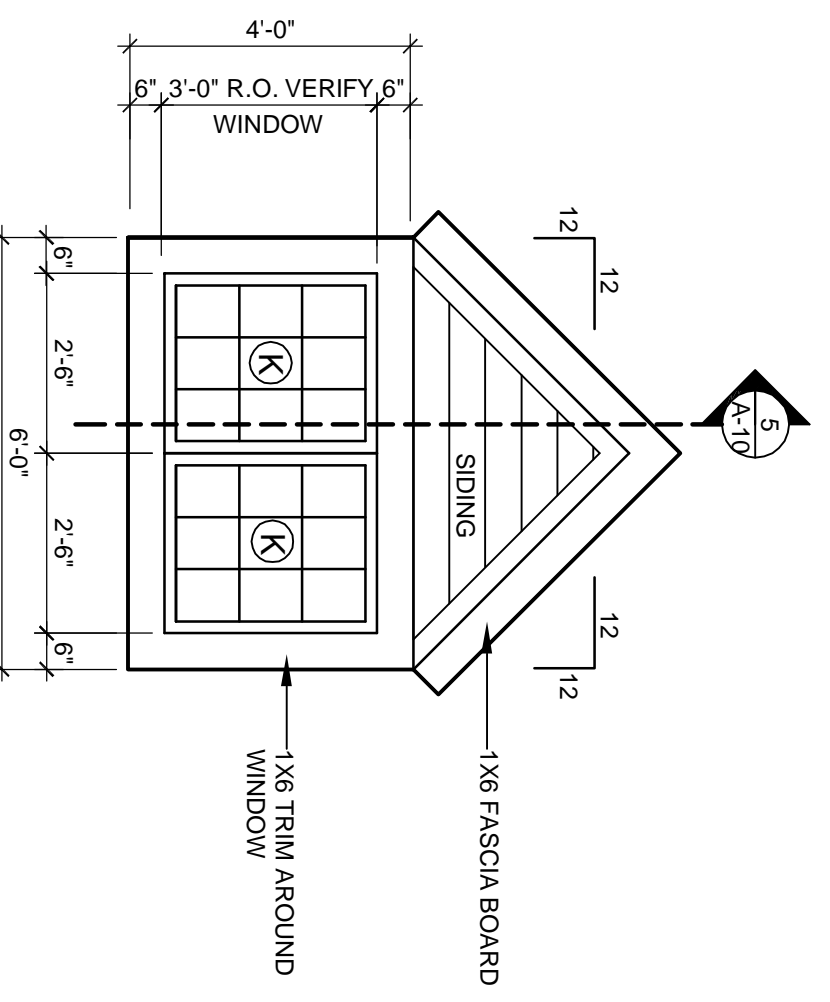

**6 DORMER ELEVATION**  
SCALE: 3/8" = 1'-0"

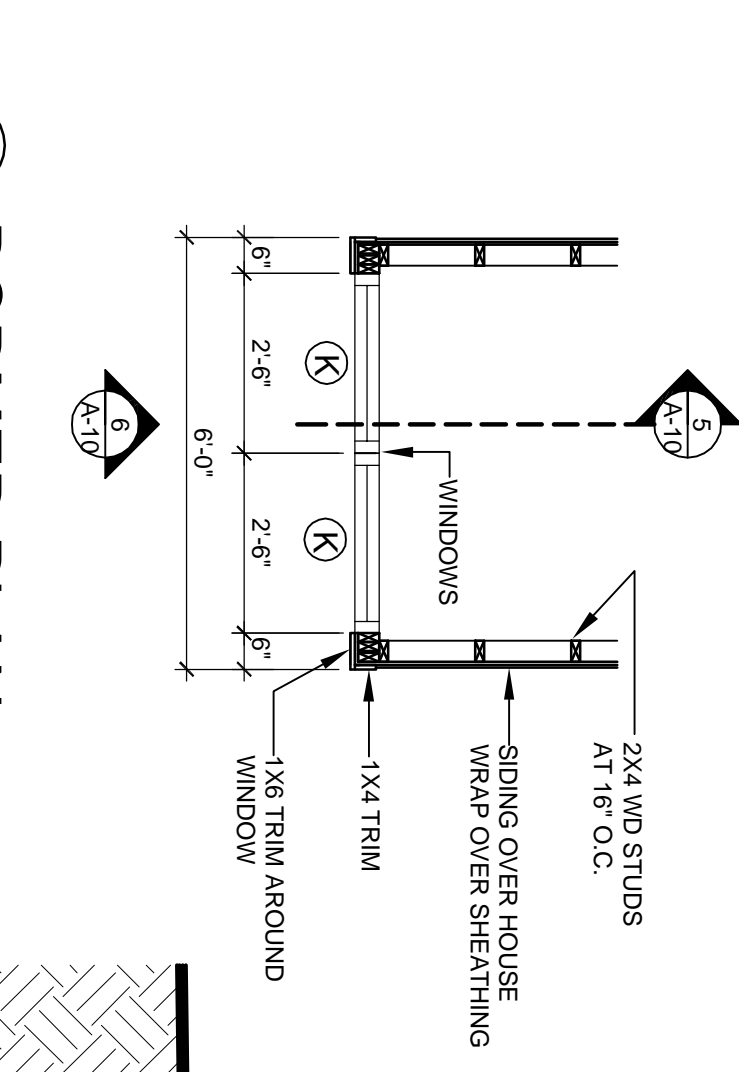

**7 DORMER PLAN**  
SCALE: 3/8" = 1'-0"

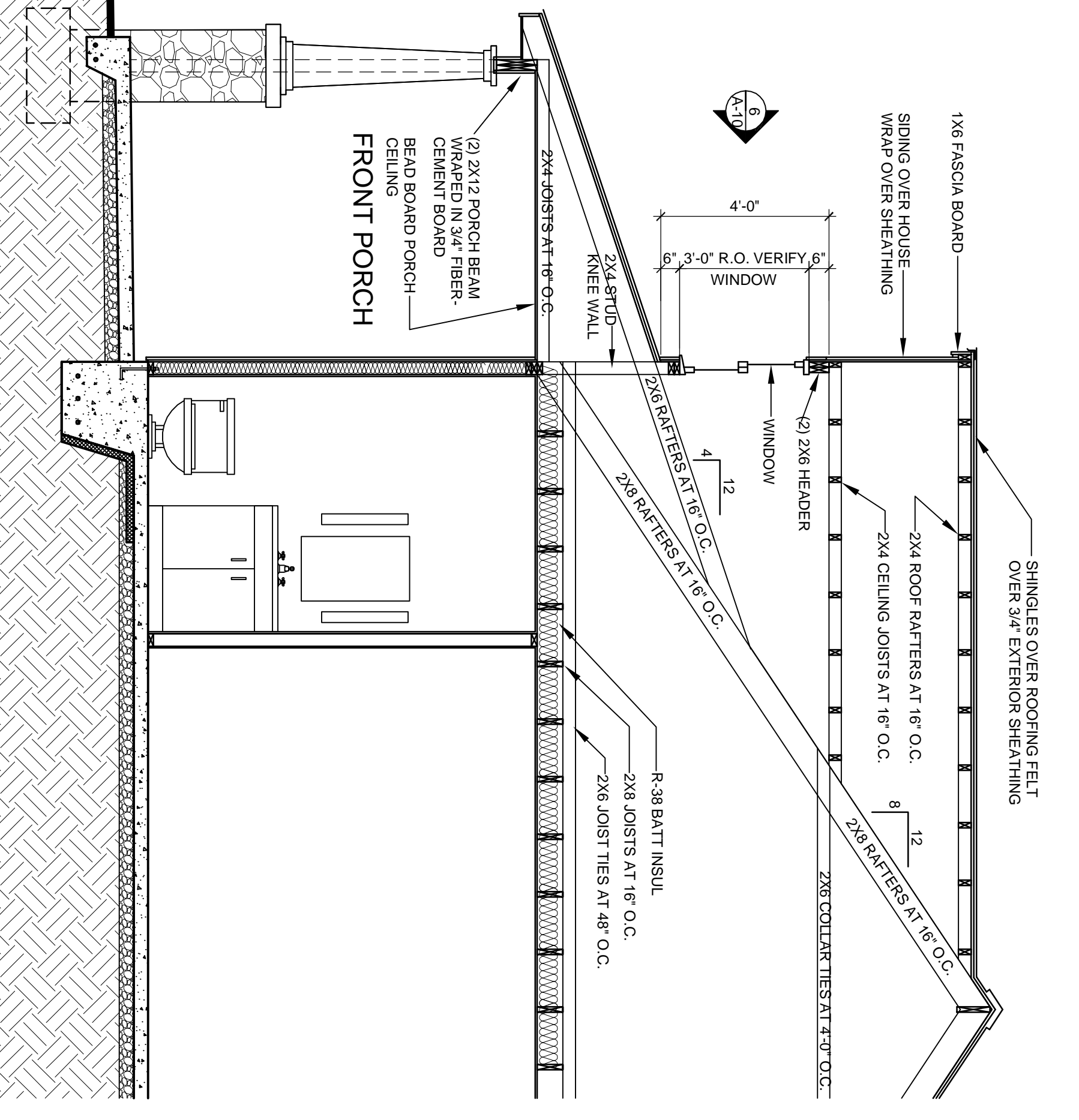

**5 SECTION AT DORMER**  
SCALE: 3/8" = 1'-0"

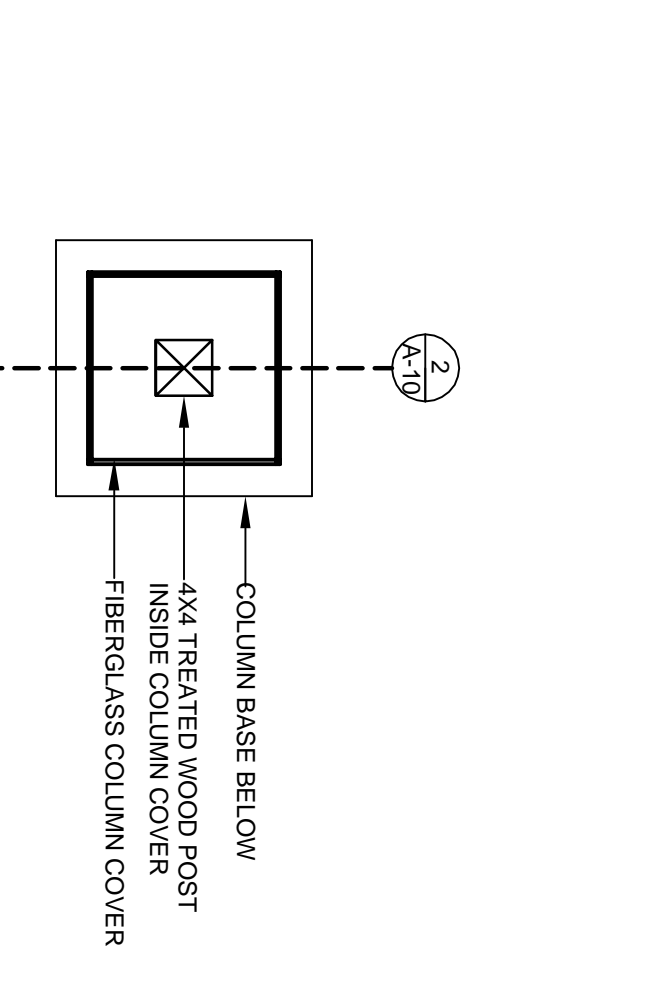

**4 PORCH POST PLAN DETAIL**  
SCALE: 1" = 1'-0"

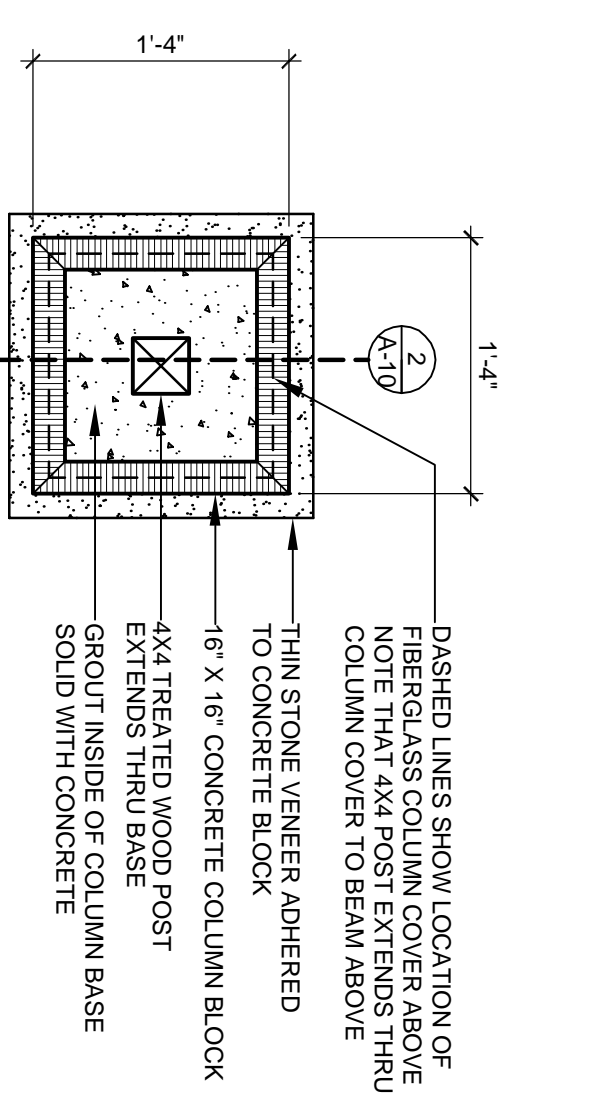

**3 COLUMN PLAN DETAIL**  
SCALE: 1" = 1'-0"

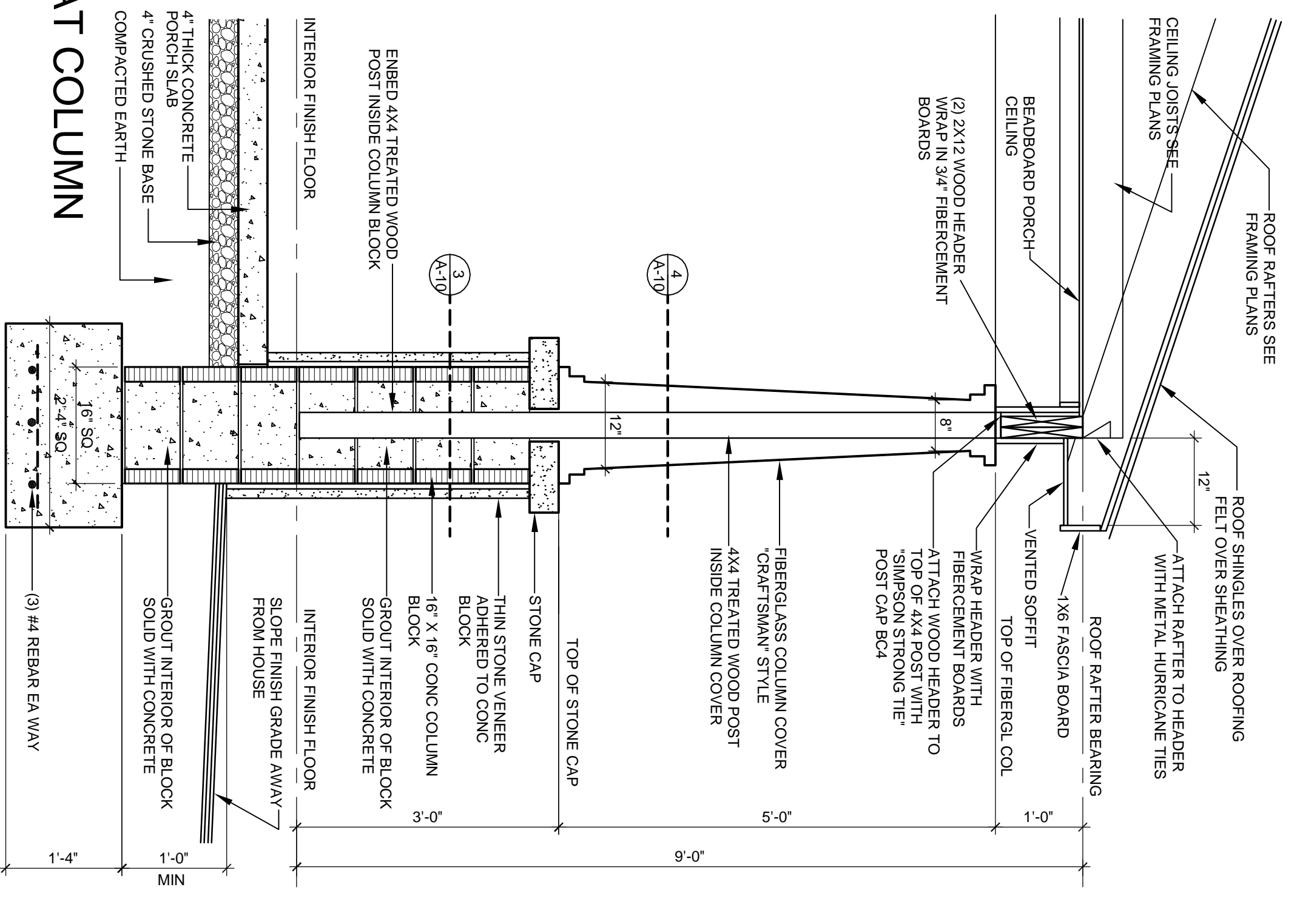

**2 SECTION AT COLUMN**  
SCALE: 3/4" = 1'-0"

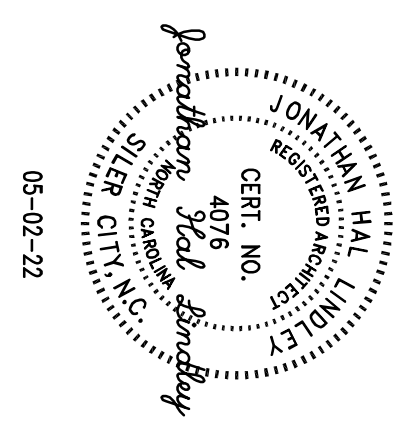

**FIRST AND SECOND FLOOR ELECTRICAL PLANS**

**NEW HOUSE FOR:  
MR & MRS RAMIREZ**

9382 OLD US 421  
BROADWAY, NORTH CAROLINA 27505

DATE : 05-02-2022  
PROJECT NO. 2022-15  
SCALE : SET DRAWING FOR SCALE  
DRAWN BY : JHL  
REVISION :

THIS DRAWING IS THE PROPERTY OF  
LINDLEY ARCHITECTURE PLLC AND IS NOT TO BE  
REPRODUCED OR TRANSMITTED IN ANY FORM OR  
BY ANY MEANS, ELECTRONIC OR MECHANICAL,  
INCLUDING PHOTOCOPYING, RECORDING, OR BY  
ANY INFORMATION STORAGE AND RETRIEVAL  
SYSTEMS, WITHOUT THE WRITTEN PERMISSION  
OF LINDLEY ARCHITECTURE PLLC.

SHEET **E-1** OF SHEETS

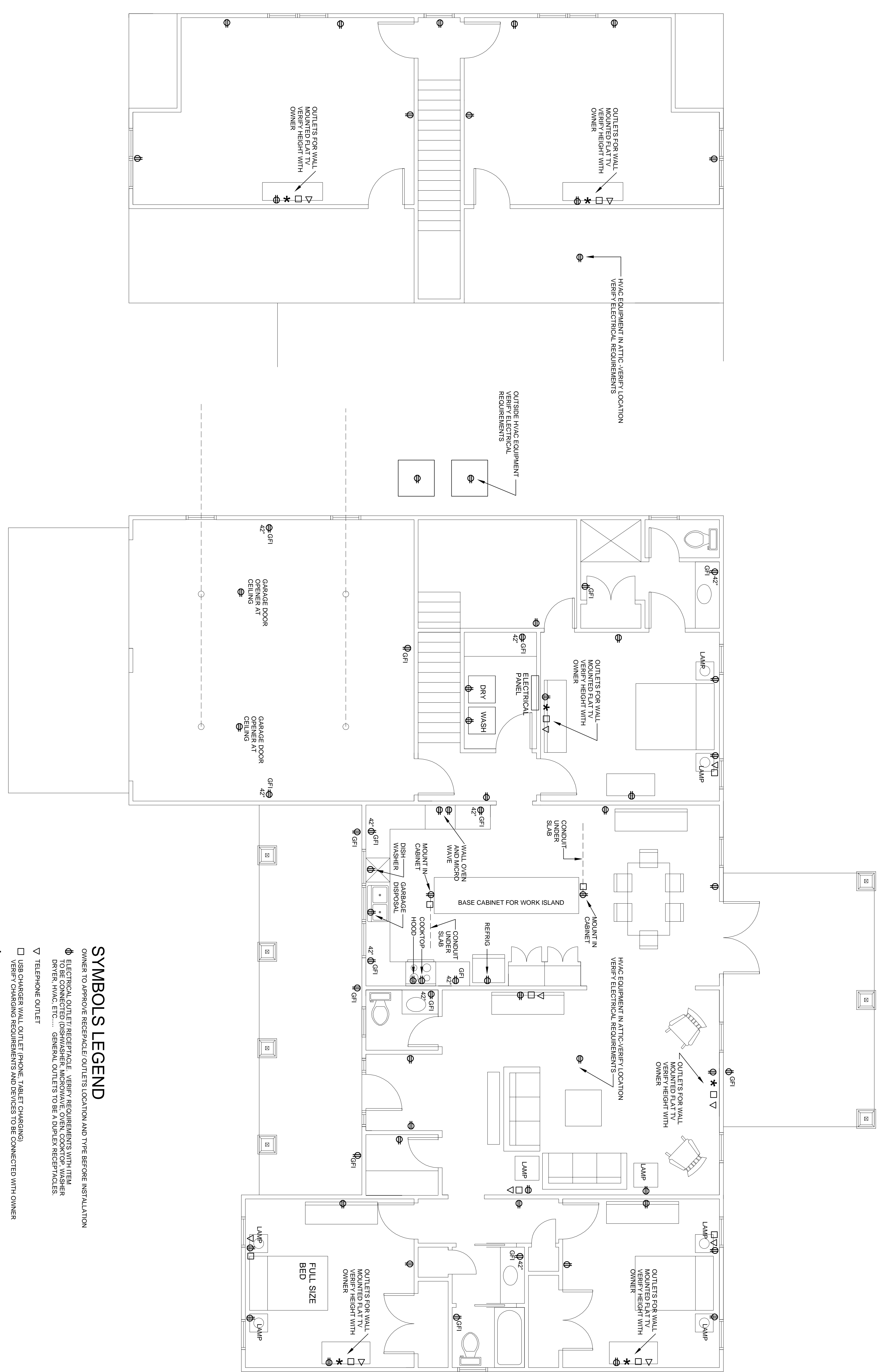

- SYMBOLS LEGEND**  
OWNER TO APPROVE RECEPTACLE/OUTLETS LOCATION AND TYPE BEFORE INSTALLATION
- ⊕ ELECTRICAL OUTLET/RECEPTACLE VERIFY REQUIREMENTS WITH ITEM TO BE CONNECTED (DISH/WASHER, MICROWAVE, OVEN, COOKTOP, WASHER DRYER, HVAC, ETC..... GENERAL OUTLETS TO BE A DUPLEX RECEPTACLES.
  - ▽ TELEPHONE OUTLET
  - USB CHARGER WALL OUTLET (PHONE, TABLET CHARGING) VERIFY CHARGING REQUIREMENTS AND DEVICES TO BE CONNECTED WITH OWNER
  - \* CABLE/SATELLITE TV OUTLET

**1** **FIRST FLOOR ELECTRICAL PLAN**  
SCALE: 1/4" = 1'-0"

PLAN IS DIAGRAMMATIC AND IS ONLY INTENDED TO SHOW THE GENERAL DESIGN INTENT AND MAY NEED TO BE MODIFIED TO MEET ACTUAL CONDITIONS AND REQUIREMENTS. THE SYSTEM IS NOT TO BE CONSIDERED AS A FINAL DESIGN. ALL WORK TO MEET LOCAL, STATE AND NATIONAL CODES AS REQUIRED.

**2** **SECOND FLOOR ELECTRICAL PLAN**  
SCALE: 1/4" = 1'-0"

**E-1**

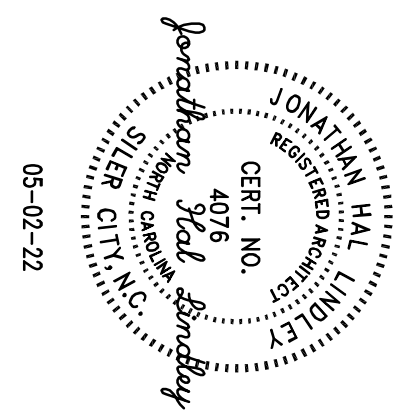
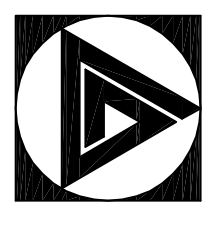

**FIRST AND SECOND FLOOR LIGHTING PLANS**

**NEW HOUSE FOR:  
MR & MRS RAMIREZ**

9382 OLD US 421  
BROADWAY, NORTH CAROLINA 27505

DATE :	05-02-2022
PROJECT NO. :	2022-15
SCALE :	SEE DRAWING FOR SCALE
DRAWN BY :	JHL
REVISION :	
THIS DRAWING IS THE PROPERTY OF LINDLEY ARCHITECTURE PLLC AND IS NOT TO BE COPIED OR REPRODUCED IN ANY MANNER WITHOUT THE WRITTEN CONSENT OF LINDLEY ARCHITECTURE PLLC.	
SHEET	<b>E-2</b>
OF	SHEETS

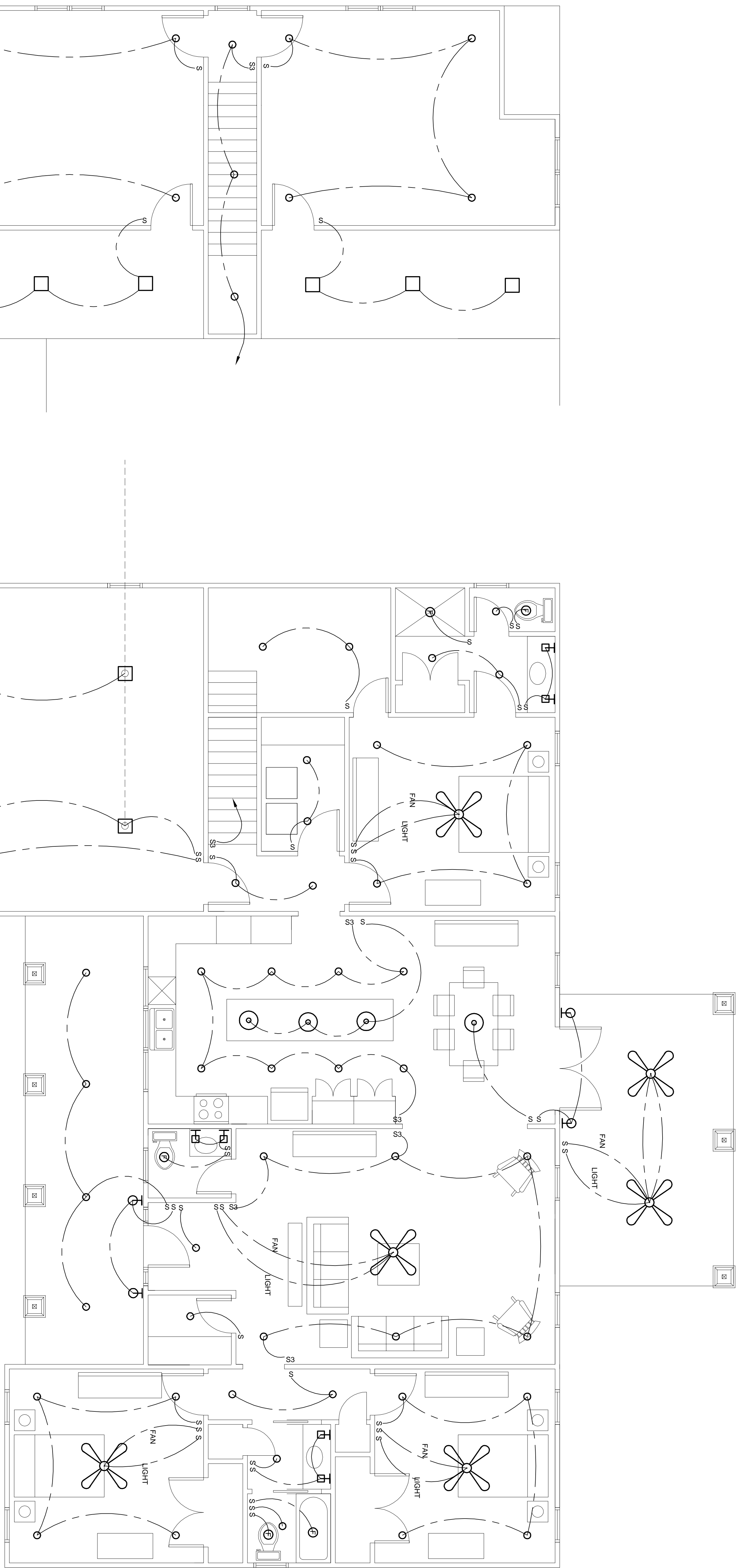

**SYMBOLS LEGEND**  
OWNER TO APPROVE FIXTURES BEFORE INSTALLATION

- RECESSED LED DIMMABLE DOWN LIGHT FIXTURE - FOR OUTSIDE LOCATIONS USE CERTIFIED FOR OUTDOOR USE
- ⊕ CEILING EXHAUST FAN
- ⊞ WALL MOUNTED VANITY LIGHT
- SURFACE MOUNTED CEILING LIGHT FIXTURE
- ⊕ CEILING FAN - FOR OUTSIDE LOCATIONS USE CEILING FAN CERTIFIED FOR OUTDOOR USE
- ⊞ EXTERIOR WALL MOUNTED LIGHT FIXTURE
- ⊙ PENDANT HUNG LIGHT FIXTURE
- S WALL LIGHT SWITCH - DIMMABLE
- SS 3 WAY WALL LIGHT SWITCH - DIMMABLE
- LIGHT SWITCH WIRING

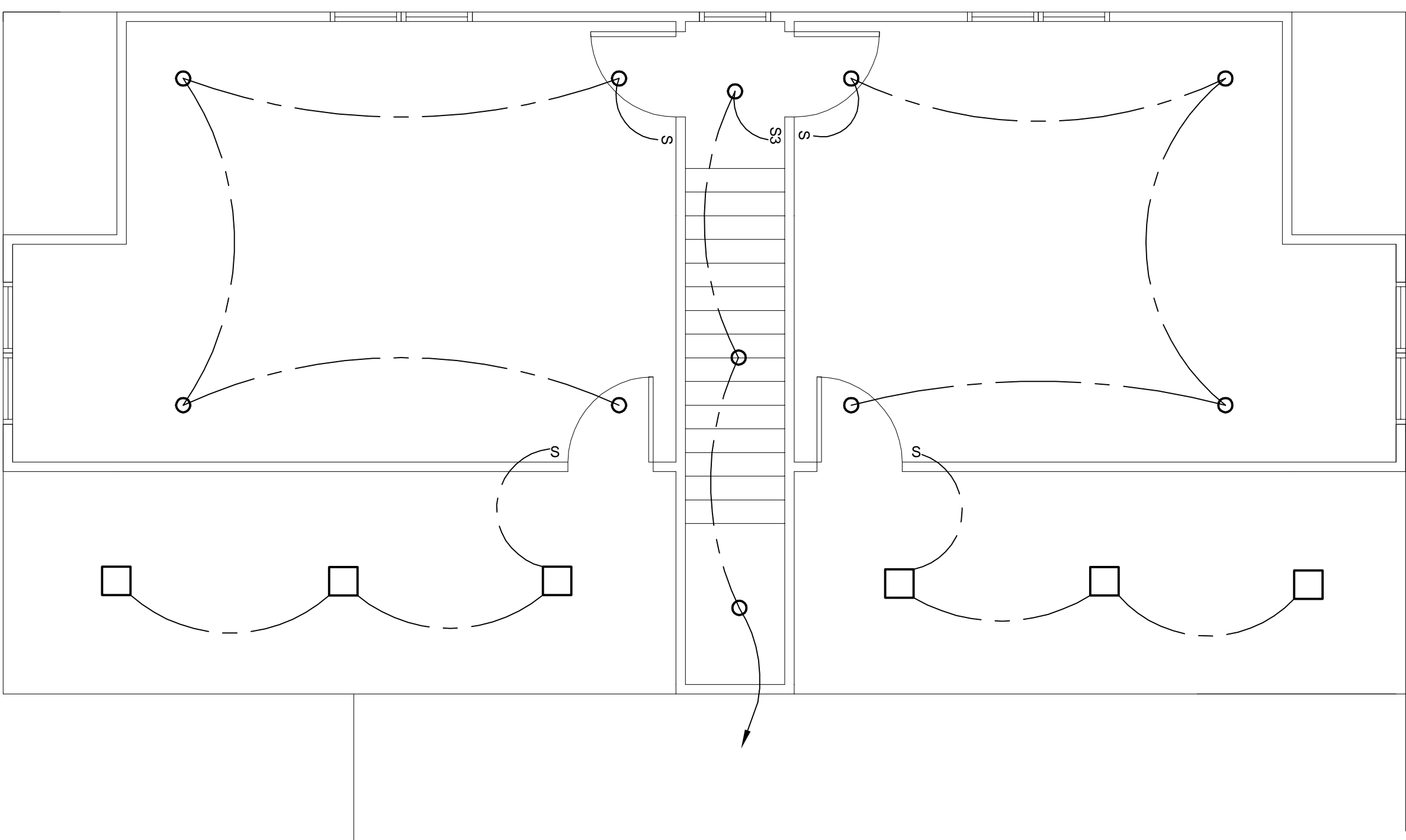

**FIRST FLOOR LIGHTING PLAN**  
SCALE: 1/4" = 1'-0"

PLAN IS DIAGRAMMATIC AND IS ONLY INTENDED TO SHOW THE GENERAL DESIGN INTENT AND MAY NEED TO BE MODIFIED TO MEET ACTUAL CONDITIONS AND REQUIREMENTS. THE SYSTEM SHALL BE DESIGNED AND INSTALLED BY A LICENSED ELECTRICAL CONTRACTOR REGISTERED IN THE STATE OF NORTH CAROLINA. ALL WORK TO MEET LOCAL, STATE AND NATIONAL CODES AS REQUIRED.

**SECOND FLOOR LIGHTING PLAN**  
SCALE: 1/4" = 1'-0"

E-2