

# Harnett County Department of Public Health

## Improvement Permit

A building permit cannot be issued with only an Improvement Permit

ISSUED TO: Triple A Homes, Inc. PROPERTY LOCATION: 52 Royal Ella Ct. (Christian Light Rd. - SR)  
 SUBDIVISION Prince Place LOT # 14

NEW  REPAIR  EXPANSION  Site Improvements required prior to Construction Authorization Issuance:

Type of Structure: 48x53 sfd, 4 beds 4 baths

Proposed Wastewater System Type: 10in Large Diameter Pic

Projected Daily Flow: 480 GPD

Number of bedrooms: 4 Number of Occupants: 8 max

Basement  Yes  No

Pump Required:  Yes  No  May be required based on final location and elevations of facilities

Type of Water Supply:  Community  Public  Well Distance from well NA feet

Permit conditions: \_\_\_\_\_ Permit valid for:  Five years  No expiration

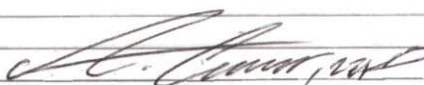
Authorized State Agent:  Date: 04/21/2022 SEE ATTACHED SITE SKETCH

The issuance of this permit by the Health Department in no way guarantees the issuance of other permits. The permit holder is responsible for checking with appropriate governing bodies in meeting their requirements. This site is subject to revocation if the site plan, plat, or the intended use changes. The Improvement Permit shall not be affected by a change in ownership of the site. This permit is subject to compliance with the provisions of the Laws and Rules for Sewage Treatment and Disposal and to conditions of this permit.

## Construction Authorization

(Required for Building Permit)

The construction and installation requirements of Rules .1950, .1952, .1954, .1955, .1956, .1957, .1958, and .1959 are incorporated by references into this permit and shall be met. Systems shall be installed in accordance with the attached system layout.

ISSUED TO: Triple A Homes, Inc. PROPERTY LOCATION: 52 Royal Ella Ct. (Christian Light Rd. - S)  
 SUBDIVISION Prince Place LOT # 14

Facility Type: 48x53 sfd, 4 beds 4 baths  New  Expansion  Repair

Basement?  Yes  No Basement Fixtures?  Yes  No

Type of Wastewater System\*\* 10in Larger Diameter Pipe (Initial) Wastewater Flow: 480 GPD  
 (See note below, if applicable  10in Larger Diameter Pipe (Repair))

Installation Requirements/Conditions

Septic Tank Size <u>1000</u> gallons	Number of trenches <u>4</u>	Exact length of each trench <u>160</u> feet	Trench Spacing: <u>6</u> Feet on Center
Pump Tank Size _____ gallons	Trenches shall be installed on contour at a	Maximum Trench Depth of: <u>18</u> inches	Soil Cover: <u>6</u> inches
	(Trench bottoms shall be level to +/-1/4" in all directions)	(Maximum soil cover shall not exceed 36" above the trench bottom)	

Pump Requirements: \_\_\_\_\_ ft. TDH vs. \_\_\_\_\_ GPM

Aggregate Depth: NA inches below pipe  
NA inches above pipe

Conditions: Gravity to D-Box Equal Distribution; Proposal by Mitchell Enviro. NA inches total

**WATER LINES (INCLUDING IRRIGATION) MUST BE 10FT. FROM ANY PART OF SEPTIC SYSTEM OR REPAIR AREA.**  
**NO UTILITIES ALLOWED IN INITIAL OR REPAIR DRAIN FIELD AREA.**

\*\*If applicable: I understand the system type specified is different from the type specified on the application. I accept the specifications of this permit.

Owner/Legal Representative Signature: \_\_\_\_\_ Date: \_\_\_\_\_

This Construction Authorization is subject to revocation if the site plan, plat, or the intended use changes. The Construction Authorization shall not be transferred when there is a change in ownership of the site. This Construction Authorization is subject to compliance with the provisions of the Laws and Rules for Sewage Treatment and Disposal and to the conditions of this permit. SEE ATTACHED SITE SKETCH

Authorized State Agent:  Date: 04/22/2022  
Andrew Collins Construction Authorization Expiration Date: 04/22/2027

Application # SFD2204-0023

## Harnett County Department of Public Health Site Sketch

Property Location: 52 Royal Ella Ct. (Christian Light Rd. - SR 1412)

Issued To: Triple A Homes, Inc. Subdivision Prince Place Lot # 14

Authorized State Agent: *Andrew Collins* Date: 04/21/2022  
ANDREW COLLINS

\* PROPOSAL BY MITCHELL ENVIRONMENTAL

\* 10 IN W/12 DIAMETER PIPE [SEE SPECS] OPEN SPACE

\* GRAVITY TO D-BOX EQUAL DISTRIBUTION REQUIRED

\* 18 IN TRENCH (WIDE), 6 FT ON CENTER, 18 IN MAX [SEE SPECS]

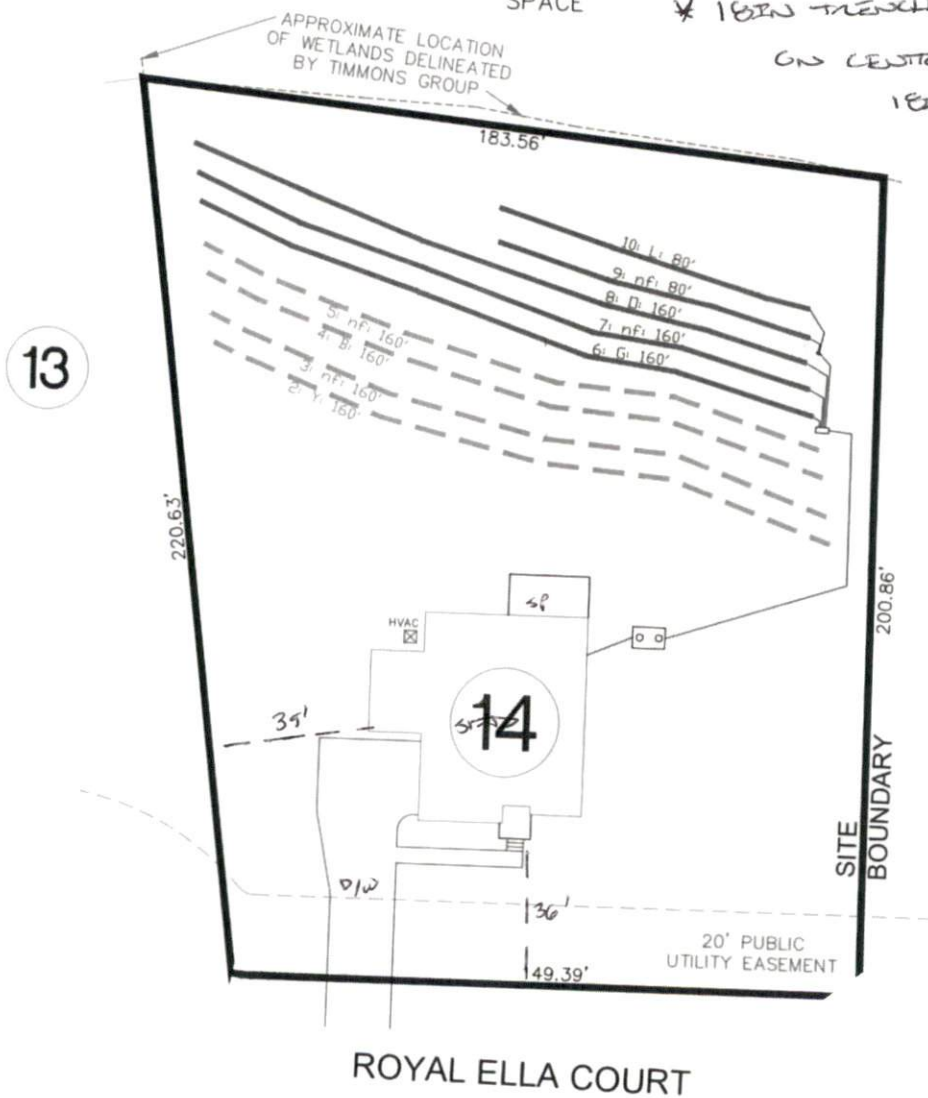

This drawing is for illustrative purposes only. System installation must meet all pertinent laws, rules, and regulations.

**Mitchell Environmental, P.A.**

**SEPTIC SYSTEM DESIGN**

**for**

**PRINCE PLACE SUBDIVISION- LOT 14**

**Fuquay-Varina, Harnett County, North Carolina**

**Submitted to:**

Harnett County Health Department  
307 Cornelius Harnett Blvd.  
Lillington, NC 27546

**Prepared for:**

Triple A Homes, Inc.  
PO Box 1117  
Holly Springs, North Carolina 27540

**Prepared by:**

Scott Mitchell, PE, LSS  
Adam Aycock, EI

**DATE: March 31, 2022**  
**PROJECT NO.: 4721**

4-Bedroom  
 LTAR: 0.3 gpd/ft<sup>2</sup>  
 Initial: Gravity-to-10" Large Diameter  
 Pipe utilizing lines 6-10 (640')  
 Repair: Gravity-to-10" Large Diameter  
 Pipe utilizing lines 2-5 (640')

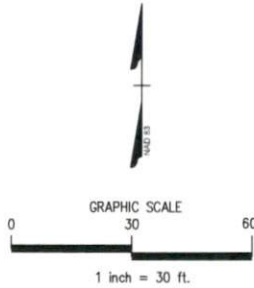
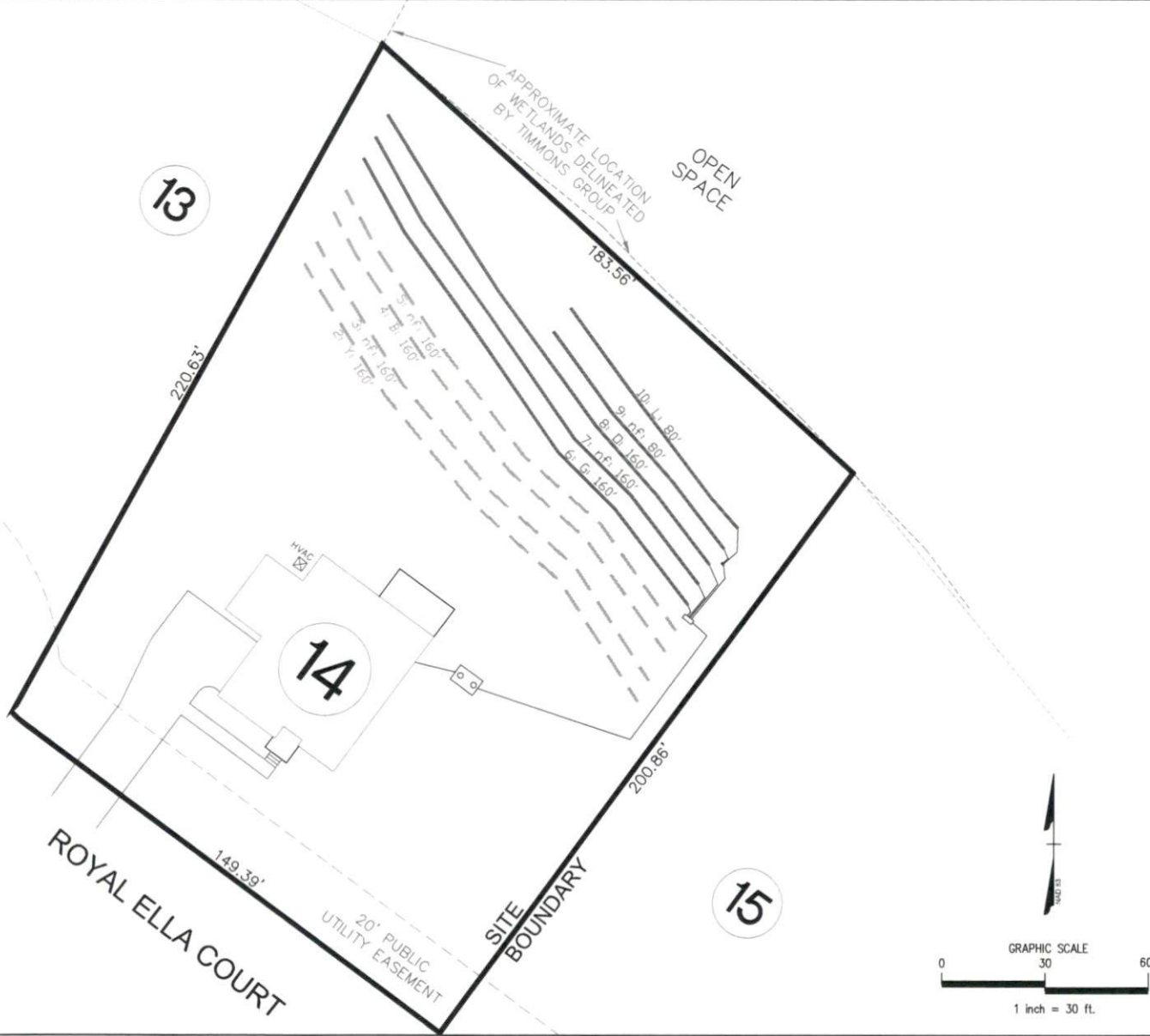

<b>MITCHELL ENVIRONMENTAL, PA</b> C-2917		<b>DATE</b> March 31, 2022		<b>SHEET NUMBER</b> 1 of 5	
<b>PREPARED FOR:</b> Tipe A Thomas PO Box 1117 Holly Springs, NC 27540		<b>REVISION NO.</b> Original Submittal		<b>Prinice Place</b> Lot 14 Overrall Septic	
<b>DATE:</b> March 31, 2022		Revision 1			
<b>DESIGNER CONTACT:</b> ADAM AYCOCK, E		Revision 2			
<b>DRAWN BY:</b> ADAM AYCOCK, E		Revision 3			
		Master SA			

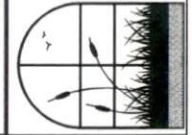



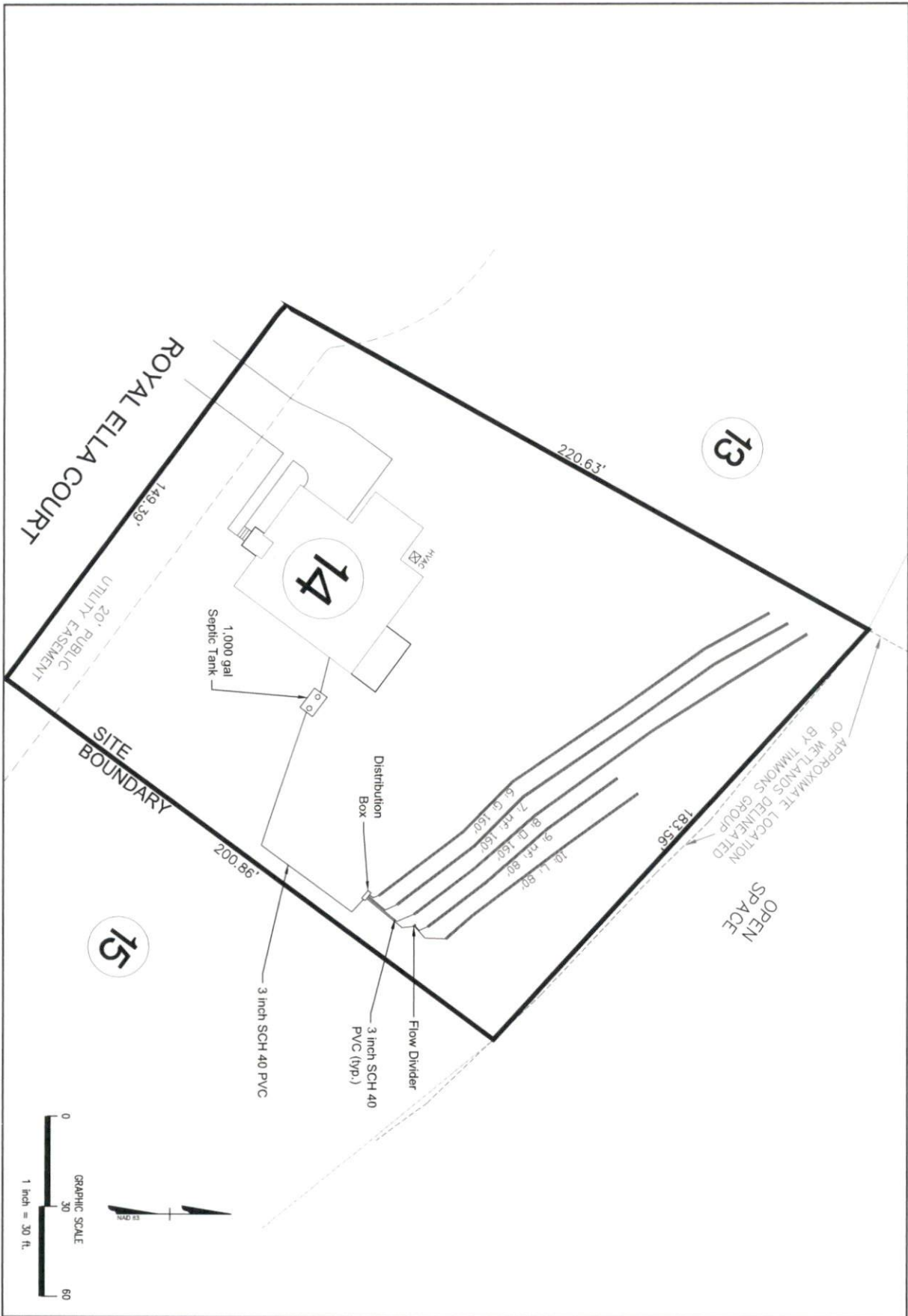

**MITCHELL ENVIRONMENTAL, PA**  
 C-2911  
 1501 LAKESTONE VILLAGE LANE  
 SUITE 205  
 FUQUAY VARINA, NC 27526

PREPARED FOR: Triple A Homes  
 PO Box 1117  
 Holly Springs, NC 27540

DATE: March 31, 2022

DESIGNER CONTACT:  
 ADAM AYCOCK, EI

DRAWN BY:  
 ADAM AYCOCK, EI

REVISION NO.	DATE
Original Submittal	March 31, 2022
Revision 1	-----
Revision 2	-----
Revision 3	-----
Master Set	-----

**SHEET NUMBER**

2 of 5

Prince Place  
 Lot 14  
 Initial Nitrification Field

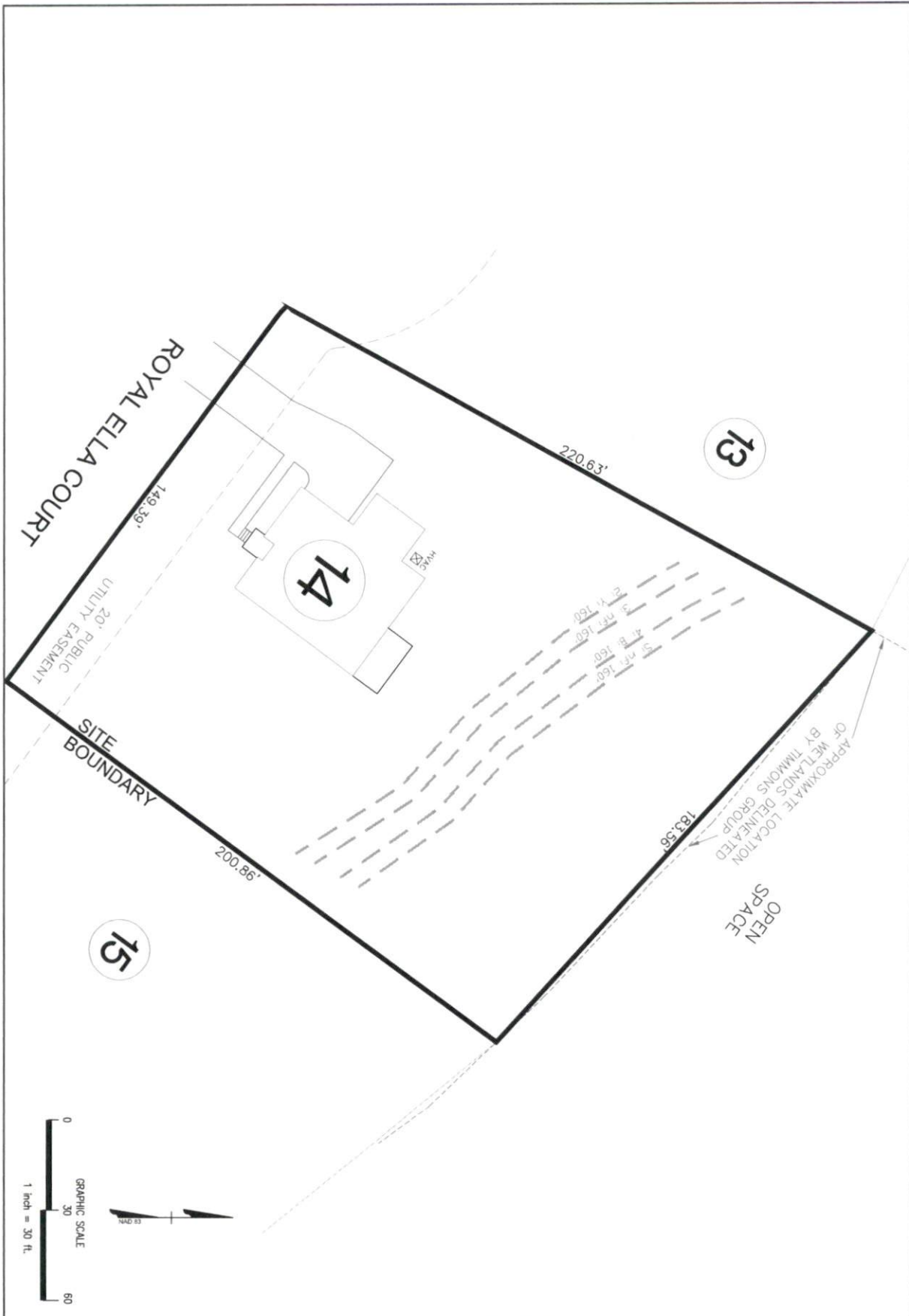

**MITCHELL ENVIRONMENTAL, PA**  
 C-2911  
 1501 LAKESTONE VILLAGE LANE  
 SUITE 205  
 FUQUAY VARINA, NC 27526

PREPARED FOR: Triple A Homes  
 PO Box 1117  
 Holly Springs, NC 27540  
 DATE: March 31, 2022  
 DESIGNER CONTACT:  
 ADAM AYCOCK, EI  
 DRAWN BY:  
 ADAM AYCOCK, EI

REVISION NO.	DATE
Original Submittal	March 31, 2022
Revision 1	-----
Revision 2	-----
Revision 3	-----
Master Set	-----

**SHEET NUMBER**  
 3 of 5  
 Prince Place  
 Lot 14  
 Repair Nitrification Field



Property Description:

LOT#14 PRINCE PLACE PH 1 MAP#2021-372

Harnett County GIS

PID: 050633 0026 14

PIN: 0633-76-8922.000

REID:

Subdivision:

Taxable Acreage: 0.820 AC ac

Caclulated Acreage: 0.82 ac

Account Number: 1500038152

Owners: TRIPLE A HOMES INC

Owner Address : PO BOX 1117 HOLLY SPRINGS, NC 27540

Property Address: 52 ROYAL ELLA CT FUQUAY-VARINA, NC 27526

City, State, Zip: FUQUAY-VARINA, NC, 27526

Building Count: 0

Township Code: 08

Fire Tax District: Northwest Harnett

Parcel Building Value: Unavailable

Parcel Outbuilding Value : Unavailable

Parcel Land Value : Unavailable

Parcel Special Land Value : Unavailable

Total Value : Unavailable

Parcel Deferred Value : Unavailable

Total Assessed Value : Unavailable

Neighborhood: 00821

Actual Year Built:

TotalAcutalAreaHeated: Sq/Ft

Sale Month and Year: 10 / 2021

Sale Price: \$715000

Deed Book & Page: 4055-0910

Deed Date: 1633392000000

Plat Book & Page: 2021-372

Instrument Type: WD

Vacant or Improved:

QualifiedCode: A

Transfer or Split: T

Within 1mi of Agriculture District: Yes

Prior Building Value: Unavailable

Prior Outbuilding Value : Unavailable

Prior Land Value : Unavailable

Prior Special Land Value : Unavailable

Prior Deferred Value : Unavailable

Prior Assessed Value : Unavailable



# STB - 345 - Top Seam

Approval Date: 12 - 09 - 99

Liquid Capacity 1007 Gallons

Non Traffic Rated

Reinforcing Schedule: # 3 Grade 60 Rebar

4500 PSI Concrete w/ State Approved Structural Fiber

Est. Weight: 8,200 lbs.

Manufactured By:

# GARNERS

Septic Tanks, Inc.

Eddie Garner, President

919-718-5181

121 Stanton Hill Road

Carthage, NC 28327

Fax 919-775-2229

Eddie@garnersseptic tanks.com

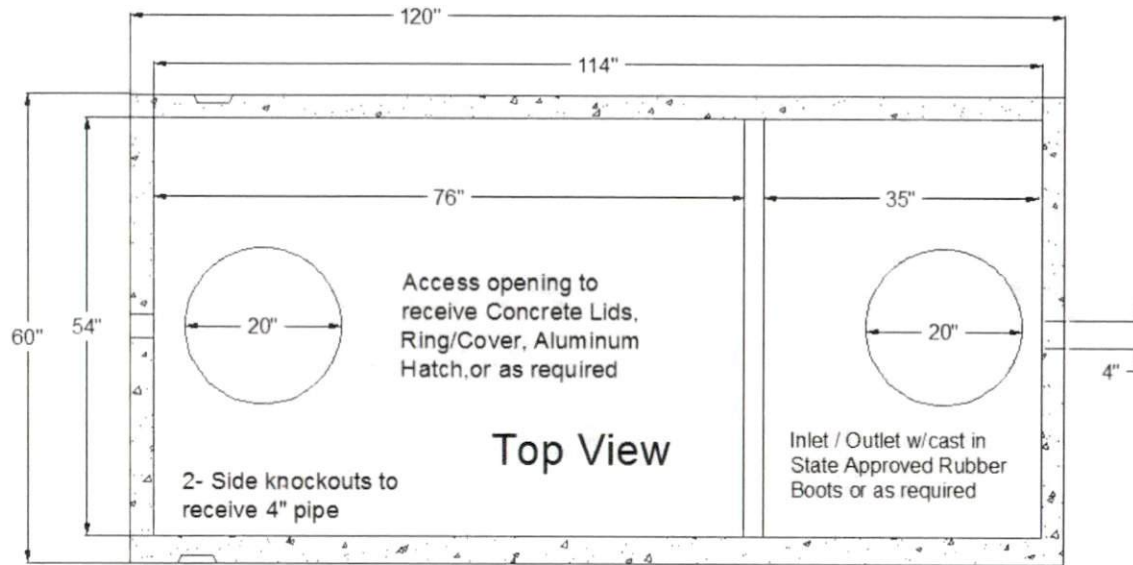

Top View

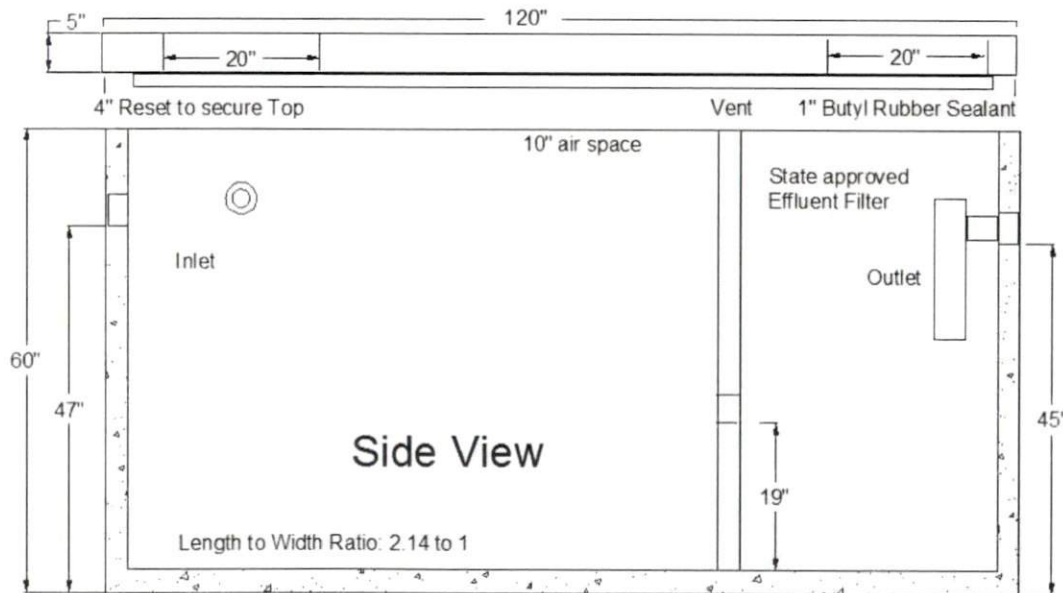

Side View

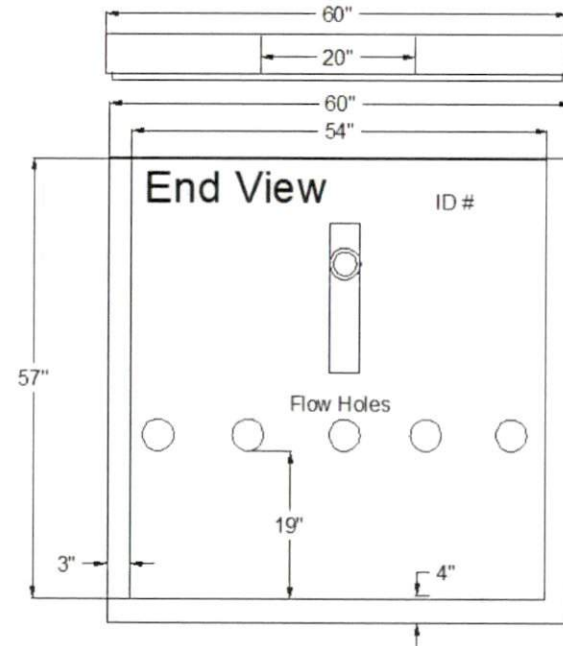

End View





**PL-68 Filter and Tee**

PL-68 is much more than just an effluent filter. The housing can also be used as an inlet baffle (tee) or an outlet baffle. The housing is designed to accept Polylok's snap in gas deflector to deflect gas bubbles away from the tee and to keep the solids in the tank.

**Features:**

- Offers 68 linear feet of 1/16" filter slots, which significantly extends time between cleaning.
- Accepts 3/4" PVC handle.
- Locks in any 360° position when used with PL-68 Tee.
- PL-68 Housing can be used as an inlet or outlet tee.
- Gasket prevents bypass.

**PL-68 Installation:**

Ideal for residential waste flows up to 800 gallons per day (GPD). Easily installs in any new or existing 4" outlet tee.

1. Locate the outlet of the septic tank.
2. Remove the tank cover and pump tank if necessary.
3. Glue the filter housing to the outlet pipe, or use a Polylok Extend & Lok if not enough pipe exists.
4. Insert the PL-68 filter into tee.
5. Replace and secure the septic tank cover.

**PL-68 Maintenance:**

The PL-68 Effluent Filter will operate efficiently for several years under normal conditions before requiring cleaning. It is recommended that the filter be cleaned every time the tank is pumped, or at least every three years.

1. Do not use plumbing when filter is removed.
2. Pull PL-68 out of the tee.
3. Hose off filter over the septic tank. Make sure all solids fall back into septic tank.
4. Insert filter back into tee/housing.

**Related Products:**

PL-68 Filter Concrete Baffle  
 Extend & Lok™



Extend & Lok™  
 Easily installs into existing tanks.



Spacer Bushing  
 4" SCHD 40 to SDR 35



Spacer Bushing  
 4" SCHD 40 to 110mm Pipe



2" Extender

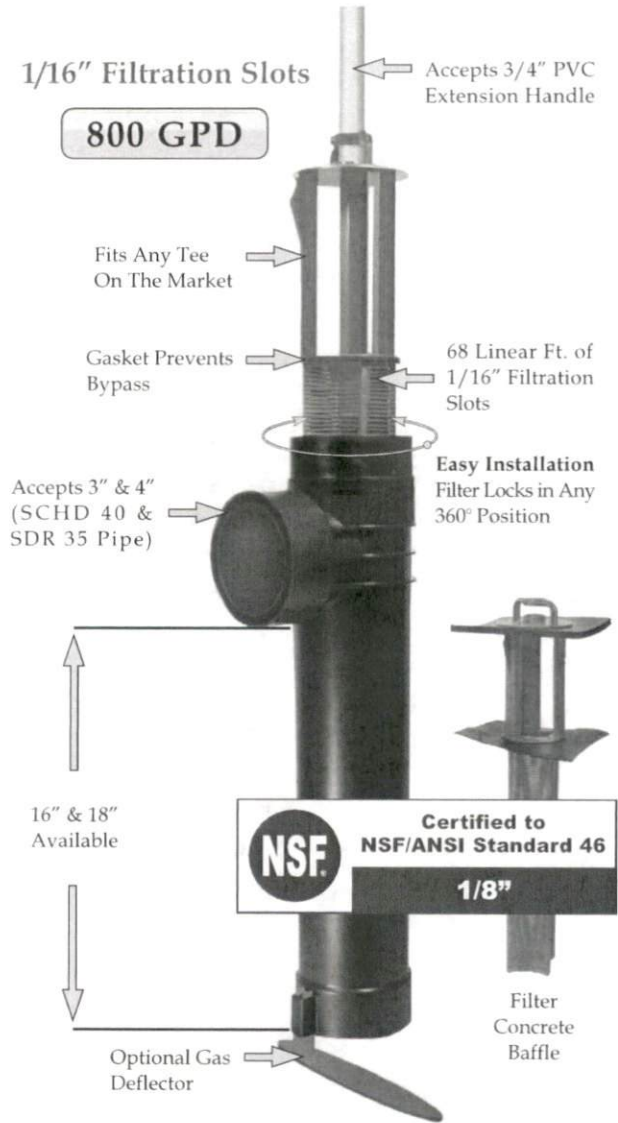

**POLYLOK FLOW CONTROLLER**  
**PART NO. 3051**  
**MATERIAL - ABS**

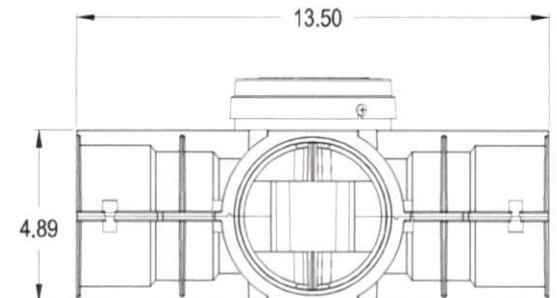
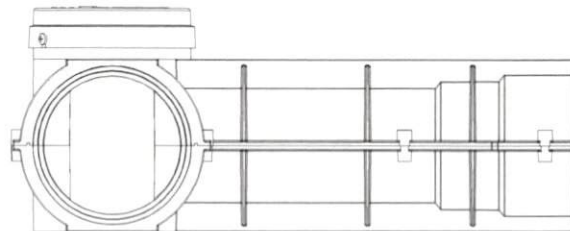
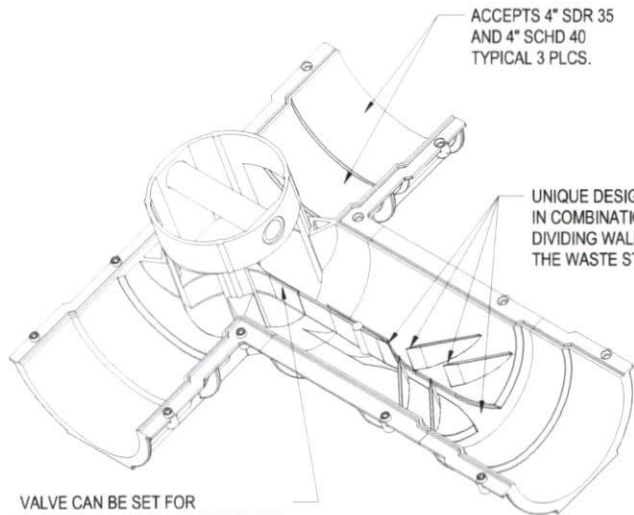
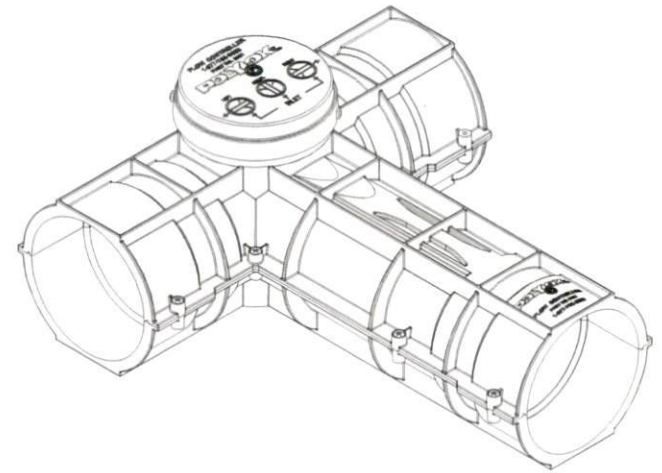
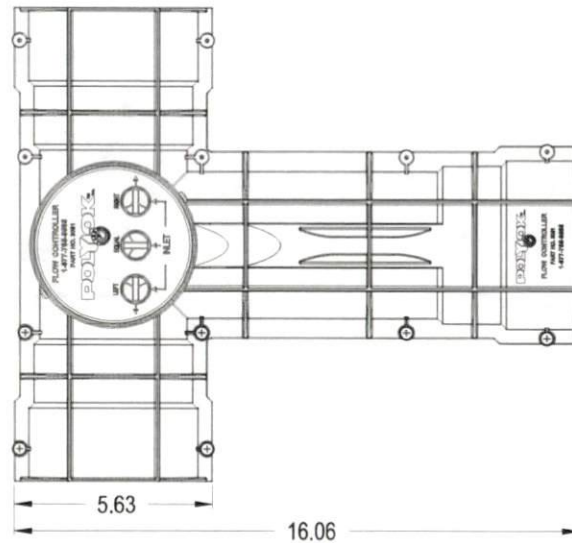



# Crumpler's No-Rock™ Fabric Wrapped Large Diameter (LDP) Septic Pipe

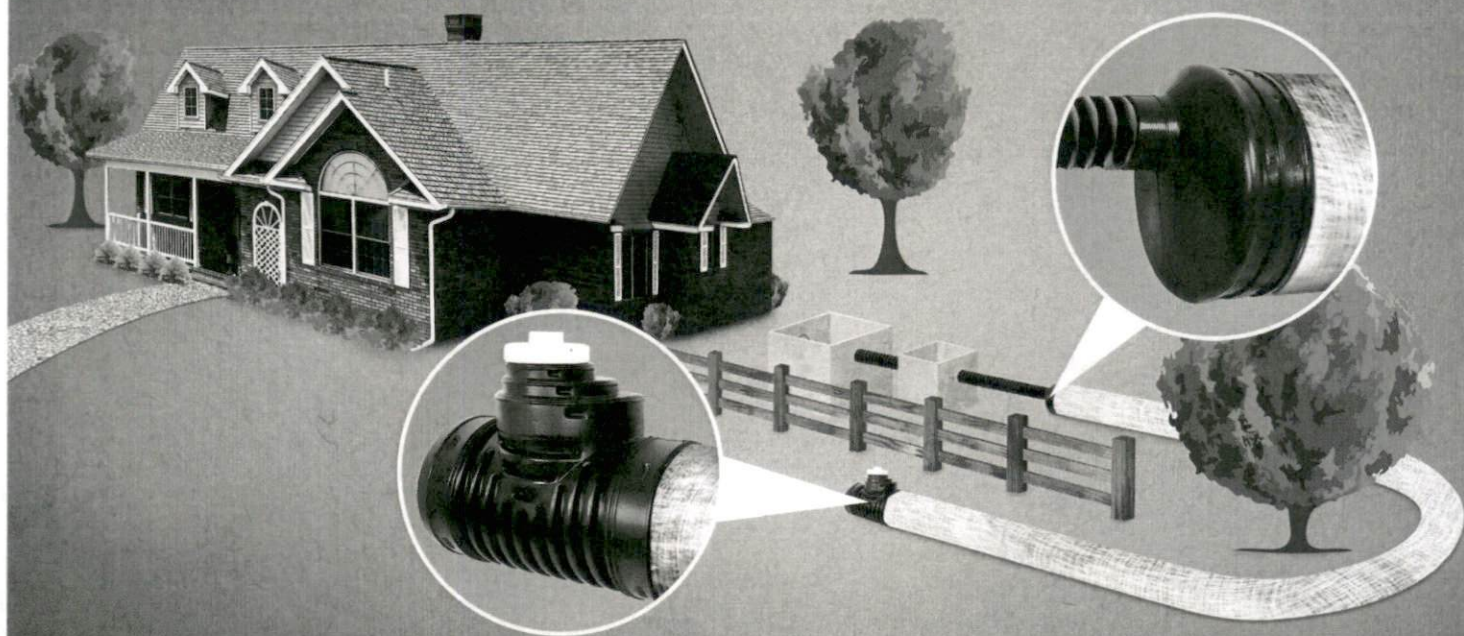

## ***Crumpler Plastic Pipe, Inc.***

***Manufacturers of Corrugated Plastic Drainage Pipe***

Phone 910-525-4046 / (800) 334-5071

Post Office Box 2068

Roseboro, North Carolina 28382

Web Site: [www.cpp-pipe.com](http://www.cpp-pipe.com)







# Crumpler's No-Rock™ Fabric Wrapped Large Diameter (LDP) Septic Pipe



**Blind Tee's**

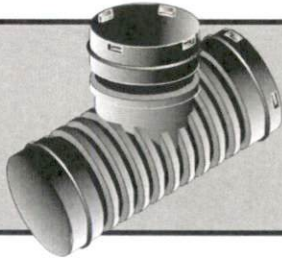

**Snap Combo End  
Cap/4"  
Reducer/Adapter**

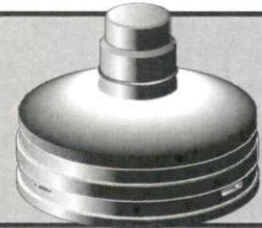

## CPP Gravelless LDP Trench Construction Details

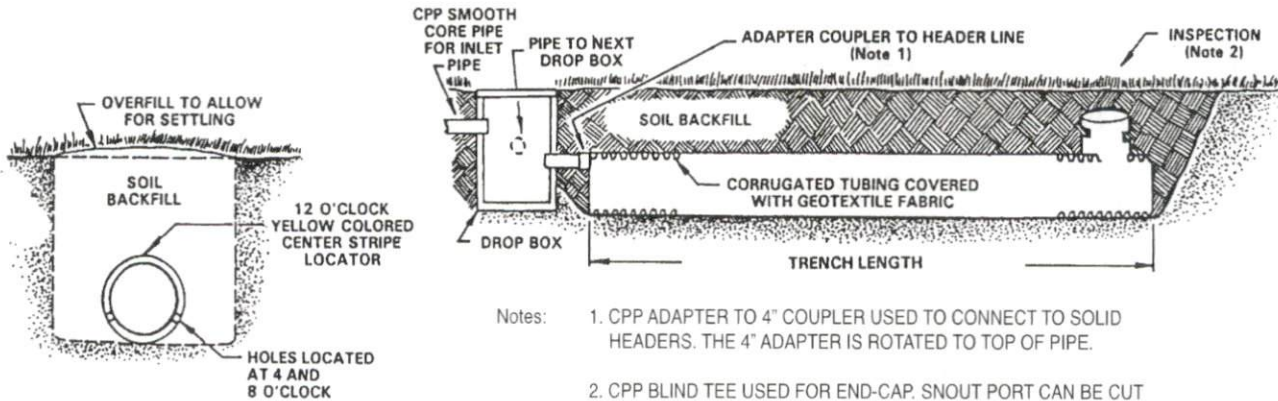

- Notes:
1. CPP ADAPTER TO 4" COUPLER USED TO CONNECT TO SOLID HEADERS. THE 4" ADAPTER IS ROTATED TO TOP OF PIPE.
  2. CPP BLIND TEE USED FOR END-CAP. SNOOT PORT CAN BE CUT OUT FOR INSTALLING A CLEAN OUT ADAPTER THAT ALLOWS FOR POST INSTALLATION INSPECTION.

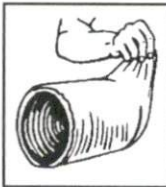

TYPE	SIZE	PART NO.	PACKAGE DESCRIPTION	PRICE
	8"	0830020B	CRUMPLER'S NO-ROCK™ SEPTIC - 20 ft. with filter wrap	
	10"	1030020B	CRUMPLER'S NO-ROCK™ SEPTIC - 20 ft. with filter wrap	

Large diameter (LDP) CPP GRAVELLESS septic tank trench systems use a filter wrap that allows for the installation of septic treatment pipes without gravel. The advantage in using CPP NO-ROCK is evident in areas where there is a shortage of inexpensive quality rock or where the shape and topography of a lot hinder the access of heavy construction equipment. Less equipment use means more trees can be saved,

less lot grading is needed, and thus fuel and labor are saved. Additionally, narrow trenches for 8" and 10" CPP pipes create a reduced OC (On-Center) Spacing between parallel septic trenches. An 8" CPP pipe can fit in a 10" wide trench and a 10" CPP pipe in a 12" wide trench. Thus Lot space is saved for other uses.



- Eliminates Rock
- Saves On Lot Grading
- Saves Trees On Lot
- Saves on Installation Labor
- Saves Fuel
- Increases Lot Value





# Crumpler's No-Rock™ Fabric Wrapped Large Diameter (LDP) Septic Pipe

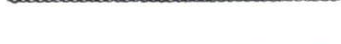

	TYPE	SIZE	PART NO.	PACKAGE DESCRIPTION	PRICE
		8"	0830020B	CRUMPLER'S NO-ROCK™ SEPTIC - 20 ft. with filter wrap	
		10"	1030020B	CRUMPLER'S NO-ROCK™ SEPTIC - 20 ft. with filter wrap	

Large diameter GRAVELLESS septic tank trench systems were developed as an alternative to 4" pipe systems in gravel-filled trenches for use in soils that most conventional 4" gravel would be allowed in. Organic Iron Ochre soils, however, are unsuitable for Filter Enclosed Gravelless Septic Pipes. The advantage in using the large diameter systems is evident in areas where there is a shortage of inexpensive quality rock, or where the shape and topography of a lot hinder the access of heavy construction equipment. The use of small trenchers for digging narrow trenches means more trees can be saved, less grading is needed, and thus fuel and labor are saved.

Crumpler's NO-ROCK™ septic systems include using either an 8" or a 10" corrugated HDPE pipe enclosed in a polypropylene filter wrap. ASTM-F-481 septic installation specification should be reviewed prior to installation. **Most states allow GRAVELLESS large diameter systems to be substituted for conventional systems in ANY SOIL TYPE deemed acceptable for a**

**conventional system.** One should check with local septic inspectors for locally approved soils.

Crumpler's NO-ROCK™ septic system may be substituted for any conventional 4" pipe gravel trench system utilizing distribution devices, serial distribution, hillside or stepdowns. However, it should not be substituted for bed systems. It should also be limited to domestic sewage, and not used where there will be large amounts of grease or oil such as in restaurants unless designed by an engineer.

The 8" size pipe will equal to 2-foot wide conventional trench; and the 10" size will equal a 2.5 foot wide trench. To determine the required linear footage of either pipe size, first determine the square footage by dividing the design sewage flow by the appropriate soil's long term application rate. Then divide this total square footage area figure by either 2 feet (for 8") or 2.5 feet (for 10") to establish the linear footage amount. Per chart below, on center (oc) spacing will be determined by actual trench width.

Example: A 3-bedroom house on a loam soil  
0.6 gpd/ft<sup>2</sup> = loam soil's long term application rate.

3BR x 120 gpd = 360 gpd  
360 gpd ÷ 0.6 gpd/ft<sup>2</sup> = 600 ft.

600 ft<sup>2</sup> ÷ 2ft = 300 linear ft of 8" or  
600 ft<sup>2</sup> ÷ 2.5 ft = 240 linear ft of 10"  
600 ft<sup>2</sup> ÷ 3 ft = 200 ft for conventional 4" gravel

SUGGESTED INSTALLATION OF STANDARDS

Nitrification trench bottom minimum width for 8".....	10"
Nitrification trench bottom minimum width for 10".....	12"
Nitrification line center spacing on 8".....	5' oc
Nitrification line center spacing on 10".....	6' oc
Nitrification trench bottom minimum depth.....	18"
Nitrification trench bottom maximum depth (24" preferred).....	36"
Nitrification trench bottom slope.....	level to 1" per 100 ft
Nitrification line minimum cover.....	6"
Nitrification line maximum cover (12" preferred).....	24"

To eliminate voids and clods under pipes 15" - 18" trenches is recommended unless sand backfill is used.

The corrugated pipe used shall comply with ASTM-F-667. Also the installer should be careful to note that the filter wrap is light

sensitive, and should not be exposed to sunlight for extended periods of time. The installer should also take care during installation to avoid tearing of the filter material. The protective plastic wrap that protects the filter should be disposed of off site.

WEB SITE: [www.cpp-pipe.com](http://www.cpp-pipe.com) / E-Mail: [cppsales@cpp-pipe.com](mailto:cppsales@cpp-pipe.com)

**(800) 334-5071**  
TOLL FREE USA/CANADA

OUR PIPE IS LABORATORY TESTED

**(910) 525-5801**  
24 HOUR FAX SERVICE



# Slope Correction Table



NOTE: Add the inches from Slope Table to the MSD<sup>1</sup> to determine the RSD<sup>2</sup>

PERCENT SLOPE	10" Trench	12" Trench	18" Trench	24" Trench	36" Trench
6	0.6	0.7	1.1	1.4	2.2
12	1.2	1.4	2.2	2.9	4.3
18	1.8	2.2	3.2	4.3	6.5
24	2.4	2.9	4.3	5.8	8.6
30	3	3.6	5.4	7.2	10.8
36	3.6	4.3	6.5	8.6	13.0
42	4.2	5.0	7.6	10.1	15.1
48	4.8	5.8	8.6	11.5	17.3
54	5.4	6.5	9.7	13.0	19.4
60	6	7.2	10.8	14.4	21.6

NOTE: For sloping sites a calculation of the additional required soil depth is necessary using the table above or the following formula:  $RSD = MSD + (TW \times .S)$

Where; RSD = Required Soil Depth (inches),

MSD - Min. Soil Depth (Min. Soil Cover + Ht. of Sys. + Min. Separation) (in)

TW = Trench Width (inches), &

.S = Percent Slope (.00)

**Example:** Assume site for septic system dispersal field has a slope of 28% and the trench bottom is required to be 12 inches above a site limitation, such as, weathered rock or perched water table. Also, assume that the proposed site has a usable or acceptable soil depth of 38 inches. Further, a minimum soil cover of 6 inches is required over the dispersal system.

**Trial 1:** Conventional trench (36 inches wide, 12 inches gravel, 6 inches over) would require a usable soil depth of 40 inches. [40 inches RSD - 30 inches MSD + (36 inches TW x .28 S)] Thus, a conventional or 36 inch wide trench is unsuitable at this site.

**Trial 2:** Crumpler NO ROCK™ 8 inch ID (10 in. OD) installed in a 12 inch wide trench would require a usable soil depth of 31.4 inches. [31.4 RSD = 28 inches MSD + (12 inches TW x .28 S)] Therefore, site is acceptable for Crumpler 8 in. NO ROCK™.

**Trial 3:** Crumpler NO ROCK™ 10 inch ID (12 in. OD) installed in an 18 inch wide trench would require a usable soil depth of 35 inches. [35 inches RSD = 30 inches MSD + (18 inches TW x .28 S)] Therefore, site is acceptable for Crumpler 10 inch NO ROCK™.

<sup>1</sup> MSD is the minimum soil depth at 0% slope and is the sum of the min. separation distance between trench bottom and limiting horizon (typ. 12 in), plus the system height, plus the min. soil cover (typ. 6 in.).

<sup>2</sup> RSD is the required soil depth to install a trench on a sloping site with the added inches to meet the minimum separation distance on the uphill side of the trench.





# Septic Effluent Disposal Trenches on Sloping Sites (Cross Section View)

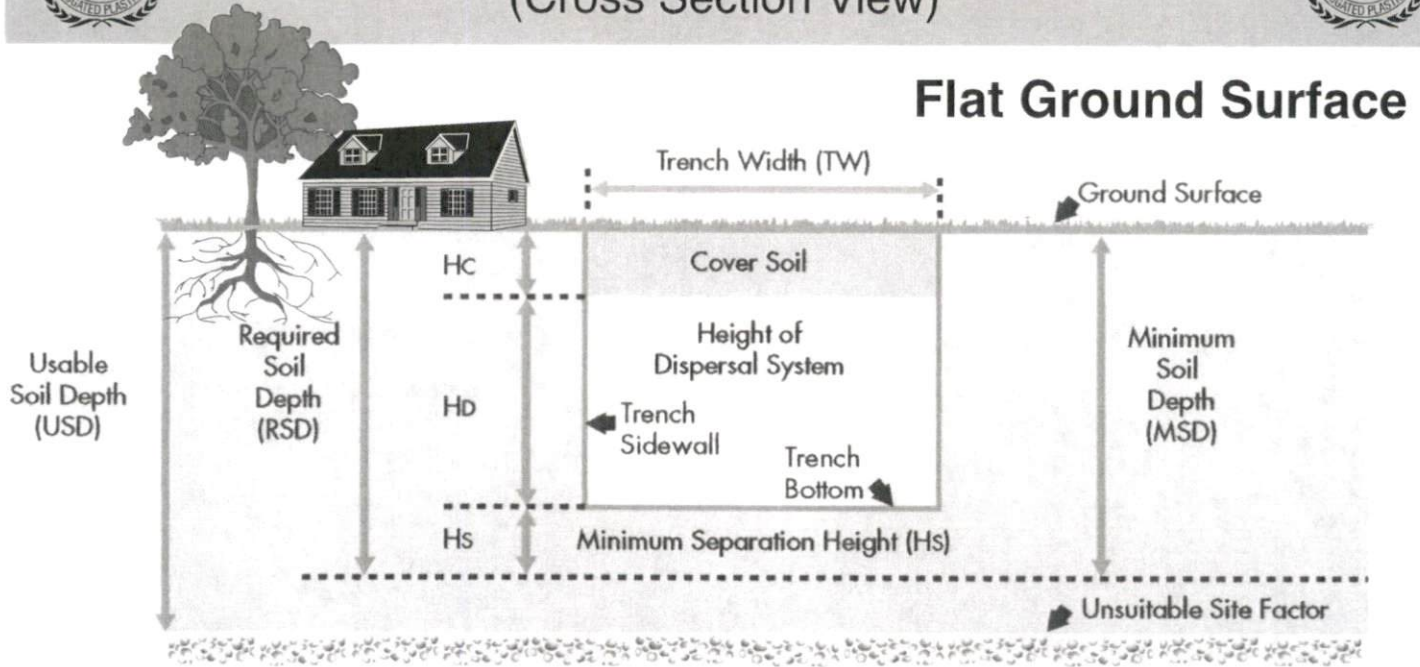

$MSD = H_c + H_d + H_s$   
 $MSD = RSD$  on Flat Sites

Not To Scale

FIGURE 1

## Sloping ground Surface

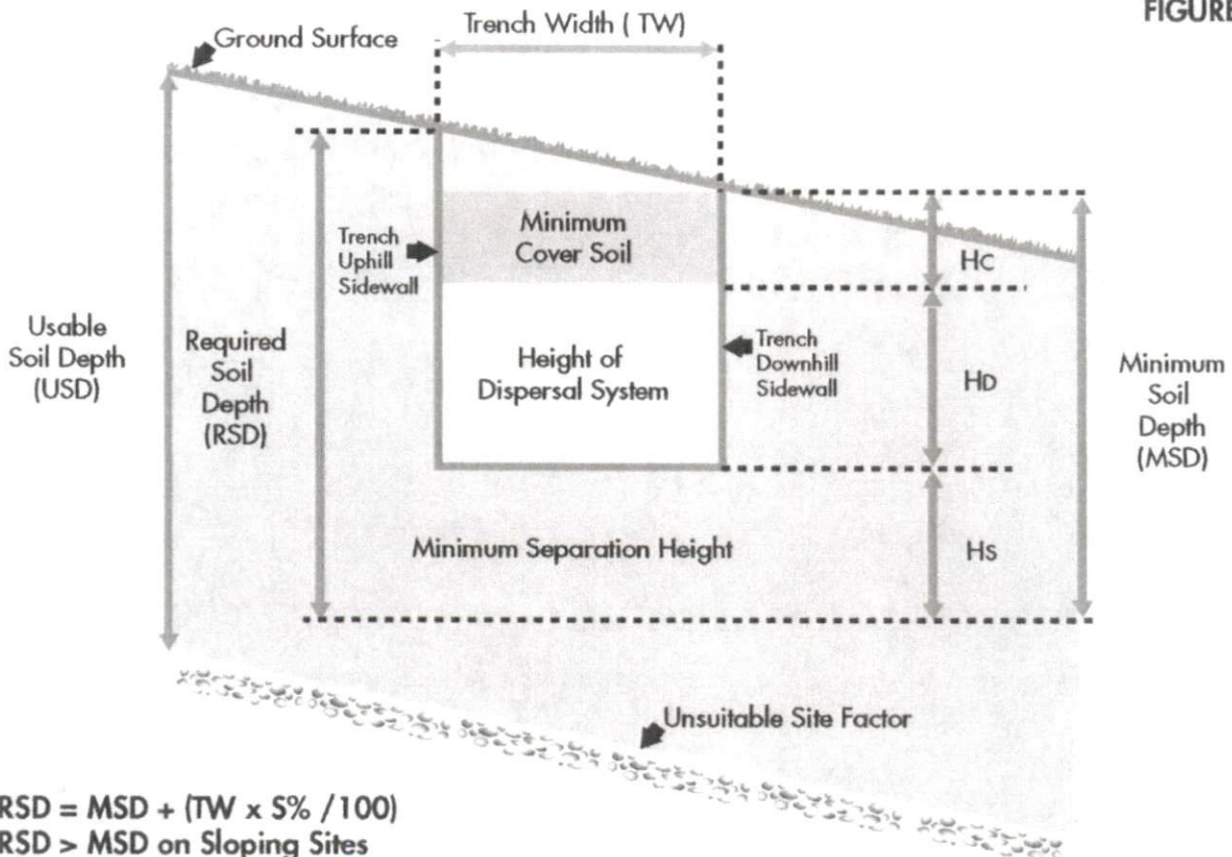

FIGURE 2

$RSD = MSD + (TW \times 5\% / 100)$   
 $RSD > MSD$  on Sloping Sites  
 $USD \geq RSD$

Not To Scale



# Septic Effluent Disposal Trenches on Sloping Sites (Cross Section View)



FIGURE 3

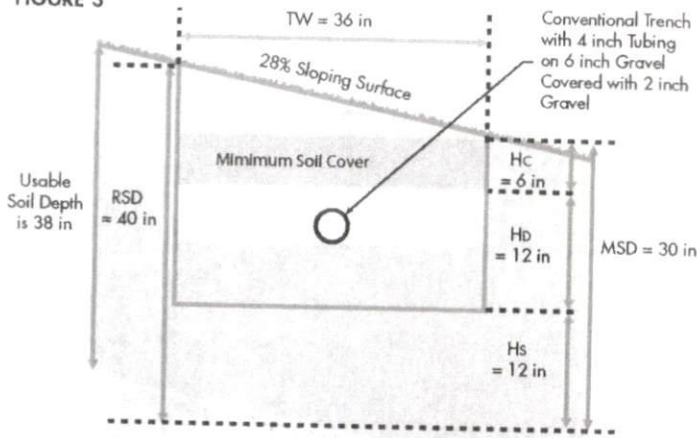

Not To Scale

Unsuitable Site Factor

## Septic Effluent Disposal Trenches on Sloping Sites (Cross Section) Trial No. 1

Site has 28% slope and soil is 38 inches deep

**Trial No. 1:** Use 36 inch wide conventional trench system

$$\text{MSD} = 6 \text{ in} + 12 \text{ in} + 12 \text{ in} = 30 \text{ inches}$$

$$\text{RSD} = 30 \text{ in} (36 \text{ in} \times 28\%/100) = 40 \text{ inches}$$

$$\text{RSD (40 in)} > \text{USD (38 in)}$$

Proposed System **Unsuitable** for Slope

## Septic Effluent Disposal Trenches on Sloping Sites (Cross Section) Trial No. 2

Site has 28% slope and soil is 38 inches deep

**Trial No. 2:** Use CPP 8 inch NO-ROCK™ with 12 inch wide trench.

$$\text{MSD} = 6 \text{ in} + 10 \text{ in} + 12 \text{ in} = 28 \text{ inches}$$

$$\text{RSD} = 30 \text{ in} (12 \text{ in} \times 28\%/100) = 31.4 \text{ inches}$$

$$\text{USD (38 in)} > \text{RSD (31.4 in)}$$

Proposed **CPP 8 inch NO-ROCK™** **Suitable** for Slope

FIGURE 4

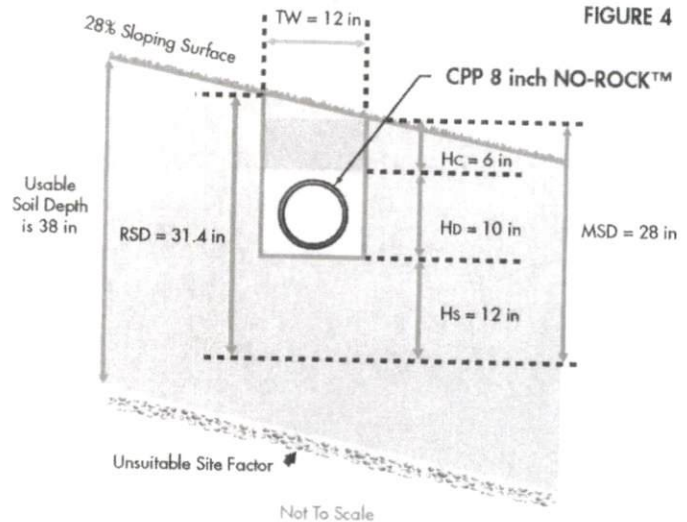

Not To Scale

## Septic Effluent Disposal Trenches on Sloping Sites (Cross Section) Trial No. 3

Site has 28% slope and soil is 38 inches deep

**Trial No. 3:** Use CPP 10 inch NO-ROCK™ with 18 inch wide trench.

$$\text{MSD} = 6 \text{ in} + 12 \text{ in} + 12 \text{ in} = 30 \text{ inches}$$

$$\text{RSD} = 30 \text{ in} (18 \text{ in} \times 28\%/100) = 35 \text{ inches}$$

$$\text{USD (38 in)} > \text{RSD (35 in)}$$

Proposed **CPP 10 inch NO-ROCK™** **Suitable** for Slope

FIGURE 5

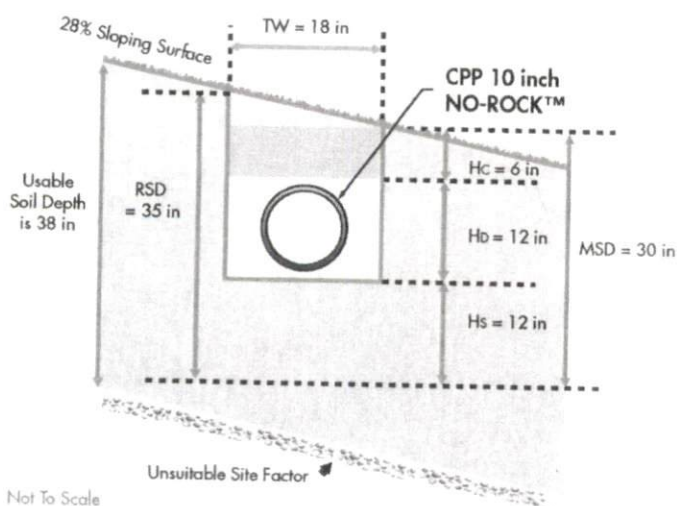

Not To Scale

Unsuitable Site Factor



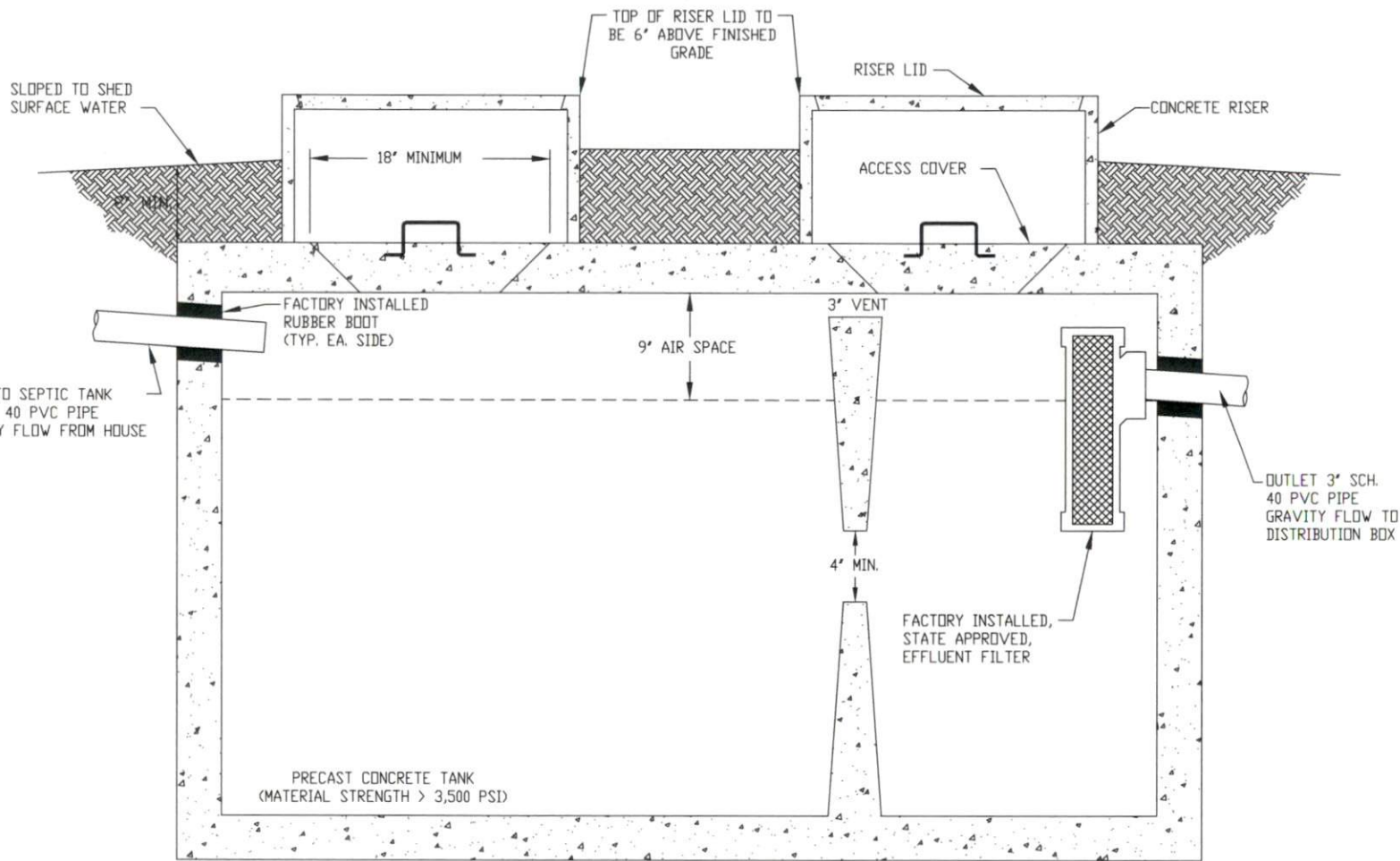

1,000 GALLON SEPTIC TANK

**SEPTIC TANK DETAIL**

N.T.S.

<b>SHEET NUMBER</b>		<b>4 of 5</b>	
DATE		March 31, 2022	
REVISION NO.	Original Submittal	Revision 1	Revision 2
REVISION NO.	Revision 3	Revision 4	Master Set
PREPARED FOR:	Edley & Thomas 10100 E. 111th Holly Springs, NC 27540	DATE:	March 31, 2022
DESIGNER CONTACT:	ADAM AYCOCK, EIT	DRAWN BY:	ADAM AYCOCK, EIT
<b>MITCHELL ENVIRONMENTAL, PA</b> <b>C-2911</b> <b>1501 LAKESTONE VILLAGE LANE</b> <b>SUITE 205</b> <b>FUQUAY VARINA, NC 27526</b>			
Prince Place Lot 14 Septic Tank Detail			

Trench Width = 12 Inches  
 Trench Depth = See Harnett County permit

**CPP Gravelless LDP Trench Construction Details**

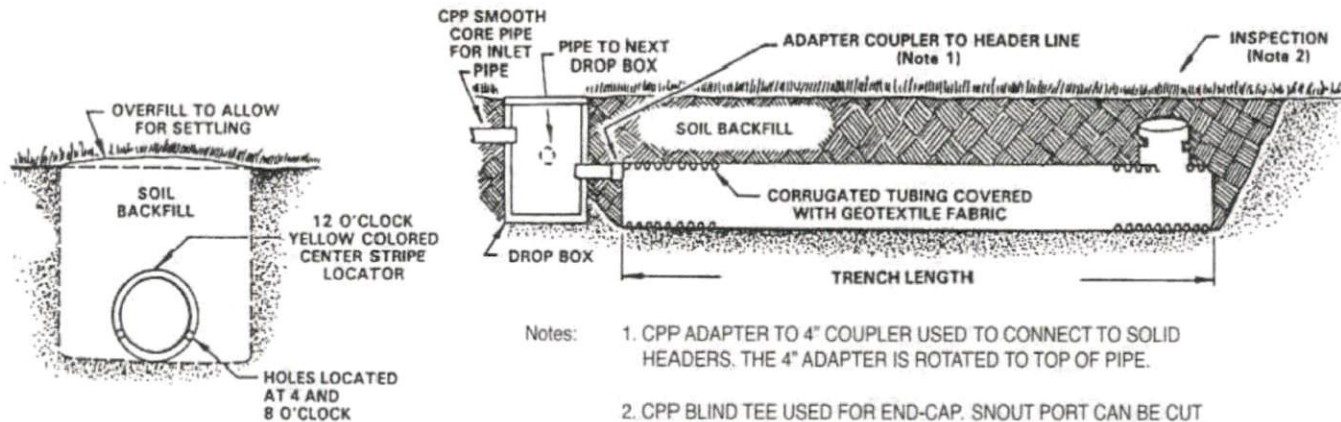

- Notes:
1. CPP ADAPTER TO 4" COUPLER USED TO CONNECT TO SOLID HEADERS. THE 4" ADAPTER IS ROTATED TO TOP OF PIPE.
  2. CPP BLIND TEE USED FOR END-CAP. SNOOT PORT CAN BE CUT OUT FOR INSTALLING A CLEAN OUT ADAPTER THAT ALLOWS FOR POST INSTALLATION INSPECTION.

<b>MITCHELL ENVIRONMENTAL, PA</b> C-2917 1501 LAKESTONE VILLAGE LANE SUITE 205 FURQUAY VARINA, NC 27526	PREPARED FOR : Type A Home Holly Springs, NC 27540	REVISION NO. Original Submitted	DATE March 31, 2022	SHEET NUMBER 5 of 5
	DATE : March 31, 2022 DESIGNER CONTACT: Dumpster Plastic Pipe DRAWN BY: Dumpster Plastic Pipe	Revision 1 Revision 2 Revision 3 Master Set	Prince Place Lot 14 Large Diameter Pipe Detail	

