

LOT INFORMATION:

PIN: 0652-04-3553.000
 TOTAL LOT AREA = 0.572 AC = 24,956 SF
 HOUSE = 2,530 SF
 PORCH = 74 SF
 SIDEWALK = 49 SF
 DRIVEWAY = 890 SF
 PATIO = 100 SF
 SCREENED PATIO = 100 SF
 AC PAD = 9 SF
 PROPOSED IMPERVIOUS = 3,752 SF
 PERCENT IMPERVIOUS = 15.03 %
 MAXIMUM ALLOWED IMPERVIOUS = 4,000 SF

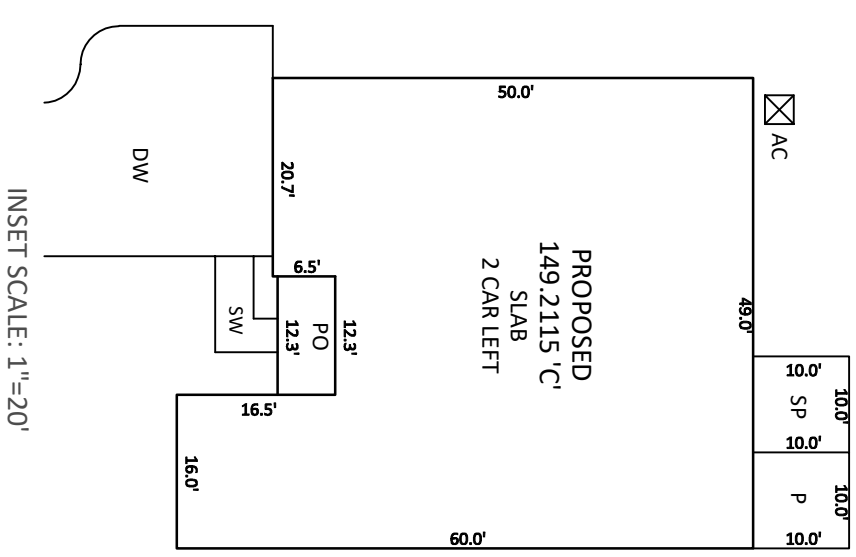

INSET SCALE: 1"=20'

- NOTES:**
1. THIS SURVEY WAS PREPARED BY BATEMAN CIVIL SURVEY CO., UNDER THE SUPERVISION OF STEVEN P. CARSON, PLS.
 2. THIS PLAN HAS BEEN PREPARED FOR LAYOUT AND PERMITTING PURPOSES ONLY. PROPERTY LINES SHOWN WERE TAKEN FROM EXISTING FIELD EVIDENCE, EXISTING DEEDS AND/OR PLATS OF PUBLIC RECORD, AND INFORMATION SUPPLIED TO THE SURVEYOR BY THE CLIENT.
 3. ALL DISTANCES ARE HORIZONTAL GROUND DISTANCES AND ALL BEARINGS ARE NORTH CAROLINA STATE PLANE COORDINATE SYSTEM UNLESS OTHERWISE SHOWN.
 4. THIS MAP IS NOT FOR RECORDATION AND SHOULD BE REVIEWED BY A LOCAL GOVERNMENT AGENCY FOR COMPLIANCE WITH ANY APPLICABLE LAND DEVELOPMENT REGULATIONS.
 5. THE BASIS OF NORTH AND ALL EASEMENTS, RIGHTS-OF-WAYS, BUFFERS, SETBACKS AND ADJOINERS, ETC., REFERENCED IN TITLE BLOCK.
 6. NO INVESTIGATION INTO THE EXISTENCE OF JURISDICTIONAL WETLANDS OR RIPARIAN BUFFERS PERFORMED BY THIS FIRM.
 7. SURVEYOR HAS MADE NO INVESTIGATION OR INDEPENDENT SEARCH FOR EASEMENTS OF RECORD, ENCUMBRANCES, RESTRICTIVE COVENANTS, OWNERSHIP TITLE EVIDENCE OR ANY OTHER FACTS THAT AN ACCURATE AND CURRENT TITLE SEARCH MAY DISCLOSE.
 8. THE PROPERTY LIES IN ZONE 'X' PER NATIONAL FLOOD INSURANCE PROGRAM F.I.R.M. MAP #37200642001, DATED OCTOBER 03 2006.
 9. ZONING IS: RA-40
 10. A 5' PUBLIC UTILITY EASEMENT LIES PARALLEL TO THE ROADWAY RIGHT OF WAY ALONG EACH SIDE, EXCEPT OPEN SPACE 4.
 11. PROPERTY OWNER: KB HOME RALEIGH- DURHAM INC.
4506 S. MIAMI BLVD. #100
DURHAM, NC. 27703

CURVE TABLE

CURVE	RADIUS	LENGTH	CHORD DIRECTION	CHORD
C37	50.00'	29.35'	S59°43'02"E	28.93'
C38	25.00'	15.22'	S60°20'10"E	14.98'
C39	25.00'	39.52'	N66°49'32"E	35.60'

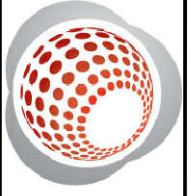
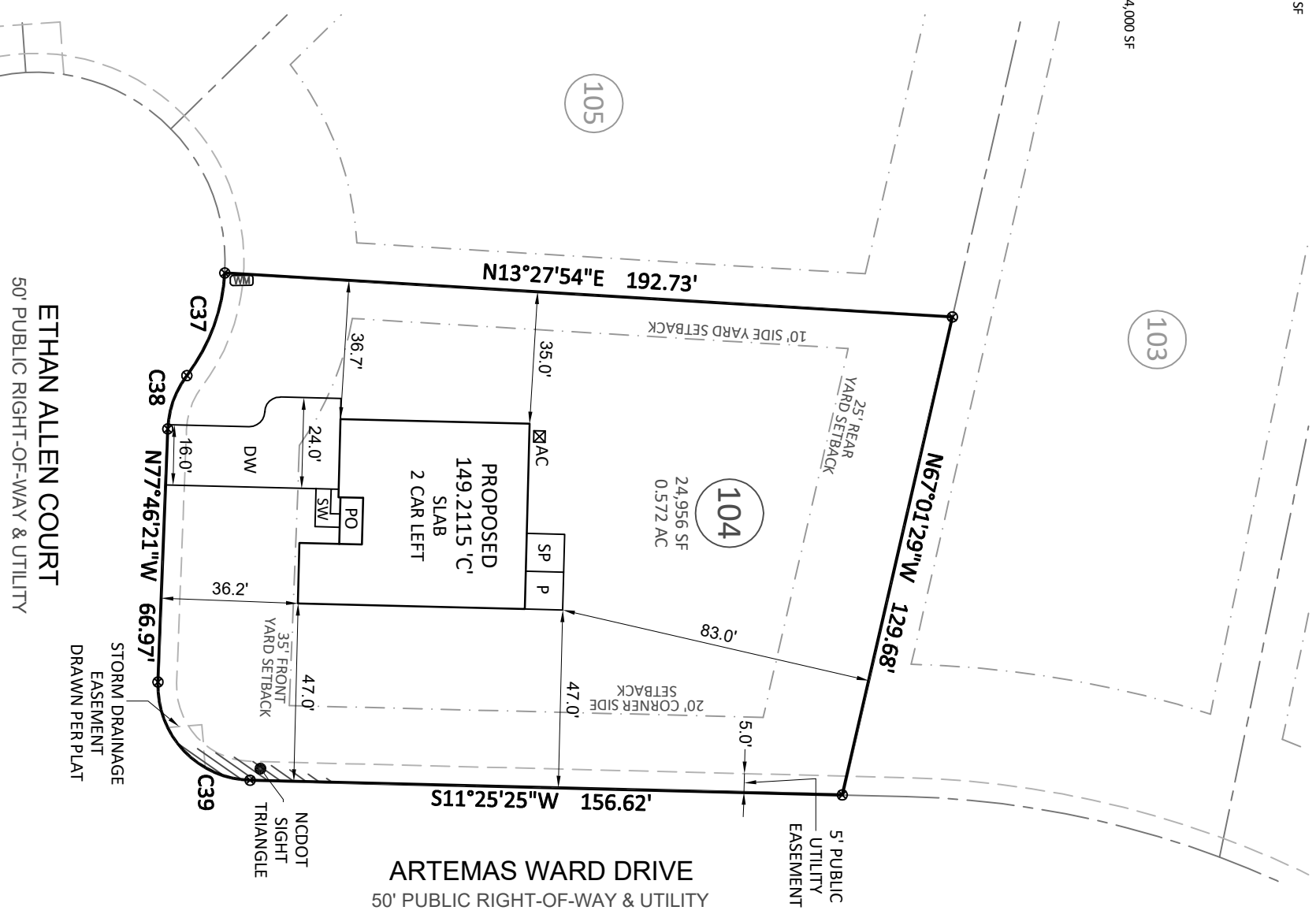

Bateman Civil Survey Company

Engineers • Surveyors • Planners
 2524 Reliance Avenue, Apex, NC 27539 Ph: 919.577.1080 Fax: 919.577.1081
 www.batemancivilsurvey.com info@batemancivilsurvey.com
 NCBELS Firm No. C-2378

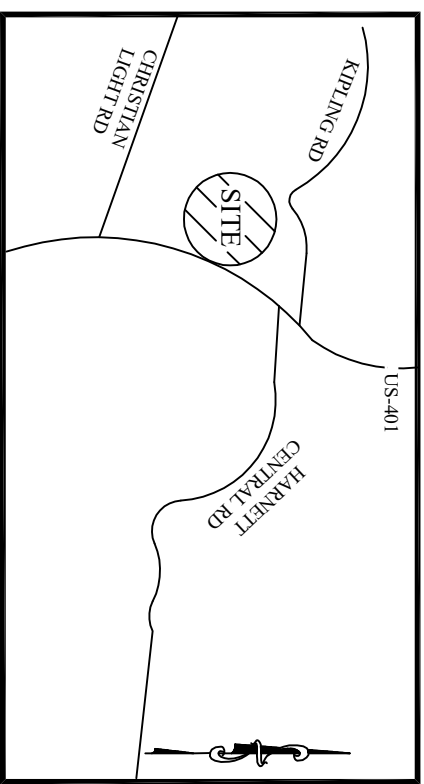

VICINITY MAP
(Not to Scale)

- LEGEND**
- PO = PORCH
 - P = PATIO
 - SP = SCREENED PORCH OR PATIO
 - CP = COVERED PORCH OR PATIO
 - WD = WOOD DECK
 - SW = SIDEWALK
 - DW = CONC DRIVEWAY
 - ⊗ = COMPUTED POINT
 - ⊙ = IRON PIPE FOUND
 - ⊚ = IRON PIPE SET (IPS)
 - ⊕ = WATER METER
 - ⊖ = CLEANOUT
 - AC = AIR CONDITIONER
 - ⊞ = ELECTRIC BOX
 - ⊠ = CABLE BOX
 - ⊡ = TELEPHONE PEDESTAL
 - ⊙ = LIGHT POLE
 - ⊚ = CURB INLET
 - ⊙ = YARD INLET
 - ⊙ = YARD INLET
 - ⊙ = FIRE HYDRANT
 - HP = HANDICAP PORTAJOHN WITH SCREENING
 - ⊙ = SEWER MANHOLE
 - ⊙ = FIRE HYDRANT
 - TR = TRASH RECEPTACLES
- BUILDING SETBACKS:**
 FRONT = 35'ft
 SIDE = 10'ft
 REAR = 25'ft
 CORNER SIDE = 20'ft
- This map is of an existing parcel of land and is only intended for the parties and purposes shown. This map not for recordation. No title report provided.

BUILDER TO VERIFY HOUSE LOCATION, DIMENSIONS AND REVIEW TOTAL IMPERVIOUS NOTED ON THIS PLOT PLAN

PRELIMINARY PLOT PLAN

FOR
KB HOMES

BIRCHWOOD GROVE - LOT 104
 ETHAN ALLEN COURT, FUQUAY-VARINA, NC
 HECTOR'S CREEK TOWNSHIP, HARNETT COUNTY

DATE: 4/4/22 DRAWN BY: AHB CHECKED BY: SPC
 REFERENCE: BK2022, PGS. 69-72 PROJECT# 220207 SCALE: 1"= 40'