

ITEM	QTY	PART NUMBER	BOM	DESCRIPTION
1	2	F_FOUND_49FT		FOUNDATION LAYOUT 49FT SHARING
2	2	F_PILLAR_ASSY		FOUNDATION PILLAR SINGLE
3	6	F_CHANNEL_F-1		CHANNEL 2"x4"
4	4	F_CHANNEL_F-2		CHANNEL 2"x4"
6	2	F_CHANNEL_F-4		CHANNEL 2"x4"
7	1	F_CHICKADEE_HOLE_LAYOUT		EXCAVATION DIMENSIONS
8	1	F_CHICKADEE_CONCRETE		CONCRETE VOLUMETRIC CAST

ZONE	REV	DESCRIPTION	ENG	DATE
	1	INITIAL RELEASE		2/20/2022
	2	UPDATED FOUNDATION WITH CONCRETE INFORMATION		3/11/2022

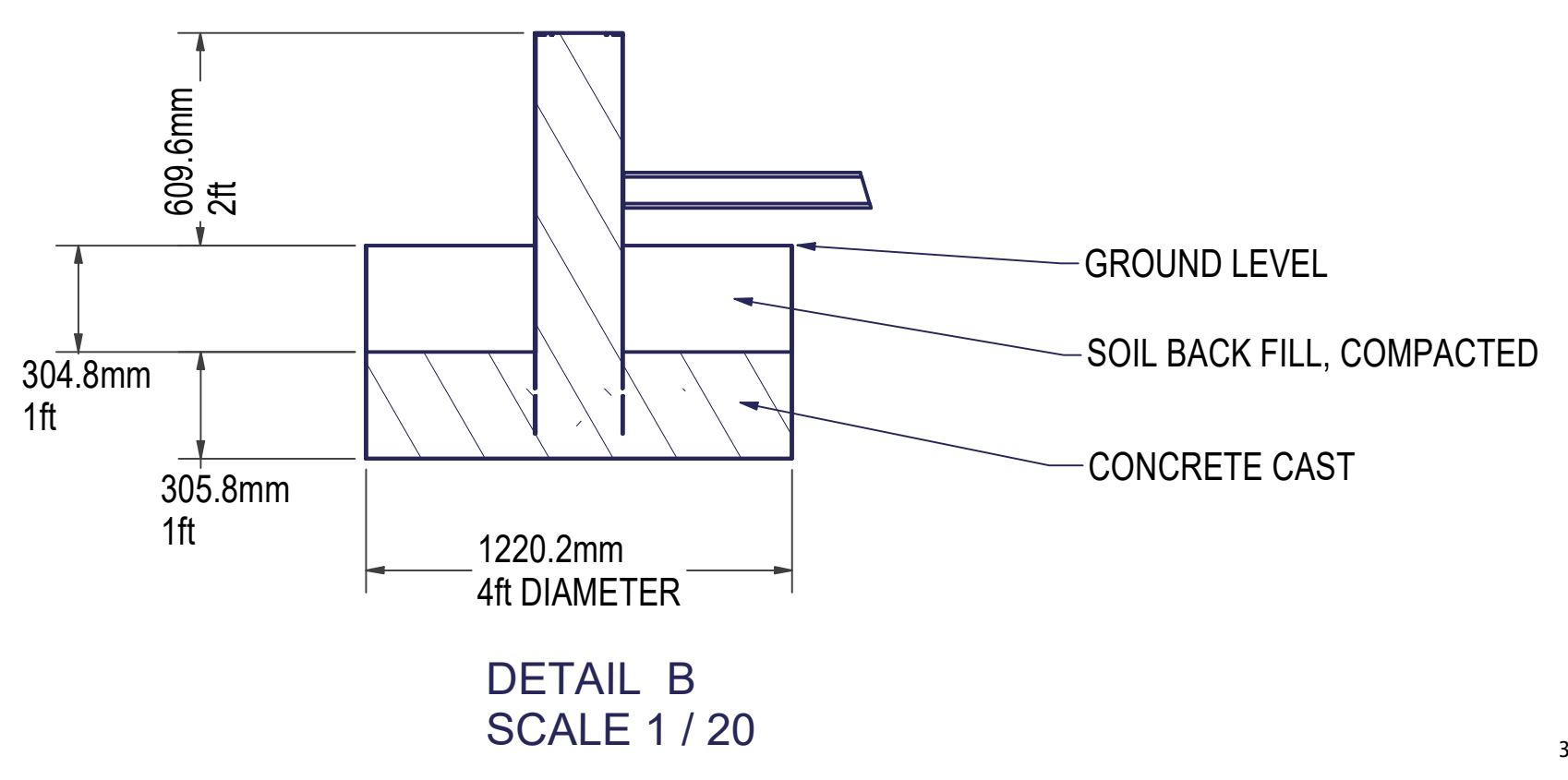
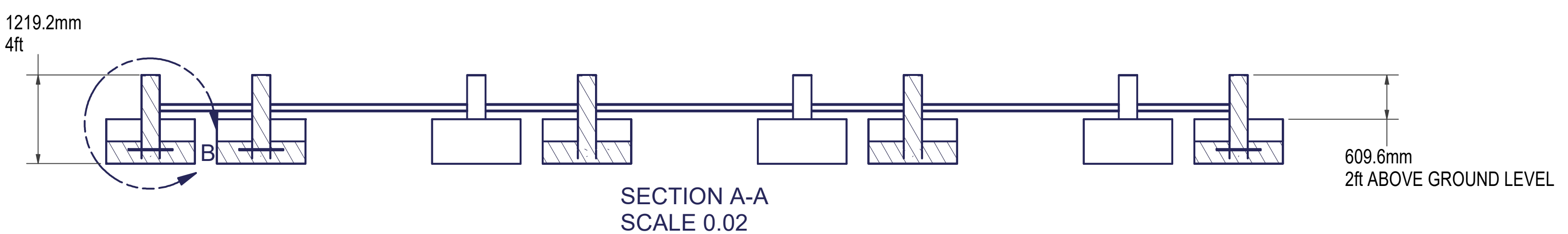
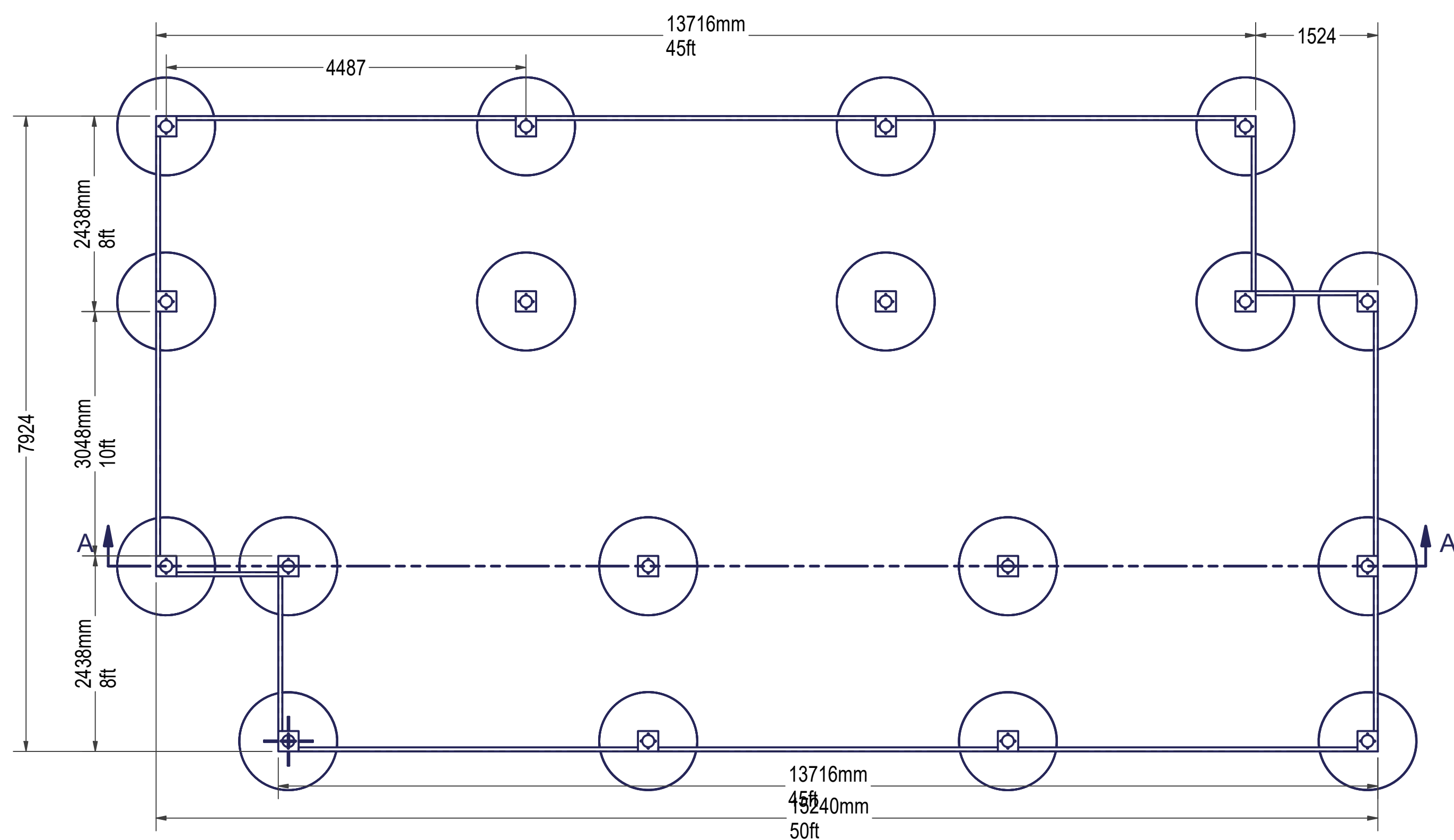
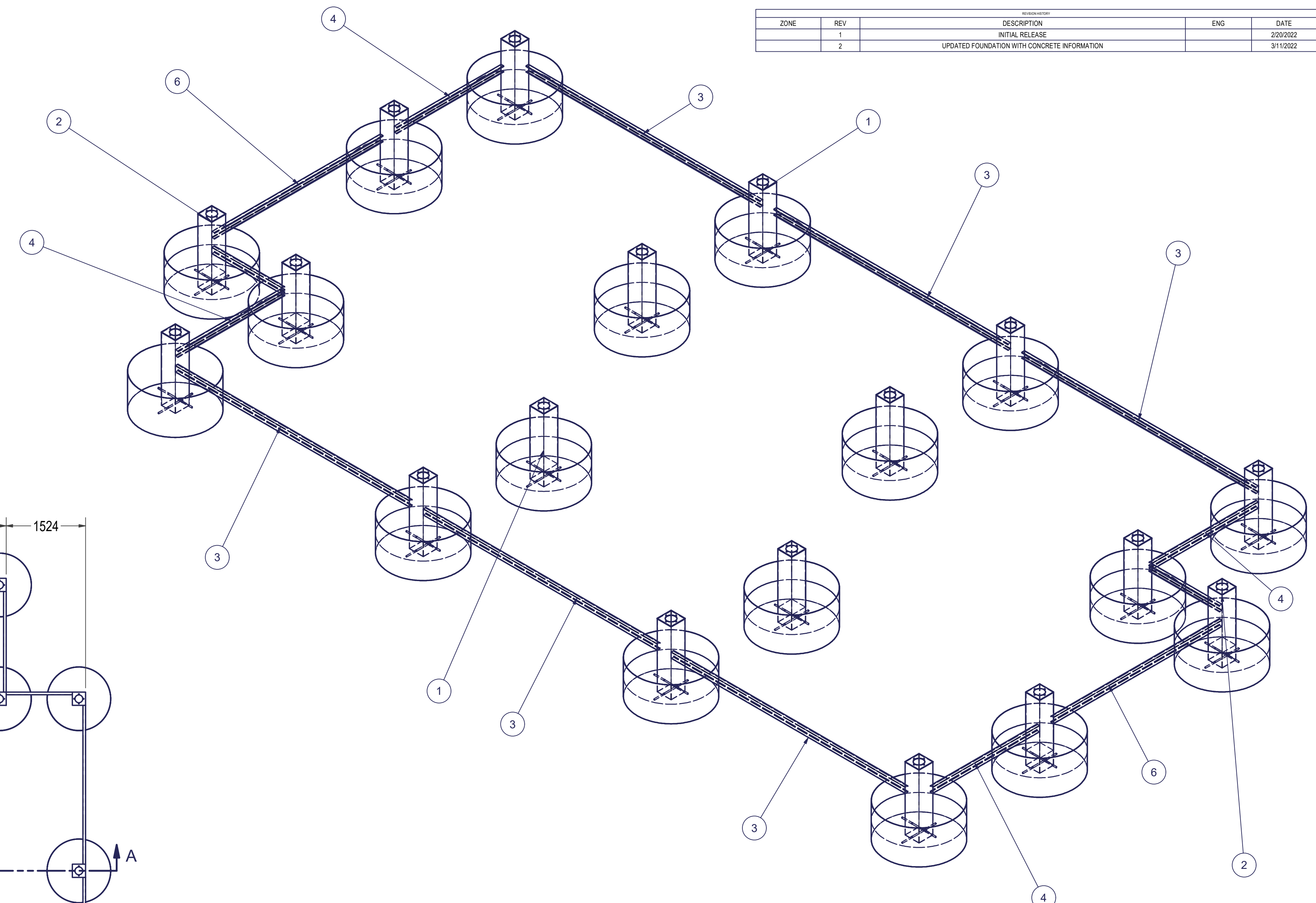

ORIGINAL SCALE UNLESS OTHERWISE STATED

COPYRIGHT
This drawing and any information or descriptive matters contained therein are the copyright property of
SELF SUSTAINABLE SOLUTIONS
Neither the whole nor any extract maybe disclosed, loaned, copied, or used for manufacturing or tending purposes without their written consent.

MATERIAL	
THICK	
MASS	N/A
VENDOR	INTEGRATOR
STOCK #	
DRAWN	Dirk Genis
DATE	2/20/2022

Robert L. Pennington PE
7629 Mallow Road
Wilmington, NC 28411
Email: robert@RLPPE.com
Phone: 910-520-0278

3/13/2022

SELF SUSTAINABLE SOLUTIONS

TITLE: FOUNDATION LAYOUT CHICKADEE

<p>FLAT PATTERN GEOMETRY IS GOVERNED BY DXF WITH THE EXPECTED TOLERANCE OF +/- 0.15mm ON ALL DXF CUTS</p>	<p>This print is shared on a confidential basis subject to return upon demand by SSS and nothing herein may be reproduced, used or disclosed in whole or in part without the prior written permission of Osprey.</p>	<p>UNLESS OTHERWISE SPECIFIED DIMENSIONS ARE IN MILLIMETERS</p>		<p>REMOVE ALL SHARP EDGES AND BURRS</p>																	
		<p>GENERAL TOLERANCES LINEAR DIMENSIONS</p>	<p>DIMENSION TOLERANCES ARE GOVERNED BY DIN ISO 2768-mK</p>																		
<table border="1"> <tr> <th>LINEAR</th> <th>0.5</th> <th>3</th> <th>10</th> <th>30</th> <th>100</th> <th>300</th> <th>1000</th> <th>3000</th> </tr> <tr> <td>±0.1</td> <td>±0.1</td> <td>±0.2</td> <td>±0.3</td> <td>±0.5</td> <td>±0.8</td> <td>±1.2</td> <td>±2.0</td> <td></td> </tr> </table>	LINEAR	0.5	3	10	30	100	300	1000	3000	±0.1	±0.1	±0.2	±0.3	±0.5	±0.8	±1.2	±2.0				<p>DRAWING NUMBER: F_CHICKADEE LAYOUT</p> <p>SHEET 1 OF 10 SIZE: B REVISION: 2</p>
LINEAR	0.5	3	10	30	100	300	1000	3000													
±0.1	±0.1	±0.2	±0.3	±0.5	±0.8	±1.2	±2.0														

BOM			
ITEM	QTY	PART NUMBER	DESCRIPTION
1	8	F_PILLAR ASSY	FOUNDATION PILLAR SINGLE

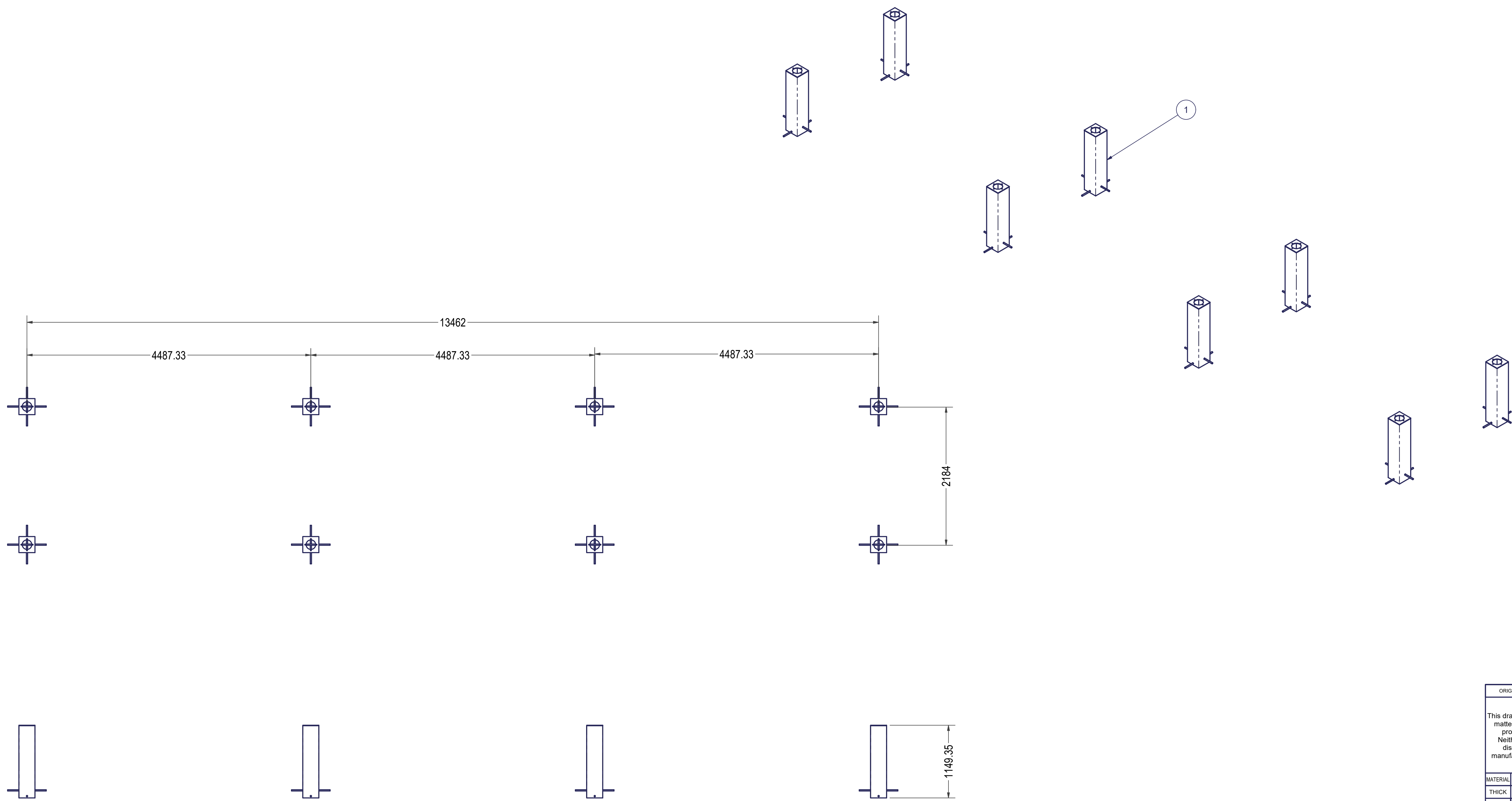

DocuSigned by:
 Robert L. Pennington
 00843963350F452
 3/13/2022

ROBERT L. PENNINGTON
 PROFESSIONAL ENGINEER
 SEAL 25045
 NORTH CAROLINA
 PROFESSIONAL ENGINEER
 ROBERT L. PENNINGTON

Robert L. Pennington PE
 7629 Mallow Road
 Wilmington, NC 28411
 Email: robert@RLPPE.com
 Phone: 910-520-0278

ORIGINAL SCALE UNLESS OTHERWISE STATED

COPYRIGHT

This drawing and any information or descriptive matters contained therein are the copyright property of OSPREA LOGISTICS Ltd. Neither the whole nor any extract may be disclosed, loaned, copied, or used for manufacturing or tendering purposes without their written consent.

MATERIAL	
THICK	
MASS	N/A
FINISH	NONE
ENGINEER	Dirk Genis
DRAWN	Dirk Genis
DATE	2/20/2022



FLAT PATTERN GEOMETRY IS GOVERNED BY DXF WITH THE EXPECTED TOLERANCE OF +/- 0.15mm ON ALL DXF CUTS		This print is shared on a confidential basis subject to return upon demand by Osprea and nothing hereon may be reproduced, used or disclosed in whole or in part without the prior written permission of Osprea.		UNLESS OTHERWISE SPECIFIED DIMENSIONS ARE IN MILLIMETERS GENERAL TOLERANCES LINEAR DIMENSIONS ALL OTHER FEATURE DIMENSION TOLERANCES ARE GOVERNED BY DIN ISO 2768-mK		REMOVE ALL SHARP EDGES AND BURRS		THIRD ANGLE PROJECTION		DRAWING NUMBER F_FOUND_40FT	
LINEAR	0.5	3	8	30	120	400	1000	2000	SHEET 2 OF 10 SIZE: B REVISION: 2		
	±0.1	±0.2	±0.3	±0.5	±0.8	±1.2	±2.0				

TITLE
 FOUNDATION LAYOUT 40FT, SHARING

ITEM	QTY	PART NUMBER	DESCRIPTION
1	1	PLATE BASE FOUNDATION	BASE PLATE
2	1	TUBE PILLAR	TUBE PILLAR
3	2	REBAR PILLAR SECTION	RUBAR #6 (Ø.75", 19MM)

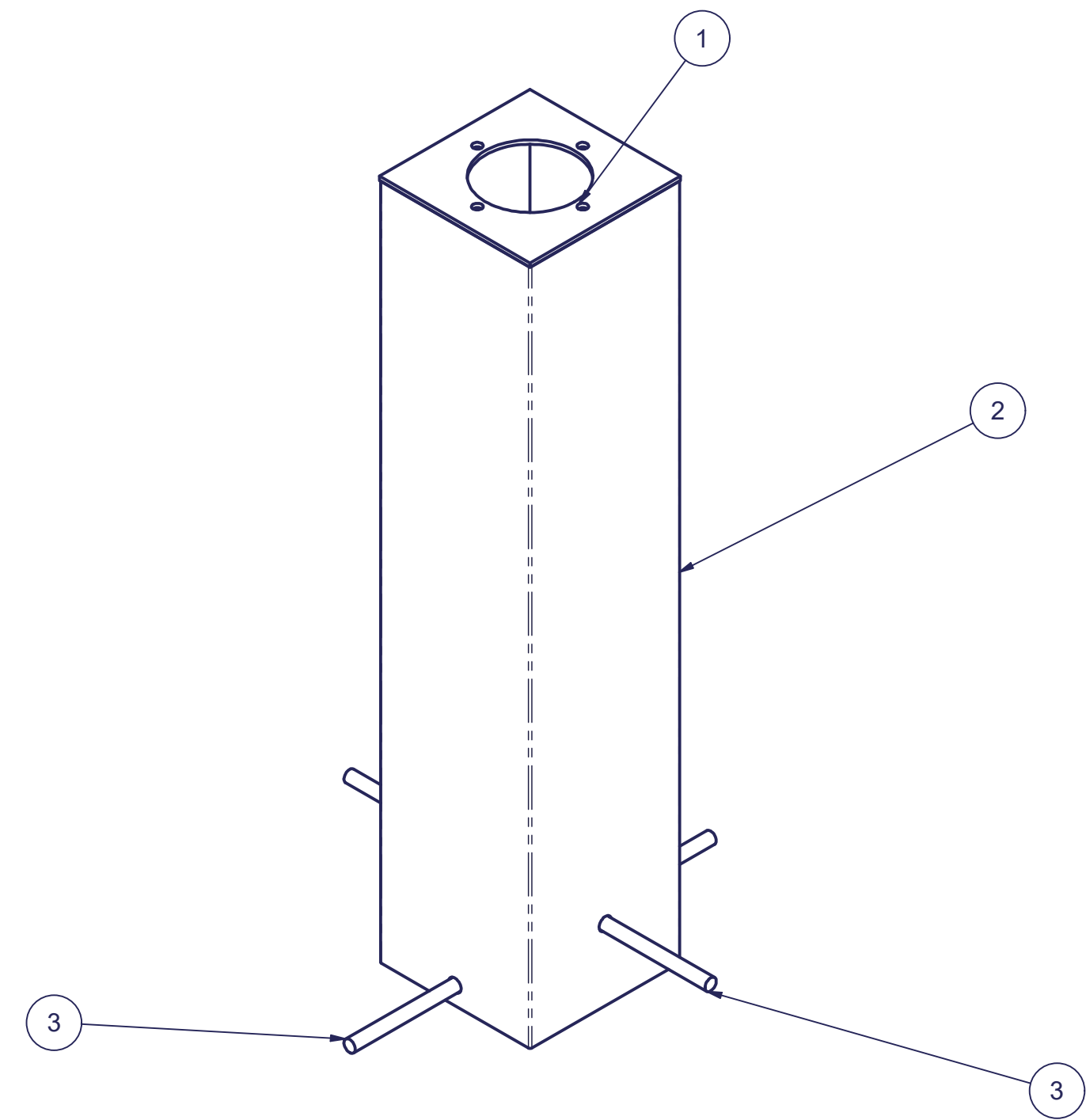
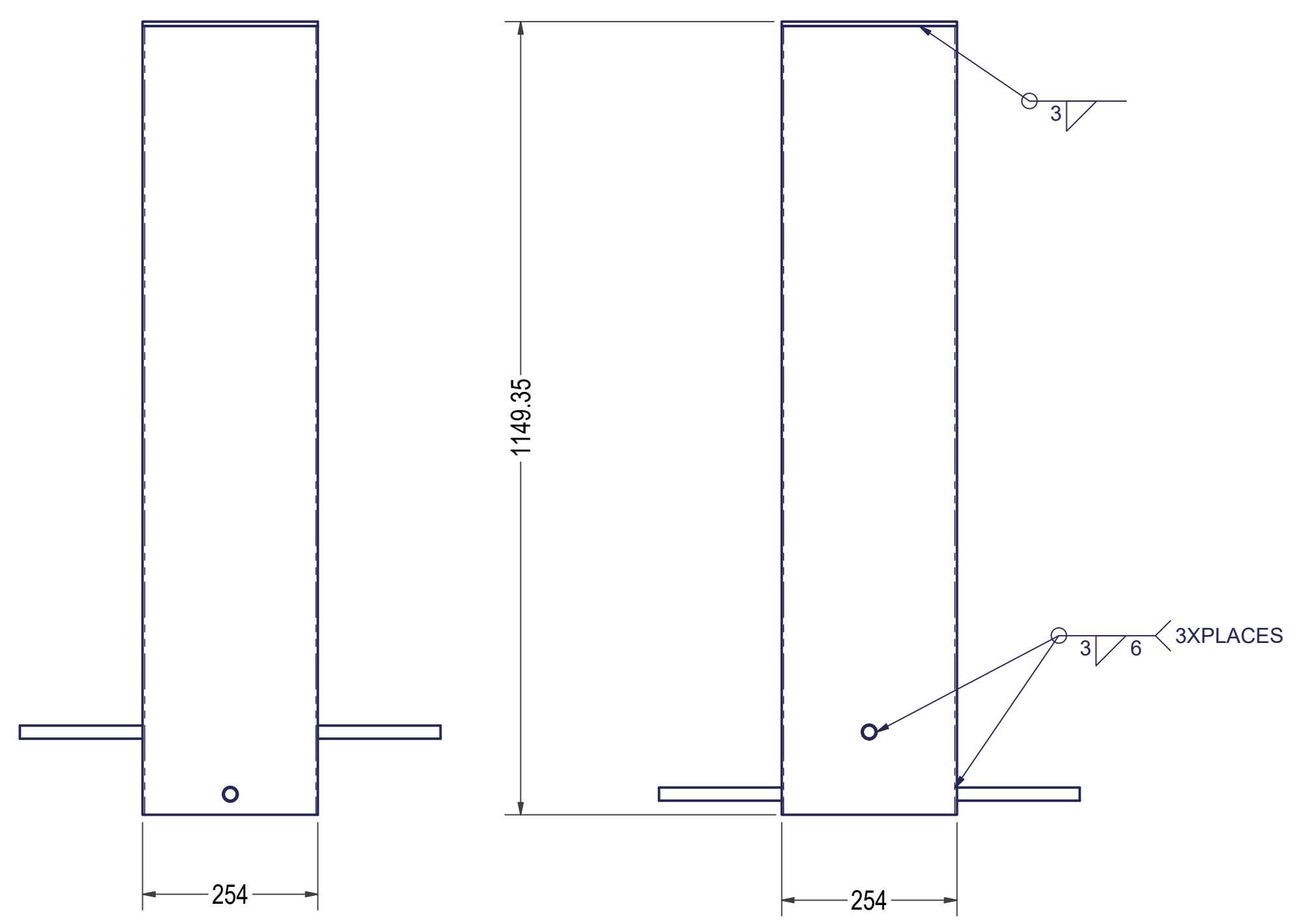
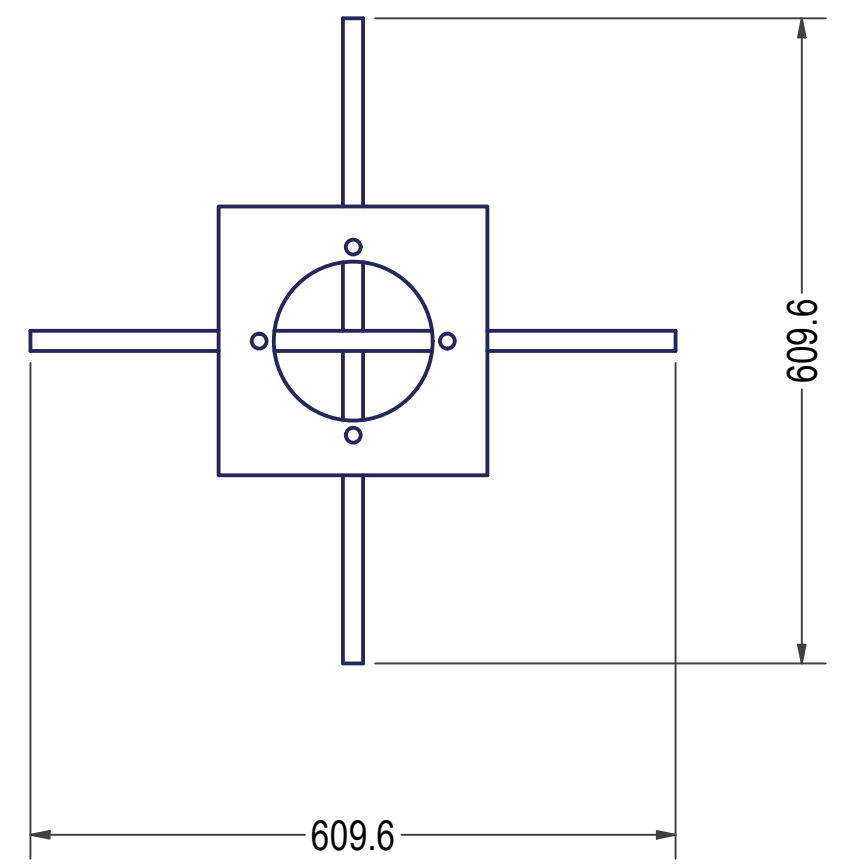

DocuSigned by:
 Robert L. Pennington
 3/13/2022

PROFESSIONAL SEAL
 ROBERT L. PENNINGTON, ENGINEER
 25045

Robert L. Pennington PE
 7629 Mallow Road
 Wilmington, NC 28411
 Email: robert@RLPPE.com
 Phone: 910-520-0278

ORIGINAL SCALE	UNLESS OTHERWISE STATED
COPYRIGHT	
This drawing and any information or descriptive matters contained therein are the copyright property of OSPREA LOGISTICS Ltd. Neither the whole nor any extract may be disclosed, loaned, copied, or used for manufacturing or tendering purposes without their written consent.	
MATERIAL	
THICK	
MASS	N/A
FINISH	NONE
ENGINEER	Dirk Genis
DRAWN	Dirk Genis
DATE	2/20/2022



FLAT PATTERN GEOMETRY IS GOVERNED BY DXF WITH THE EXPECTED TOLERANCE OF +/- 0.15mm ON ALL DXF CUTS This print is shared on a confidential basis subject to return upon demand by Osprea and nothing hereon may be reproduced, used or disclosed in whole or in part without the prior written permission of Osprea.	UNLESS OTHERWISE SPECIFIED DIMENSIONS ARE IN MILLIMETERS GENERAL TOLERANCES LINEAR DIMENSIONS		REMOVE ALL SHARP EDGES AND BURRS THIRD ANGLE PROJECTION
	DIMENSION TOLERANCES ARE GOVERNED BY DIN ISO 2768-mK	ALL OTHER FEATURE DIMENSION TOLERANCES ARE GOVERNED BY	

TITLE
 FOUNDATION PILLAR SINGLE

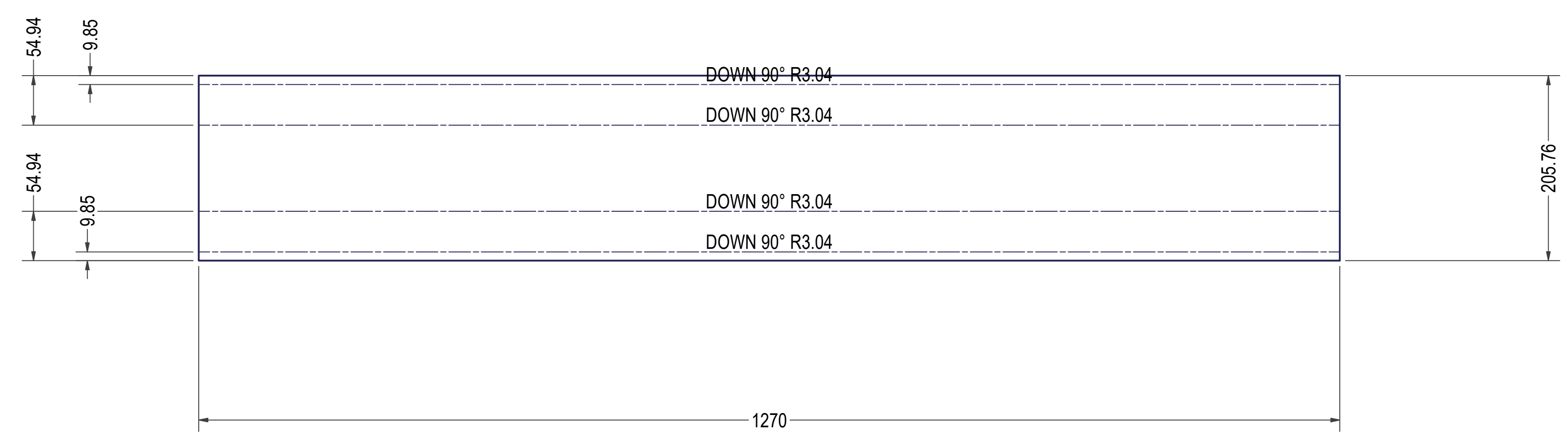
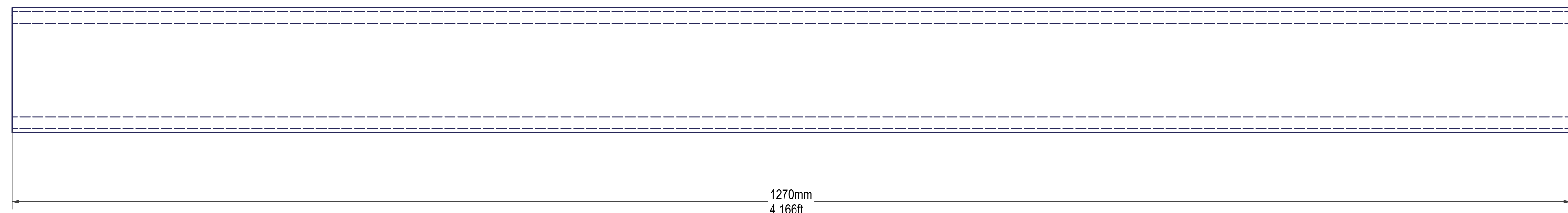
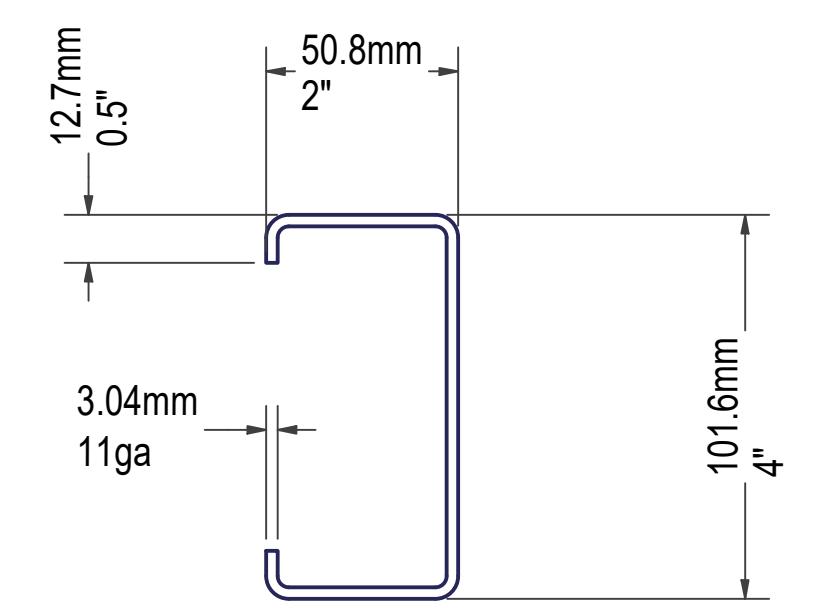
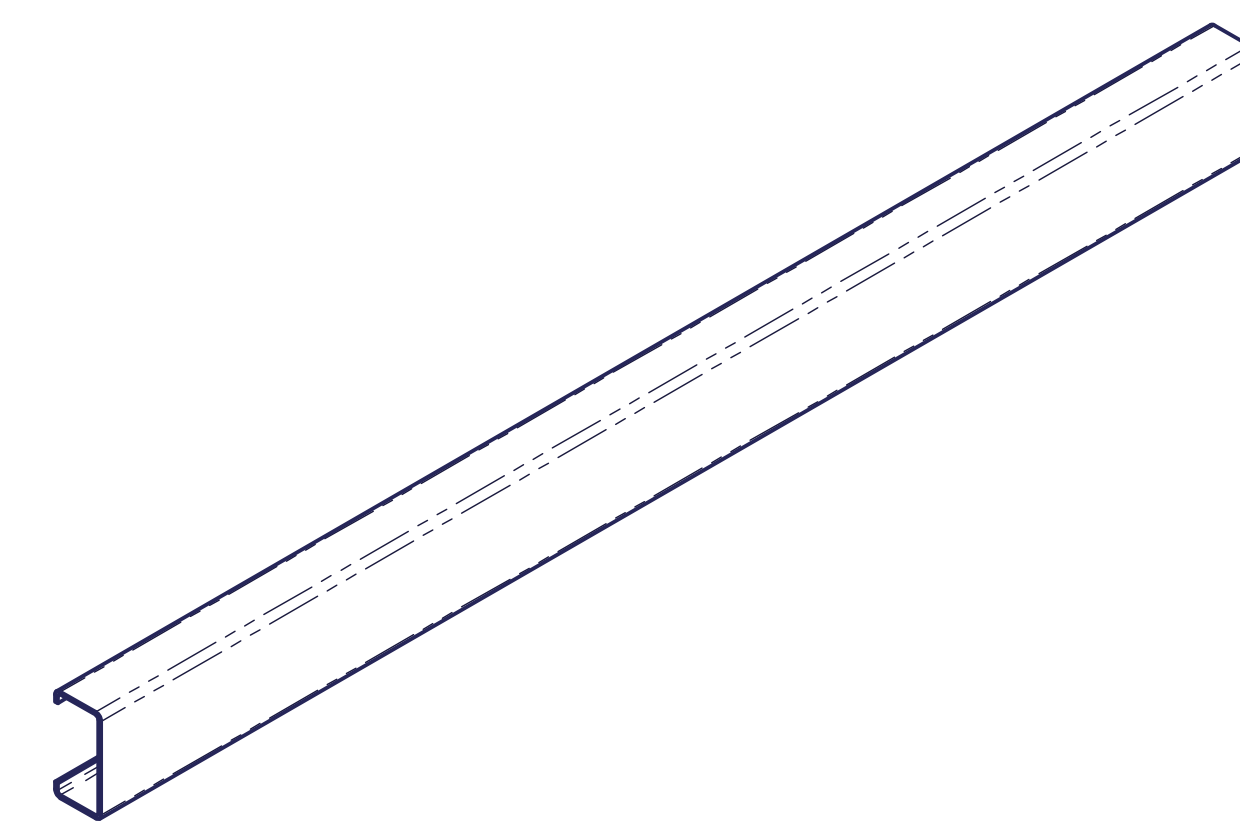

DXF FILE: CHANNEL F-3_1

DocuSigned by:
 Robert L. Pennington
 00643983350F452
 3/13/2022

Robert L. Pennington PE
 7629 Mallow Road
 Wilmington, NC 28411
 Email: robert@RLPPE.com
 Phone: 910-520-0278

ORIGINAL SCALE	UNLESS OTHERWISE STATED
COPYRIGHT	
This drawing and any information or descriptive matters contained therein are the copyright property of OSPREA LOGISTICS Ltd. Neither the whole nor any extract may be disclosed, loaned, copied, or used for manufacturing or tendering purposes without their written consent.	
MATERIAL	Steel ASTM A1011 CS Type B
THICK	3.038 mm
MASS	N/A
FINISH	NONE
ENGINEER	Dirk Genis
DRAWN	Dirk Genis
DATE	2/20/2022



TITLE
 CHANNEL 2"x4"

FLAT PATTERN GEOMETRY IS GOVERNED BY DXF WITH THE EXPECTED TOLERANCE OF +/- 0.15mm ON ALL DXF CUTS	This print is shared on a confidential basis subject to return upon demand by Osprea and nothing hereon may be reproduced, used or disclosed in whole or in part without the prior written permission of Osprea.	UNLESS OTHERWISE SPECIFIED DIMENSIONS ARE IN MILLIMETERS		REMOVE ALL SHARP EDGES AND BURRS	THIRD ANGLE PROJECTION	DRAWING NUMBER F_CHANNEL F-3
		GENERAL TOLERANCES LINEAR DIMENSIONS ALL OTHER FEATURE DIMENSION TOLERANCES ARE GOVERNED BY DIN ISO 2768-mK	SHEET 4 OF 10			

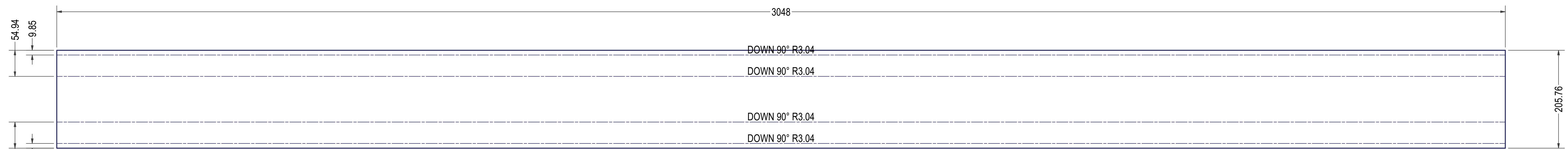
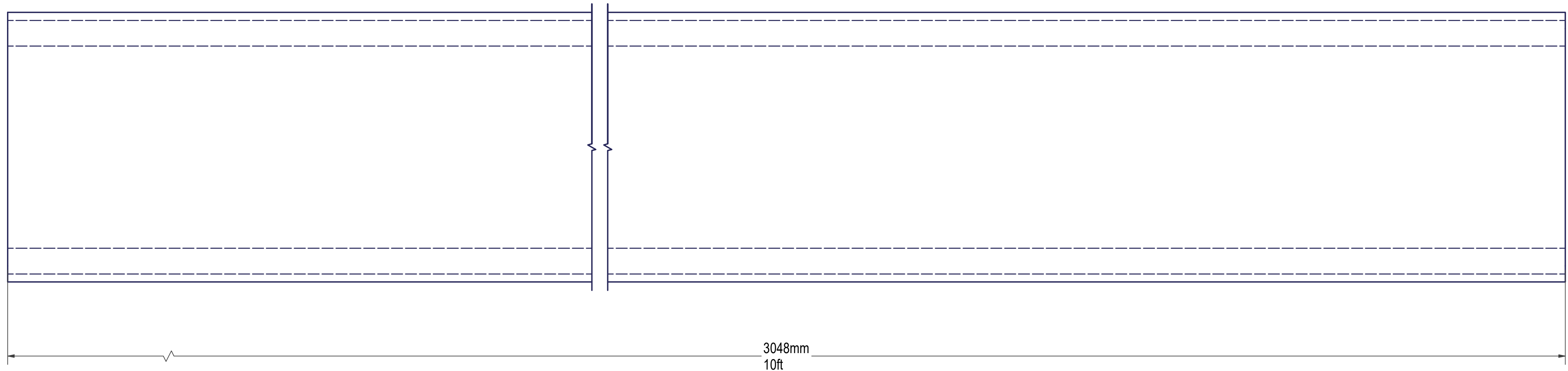
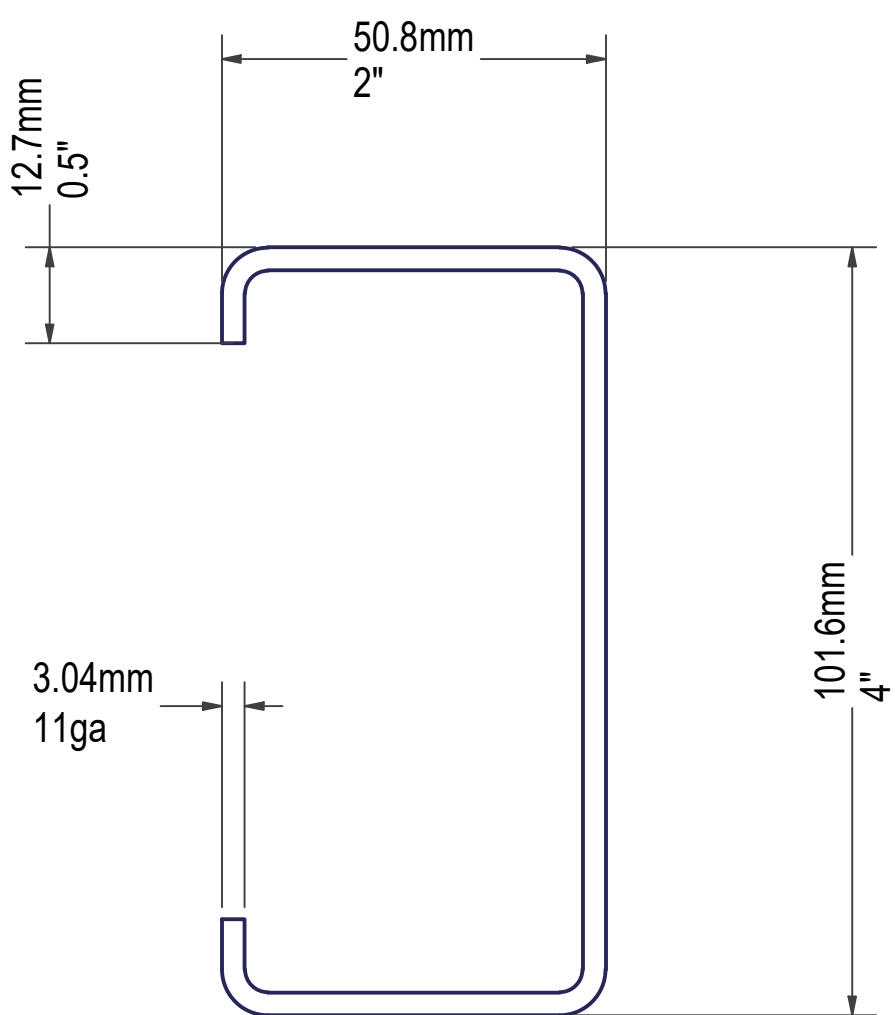

DXF FILE: CHANNEL F-4_1

DocuSigned by:
 Robert L. Pennington
 00643993350F452
 3/13/2022

Robert L. Pennington PE
 7629 Mallow Road
 Wilmington, NC 28411
 Email: robert@RLPPE.com
 Phone: 910-520-0278

ORIGINAL SCALE	UNLESS OTHERWISE STATED
COPYRIGHT	
This drawing and any information or descriptive matters contained therein are the copyright property of OSPREA LOGISTICS Ltd. Neither the whole nor any extract may be disclosed, loaned, copied, or used for manufacturing or tendering purposes without their written consent.	
MATERIAL	Steel ASTM A1011 CS Type B
THICK	3.038 mm
MASS	N/A
FINISH	NONE
ENGINEER	Dirk Genis
DRAWN	Dirk Genis
DATE	2/20/2022



TITLE
 CHANNEL 2"x4"

FLAT PATTERN GEOMETRY IS GOVERNED BY DXF WITH THE EXPECTED TOLERANCE OF +/- 0.15mm ON ALL DXF CUTS	This print is shared on a confidential basis subject to return upon demand by Osprea and nothing hereon may be reproduced, used or disclosed in whole or in part without the prior written permission of Osprea.	UNLESS OTHERWISE SPECIFIED DIMENSIONS ARE IN MILLIMETERS		REMOVE ALL SHARP EDGES AND BURRS
		GENERAL TOLERANCES LINEAR DIMENSIONS ALL OTHER FEATURE DIMENSION TOLERANCES ARE GOVERNED BY DIN ISO 2768-mK	THIRD ANGLE PROJECTION	
DRAWING NUMBER F_CHANNEL F-4		SHEET 5 OF 10		SIZE: B REVISION: 2

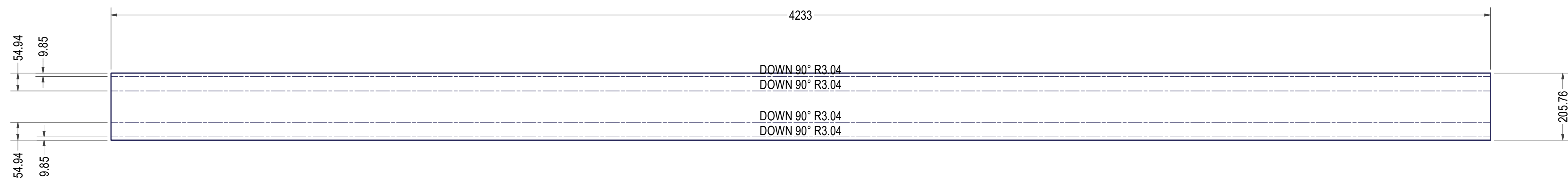
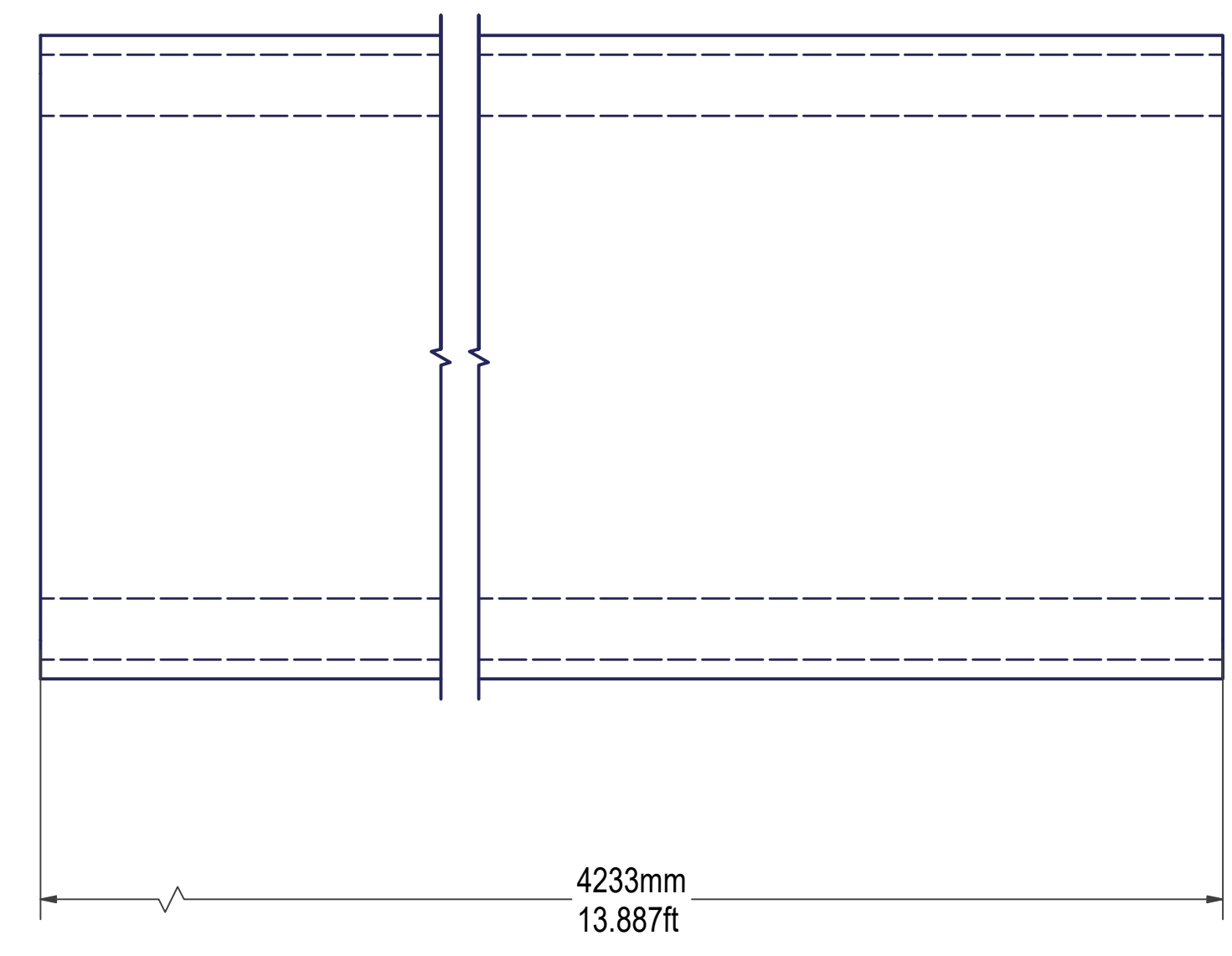
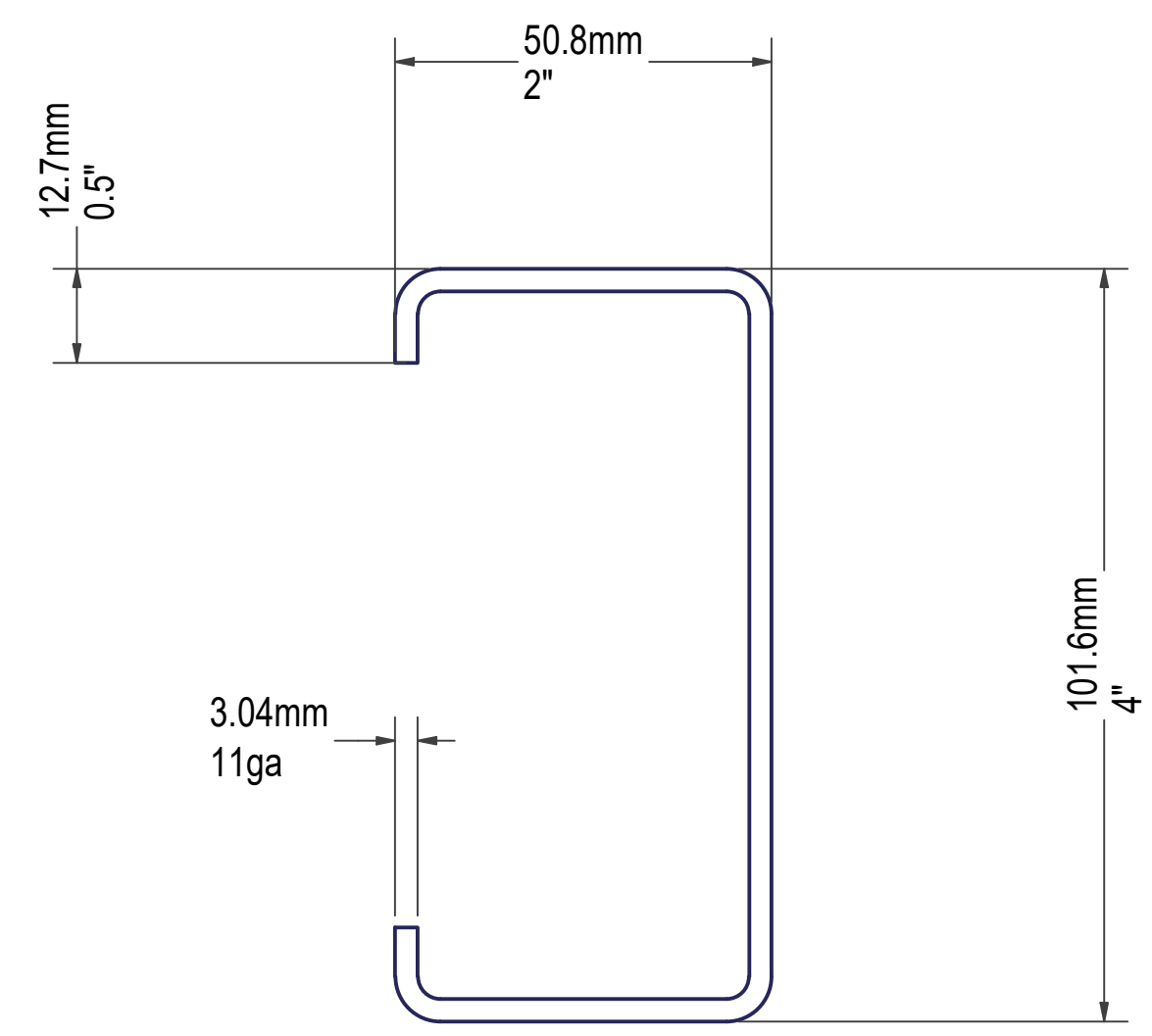

DXF FILE: CHANNEL F-1_1

DocuSigned by:
 Robert L. Pennington
 00643963350F452
 3/13/2022

Robert L. Pennington PE
 7629 Mallow Road
 Wilmington, NC 28411
 Email: robert@RLPPE.com
 Phone: 910-520-0278

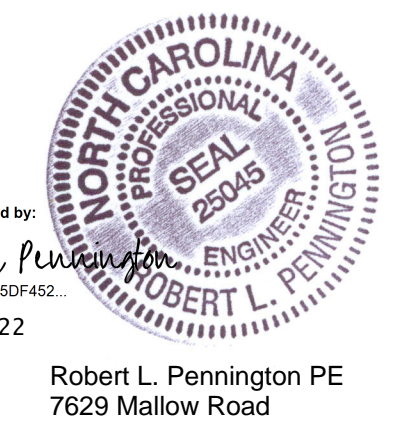

ORIGINAL SCALE	UNLESS OTHERWISE STATED
COPYRIGHT	
This drawing and any information or descriptive matters contained therein are the copyright property of OSPREA LOGISTICS Ltd. Neither the whole nor any extract may be disclosed, loaned, copied, or used for manufacturing or tendering purposes without their written consent.	
MATERIAL	Steel ASTM A1011 CS Type B
THICK	3.038 mm
MASS	N/A
FINISH	NONE
ENGINEER	Dirk Genis
DRAWN	Dirk Genis
DATE	2/20/2022



TITLE
CHANNEL 2"x4"

FLAT PATTERN GEOMETRY IS GOVERNED BY DXF WITH THE EXPECTED TOLERANCE OF +/- 0.15mm ON ALL DXF CUTS	This print is shared on a confidential basis subject to return upon demand by Osprea and nothing hereon may be reproduced, used or disclosed in whole or in part without the prior written permission of Osprea.	UNLESS OTHERWISE SPECIFIED DIMENSIONS ARE IN MILLIMETERS		REMOVE ALL SHARP EDGES AND BURRS	THIRD ANGLE PROJECTION	DRAWING NUMBER F_CHANNEL F-1
		GENERAL TOLERANCES LINEAR DIMENSIONS ALL OTHER FEATURE DIMENSION TOLERANCES ARE GOVERNED BY DIN ISO 2768-mK	LINEAR TO 3 : ±0.1 TO 6 : ±0.2 TO 30 : ±0.3 TO 120 : ±0.5 TO 400 : ±0.8 TO 1000 : ±1.2 TO 2000 : ±2.0			
		SHEET 6 OF 10		SIZE B		REVISION 2

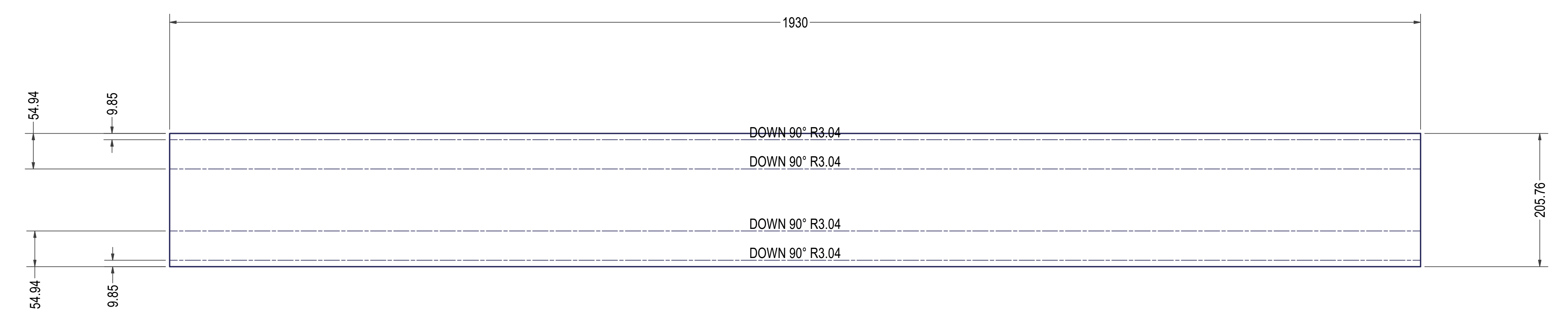
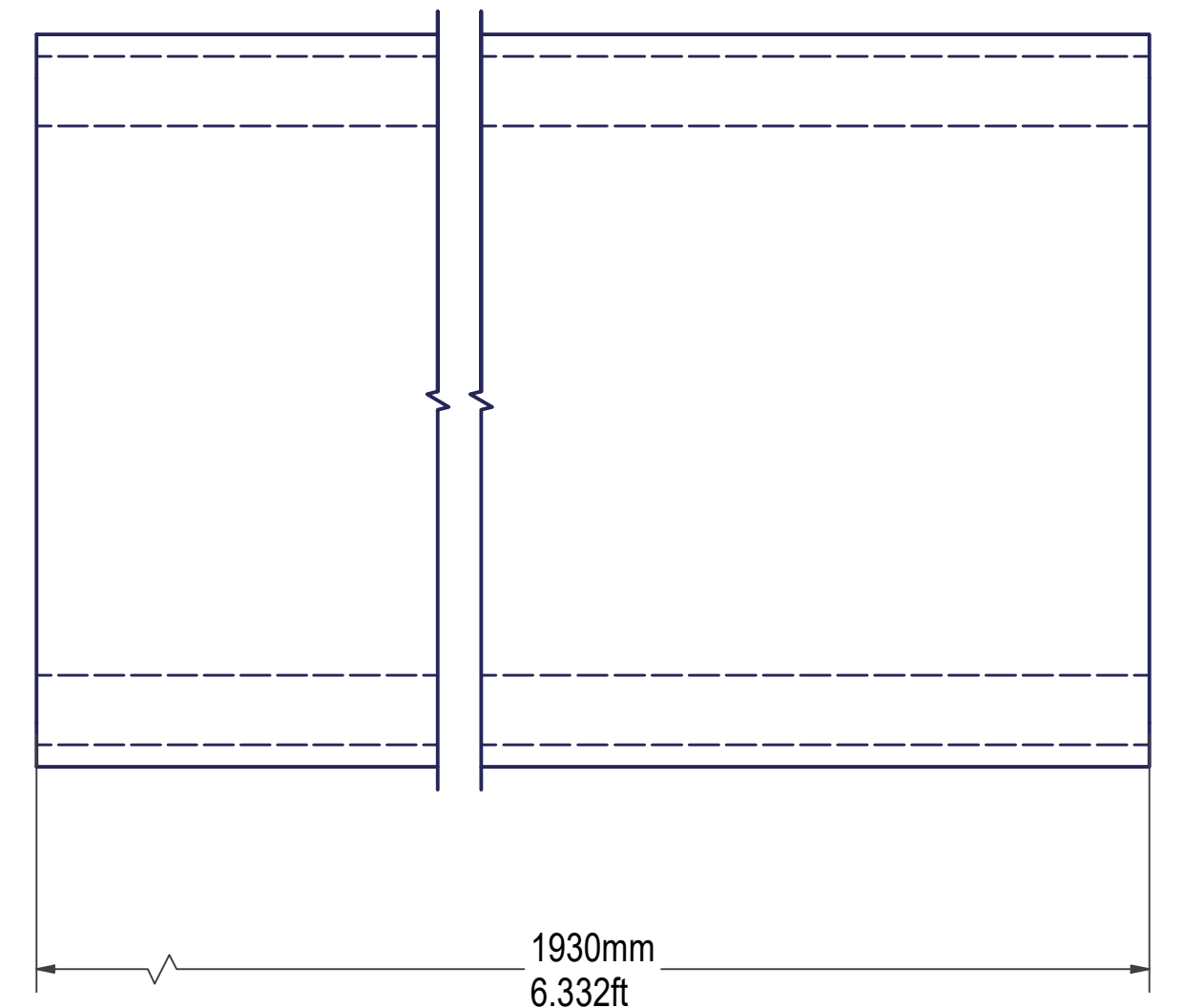
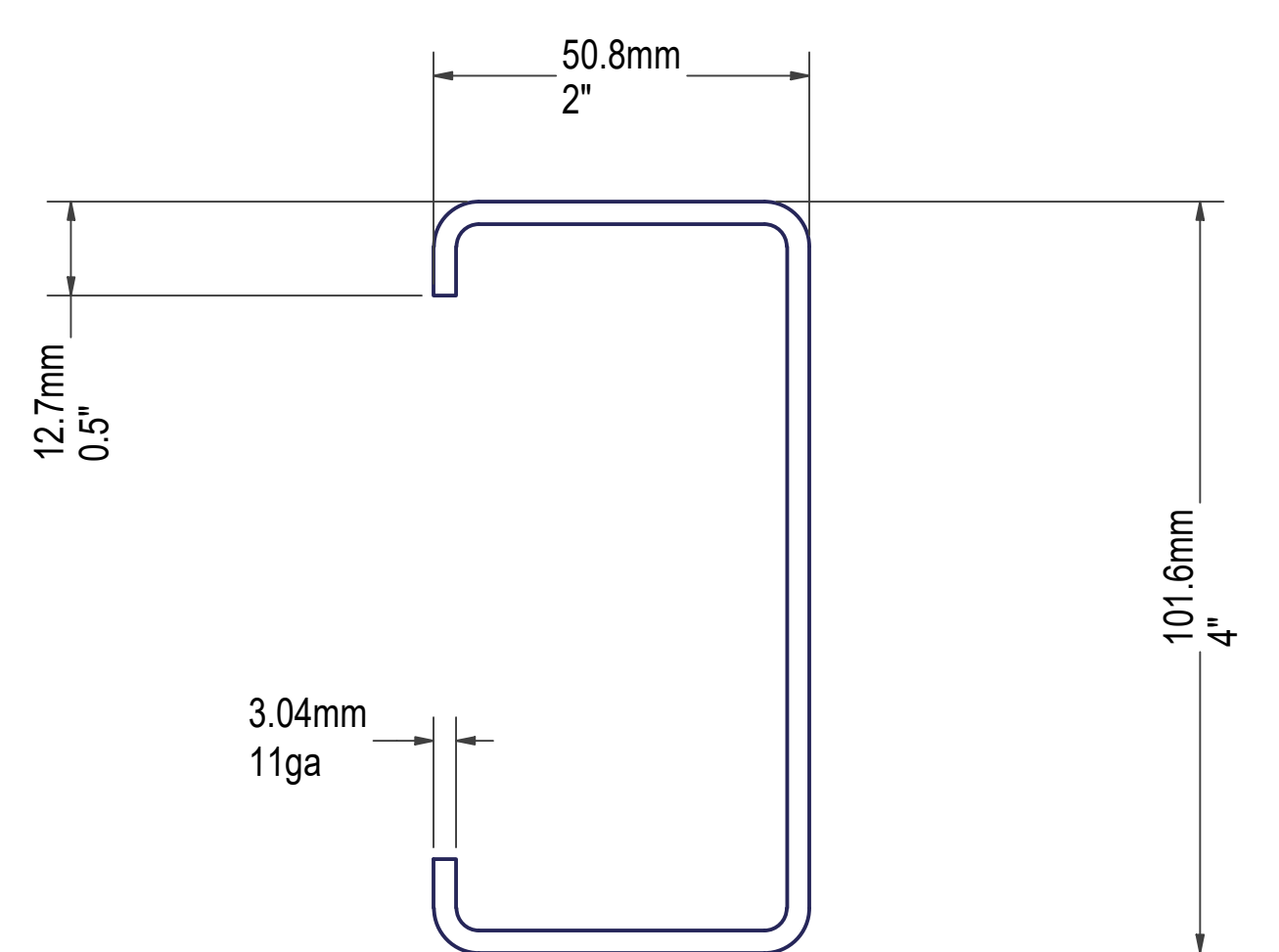

DXF FILE: CHANNEL F-2_1



DocuSigned by:
Robert L. Pennington
3/13/2022

Robert L. Pennington PE
7629 Mallow Road
Wilmington, NC 28411
Email: robert@RLPPE.com
Phone: 910-520-0278

ORIGINAL SCALE	UNLESS OTHERWISE STATED
COPYRIGHT	
This drawing and any information or descriptive matters contained therein are the copyright property of OSPREA LOGISTICS Ltd. Neither the whole nor any extract may be disclosed, loaned, copied, or used for manufacturing or tendering purposes without their written consent.	
MATERIAL	Steel ASTM A1011 CS Type B
THICK	3.038 mm
MASS	N/A
FINISH	NONE
ENGINEER	Dirk Genis
DRAWN	Dirk Genis
DATE	2/20/2022



TITLE
CHANNEL 2"x4"

FLAT PATTERN GEOMETRY IS GOVERNED BY DXF WITH THE EXPECTED TOLERANCE OF +/- 0.15mm ON ALL DXF CUTS		UNLESS OTHERWISE SPECIFIED DIMENSIONS ARE IN MILLIMETERS GENERAL TOLERANCES LINEAR DIMENSIONS: ALL OTHER FEATURE DIMENSION TOLERANCES ARE GOVERNED BY DIN ISO 2768-mK		REMOVE ALL SHARP EDGES AND BURRS	
LINEAR	0.5 TO 3	3 TO 6	6 TO 30	30 TO 120	120 TO 400
	±0.1	±0.2	±0.3	±0.5	±0.8
					±1.2
					±2.0
THIRD ANGLE PROJECTION		SHEET 7 OF 10		SIZE B REVISION 2	

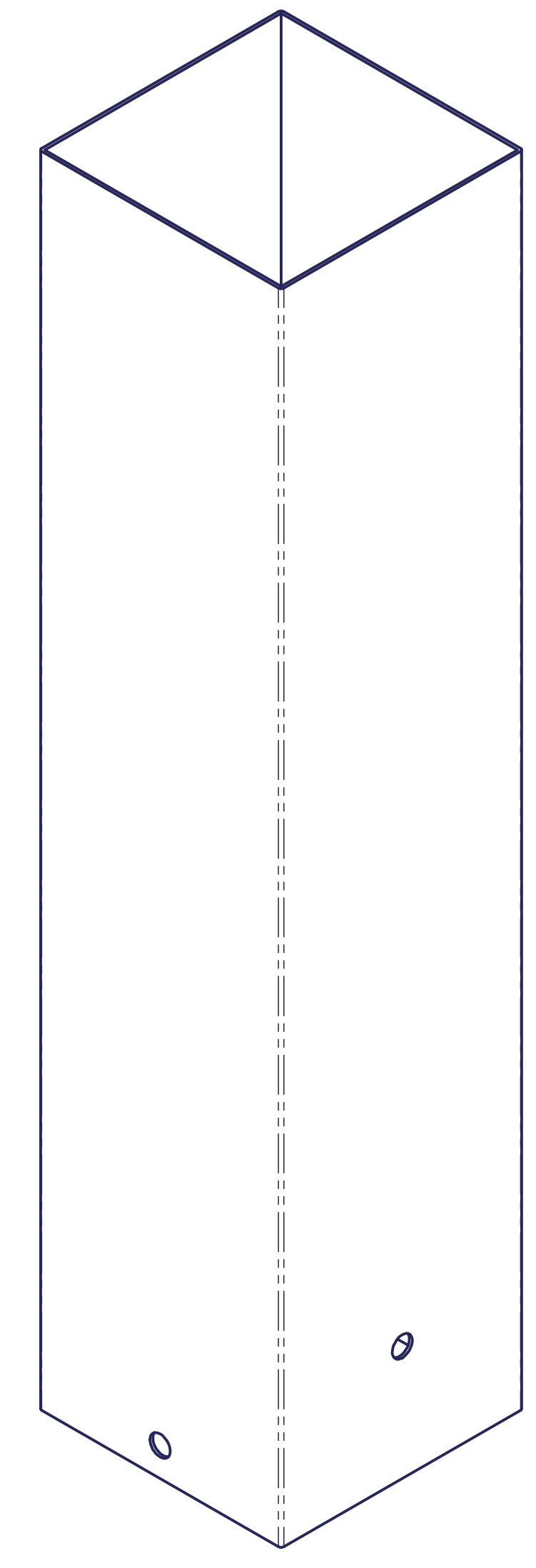
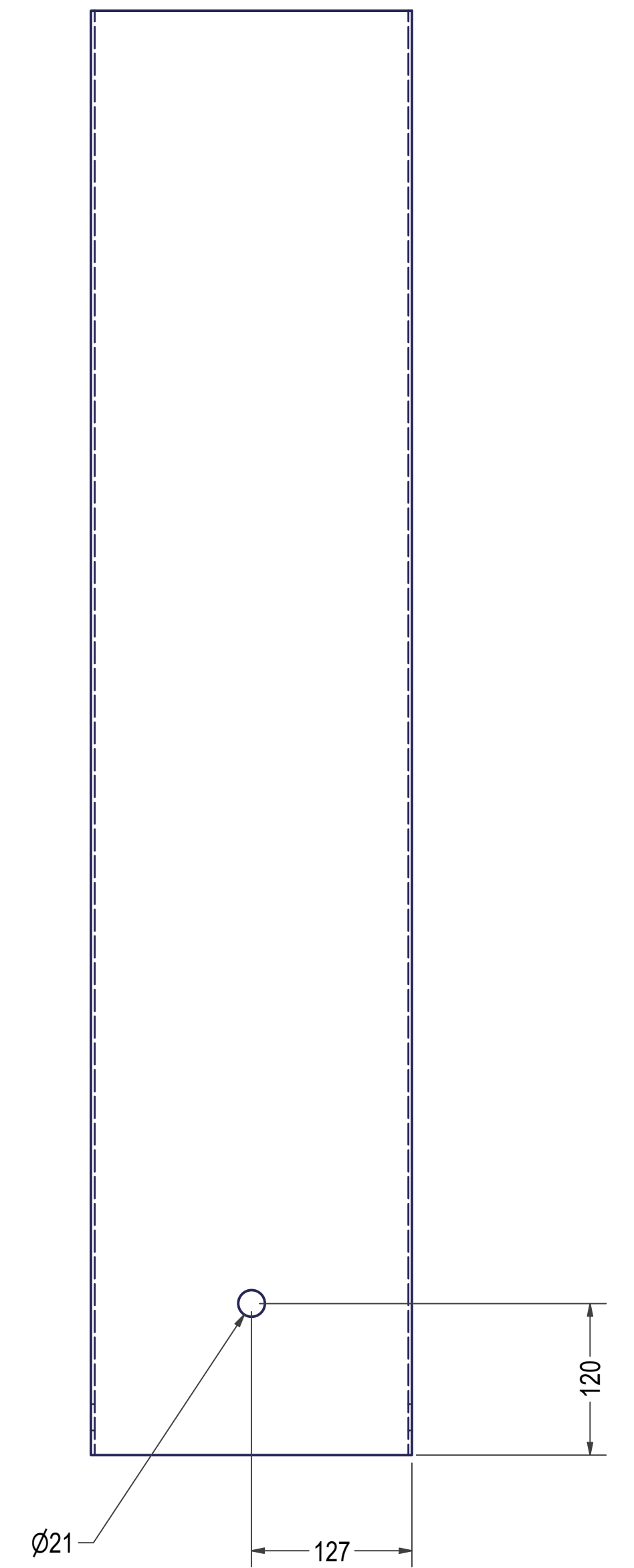
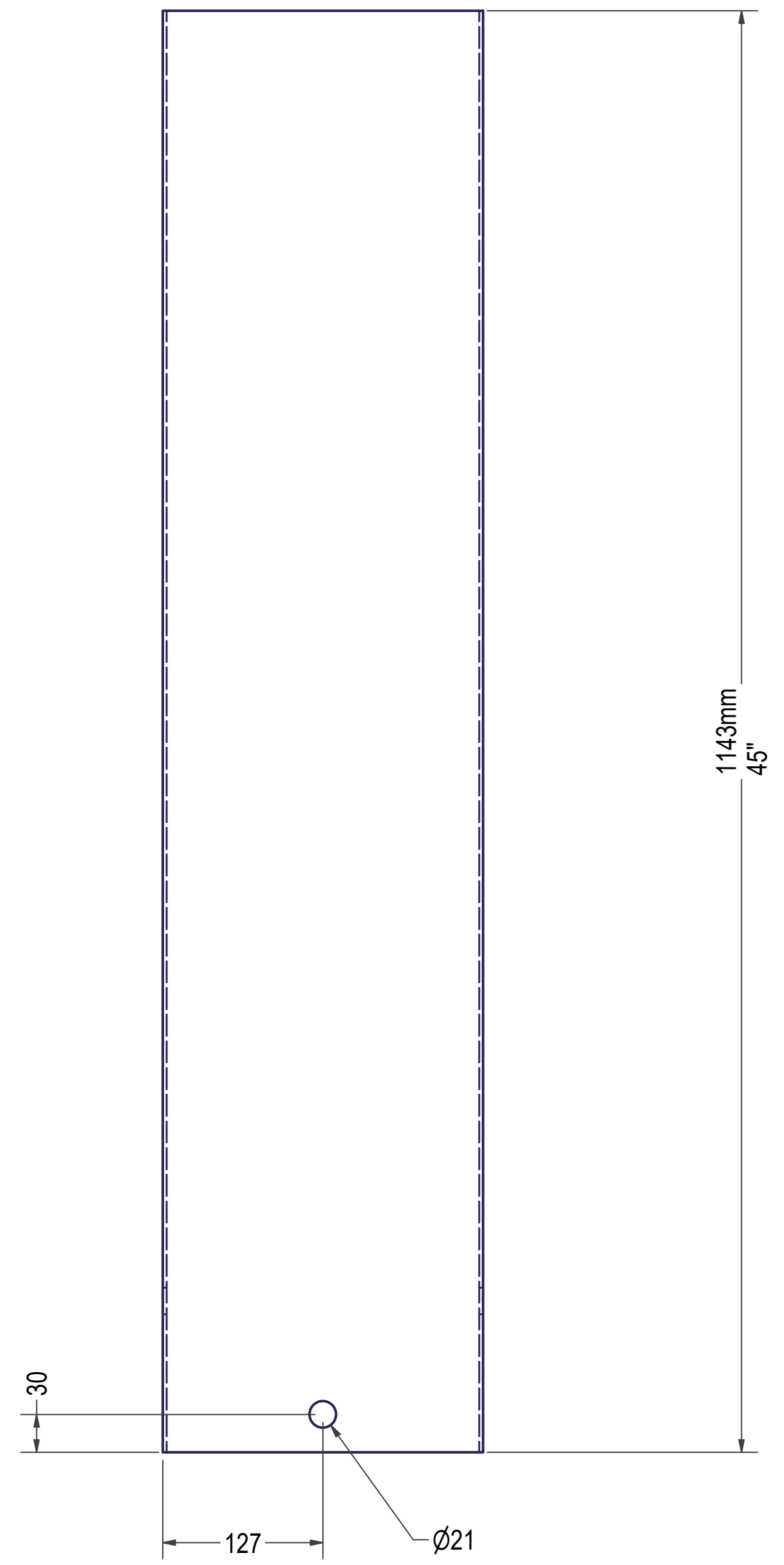
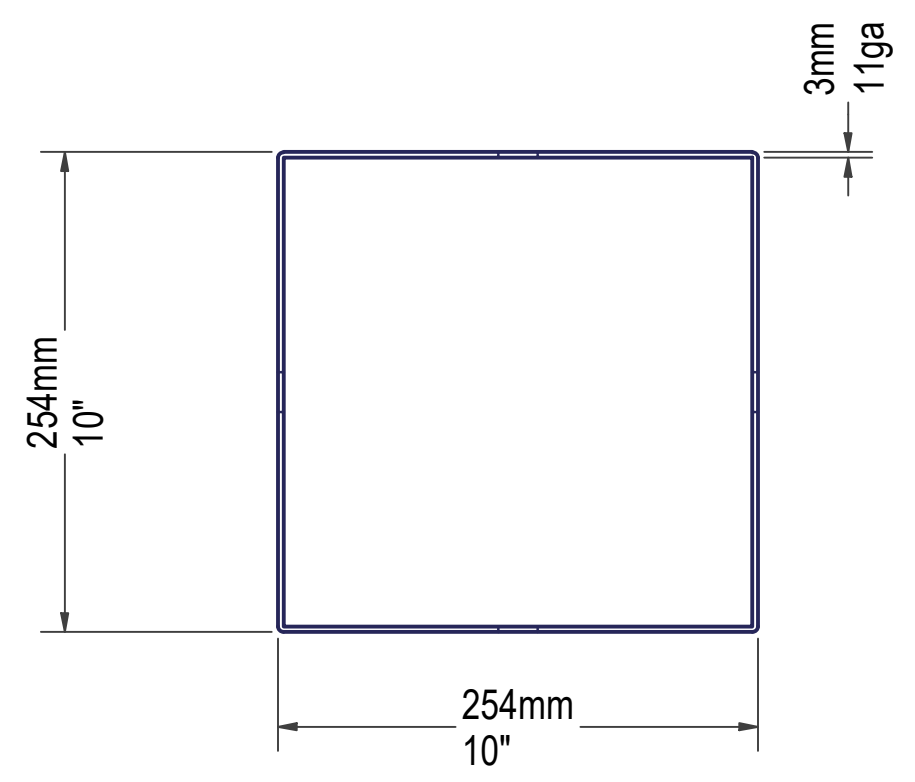

DocuSigned by:
Robert L. Pennington
0064399335DF452
3/13/2022

NORTH CAROLINA
PROFESSIONAL SEAL
25045
ENGINEER
ROBERT L. PENNINGTON

Robert L. Pennington PE
7629 Mallow Road
Wilmington, NC 28411
Email: robert@RLPPE.com
Phone: 910-520-0278

ORIGINAL SCALE	UNLESS OTHERWISE STATED
COPYRIGHT	
This drawing and any information or descriptive matters contained therein are the copyright property of OSPREA LOGISTICS Ltd. Neither the whole nor any extract may be disclosed, loaned, copied, or used for manufacturing or tendering purposes without their written consent.	
MATERIAL	Steel ASTM A500 GR B STRUCTURAL
THICK	
MASS	26.923 kg
FINISH	NONE
ENGINEER	Dirk Genis
DRAWN	Dirk Genis
DATE	2/20/2022



TITLE
TUBE PILLAR

FLAT PATTERN GEOMETRY IS GOVERNED BY DXF WITH THE EXPECTED TOLERANCE OF +/- 0.15mm ON ALL DXF CUTS This print is shared on a confidential basis subject to return upon demand by Osprea and nothing herein may be reproduced, used or disclosed in whole or in part without the prior written permission of Osprea.	UNLESS OTHERWISE SPECIFIED DIMENSIONS ARE IN MILLIMETERS GENERAL TOLERANCES LINEAR DIMENSIONS		REMOVE ALL SHARP EDGES AND BURRS THIRD ANGLE PROJECTION
	LINEAR TO : 0.5 TO : 3 TO : 6 TO : 30 TO : 60 TO : 120 TO : 240 TO : 480 TO : 960 TO : 1920	DIMENSION TOLERANCES ARE GOVERNED BY DIN ISO 2768-mK	
DRAWING NUMBER TUBE PILLAR			SHEET 9 OF 10 SIZE: B REVISION: 2

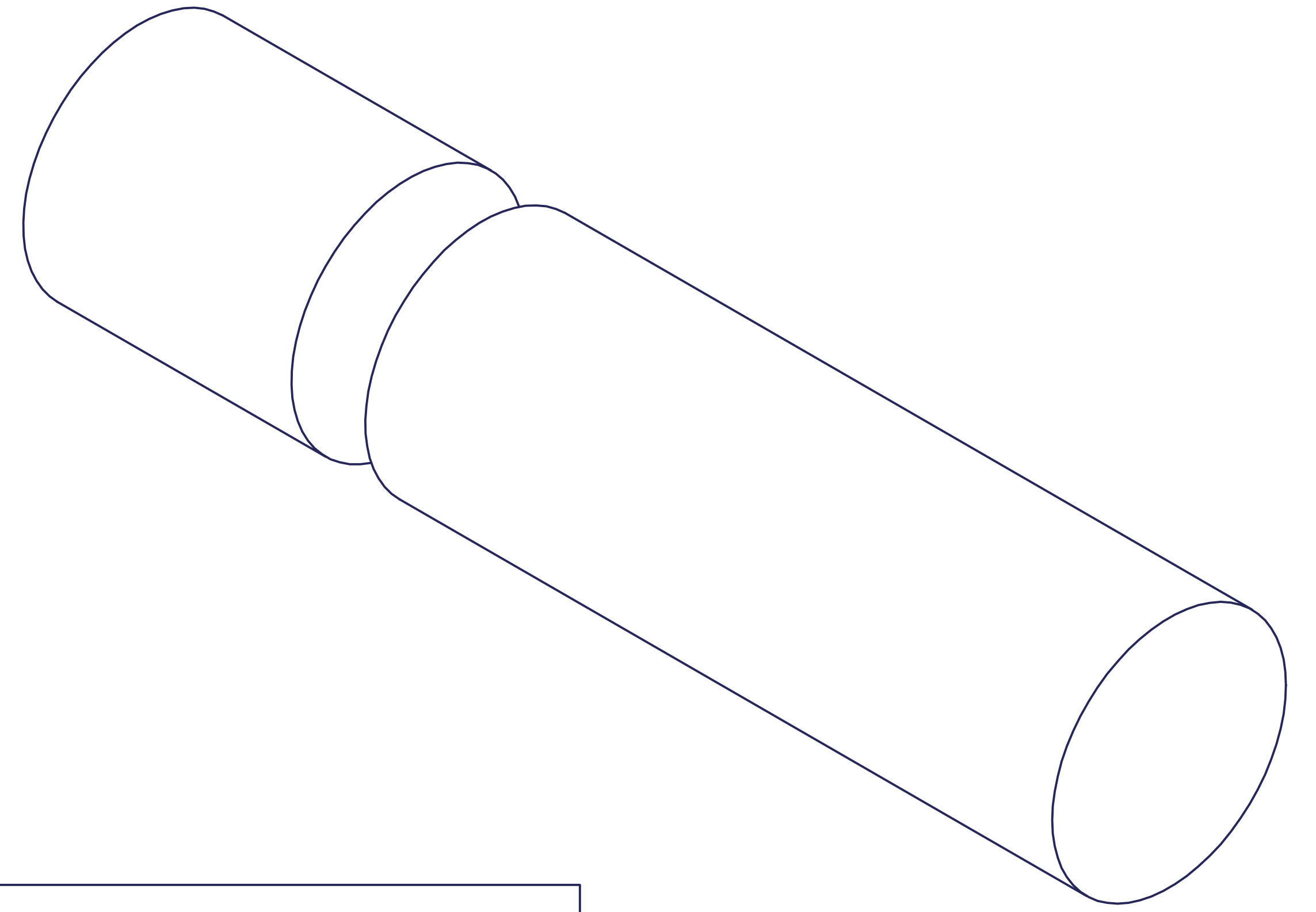
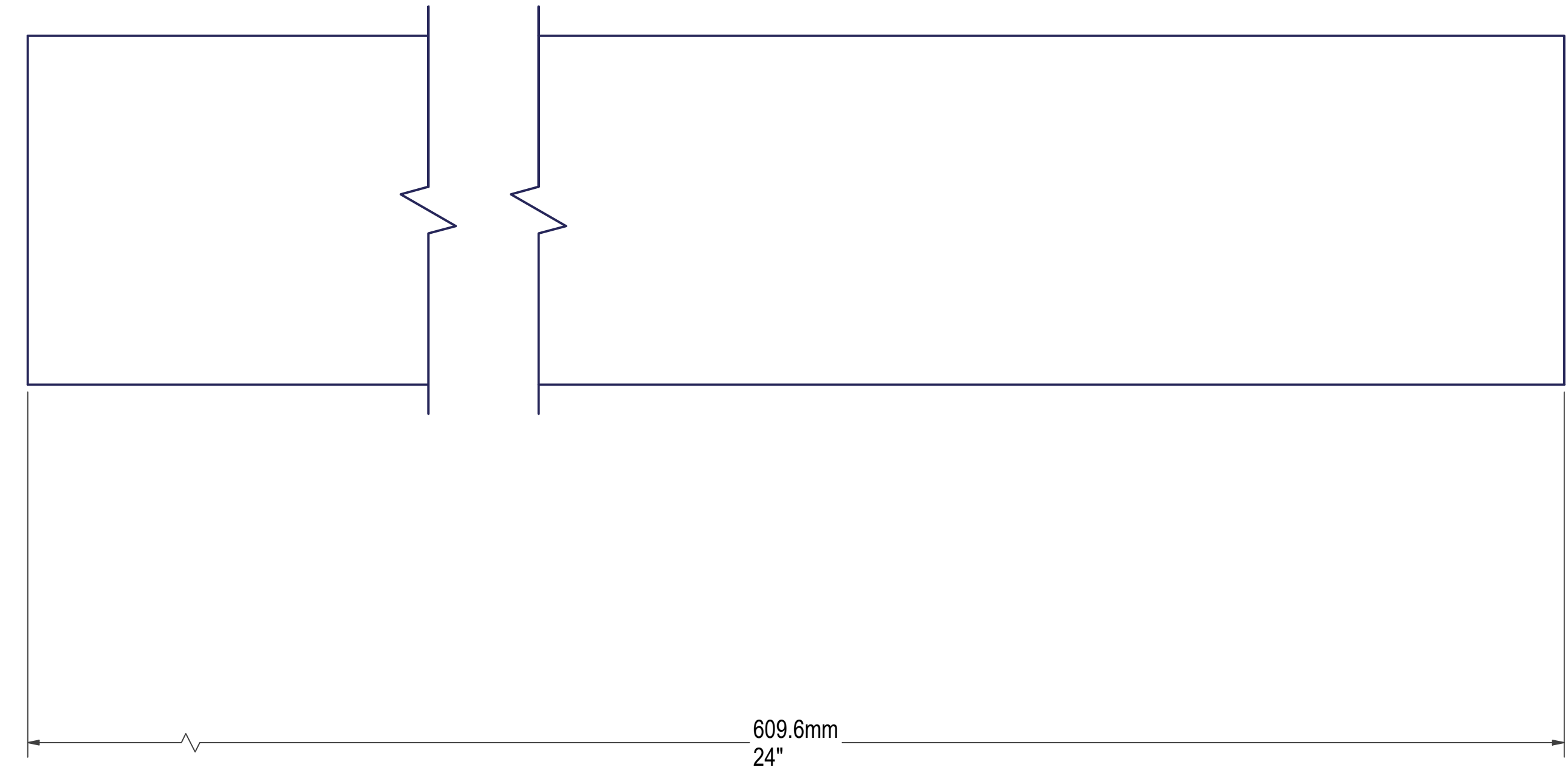
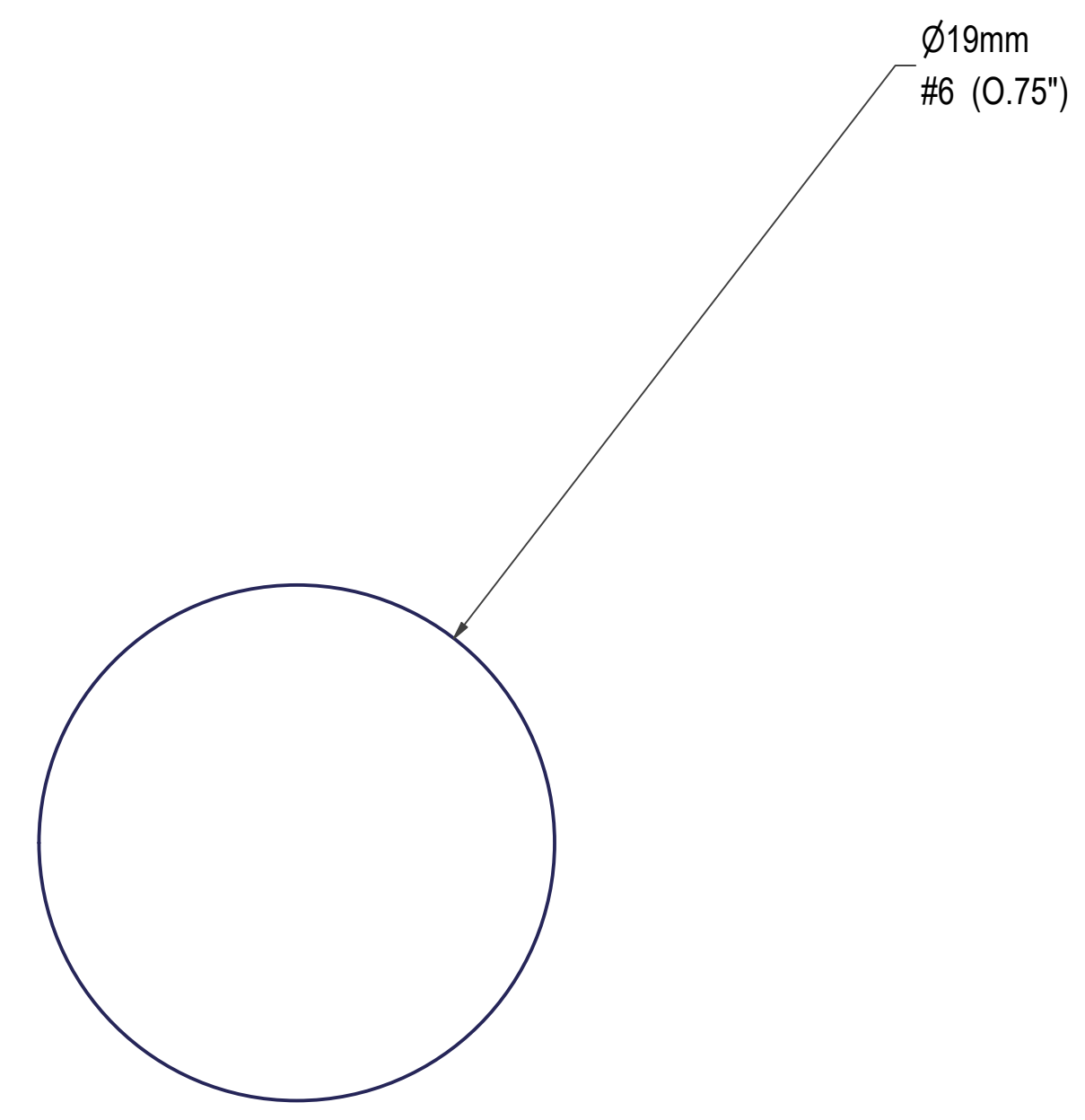

MATERIAL: CARBON STEEL ASTM 615

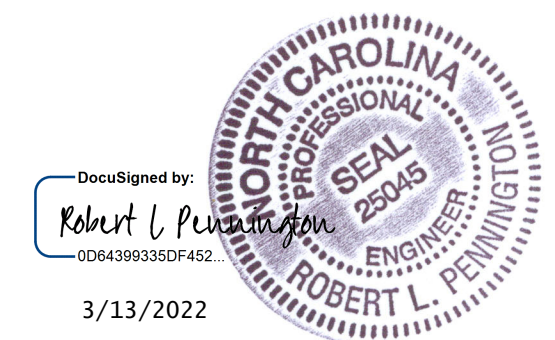

Robert L. Pennington PE
 7629 Mallow Road
 Wilmington, NC 28411
 Email: robert@RLPPE.com
 Phone: 910-520-0278

ORIGINAL SCALE	UNLESS OTHERWISE STATED
COPYRIGHT	
This drawing and any information or descriptive matters contained therein are the copyright property of OSPREA LOGISTICS Ltd. Neither the whole nor any extract may be disclosed, loaned, copied, or used for manufacturing or tendering purposes without their written consent.	
MATERIAL	Generic
THICK	
MASS	0.173 kg
FINISH	NONE
ENGINEER	Dirk Genis
DRAWN	Dirk Genis
DATE	2/20/2022



TITLE
RUBAR #6 (0.75" ,19MM)

FLAT PATTERN GEOMETRY IS GOVERNED BY DXF WITH THE EXPECTED TOLERANCE OF +/- 0.15mm ON ALL DXF CUTS

This print is shared on a confidential basis subject to return upon demand by Osprea and nothing hereon may be reproduced, used or disclosed in whole or in part without the prior written permission of Osprea.

UNLESS OTHERWISE SPECIFIED DIMENSIONS ARE IN MILLIMETERS									
GENERAL TOLERANCES LINEAR DIMENSIONS									
LINEAR	0.5 TO 3	3 TO 6	6 TO 10	10 TO 30	30 TO 120	120 TO 400	400 TO 1000	1000 TO 2000	2000 TO 4000
±0.1	±0.1	±0.2	±0.3	±0.5	±0.8	±1.2	±2.0		

REMOVE ALL SHARP EDGES AND BURRS
 THIRD ANGLE PROJECTION
 DRAWING REBAR PILLAR SECTION
 SHEET 10 OF 10
 SIZE: B
 REVISION: 2