

ITEM	QTY	PART NUMBER	BOM	DESCRIPTION
1	2	JIG FRAME ASSY-FOUND-S1	JIGGING ASSEMBLY 40FT	
2	2	JIG FRAME ASSY-FOUND-S2	JIGGING ASSEMBLY MODEL1 - 10FT SPACING	

ZONE	REV	DESCRIPTION	ENG	DATE
	1			2/20/2022

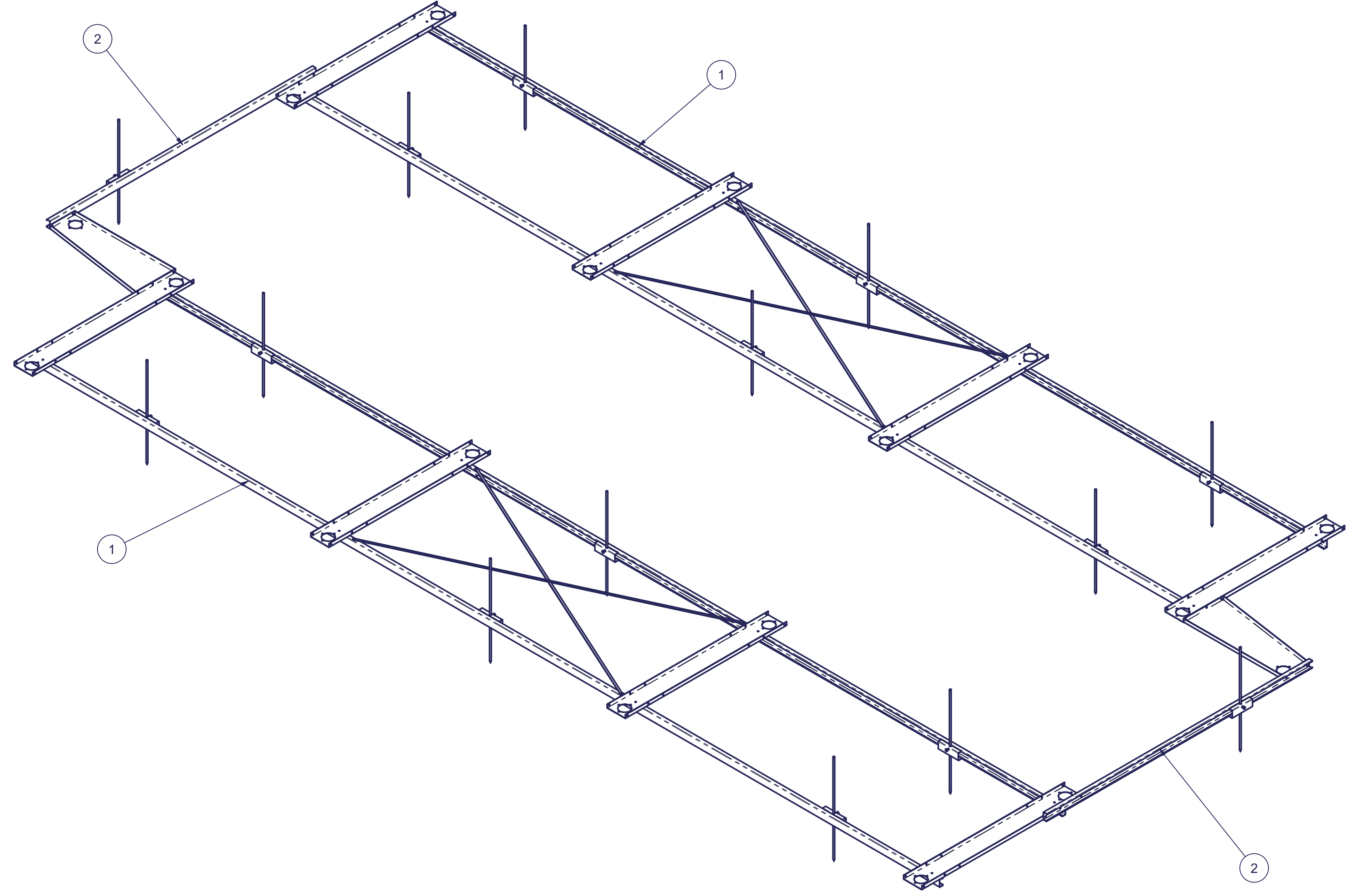
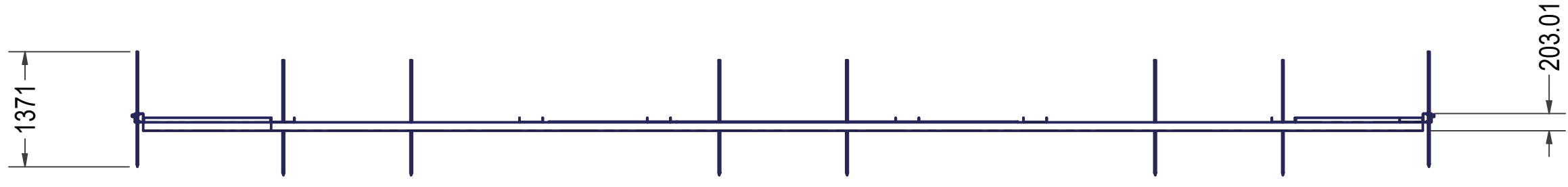
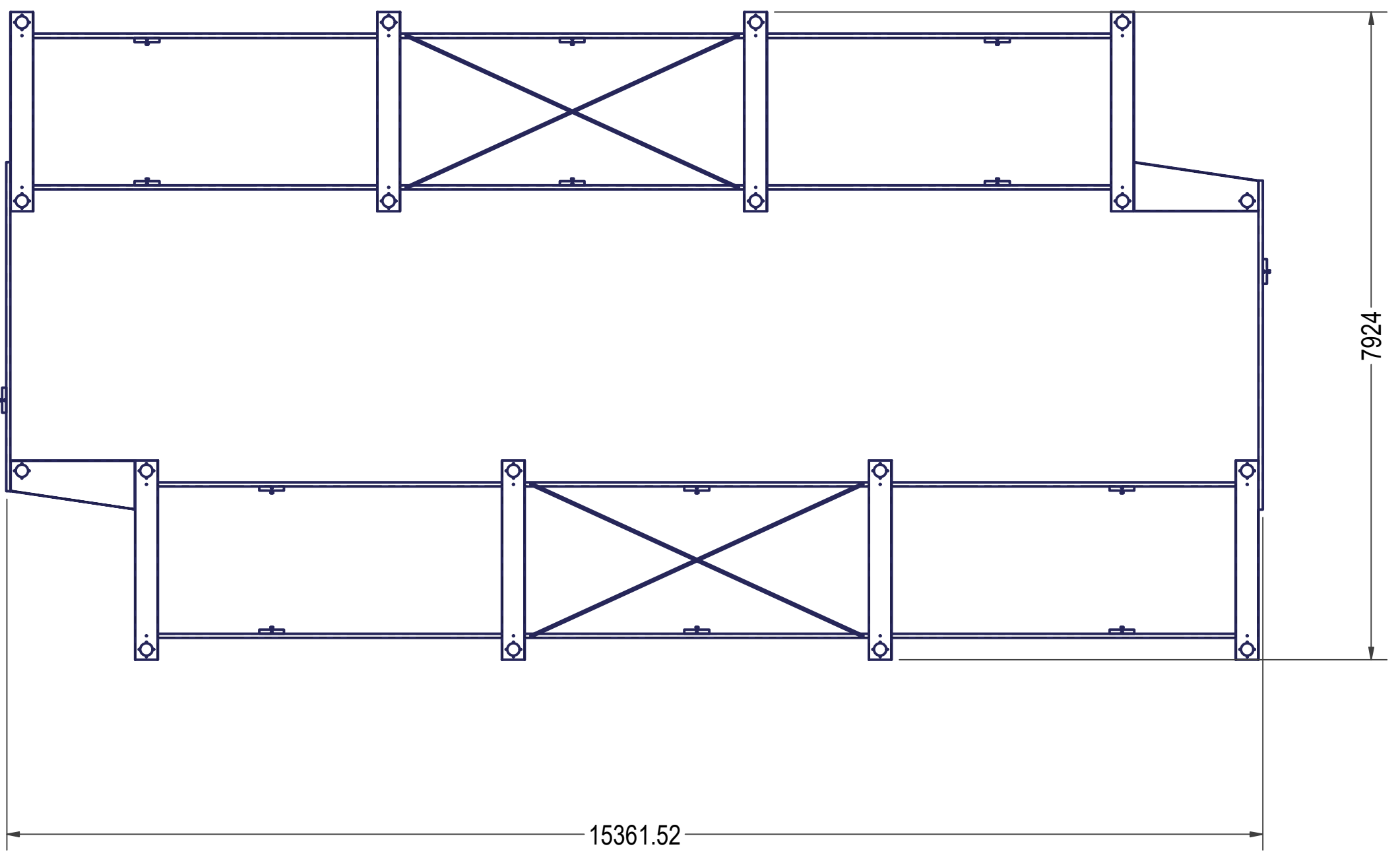

ORIGINAL SCALE UNLESS OTHERWISE STATED

COPYRIGHT

This drawing and any information or descriptive matters contained therein are the copyright property of SELF SUSTAINABLE SOLUTIONS. Neither the whole nor any extract may be disclosed, loaned, copied, or used for manufacturing or tendering purposes without their written consent.

MATERIAL	
THICK	
MASS	N/A
FINISH	NONE
ENGINEER	Dirk Genis
DRAWN	Dirk Genis
DATE	2/20/2022



Robert L. Pennington PE
7629 Mallow Road
Wilmington, NC 28411
Email: robert@RLPPE.com
Phone: 910-520-0278



FLAT PATTERN GEOMETRY IS GOVERNED BY DXF WITH THE EXPECTED TOLERANCE OF +/- 0.15mm ON ALL DXF CUTS

This print is shared on a confidential basis subject to return upon demand by SSS and nothing herein may be reproduced, used or disclosed in whole or in part without the prior written permission of Osprea.

UNLESS OTHERWISE SPECIFIED DIMENSIONS ARE IN MILLIMETERS	
GENERAL TOLERANCES LINEAR DIMENSIONS	
LINEAR	ALL OTHER FEATURE
0.5 TO 1	±0.1
1 TO 2	±0.2
2 TO 5	±0.3
5 TO 10	±0.4
10 TO 20	±0.5
20 TO 50	±0.6
50 TO 100	±0.8
100 TO 200	±1.0
200 TO 500	±1.2
500 TO 1000	±1.5
1000 TO 2000	±2.0
2000 TO 4000	±2.5
4000 TO 10000	±3.0

REMOVE ALL SHARP EDGES AND BURRS

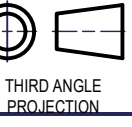

TITLE
CHICKADEE, JIGGING ASSEMBLY

DRAWING NUMBER
CHICKADEE_JIG_ASSY FOUND

SHEET 1 OF 14 SIZE: B REVISION: 1

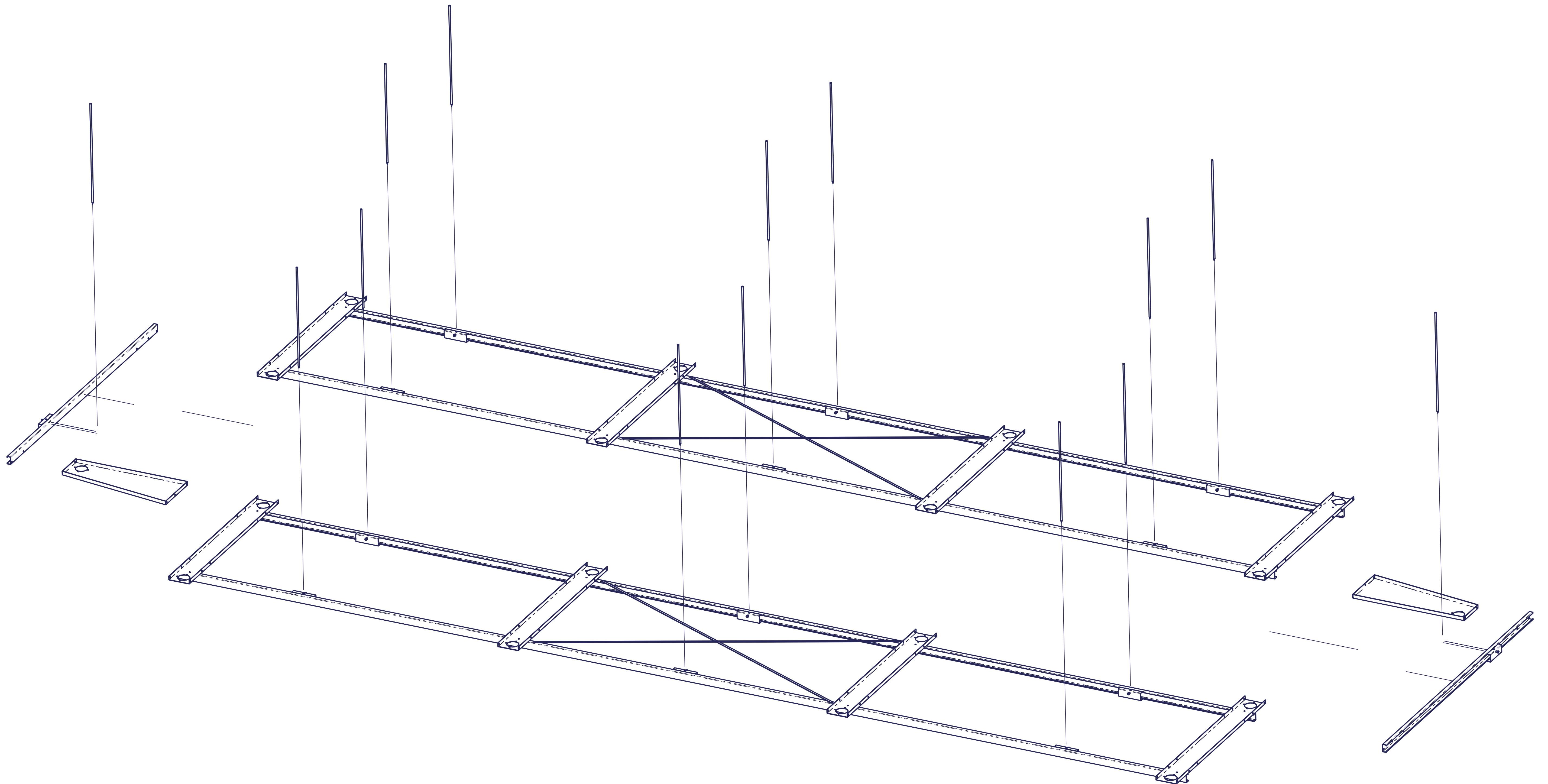

SUB ASSEMBLY BREAK DOWN FOR TRANSPORT

DocuSigned by:
 Robert L. Pennington
 026439933530F452
 3/13/2022

Robert L. Pennington PE
 7629 Mallow Road
 Wilmington, NC 28411
 Email: robert@RLPPE.com
 Phone: 910-520-0278

ORIGINAL SCALE	UNLESS OTHERWISE STATED
COPYRIGHT	
This drawing and any information or descriptive matters contained therein are the copyright property of SELF SUSTAINABLE SOLUTIONS. Neither the whole nor any extract may be disclosed, loaned, copied, or used for manufacturing or tendering purposes without their written consent.	
MATERIAL	
THICK	
MASS	N/A
FINISH	NONE
ENGINEER	Dirk Genis
DRAWN	Dirk Genis
DATE	2/20/2022



FLAT PATTERN GEOMETRY IS GOVERNED BY DXF WITH THE EXPECTED TOLERANCE OF +/- 0.15mm ON ALL DXF CUTS		This print is shared on a confidential basis subject to return upon demand by SSS and nothing herein may be reproduced, used or disclosed in whole or in part without the prior written permission of Osprea.	UNLESS OTHERWISE SPECIFIED DIMENSIONS ARE IN MILLIMETERS GENERAL TOLERANCES LINEAR DIMENSIONS ALL OTHER FEATURE DIMENSION TOLERANCES ARE GOVERNED BY DIN ISO 2768-mK	REMOVE ALL SHARP EDGES AND BURRS	THIRD ANGLE PROJECTION	DRAWING NUMBER CHICKADEE_JIG_ASSY FOUND	SHEET 2 OF 14 SIZE: B REVISION: 1
--	--	---	---	----------------------------------	------------------------	---	---

TITLE
 CHICKADEE, JIGGING ASSEMBLY

BOM			
ITEM	QTY	PART NUMBER	DESCRIPTION
1	4	PLATE J-1	PLATE JIGGING
2	2	CHANNEL J-1	CHANNEL 2"x4"
3	6	LOCK ASSY ANCHOR STAKE	LOCK ASSEMBLY
4	2	STRIP CROSS BRACE	PLATE CROSS BRACE

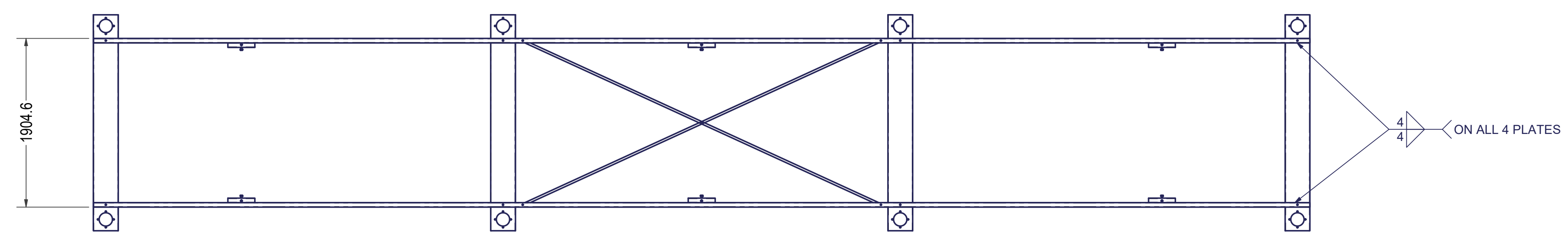
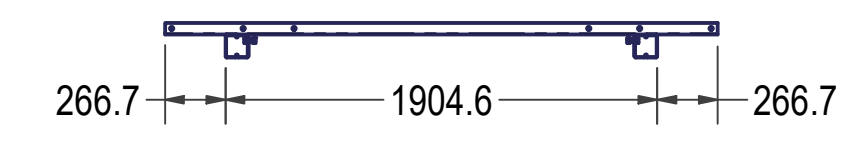
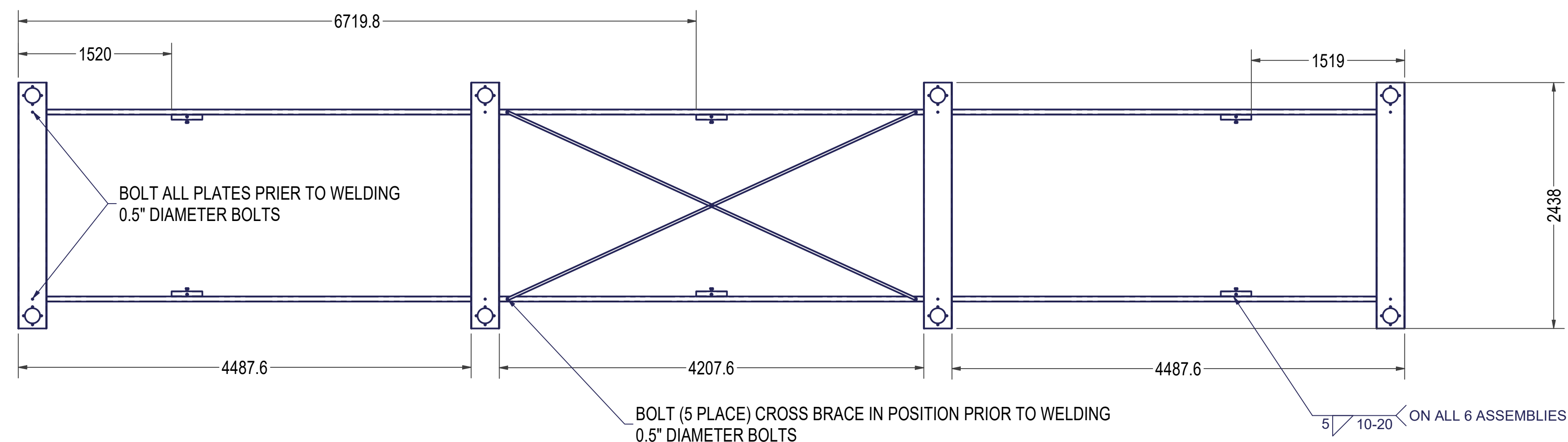
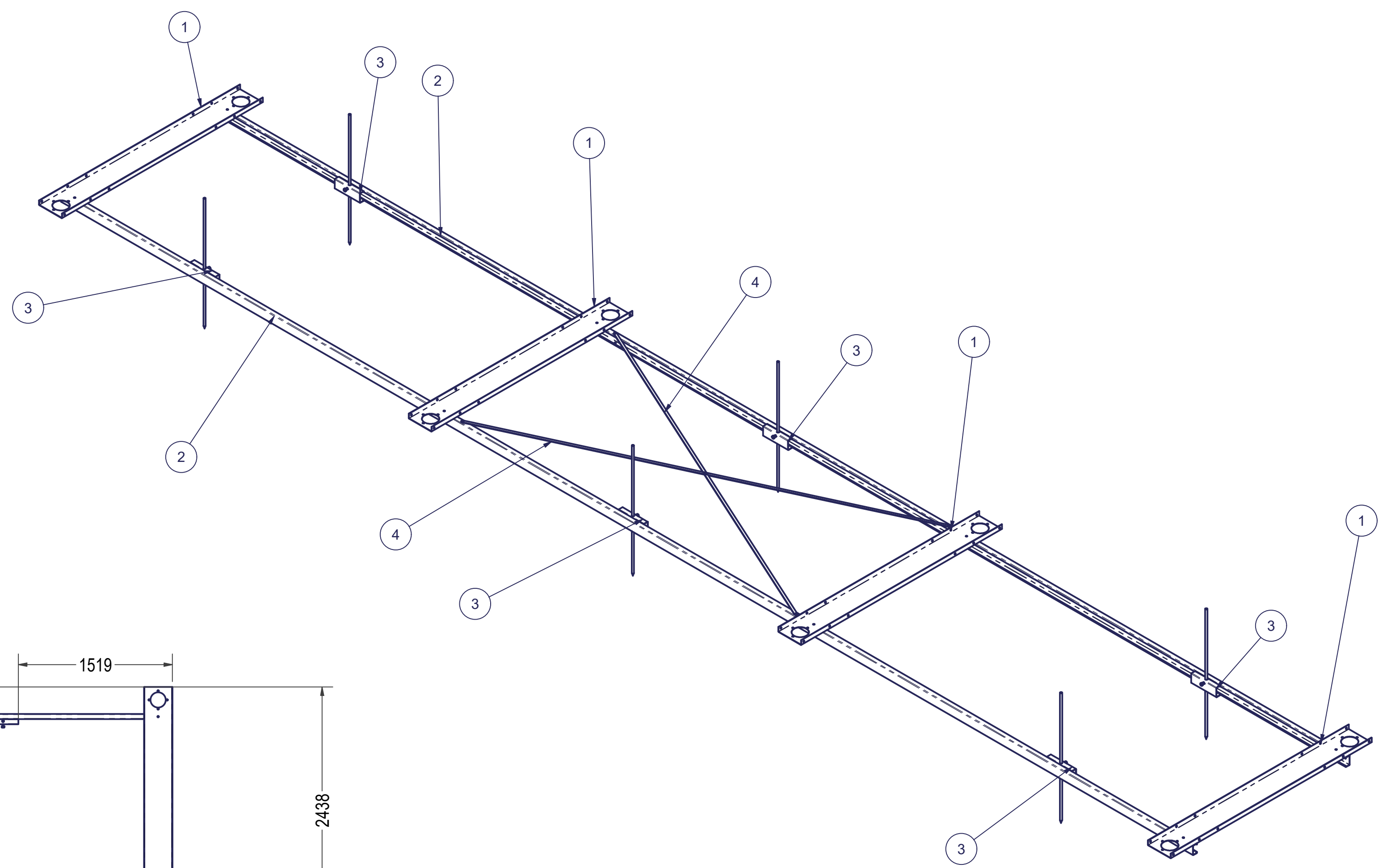

ORIGINAL SCALE UNLESS OTHERWISE STATED

COPYRIGHT

This drawing and any information or descriptive matters contained therein are the copyright property of SELF SUSTAINABLE SOLUTIONS. Neither the whole nor any extract may be disclosed, loaned, copied, or used for manufacturing or tendering purposes without their written consent.

MATERIAL	
THICK	
MASS	N/A
FINISH	NONE
ENGINEER	Dirk Genis
DRAWN	Dirk Genis
DATE	2/20/2022

DocuSigned by:
Robert L. Pennington
0084969335DF452
3/13/2022

ROBERT L. PENNINGTON
NORTH CAROLINA PROFESSIONAL SEAL 2006
ENGINEER

Robert L. Pennington PE
7629 Mallow Road
Wilmington, NC 28411
Email: robert@RLPPE.com
Phone: 910-520-0278



<p>FLAT PATTERN GEOMETRY IS GOVERNED BY DXF WITH THE EXPECTED TOLERANCE OF +/- 0.15mm ON ALL DXF CUTS</p> <p>This print is shared on a confidential basis subject to return upon demand by SSS and nothing herein may be reproduced, used or disclosed in whole or in part without the prior written permission of Osprea.</p>	<p>UNLESS OTHERWISE SPECIFIED DIMENSIONS ARE IN MILLIMETERS</p> <p>GENERAL TOLERANCES LINEAR DIMENSIONS</p> <table border="1"> <tr> <th>LINEAR</th> <th>0.5 TO 3</th> <th>3 TO 8</th> <th>8 TO 30</th> <th>30 TO 120</th> <th>120 TO 400</th> <th>400 TO 1000</th> <th>1000 TO 2000</th> <th>2000 TO 4000</th> </tr> <tr> <td>±</td> <td>0.1</td> <td>±0.2</td> <td>±0.3</td> <td>±0.5</td> <td>±0.8</td> <td>±1.2</td> <td>±2.0</td> <td>±3.0</td> </tr> </table> <p>ALL OTHER FEATURES GOVERNED BY DIMENSION TOLERANCES ARE GOVERNED BY DIN ISO 2768-mK</p>	LINEAR	0.5 TO 3	3 TO 8	8 TO 30	30 TO 120	120 TO 400	400 TO 1000	1000 TO 2000	2000 TO 4000	±	0.1	±0.2	±0.3	±0.5	±0.8	±1.2	±2.0	±3.0	<p>REMOVE ALL SHARP EDGES AND BURRS</p> <p>THIRD ANGLE PROJECTION</p>	<p>DRAWING NUMBER: JIG FRAME</p> <p>ASSY.FOUND.S1</p> <p>SHEET 3 OF 14 SIZE: B REVISION: 1</p>
		LINEAR	0.5 TO 3	3 TO 8	8 TO 30	30 TO 120	120 TO 400	400 TO 1000	1000 TO 2000	2000 TO 4000											
±	0.1	±0.2	±0.3	±0.5	±0.8	±1.2	±2.0	±3.0													
<p>TITLE: JIGGING ASSEMBLY 40FT</p>																					

ITEM	QTY	PART NUMBER	BOM	DESCRIPTION
1	1	CHANNEL J-2		CHANNEL Z7X4"
2	1	AS 2465 - 5/8 UNC		Unified hexagon bolts, screws and nuts (UNC and UNF threads)
3	1	AS 2465 - 5/8 x 1 1/2 UNC		Unified hexagon bolts, screws and nuts (UNC and UNF threads)
4	1	REBAR #6 X 4.5FT		REBAR #6

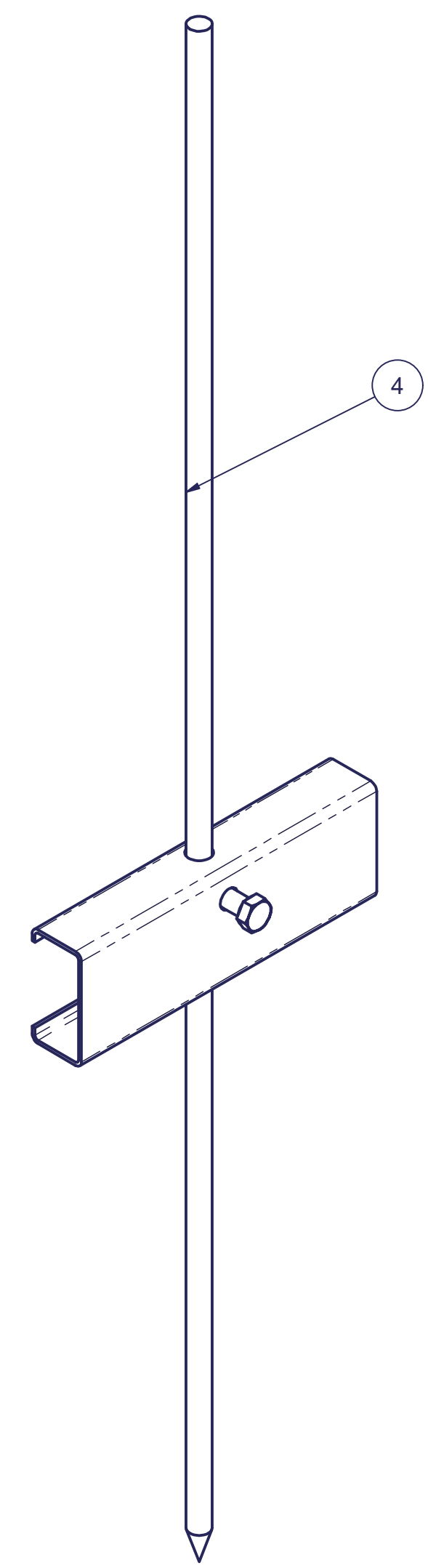
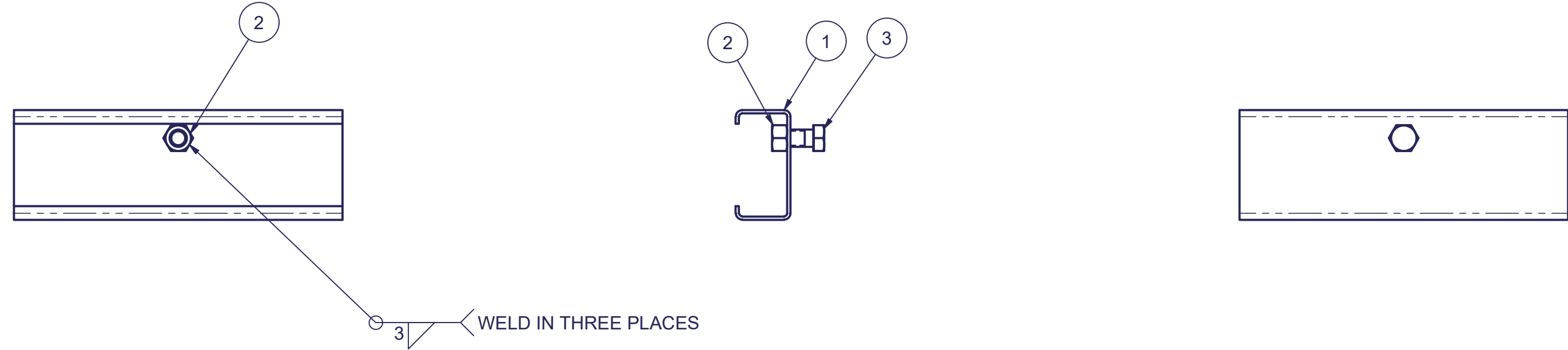

DocuSigned by:
Robert L. Pennington
 0064399335CF452
 3/13/2022

ROBERT L. PENNINGTON
 PROFESSIONAL ENGINEER
 SEAL
 PE0418
 NORTH CAROLINA
 ENGINEER
 ROBERT L. PENNINGTON, N.C.

Robert L. Pennington PE
 7629 Mallow Road
 Wilmington, NC 28411
 Email: robert@RLPPE.com
 Phone: 910-520-0278

ORIGINAL SCALE	UNLESS OTHERWISE STATED
COPYRIGHT	
This drawing and any information or descriptive matters contained therein are the copyright property of SELF SUSTAINABLE SOLUTIONS. Neither the whole nor any extract may be disclosed, loaned, copied, or used for manufacturing or tendering purposes without their written consent.	
MATERIAL	
THICK	
MASS	N/A
FINISH	NONE
ENGINEER	Dirk Genis
DRAWN	Dirk Genis
DATE	2/20/2022



FLAT PATTERN GEOMETRY IS GOVERNED BY DXF WITH THE EXPECTED TOLERANCE OF +/- 0.15mm ON ALL DXF CUTS		This print is shared on a confidential basis subject to return upon demand by SSS and nothing herein may be reproduced, used or disclosed in whole or in part without the prior written permission of Osprey.		UNLESS OTHERWISE SPECIFIED DIMENSIONS ARE IN MILLIMETERS GENERAL TOLERANCES LINEAR DIMENSIONS: ALL OTHER FEATURE DIMENSION TOLERANCES ARE GOVERNED BY DIN ISO 2768-mK		REMOVE ALL SHARP EDGES AND BURRS		THIRD ANGLE PROJECTION		LOCK ASSY ANCHOR STAKE SHEET 4 OF 14 SIZE: B REVISION: 1	
LINEAR	0.5 TO 3	3 TO 6	6 TO 30	30 TO 120	120 TO 400	400 TO 1000	1000 TO 2000	2000 TO 4000	4000 TO 6000	6000 TO 10000	10000 TO 20000
	±0.1	±0.1	±0.2	±0.3	±0.5	±0.8	±1.2	±2.0			

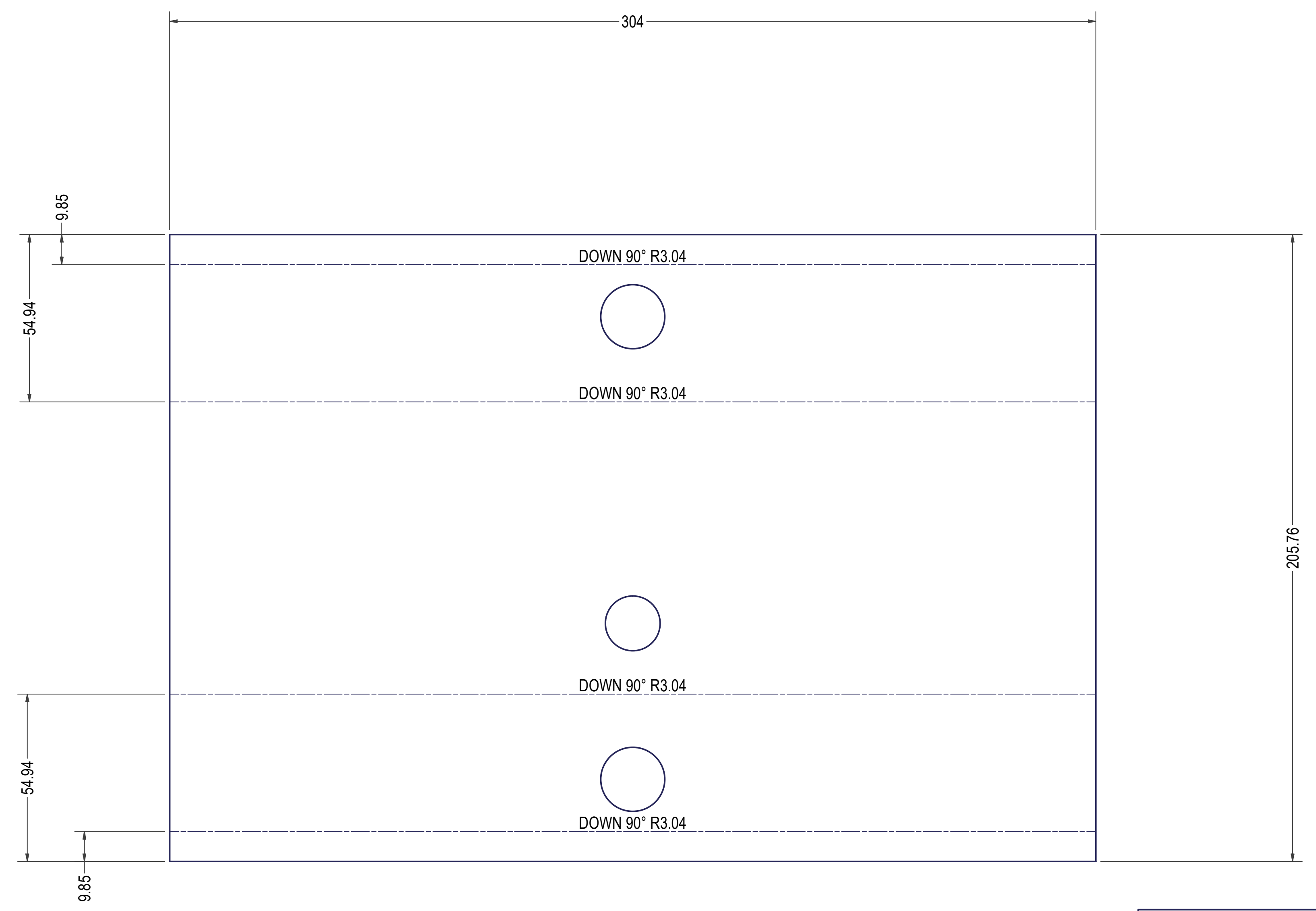
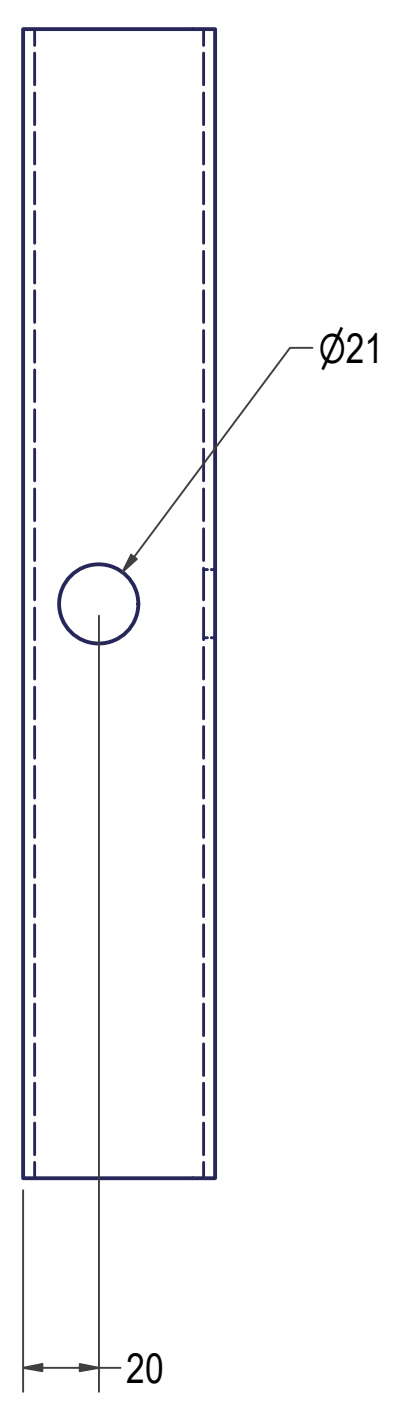
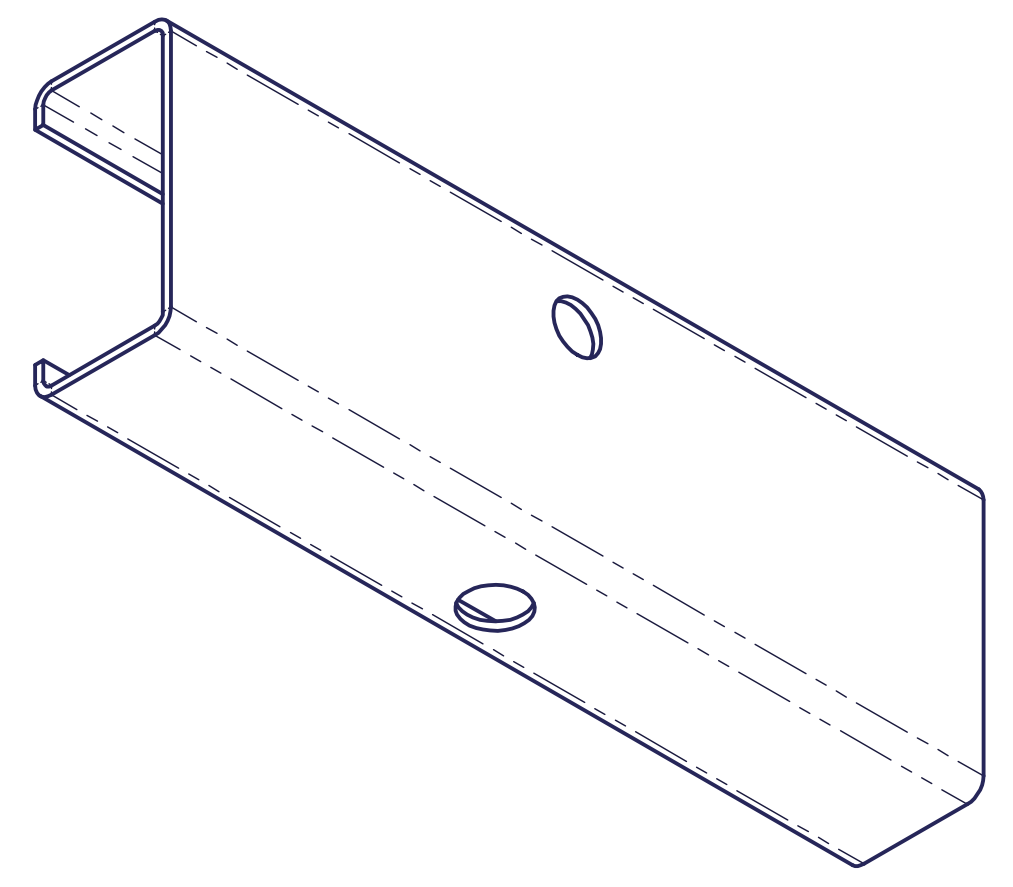
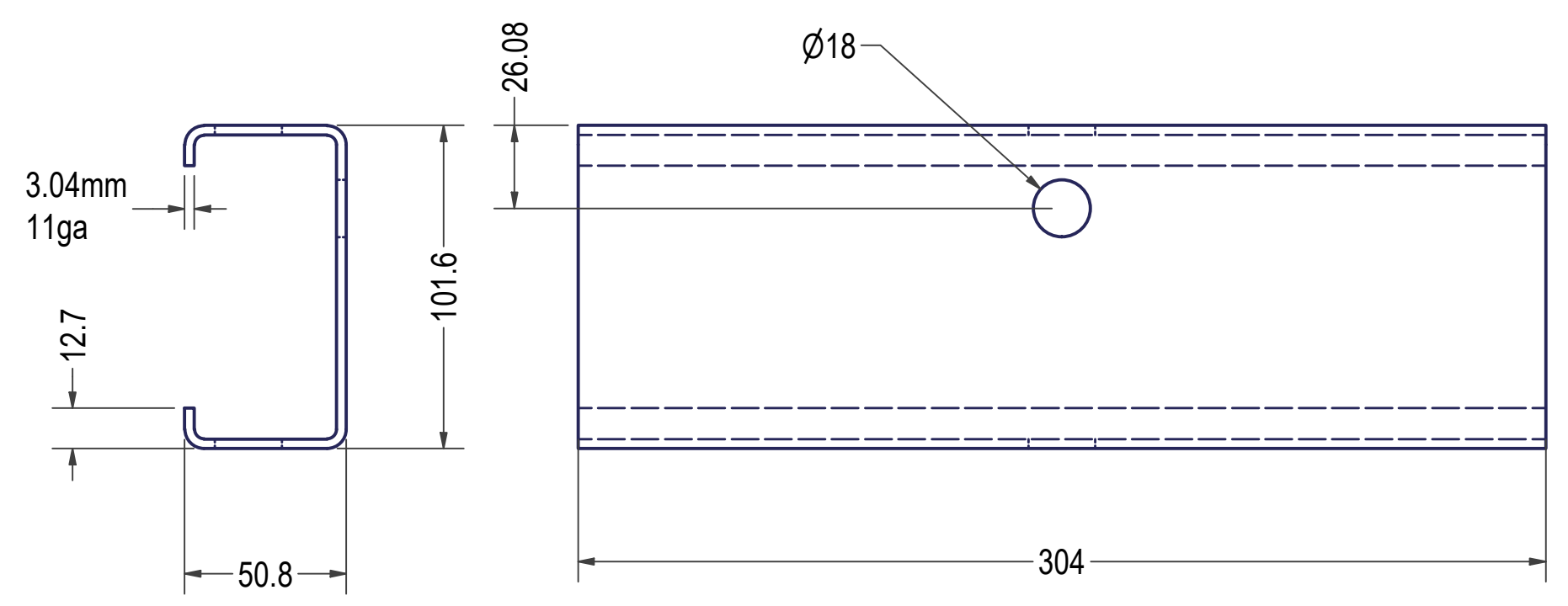

DXF FILE: CHANNEL J-2_1

ORIGINAL SCALE	UNLESS OTHERWISE STATED
COPYRIGHT	
This drawing and any information or descriptive matters contained therein are the copyright property of SELF SUSTAINABLE SOLUTIONS. Neither the whole nor any extract may be disclosed, loaned, copied, or used for manufacturing or tendering purposes without their written consent.	
MATERIAL	Steel ASTM A1011 CS Type B
THICK	3.038 mm
MASS	N/A
FINISH	NONE
ENGINEER	Dirk Genis
DRAWN	Dirk Genis
DATE	2/20/2022



Robert L. Pennington PE
7629 Mallow Road
Wilmington, NC 28411
Email: robert@RLPPE.com
Phone: 910-520-0278



TITLE
CHANNEL 2"x4"

FLAT PATTERN GEOMETRY IS GOVERNED BY DXF WITH THE EXPECTED TOLERANCE OF +/- 0.15mm ON ALL DXF CUTS

This print is shared on a confidential basis subject to return upon demand by SSS and nothing herein may be reproduced, used or disclosed in whole or in part without the prior written permission of Osprea.

UNLESS OTHERWISE SPECIFIED DIMENSIONS ARE IN MILLIMETERS									
GENERAL TOLERANCES LINEAR DIMENSIONS									
LINEAR	0.5 TO 3	3 TO 6	6 TO 10	10 TO 30	30 TO 120	120 TO 400	400 TO 1000	1000 TO 2000	ALL OTHER FEATURES
	±0.1	±0.1	±0.2	±0.3	±0.5	±0.8	±1.2	±2.0	DIMENSION TOLERANCES ARE GOVERNED BY DIN ISO 2768-mK

REMOVE ALL SHARP EDGES AND BURRS	THIRD ANGLE PROJECTION	DRAWING NUMBER CHANNEL J-2
SHEET 5 OF 14		SIZE: B REVISION: 1



Ø19mm
#6 0.75"

1371

30

SHARPEN STAKE.

MATERIAL; CARBON STEEL, ASTM 615

DocuSigned by:
Robert L. Pennington PE
02643993355F452
3/13/2022

Robert L. Pennington PE
7629 Mallow Road
Wilmington, NC 28411
Email: robert@RLPPE.com
Phone: 910-520-0278



ORIGINAL SCALE	UNLESS OTHERWISE STATED
COPYRIGHT	
This drawing and any information or descriptive matters contained therein are the copyright property of SELF SUSTAINABLE SOLUTIONS. Neither the whole nor any extract may be disclosed, loaned, copied, or used for manufacturing or tendering purposes without their written consent.	
MATERIAL	Generic
THICK	
MASS	0.383 kg
FINISH	NONE
ENGINEER	Dirk Genis
DRAWN	Dirk Genis
DATE	2/20/2022



TITLE
REBAR #6

FLAT PATTERN GEOMETRY IS GOVERNED BY DXF WITH THE EXPECTED TOLERANCE OF +/- 0.15mm ON ALL DXF CUTS	This print is shared on a confidential basis subject to return upon demand by SSS and nothing hereon may be reproduced, used or disclosed in whole or in part without the prior written permission of Osprea.	UNLESS OTHERWISE SPECIFIED DIMENSIONS ARE IN MILLIMETERS		REMOVE ALL SHARP EDGES AND BURRS	THIRD ANGLE PROJECTION	DRAWING NUMBER REBAR #6 X 4.5FT
		GENERAL TOLERANCES LINEAR DIMENSIONS DIMENSION TOLERANCES ARE GOVERNED BY DIN ISO 2768-mK	ALL OTHER FEATURE DIMENSION TOLERANCES ARE GOVERNED BY DIN ISO 2768-mK			
LINEAR TO 3 : ±0.1 TO 6 : ±0.2 TO 30 : ±0.3 TO 120 : ±0.5 TO 400 : ±0.8 TO 1000 : ±1.2 TO 2000 : ±2.0						SHEET 6 OF 14 SIZE: B REVISION: 1

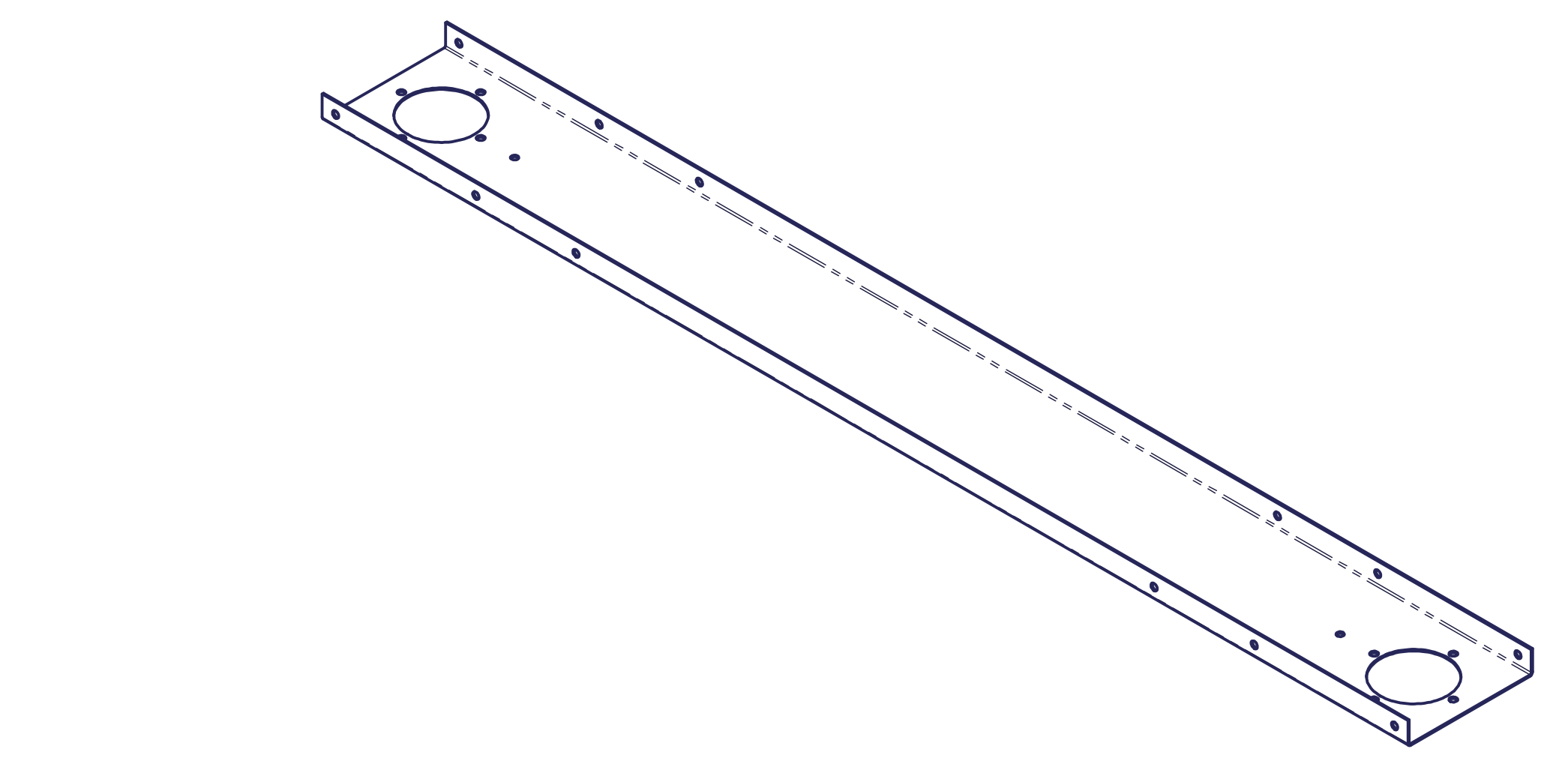
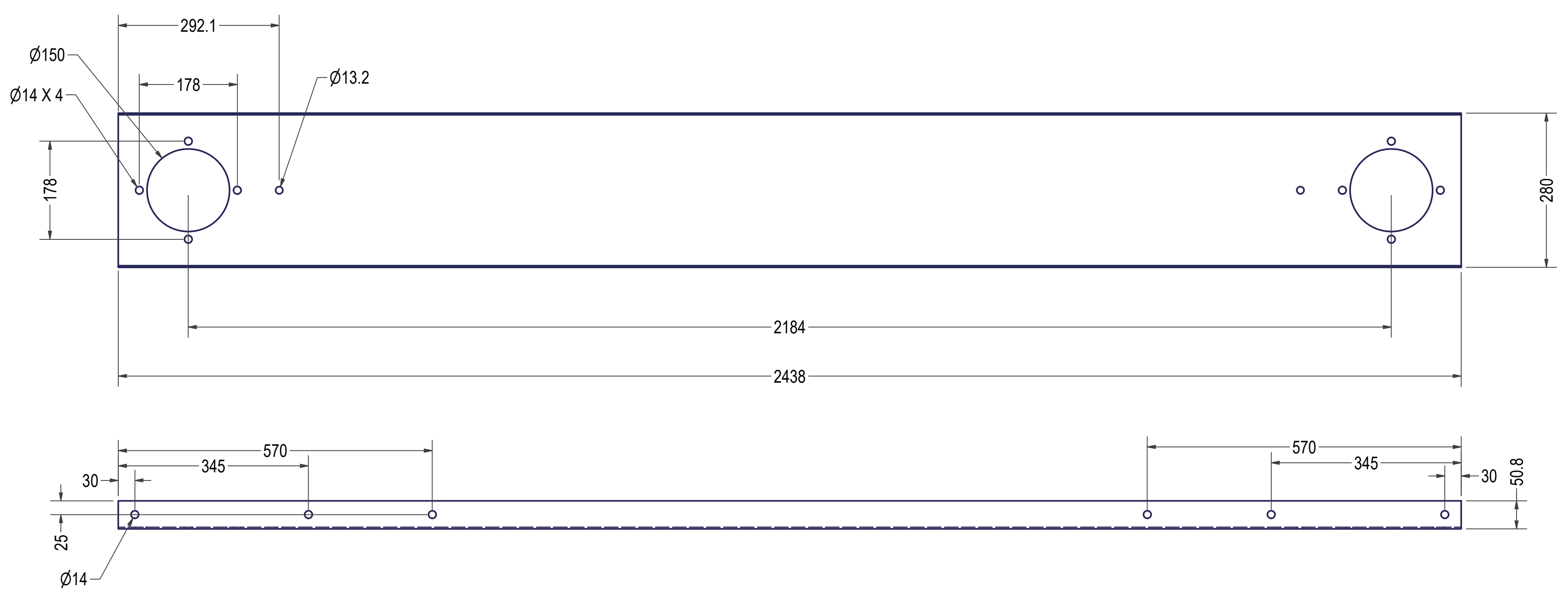

3.04mm
11ga

DXF FILE: PLATE J-1_1

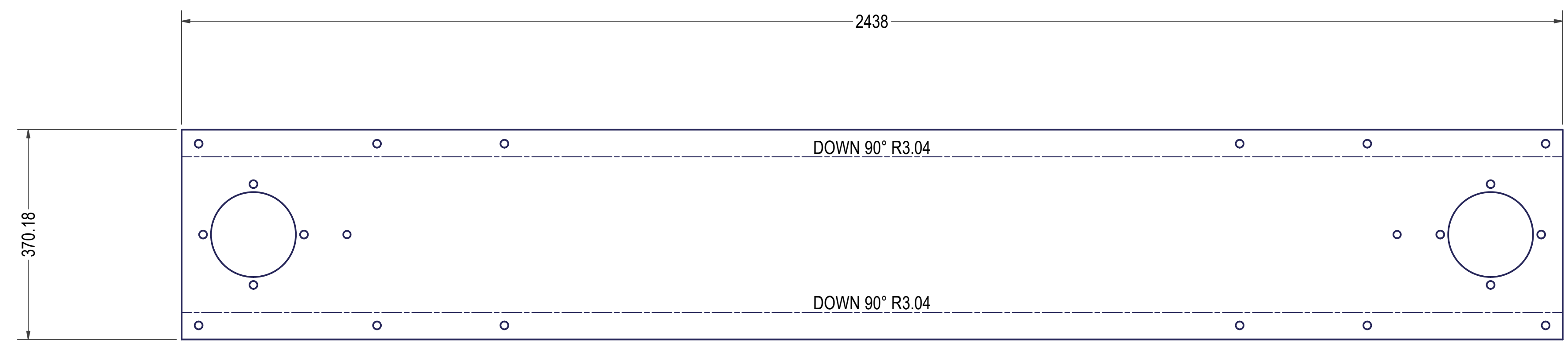

DocuSigned by:
Robert L. Pennington
0064399335DF452
3/13/2022
Robert L. Pennington PE
7629 Mallow Road
Wilmington, NC 28411
Email: robert@RLPPE.com
Phone: 910-520-0278

ORIGINAL SCALE	UNLESS OTHERWISE STATED
COPYRIGHT	
This drawing and any information or descriptive matters contained therein are the copyright property of SELF SUSTAINABLE SOLUTIONS. Neither the whole nor any extract may be disclosed, loaned, copied, or used for manufacturing or tendering purposes without their written consent.	
MATERIAL	Steel ASTM A1011 CS Type B
THICK	3.038 mm
MASS	N/A
FINISH	NONE
ENGINEER	Dirk Genis
DRAWN	Dirk Genis
DATE	2/20/2022



TITLE
PLATE JIGGING

FLAT PATTERN GEOMETRY IS GOVERNED BY DXF WITH THE EXPECTED TOLERANCE OF +/- 0.15mm ON ALL DXF CUTS	This print is shared on a confidential basis subject to return upon demand by SSS and nothing herein may be reproduced, used or disclosed in whole or in part without the prior written permission of Osprea.	UNLESS OTHERWISE SPECIFIED DIMENSIONS ARE IN MILLIMETERS		REMOVE ALL SHARP EDGES AND BURRS	THIRD ANGLE PROJECTION
		GENERAL TOLERANCES LINEAR DIMENSIONS	ALL OTHER FEATURE DIMENSION TOLERANCES ARE GOVERNED BY		
LINEAR TO : 0.5 TO : 3 TO : 6 TO : 12 TO : 25 TO : 50 TO : 100 TO : 200 TO : 400 TO : 1000 TO : 2000 TO : 4000	±0.1 ±0.1 ±0.2 ±0.3 ±0.5 ±0.8 ±1.2 ±2.0	UNLESS OTHERWISE SPECIFIED DIMENSIONS ARE IN MILLIMETERS	DIN ISO 2768-mK	SHEET 7 OF 14	SIZE B
DRAWING NUMBER PLATE J-1				REVISION 1	SHEET 7 OF 14 SIZE B REVISION 1

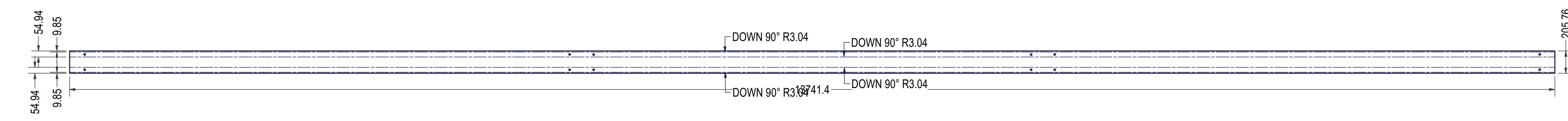
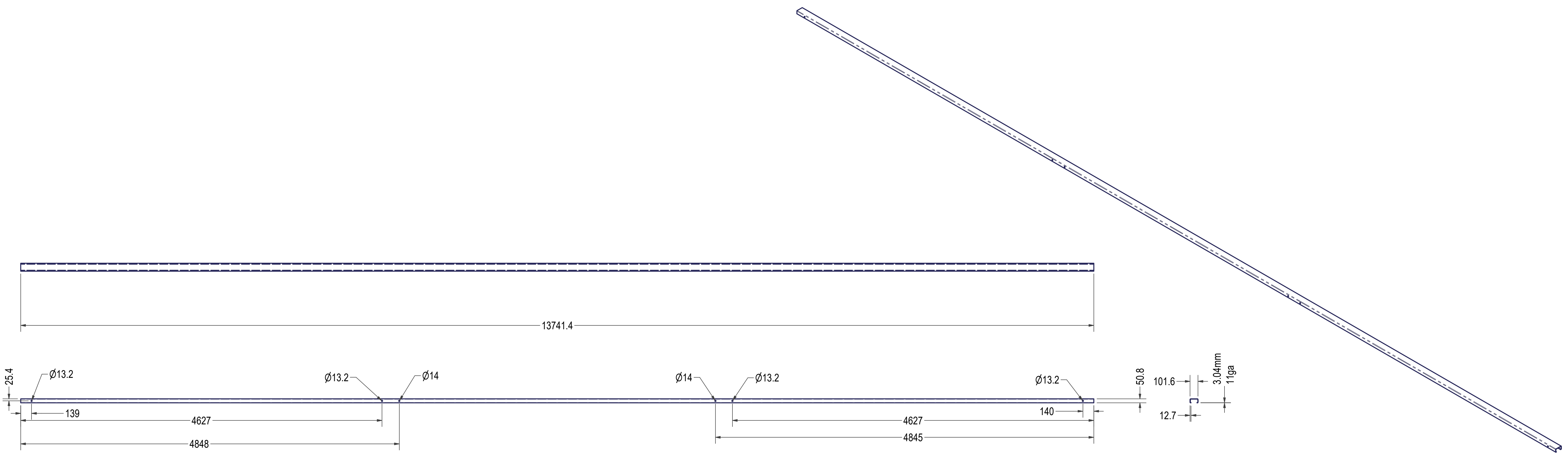

DXF FILE : CHANNEL J-1_1

DocuSigned by:
 Robert L. Pennington
 0264390335DF452
 3/13/2022

ROBERT L. PENNINGTON
 PROFESSIONAL SEAL
 ENGINEER
 NORTH CAROLINA
 25045

Robert L. Pennington PE
 7629 Mallow Road
 Wilmington, NC 28411
 Email: robert@RLPPE.com
 Phone: 910-520-0278

ORIGINAL SCALE	UNLESS OTHERWISE STATED
COPYRIGHT	
This drawing and any information or descriptive matters contained therein are the copyright property of SELF SUSTAINABLE SOLUTIONS. Neither the whole nor any extract may be disclosed, loaned, copied, or used for manufacturing or tendering purposes without their written consent.	
MATERIAL	Steel ASTM A1011 CS Type B
THICK	3.038 mm
MASS	N/A
FINISH	NONE
ENGINEER	Dirk Genis
DRAWN	Dirk Genis
DATE	2/20/2022



TITLE
 CHANNEL 2"x4"

FLAT PATTERN GEOMETRY IS GOVERNED BY DXF WITH THE EXPECTED TOLERANCE OF +/- 0.15mm ON ALL DXF CUTS		THIS PRINT IS SHARED ON A CONFIDENTIAL BASIS SUBJECT TO RETURN UPON DEMAND BY SSS AND NOTHING HEREON MAY BE REPRODUCED, USED OR DISCLOSED IN WHOLE OR IN PART WITHOUT THE PRIOR WRITTEN PERMISSION OF OSPRE.		UNLESS OTHERWISE SPECIFIED DIMENSIONS ARE IN MILLIMETERS GENERAL TOLERANCES LINEAR DIMENSIONS: ALL OTHER FEATURE DIMENSION TOLERANCES ARE GOVERNED BY DIN ISO 2768-mK		REMOVE ALL SHARP EDGES AND BURRS		THIRD ANGLE PROJECTION		DRAWING NUMBER CHANNEL J-1	
LINEAR	0.5 TO 3	3 TO 6	6 TO 30	30 TO 120	120 TO 400	400 TO 1000	1000 TO 2000	2000 TO 4000	4000 TO 6000	SHEET 8 OF 14	SIZE B
	±0.1	±0.2	±0.3	±0.5	±0.8	±1.2	±2.0				REVISION: 1

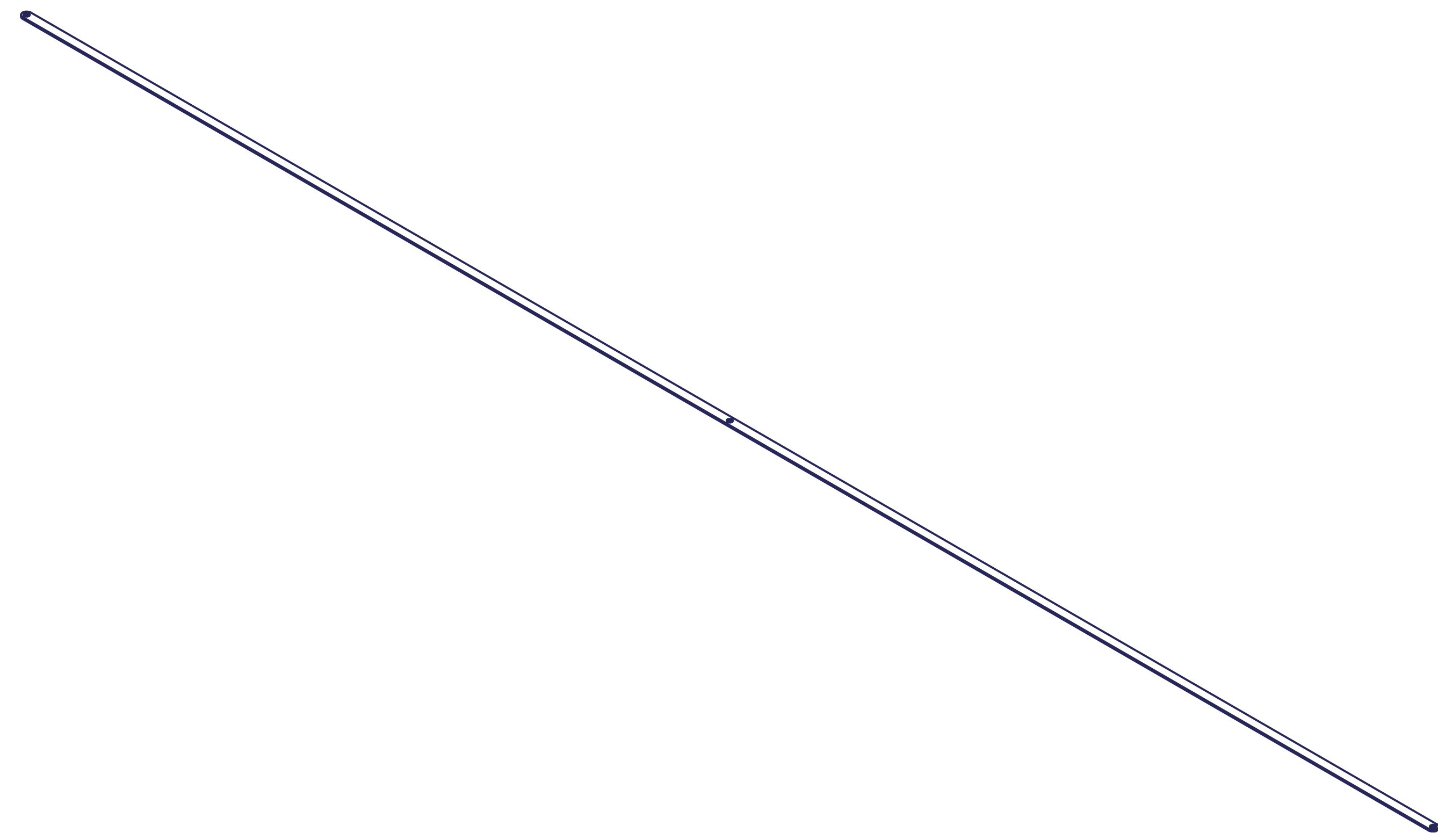

DXF FILE: STRIP CROSS BRACE_1

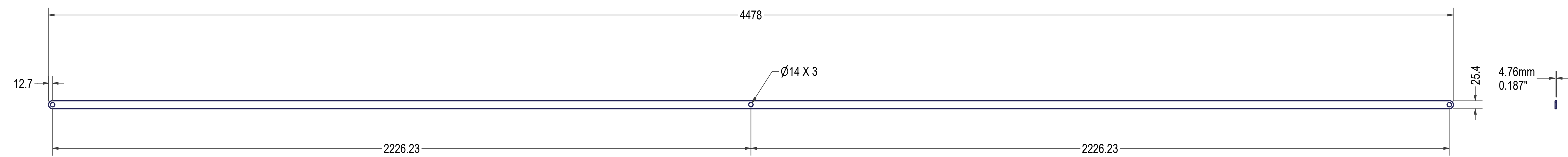

DocuSigned by:
 Robert L. Pennington
 0064599355DF452
 3/13/2022

 Robert L. Pennington PE
 7629 Mallow Road
 Wilmington, NC 28411
 Email: robert@RLPPE.com
 Phone: 910-520-0278

ORIGINAL SCALE	UNLESS OTHERWISE STATED
COPYRIGHT	
This drawing and any information or descriptive matters contained therein are the copyright property of SELF SUSTAINABLE SOLUTIONS. Neither the whole nor any extract may be disclosed, loaned, copied, or used for manufacturing or tendering purposes without their written consent.	
MATERIAL	Steel ASTM A1011 CS Type B
THICK	4.763 mm
MASS	N/A
FINISH	NONE
ENGINEER	Dirk Genis
DRAWN	Dirk Genis
DATE	2/20/2022



TITLE
PLATE CROSS BRACE

FLAT PATTERN GEOMETRY IS GOVERNED BY DXF WITH THE EXPECTED TOLERANCE OF +/- 0.15mm ON ALL DXF CUTS	This print is shared on a confidential basis subject to return upon demand by SSS and nothing hereon may be reproduced, used or disclosed in whole or in part without the prior written permission of Osprea.	UNLESS OTHERWISE SPECIFIED DIMENSIONS ARE IN MILLIMETERS		REMOVE ALL SHARP EDGES AND BURRS																								
		GENERAL TOLERANCES LINEAR DIMENSIONS ALL OTHER FEATURE DIMENSION TOLERANCES ARE GOVERNED BY UN ISO 2768-mK																										
<table border="1"> <tr> <th>LINEAR</th> <th>3</th> <th>6</th> <th>30</th> <th>120</th> <th>400</th> <th>1000</th> <th>2000</th> </tr> <tr> <td>TO</td> <td>±0.3</td> <td>±0.5</td> <td>±0.8</td> <td>±1.2</td> <td>±2.0</td> <td></td> <td></td> </tr> <tr> <td>±0.1</td> <td>±0.2</td> <td>±0.3</td> <td>±0.5</td> <td>±0.8</td> <td>±1.2</td> <td>±2.0</td> <td></td> </tr> </table>	LINEAR	3	6	30	120	400	1000	2000	TO	±0.3	±0.5	±0.8	±1.2	±2.0			±0.1	±0.2	±0.3	±0.5	±0.8	±1.2	±2.0					
LINEAR	3	6	30	120	400	1000	2000																					
TO	±0.3	±0.5	±0.8	±1.2	±2.0																							
±0.1	±0.2	±0.3	±0.5	±0.8	±1.2	±2.0																						
DRAWING NUMBER STRIP CROSS BRACE				SHEET 9 OF 14 SIZE: B REVISION: 1																								

ITEM	QTY	PART NUMBER	BOM	DESCRIPTION
1	1	PLATE J-3		PLATE JIGGING
2	1	SUPPORT ASSY-1		SUPPORT

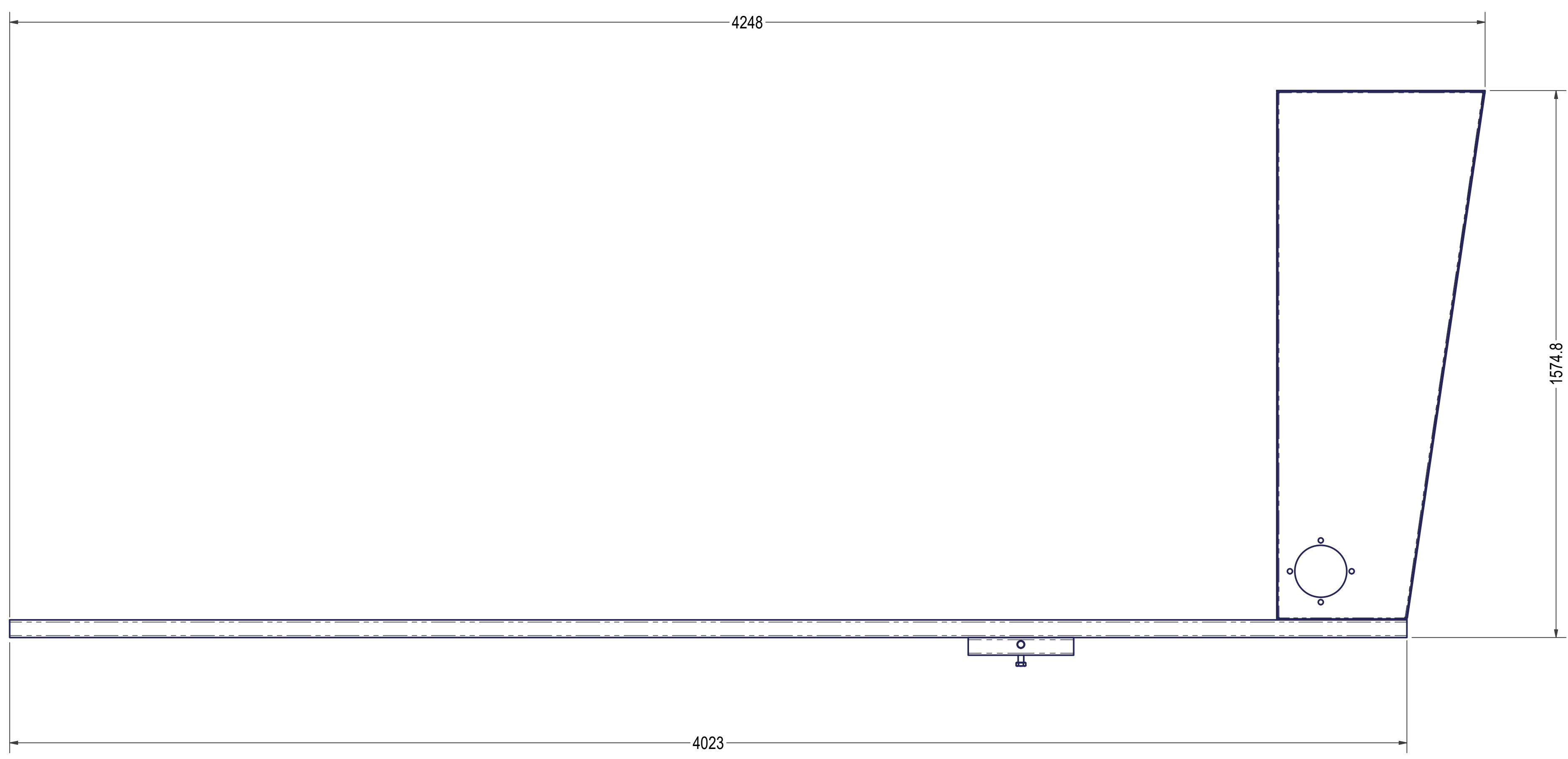
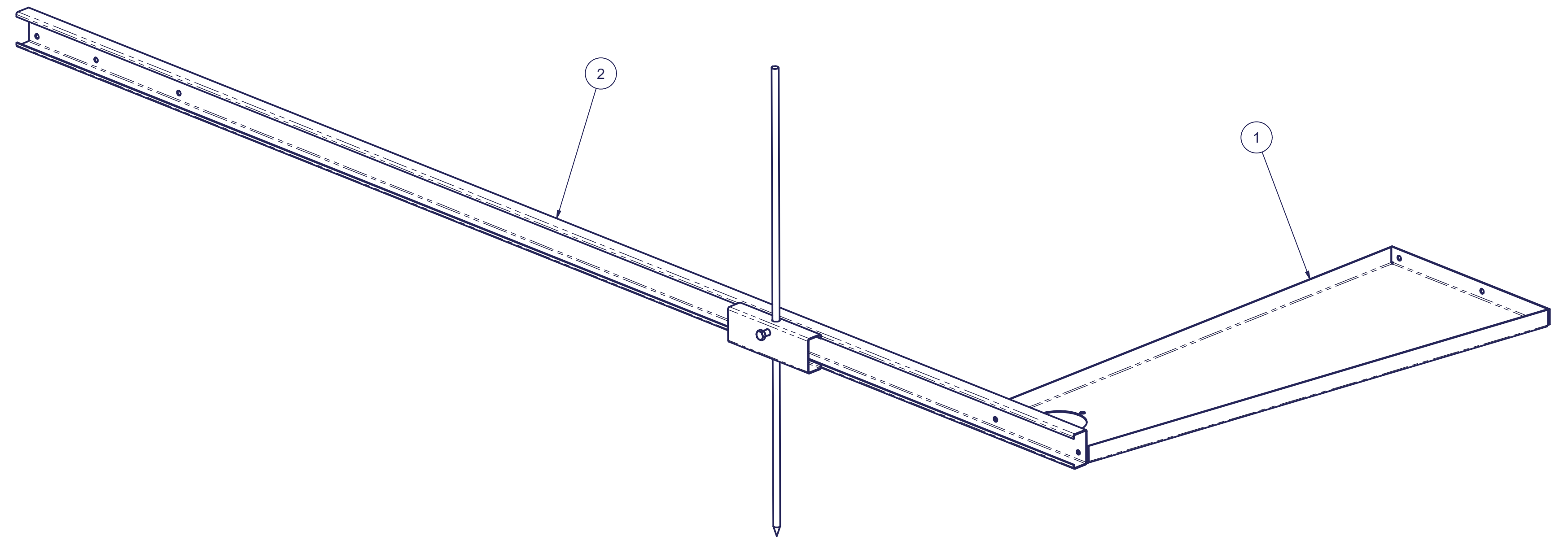

ORIGINAL SCALE	UNLESS OTHERWISE STATED
COPYRIGHT	
This drawing and any information or descriptive matters contained therein are the copyright property of SELF SUSTAINABLE SOLUTIONS. Neither the whole nor any extract may be disclosed, loaned, copied, or used for manufacturing or tendering purposes without their written consent.	
MATERIAL	
THICK	
MASS	N/A
FINISH	NONE
ENGINEER	Dirk Genis
DRAWN	Dirk Genis
DATE	2/20/2022



DocuSigned by:
Robert L. Pennington
3/13/2022

Robert L. Pennington PE
7629 Mallow Road
Wilmington, NC 28411
Email: robert@RLPPE.com
Phone: 910-520-0278



FLAT PATTERN GEOMETRY IS GOVERNED BY DXF WITH THE EXPECTED TOLERANCE OF +/- 0.15mm ON ALL DXF CUTS		THIS PRINT IS SHARED ON A CONFIDENTIAL BASIS SUBJECT TO RETURN UPON DEMAND BY SSS AND NOTHING HEREON MAY BE REPRODUCED, USED OR DISCLOSED IN WHOLE OR IN PART WITHOUT THE PRIOR WRITTEN PERMISSION OF OSPRE.		UNLESS OTHERWISE SPECIFIED DIMENSIONS ARE IN MILLIMETERS GENERAL TOLERANCES LINEAR DIMENSIONS ALL OTHER FEATURE DIMENSION TOLERANCES ARE GOVERNED BY DIN ISO 2768-mK		REMOVE ALL SHARP EDGES AND BURRS		THIRD ANGLE PROJECTION		DRAWING NUMBER: JIG FRAME ASSY.FOUND.S2 SHEET 10 OF 14 SIZE: B REVISION: 1	
LINEAR	0.5	3	8	30	120	400	1000	2000	4000		
TO	±0.1	±0.2	±0.3	±0.5	±0.8	±1.2	±2.0				

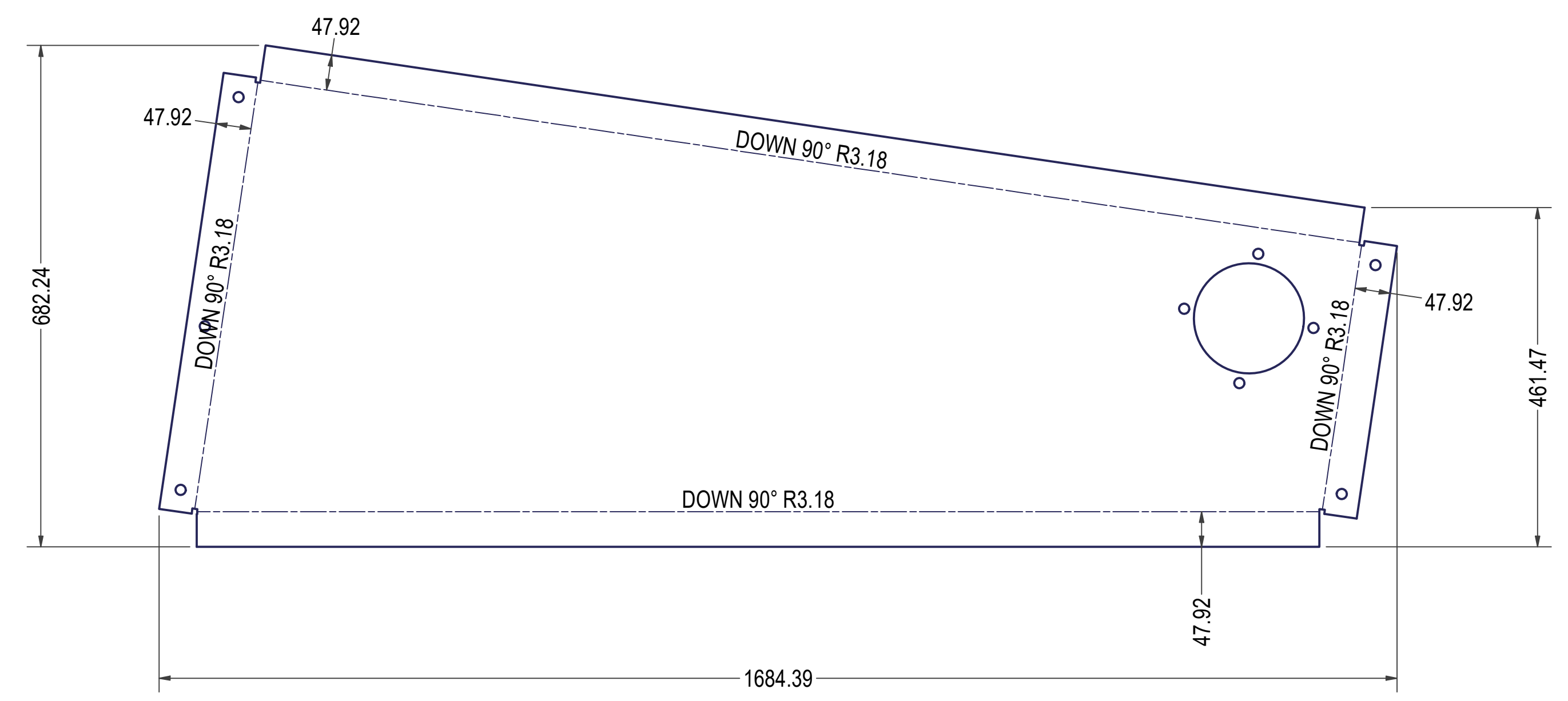
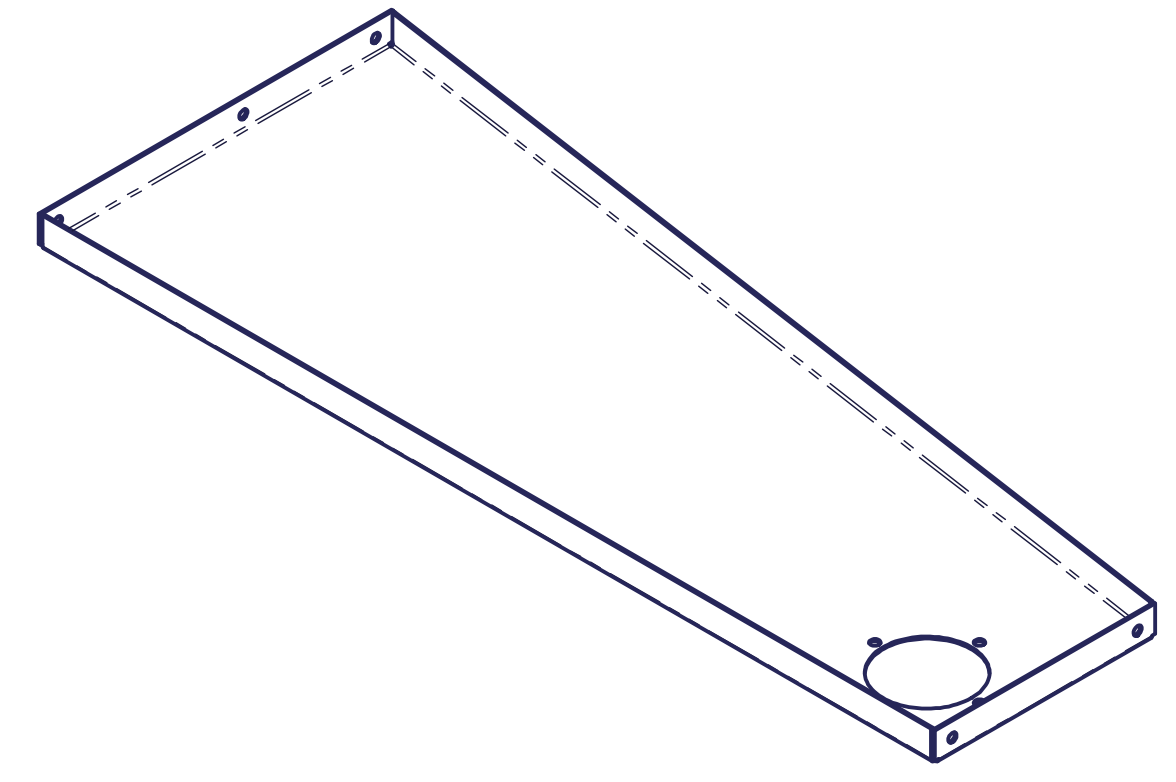
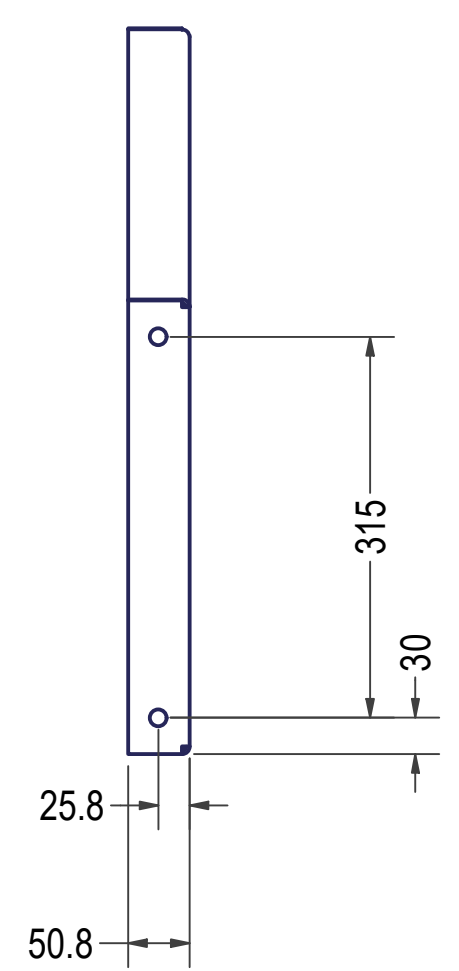
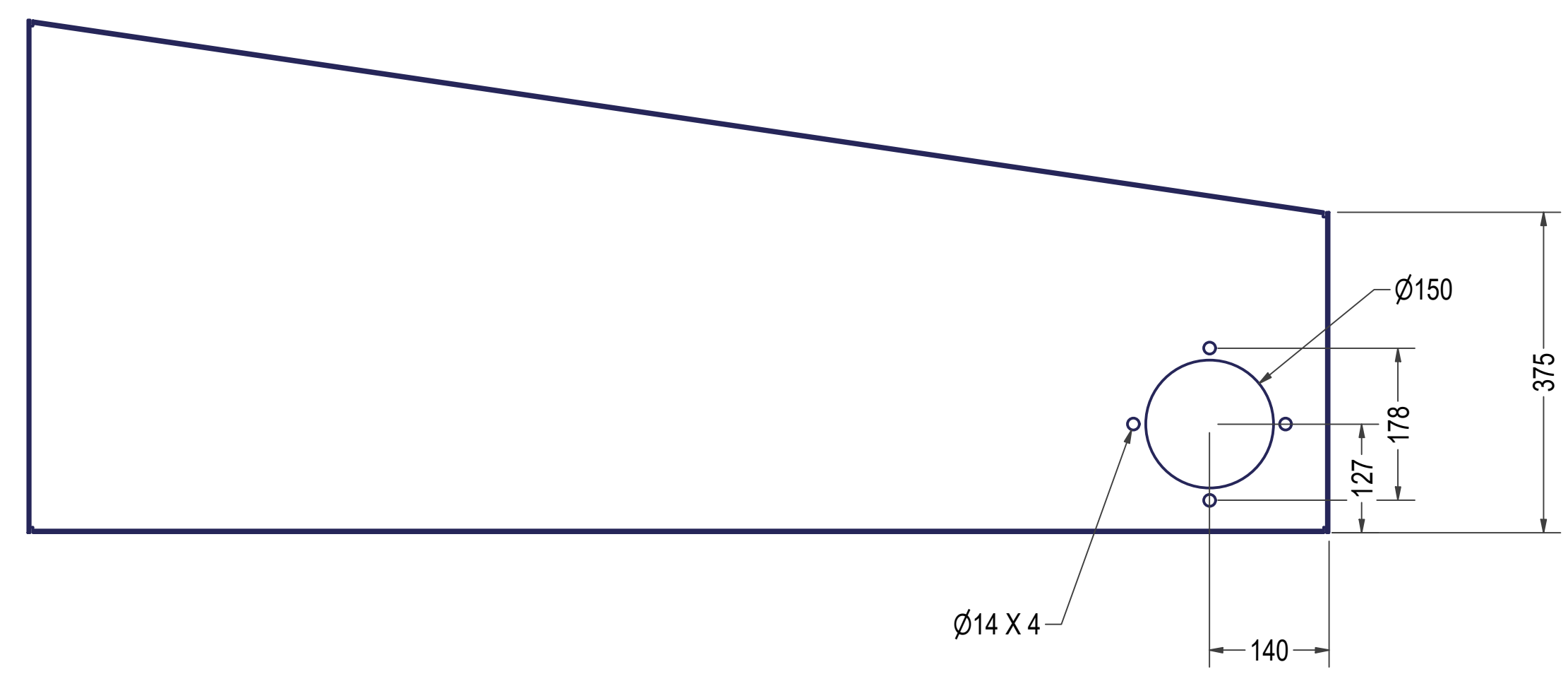
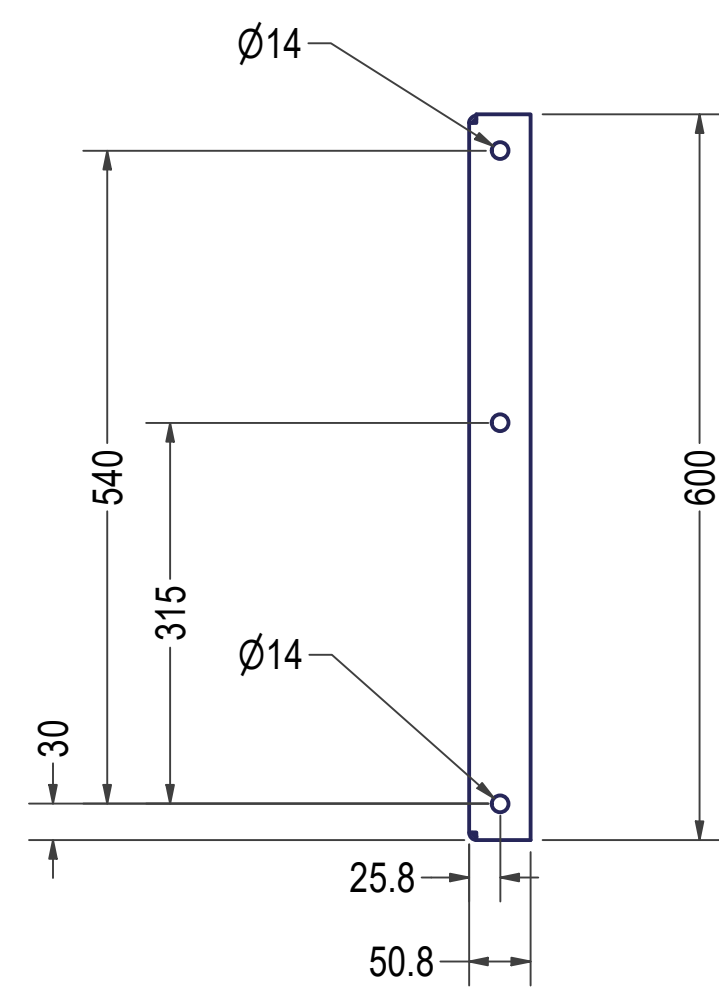

DXF FILE: PLATE J-3_1



Robert L. Pennington PE
 7629 Mallow Road
 Wilmington, NC 28411
 Email: robert@RLPPE.com
 Phone: 910-520-0278

ORIGINAL SCALE	UNLESS OTHERWISE STATED
COPYRIGHT	
This drawing and any information or descriptive matters contained therein are the copyright property of SELF SUSTAINABLE SOLUTIONS. Neither the whole nor any extract may be disclosed, loaned, copied, or used for manufacturing or tendering purposes without their written consent.	
MATERIAL	SHAFT STOCK, AISI 1018 CF
THICK	3.038 mm
MASS	N/A
FINISH	NONE
ENGINEER	Dirk Genis
DRAWN	Dirk Genis
DATE	2/20/2022



TITLE
PLATE JIGGING

FLAT PATTERN GEOMETRY IS GOVERNED BY DXF WITH THE EXPECTED TOLERANCE OF +/- 0.15mm ON ALL DXF CUTS		UNLESS OTHERWISE SPECIFIED DIMENSIONS ARE IN MILLIMETERS GENERAL TOLERANCES LINEAR DIMENSIONS ALL OTHER FEATURES DIMENSION TOLERANCES ARE GOVERNED BY DIN ISO 2768-mK		REMOVE ALL SHARP EDGES AND BURRS THIRD ANGLE PROJECTION	
DRAWING NUMBER PLATE J-3		SHEET 11 OF 14 SIZE: B REVISION: 1		TITLE PLATE JIGGING	

ITEM		QTY		PART NUMBER		BOM		DESCRIPTION	
2	1	LOCK ASSY ANCHOR STAKE	LOCK ASSEMBLY						

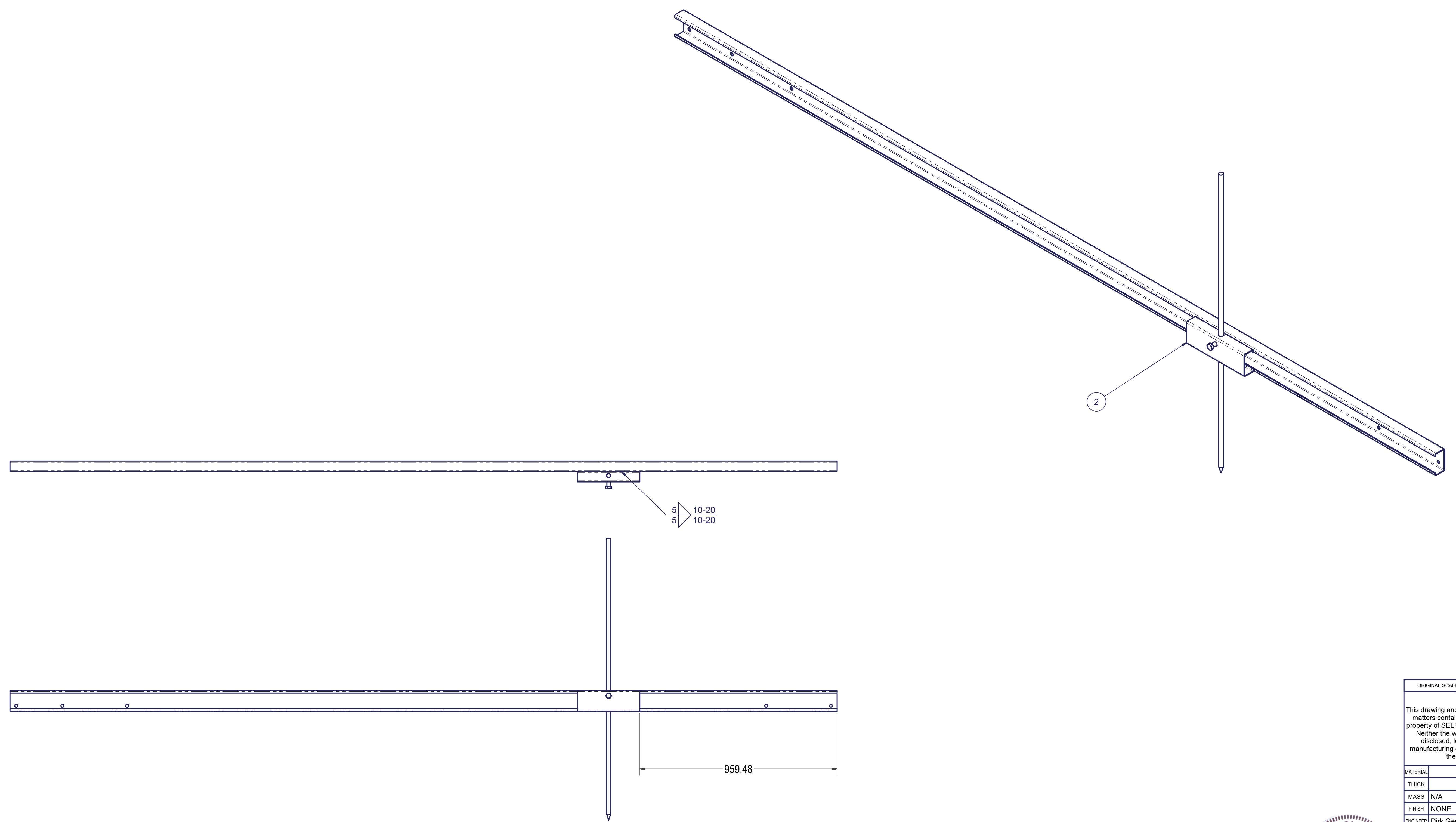

DocuSigned by:
Robert L. Pennington
 SD64399335CF452
 3/13/2022

ROBERT L. PENNINGTON
 PROFESSIONAL ENGINEER
 SEAL 25045
 NORTH CAROLINA

Robert L. Pennington PE
 7629 Mallow Road
 Wilmington, NC 28411
 Email: robert@RLPPE.com
 Phone: 910-520-0278

ORIGINAL SCALE	UNLESS OTHERWISE STATED
COPYRIGHT	
This drawing and any information or descriptive matters contained therein are the copyright property of SELF SUSTAINABLE SOLUTIONS. Neither the whole nor any extract may be disclosed, loaned, copied, or used for manufacturing or tendering purposes without their written consent.	
MATERIAL	
THICK	
MASS	N/A
FINISH	NONE
ENGINEER	Dirk Genis
DRAWN	Dirk Genis
DATE	2/20/2022



TITLE: SUPPORT

FLAT PATTERN GEOMETRY IS GOVERNED BY DXF WITH THE EXPECTED TOLERANCE OF +/- 0.15mm ON ALL DXF CUTS	This print is shared on a confidential basis subject to return upon demand by SSS and nothing herein may be reproduced, used or disclosed in whole or in part without the prior written permission of Osprea.	UNLESS OTHERWISE SPECIFIED DIMENSIONS ARE IN MILLIMETERS		REMOVE ALL SHARP EDGES AND BURRS	THIRD ANGLE PROJECTION	DRAWING NUMBER SUPPORT ASSY-1
		GENERAL TOLERANCES LINEAR DIMENSIONS ALL OTHER FEATURE DIMENSION TOLERANCES ARE GOVERNED BY DIN ISO 2768-mK	ALL OTHER FEATURE DIMENSION TOLERANCES ARE GOVERNED BY DIN ISO 2768-mK			
LINEAR TO : 0.5 TO : 3 TO : 6 TO : 30 TO : 120 TO : 400 TO : 1000 TO : 2000 TO : 4000 TO : 10000 TO : 20000	TOLERANCE ±0.1 ±0.1 ±0.1 ±0.2 ±0.3 ±0.5 ±0.8 ±1.2 ±2.0					SHEET 12 OF 14 SIZE: B REVISION: 1



ORIGINAL SCALE	UNLESS OTHERWISE STATED
COPYRIGHT	
<p>This drawing and any information or descriptive matters contained therein are the copyright property of SELF SUSTAINABLE SOLUTIONS. Neither the whole nor any extract may be disclosed, loaned, copied, or used for manufacturing or tendering purposes without their written consent.</p>	
MATERIAL	
THICK	
MASS	
FINISH	
ENGINEER	
DRAWN	Dirk Genis
DATE	2/20/2022
	
TITLE	
DRAWING NUMBER	
THIRD ANGLE PROJECTION	SHEET 13 OF 14
	SIZE: B
	REVISION: 1



Robert L. Pennington PE
 7629 Mallow Road
 Wilmington, NC 28411
 Email: robert@RLPPE.com
 Phone: 910-520-0278

DocuSigned by:
 Robert L. Pennington
 0D64399335DF452
 3/13/2022

FLAT PATTERN GEOMETRY IS GOVERNED BY DXF WITH THE EXPECTED TOLERANCE OF +/- 0.15mm ON ALL DXF CUTS

This print is shared on a confidential basis subject to return upon demand by SSS and nothing herein may be reproduced, used or disclosed in whole or in part without the prior written permission of Osprea.

UNLESS OTHERWISE SPECIFIED DIMENSIONS ARE IN MILLIMETERS									
GENERAL TOLERANCES LINEAR DIMENSIONS									
LINEAR	0.5 TO 3	3 TO 6	6 TO 12	12 TO 30	30 TO 100	100 TO 400	400 TO 1000	1000 TO 2000	ALL OTHER FEATURE DIMENSION TOLERANCES ARE GOVERNED BY
	±0.1	±0.2	±0.3	±0.5	±0.8	±1.2	±2.0		DIN ISO 2768-mK

REMOVE ALL SHARP EDGES AND BURRS

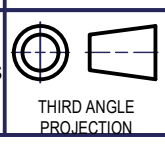

THIRD ANGLE PROJECTION

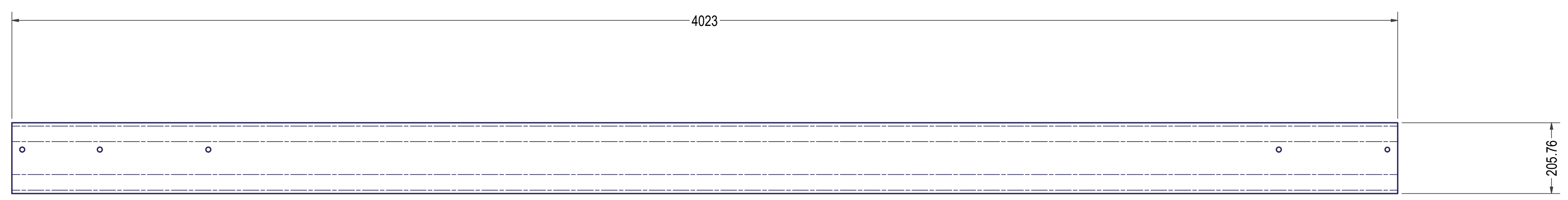
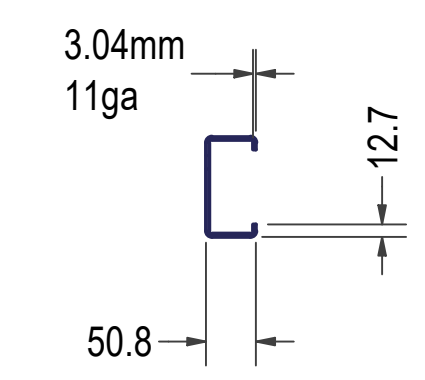
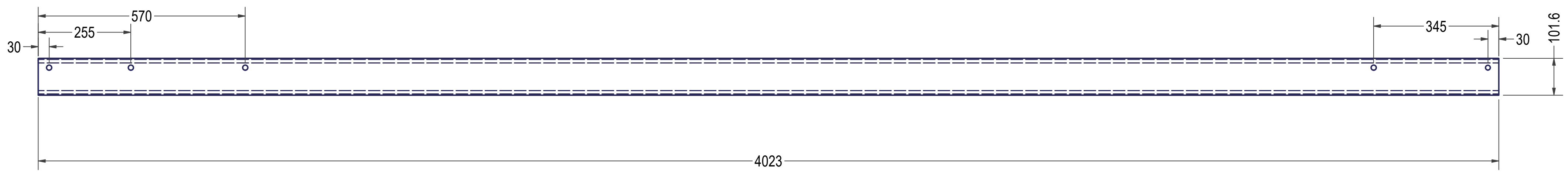
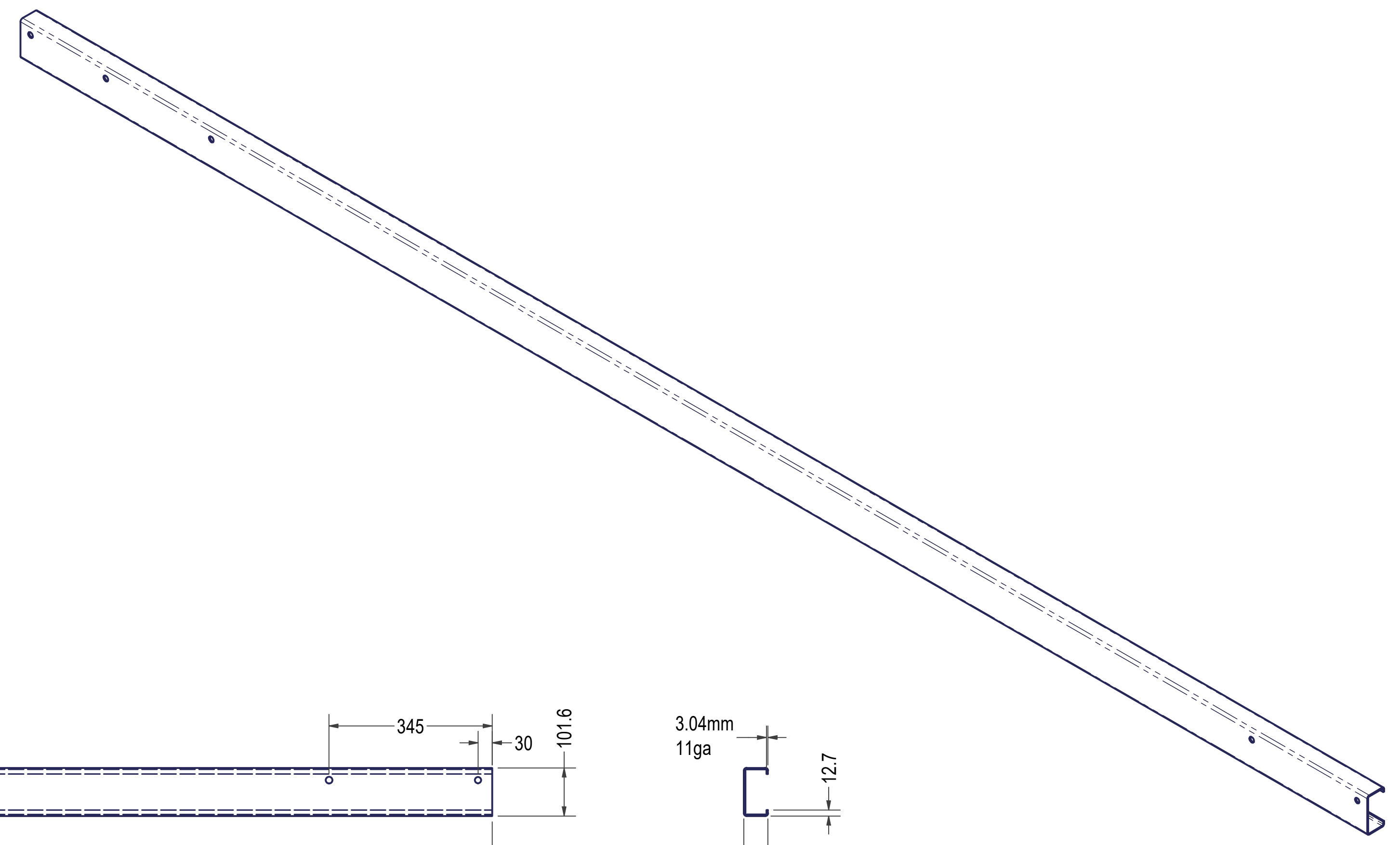

DXF FILE: CHANNEL F-5_1

DocuSigned by:
 Robert L. Pennington
 0064399335DF45
 3/13/2022

Robert L. Pennington PE
 7629 Mallow Road
 Wilmington, NC 28411
 Email: robert@RLPPE.com
 Phone: 910-520-0278



ORIGINAL SCALE	UNLESS OTHERWISE STATED
COPYRIGHT	
This drawing and any information or descriptive matters contained therein are the copyright property of SELF SUSTAINABLE SOLUTIONS. Neither the whole nor any extract may be disclosed, loaned, copied, or used for manufacturing or tendering purposes without their written consent.	
MATERIAL	Steel ASTM A1011 CS Type B
THICK	3.038 mm
MASS	N/A
FINISH	NONE
ENGINEER	Dirk Genis
DRAWN	Dirk Genis
DATE	2/20/2022



TITLE
 CHANNEL 2"x4"

FLAT PATTERN GEOMETRY IS GOVERNED BY DXF WITH THE EXPECTED TOLERANCE OF +/- 0.15mm ON ALL DXF CUTS	This print is shared on a confidential basis subject to return upon demand by SSS and nothing herein may be reproduced, used or disclosed in whole or in part without the prior written permission of Osprey.	UNLESS OTHERWISE SPECIFIED DIMENSIONS ARE IN MILLIMETERS		REMOVE ALL SHARP EDGES AND BURRS	
		GENERAL TOLERANCES LINEAR DIMENSIONS ALL OTHER FEATURE DIMENSION TOLERANCES ARE GOVERNED BY DIN ISO 2768-mK			
LINEAR TO : 0.5 TO : 3 TO : 6 TO : 30 TO : 60 TO : 120 TO : 240 TO : 480 TO : 960 TO : 1920	TOLERANCE ±0.1 ±0.2 ±0.3 ±0.5 ±0.8 ±1.2 ±2.0	THIRD ANGLE PROJECTION	SHEET 14 OF 14	SIZE B	REVISION 1

DRAWING NUMBER
CHANNEL F-5