



NOTE: ALL CHAPTERS, SECTIONS, TABLES, AND FIGURES CITED WITHOUT A PUBLICATION TITLE ARE FROM THE APPLICABLE RESIDENTIAL CODE (SEE TITLE SHEET).

**GENERAL**

- IT IS THE CONTRACTOR'S RESPONSIBILITY TO VERIFY ALL DIMENSIONS PRIOR TO CONSTRUCTION. FURTHERMORE, CONTRACTOR IS ULTIMATELY RESPONSIBLE FOR CONSTRUCTION MEANS, METHODS, AND SAFETY ON SITE. NOTIFY JDS CONSULTING, PLLC IMMEDIATELY IF DISCREPANCIES ON PLAN EXIST.
- BRACED-WALL DESIGN IS BASED ON SECTION R602.10 - WALL BRACING. PRIMARY PRESCRIPTIVE METHOD TO BE CS-WSP. SEE WALL BRACING PLANS AND DETAILS FOR ADDITIONAL INFORMATION.  
  
ALL NON-PRESCRIPTIVE SOLUTIONS ARE BASED ON GUIDELINES ESTABLISHED IN THE AMERICAN SOCIETY OF CIVIL ENGINEERS PUBLICATION ASCE 7 AND THE NATIONAL DESIGN SPECIFICATION FOR WOOD CONSTRUCTION - SPECIAL DESIGN PROVISIONS FOR WIND AND SEISMIC.
- SEISMIC DESIGN SHALL BE PER SECTION R301.2.2 - SEISMIC PROVISIONS, INCLUDING ASSOCIATED TABLES AND FIGURES, BASED ON LOCAL SEISMIC DESIGN CATEGORY.

**DESIGN LOADS**

ASSUMED SOIL BEARING-CAPACITY	2,000 PSF
<b>LIVE LOAD</b>	
ULTIMATE DESIGN WIND SPEED	115 MPH, EXPOSURE B
GROUND SNOW	15 PSF
ROOF	20 PSF

<b>RESIDENTIAL CODE TABLE R301.5</b>	<b>LIVE LOAD (PSF)</b>
DWELLING UNITS	40
SLEEPING ROOMS	30
ATTICS WITH STORAGE	20
ATTICS WITHOUT STORAGE	10
STAIRS	40
DECKS	40
EXTERIOR BALCONIES	60
PASSENGER VEHICLE GARAGES	50
FIRE ESCAPES	40
GUARDS AND HANDRAILS	200 (pounds, concentrated)

COMPONENT AND CLADDING LOADS, INCLUDING THOSE FOR DOORS AND WINDOWS, SHALL BE DERIVED FROM TABLES R301.2(2) AND R301.2(3) FOR A BUILDING WITH A MEAN ROOF HEIGHT OF 35 FEET, LOCATED IN EXPOSURE B.

**ABBREVIATIONS**

ABV	ABOVE	KS	KING STUD COLUMN
AFF	ABOVE FINISHED FLOOR	LVL	LAMINATED VENEER LUMBER
ALT	ALTERNATE	MAX	MAXIMUM
BRG	BEARING	MECH	MECHANICAL
ESMT	EASEMENT	MFR	MANUFACTURER
CANT	CANTILEVER	MIN	MINIMUM
CJ	CEILING JOIST	NTS	NOT TO SCALE
CLG	CEILING	OA	OVERALL
CMU	CONCRETE MASONRY UNIT	OC	ON CENTER
CO	CASED OPENING	PT	PRESSURE TREATED
COL	COLUMN	R	RISER
CONC	CONCRETE	REF	REFRIGERATOR
CONT	CONTINUOUS	RFG	ROOFING
D	CLOTHES DRYER	RO	ROUGH OPENING
DBL	DOUBLE	RS	ROOF SUPPORT
DIAM	DIAMETER	SC	STUD COLUMN
DJ	DOUBLE JOIST	SF	SQUARE FOOT (FEET)
DN	DOWN	SH	SHIELF / SHELVES
DP	DEEP	SHTG	SHEATHING
DR	DOUBLE RAFTER	SHW	SHOWER
DSP	DOUBLE STUD POCKET	SIM	SIMILAR
EA	EACH	SJ	SINGLE JOIST
EE	EACH END	SP	STUD POCKET
EQ	EQUAL	SPEC'D	SPECIFIED
EX	EXTERIOR	SQ	SQUARE
FAU	FORCED-AIR UNIT	T	TREAD
FDN	FOUNDATION	TEMP	TEMPERED GLASS
FF	FINISHED FLOOR	THK	THICK(NESS)
FLR	FLOOR(ING)	TJ	TRIPLE JOIST
FP	FIREPLACE	TOC	TOP OF CURB / CONCRETE
FTG	FOOTING	TR	TRIPLE RAFTER
HB	HOSE BIBB	TYP	TYPICAL
HDR	HEADER	UNO	UNLESS NOTED OTHERWISE
HGR	HANGER	W	CLOTHES WASHER
JS	JACK STUD COLUMN	WH	WATER HEATER
		WWF	WELDED WIRE FABRIC
		XJ	EXTRA JOIST

**MATERIALS**

- INTERIOR / TRIMMED FRAMING LUMBER SHALL BE #2 SPRUCE PINE FIR (SPF) WITH THE FOLLOWING DESIGN PROPERTIES (#2 SOUTHERN YELLOW PINE MAY BE SUBSTITUTED):  
  
Fb = 875 PSI    Fv = 70 PSI    E = 1.4E6 PSI
- FRAMING LUMBER EXPOSED TO WEATHER OR IN CONTACT WITH THE GROUND, CONCRETE, OR MASONRY SHALL BE PRESSURE TREATED #2 SOUTHERN YELLOW PINE (SYP) WITH THE FOLLOWING DESIGN PROPERTIES:  
  
Fb = 975 PSI    Fv = 95 PSI    E = 1.6E6 PSI
- LVL STRUCTURAL MEMBERS TO BE LAMINATED VENEER LUMBER WITH THE FOLLOWING MINIMUM DESIGN PROPERTIES:  
  
Fb = 2600 PSI    Fv = 285 PSI    E = 1.9E6 PSI
- PSL STRUCTURAL MEMBERS TO BE PARALLEL STRAND LUMBER WITH THE FOLLOWING MINIMUM DESIGN PROPERTIES:  
  
Fb = 2900 PSI    Fv = 290 PSI    E = 2.0E6 PSI
- LVL STRUCTURAL MEMBERS TO BE LAMINATED STRAND LUMBER WITH THE FOLLOWING MINIMUM DESIGN PROPERTIES:  
  
Fb = 2250 PSI    Fv = 400 PSI    E = 1.55E6 PSI
- STRUCTURAL STEEL WIDE-FLANGE BEAMS SHALL CONFORM TO ASTM A992. Fy = 60 KSI
- REBAR SHALL BE DEFORMED STEEL CONFORMING TO ASTM A615, GRADE 60.
- POURED CONCRETE COMPRESSIVE STRENGTH TO BE A MINIMUM 3,000 PSI AT 28 DAYS. MATERIALS USED TO PRODUCE CONCRETE SHALL COMPLY WITH THE APPLICABLE STANDARDS LISTED IN AMERICAN CONCRETE INSTITUTE STANDARD ACI 318 OR ASTM C1157.
- CONCRETE SUBJECT TO MODERATE OR SEVERE WEATHERING PROBABILITY PER TABLE R301.2(1) SHALL BE AIR-ENTRAINED WHEN REQUIRED BY TABLE R402.2.
- CONCRETE MASONRY UNITS (CMU) SHALL CONFORM TO AMERICAN CONCRETE INSTITUTE PUBLICATION 530: BUILDING CODE REQUIREMENTS AND SPECIFICATIONS FOR MASONRY STRUCTURES AND COMPANION COMMENTARIES AND THE MASONRY SOCIETY PUBLICATION TMS 402/602: BUILDING CODE REQUIREMENTS AND SPECIFICATIONS FOR MASONRY STRUCTURES.
- MORTAR SHALL COMPLY WITH ASTM INTERNATIONAL STANDARD C270.
- INDICATED MODEL NUMBERS FOR ALL METAL HANGERS, STRAPS, FRAMING CONNECTORS, AND HOLD-DOWNS ARE SIMPSON STRONG-TIE BRAND. EQUIVALENT USP BRAND PRODUCTS ARE ACCEPTABLE.
- REFER TO I-JOIST EQUIVALENCE CHART ON I-JOIST DETAIL SHEET FOR SUBSTITUTION OF MANUFACTURER SERIES.

**FOUNDATION**

- MINIMUM ALLOWABLE SOIL BEARING CAPACITY IS ASSUMED TO BE 2,000 PSF. IT IS THE CONTRACTOR'S RESPONSIBILITY TO VERIFY SOIL BEARING CAPACITY IF UNSATISFACTORY CONDITIONS EXIST.
- CONCRETE FOUNDATION WALLS TO BE SELECTED AND CONSTRUCTED PER SECTION R404 OR AMERICAN CONCRETE INSTITUTE STANDARD ACI 318.
- MASONRY FOUNDATION WALLS TO BE SELECTED AND CONSTRUCTED PER SECTION R404 AND/OR AMERICAN CONCRETE INSTITUTE PUBLICATION 530: BUILDING CODE REQUIREMENTS AND SPECIFICATIONS FOR MASONRY STRUCTURES AND COMPANION COMMENTARIES AND/OR THE MASONRY SOCIETY PUBLICATION TMS 402/602: BUILDING CODE REQUIREMENTS AND SPECIFICATIONS FOR MASONRY STRUCTURES.
- CONCRETE WALL HORIZONTAL REINFORCEMENT TO BE PER TABLE R404.1.2(1) OR AS NOTED OR DETAILED. CONCRETE WALL VERTICAL REINFORCEMENT TO BE PER TABLES R404.1.2(2) AND 4) OR AS NOTED OR DETAILED. ALL CONCRETE WALLS SHALL COMPLY WITH APPLICABLE PROVISIONS OF CHAPTER 6.  
  
A. TABLES ASSUME THAT WALLS HAVE PERMANENT LATERAL SUPPORT AT THE TOP AND BOTTOM.  
B. FOUNDATION DRAINS ARE ASSUMED AT ALL WALLS PER SECTION R405.
- PLAIN-MASONRY WALL DESIGN TO BE PER TABLE R404.1.1(1) OR AS NOTED OR DETAILED. MASONRY WALLS WITH VERTICAL REINFORCEMENT TO BE PER TABLES R404.1.1 (2 THROUGH 4) OR AS NOTED OR DETAILED. ALL MASONRY WALLS SHALL COMPLY WITH APPLICABLE PROVISIONS OF CHAPTER 6.  
  
A. TABLES ASSUME THAT WALLS HAVE PERMANENT LATERAL SUPPORT AT THE TOP AND BOTTOM.  
B. WALL REINFORCING SHALL BE PLACED ACCORDING TO FOOTNOTE (c) OF THE TABLES (REINFORCING IS NOT CENTERED IN WALL).  
C. FOUNDATION DRAINS ARE ASSUMED AT ALL WALLS PER SECTION R405.
- WOOD SILL PLATES TO BE ANCHORED TO THE FOUNDATION WITH 1/2" DIAMETER ANCHOR BOLTS WITH MINIMUM 7" EMBEDMENT, SPACED A MAXIMUM OF 6'-0" OC AND WITHIN 12" FROM THE ENDS OF EACH PLATE SECTION. INSTALL MINIMUM (2) ANCHOR BOLTS PER SECTION. SEE SECTION R403.1.6 FOR SPECIFIC CONDITIONS.
- THE UNSUPPORTED HEIGHT OF SOLID MASONRY PIERS SHALL NOT EXCEED TEN TIMES THEIR LEAST DIMENSION. UNFILLED, HOLLOW PIERS MAY BE USED IF THE UNSUPPORTED HEIGHT IS NOT MORE THAN FOUR TIMES THEIR LEAST DIMENSION.
- CENTERS OF PIERS TO BEAR IN THE MIDDLE THIRD OF THE FOOTINGS, AND GIRDDERS SHALL CENTER IN THE MIDDLE THIRD OF THE PIERS.
- ALL FOOTINGS TO HAVE MINIMUM 2" PROJECTION ON EACH SIDE OF FOUNDATION WALLS (SEE DETAILS).
- ALL REBAR NOTED IN CONCRETE TO HAVE AT LEAST 2" COVER FROM EDGE OF CONCRETE TO EDGE OF REBAR.
- FRAMING TO BE FLUSH WITH FOUNDATION WALLS.
- WITH CLASS 1 SOILS, VAPOR BARRIER AND CRUSHED STONE MAY BE OMITTED.

**FRAMING**

- ALL BEARING HEADERS TO BE (2) 2x6 SUPPORTED W/ MIN (1) JACK STUD AND (1) KING STUD EACH END, UNO.
- ALL NON-BEARING HEADERS TO BE (2) 2x4, UNO.
- NON-BEARING INTERIOR WALLS NOT MORE THAN 10' NOMINAL HEIGHT AND NOT SHOWN AS BRACED WALLS MAY BE FRAMED WITH 2x4 STUDS @ 24" OC.
- SOLID BLOCKING TO BE PROVIDED AT ALL POINT LOADS THROUGH FLOOR LEVELS TO THE FOUNDATION OR TO OTHER STRUCTURAL COMPONENTS.
- ALL BEAMS SPECIFIED ARE MINIMUM SIZES ONLY. LARGER MEMBERS MAY SUBSTITUTED AS NEEDED FOR EASE OF CONSTRUCTION.
- ALL EXTERIOR WALLS TO BE FULLY SHEATHED WITH 7/16" OSB.
- PORCH / PATIO COLUMNS TO BE 4x4 MINIMUM PRESSURE-TREATED LUMBER.  
A. ATTACH PORCH COLUMNS TO SLAB / FDN WALL USING ABA, ABU, ABW, OR CPT SIMPSON POST BATS TO FIT COLUMN SIZES NOTED ON PLAN -OR- ANY OTHER COLUMN CONNECTION WITH 500# UPLIFT CAPACITY.  
B. ATTACH PORCH COLUMNS TO PORCH BEAMS USING AC OR BC SIMPSON POST CAPS TO FIT COLUMN SIZES NOTED ON PLAN -OR- ANY OTHER COLUMN CONNECTION WITH 500# UPLIFT CAPACITY.  
C. TRIM OUT COLUMN(S) AND BEAM(S) PER BUILDER AND DETAILS.
- ALL ENGINEERED WOOD PRODUCTS (LVL, PSL, LSL, ETC.) SHALL BE INSTALLED WITH CONNECTIONS PER MANUFACTURER SPECIFICATIONS.
- ENGINEERED WOOD FLOOR SYSTEMS AND ROOF TRUSS SYSTEMS:  
A. SHOP DRAWINGS FOR THE SYSTEMS SHALL BE PROVIDED TO THE ENGINEER OF RECORD FOR REVIEW AND COORDINATION BEFORE CONSTRUCTION.  
B. TRUSS PROFILES SHALL BE SEALED BY THE TRUSS MANUFACTURER.  
C. INSTALLATION OF THE SYSTEMS SHALL BE PER MANUFACTURER'S INSTRUCTIONS.  
D. TRUSS LAYOUT AND PLACEMENT BY MANUFACTURER TO COINCIDE WITH THE SUPPORT LOCATIONS SHOWN IN THESE DRAWINGS.
- ALL BEAMS TO BE CONTINUOUSLY SUPPORTED LATERALLY AND SHALL BEAR FULL WIDTH ON THE SUPPORTING WALLS OR COLUMNS INDICATED, WITH A MINIMUM OF THREE STUDS, UNO.
- ALL STEEL BEAMS TO BE SUPPORTED AT EACH END WITH A MIN BEARING LENGTH OF 3' 1/2" AND FULL FLANGE WIDTH. BEAMS MUST BE ATTACHED AT EACH END WITH A MINIMUM OF FOUR 16d NAILS OR TWO 1/2" x 4" LAG SCREWS, UNO.
- STEEL FLITCH BEAMS TO BE BOLTED TOGETHER USING (2) ROWS OF 1/2" DIAMETER BOLTS (ASTM 307) WITH WASHERS PLACED UNDER THE THREADED END OF THE BOLT. BOLTS TO BE SPACED AT 24" OC (MAX) AND STAGGERED TOP AND BOTTOM OF BEAM (2" EDGE DISTANCE), WITH TWO BOLTS TO BE LOCATED AT 6" FROM EACH END OF FLITCH BEAM.
- WHEN A 4-PLY LVL BEAM IS USED, ATTACH WITH (1) 1/2" DIAMETER BOLT, 12" OC, STAGGERED TOP AND BOTTOM, 1 1/2" MIN FROM ENDS. ALTERNATE EQUIVALENT ATTACHMENT METHOD MAY BE USED, SUCH AS SDS, SDW, OR TRUSSLOK SCREWS (SEE MANUFACTURER SPECIFICATIONS).
- FOR STUD COLUMNS OF 4-OR-MORE STUDS, INSTALL SIMPSON STRONG-TIE CS16 STRAPS ACROSS STUDS @ 30" OC, 6" MAX FROM ENDS. ON INSIDE FACE OF COLUMN (EXTERIOR WALL), ON BOTH FACES OF COLUMN (INTERIOR WALL).
- FLOOR JOISTS ADJACENT AND PARALLEL TO THE EXTERIOR FOUNDATION WALL SHALL BE PROVIDED WITH FULL-DEPTH SOLID BLOCKING, NOT LESS THAN TWO (2) INCHES NOMINAL IN THICKNESS, PLACED PERPENDICULAR TO THE JOIST AT SPACING NOT MORE THAN FOUR (4) FEET. THE BLOCKING SHALL BE NAILED TO THE FLOOR SHEATHING, THE SILL PLATE, THE JOIST, AND THE EXTERIOR RIM JOIST / BOARD.
- BRACED WALL PANELS SHALL BE FASTENED TO MEET THE UPLIFT-RESISTANCE REQUIREMENTS IN CHAPTERS 6 AND 8 OF THE APPLICABLE CODE (SEE TITLE SHEET). REQUIREMENTS OF THE STRUCTURAL DRAWINGS THAT EXCEED THE CODE MINIMUM SHALL BE MET.

CONNECTION	3" x 0.131" NAIL	3" x 0.120" NAIL
JOIST TO SILL PLATE	(4) TOE NAILS	(4) TOE NAILS
SOLE PLATE TO JOIST / BLOCKING	NAILS @ 8" OC (typical) (4) PER 16" SPACE (at braced panels)	NAILS @ 8" OC (typical) (4) PER 16" SPACE (at braced panels)
STUD TO SOLE PLATE	(4) TOE NAILS	(4) TOE NAILS
TOP OR SOLE PLATE TO STUD	(3) FACE NAILS	(4) FACE NAILS
RIM JOIST OR BAND JOIST TO TOP PLATE OR SILL PLATE	TOE NAILS @ 6" OC	TOE NAILS @ 4" OC
BLOCKING BETWEEN JOISTS TO TOP PLATE OR SILL PLATE	(4) TOE NAILS	(4) TOE NAILS
DOUBLE STUD	NAILS @ 8" OC	NAILS @ 8" OC
DOUBLE TOP PLATES	NAILS @ 12" OC	NAILS @ 12" OC
DOUBLE TOP PLATES LAP (24" MIN LAP LENGTH)	(12) NAILS IN LAPPED AREA, EA SIDE OF JOINT	(12) NAILS IN LAPPED AREA, EA SIDE OF JOINT
TOP PLATE LAP AT CORNERS AND INTERSECTING WALLS	(3) FACE NAILS	(3) FACE NAILS
OPEN-WEB TRUSS BOTTOM CHORD TO TOP PLATES OR SILL PLATE (PARALLEL TO WALL)	NAILS @ 6" OC	NAILS @ 4" OC
BOTTOM CHORD OF TRUSS TO TOP PLATES OR SILL PLATE (PERPENDICULAR TO WALL)	(3) TOE NAILS	(3) TOE NAILS

SEE TABLE R602.3(1) FOR ADDITIONAL STRUCTURAL-MEMBER FASTENING REQUIREMENTS.  
DETAILS AND NOTES ON DRAWINGS GOVERN.

FRAMING MEMBER SIZE	MAX HEIGHT (PLATE TO PLATE)	115 MPH ULTIMATE DESIGN WIND SPEED
2x4 @ 16" OC	10'-0"	
2x4 @ 12" OC	12'-0"	
2x6 @ 16" OC	15'-0"	
2x6 @ 12" OC	17'-9"	
2x8 @ 16" OC	19'-0"	
2x8 @ 12" OC	22'-0"	
(2) 2x4 @ 16" OC	14'-6"	
(2) 2x4 @ 12" OC	17'-0"	
(2) 2x6 @ 16" OC	21'-6"	
(2) 2x6 @ 12" OC	25'-0"	
(2) 2x8 @ 16" OC	27'-0"	
(2) 2x8 @ 12" OC	31'-0"	

- ALL HEIGHTS ARE MEASURED SUBFLOOR TO TOP OF WALL PLATE.
- WHEN SPLIT-FRAMED WALLS ARE USED FOR HEIGHTS OVER 12', THE CONTRACTOR SHALL ADD 6" MINIMUM OF CS16 COIL STRAPPING (FULLY NAILED), CENTERED OVER THE WALL BREAK.
- FINGER-JOINTED MEMBERS MAY BE USED FOR CONTINUOUS HEIGHTS WHERE TRADITIONALLY MILLED LUMBER LENGTHS ARE LIMITED.
- FOR GREATER WIND SPEED, SEE ENGINEERED SOLUTION FOR CONDITION IN DRAWINGS.

**ROOF SYSTEMS**

**TRUSSED ROOF - STRUCTURAL NOTES**

- PROVIDE CONTINUOUS BLOCKING THROUGH STRUCTURE FOR ALL POINT LOADS.
- DENOTES OVER-FRAMED AREA
- MINIMUM 7/16" OSB ROOF SHEATHING
- TRUSS LAYOUT AND PLACEMENT BY MANUFACTURER TO COINCIDE WITH THE SUPPORT LOCATIONS SHOWN. TRUSS PROFILES SHALL BE SEALED BY THE TRUSS MANUFACTURER. TRUSS PLANS TO BE COORDINATED WITH THE SEALED STRUCTURAL DRAWINGS. INSTALLATION SHALL BE IN ACCORDANCE WITH THE MANUFACTURER'S INSTRUCTIONS.
- MANUFACTURER TO PROVIDE REQUIRED UPLIFT CONNECTION.
- PROVIDE H2.5A (MINIMUM) OR EQUIVALENT AT EACH TRUSS-TO-TOP PLATE CONNECTION AT OVER-FRAMED AREAS, UNLESS NOTED OTHERWISE.
- UPLIFT CONNECTION TO BE CARRIED THROUGH TO FLOOR SYSTEM.

**STICK-FRAMED ROOF - STRUCTURAL NOTES**

- PROVIDE 2x4 COLLAR TIES AT 48" OC AT UPPER THIRD OF RAFTERS, UNLESS NOTED OTHERWISE.
- FUR RIDGES FOR FULL RAFTER CONTACT.
- PROVIDE CONTINUOUS BLOCKING THROUGH STRUCTURE FOR ALL POINT LOADS.
- DENOTES OVER-FRAMED AREA
- MINIMUM 7/16" OSB ROOF SHEATHING
- PROVIDE 2x4 RAFTER TIES AT 16" OC AT 45° BETWEEN RAFTERS AND CEILING JOISTS. USE (4) 16d NAILS AT EACH CONNECTION. RAFTER TIES MAY BE SPACED AT 48" OC AT LOCATIONS WHERE NO KNEE WALLS ARE INSTALLED.
- PROVIDE H2.5A (MINIMUM) OR EQUIVALENT AT EACH RAFTER-TO-TOP PLATE CONNECTION AT OVER-FRAMED AREAS, UNLESS NOTED OTHERWISE.
- UPLIFT CONNECTION TO BE CARRIED THROUGH TO FLOOR SYSTEM.

SPAN	STEEL ANGLE SIZE	END BEARING LENGTH
UP TO 42"	L3-1/2"x3-1/2"x1/4"	8" (MIN. @ EACH END)
UP TO 72"	L6"x4"x5/16" (LLV)	8" (MIN. @ EACH END)
OVER 72"	L6"x4"x5/16" (LLV) ATTACH LINTEL w/ 1/2" THRU BOLT @ 12" OC, 3" FROM EACH END	

\* FOR QUEEN BRICK: LINTELS AT THIS CONDITION MAY BE 5"x3-1/2"x5/16"

NOTE: BRICK LINTELS AT SLOPED AREAS TO BE 4"x3-1/2"x1/4" STEEL ANGLE WITH 16D NAILS IN 3/16" HOLES IN 4" ANGLE LEG AT 12" OC TO TRIPLE RAFTER. WHEN THE SLOPE EXCEEDS 4:12 A MINIMUM OF 3"x3"x1/4" PLATES SHALL BE WELDED AT 24" OC ALONG THE STEEL ANGLE.

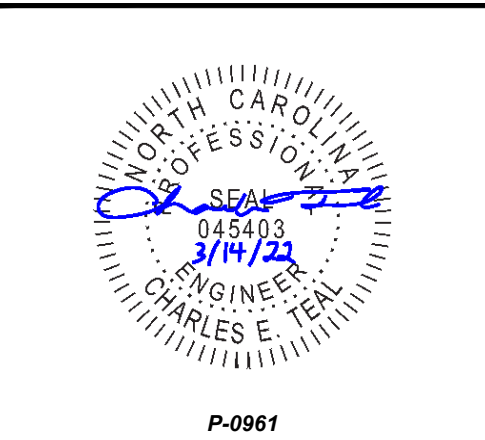

**JDS Consulting**  
ENGINEERING • DESIGN • ENERGY

JDS Consulting, PLLC, 8600 TD JERRY CT, BALLEGH, NC 27617-9040-005  
INFO@JDSCONSULTING.NET WWW.JDSCONSULTING.NET

JDS Consulting, PLLC IS NOT LIABLE FOR CHANGES MADE TO PLANS DUE TO CONSTRUCTION METHODS OR ANY CHANGES TO PLANS MADE IN THE FIELD. THE CONTRACTOR SHALL BE RESPONSIBLE FOR VERIFYING ALL DIMENSIONS, THE LOT NUMBER, PROPERTY OR AS-A MASTER PLAN, AS SPECIFIED ON TITLE SHEET. DIMENSIONS SHALL GOVERN OVER SCALE, AND CODE SHALL GOVERN OVER DIMENSIONS ON DRAWINGS.

CLIENT: TRIANGLE BUILDING & PROPERTIES  
PROJECT: CEDAR CREEK  
LOCATION: NORTH CAROLINA

SCALE: 1/4" = 1'-0" FOR 24x36 PAPER, NOT TO SCALE FOR 11x17 PAPER, OR AS NOTED

PROJECT NO.: 22900088

DATE: 03/14/2022 DRAWN BY: CAR

GENERAL NOTES

**GN1.0**

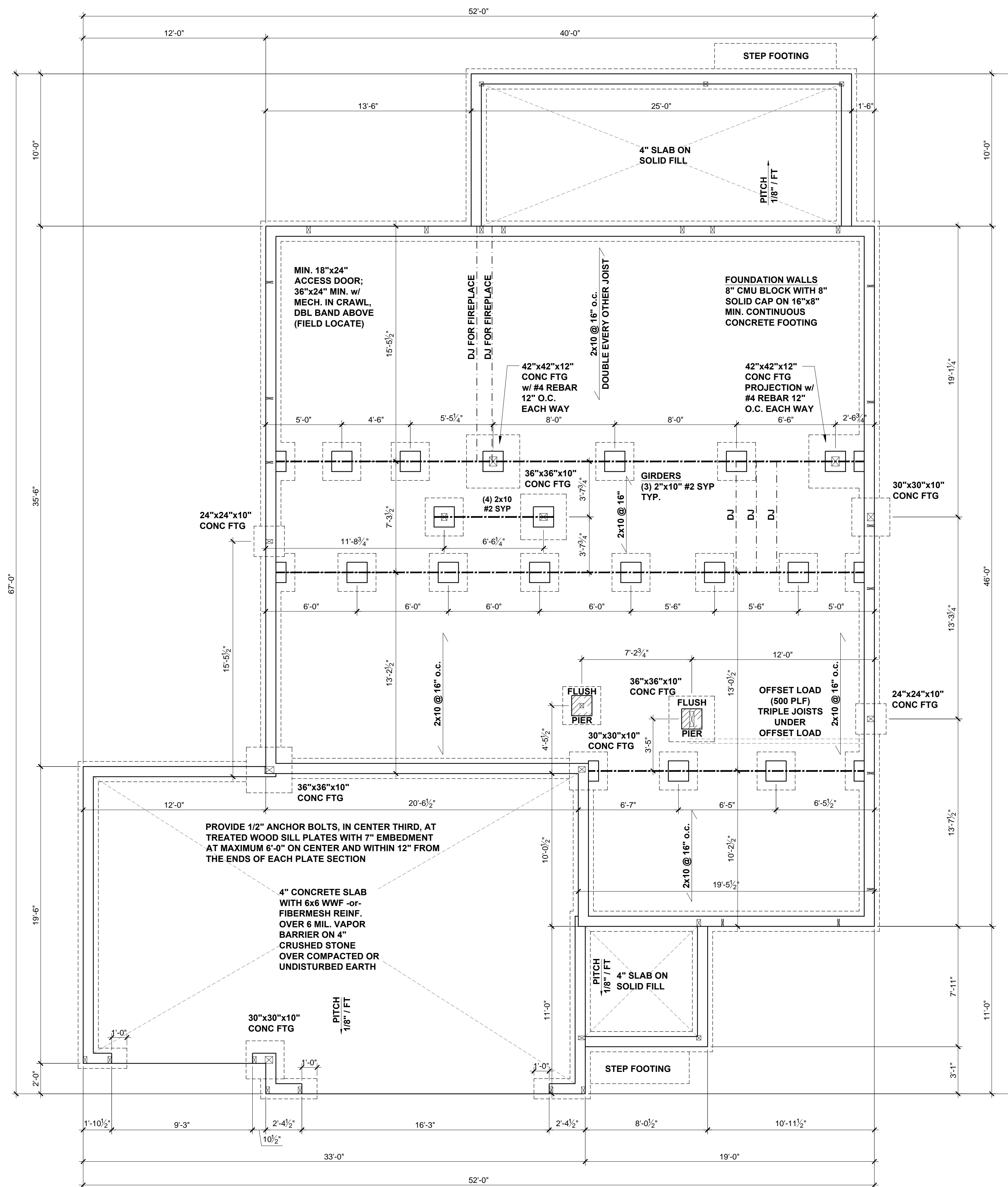

**CRAWL SPACE FOUNDATION PLAN**  
SCALE: 1/4"=1'-0"

**BEAM & POINT LOAD LEGEND**

	INTERIOR LOAD BEARING WALL
	ROOF RAFTER / TRUSS SUPPORT
	DOUBLE RAFTER / DOUBLE JOIST
	STRUCTURAL BEAM / GIRDER
	WINDOW / DOOR HEADER
	POINT LOAD TRANSFER
	POINT LOAD FROM ABOVE BEARING ON BEAM / GIRDER

**CRAWL SPACE VENTILATION**

THE MINIMUM NET AREA OF VENTILATION OPENINGS SHALL NOT BE LESS THAN 1 SQUARE FOOT FOR EACH 150 SQUARE FEET OF UNDERFLOOR SPACE AREA, AND ONE SUCH OPENING SHALL BE WITHIN 3 FEET OF EACH CORNER OF THE BUILDING.

EXCEPTION: THE TOTAL AREA OF VENTILATION MAY BE REDUCED TO 1/1500 OF THE UNDERFLOOR AREA WHERE THE GROUND SURFACE IS TREATED WITH AN APPROVED VAPOR RETARDER MATERIAL AND THE REQUIRED OPENINGS ARE PLACED SO AS TO PROVIDE CROSS-VENTILATION.

1633	SQUARE FEET OF TOTAL CRAWL SPACE / 150 =
10.8	SQUARE FEET OF NET-FREE VENTILATION REQUIRED

**FOUNDATION STRUCTURAL NOTES:**

1. CONCRETE BLOCK PIER SIZE SHALL BE:

SIZE	HOLLOW MASONRY	SOLID MASONRY
8x16	UP TO 32" HIGH	UP TO 5'-0" HIGH
12x16	UP TO 48" HIGH	UP TO 9'-0" HIGH
16x16	UP TO 64" HIGH	UP TO 12'-0" HIGH
24x24	UP TO 96" HIGH	

WITH 30" x 30" x 10" CONCRETE FOOTING, UNO.

8"x16" PIERS AT FOUNDATION WALL SUPPORTING DROPPED GIRDER TO HAVE A 30"x10"x8" FOOTING PROJECTION FROM THE MAIN WALL FOOTING.

EXTRA JOISTS UNDER ALL NON LOAD BEARING WALLS THAT RUN AT LEAST 30% OF THE JOIST SPAN.

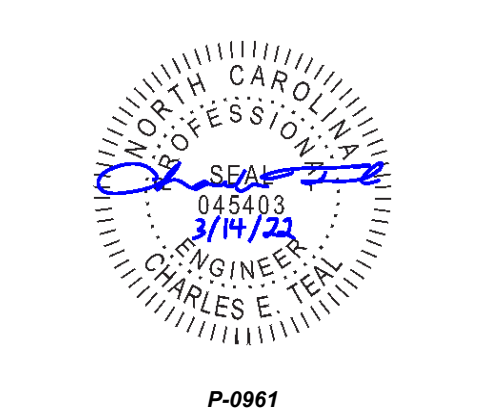

**JDS Consulting**  
ENGINEERING • DESIGN • ENERGY

JDS Consulting LLC, 8600 W. JERSEY CT. RALEIGH, NC 27617 919.480.1005  
INFO@JDSCONSULTING.NET WWW.JDSCONSULTING.NET

JDS Consulting PLLC IS NOT LIABLE FOR CHANGES MADE TO PLANS DUE TO CONSTRUCTION METHODS OR ANY CHANGES TO PLANS MADE IN THE FIELD. THE CONTRACTOR SHALL BE RESPONSIBLE FOR VERIFYING ALL DIMENSIONS, THE LOT NUMBER, PROPERTY OR ASA MASTER PLAN SPECIFICATION TITLE SHEET, DIMENSIONS, SHALL GOVERN OVER SCALE, AND CODE SHALL GOVERN OVER DIMENSIONS ON DRAWINGS.

CLIENT: **TRIANGLE BUILDING & PROPERTIES**

PROJECT: **CEDAR CREEK**

LOCATION: **NORTH CAROLINA**

SCALE: 1/4" = 1'-0" FOR 24x36 PAPER, NOT TO SCALE FOR 11x17 PAPER, OR AS NOTED

PROJECT NO.: **22900088**

DATE: **03/14/2022** DRAWN BY: **CAR**

CRAWL SPACE FOUNDATION PLAN

**F1.0**

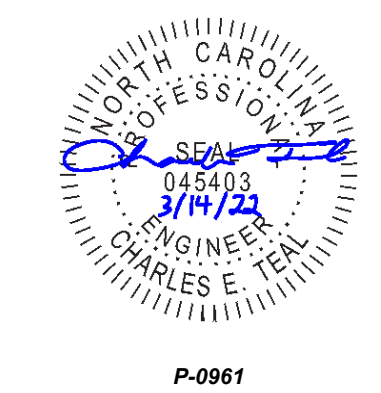

P-0961

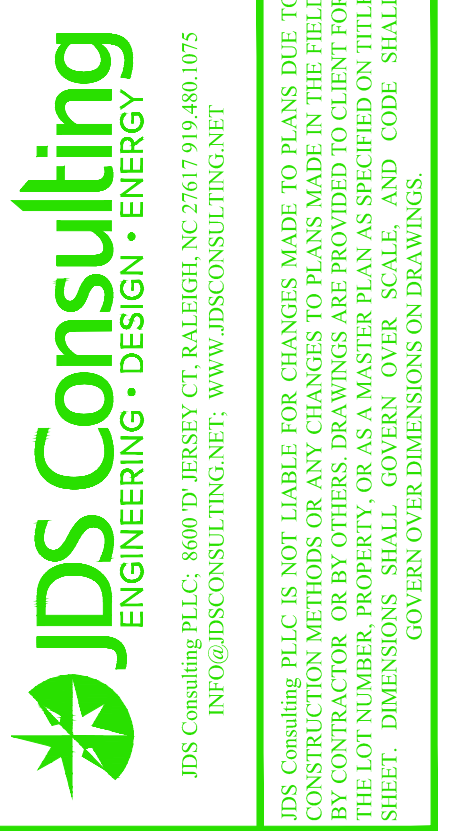

JDS Consulting is NOT LIABLE FOR CHANGES MADE TO PLANS DUE TO CONSTRUCTION METHODS OR ANY CHANGES TO PLANS MADE IN THE FIELD. THE LOT NUMBER, PROPERTY OR ASA MASTER PLAN AS SPECIFIED ON TITLE SHEET, DIMENSIONS, SHALL GOVERN OVER SCALE, AND CODE SHALL GOVERN OVER DIMENSIONS ON DRAWINGS.

CLIENT: **TRIANGLE BUILDING & PROPERTIES**  
 PROJECT: **CEDAR CREEK**  
 LOCATION: **NORTH CAROLINA**

PROJECT NO.: **22900088**  
 DATE: **03/14/2022** DRAWN BY: **CAR**

STANDARD FIRST FLOOR CEILING FRAMING PLAN

**S1.0**

SCALE: 1/4" = 1'-0" FOR 24x36 PAPER, NOT TO SCALE FOR 11x17 PAPER, OR AS NOTED

**BEAM & POINT LOAD LEGEND**

- INTERIOR LOAD BEARING WALL
- ROOF RAFTER / TRUSS SUPPORT
- - - DOUBLE RAFTER / DOUBLE JOIST
- STRUCTURAL BEAM / GIRDER
- WINDOW / DOOR HEADER
- ⊠ POINT LOAD TRANSFER
- POINT LOAD FROM ABOVE BEARING ON BEAM / GIRDER

- STRUCTURAL FRAMING NOTES - (SEE GENERAL NOTES SHEET FOR ADDITIONAL REQUIREMENTS.)**
- ALL FRAMING TO BE #2 SPF MINIMUM.
  - ALL BEARING HEADERS TO BE (2) 2x6 SUPPORTED w/ MIN (1) JACK AND (1) KING EACH END, UNO.
  - EXTERIOR WALL OPENINGS OVER 3' TO HAVE MULTIPLE KING STUDS AS NOTED ON PLAN.
  - ALL NON-BEARING HEADERS TO BE (2) 2x4 (1) J / (1) K, UNO.
  - PROVIDE CONTINUOUS BLOCKING THROUGH STRUCTURE FOR ALL POINT LOADS.
  - ALL HANGERS AND CONNECTORS SPECIFIED ARE TO BE SIMPSON STRONG-TIE OR EQUIVALENT.
  - ALL BEAMS SPECIFIED ARE MINIMUM SIZES ONLY. LARGER MEMBERS MAY SUBSTITUTED AS NEEDED FOR EASE OF CONSTRUCTION. MINIMUM BEAM SUPPORT IS (1) 2x4 STUD.
  - ALL EXTERIOR WALLS TO BE FULLY SHEATHED WITH 7/16" OSB.
  - FRONT PORCH COLUMNS TO BE MIN 4x4 PT ATTACHED AT TOP AND BOTTOM USING SIMPSON (OR EQUIV) COLUMN BASE OR SST A24 BRACKETS. TRIM OUT PER BUILDER.
  - PORCH COLUMNS TO BE MIN 4x4 PT ATTACHED AT BOTTOM USING SIMPSON (OR EQUIV) ABA44 AND AT TOP USING CS 16 STRAPPING (12" MIN) TO PORCH HEADER / BAND.
  - WHEN A 4-PLY LVL IS USED, ATTACH WITH (1) 1/2" Ø BOLT 12" OC STAGGERED, TOP AND BOTTOM, 1-1/2" MIN FROM ENDS. ALTERNATE ATTACHMENT EQUIVALENT METHOD MAY BE USED, SUCH AS SDW OR TRUSSLOK SCREWS (SEE MANUFACTURER'S SPECIFICATIONS).
  - FOR STUD COLUMNS OF 4 OR MORE, INSTALL SST CS16 STRAPS @ 30" OC, 6" MAX FROM PLATES, ON INSIDE FACE OF COLUMN (EXTERIOR WALL), ON BOTH FACES OF COLUMN (INTERIOR WALL).

ALL FLUSH BEAMS TO BE DIRECTLY SUPPORTED BY (2) 2x STUDS UNLESS OTHERWISE NOTED. STUD COLUMNS TO BE SUPPORTED BY SOLID BLOCKING TO FOUNDATION OR TO BEARING COLUMN BELOW.

FLOOR FRAMING TO BE 11 7/8" DEEP TJI 210 SERIES OR EQUAL, 19.2" OC MAXIMUM SPACING UNLESS OTHERWISE NOTED ON THE PLANS

\*\*REFER TO I-JOIST EQUIVALENCE CHART ON I-JOIST DETAIL SHEET FOR SUBSTITUTION OF MANUFACTURER SERIES

EXTRA JOISTS UNDER ALL NON LOAD BEARING WALLS THAT RUN AT LEAST 30% OF THE JOIST SPAN.

ALL EXTERIOR WALLS TO BE 2X6 UNLESS NOTED OTHERWISE

**LCE4 BRACING CON.**

- NTS
- ▶ LCE4 CLIP TO HEADER JACK CONNECTION AND A35 CLIP AT THE JACK BOTTOM PLATE CONNECTION
  - ◆ CS16 STRAP FROM STUD, CROSS HEADER, TO WALL TOP PLATE, 36" LONG MIN.
  - ▶ SIMPSON HTT4 HOLD DOWN FOR ATTACHMENT TO CONCRETE OR MST18 STRAP FOR WOOD CONNECTIONS.

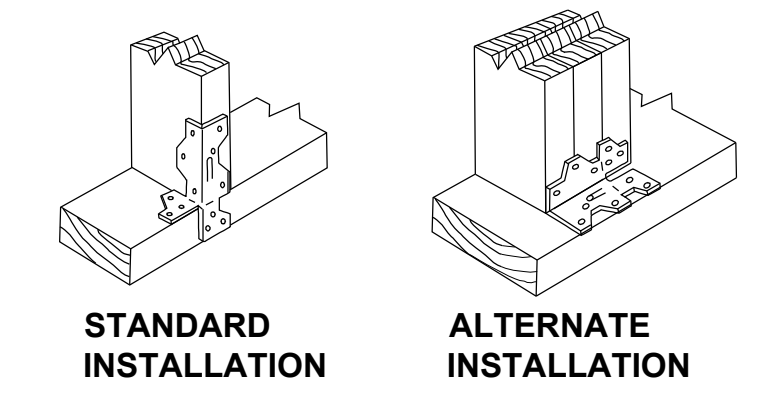

**LOWER BRACING CON.**

NTS A35 CLIP WITH SD9112 SCREWS

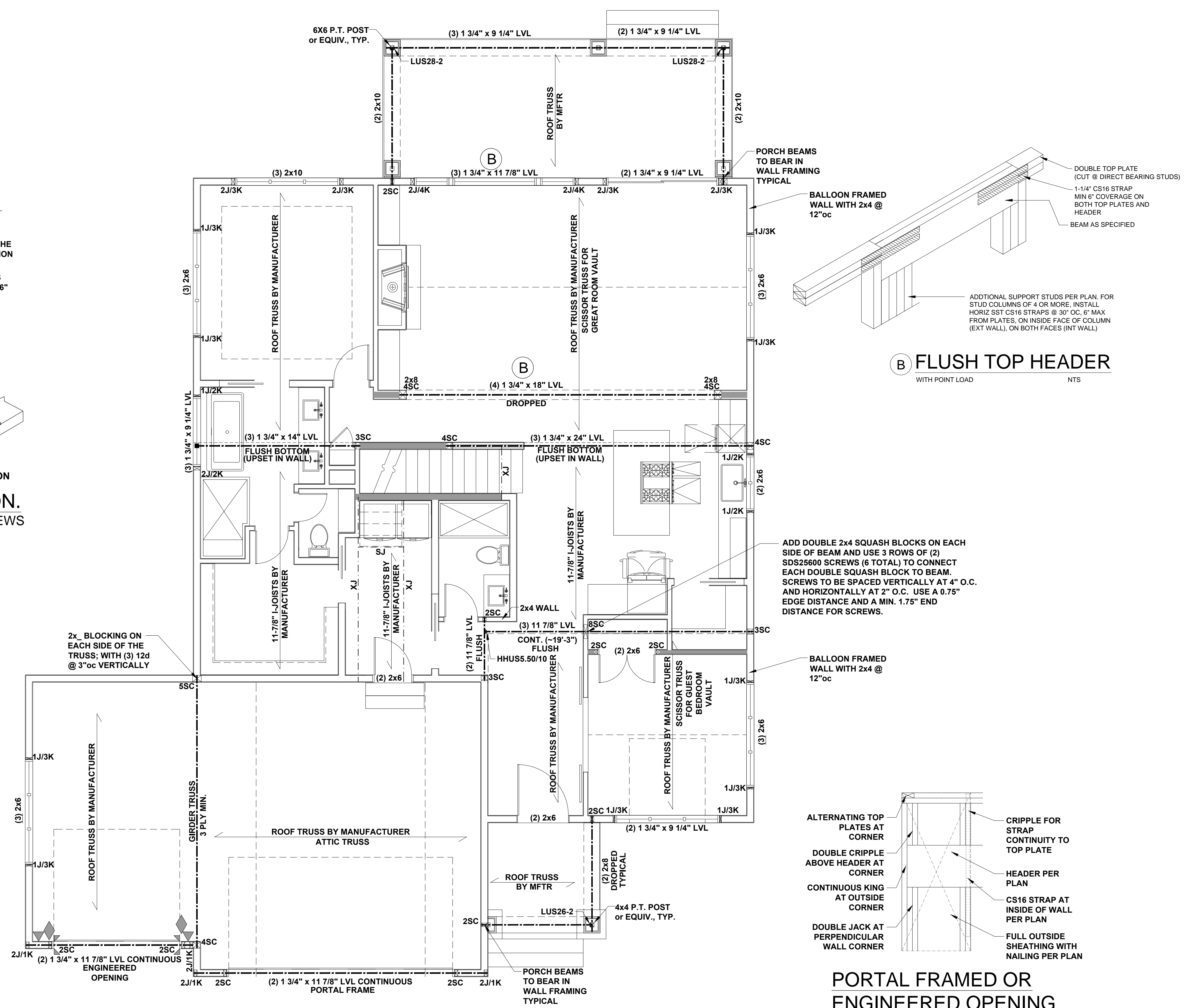

**PORTAL FRAMED OR ENGINEERED OPENING OUTSIDE CORNER DETAIL**

NTS

**FIRST FLOOR CEILING FRAMING PLAN**  
 SCALE: 1/4"=1'-0"

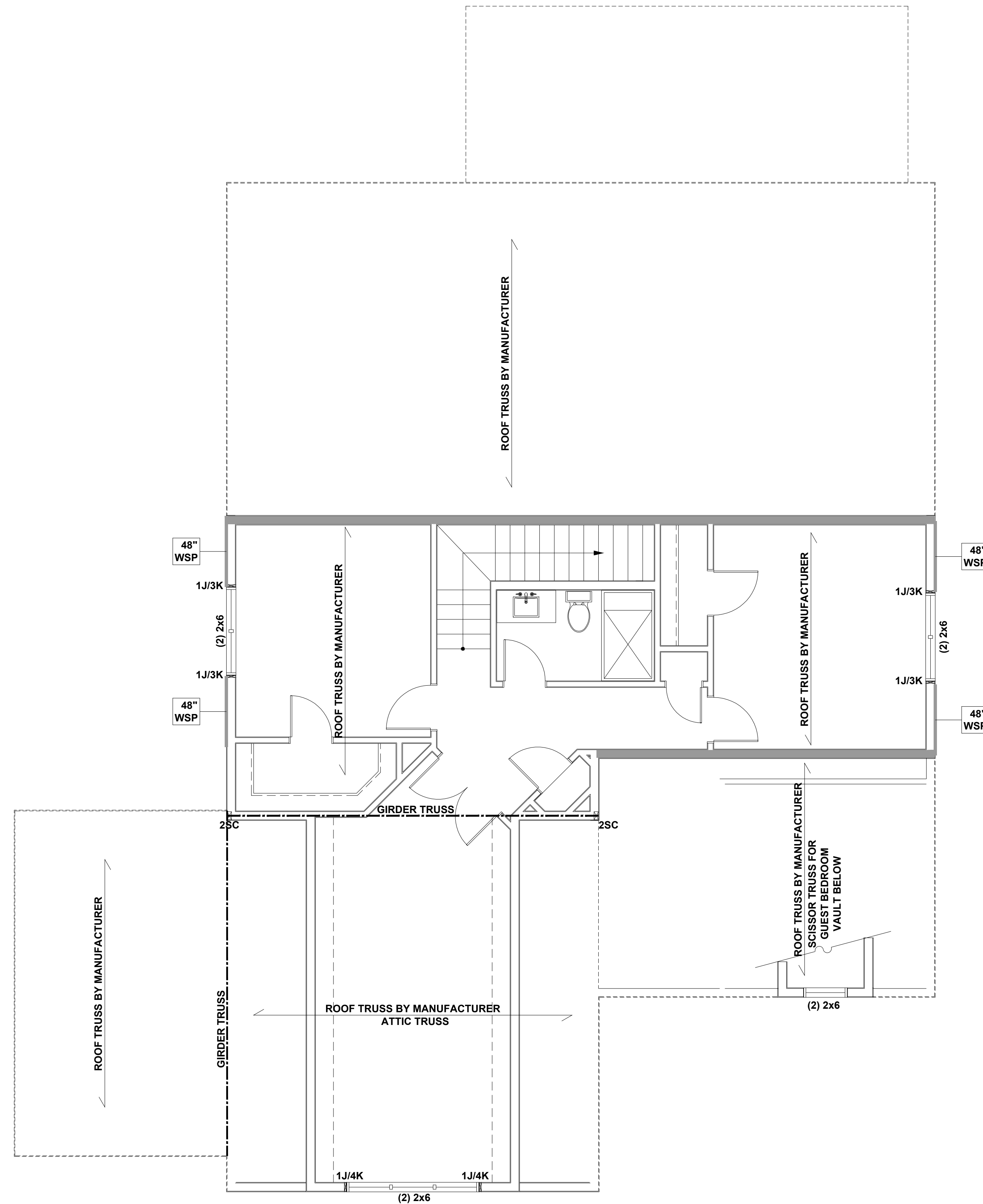

**SECOND FLOOR CEILING FRAMING PLAN**

SCALE: 1/4"=1'-0"

**BEAM & POINT LOAD LEGEND**

- INTERIOR LOAD BEARING WALL
- ROOF RAFTER / TRUSS SUPPORT
- DOUBLE RAFTER / DOUBLE JOIST
- STRUCTURAL BEAM / GIRDER
- WINDOW / DOOR HEADER
- POINT LOAD TRANSFER
- POINT LOAD FROM ABOVE BEARING ON BEAM / GIRDER

- STRUCTURAL FRAMING NOTES - (SEE GENERAL NOTES SHEET FOR ADDITIONAL REQUIREMENTS.)**
- ALL FRAMING TO BE #2 SPF MINIMUM.
  - ALL BEARING HEADERS TO BE (2) 2x6 SUPPORTED w/ MIN (1) JACK AND (1) KING EACH END, UNO.
  - EXTERIOR WALL OPENINGS OVER 3' TO HAVE MULTIPLE KING STUDS AS NOTED ON PLAN.
  - ALL NON-BEARING HEADERS TO BE (2) 2x4 (1) J / (1) K, UNO.
  - PROVIDE CONTINUOUS BLOCKING THROUGH STRUCTURE FOR ALL POINT LOADS.
  - ALL HANGERS AND CONNECTORS SPECIFIED ARE TO BE SIMPSON STRONG-TIE OR EQUIVALENT.
  - ALL BEAMS SPECIFIED ARE MINIMUM SIZES ONLY. LARGER MEMBERS MAY SUBSTITUTED AS NEEDED FOR EASE OF CONSTRUCTION. MINIMUM BEAM SUPPORT IS (1) 2x4 STUD.
  - ALL EXTERIOR WALLS TO BE FULLY SHEATHED WITH 7/16" OSB.
  - FRONT PORCH COLUMNS TO BE MIN 4x4 PT ATTACHED AT TOP AND BOTTOM USING SIMPSON (OR EQUIV) COLUMN BASE OR SST A24 BRACKETS. TRIM OUT PER BUILDER.
  - PORCH COLUMNS TO BE MIN 4x4 PT ATTACHED AT BOTTOM USING SIMPSON (OR EQUIV) ABA44 AND AT TOP USING CS 16 STRAPPING (12" MIN) TO PORCH HEADER / BAND.
  - WHEN A 4-PLY LVL IS USED, ATTACH WITH (1) 1/2" Ø BOLT 12" OC STAGGERED, TOP AND BOTTOM, 1-1/2" MIN FROM ENDS. ALTERNATE ATTACHMENT EQUIVALENT METHOD MAY BE USED, SUCH AS SDW OR TRUSSLOK SCREWS (SEE MANUFACTURER'S SPECIFICATIONS).
  - FOR STUD COLUMNS OF 4 OR MORE, INSTALL SST CS16 STRAPS @ 30" OC, 6" MAX FROM PLATES, ON INSIDE FACE OF COLUMN (EXTERIOR WALL), ON BOTH FACES OF COLUMN (INTERIOR WALL).

ALL FLUSH BEAMS TO BE DIRECTLY SUPPORTED BY (2) 2x STUDS UNLESS OTHERWISE NOTED. STUD COLUMNS TO BE SUPPORTED BY SOLID BLOCKING TO FOUNDATION OR TO BEARING COMPONENT BELOW.

ALL EXTERIOR WALLS TO BE 2X6 UNLESS NOTED OTHERWISE

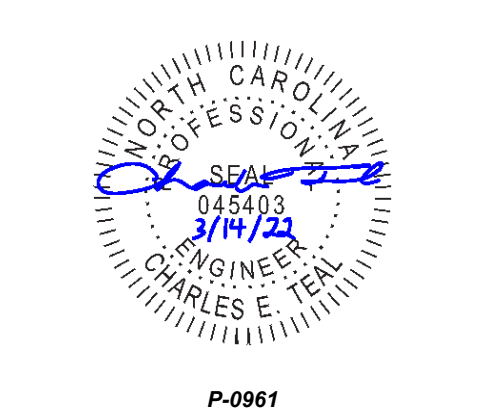

**JDS Consulting**  
ENGINEERING • DESIGN • ENERGY

JDS Consulting LLC, 8600 TY JERSEY CT, RALEIGH, NC 27617 919.480.1005  
INFO@JDSCONSULTING.NET WWW.JDSCONSULTING.NET

JDS Consulting PLLC IS NOT LIABLE FOR CHANGES MADE TO PLANS DUE TO CONSTRUCTION METHODS OR ANY CHANGES TO PLANS MADE IN THE FIELD. THE CLIENT ASSUMES ALL RESPONSIBILITY FOR THE ACCURACY OF THE INFORMATION ON THESE PLANS. THE CLIENT ASSUMES ALL RESPONSIBILITY FOR THE ACCURACY OF THE INFORMATION ON THESE PLANS. THE CLIENT ASSUMES ALL RESPONSIBILITY FOR THE ACCURACY OF THE INFORMATION ON THESE PLANS. THE CLIENT ASSUMES ALL RESPONSIBILITY FOR THE ACCURACY OF THE INFORMATION ON THESE PLANS.

CLIENT: **TRIANGLE BUILDING & PROPERTIES**

PROJECT: **CEDAR CREEK**

LOCATION: **NORTH CAROLINA**

SCALE: 1/4" = 1'-0" FOR 24x36 PAPER, NOT TO SCALE FOR 11x17 PAPER, OR AS NOTED

PROJECT NO.: **22900088**

DATE: **03/14/2022** DRAWN BY: **CAR**

SECOND FLOOR  
CEILING FRAMING PLAN

**S2.0**

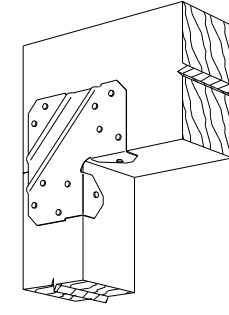

### LCE4 BRACING CON.

NTS

LCE4 CLIP TO HEADER JACK CONNECTION AND A35 CLIP AT THE JACK BOTTOM PLATE CONNECTION

CS16 STRAP FROM STUD, CROSS HEADER, TO WALL TOP PLATE, 36" LONG MIN.

SIMPSON HTT4 HOLD DOWN FOR ATTACHMENT TO CONCRETE OR MSTA18 STRAP FOR WOOD CONNECTIONS.

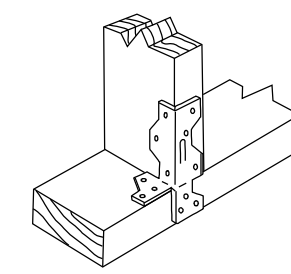

STANDARD INSTALLATION

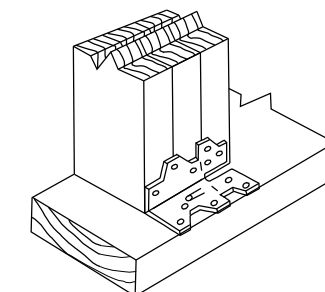

ALTERNATE INSTALLATION

### LOWER BRACING CON.

NTS

A35 CLIP WITH SD9112 SCREWS

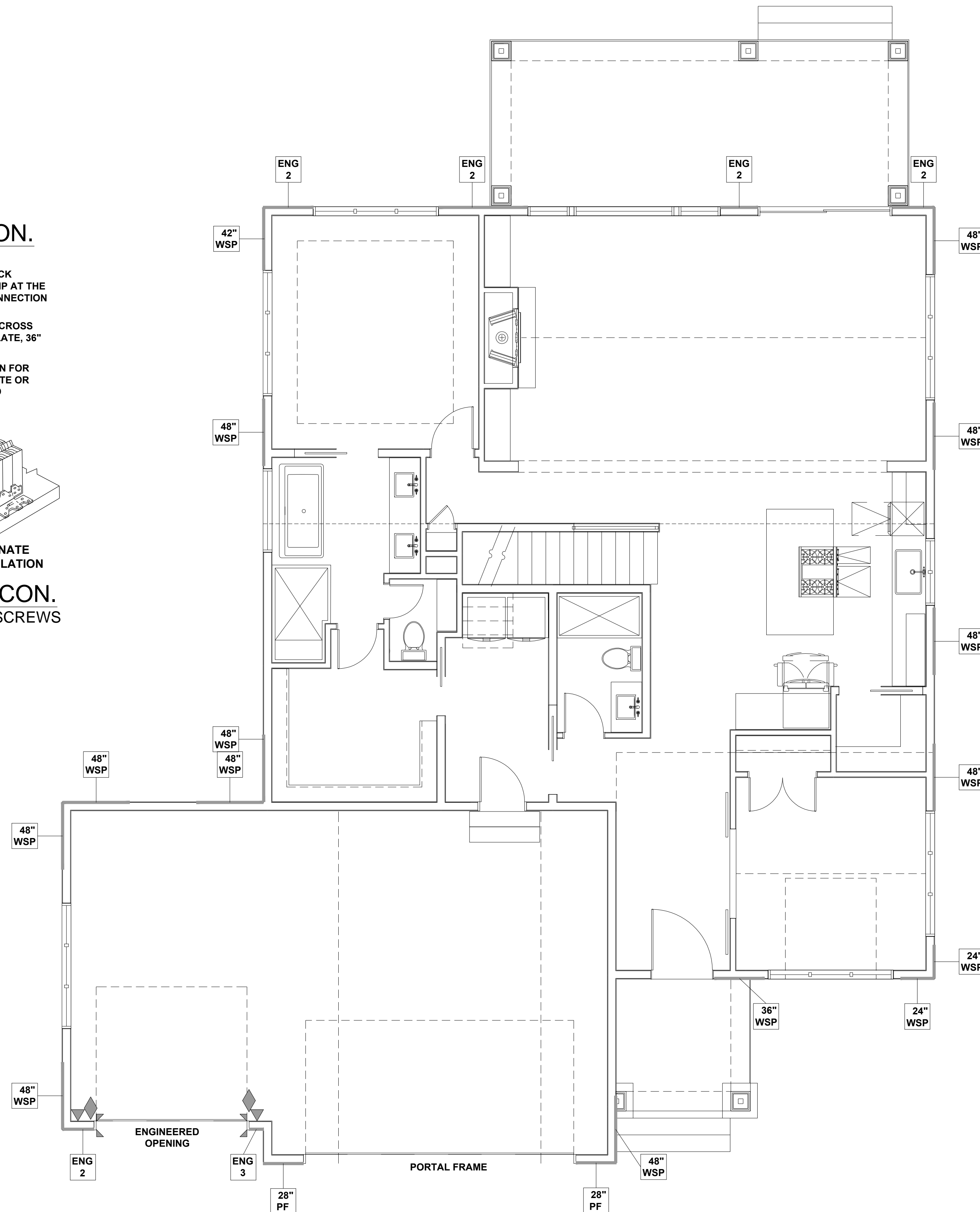

### WALL BRACING REQUIREMENTS

- MINIMUM PANEL WIDTH IS 24"
- FIGURES BASED ON THE CONTINUOUS SHEATHING METHOD USING THE RECTANGLE CIRCUMSCRIBED AROUND THE FLOOR PLAN OR PORTION OF THE FLOOR PLAN. IF NO RECTANGLE IS NOTED, THE STRUCTURE HAS BEEN FIGURED ALL WITHIN ONE RECTANGLE.
- ALL WSP NOTED ON PLAN ARE TO BE CONSIDERED CS-WSP
- PANELS MAY SHIFT UP TO 36" EITHER DIRECTION FOR EASE OF CONSTRUCTION (NAILING & BLOCK REQUIREMENTS STILL APPLY).
- FOR ADDITIONAL WALL BRACING INFORMATION, REFER TO WALL BRACING DETAIL SHEET(S).
- SCHEMATIC BELOW INDICATES HOW SIDES OF RECTANGLE ARE TO BE INTERPRETED IN BRACING CHART WHEN APPLIED TO STRUCTURE:

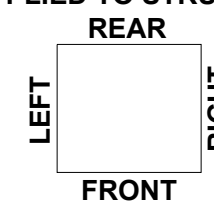

- CS16 STRAP FROM STUD, CROSS HEADER, TO WALL TOP PLATE, 36" LONG MINIMUM
- SIMPSON MSTA15 HOLD DOWN CAPACITY OF 970 POUNDS PER ANCHOR WITH (12) 10d NAILS. STRAP TO BE LOCATED AT EDGE OF BRACED WALL PANEL. (CS16 STRAPPING MAY BE SUBSTITUTED w/ SIMILAR LENGTH AND NAILING PATTERN.) USE HTT4 FOR ATTACHMENT TO CONCRETE.

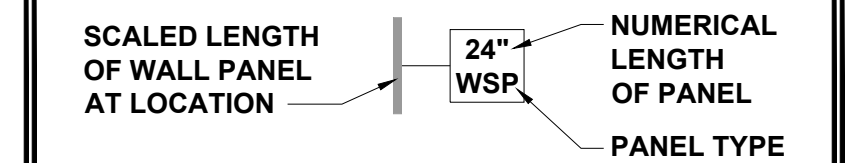

### WALL BRACING NOTE:

WALLS WITH PROVIDED LENGTH LISTED AS "N/A" DO NOT MEET THE REQUIREMENTS OF PRESCRIPTIVE WALL BRACING FOUND IN THE NCR. THESE WALLS ARE ENGINEERED DESIGN BASED ON DESIGN GUIDELINES ESTABLISHED IN ASCE-07 AND THE NDS: WIND & SEISMIC PROVISIONS SUPPLEMENT.

### ENGINEERED WALL SCHEDULE

- ENG1: CONTINUOUSLY SHEATH WITH 7/16" OSB ATTACHED WITH 8d NAILS @ 6" OC EDGE AND 12" OC FIELD. FULLY BLOCKED AT ALL PANEL EDGES.
- ENG2: CONTINUOUSLY SHEATH WITH 7/16" OSB WITH 10d NAILS @ 3" OC EDGE AND 3" OC FIELD. FULLY BLOCKED AT ALL PANEL EDGES.
- ENG3: CONTINUOUSLY SHEATH 7/16" OSB ATTACHED BOTH SIDES WITH 8d NAILS @ 4" OC EDGE AND 8" OC FIELD. FULLY BLOCKED AT ALL PANEL EDGES.
- ENG4: CONTINUOUSLY SHEATH 7/16" OSB ATTACHED WITH 8d NAILS @ 4" OC EDGE AND 8" OC FIELD. FULLY BLOCKED AT ALL PANEL EDGES.

### WALL BRACING: RECTANGLE 1

SIDE	REQUIRED LENGTH	PROVIDED LENGTH
FRONT	16.0 FT.	N/A
RIGHT	15.0 FT.	22.0 FT.
REAR	16.0 FT.	N/A
LEFT	15.0 FT.	19.0 FT.

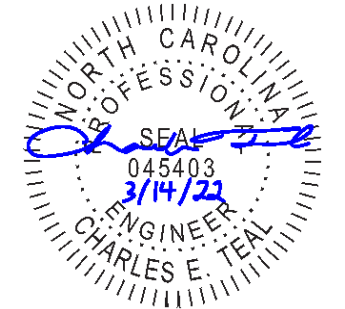

P-0961



JDS Consulting, LLC, 8600 W. JERSEY CT. RALEIGH, NC 27617-9040-1005  
 INFO@JDSCONSULTING.NET WWW.JDSCONSULTING.NET  
 JDS Consulting, LLC IS NOT LIABLE FOR CHANGES MADE TO PLANS DUE TO CONSTRUCTION METHODS OR ANY CHANGES TO PLANS MADE IN THE FIELD. THE LOT NUMBER, PROPERTY OR ASA MASTER PLAN AS SPECIFIED ON TITLE SHEET, DIMENSIONS, SHALL GOVERN OVER SCALE, AND CODE SHALL GOVERN OVER DIMENSIONS ON DRAWINGS.

CLIENT: TRIANGLE BUILDING & PROPERTIES  
 PROJECT: CEDAR CREEK  
 LOCATION: NORTH CAROLINA

PROJECT NO.: 22900088

DATE: 03/14/2022 DRAWN BY: CAR

FIRST FLOOR WALL BRACING PLAN

S4.0

## FIRST FLOOR WALL BRACING PLAN

SCALE: 1/4"=1'-0"

SCALE: 1/4" = 1'-0" FOR 24x36 PAPER, NOT TO SCALE FOR 11x17 PAPER, OR AS NOTED

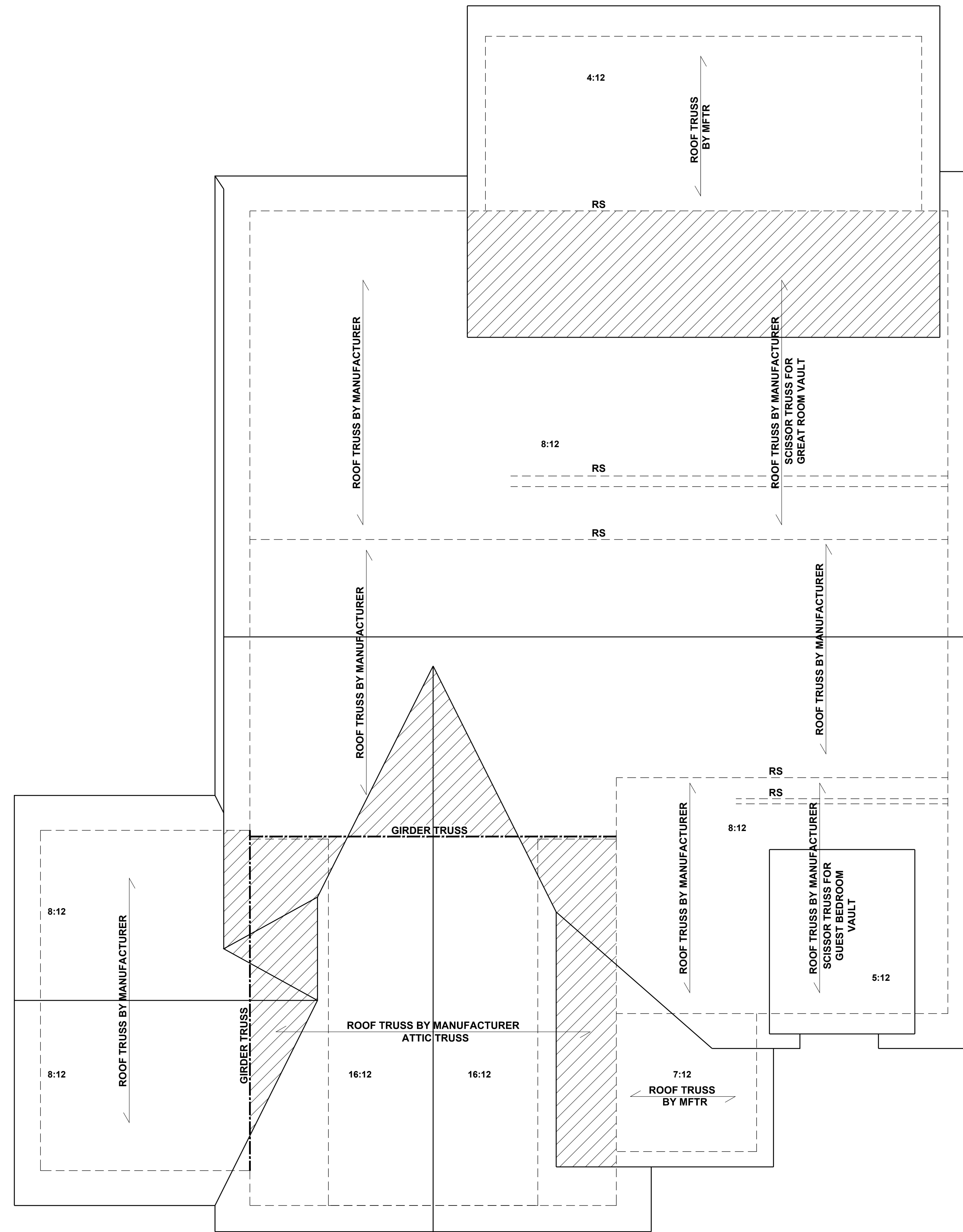

**ROOF FRAMING PLAN**

SCALE: 1/4"=1'-0"

**BEAM & POINT LOAD LEGEND**

	INTERIOR LOAD BEARING WALL
	ROOF RAFTER / TRUSS SUPPORT
	DOUBLE RAFTER / DOUBLE JOIST
	STRUCTURAL BEAM / GIRDER
	WINDOW / DOOR HEADER
	POINT LOAD TRANSFER
	POINT LOAD FROM ABOVE BEARING ON BEAM / GIRDER

- TRUSSED ROOF - STRUCTURAL NOTES**
- PROVIDE CONTINUOUS BLOCKING THROUGH STRUCTURE FOR ALL POINT LOADS.
  - DENOTES OVER-FRAMED AREA
  - MINIMUM 7/16" OSB ROOF SHEATHING
  - TRUSS LAYOUT AND PLACEMENT BY MANUFACTURER TO COINCIDE WITH THE SUPPORT LOCATIONS SHOWN. TRUSS PROFILES SHALL BE SEALED BY THE TRUSS MANUFACTURER. TRUSS PLANS TO BE COORDINATED WITH THE SEALED STRUCTURAL DRAWINGS. INSTALLATION SHALL BE IN ACCORDANCE WITH THE MANUFACTURER'S INSTRUCTIONS.
  - MANUFACTURER TO PROVIDE REQUIRED UPLIFT CONNECTION.
  - PROVIDE H2.5A (MINIMUM) OR EQUIVALENT AT EACH TRUSS-TO-TOP PLATE CONNECTION AT OVER-FRAMED AREAS, UNLESS NOTED OTHERWISE.
  - UPLIFT CONNECTION TO BE CARRIED THROUGH TO FLOOR SYSTEM.

**ATTIC VENTILATION**

THE TOTAL NET-FREE VENTILATION AREA SHALL NOT BE LESS THAN 1/150 OF THE AREA OF THE ATTIC SPACE TO BE VENTILATED. THE TOTAL VENTILATION MAY BE REDUCED TO 1/300 PROVIDED AT LEAST 50% BUT NOT MORE THAN 80% OF THE REQUIRED VENTILATION BE LOCATED IN THE UPPER PORTION OF THE AREA TO BE VENTILATED, OR AT LEAST 3' ABOVE THE SOFFIT VENTILATION INTAKE.

3016	SQUARE FEET OF TOTAL ATTIC / 150 =
20.25	SQUARE FEET OF NET-FREE VENTILATION REQUIRED

**TRUSS UPLIFT CONNECTORS: EXPOSURE B, 115 MPH, ANY PITCH, 24" O.C. MAX ROOF TRUSS SPACING**

TRUSSES SHALL BE ATTACHED TO SUPPORT WALL FOR UPLIFT RESISTANCE. CONTINUOUS OSB WALL SHEATHING BELOW PROVIDES CONTINUOUS UPLIFT RESISTANCE TO FOUNDATION. ALL TRUSSES SUPPORTED BY INTERMEDIATE SUPPORT WALLS, KNEEWALLS, OR BEAMS SHALL BE ATTACHED TO SUPPORTING MEMBER PER SCHEDULE:

ROOF SPAN IS MEASURED HORIZONTALLY BETWEEN FURTHEST SUPPORT POINTS.

<b>ROOF PLAN</b>	<b>CONNECTOR</b>
UP TO 28'	NAILING PER TABLE 602.3(1) NCRBC 2018 EDITION
OVER 28'	(1) SIMPSON H2.5A HURRICANE CLIP TO DBL TOP PLATE OR BEAM OR (1) SIMPSON H3 CLIP TO SINGLE 2x4 PLATE



**JDS Consulting**  
ENGINEERING • DESIGN • ENERGY

JDS Consulting LLC, 8600 TP JERSEY CT, RALEIGH, NC 27617 919.480.1005  
INFO@JDSCONSULTING.NET WWW.JDSCONSULTING.NET

JDS Consulting LLC IS NOT LIABLE FOR CHANGES MADE TO PLANS DUE TO CONSTRUCTION METHODS OR ANY CHANGES TO PLANS MADE IN THE FIELD. THE LOT NUMBER, PROPERTY OR ASA MASTER PLAN AS SPECIFIED ON TITLE SHEET. DIMENSIONS SHALL GOVERN OVER SCALE, AND CODE SHALL GOVERN OVER DIMENSIONS ON DRAWINGS.

**CLIENT: TRIANGLE BUILDING & PROPERTIES**

**PROJECT: CEDAR CREEK**

**LOCATION: NORTH CAROLINA**

SCALE: 1/4" = 1'-0" FOR 24x36 PAPER, NOT TO SCALE FOR 11x17 PAPER, OR AS NOTED

PROJECT NO.: **22900088**

DATE: **03/14/2022** DRAWN BY: **CAR**

ROOF FRAMING PLAN

**S6.0**

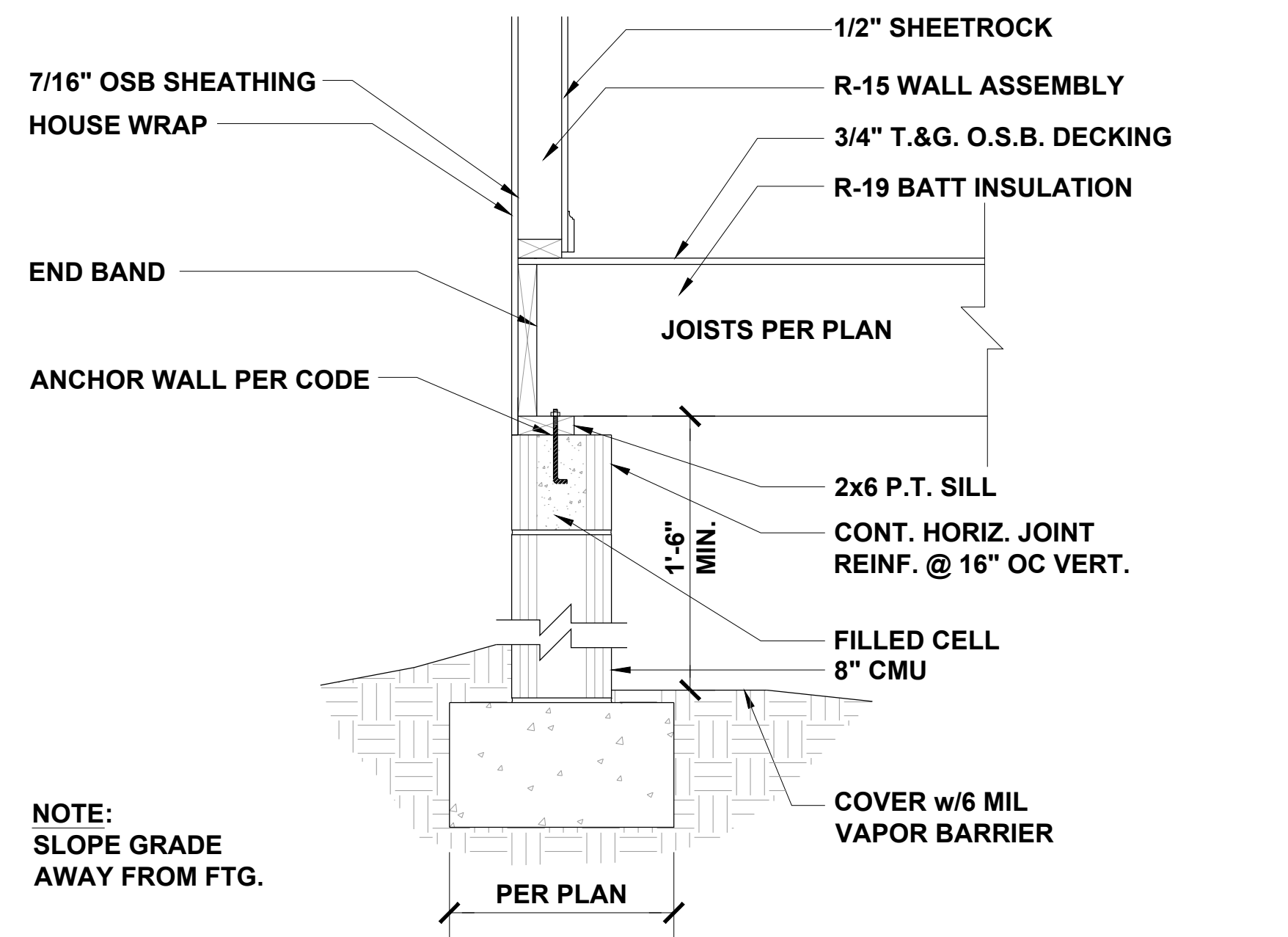

**CRAWL AT EXTERIOR WALL** 1/2" = 1'-0" **1**

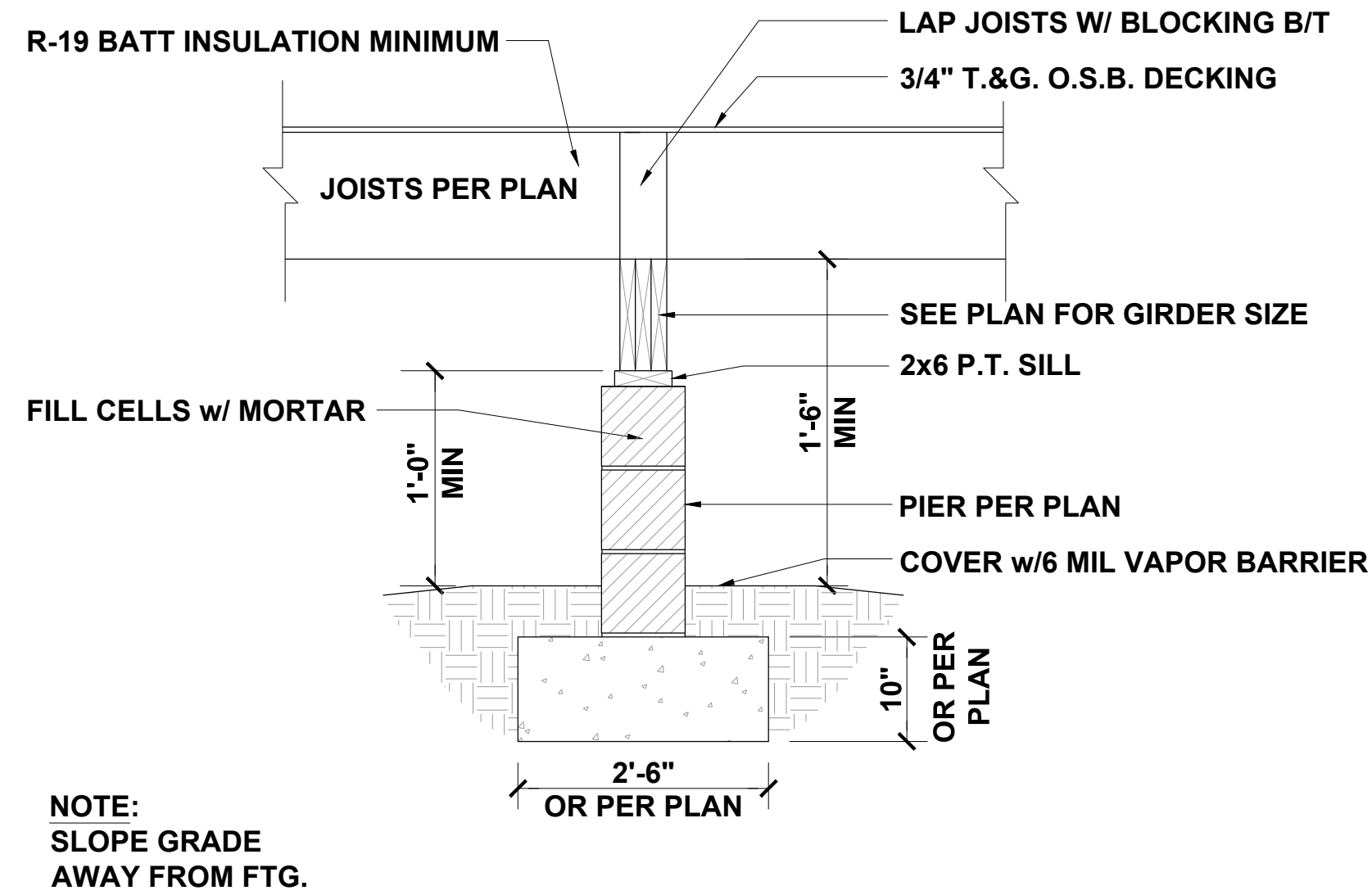

**PIER AND GIRDER** 1/2" = 1'-0" **2**

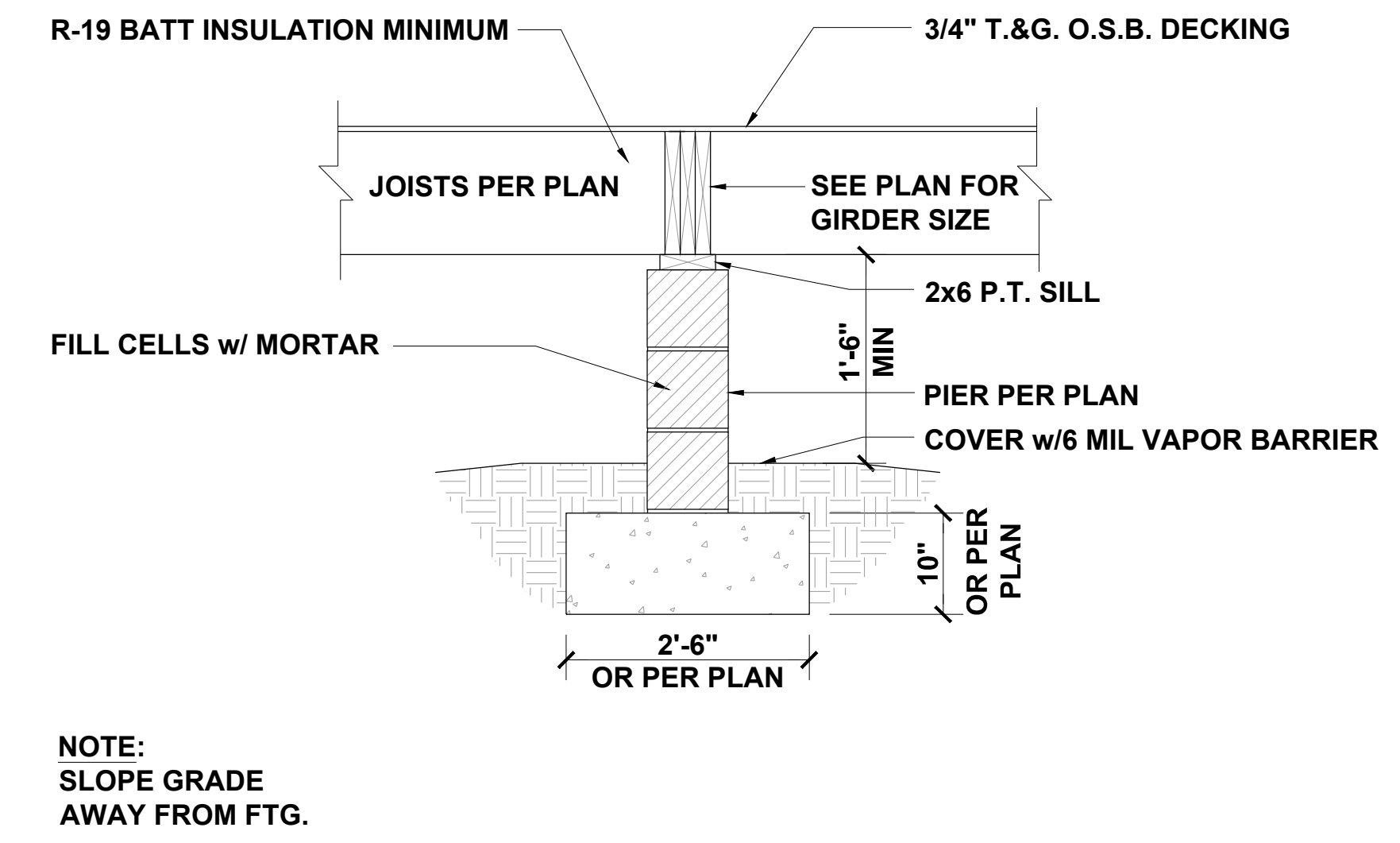

**PIER AND FLUSH GIRDER** 3/8" = 1'-0" **3**

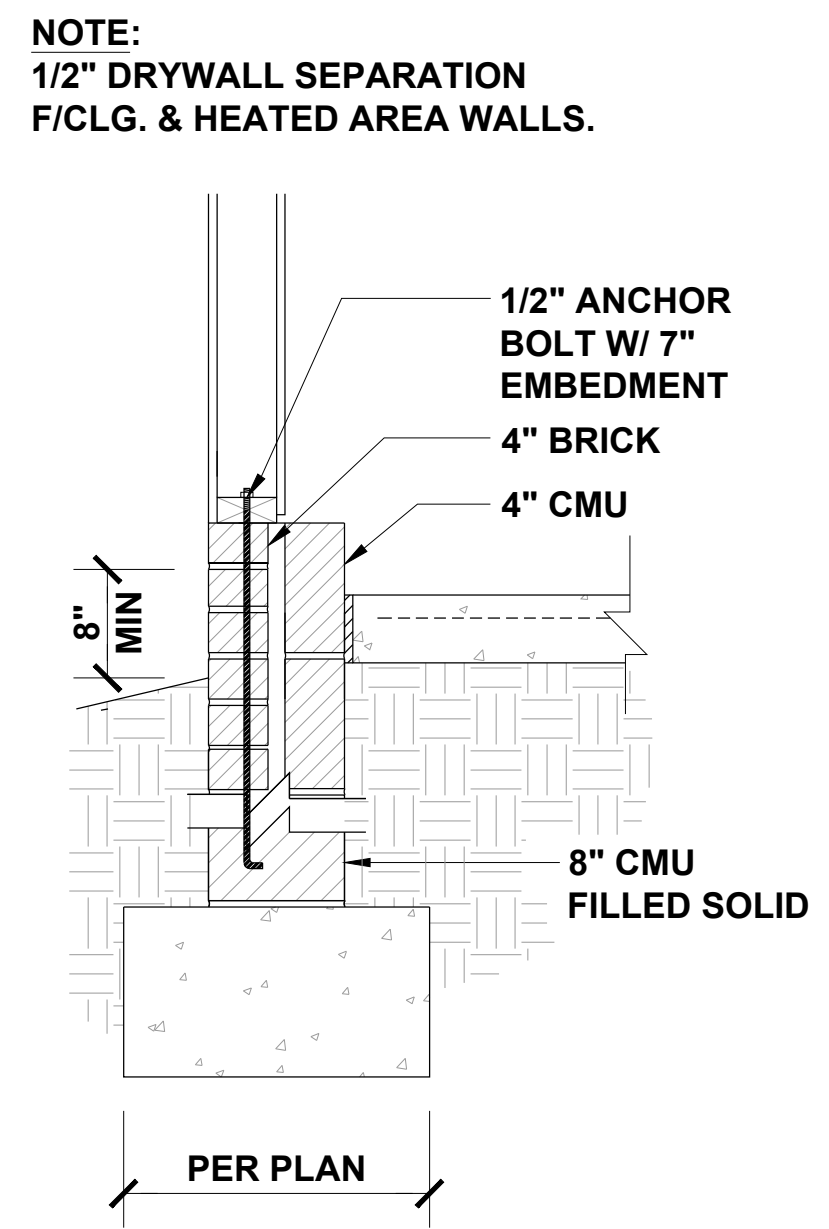

**GARAGE FOUNDATION** 1/2" = 1'-0" **4**

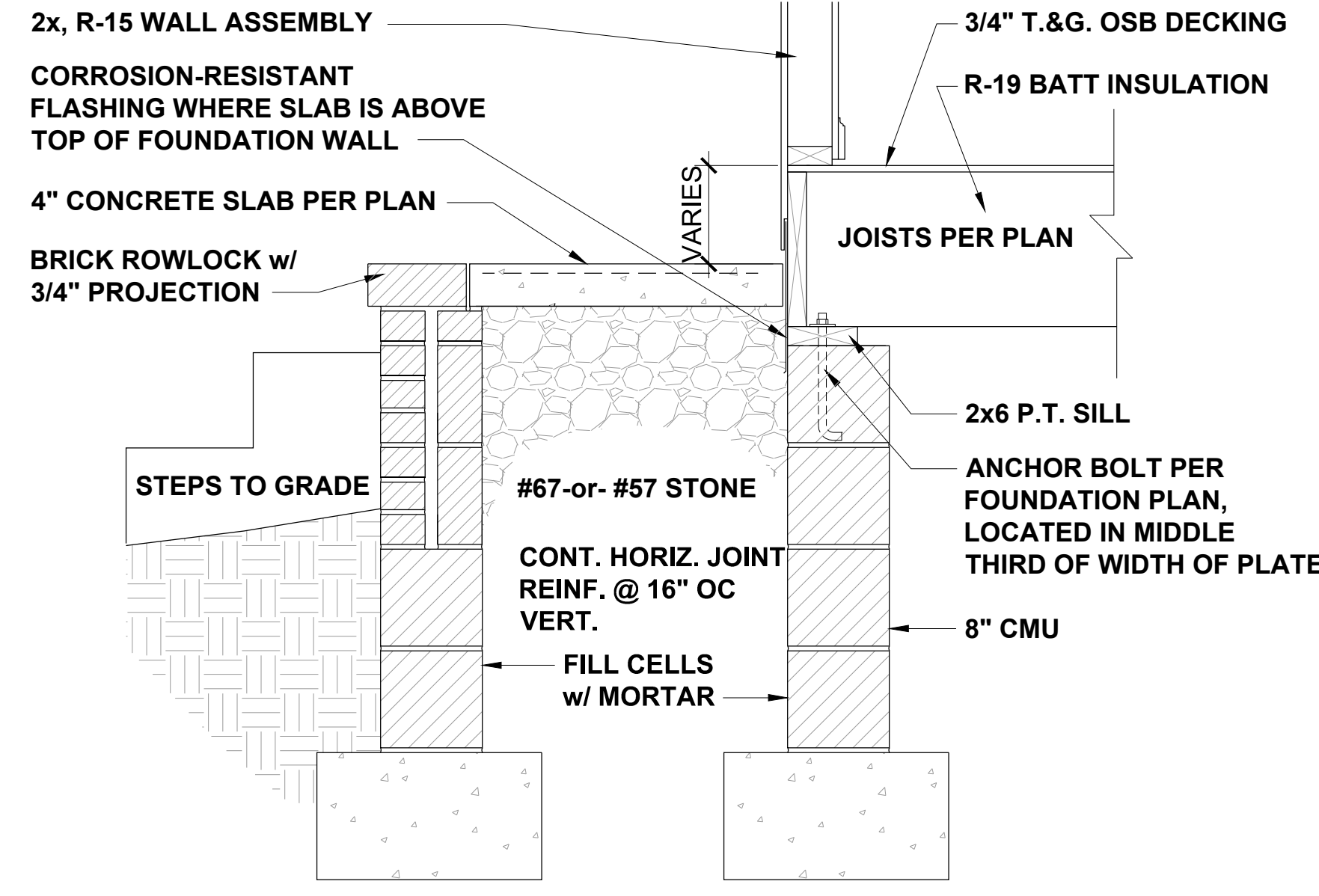

**FRONT PORCH SECTION** 1/2" = 1'-0" **5**

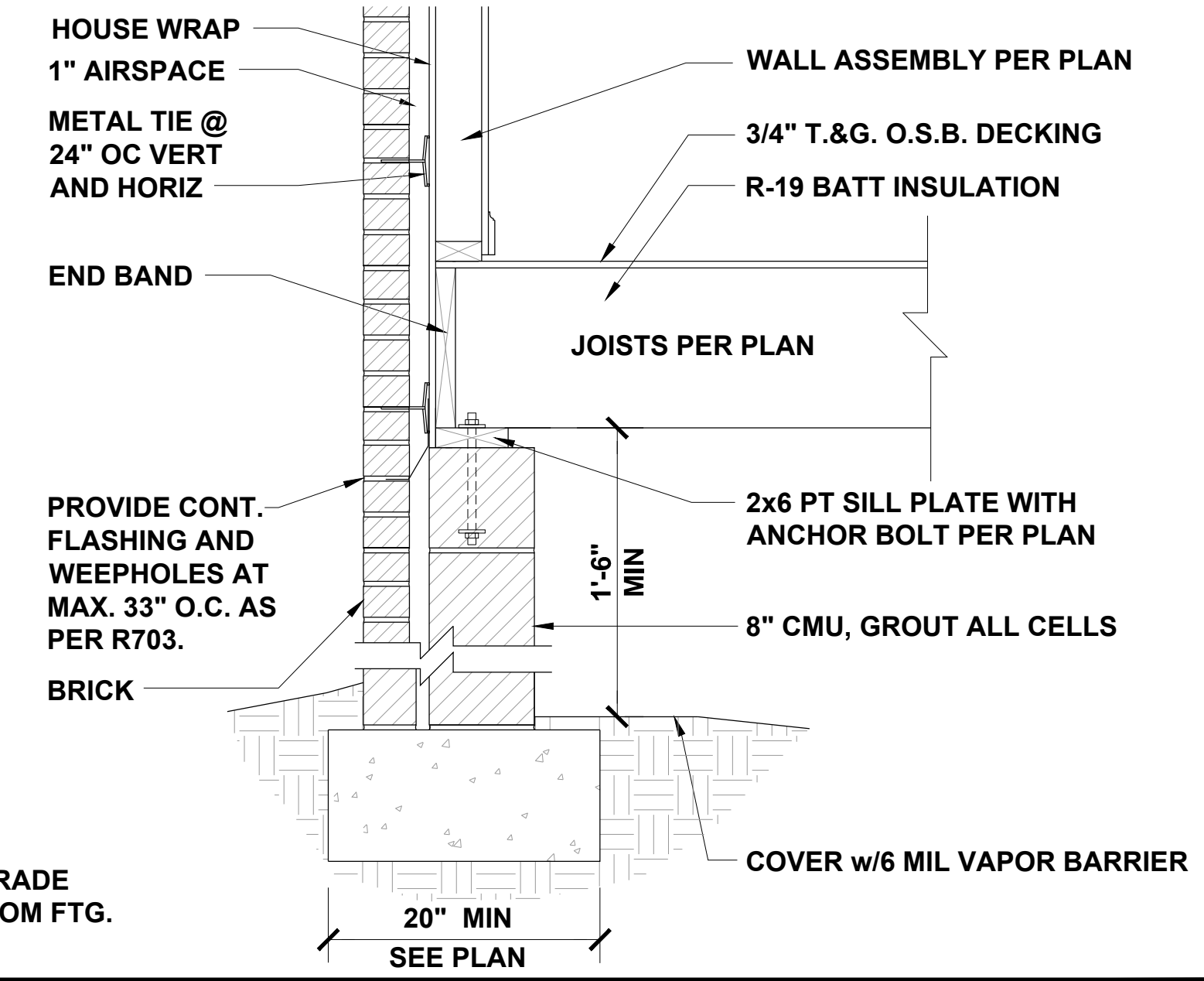

**CRAWL AT EXTERIOR WALL** 1/2" = 1'-0" **6**

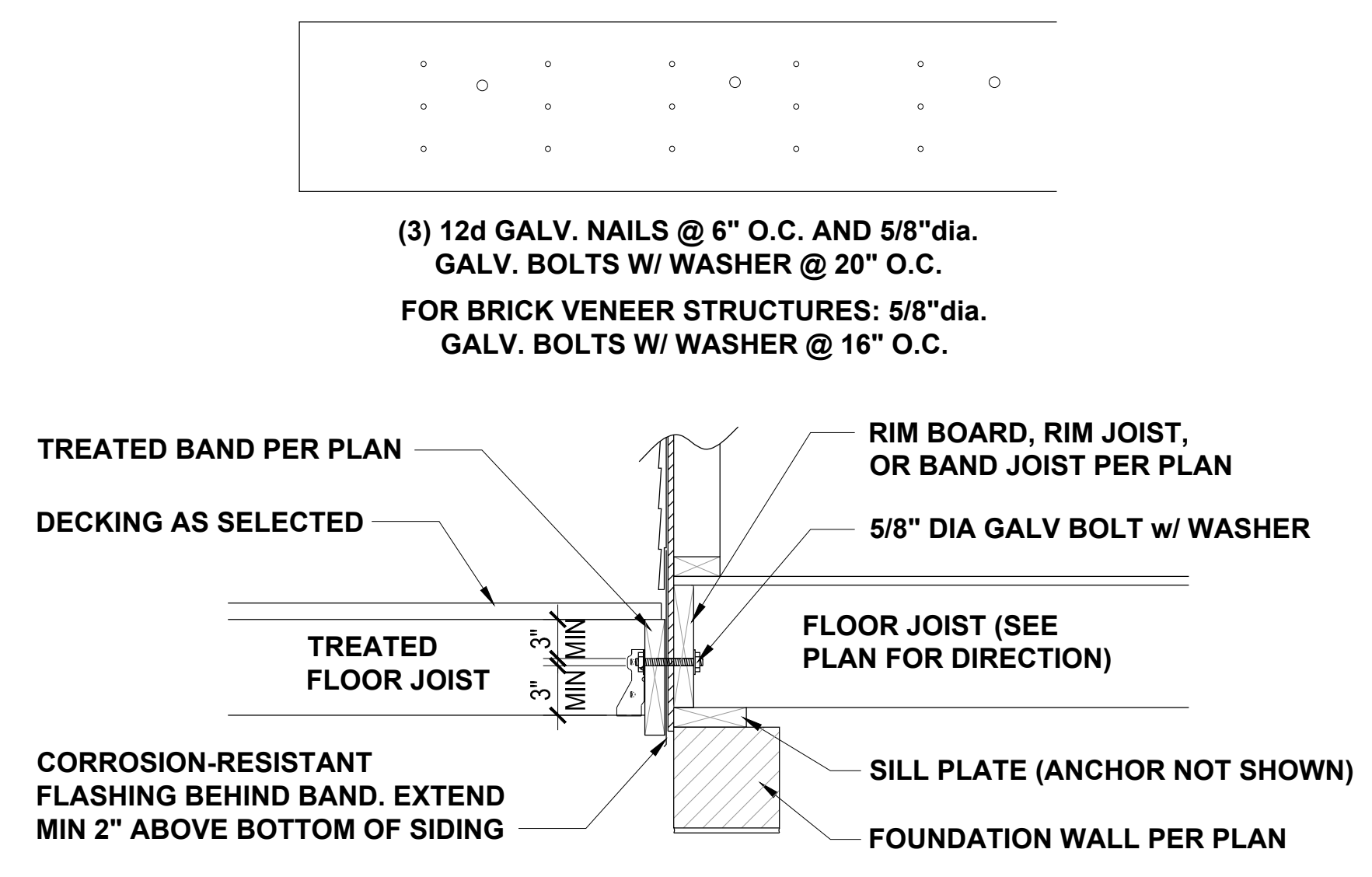

**DECK ATTACHMENT** 1/2" = 1'-0" **7**

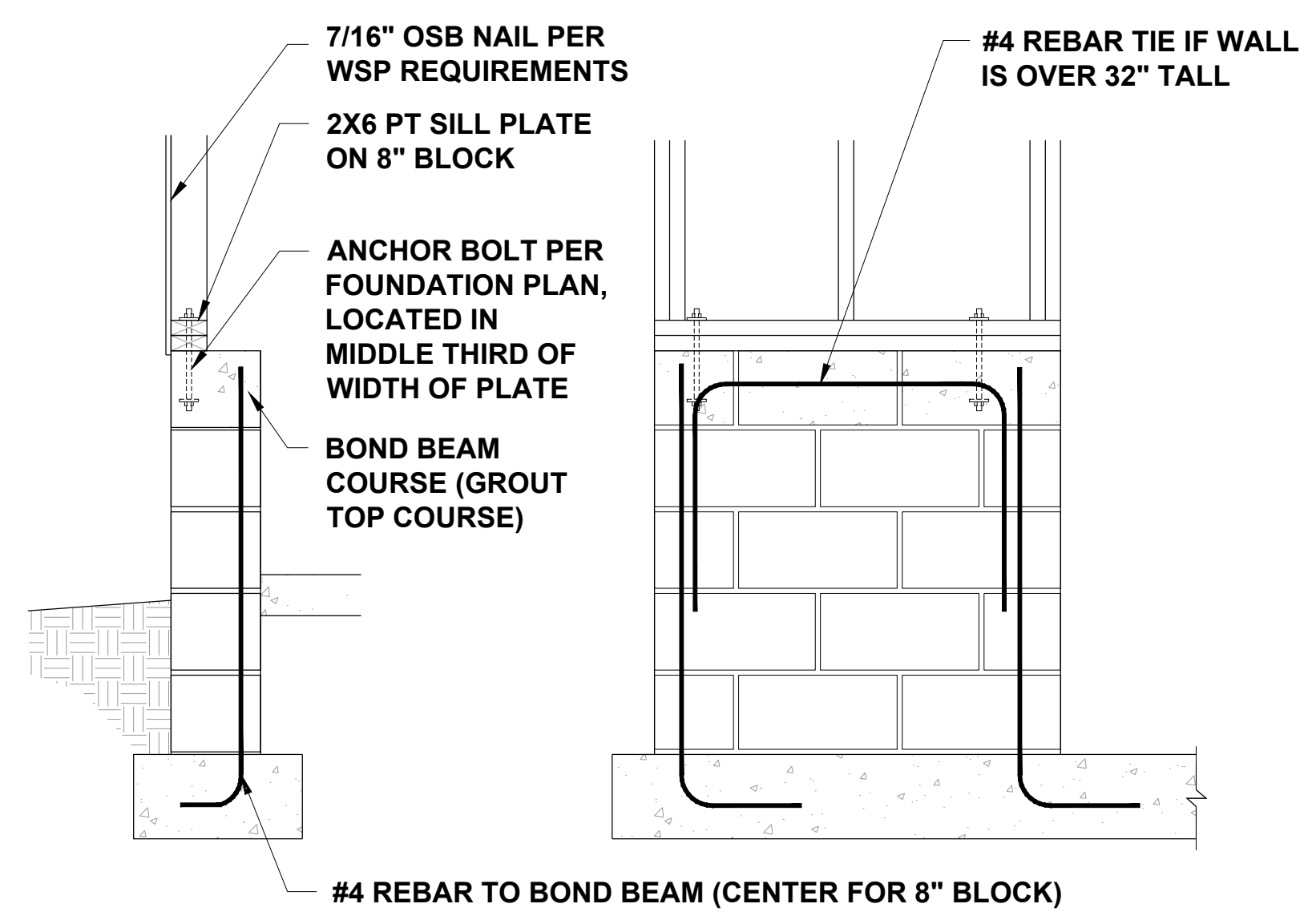

**GARAGE WING WALL** 3/8" = 1'-0" **8**

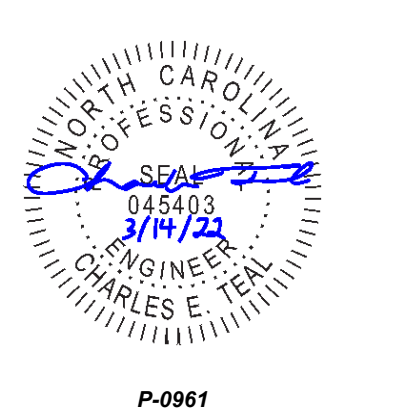

**JDS Consulting**  
ENGINEERING • DESIGN • ENERGY

JDS Consulting, LLC, 3600 TYP. JERSEY CT. RALEIGH, NC 27607-9040-105  
INFO@JDSCONSULTING.NET WWW.JDSCONSULTING.NET

JDS Consulting, LLC IS NOT LIABLE FOR CHANGES MADE TO PLANS DUE TO CONSTRUCTION METHODS OR ANY CHANGES TO PLANS MADE IN THE FIELD. THE CONTRACTOR SHALL BE RESPONSIBLE FOR VERIFYING ALL DIMENSIONS, SHEET DIMENSIONS, SHALL GOVERN OVER SCALE, AND CODE SHALL GOVERN OVER DIMENSIONS ON DRAWINGS.

CLIENT: **TRIANGLE BUILDING & PROPERTIES**

PROJECT: **CEDAR CREEK**

LOCATION: **NORTH CAROLINA**

SCALE: 1/4" = 1'-0" FOR 24x36 PAPER, NOT TO SCALE FOR 11x17 PAPER, OR AS NOTED

PROJECT NO.: **22900088**

DATE: **03/14/2022** DRAWN BY: **CAR**

**CRAWL SPACE FOUNDATION DETAILS**

**D1.0**



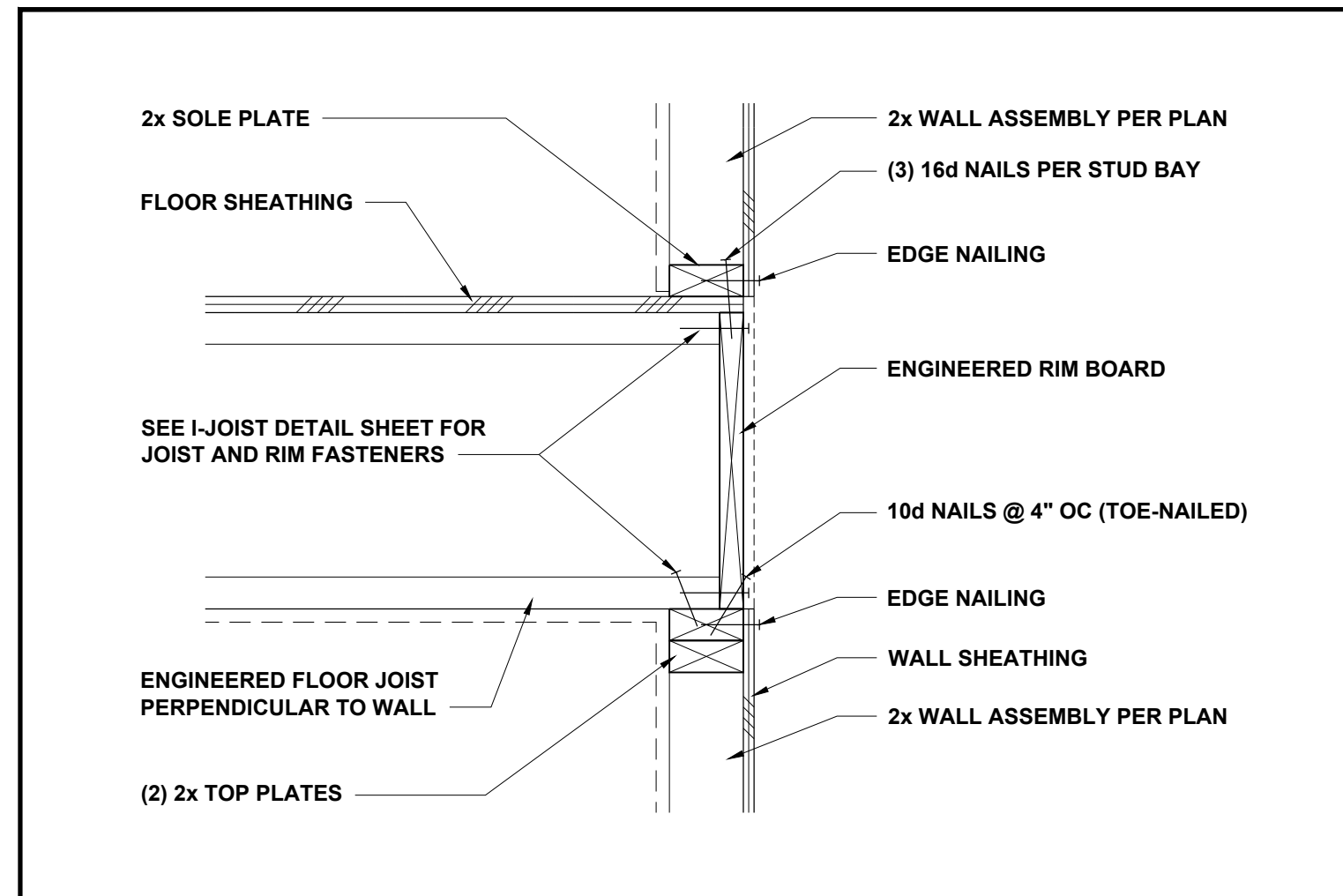

**FLOOR JOISTS PERP TO WALL** 1 1/2" = 1'-0" **1**

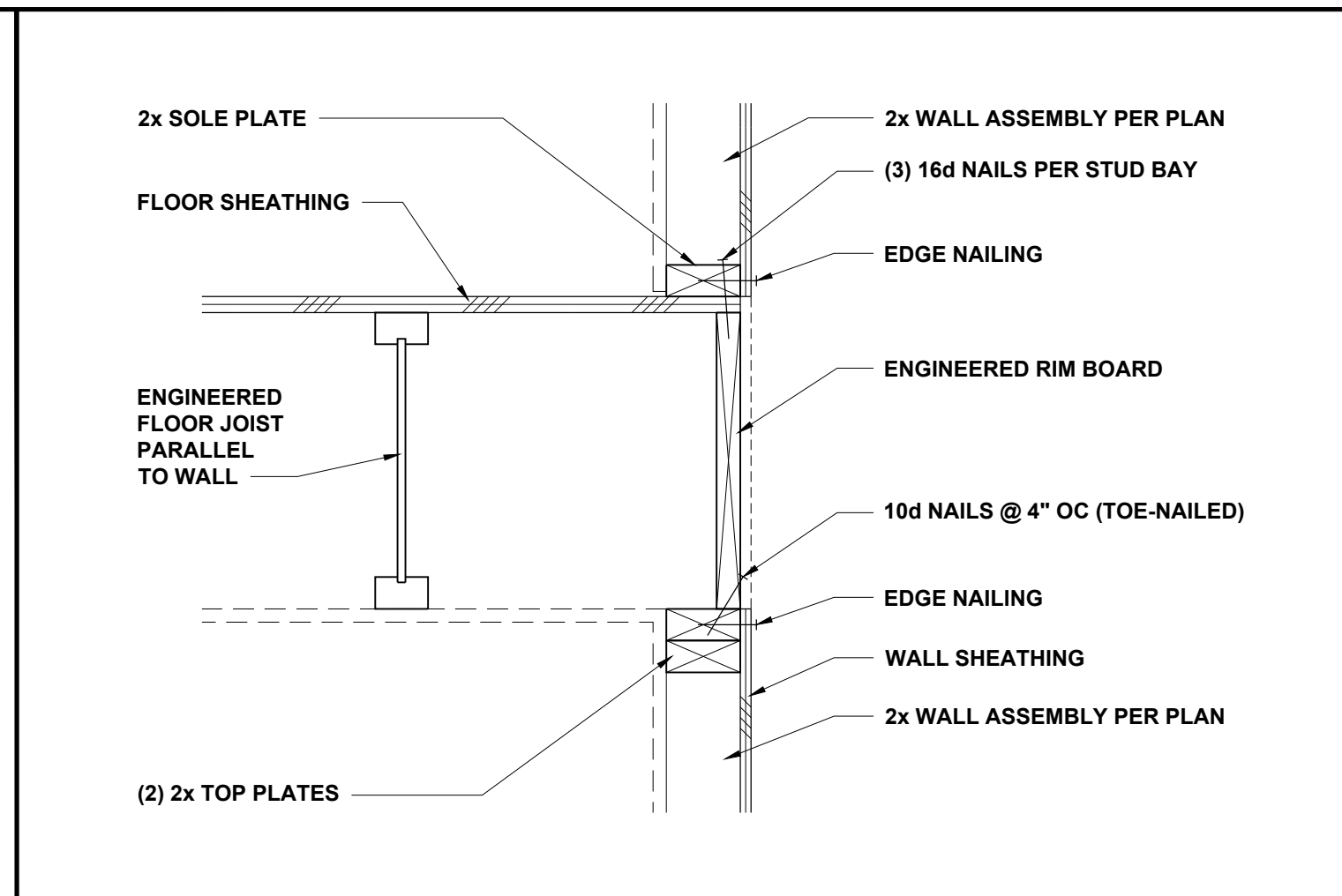

**FLOOR JOISTS PARALLEL TO WALL** 1 1/2" = 1'-0" **2**

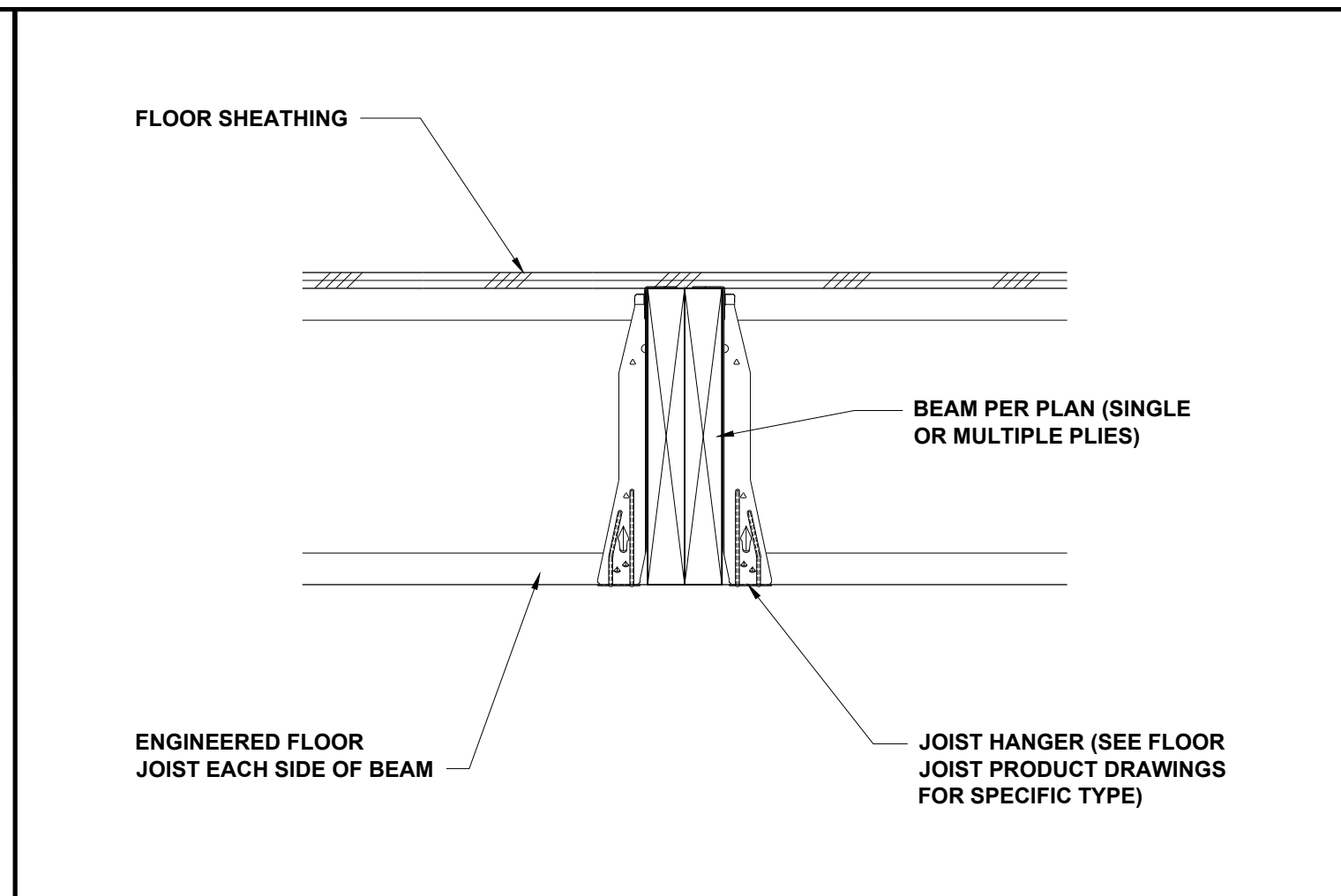

**FLOOR JOISTS AT FLUSH BEAM** NTS **3**

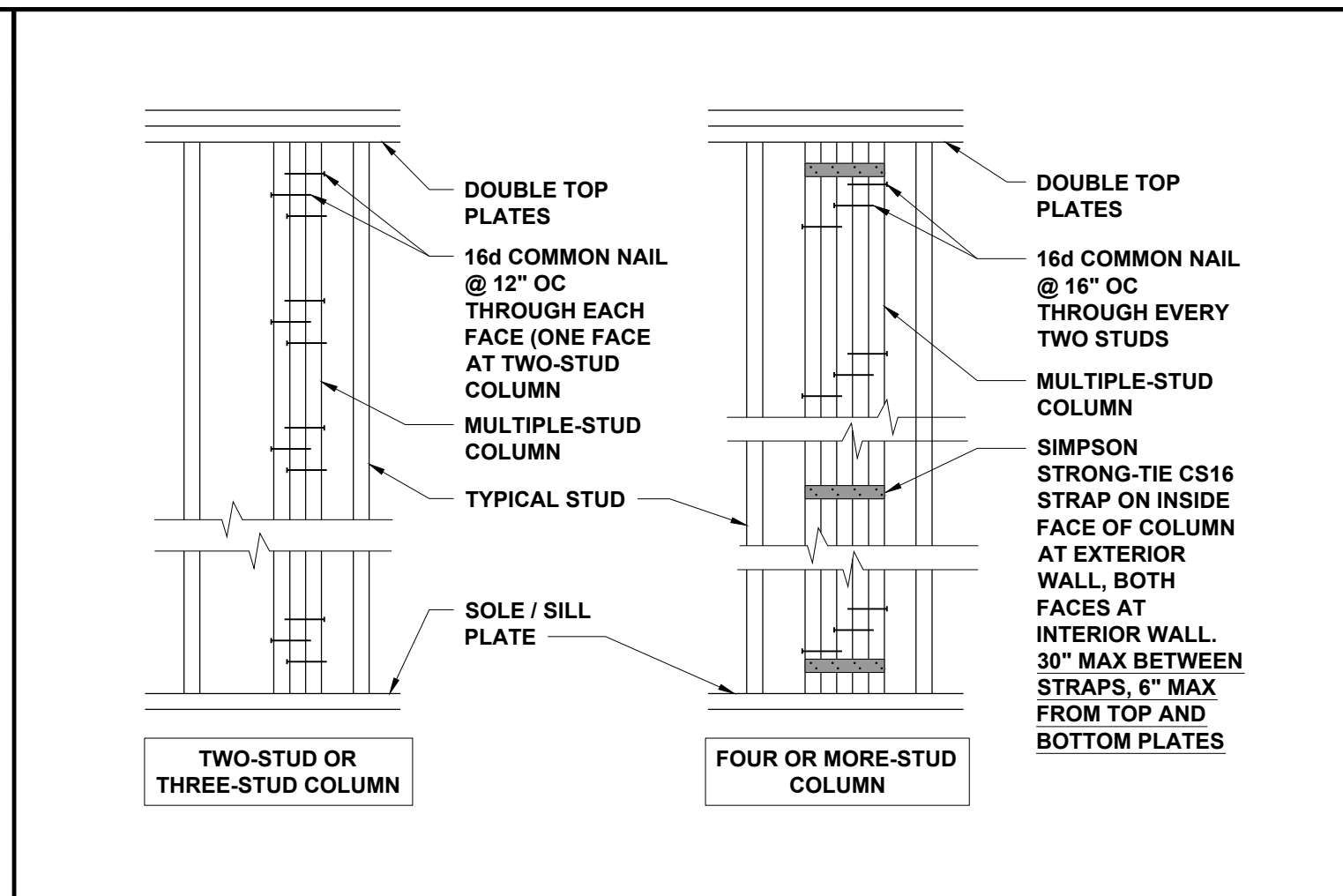

**MULTIPLE-STUD COLUMN FASTENING** 3/4" = 1'-0" **4**

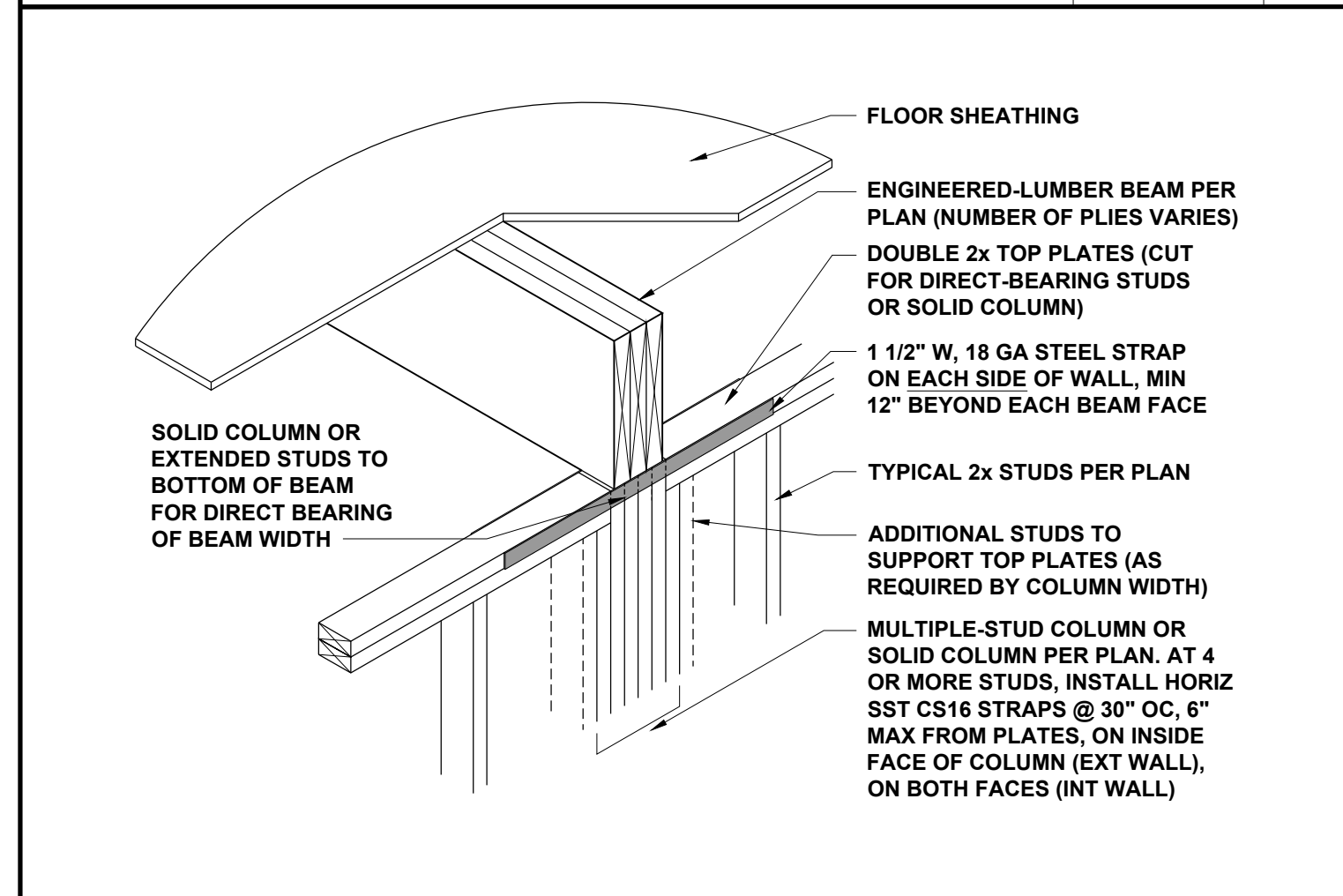

**FLUSH BEAM AT WALL** 3/4" = 1'-0" **5**

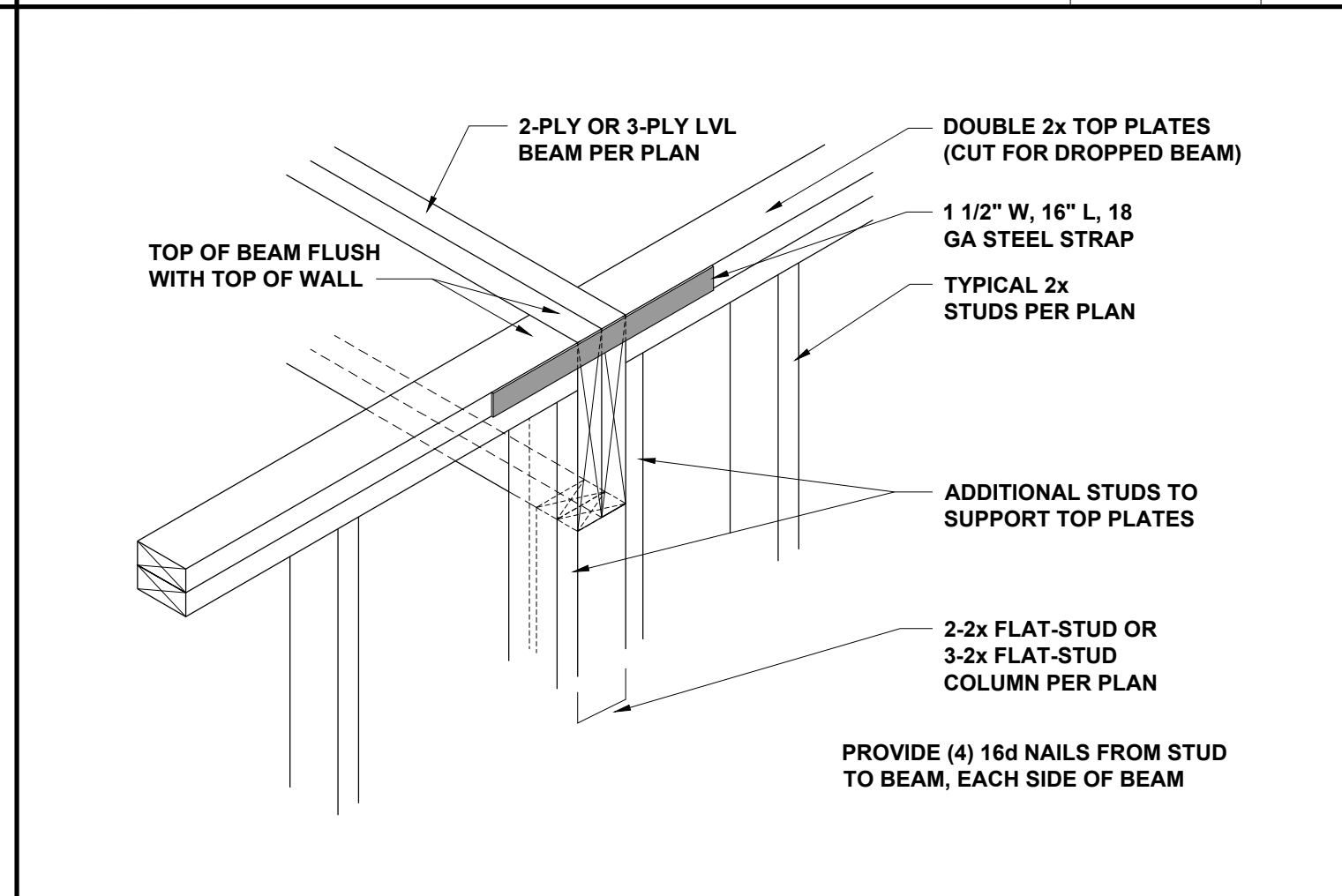

**DROPPED LVL BEAM AT WALL** NTS **6**

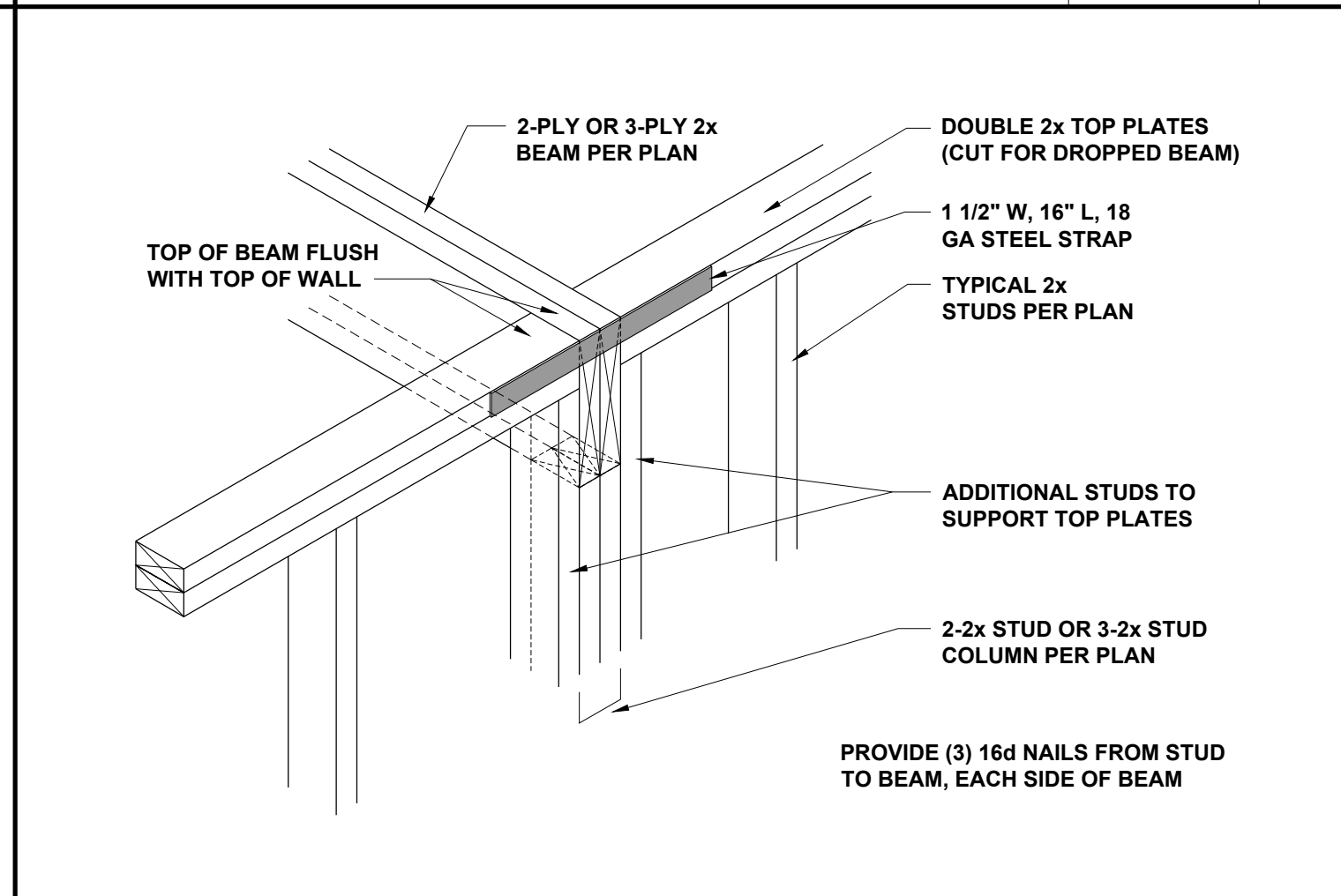

**DROPPED 2x BEAM AT WALL** NTS **7**

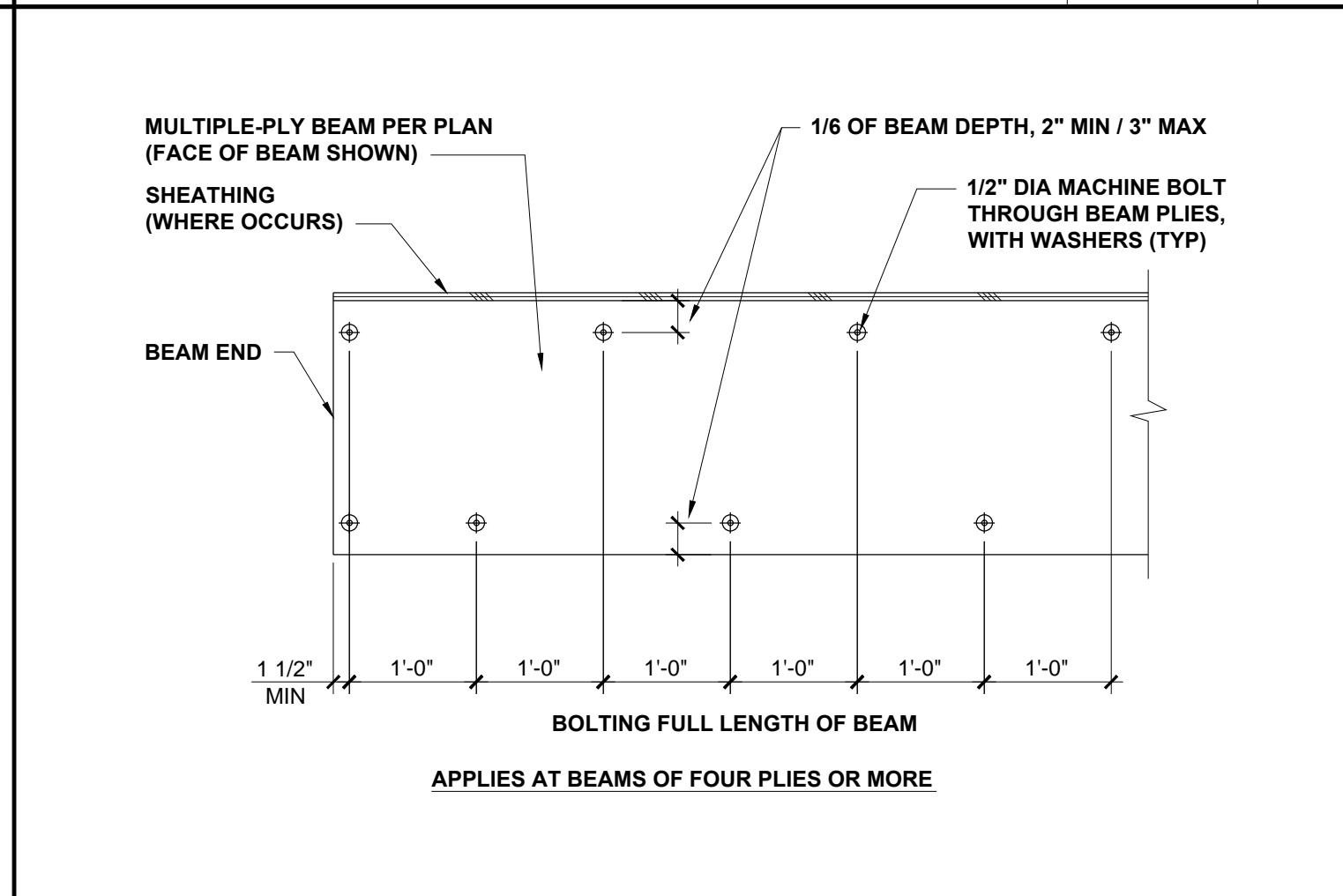

**MULTIPLE-PLY BEAM BOLTING** 3/4" = 1'-0" **8**

P-0961

**JDS Consulting**  
 ENGINEERING • DESIGN • ENERGY  
JDS Consulting, LLC, 1600 TD JERSEY CT, RALEIGH, NC 27617 919.480.1005  
 INFO@JDSCONSULTING.NET WWW.JDSCONSULTING.NET

JDS Consulting, LLC IS NOT LIABLE FOR CHANGES MADE TO PLANS DUE TO CONSTRUCTION METHODS OR ANY CHANGES TO PLANS MADE IN THE FIELD. THE LOT NUMBER, PROPERTY OR ASA MASTER PLAN AS SPECIFIED ON TITLE SHEET, DIMENSIONS SHALL GOVERN OVER SCALE, AND CODE SHALL GOVERN OVER DIMENSIONS ON DRAWINGS.

**CLIENT: TRIANGLE BUILDING & PROPERTIES**  
**PROJECT: CEDAR CREEK**  
**LOCATION: NORTH CAROLINA**

PROJECT NO.: **22900088**  
 DATE: **03/14/2022** DRAWN BY: **CAR**

MISCELLANEOUS FRAMING DETAILS  
**D2.0**

SCALE: 1/4" = 1'-0" FOR 24x36 PAPER, NOT TO SCALE FOR 11x17 PAPER, OR AS NOTED

## JOIST DETAILS

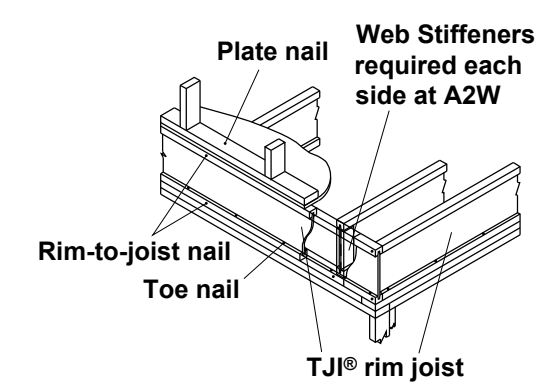

**A2 A2W** Must have 1/4" minimum joist bearing at ends. Attach rim joist per A3 detail.

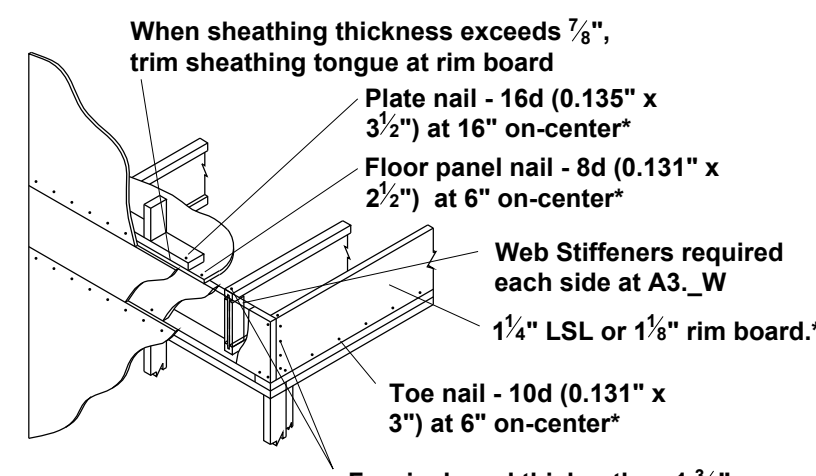

**A3 A3W** For rim board thicker than 1 3/4" - Attach Joist to rim board with one 10d (0.128"x3") nail. Top nail from joist into rim board. - Connect corner with four 10d (0.128"x3") nails. Toe nail from side of parallel closure into rim board

IRC 502-7 requires lateral restraint (blocking) at all intermediate supports in Seismic Design Categories D0, D1, and D2 to strengthen the floor diaphragm.

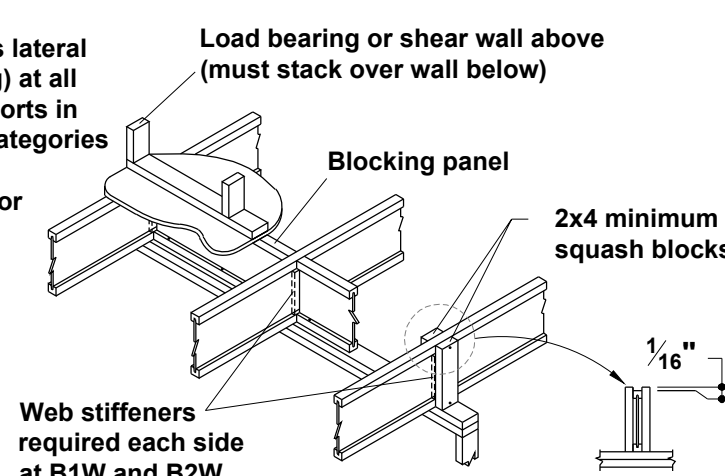

**B1 B1W B2 B2W** Blocking panels may be required with shear walls above or below - see detail B1

### INTERMEDIATE BEARING NO LOAD BEARING WALL ABOVE

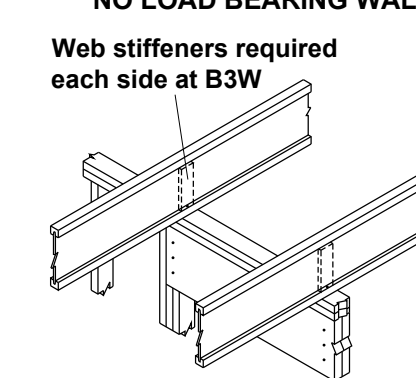

**B3 B3W** Blocking panels may be required with shear walls above or below (See detail B1)

Load bearing or shear wall above (must stack over wall below when present)

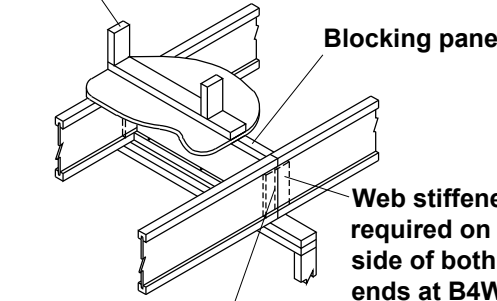

**B4 B4W** End of joists at centerline of support

Load from above

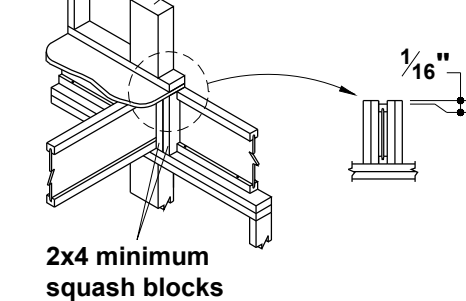

**C5** Use 2x4 minimum squash blocks to transfer load around joist

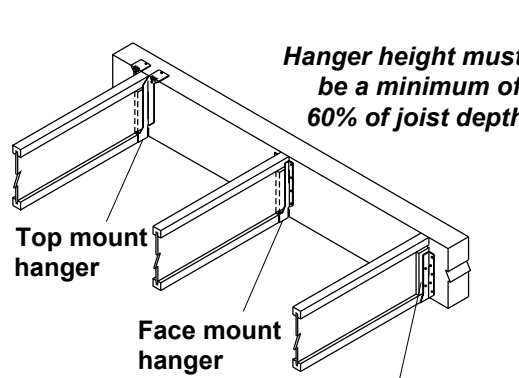

**H1** Web stiffeners required if sides of hanger do not laterally support at least 3/4" of joist top flange

## BEAM and COLUMN DETAILS

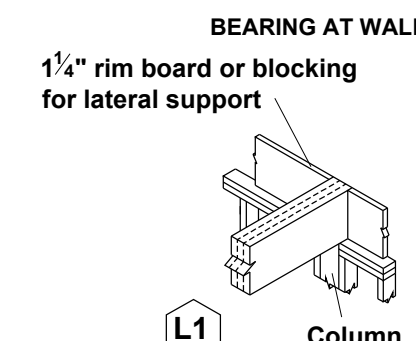

**L1** 1/4" rim board or blocking for lateral support

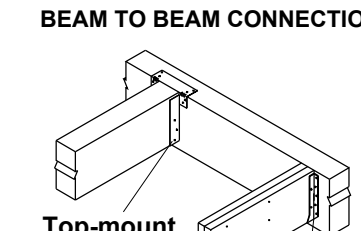

**L3** Top-mount hanger Face-mount hanger

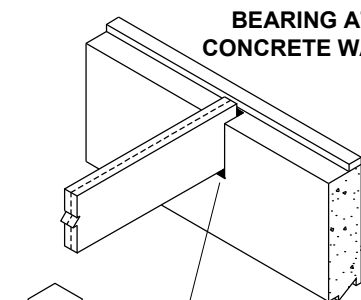

**L4** Protect untreated wood from direct contact with concrete

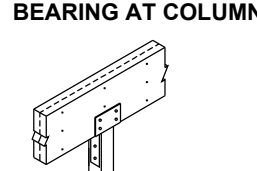

**L5** Verify column capacity and beam bearing length.

### FASTENING of FLOOR PANELS

Guidelines for Closest On-Center Spacing per Row

Nail Size	I-JOIST *		Rim Board	1 1/2" LSL	LVL	PSL
	110, 210, and 230 EQ.	360 and 560 EQ.	1 1/4" LSL	LSL or wider		
8d (0.131" x 2 1/2")	4"	3"	4"	3"	3"	3"
10d (0.148" x 3"), 12d (0.148" x 3 1/2")	4"	4"	4"	4"	4"	4"
16d (0.162" x 3 1/2")	6"	6"	6"(2)	6"(2)	8"	6"

(1) One row of fasteners permitted (two at abutting panel edges) for diaphragms. Stagger nails when using 4" on-center spacing and maintain 3/8" joist and panel edge distance. For other applications, multiple rows of fasteners are permitted if the rows are offset at least 1/2" and staggered.  
(2) Can be reduced to 4" on-center if nail penetration into the narrow edge is no more than 1 3/8" (to avoid splitting).

- Recommended nailing is 12" on-center in field and 6" on-center along panel edge. Fastening requirements on engineered drawings supersede recommendations listed above.
- Recommended use of a non-polyurethane subfloor adhesive on all contact points between panels and floor framing.
- Nailing rows must be offset at least 1/2" and staggered.
- 14 ga. staples may be substituted for 8d (0.113" x 2 1/2") nails if minimum penetration of 1" into the joist or rim board is achieved.
- Maximum spacing of nails is 18" on-center for joists.

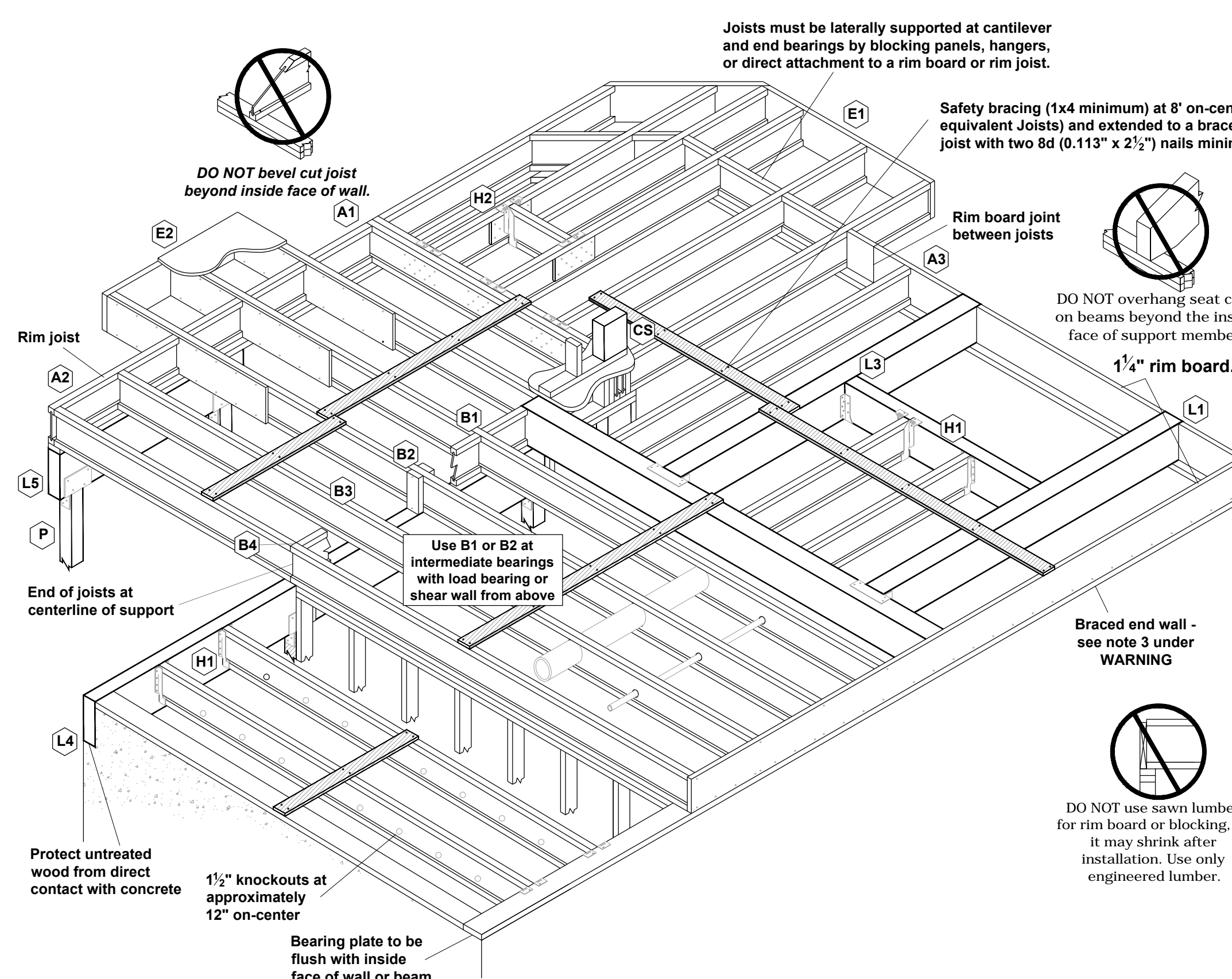

### FILLER and BACKER BLOCK SIZES

I-Joists	110 EQ. *		210 EQ. *		230 or 360 EQ. *			560 EQ. *		
	Depth	9 1/2" or 11 7/8"	9 1/2" or 11 7/8"	14" or 16"	9 1/2" or 11 7/8"	14" or 16"	18" or 20"	14 1/8"	14" or 16"	18" or 20"
Filler Block (1) (Detail H2)	2x6	2x8	2x6 + 3/8" sheathing	2x8 + 3/8" sheathing	2x6 + 1/2" sheathing	2x8 + 1/2" sheathing	2x12 + 1/2" sheathing	Two 2x6	Two 2x8	Two 2x12
Cantilever Filler (Detail E4)	2x6 long	2x10 long	2x6 + 3/8" sheathing 4'-0" long	2x10 + 3/8" sheathing 6'-0" long	2x6 + 1/2" sheathing 4'-0" long	2x10 + 1/2" sheathing 6'-0" long	Not applicable	Not applicable	Not applicable	Not applicable
Backer Block (1) (Detail F1 or H2)	5/8" or 3/4"	3/4" or 7/8"	3/4" or 7/8"	1" Net	2x6	2x8	2x12			

(1) If necessary, increase filler and backer block height for face mount hangers and maintain 1/8" gap at top of joist; see detail W. Filler and backer block lengths should accommodate required nailing without splitting (12" minimum for backer blocks and 24" minimum for filler blocks).

## INSTALLATION TIPS

Subfloor adhesive will improve floor performance, but may not be required.

Squash blocks and blocking panels carry stacked vertical loads (details B1 and B2). Packing out the web of a joist (with web stiffeners) is not a substitute for squash blocks or blocking panels.

When joists are doubled at non-load bearing parallel partitions, space joists apart the width of the wall for plumbing or HVAC.

Additional joist at plumbing drop (see detail).

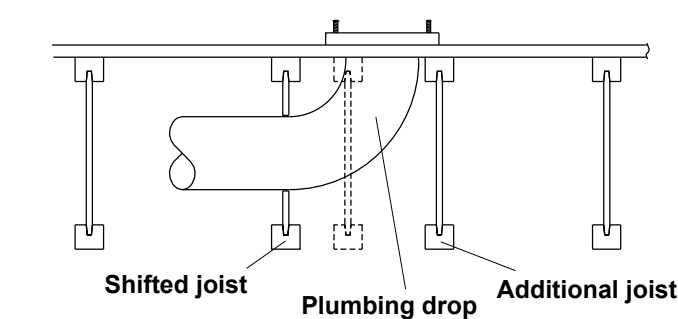

### \* I-JOIST EQUIVALENCY CHART

Depth	EQUIVALENT IN SPAN AND SPACING		
	Mfr & Series	Mfr & Series	Mfr & Series
9 1/2"	T.JI - 110	BCI 4500	
	T.JI - 210	BCI 5000	
	T.JI - 230	BCI 6000	EverEdge 20
11 7/8"	T.JI - 110	BCI 6500	
	T.JI - 210	BCI 5000	
	T.JI - 230	BCI 6000	EverEdge 20
	T.JI - 360	BCI 60'S	EverEdge 30
	T.JI - 560	BCI 90'S	EverEdge 50/60
	T.JI - 110	BCI 4500	
14"	T.JI - 210	BCI 5000	
	T.JI - 230	BCI 6000	EverEdge 20
	T.JI - 360	BCI 60'S	EverEdge 30
	T.JI - 560	BCI 90'S	EverEdge 50/60
	T.JI - 110	BCI 4500	
	T.JI - 210	BCI 5000	
16"	T.JI - 230	BCI 6000	EverEdge 20
	T.JI - 360	BCI 60'S	EverEdge 30
	T.JI - 560	BCI 90'S	EverEdge 50/60
	T.JI - 110	BCI 4500	

### JOIST NAILING REQUIREMENTS at BEARING

Joist to Bearing Plate

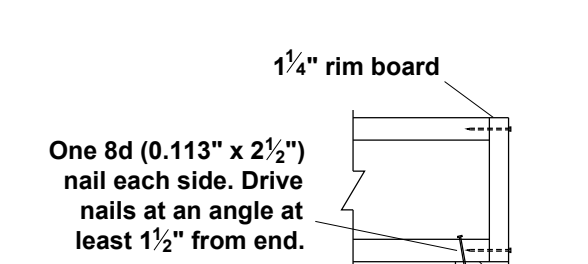

One 8d (0.113" x 2 1/2") nail each side. Drive nails at an angle at least 1 1/2" from end.

Squash Blocks to Joist (Load bearing wall above)

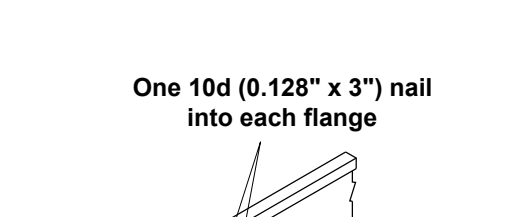

One 10d (0.128" x 3") nail into each flange. Also see detail B2

### RIM to JOIST

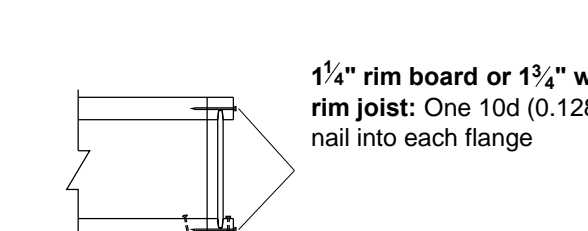

1/4" rim board or 1 3/4" wide rim joist: One 10d (0.128" x 3") nail into each flange

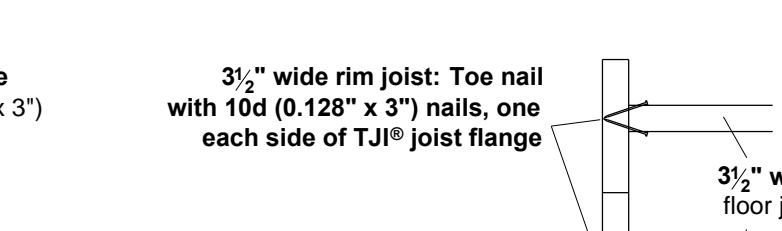

3 1/2" wide rim joist: Toe nail with 10d (0.128" x 3") nails, one each side of TJI® joist flange

### BEAM ATTACHMENT at BEARING

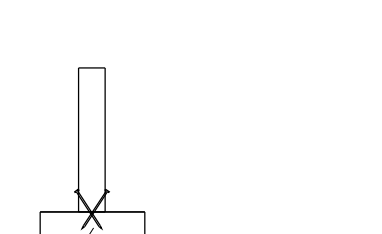

One 10d (0.128" x 3") nail each side of member at bearing, 1 1/2" minimum from end

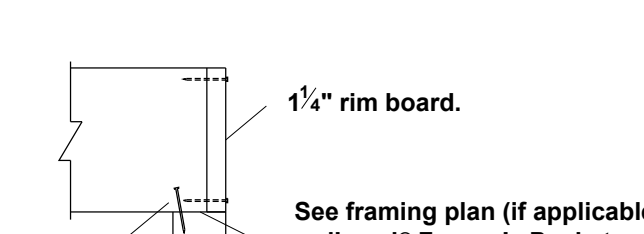

1/4" rim board. See framing plan (if applicable) or iLevel® Framers' Pocket Guide for minimum end and intermediate bearing lengths.



P-0961



JDS Consulting, LLC, 8600 TD JERSEY CT, RALEIGH, NC 27617, 919.480.4005  
 INFO@JDSCONSULTING.NET, WWW.JDSCONSULTING.NET  
 JDS Consulting, LLC IS NOT LIABLE FOR CHANGES MADE TO PLANS DUE TO CONSTRUCTION METHODS OR ANY CHANGES TO PLANS MADE IN THE FIELD. THE LOT NUMBER, PROPERTY OR ASA MASTER PLAN AS SPECIFIED ON TITLE SHEET, DIMENSIONS, SMALL GOVERN OVER SCALE, AND CODE SHALL GOVERN OVER DIMENSIONS ON DRAWINGS.

CLIENT: TRIANGLE BUILDING & PROPERTIES  
 PROJECT: CEDAR CREEK  
 LOCATION: NORTH CAROLINA

PROJECT NO.: 22900088

DATE: 03/14/2022 DRAWN BY: CAR

ENGINEERED JOIST DETAILS

D3.0

SCALE: 1/4" = 1'-0" FOR 24x36 PAPER, NOT TO SCALE FOR 11x17 PAPER, OR AS NOTED

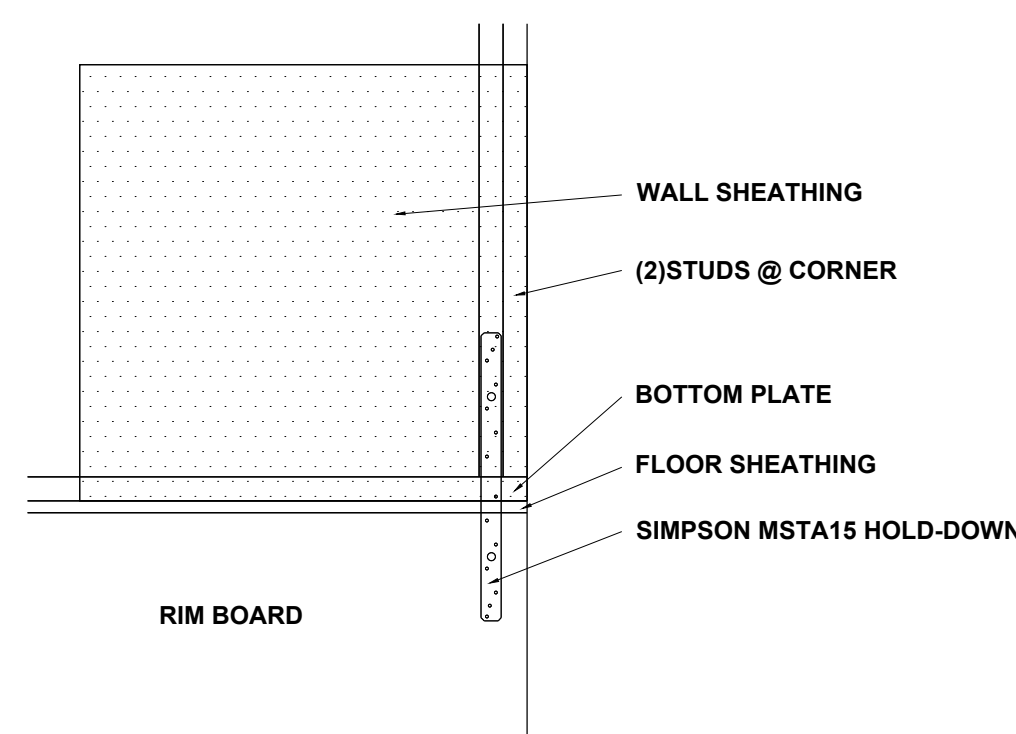
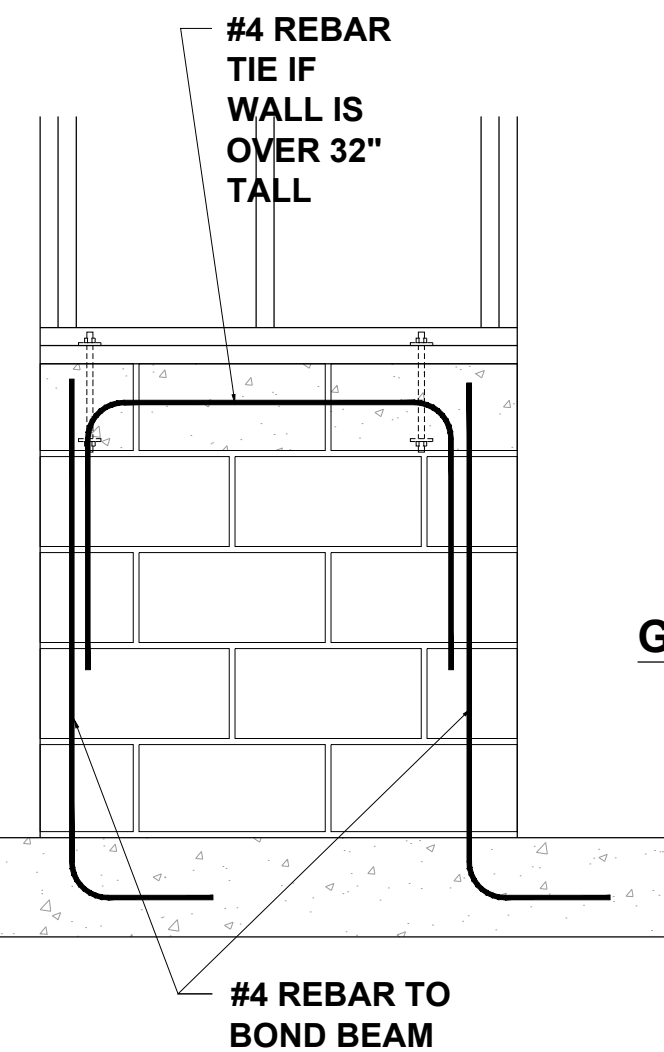
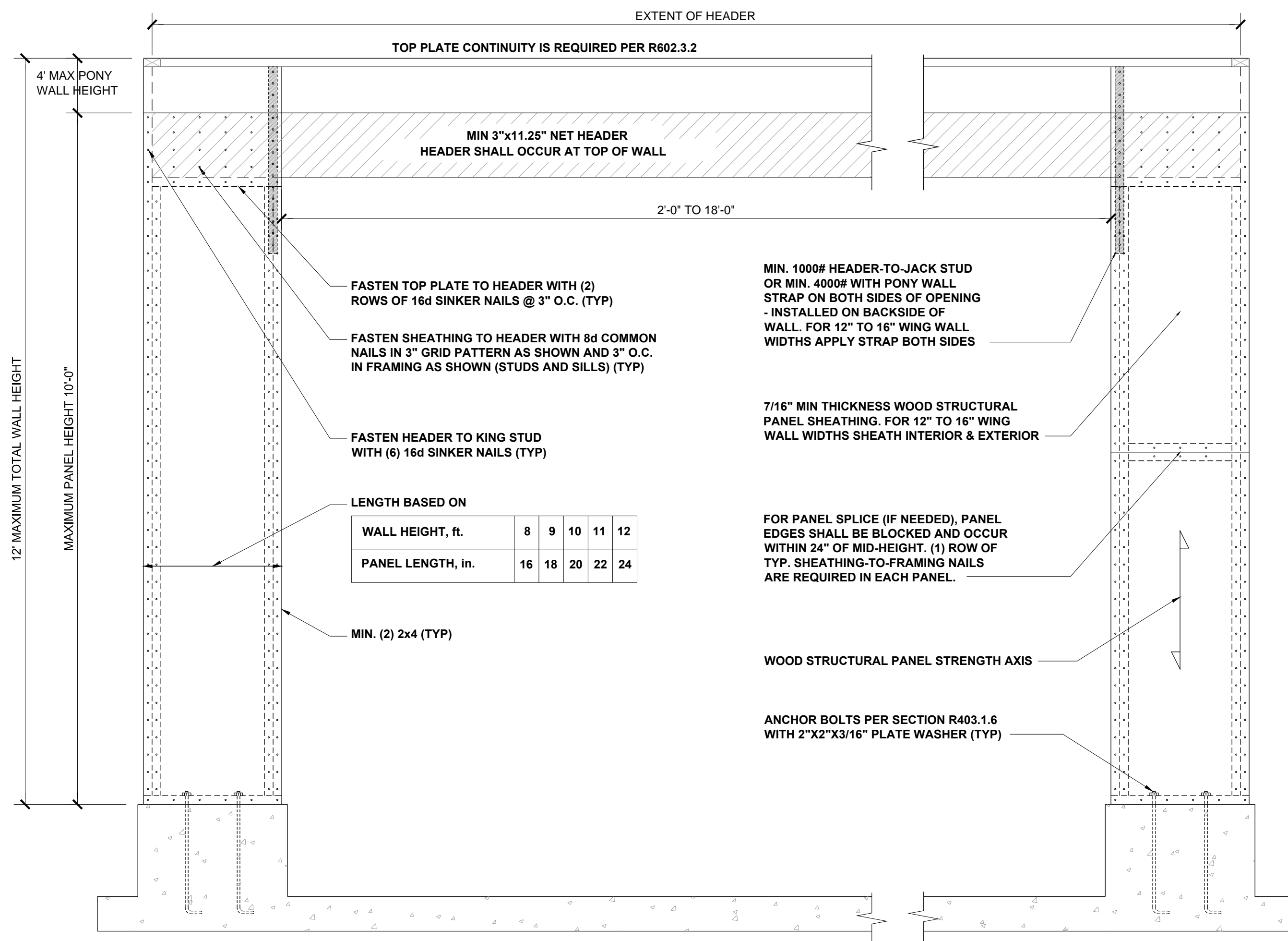

▶ SIMPSON MST15 HOLD DOWN CAPACITY OF 970 POUNDS PER ANCHOR WITH (12) 10d NAILS. STRAP TO BE LOCATED AT EDGE OF BRACED WALL PANEL.

**BRACED WALL HOLD-DOWN** 1" = 1'-0" **3**

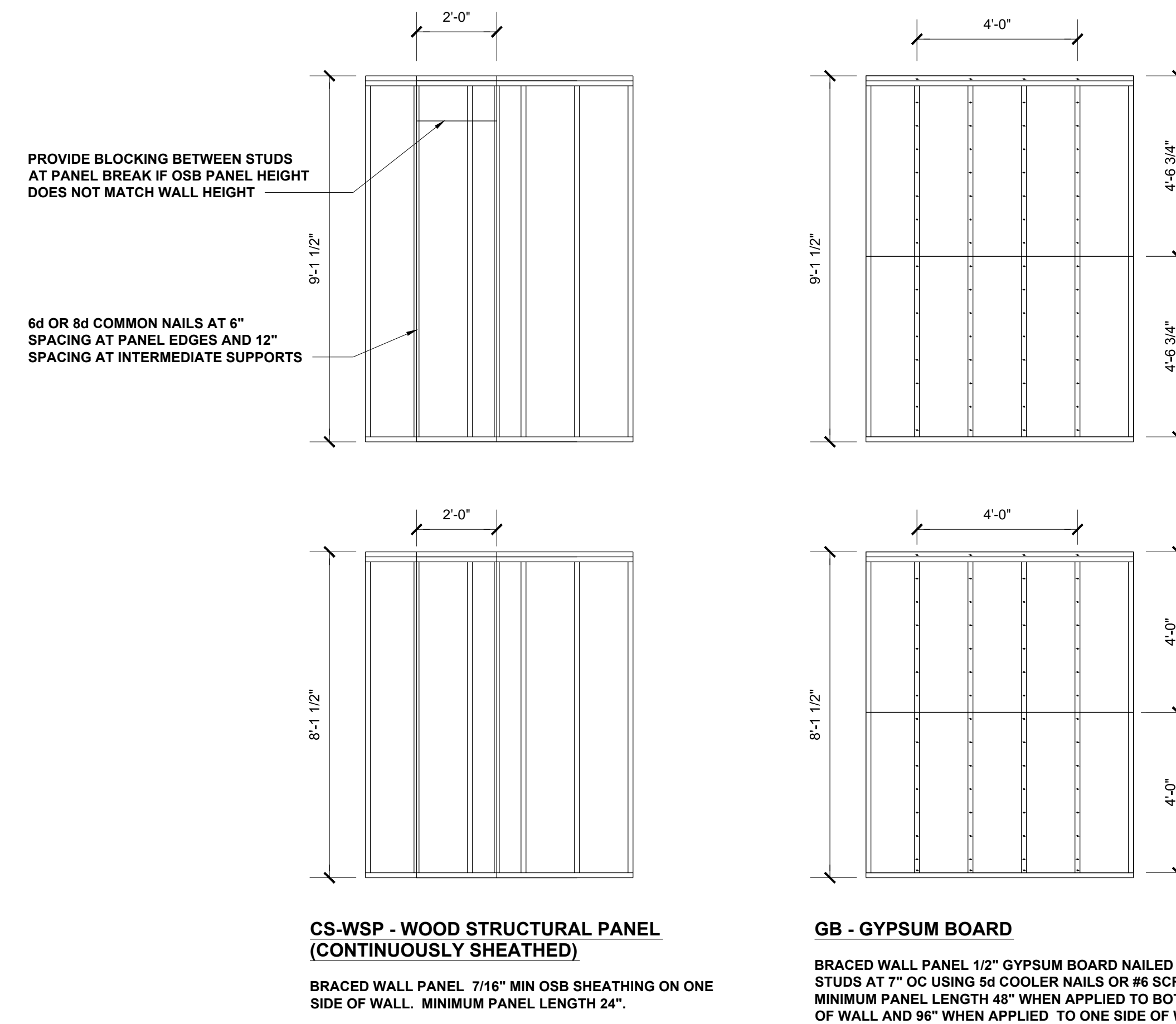

**HIGH-SPEED WIND ZONES**

FOR LOCATIONS OF 130 MPH OR MORE ULTIMATE DESIGN WIND SPEED (110 MPH OR MORE BASIC WIND SPEED IN VIRGINIA AND GEORGIA), WALLS SHALL BE BRACED PER THE LATEST ADOPTED EDITION OF THE AMERICAN SOCIETY OF CIVIL ENGINEERS PUBLICATION ASCE 7 OR STANDARD FOR RESIDENTIAL CONSTRUCTION IN HIGH-WIND REGIONS (ICC 600).

**METHOD PF: PF PANEL CONSTRUCTION** 3/4" = 1'-0" **1**

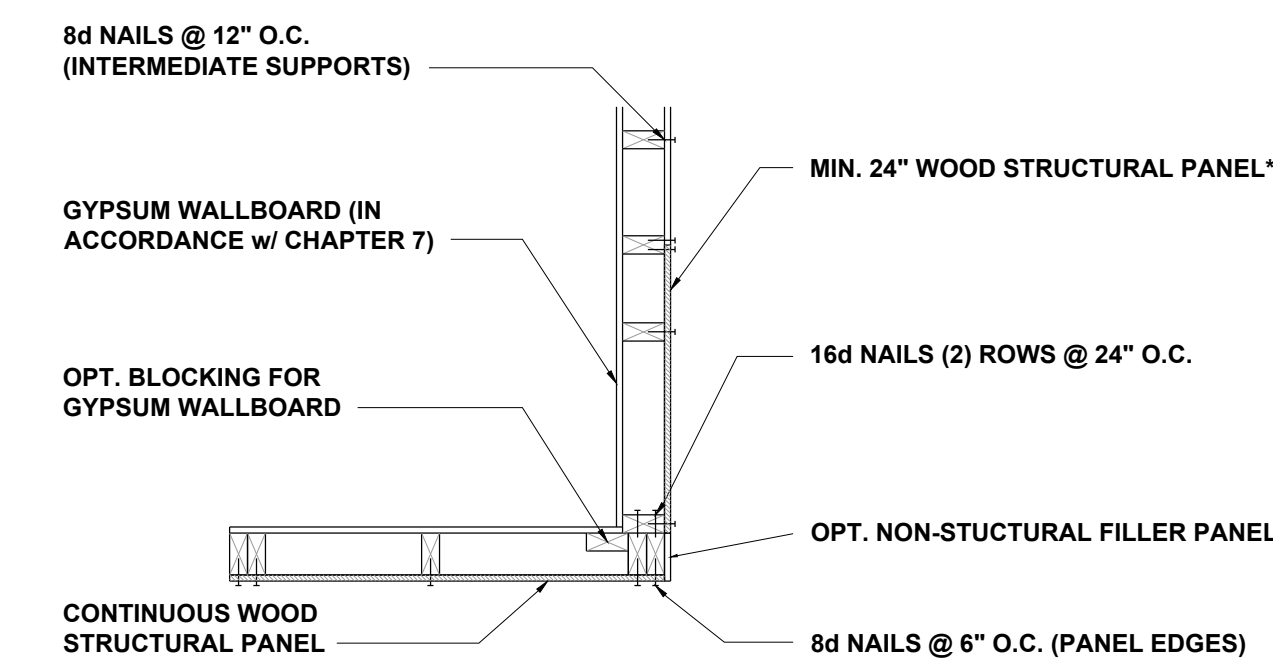

**A) GARAGE DOOR CORNER**

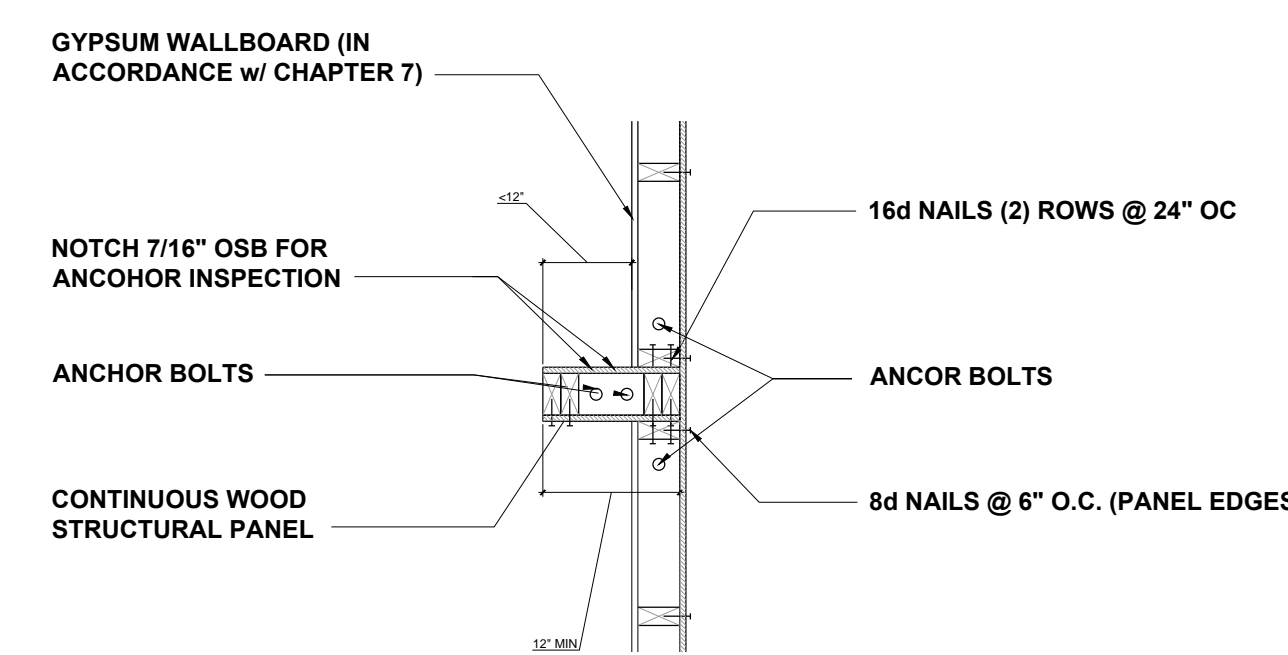

**B) GARAGE T-WALL PORTAL FRAMING 16"-12"**

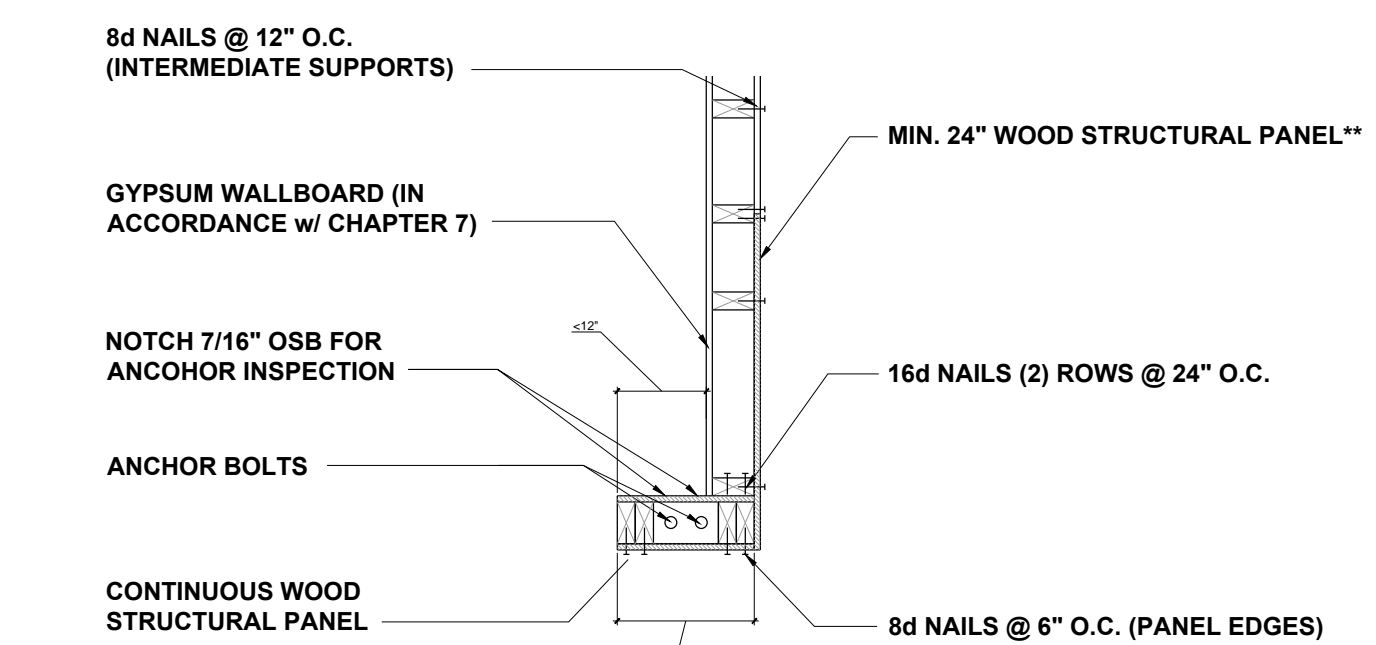

**C) GARAGE DOOR CORNER PORTAL FRAMING 16"-12"**

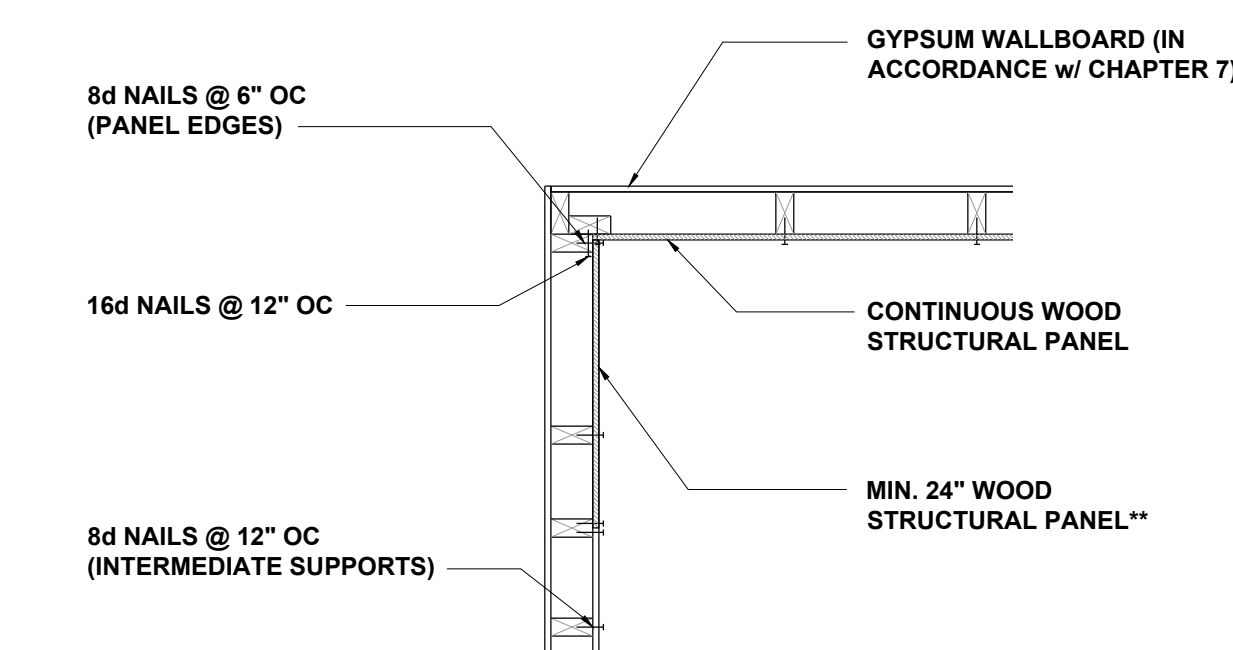

**D) ALTERNATE INSIDE CORNER DETAIL**

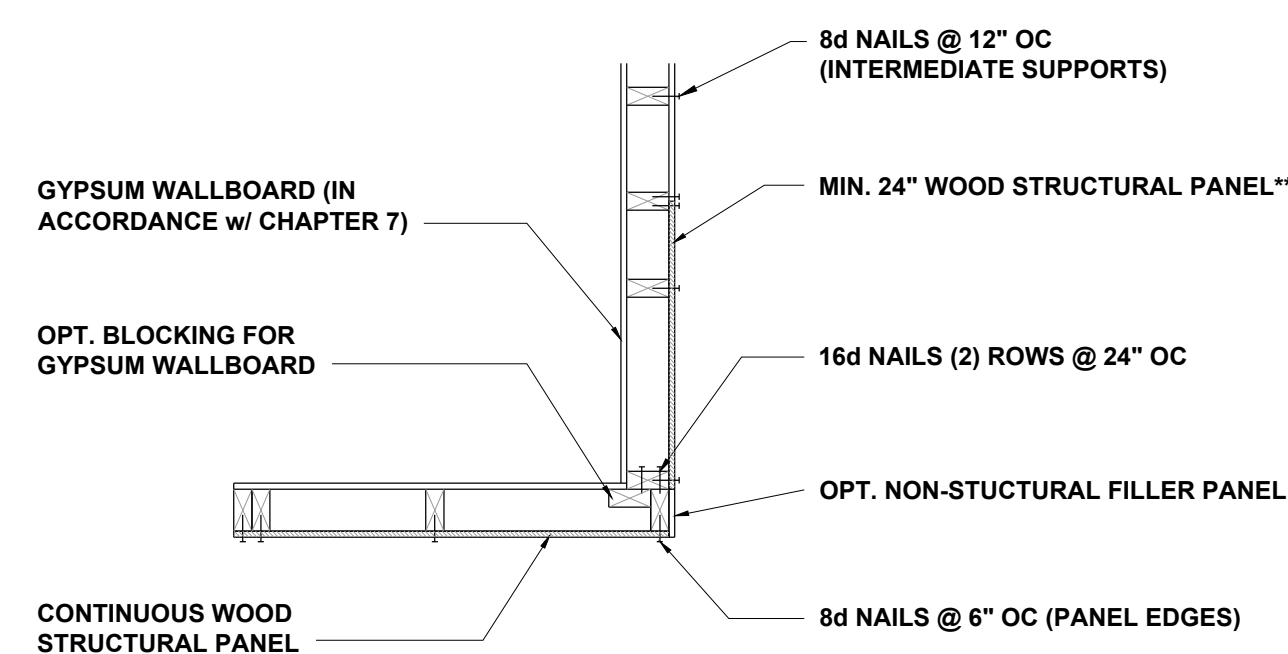

**E) ALTERNATE OUTSIDE CORNER DETAIL**

\*\* IN LIEU OF THE CORNER RETURN, A HOLD-DOWN DEVICE WITH A MINIMUM UPLIFT DESIGN VALUE OF 800# SHALL BE FASTENED TO THE CORNER STUD AND TO THE FOUNDATION OR FRAMING BELOW.

**BRACING METHODS** 3/8" = 1'-0" **2**

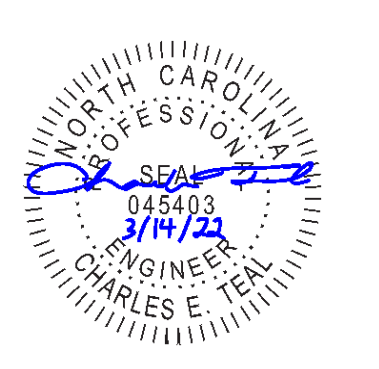

**JDS Consulting**  
ENGINEERING • DESIGN • ENERGY

JDS Consulting LLC, 8600 TP JERSEY CT, RALEIGH, NC 27617 919.480.1005  
INFO@JDSCONSULTING.NET WWW.JDSCONSULTING.NET

JDS Consulting LLC IS NOT LIABLE FOR CHANGES MADE TO PLANS DUE TO CONSTRUCTION METHODS OR ANY CHANGES TO PLANS MADE IN THE FIELD. THE CONTRACTOR SHALL BE RESPONSIBLE FOR VERIFYING ALL DIMENSIONS, THE LOT NUMBER, PROPERTY OR ASA MASTER PLAN AS SPECIFIED ON TITLE SHEET. DIMENSIONS SHALL GOVERN OVER SCALE, AND CODE SHALL GOVERN OVER DIMENSIONS ON DRAWINGS.

CLIENT: **TRIANGLE BUILDING & PROPERTIES**

PROJECT: **CEDAR CREEK**

LOCATION: **NORTH CAROLINA**

SCALE: 1/4" = 1'-0" FOR 24x36 PAPER, NOT TO SCALE FOR 11x17 PAPER, OR AS NOTED

PROJECT NO.: **22900088**

DATE: **03/14/2022** DRAWN BY: **CAR**

WALL BRACING DETAILS

**D4.0**

**CORNER FRAMING FOR CONTINUOUS SHEATHING** 3/4" = 1'-0" **4**

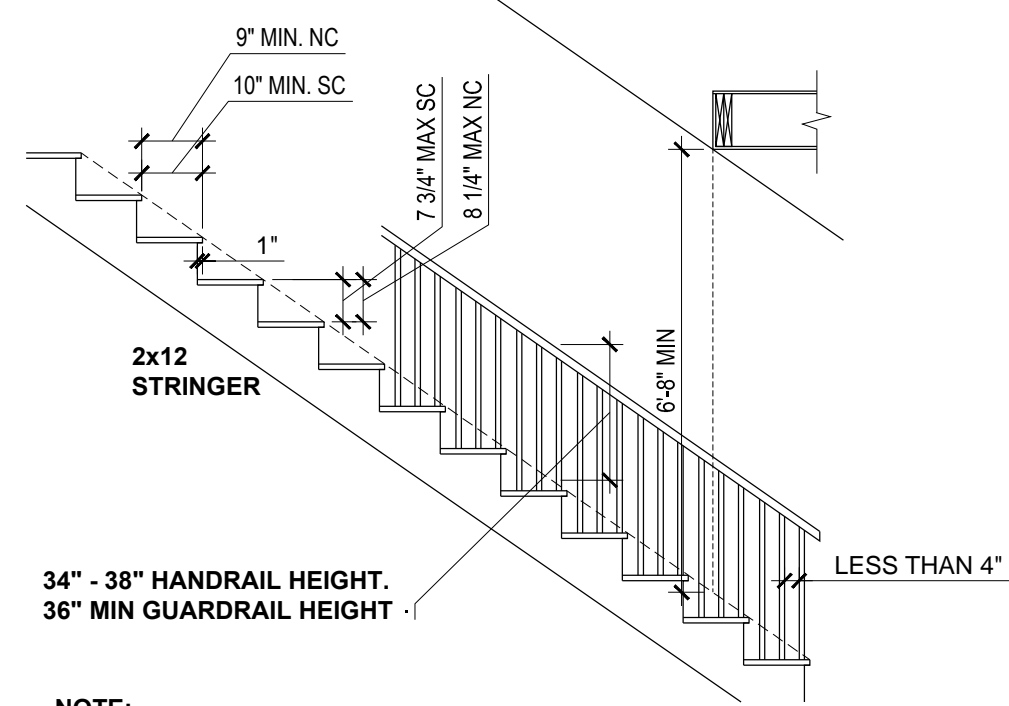

NOTE: EACH TREAD AND RISER MUST BE UNIFORM, WITH NO MORE THAN 3/8\"/>

**TYPICAL STAIR REQUIREMENTS** 3/8" = 1'-0" **1**

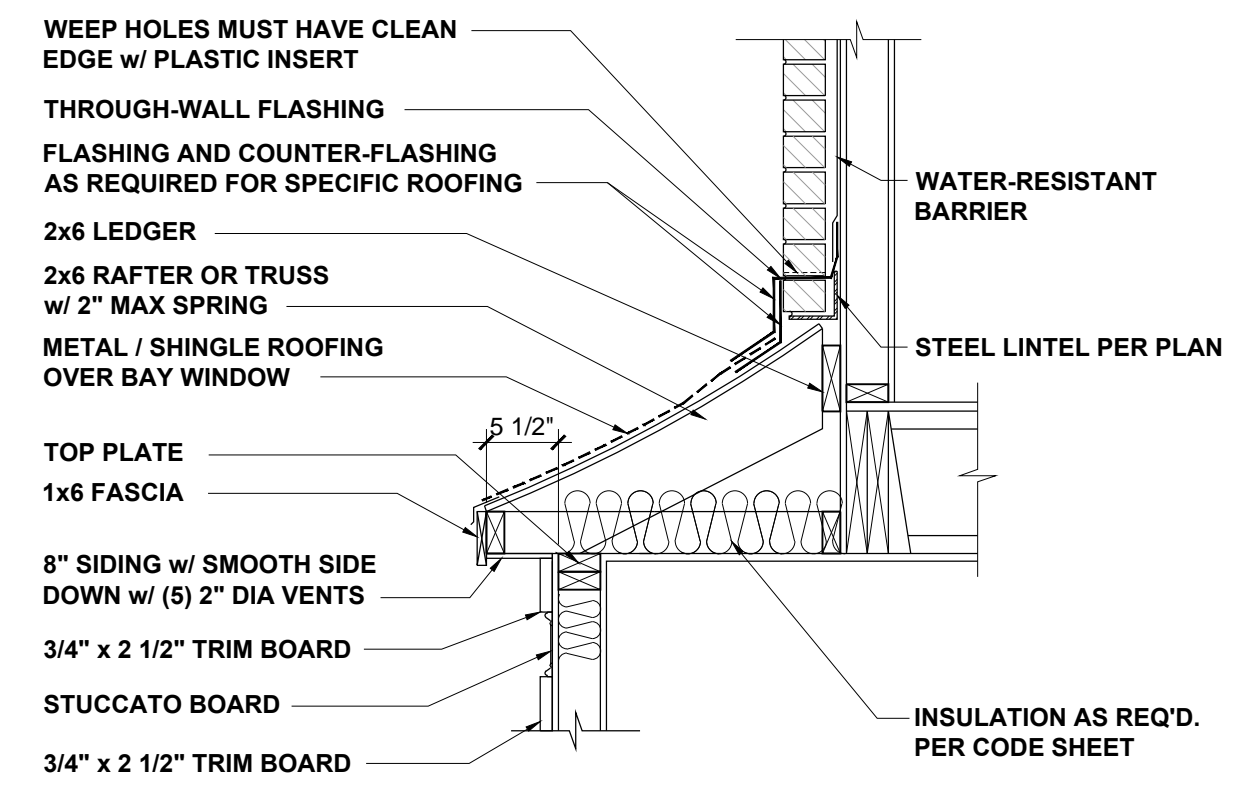

**BAY ROOF** 3/4" = 1'-0" **2**

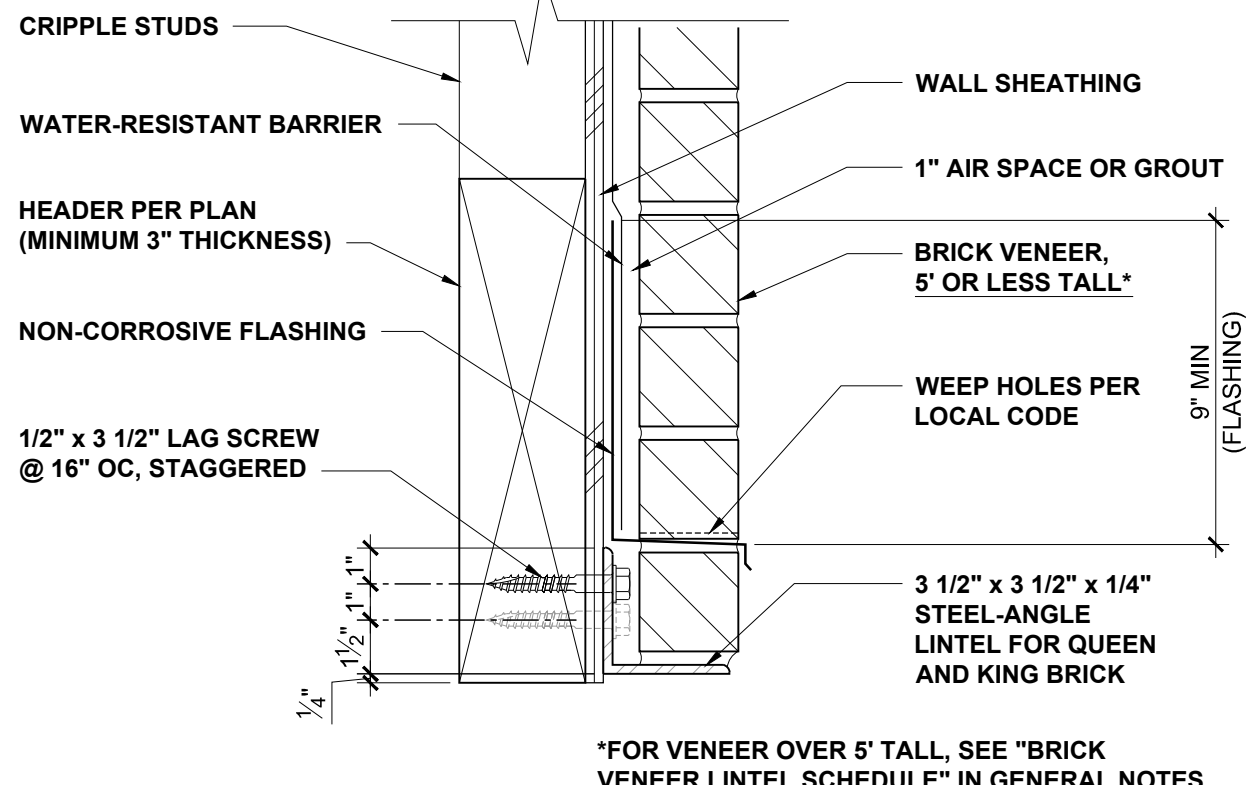

**ALTERNATE LINTEL AT WIDE OPENING** NTS **3**

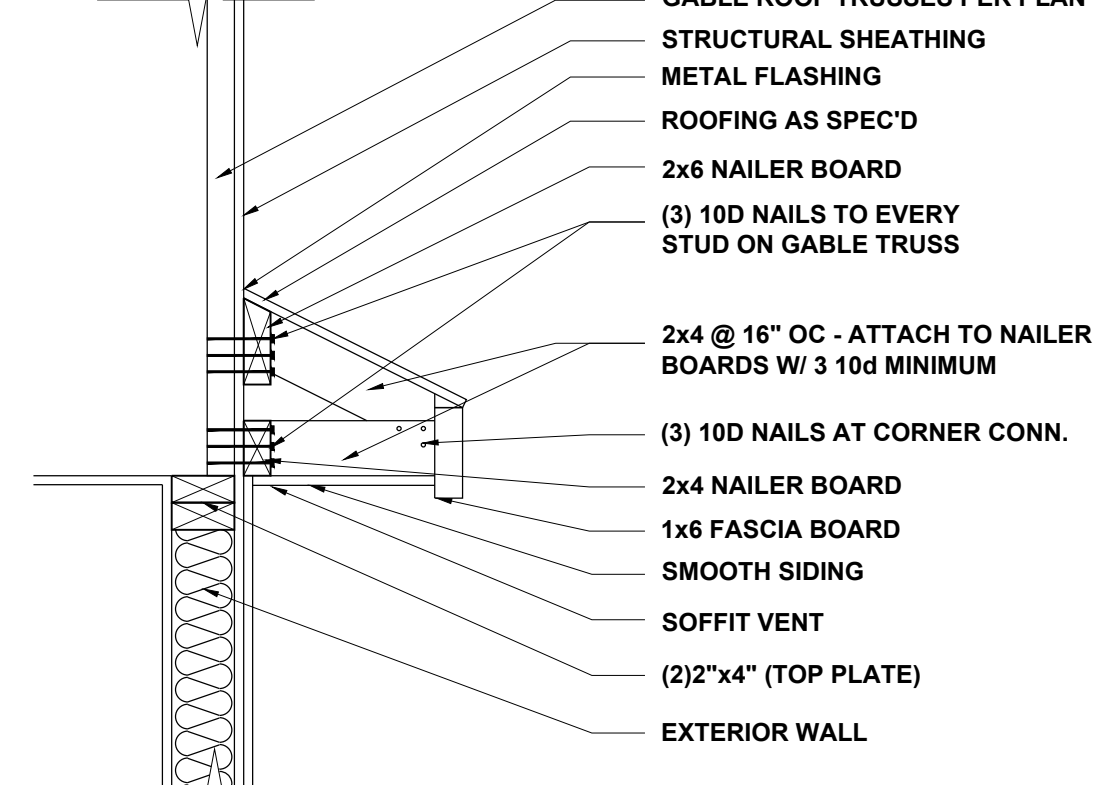

**GABLE ROOF RETURN** NTS **4**

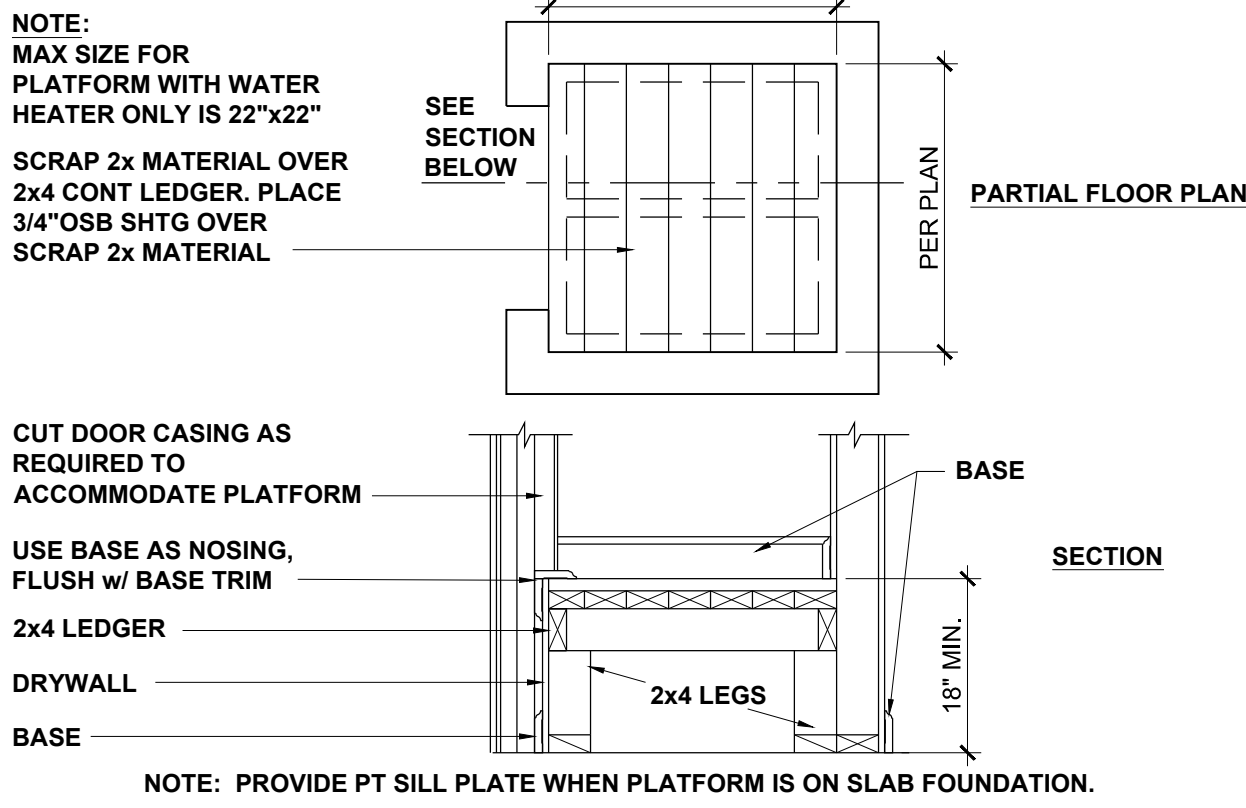

**HVAC / WATER HEATER CLOSET** 3/4" = 1'-0" **5**

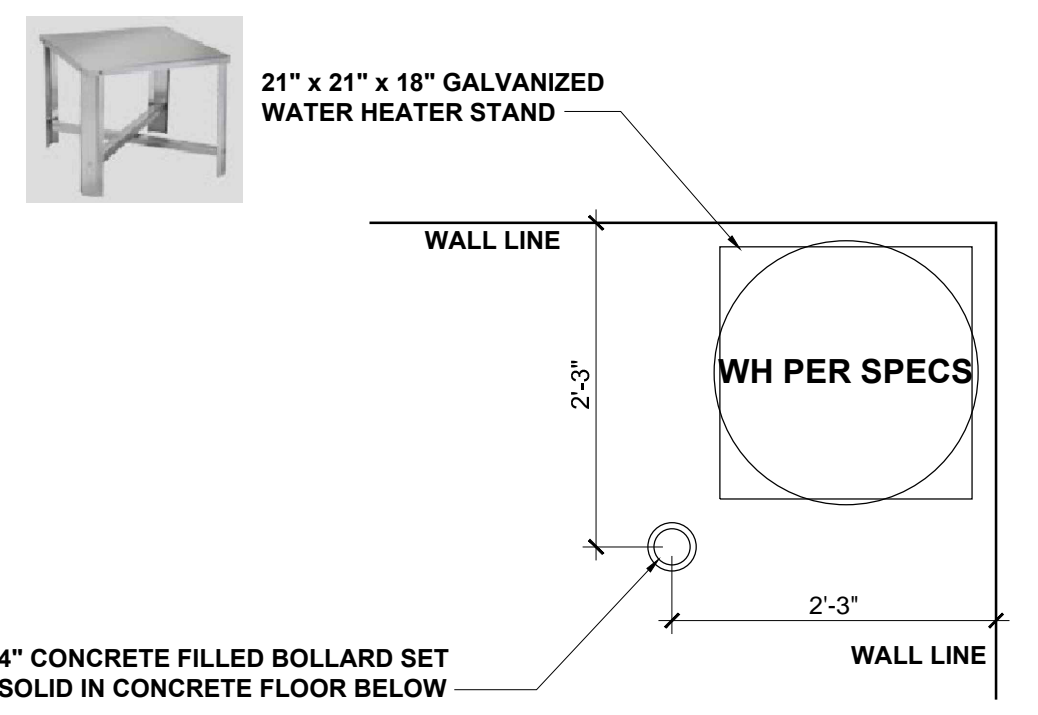

**WATER HTR PLATFORM IN GARAGE** 3/4" = 1'-0" **6**

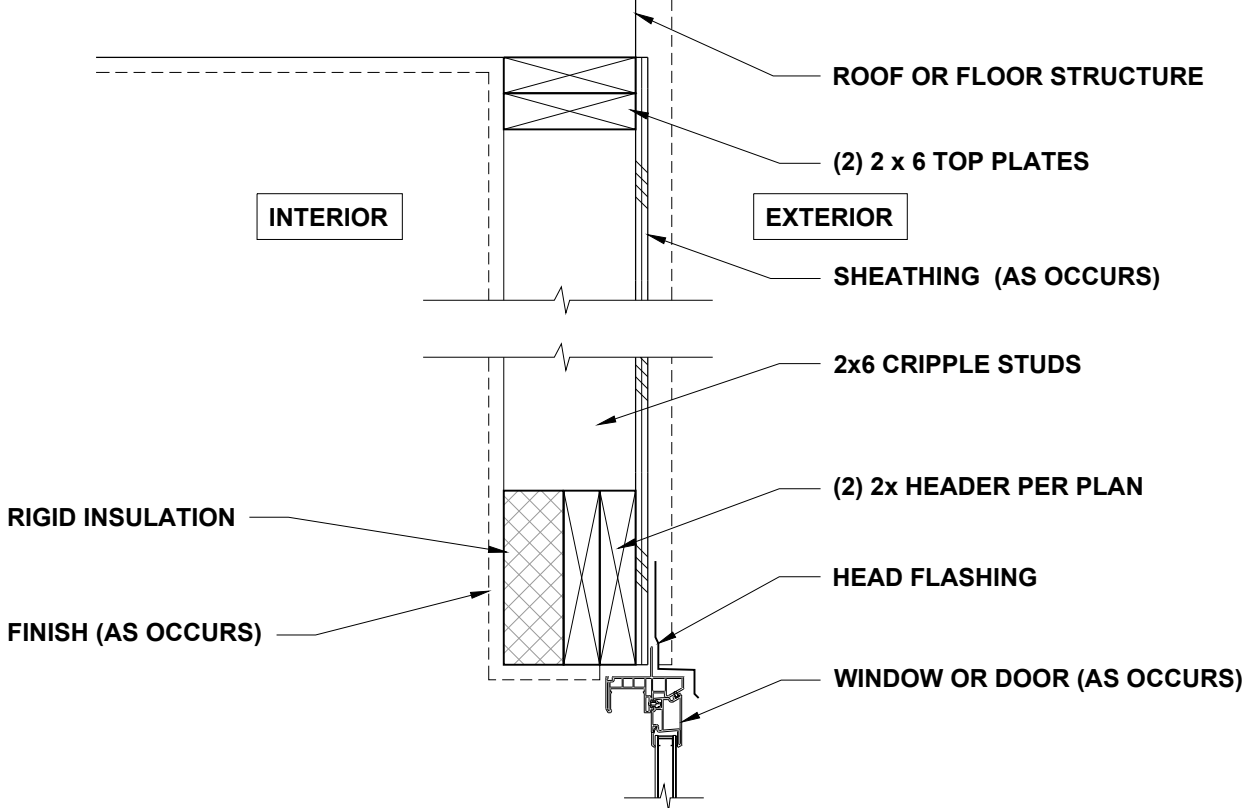

**HEADER WITH INSULATION** 1 1/2" = 1'-0" **7**

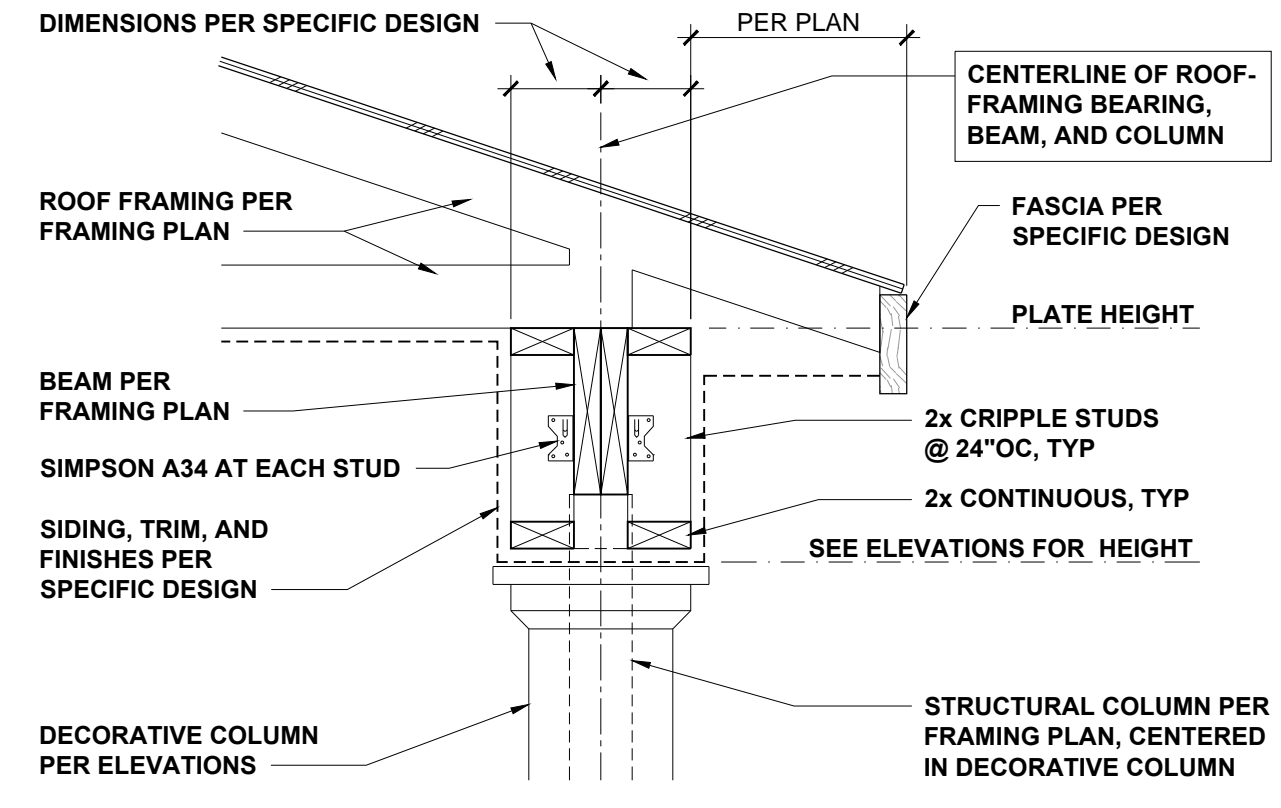

**COVERED PORCH EAVES** NTS **8**

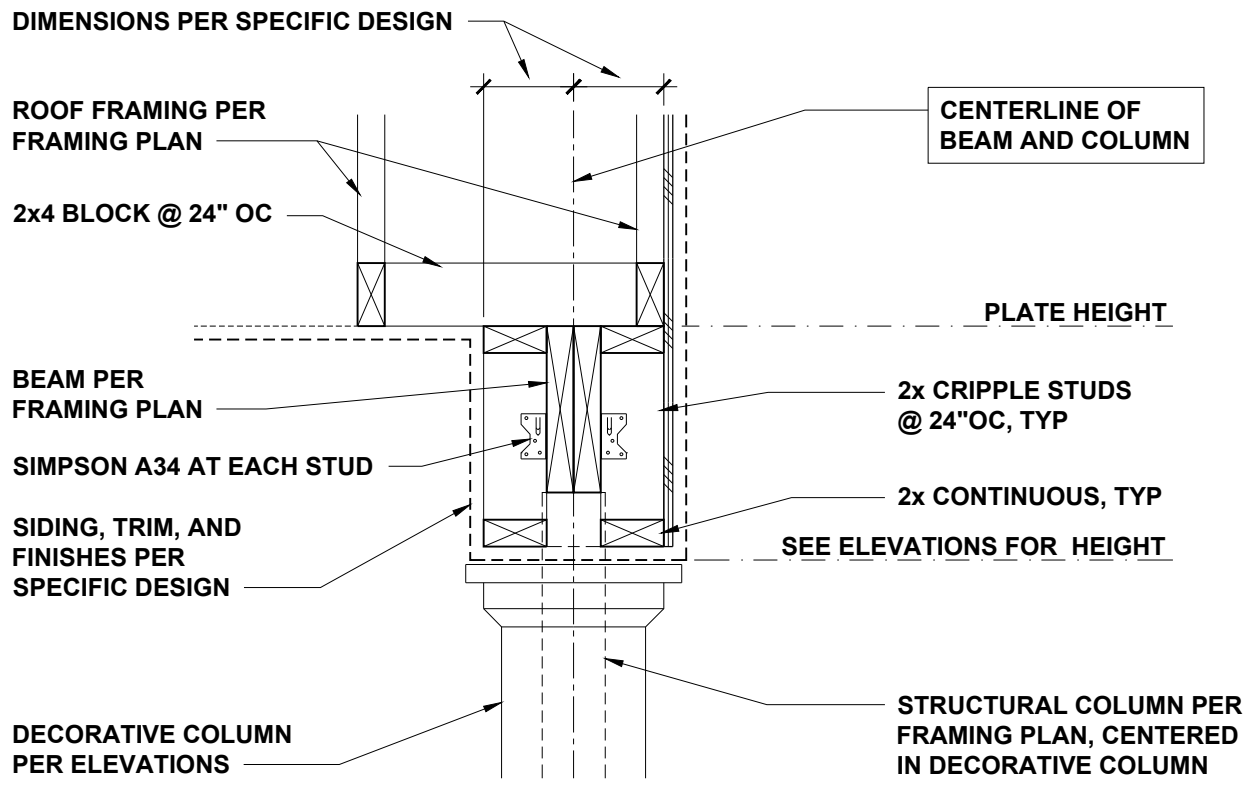

**COVERED PORCH RAKE** NTS **9**

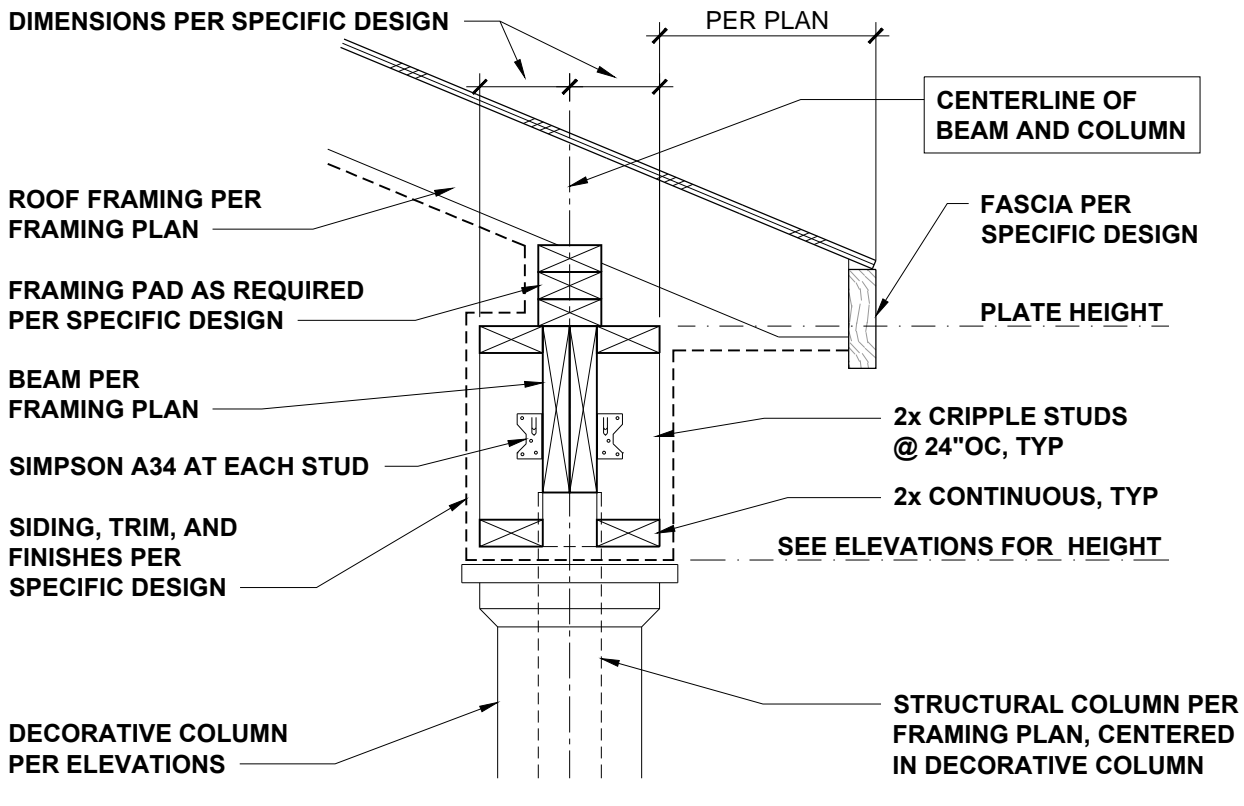

**COVERED PORCH WITH SLOPING CEILING** NTS **10**

**JDS Consulting**  
ENGINEERING • DESIGN • ENERGY  
JDS Consulting, LLC, 1600 TP JERSEY CT, RALEIGH, NC 27617-9010-1005  
INFO@JDSCONSULTING.NET WWW.JDSCONSULTING.NET

CLIENT: **TRIANGLE BUILDING & PROPERTIES**  
PROJECT: **CEDAR CREEK**  
LOCATION: **NORTH CAROLINA**

PROJECT NO.: **22900088**  
DATE: **03/14/2022** DRAWN BY: **CAR**  
MISCELLANEOUS FRAMING DETAILS  
**D5.0**

SCALE: 1/4" = 1'-0" FOR 24x36 PAPER, NOT TO SCALE FOR 11x17 PAPER, OR AS NOTED