



ROOF & FLOOR TRUSSES & BEAMS

Reilly Road Industrial Park
Fayetteville, N.C. 28309
Phone: (910) 864-8787
Fax: (910) 864-4444

Bearing reactions less than or equal to 3000# are deemed to comply with the prescriptive Code requirements. The contractor shall refer to the attached Tables (derived from the prescriptive Code requirements) to determine the minimum foundation size and number of wood studs required to support reactions greater than 3000# but not greater than 15000#. A registered design professional shall be retained to design the support system for any reaction that exceeds those specified in the attached Tables. A registered design professional shall be retained to design the support system for all reactions that exceed 15000#.

Signature David Landry

LOAD CHART FOR JACK STUDS

(BASED ON TABLES MODEL: S 103)

EVENING (IN) (SP-75)	NUMBER OF JACK STUDS REQUIRED PER EACH END OF HEADERS/BEAMS	REQ'D STUDS PER FOOTING	
		REQ'D STUDS PER FOOTING	REQ'D STUDS PER FOOTING
1700	1	2550	3400
2400	2	5100	6800
3100	3	7650	10200
3800	4	10200	13600
4500	5	12750	17000
5200	6	15300	
5900	7		
6600	8		
7300	9		

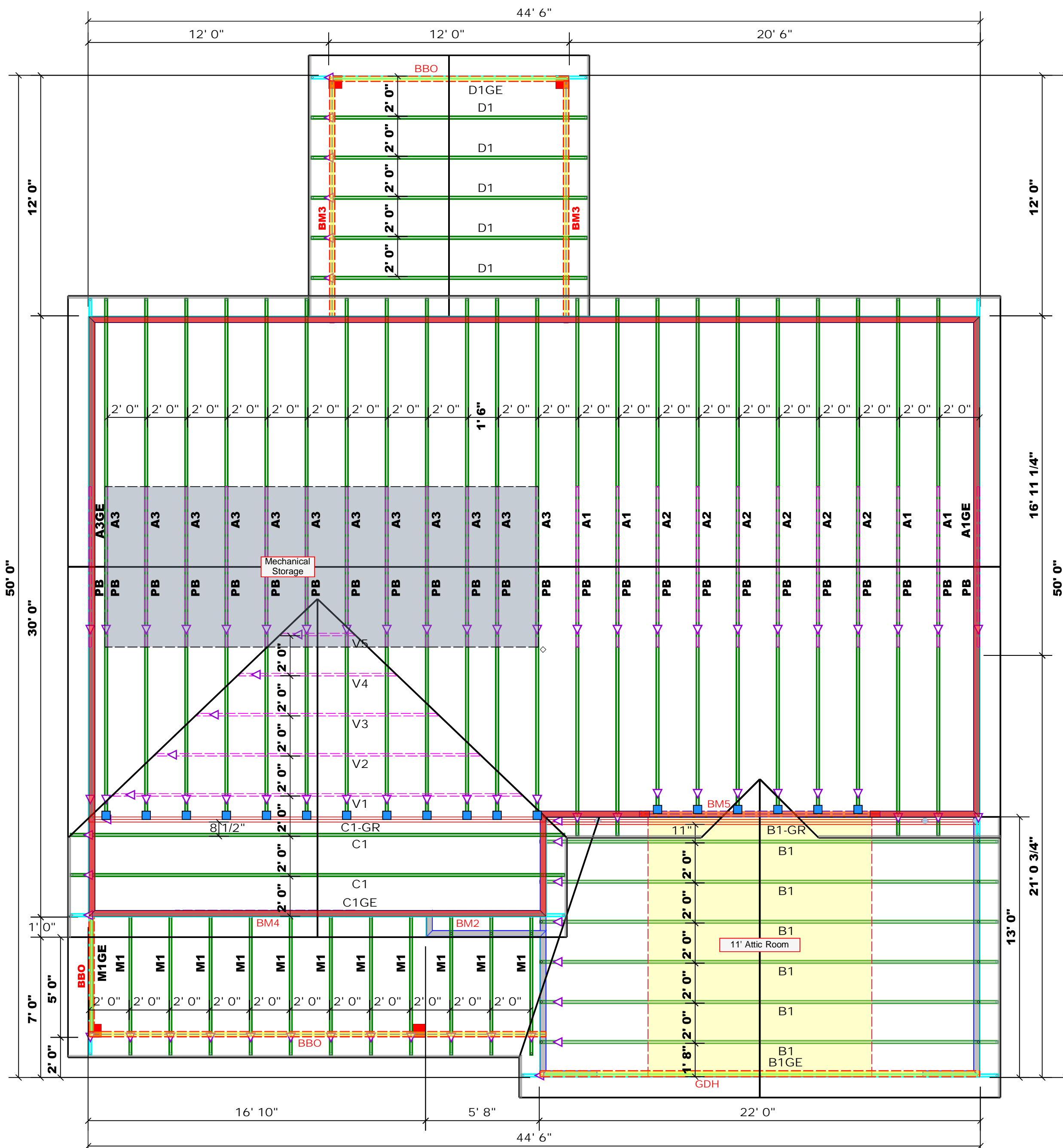

Products					
PlotID	Length	Product	Piles	Net Qty	Fab Type
BM5	12' 0"	1-3/4"x 11-7/8" LVL Kerto-S	2	2	FF

Hatch Legend	
	Padded HVAC
	Second Floor Walls

Roof Area = 2768.4 sq.ft.
Ridge Line = 92.31 ft.
Hip Line = 0 ft.
Horiz. OH = 137.81 ft.
Raked OH = 181.25 ft.
Decking = 95 sheets

1 Truss Placement Plan
Scale: 1/4"=1'

Dimension Notes
1. All exterior wall to wall dimensions are to face of sheathing unless noted otherwise
2. All interior wall dimensions are to face of frame wall unless noted otherwise
3. All exterior wall to truss dimensions are to face of frame wall unless noted otherwise

All Walls Shown Are Considered Load Bearing

Connector Information				Nail Information		
Sym	Product	Manuf	Qty	Supported Member	Header	Truss
	HUS26	USP	18	Varies	16d/3-1/2"	16d/3-1/2"

BUILDER	Benjamin Stout Real Estate	COUNTY	Fayetteville / Cumberland
JOB NAME	Lot 5 Cypress Road	ADDRESS	Cypress Road
PLAN	The Ashville	MODEL	Roof
SEAL DATE	N/A	DATE REV.	03/10/22
QUOTE #		DRAWN BY	David Landry
JOB #	J0322-1269	SALESMAN	Marshall Naylor

THIS IS A TRUSS PLACEMENT DIAGRAM ONLY. These trusses are designed as individual building components to be incorporated into the building design at the specification of the building designer. See individual design sheets for each truss design identified on the placement drawing. The building designer is responsible for temporary and permanent bracing of the roof and floor system and for the overall structure. The design of the truss support structure including headers, beams, walls, and columns is the responsibility of the building designer. For general guidance regarding bracing, consult BCS-81 and BCS-83 provided with the truss delivery package or online @ sbcindustry.com



RE: J0322-1269
Lot 5 Cypress Road

Trenco
818 Soundside Rd
Edenton, NC 27932

Site Information:

Customer: Benjamin Stout Real Estate Project Name: J0322-1269
Lot/Block: 5 Model: Williams
Address: Cypress Road Subdivision: Cypress Road
City: Fayetteville State: NC

General Truss Engineering Criteria & Design Loads (Individual Truss Design Drawings Show Special Loading Conditions):

Design Code: IRC2015/TPI2014 Design Program: MiTek 20/20 8.4
Wind Code: ASCE 7-10 Wind Speed: 130 mph
Roof Load: 40.0 psf Floor Load: N/A psf

This package includes 21 individual, dated Truss Design Drawings and 0 Additional Drawings.

No.	Seal#	Truss Name	Date	No.	Seal#	Truss Name	Date
1	E16391025	A1	11/9/2021	21	E16391045	V5	11/9/2021
2	E16391026	A1GE	11/9/2021				
3	E16391027	A2	11/9/2021				
4	E16391028	A3	11/9/2021				
5	E16391029	A3GE	11/9/2021				
6	E16391030	B1	11/9/2021				
7	E16391031	B1-GR	11/9/2021				
8	E16391032	B1GE	11/9/2021				
9	E16391033	C1	11/9/2021				
10	E16391034	C1-GR	11/9/2021				
11	E16391035	C1GE	11/9/2021				
12	E16391036	D1	11/9/2021				
13	E16391037	D1GE	11/9/2021				
14	E16391038	M1	11/9/2021				
15	E16391039	M1GE	11/9/2021				
16	E16391040	PB	11/9/2021				
17	E16391041	V1	11/9/2021				
18	E16391042	V2	11/9/2021				
19	E16391043	V3	11/9/2021				
20	E16391044	V4	11/9/2021				

The truss drawing(s) referenced above have been prepared by Truss Engineering Co. under my direct supervision based on the parameters provided by Comtech, Inc - Fayetteville.

Truss Design Engineer's Name: Gilbert, Eric

My license renewal date for the state of North Carolina is December 31, 2022.

North Carolina COA: C-0844

IMPORTANT NOTE: The seal on these truss component designs is a certification that the engineer named is licensed in the jurisdiction(s) identified and that the designs comply with ANSI/TPI 1. These designs are based upon parameters shown (e.g., loads, supports, dimensions, shapes and design codes), which were given to TRENCO. Any project specific information included is for TRENCO customers file reference purpose only, and was not taken into account in the preparation of these designs. TRENCO has not independently verified the applicability of the design parameters or the designs for any particular building. Before use, the building designer should verify applicability of design parameters and properly incorporate these designs into the overall building design per ANSI/TPI 1, Chapter 2.



November 09, 2021

Job J0322-1269	Truss A1	Truss Type PIGGYBACK BASE	Qty 4	Ply 1	Lot 5 Cypress Road Job Reference (optional)	E16391025
-------------------	-------------	------------------------------	----------	----------	--	-----------

Comtech, Inc. Fayetteville, NC - 28314, 8.430 s Aug 16 2021 MiTek Industries, Inc. Mon Nov 8 13:12:28 2021 Page 1
 ID:J6aSr?qB6etazEy6hKRSkZzPTZ_-MqpdUM7EoTIN24GPTwDRWQD5Mu8NN4J809sp6yLENX

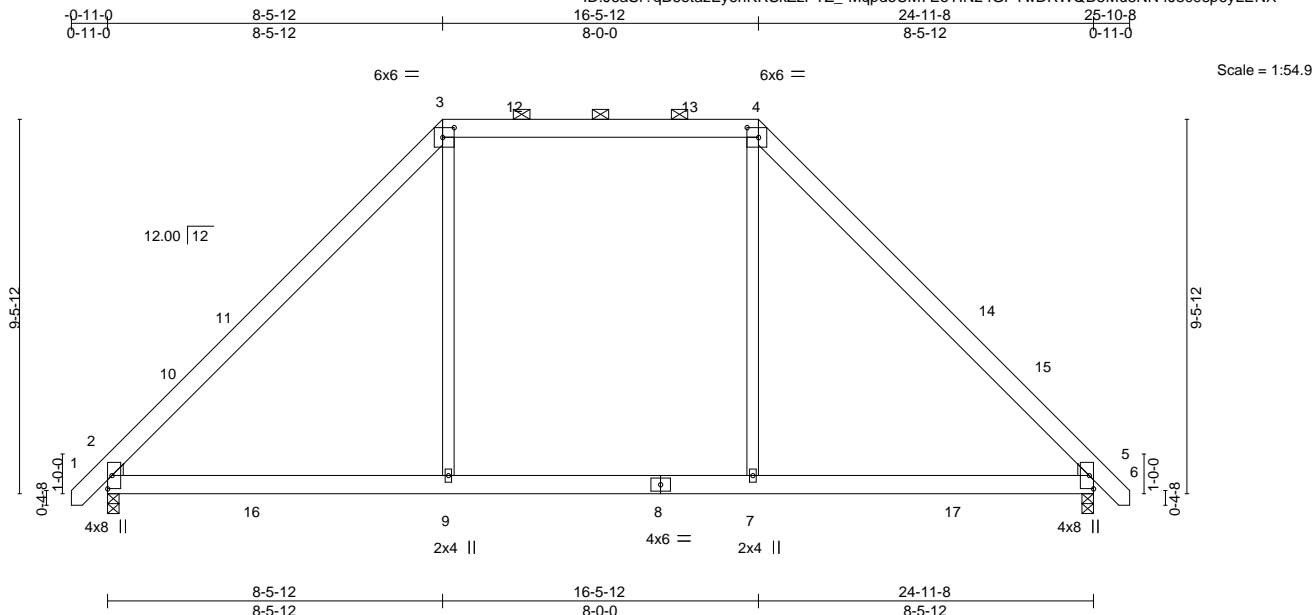

Plate Offsets (X,Y)-- [3:0-3-8,0-3-0], [4:0-3-8,0-3-0]

LOADING (psf)	SPACING- 2-0-0	CSI.	DEFL. in (loc) l/defl L/d	PLATES	GRIP
TCLL 20.0	Plate Grip DOL 1.15	TC 0.43	Vert(LL) -0.15 5-7 >999 360	MT20	244/190
TCDL 10.0	Lumber DOL 1.15	BC 0.46	Vert(CT) -0.20 5-7 >999 240		
BCLL 0.0 *	Rep Stress Incr YES	WB 0.15	Horz(CT) 0.02 5 n/a n/a		
BCDL 10.0	Code IRC2015/TPI2014	Matrix-S	Wind(LL) 0.19 2-9 >999 240	Weight: 167 lb	FT = 20%

LUMBER-
 TOP CHORD 2x6 SP No.1
 BOT CHORD 2x6 SP No.1
 WEBS 2x4 SP No.2
 WEDGE
 Left: 2x4 SP No.2 , Right: 2x4 SP No.2

BRACING-
 TOP CHORD Structural wood sheathing directly applied or 6-0-0 oc purlins, except 2-0-0 oc purlins (6-0-0 max.): 3-4.
 BOT CHORD Rigid ceiling directly applied or 10-0-0 oc bracing.

REACTIONS. (size) 2=0-3-8, 5=0-3-8
 Max Horz 2=223(LC 11)
 Max Uplift 2=-35(LC 12), 5=-35(LC 13)
 Max Grav 2=1309(LC 2), 5=1309(LC 2)

FORCES. (lb) - Max. Comp./Max. Ten. - All forces 250 (lb) or less except when shown.
 TOP CHORD 2-3=-1465/308, 3-4=-908/350, 4-5=-1465/308
 BOT CHORD 2-9=-36/930, 7-9=-33/938, 5-7=-33/928
 WEBS 3-9=0/653, 4-7=0/653

- NOTES-**
- Unbalanced roof live loads have been considered for this design.
 - Wind: ASCE 7-10; Vult=130mph Vasd=103mph; TC DL=6.0psf; BCDL=6.0psf; h=15ft; Cat. II; Exp C; Enclosed; MWFRS (envelope) and C-C Exterior(2) -0-9-6 to 3-7-7, Interior(1) 3-7-7 to 8-5-12, Exterior(2) 8-5-12 to 14-8-7, Interior(1) 14-8-7 to 16-5-12, Exterior(2) 16-5-12 to 22-8-7, Interior(1) 22-8-7 to 25-8-14 zone; C-C for members and forces & MWFRS for reactions shown; Lumber DOL=1.60 plate grip DOL=1.60
 - Provide adequate drainage to prevent water ponding.
 - This truss has been designed for a 10.0 psf bottom chord live load nonconcurrent with any other live loads.
 - * This truss has been designed for a live load of 30.0psf on the bottom chord in all areas where a rectangle 3-6-0 tall by 2-0-0 wide will fit between the bottom chord and any other members, with BCDL = 10.0psf.
 - Provide mechanical connection (by others) of truss to bearing plate capable of withstanding 100 lb uplift at joint(s) 2, 5.
 - Graphical purlin representation does not depict the size or the orientation of the purlin along the top and/or bottom chord.



November 9, 2021

WARNING - Verify design parameters and READ NOTES ON THIS AND INCLUDED MITTEK REFERENCE PAGE MII-7473 rev. 5/19/2020 BEFORE USE.
 Design valid for use only with MiTek® connectors. This design is based only upon parameters shown, and is for an individual building component, not a truss system. Before use, the building designer must verify the applicability of design parameters and properly incorporate this design into the overall building design. Bracing indicated is to prevent buckling of individual truss web and/or chord members only. Additional temporary and permanent bracing is always required for stability and to prevent collapse with possible personal injury and property damage. For general guidance regarding the fabrication, storage, delivery, erection and bracing of trusses and truss systems, see **ANSI/TPI1 Quality Criteria, DSB-89 and BCSI Building Component Safety Information** available from Truss Plate Institute, 2670 Crain Highway, Suite 203 Waldorf, MD 20601



818 Soundside Road
 Edenton, NC 27932

Job J0322-1269	Truss A1GE	Truss Type GABLE	Qty 1	Ply 1	Lot 5 Cypress Road Job Reference (optional)	E16391026
-------------------	---------------	---------------------	----------	----------	--	-----------

Comtech, Inc. Fayetteville, NC - 28314,

8.430 s Aug 16 2021 MiTek Industries, Inc. Mon Nov 8 13:12:29 2021 Page 1

ID:J6aSr?qB6etazEy6hKRSkZzPTZ_r1N?0qNI?5b9?CfSzBRS_jyUylL26qXSNguQLZyLENW

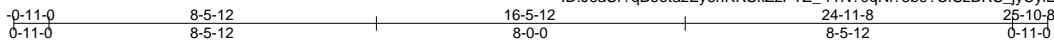

Scale = 1:56.2

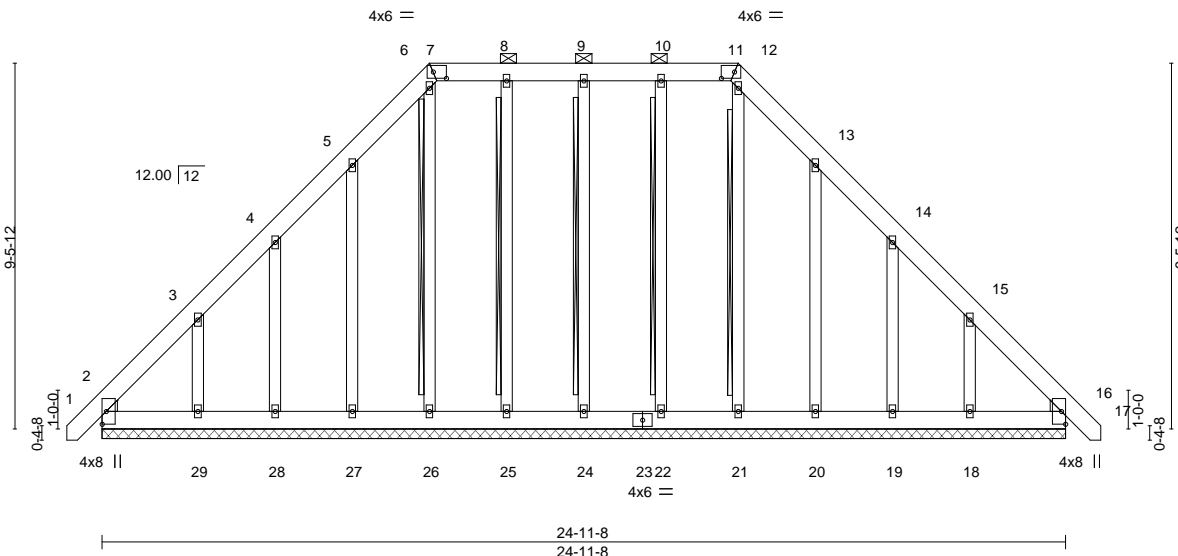

Plate Offsets (X,Y)-- [7:0-4-2,0-2-0], [11:0-4-2,0-2-0]

LOADING (psf)	SPACING-	CSI.	DEFL.	PLATES	GRIP
TCLL 20.0	2-0-0	TC 0.04	in (loc) l/defl L/d	MT20	244/190
TCDL 10.0	Plate Grip DOL 1.15	BC 0.03	Vert(LL) 0.00 16 n/r 120		
BCLL 0.0 *	Lumber DOL 1.15	WB 0.13	Vert(CT) 0.00 16 n/r 120		
BCDL 10.0	Rep Stress Incr YES	Matrix-S	Horz(CT) 0.01 16 n/a n/a		
	Code IRC2015/TPI2014			Weight: 245 lb	FT = 20%

LUMBER-
 TOP CHORD 2x6 SP No.1
 BOT CHORD 2x6 SP No.1
 OTHERS 2x4 SP No.2
 WEDGE
 Left: 2x4 SP No.2 , Right: 2x4 SP No.2

BRACING-
 TOP CHORD Structural wood sheathing directly applied or 6-0-0 oc purlins, except 2-0-0 oc purlins (6-0-0 max.): 7-11.
 BOT CHORD Rigid ceiling directly applied or 10-0-0 oc bracing.
 WEBS T-Brace: 2x4 SPF No.2 - 9-24, 8-25, 6-26, 10-22, 12-21
 Fasten (2X) T and I braces to narrow edge of web with 10d (0.131"x3") nails, 6in o.c., with 3in minimum end distance.
 Brace must cover 90% of web length.

REACTIONS. All bearings 24-11-8.
 (lb) - Max Horz 2=280(LC 11)
 Max Uplift All uplift 100 lb or less at joint(s) 24, 25, 26, 22, 16 except 2=114(LC 8), 27=130(LC 12), 28=135(LC 12), 29=221(LC 12), 20=125(LC 13), 19=136(LC 13), 18=214(LC 13)
 Max Grav All reactions 250 lb or less at joint(s) 2, 24, 25, 26, 27, 28, 22, 21, 20, 19, 18, 16 except 29=254(LC 19)

FORCES. (lb) - Max. Comp./Max. Ten. - All forces 250 (lb) or less except when shown.
 TOP CHORD 2-3=311/246

- NOTES-**
- Unbalanced roof live loads have been considered for this design.
 - Wind: ASCE 7-10; Vult=130mph Vasd=103mph; TCCL=6.0psf; BCDL=6.0psf; h=15ft; Cat. II; Exp C; Enclosed; MWFRS (envelope) gable end zone and C-C Exterior(2) zone; C-C for members and forces & MWFRS for reactions shown; Lumber DOL=1.60 plate grip DOL=1.60
 - Truss designed for wind loads in the plane of the truss only. For studs exposed to wind (normal to the face), see Standard Industry Gable End Details as applicable, or consult qualified building designer as per ANSI/TPI 1.
 - Provide adequate drainage to prevent water ponding.
 - All plates are 2x4 MT20 unless otherwise indicated.
 - Gable requires continuous bottom chord bearing.
 - Gable studs spaced at 2-0-0 oc.
 - This truss has been designed for a 10.0 psf bottom chord live load nonconcurrent with any other live loads.
 - * This truss has been designed for a live load of 30.0psf on the bottom chord in all areas where a rectangle 3-6-0 tall by 2-0-0 wide will fit between the bottom chord and any other members.
 - Provide mechanical connection (by others) of truss to bearing plate capable of withstanding 100 lb uplift at joint(s) 24, 25, 26, 22, 16 except (it=lb) 2=114, 27=130, 28=135, 29=221, 20=125, 19=136, 18=214.
 - Beveled plate or shim required to provide full bearing surface with truss chord at joint(s) 16.
 - Graphical purlin representation does not depict the size or the orientation of the purlin along the top and/or bottom chord.
 - Warning: Additional permanent and stability bracing for truss system (not part of this component design) is always required.



November 9, 2021

WARNING - Verify design parameters and READ NOTES ON THIS AND INCLUDED MITEK REFERENCE PAGE MII-7473 rev. 5/19/2020 BEFORE USE.
 Design valid for use only with MiTek® connectors. This design is based only upon parameters shown, and is for an individual building component, not a truss system. Before use, the building designer must verify the applicability of design parameters and properly incorporate this design into the overall building design. Bracing indicated is to prevent buckling of individual truss web and/or chord members only. Additional temporary and permanent bracing is always required for stability and to prevent collapse with possible personal injury and property damage. For general guidance regarding the fabrication, storage, delivery, erection and bracing of trusses and truss systems, see **ANSI/TPI1 Quality Criteria, DSB-89 and BCSI Building Component Safety Information** available from Truss Plate Institute, 2670 Crain Highway, Suite 203 Waldorf, MD 20601



818 Soundside Road
 Edenton, NC 27932

Job J0322-1269	Truss A2	Truss Type PIGGYBACK BASE	Qty 6	Ply 1	Lot 5 Cypress Road E16391027
-------------------	-------------	------------------------------	----------	----------	---------------------------------

Comtech, Inc. Fayetteville, NC - 28314,

8.430 s Aug 16 2021 MiTek Industries, Inc. Mon Nov 8 13:12:30 2021 Page 1

ID:J6aSr?qB6etazEy6hKRskZzPTZ_-JDxNDAONmPj0cMEfXuyhWxVZW9ZxrlvbcKezu?yLENV

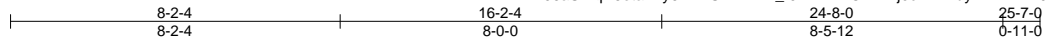

Scale = 1:53.9

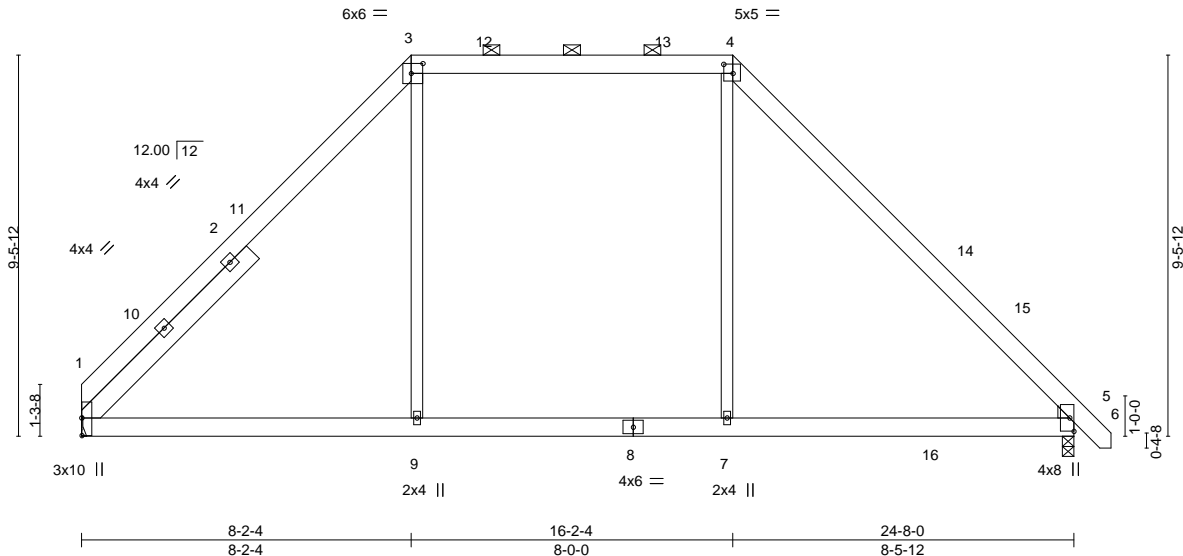

Plate Offsets (X,Y)-- [1:Edge,0-0-0], [3:0-3-8,0-3-0], [4:0-2-12,0-2-12]

LOADING (psf)	SPACING-	CSI.	DEFL.	PLATES	GRIP
TCLL 20.0	2-0-0	TC 0.44	in (loc) l/defl L/d	MT20	244/190
TCDL 10.0	Plate Grip DOL 1.15	BC 0.53	Vert(LL) -0.29 5-7 >999 360		
BCLL 0.0 *	Lumber DOL 1.15	WB 0.13	Vert(CT) -0.34 5-7 >861 240		
BCDL 10.0	Rep Stress Incr YES	Matrix-S	Horz(CT) 0.02 5 n/a n/a		
	Code IRC2015/TPI2014		Wind(LL) 0.19 5-7 >999 240	Weight: 176 lb	FT = 20%

LUMBER-

TOP CHORD 2x6 SP No.1
 BOT CHORD 2x6 SP No.1
 WEBS 2x4 SP No.2
 WEDGE
 Right: 2x4 SP No.2
 SLIDER Left 2x6 SP No.1 5-11-1

BRACING-

TOP CHORD Structural wood sheathing directly applied or 6-0-0 oc purlins, except 2-0-0 oc purlins (6-0-0 max.): 3-4.
 BOT CHORD Rigid ceiling directly applied or 10-0-0 oc bracing.

REACTIONS.

(size) 1=Mechanical, 5=0-3-8
 Max Horz 1=221(LC 8)
 Max Uplift 1=20(LC 12), 5=35(LC 13)
 Max Grav 1=1087(LC 2), 5=1249(LC 2)

FORCES.

(lb) - Max. Comp./Max. Ten. - All forces 250 (lb) or less except when shown.
 TOP CHORD 1-3=-1337/307, 3-4=815/353, 4-5=-1306/303
 BOT CHORD 1-9=-36/838, 7-9=-32/844, 5-7=-33/836
 WEBS 3-9=0/518, 4-7=0/562

NOTES-

- Unbalanced roof live loads have been considered for this design.
- Wind: ASCE 7-10; Vult=130mph Vasd=103mph; TCCL=6.0psf; BCCL=6.0psf; h=15ft; Cat. II; Exp C; Enclosed; MWFRS (envelope) and C-C Exterior(2) 0-0-0 to 4-4-13, Interior(1) 4-4-13 to 8-2-4, Exterior(2) 8-2-4 to 14-4-15, Interior(1) 14-4-15 to 16-2-4, Exterior(2) 16-2-4 to 22-4-15, Interior(1) 22-4-15 to 25-5-6 zone;C-C for members and forces & MWFRS for reactions shown; Lumber DOL=1.60 plate grip DOL=1.60
- Provide adequate drainage to prevent water ponding.
- This truss has been designed for a 10.0 psf bottom chord live load nonconcurrent with any other live loads.
- * This truss has been designed for a live load of 30.0psf on the bottom chord in all areas where a rectangle 3-6-0 tall by 2-0-0 wide will fit between the bottom chord and any other members, with BCDL = 10.0psf.
- Refer to girder(s) for truss to truss connections.
- Provide mechanical connection (by others) of truss to bearing plate capable of withstanding 100 lb uplift at joint(s) 1, 5.
- Graphical purlin representation does not depict the size or the orientation of the purlin along the top and/or bottom chord.



November 9,2021

WARNING - Verify design parameters and READ NOTES ON THIS AND INCLUDED MITEK REFERENCE PAGE MII-7473 rev. 5/19/2020 BEFORE USE.
 Design valid for use only with MiTek® connectors. This design is based only upon parameters shown, and is for an individual building component, not a truss system. Before use, the building designer must verify the applicability of design parameters and properly incorporate this design into the overall building design. Bracing indicated is to prevent buckling of individual truss web and/or chord members only. Additional temporary and permanent bracing is always required for stability and to prevent collapse with possible personal injury and property damage. For general guidance regarding the fabrication, storage, delivery, erection and bracing of trusses and truss systems, see ANS/TP11 Quality Criteria, DSB-89 and BCSI Building Component Safety Information available from Truss Plate Institute, 2670 Crain Highway, Suite 203 Waldorf, MD 20601



818 Soundside Road
 Edenton, NC 27932

Job J0322-1269	Truss A3	Truss Type PIGGYBACK BASE	Qty 12	Ply 1	Lot 5 Cypress Road Job Reference (optional)	E16391028
-------------------	-------------	------------------------------	-----------	----------	--	-----------

Comtech, Inc. Fayetteville, NC - 28314,

8.430 s Aug 16 2021 MiTek Industries, Inc. Mon Nov 8 13:12:31 2021 Page 1
ID:J6aSr?qb6etazEy6hKRskZzPTZ_-nPVIQWP?XjrtEVpr5cTw381jxZujaknlq_NXQRyLENU

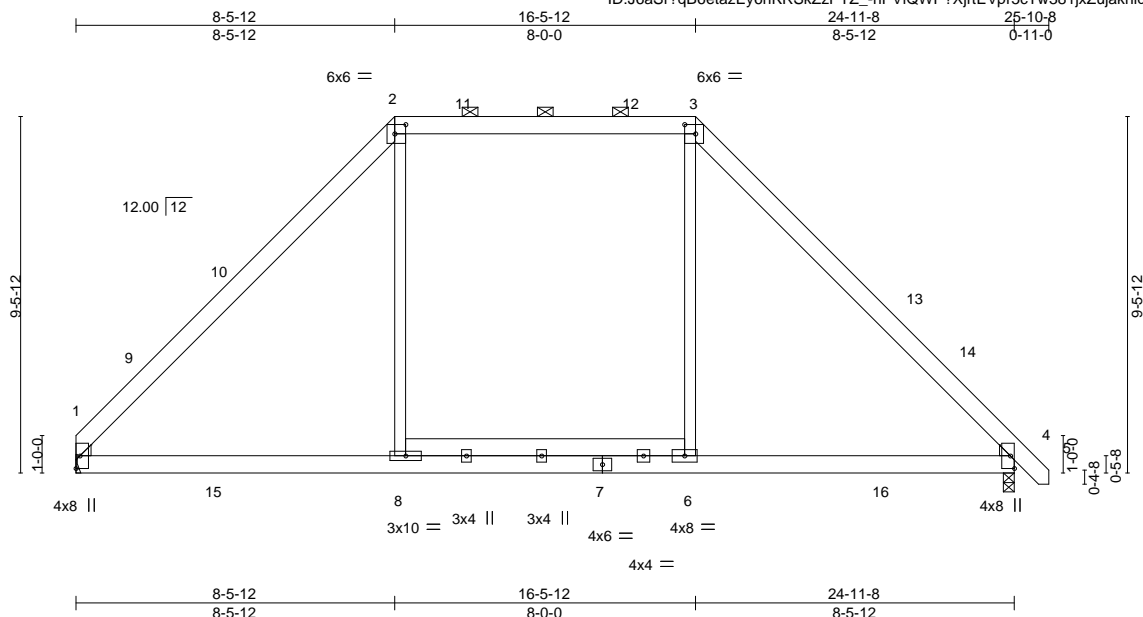

Scale = 1:57.7

Plate Offsets (X,Y)-- [2:0-3-8,0-3-0], [3:0-3-8,0-3-0]

LOADING (psf)	SPACING-	CSI.	DEFL.	in (loc)	I/defl	L/d	PLATES	GRIP
TCLL 20.0	2-0-0	TC 0.46	Vert(LL) -0.14	1-8	>999	360	MT20	244/190
TCDL 10.0	Plate Grip DOL 1.15	BC 0.53	Vert(CT) -0.19	1-8	>999	240		
BCLL 0.0 *	Lumber DOL 1.15	WB 0.15	Horz(CT) 0.02	4	n/a	n/a		
BCDL 10.0	Rep Stress Incr YES	Matrix-S	Wind(LL) 0.17	1-8	>999	240	Weight: 181 lb	FT = 20%
	Code IRC2015/TPI2014							

LUMBER-
TOP CHORD 2x6 SP No.1
BOT CHORD 2x6 SP No.1
WEBS 2x4 SP No.2
WEDGE
Left: 2x4 SP No.2, Right: 2x4 SP No.2

BRACING-
TOP CHORD Structural wood sheathing directly applied or 5-11-9 oc purlins, except
2-0-0 oc purlins (6-0-0 max.): 2-3.
BOT CHORD Rigid ceiling directly applied or 10-0-0 oc bracing.

REACTIONS. (size) 1=Mechanical, 4=0-3-8
Max Horz 1=221(LC 8)
Max Uplift 1=22(LC 12), 4=35(LC 13)
Max Grav 1=1263(LC 2), 4=1314(LC 2)

FORCES. (lb) - Max. Comp./Max. Ten. - All forces 250 (lb) or less except when shown.
TOP CHORD 1-2=1449/307, 2-3=925/359, 3-4=1489/315
BOT CHORD 1-8=35/947, 6-8=37/955, 4-6=32/944
WEBS 2-8=0/660, 3-6=0/667

- NOTES-**
- Unbalanced roof live loads have been considered for this design.
 - Wind: ASCE 7-10; Vult=130mph Vasd=103mph; TC DL=6.0psf; BCDL=6.0psf; h=15ft; Cat. II; Exp C; Enclosed; MWFRS (envelope) and C-C Exterior(2) 0-0-12 to 4-5-9, Interior(1) 4-5-9 to 8-5-12, Exterior(2) 8-5-12 to 14-8-7, Interior(1) 14-8-7 to 16-5-12, Exterior(2) 16-5-12 to 22-8-7, Interior(1) 22-8-7 to 25-8-14 zone; C-C for members and forces & MWFRS for reactions shown; Lumber DOL=1.60 plate grip DOL=1.60
 - Provide adequate drainage to prevent water ponding.
 - This truss has been designed for a 10.0 psf bottom chord live load nonconcurrent with any other live loads.
 - * This truss has been designed for a live load of 30.0psf on the bottom chord in all areas where a rectangle 3-6-0 tall by 2-0-0 wide will fit between the bottom chord and any other members, with BCDL = 10.0psf.
 - Refer to girder(s) for truss to truss connections.
 - Provide mechanical connection (by others) of truss to bearing plate capable of withstanding 100 lb uplift at joint(s) 1, 4.
 - Graphical purlin representation does not depict the size or the orientation of the purlin along the top and/or bottom chord.



November 9, 2021

WARNING - Verify design parameters and READ NOTES ON THIS AND INCLUDED MITTEK REFERENCE PAGE MII-7473 rev. 5/19/2020 BEFORE USE.
Design valid for use only with MiTek® connectors. This design is based only upon parameters shown, and is for an individual building component, not a truss system. Before use, the building designer must verify the applicability of design parameters and properly incorporate this design into the overall building design. Bracing indicated is to prevent buckling of individual truss web and/or chord members only. Additional temporary and permanent bracing is always required for stability and to prevent collapse with possible personal injury and property damage. For general guidance regarding the fabrication, storage, delivery, erection and bracing of trusses and truss systems, see **ANSI/TPI1 Quality Criteria, DSB-89 and BCSI Building Component Safety Information** available from Truss Plate Institute, 2670 Crain Highway, Suite 203 Waldorf, MD 20601



818 Soundside Road
Edenton, NC 27932

Job J0322-1269	Truss A3GE	Truss Type GABLE	Qty 1	Ply 1	Lot 5 Cypress Road Job Reference (optional)	E16391029
-------------------	---------------	---------------------	----------	----------	--	-----------

Comtech, Inc. Fayetteville, NC - 28314,

8.430 s Aug 16 2021 MiTek Industries, Inc. Mon Nov 8 13:12:32 2021 Page 1
 ID:J6aSr?qB6etazEy6hKRSkZzPTZ_-Fc37esQdl0zksfN1eJ_9bMa?CzMJAGu3e74yuyLENT
 24-11-8 25-10-8
 8-5-12 0-11-0

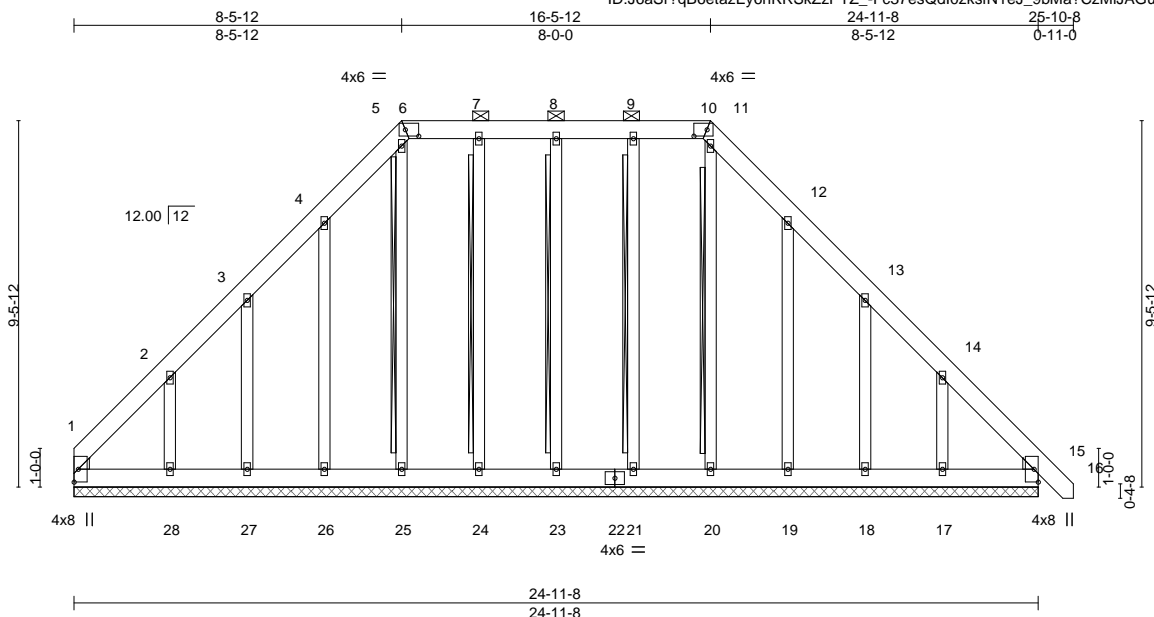

Scale = 1:56.1

Plate Offsets (X,Y)-- [6:0-4-2,0-2-0], [10:0-4-2,0-2-0]

LOADING (psf)	SPACING-	CSI.	DEFL.	PLATES	GRIP
TCLL 20.0	2-0-0	TC 0.04	in (loc) l/defl L/d	MT20	244/190
TCDL 10.0	Plate Grip DOL 1.15	BC 0.03	Vert(LL) 0.00 15 n/r 120		
BCLL 0.0 *	Lumber DOL 1.15	WB 0.13	Vert(CT) 0.00 15 n/r 120		
BCDL 10.0	Rep Stress Incr YES	Matrix-S	Horz(CT) 0.01 15 n/a n/a		
	Code IRC2015/TPI2014			Weight: 242 lb	FT = 20%

LUMBER-
 TOP CHORD 2x6 SP No.1
 BOT CHORD 2x6 SP No.1
 OTHERS 2x4 SP No.2
 WEDGE
 Left: 2x4 SP No.2, Right: 2x4 SP No.2

BRACING-
 TOP CHORD Structural wood sheathing directly applied or 6-0-0 oc purlins, except 2-0-0 oc purlins (6-0-0 max.): 6-10.
 Rigid ceiling directly applied or 10-0-0 oc bracing.
 BOT CHORD
 WEBS T-Brace: 2x4 SPF No.2 - 8-23, 7-24, 5-25, 9-21, 11-20
 Fasten (2X) T and I braces to narrow edge of web with 10d (0.131"x3") nails, 6in o.c., with 3in minimum end distance.
 Brace must cover 90% of web length.

REACTIONS. All bearings 24-11-8.
 (lb) - Max Horz 1=-277(LC 8)
 Max Uplift All uplift 100 lb or less at joint(s) 23, 24, 25, 21, 15 except 26=-129(LC 12), 27=-134(LC 12), 28=-228(LC 12), 19=-125(LC 13), 18=-136(LC 13), 17=-214(LC 13), 1=-120(LC 10)
 Max Grav All reactions 250 lb or less at joint(s) 23, 24, 25, 26, 27, 21, 20, 19, 18, 17, 1, 15 except 28=266(LC 19)

FORCES. (lb) - Max. Comp./Max. Ten. - All forces 250 (lb) or less except when shown.
 TOP CHORD 1-2=-317/250
 WEBS 2-28=-252/242

NOTES-

- Unbalanced roof live loads have been considered for this design.
- Wind: ASCE 7-10; Vult=130mph Vasd=103mph; TCDL=6.0psf; BCDL=6.0psf; h=15ft; Cat. II; Exp C; Enclosed; MWFRS (envelope) gable end zone and C-C Exterior(2) zone; C-C for members and forces & MWFRS for reactions shown; Lumber DOL=1.60 plate grip DOL=1.60
- Truss designed for wind loads in the plane of the truss only. For studs exposed to wind (normal to the face), see Standard Industry Gable End Details as applicable, or consult qualified building designer as per ANSI/TPI 1.
- Provide adequate drainage to prevent water ponding.
- All plates are 2x4 MT20 unless otherwise indicated.
- Gable requires continuous bottom chord bearing.
- Gable studs spaced at 2-0-0 oc.
- This truss has been designed for a 10.0 psf bottom chord live load nonconcurrent with any other live loads.
- * This truss has been designed for a live load of 30.0psf on the bottom chord in all areas where a rectangle 3-6-0 tall by 2-0-0 wide will fit between the bottom chord and any other members.
- Provide mechanical connection (by others) of truss to bearing plate capable of withstanding 100 lb uplift at joint(s) 23, 24, 25, 21, 15 except (jt=lb) 26=129, 27=134, 28=228, 19=125, 18=136, 17=214, 1=120.
- Beveled plate or shim required to provide full bearing surface with truss chord at joint(s) 15.
- Graphical purlin representation does not depict the size or the orientation of the purlin along the top and/or bottom chord.
- Warning: Additional permanent and stability bracing for truss system (not part of this component design) is always required.



November 9, 2021

WARNING - Verify design parameters and READ NOTES ON THIS AND INCLUDED MITEK REFERENCE PAGE MII-7473 rev. 5/19/2020 BEFORE USE.
 Design valid for use only with MiTek® connectors. This design is based only upon parameters shown, and is for an individual building component, not a truss system. Before use, the building designer must verify the applicability of design parameters and properly incorporate this design into the overall building design. Bracing indicated is to prevent buckling of individual truss web and/or chord members only. Additional temporary and permanent bracing is always required for stability and to prevent collapse with possible personal injury and property damage. For general guidance regarding the fabrication, storage, delivery, erection and bracing of trusses and truss systems, see **ANSI/TPI1 Quality Criteria, DSB-89 and BCSI Building Component Safety Information** available from Truss Plate Institute, 2670 Crain Highway, Suite 203 Waldorf, MD 20601



818 Soundside Road
 Edenton, NC 27932

Job J0322-1269	Truss B1	Truss Type ATTIC	Qty 6	Ply 1	Lot 5 Cypress Road Job Reference (optional)	E16391030
-------------------	-------------	---------------------	----------	----------	--	-----------

Comtech, Inc. Fayetteville, NC - 28314,

8.430 s Aug 16 2021 MiTek Industries, Inc. Mon Nov 8 13:12:33 2021 Page 1
ID:J6aSr?qB6etazEy6hKRSkZzPTZ_ajodWrcQF3K6bTpyDC1VO8Z7?ANYi2dV2IIsdVKyLENS

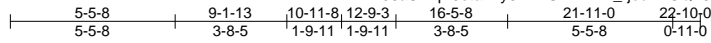

6x8 =

Scale = 1:71.8

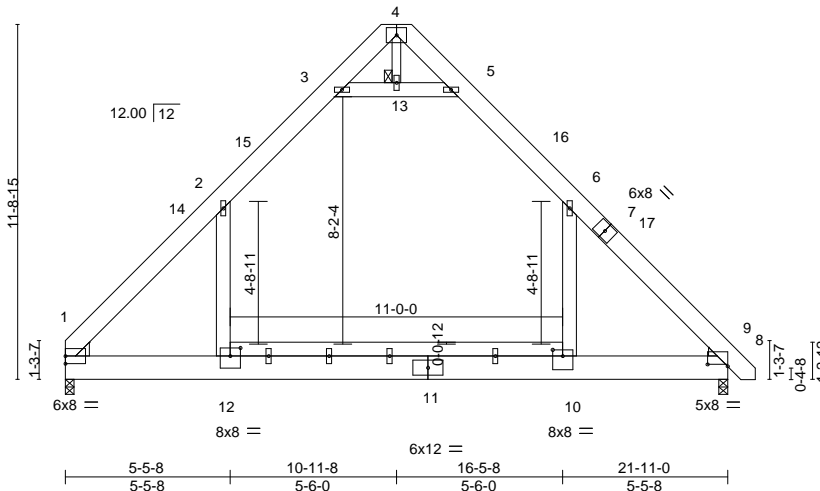

Plate Offsets (X,Y)-- [8:0-8-0,0-0-13], [10:0-4-0,0-2-8], [12:0-4-0,0-3-4]

LOADING (psf)	SPACING-	CSI.	DEFL.	in (loc)	l/defl	L/d	PLATES	GRIP
TCLL 20.0	2-0-0	TC 0.73	Vert(LL)	-0.21 10-12	>999	360	MT20	244/190
TCDL 10.0	Plate Grip DOL 1.15	BC 0.69	Vert(CT)	-0.36 10-12	>720	240		
BCLL 0.0 *	Lumber DOL 1.15	WB 0.14	Horz(CT)	0.01 8	n/a	n/a		
BCDL 10.0	Rep Stress Incr YES	Matrix-S	Wind(LL)	0.08 10-12	>999	240	Weight: 248 lb	FT = 20%
	Code IRC2015/TPI2014							

LUMBER-

TOP CHORD 2x8 SP No.1
 BOT CHORD 2x10 SP No.1 *Except*
 10-12: 2x6 SP No.1
 WEBS 2x6 SP No.1 *Except*
 4-13: 2x4 SP No.2

WEDGE

Left: 2x6 SP No.2, Right: 2x4 SP No.3

REACTIONS.

(size) 1=0-3-8, 8=0-3-8
 Max Horz 1=277(LC 8)
 Max Grav 1=1413(LC 21), 8=1459(LC 21)

FORCES.

(lb) - Max. Comp./Max. Ten. - All forces 250 (lb) or less except when shown.
 TOP CHORD 1-2=-1867/0, 2-3=-1036/152, 3-4=-37/438, 4-5=-42/447, 5-6=-1028/148, 6-8=-1930/0
 BOT CHORD 1-12=0/1085, 10-12=0/1085, 8-10=0/1085
 WEBS 6-10=0/975, 2-12=0/889, 3-13=-1621/246, 5-13=-1621/246

NOTES-

- Unbalanced roof live loads have been considered for this design.
- Wind: ASCE 7-10; Vult=130mph Vasd=103mph; TCDL=6.0psf; BCDL=6.0psf; h=15ft; Cat. II; Exp C; Enclosed; MWFRS (envelope) and C-C Exterior(2) 0-0-0 to 4-4-13, Interior(1) 4-4-13 to 10-11-8, Exterior(2) 10-11-8 to 15-4-5, Interior(1) 15-4-5 to 22-7-2 zone; C-C for members and forces & MWFRS for reactions shown; Lumber DOL=1.60 plate grip DOL=1.60
- All plates are 2x6 MT20 unless otherwise indicated.
- This truss has been designed for a 10.0 psf bottom chord live load nonconcurrent with any other live loads.
- * This truss has been designed for a live load of 30.0psf on the bottom chord in all areas where a rectangle 3-6-0 tall by 2-0-0 wide will fit between the bottom chord and any other members.
- Ceiling dead load (10.0 psf) on member(s). 2-3, 5-6, 3-13, 5-13; Wall dead load (5.0psf) on member(s).6-10, 2-12
- Bottom chord live load (40.0 psf) and additional bottom chord dead load (10.0 psf) applied only to room. 10-12
- Attic room checked for L/360 deflection.



November 9, 2021

WARNING - Verify design parameters and READ NOTES ON THIS AND INCLUDED MITEK REFERENCE PAGE MII-7473 rev. 5/19/2020 BEFORE USE.

Design valid for use only with MiTek® connectors. This design is based only upon parameters shown, and is for an individual building component, not a truss system. Before use, the building designer must verify the applicability of design parameters and properly incorporate this design into the overall building design. Bracing indicated is to prevent buckling of individual truss web and/or chord members only. Additional temporary and permanent bracing is always required for stability and to prevent collapse with possible personal injury and property damage. For general guidance regarding the fabrication, storage, delivery, erection and bracing of trusses and truss systems, see **ANSI/TPI1 Quality Criteria, DSB-89 and BCSI Building Component Safety Information** available from Truss Plate Institute, 2670 Crain Highway, Suite 203 Waldorf, MD 20601



818 Soundside Road
 Edenton, NC 27932

Job J0322-1269	Truss B1-GR	Truss Type ATTIC	Qty 1	Ply 3	Lot 5 Cypress Road Job Reference (optional)	E16391031
-------------------	----------------	---------------------	----------	----------	--	-----------

Comtech, Inc, Fayetteville, NC - 28314,

8.430 s Aug 16 2021 MiTek Industries, Inc. Mon Nov 8 13:12:36 2021 Page 1

ID:J6aSr?qB6etazEy6hKRSkZzPTZ_-7NleUDT8LFUAKHhot935mCIWcaZfXRU_G5I5fyLENP

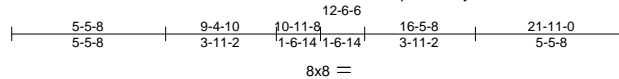

Scale = 1:77.0

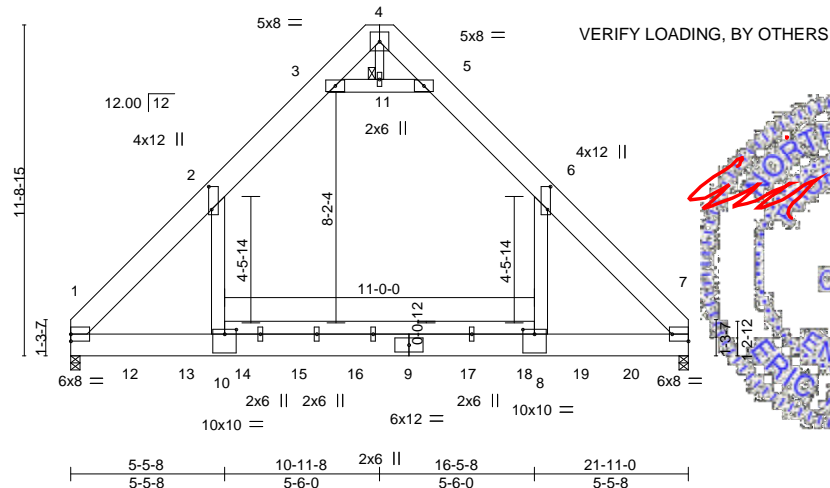

Plate Offsets (X,Y)-- [2:0-9-12,0-1-4], [6:0-9-12,0-1-4], [7:Edge,0-3-0], [8:0-5-0,0-2-0], [10:0-5-0,0-2-0]

LOADING (psf)	SPACING-	CSI.	DEFL.	PLATES	GRIP
TCLL 20.0	2-0-0	TC 0.72	in (loc) l/defl L/d	MT20	244/190
TCDL 10.0	Plate Grip DOL 1.15	BC 0.76	Vert(LL) -0.29 8-10 >905 360		
BCLL 0.0 *	Lumber DOL 1.15	WB 0.38	Vert(CT) -0.39 8-10 >666 240		
BCDL 10.0	Rep Stress Incr NO	Matrix-S	Horz(CT) 0.02 7 n/a n/a		
	Code IRC2015/TP12014		Wind(LL) 0.01 10 >999 240		
				Weight: 801 lb	FT = 20%

LUMBER-

TOP CHORD 2x10 SP 2400F 2.0E
 BOT CHORD 2x10 SP No.1 *Except*
 8-10: 2x6 SP No.1
 WEBS 2x6 SP No.1 *Except*
 4-11: 2x4 SP No.2

BRACING-

TOP CHORD Structural wood sheathing directly applied or 6-0-0 oc purlins.
 BOT CHORD Rigid ceiling directly applied or 10-0-0 oc bracing.
 JOINTS 1 Brace at Jt(s): 11

REACTIONS.

(size) 1=0-4-0, 7=0-4-0
 Max Horz 1=271(LC 5)
 Max Grav 1=9588(LC 14), 7=9573(LC 14)

FORCES.

(lb) - Max. Comp./Max. Ten. - All forces 250 (lb) or less except when shown.
 TOP CHORD 1-2=-10113/0, 2-3=-4213/35, 3-4=-19/3638, 4-5=-20/3649, 5-6=-4203/35, 6-7=-10124/0
 BOT CHORD 1-10=0/5656, 8-10=0/5720, 7-8=0/5656
 WEBS 6-8=0/8207, 2-10=0/8177, 3-11=-11296/4, 5-11=-11296/4, 4-11=0/835

NOTES-

- 3-ply truss to be connected together with 10d (0.131"x3") nails as follows:
 Top chords connected as follows: 2x10 - 2 rows staggered at 0-9-0 oc.
 Bottom chords connected as follows: 2x10 - 5 rows staggered at 0-4-0 oc.
 Webs connected as follows: 2x6 - 2 rows staggered at 0-9-0 oc, 2x4 - 1 row at 0-9-0 oc.
- All loads are considered equally applied to all plies, except if noted as front (F) or back (B) face in the LOAD CASE(S) section. Ply to ply connections have been provided to distribute only loads noted as (F) or (B), unless otherwise indicated.
- Unbalanced roof live loads have been considered for this design.
- Wind: ASCE 7-10; Vult=130mph Vasd=103mph; TCCL=6.0psf; BCCL=6.0psf; h=15ft; Cat. II; Exp C; Enclosed; MWFRS (envelope); Lumber DOL=1.60 plate grip DOL=1.60
- Concentrated loads from layout are not present in Load Case(s): #3 Dead + Uninhabitable Attic Without Storage; #4 Dead + 0.6 MWFRS Wind (Pos. Internal) Left; #5 Dead + 0.6 MWFRS Wind (Pos. Internal) Right; #6 Dead + 0.6 MWFRS Wind (Neg. Internal) Left; #7 Dead + 0.6 MWFRS Wind (Neg. Internal) Right; #8 Dead + 0.6 MWFRS Wind (Pos. Internal) 1st Parallel; #9 Dead + 0.6 MWFRS Wind (Pos. Internal) 2nd Parallel; #10 Dead + 0.6 MWFRS Wind (Pos. Internal) 3rd Parallel; #11 Dead + 0.6 MWFRS Wind (Pos. Internal) 4th Parallel; #12 Dead + 0.6 MWFRS Wind (Neg. Internal) 1st Parallel; #13 Dead + 0.6 MWFRS Wind (Neg. Internal) 2nd Parallel; #20 Dead + 0.75 Roof Live (bal.) + 0.75 Attic Floor + 0.75(0.6 MWFRS Wind (Neg. Int) Left); #21 Dead + 0.75 Roof Live (bal.) + 0.75 Attic Floor + 0.75(0.6 MWFRS Wind (Neg. Int) Right); #22 Dead + 0.75 Roof Live (bal.) + 0.75 Attic Floor + 0.75(0.6 MWFRS Wind (Neg. Int) 1st Parallel); #23 Dead + 0.75 Roof Live (bal.) + 0.75 Attic Floor + 0.75(0.6 MWFRS Wind (Neg. Int) 2nd Parallel).

November 9,2021

Continued on page 2 - Design for a 10.0 psf bottom chord live load nonconcurrent with any other live loads.

WARNING - Verify design parameters and READ NOTES ON THIS AND INCLUDED MITEK REFERENCE PAGE MII-7473 rev. 5/19/2020 BEFORE USE.
 Design valid for use only with MiTek® connectors. This design is based only upon parameters shown, and is for an individual building component, not a truss system. Before use, the building designer must verify the applicability of design parameters and properly incorporate this design into the overall building design. Bracing indicated is to prevent buckling of individual truss web and/or chord members only. Additional temporary and permanent bracing is always required for stability and to prevent collapse with possible personal injury and property damage. For general guidance regarding the fabrication, storage, delivery, erection and bracing of trusses and truss systems, see **ANSI/TP11 Quality Criteria, DSB-89 and BCSI Building Component Safety Information** available from Truss Plate Institute, 2670 Crain Highway, Suite 203 Waldorf, MD 20601



818 Soundside Road
 Edenton, NC 27932

Job	Truss	Truss Type	Qty	Ply	Lot 5 Cypress Road	E16391031
J0322-1269	B1-GR	ATTIC	1	3	Job Reference (optional)	

Comtech, Inc, Fayetteville, NC - 28314,

8.430 s Aug 16 2021 MiTek Industries, Inc. Mon Nov 8 13:12:36 2021 Page 2
ID:J6aSr?qB6etazEy6hKRSkZzPTZ_-7NleUDT8LFUAKHhot935mCIWcaZIFxRU_G5I5fyLENP

NOTES-

- 7) * This truss has been designed for a live load of 30.0psf on the bottom chord in all areas where a rectangle 3-6-0 tall by 2-0-0 wide will fit between the bottom chord and any other members.
- 8) Ceiling dead load (10.0 psf) on member(s). 2-3, 5-6, 3-11, 5-11; Wall dead load (5.0psf) on member(s).6-8, 2-10
- 9) Bottom chord live load (40.0 psf) and additional bottom chord dead load (10.0 psf) applied only to room. 8-10
- 10) Hanger(s) or other connection device(s) shall be provided sufficient to support concentrated load(s) 1726 lb down at 1-11-12, 1726 lb down at 3-11-12, 3826 lb down at 5-2-12, 376 lb down and 34 lb up at 5-11-12, 376 lb down and 34 lb up at 7-11-12, 376 lb down and 34 lb up at 9-11-12, 376 lb down and 34 lb up at 11-11-12, 376 lb down and 34 lb up at 13-11-12, 376 lb down and 34 lb up at 15-11-12, 3826 lb down at 16-8-4, and 1726 lb down at 17-11-12, and 1726 lb down at 19-9-4 on bottom chord. The design/selection of such connection device(s) is the responsibility of others.
- 11) Attic room checked for L/360 deflection.

LOAD CASE(S) Standard

- 1) Dead + Roof Live (balanced): Lumber Increase=1.15, Plate Increase=1.15

Uniform Loads (plf)

Vert: 1-2=-60, 2-3=-80, 3-4=-60, 4-5=-60, 5-6=-80, 6-7=-60, 1-10=-20, 8-10=-40, 7-8=-20, 3-5=-20
Drag: 6-8=-10, 2-10=-10

Concentrated Loads (lb)

Vert: 9=-62(B) 8=-1029(B) 10=-1029(B) 12=-430(B) 13=-430(B) 14=-62(B) 15=-62(B) 16=-62(B) 17=-62(B) 18=-62(B) 19=-430(B) 20=-430(B)

WARNING - Verify design parameters and READ NOTES ON THIS AND INCLUDED MITEK REFERENCE PAGE MII-7473 rev. 5/19/2020 BEFORE USE.

Design valid for use only with MiTek® connectors. This design is based only upon parameters shown, and is for an individual building component, not a truss system. Before use, the building designer must verify the applicability of design parameters and properly incorporate this design into the overall building design. Bracing indicated is to prevent buckling of individual truss web and/or chord members only. Additional temporary and permanent bracing is always required for stability and to prevent collapse with possible personal injury and property damage. For general guidance regarding the fabrication, storage, delivery, erection and bracing of trusses and truss systems, see

Safety Information available from Truss Plate Institute, 2670 Crain Highway, Suite 203 Waldorf, MD 20601 **ANSI/TPI1 Quality Criteria, DSB-89 and BCSI Building Component**



818 Soundside Road
Edenton, NC 27932

Job J0322-1269	Truss B1GE	Truss Type GABLE	Qty 1	Ply 1	Lot 5 Cypress Road Job Reference (optional)	E16391032
-------------------	---------------	---------------------	----------	----------	--	-----------

Comtech, Inc. Fayetteville, NC - 28314.

8.430 s Aug 16 2021 MiTek Industries, Inc. Mon Nov 8 13:12:34 2021 Page 1
ID:J6aSr7qB6etazEy6hKRSkZzPTZ_-B_Bu3XRtqeES5zXQmk0dhnfA4mvzn4HBWycB1myLENR

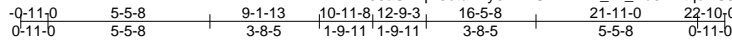

6x8 =

Scale = 1:73.2

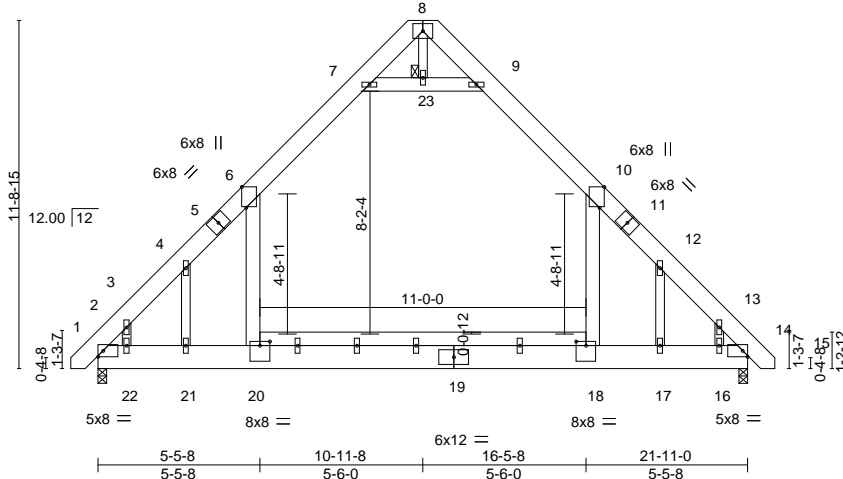

Plate Offsets (X,Y)-- [6:0-8-6,Edge], [10:0-8-6,Edge], [18:0-4-0,0-1-12], [20:0-4-0,0-1-12]

LOADING (psf)	SPACING-	CSI.	DEFL.	in (loc)	l/defl	L/d	PLATES	GRIP
TCLL 20.0	Plate Grip DOL 2-0-0	TC 0.72	Vert(LL) -0.17	18-20	>999	360	MT20	244/190
TCDL 10.0	Lumber DOL 1.15	BC 0.63	Vert(CT) -0.30	18-20	>855	240		
BCLL 0.0 *	Rep Stress Incr YES	WB 0.17	Horz(CT) 0.01	14	n/a	n/a		
BCDL 10.0	Code IRC2015/TPI2014	Matrix-S	Wind(LL) 0.08	18-20	>999	240	Weight: 261 lb	FT = 20%

LUMBER-

TOP CHORD 2x8 SP No.1
 BOT CHORD 2x10 SP No.1 *Except*
 18-20: 2x6 SP No.1
 WEBS 2x6 SP No.1 *Except*
 8-23: 2x4 SP No.2
 OTHERS 2x4 SP No.2

BRACING-

TOP CHORD Structural wood sheathing directly applied or 5-0-0 oc purlins.
 BOT CHORD Rigid ceiling directly applied or 10-0-0 oc bracing.
 JOINTS 1 Brace at Jt(s): 23

REACTIONS.

(size) 2=0-3-8, 14=0-3-8
 Max Horz 2=349(LC 11)
 Max Grav 2=1443(LC 20), 14=1443(LC 21)

FORCES.

(lb) - Max. Comp./Max. Ten. - All forces 250 (lb) or less except when shown.
 TOP CHORD 2-3=-1821/0, 3-4=-1558/0, 4-6=-1957/23, 6-7=-1028/184, 7-8=-60/389, 8-9=-61/390,
 9-10=-1028/184, 10-12=-1956/22, 12-13=-1557/0, 13-14=-1821/0
 BOT CHORD 2-22=0/1098, 21-22=0/1110, 20-21=0/1095, 18-20=0/1095, 17-18=0/1095, 16-17=0/1109,
 14-16=0/1092
 WEBS 10-18=0/1192, 6-20=0/1192, 7-23=-1506/324, 9-23=-1506/324, 4-21=-717/135,
 3-22=0/341, 12-17=-717/135, 13-16=0/341

NOTES-

- Unbalanced roof live loads have been considered for this design.
- Wind: ASCE 7-10; Vult=130mph Vasd=103mph; TCCL=6.0psf; BCDL=6.0psf; h=15ft; Cat. II; Exp C; Enclosed; MWFRS (envelope) gable end zone and C-C Exterior(2) zone; C-C for members and forces & MWFRS for reactions shown; Lumber DOL=1.60 plate grip DOL=1.60
- Truss designed for wind loads in the plane of the truss only. For studs exposed to wind (normal to the face), see Standard Industry Gable End Details as applicable, or consult qualified building designer as per ANSI/TPI 1.
- All plates are 2x6 MT20 unless otherwise indicated.
- Gable studs spaced at 2-0-0 oc.
- This truss has been designed for a 10.0 psf bottom chord live load nonconcurrent with any other live loads.
- * This truss has been designed for a live load of 30.0psf on the bottom chord in all areas where a rectangle 3-6-0 tall by 2-0-0 wide will fit between the bottom chord and any other members.
- Ceiling dead load (10.0 psf) on member(s). 6-7, 9-10, 7-23, 9-23; Wall dead load (5.0psf) on member(s).10-18, 6-20
- Bottom chord live load (40.0 psf) and additional bottom chord dead load (10.0 psf) applied only to room. 18-20
- Attic room checked for L/360 deflection.



November 9,2021

WARNING - Verify design parameters and READ NOTES ON THIS AND INCLUDED MITTEK REFERENCE PAGE MII-7473 rev. 5/19/2020 BEFORE USE.
 Design valid for use only with MiTek® connectors. This design is based only upon parameters shown, and is for an individual building component, not a truss system. Before use, the building designer must verify the applicability of design parameters and properly incorporate this design into the overall building design. Bracing indicated is to prevent buckling of individual truss web and/or chord members only. Additional temporary and permanent bracing is always required for stability and to prevent collapse with possible personal injury and property damage. For general guidance regarding the fabrication, storage, delivery, erection and bracing of trusses and truss systems, see **ANSI/TPI1 Quality Criteria, DSB-89 and BCSI Building Component Safety Information** available from Truss Plate Institute, 2670 Crain Highway, Suite 203 Waldorf, MD 20601



818 Soundside Road
 Edenton, NC 27932

Job J0322-1269	Truss C1	Truss Type COMMON	Qty 2	Ply 1	Lot 5 Cypress Road Job Reference (optional)	E16391033
-------------------	-------------	----------------------	----------	----------	--	-----------

Comtech, Inc. Fayetteville, NC - 28314,

8.430 s Aug 16 2021 MiTek Industries, Inc. Mon Nov 8 13:12:37 2021 Page 1

0-11-0 5-4-12 11-4-12 17-4-12 22-9-8 23-8-8
 0-11-0 5-4-12 6-0-0 6-0-0 5-4-12 0-11-0

5x8 =

Scale = 1:68.6

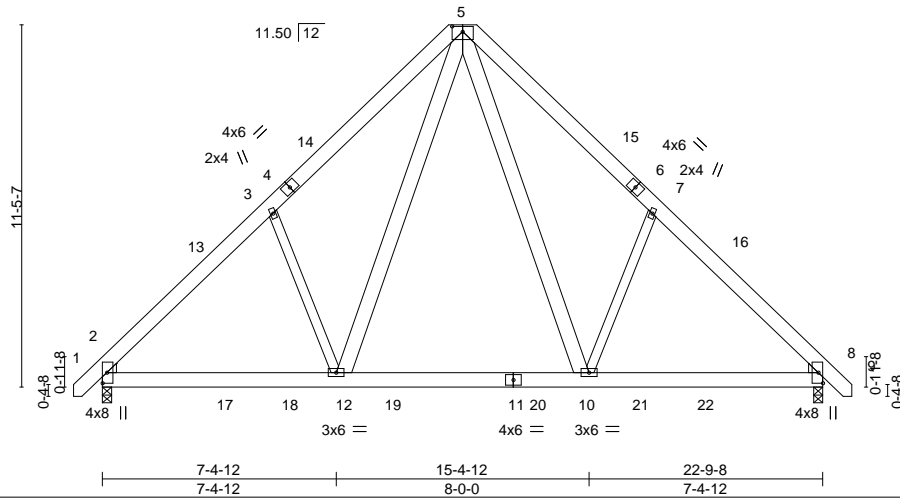

Plate Offsets (X,Y)-- [5:0-4-0,0-2-0]

LOADING (psf)	SPACING- 2-0-0	CSI.	DEFL. in (loc) l/defl L/d	PLATES	GRIP
TCLL 20.0	Plate Grip DOL 1.15	TC 0.18	Vert(LL) -0.05 10-12 >999 360	MT20	244/190
TCDL 10.0	Lumber DOL 1.15	BC 0.26	Vert(CT) -0.07 10-12 >999 240		
BCLL 0.0 *	Rep Stress Incr YES	WB 0.27	Horz(CT) 0.01 8 n/a n/a		
BCDL 10.0	Code IRC2015/TPI2014	Matrix-S	Wind(LL) 0.01 2-12 >999 240	Weight: 204 lb	FT = 20%

LUMBER-

TOP CHORD 2x6 SP No.1
 BOT CHORD 2x6 SP No.1
 WEBS 2x6 SP No.1 *Except*
 7-10,3-12: 2x4 SP No.2

WEDGE

Left: 2x4 SP No.2, Right: 2x4 SP No.2

REACTIONS.

(size) 2=0-3-8, 8=0-3-8
 Max Horz 2=280(LC 10)
 Max Uplift 2=42(LC 12), 8=42(LC 13)
 Max Grav 2=1057(LC 19), 8=1057(LC 20)

FORCES. (lb) - Max. Comp./Max. Ten. - All forces 250 (lb) or less except when shown.

TOP CHORD 2-3=1210/251, 3-5=1109/415, 5-7=1110/415, 7-8=1210/251
 BOT CHORD 2-12=91/943, 10-12=0/619, 8-10=42/811
 WEBS 5-10=201/658, 7-10=406/304, 5-12=201/657, 3-12=406/304

NOTES-

- Unbalanced roof live loads have been considered for this design.
- Wind: ASCE 7-10; Vult=130mph Vasd=103mph; TCDL=6.0psf; BCDL=6.0psf; h=15ft; Cat. II; Exp C; Enclosed; MWFRS (envelope) and C-C Exterior(2) -0-9-6 to 3-7-7, Interior(1) 3-7-7 to 11-4-12, Exterior(2) 11-4-12 to 15-9-9, Interior(1) 15-9-9 to 23-6-14 zone;C-C for members and forces & MWFRS for reactions shown; Lumber DOL=1.60 plate grip DOL=1.60
- This truss has been designed for a 10.0 psf bottom chord live load nonconcurrent with any other live loads.
- * This truss has been designed for a live load of 30.0psf on the bottom chord in all areas where a rectangle 3-6-0 tall by 2-0-0 wide will fit between the bottom chord and any other members, with BCDL = 10.0psf.
- Provide mechanical connection (by others) of truss to bearing plate capable of withstanding 100 lb uplift at joint(s) 2, 8.



November 9,2021

WARNING - Verify design parameters and READ NOTES ON THIS AND INCLUDED MITTEK REFERENCE PAGE MII-7473 rev. 5/19/2020 BEFORE USE.

Design valid for use only with MiTek® connectors. This design is based only upon parameters shown, and is for an individual building component, not a truss system. Before use, the building designer must verify the applicability of design parameters and properly incorporate this design into the overall building design. Bracing indicated is to prevent buckling of individual truss web and/or chord members only. Additional temporary and permanent bracing is always required for stability and to prevent collapse with possible personal injury and property damage. For general guidance regarding the fabrication, storage, delivery, erection and bracing of trusses and truss systems, see **ANSI/TPI1 Quality Criteria, DSB-89 and BCSI Building Component Safety Information** available from Truss Plate Institute, 2670 Crain Highway, Suite 203 Waldorf, MD 20601



818 Soundside Road
 Edenton, NC 27932

Job J0322-1269	Truss C1-GR	Truss Type COMMON GIRDER	Qty 1	Ply 2	Lot 5 Cypress Road Job Reference (optional)	E16391034
-------------------	----------------	-----------------------------	----------	----------	--	-----------

Comtech, Inc. Fayetteville, NC - 28314,

8.430 s Aug 16 2021 MiTek Industries, Inc. Mon Nov 8 13:12:40 2021 Page 1
ID:J6aSr?qb6etazEyGhKRSkZzPTZ_-08Y9JbWePU_bpu?a6?71w2vITB?wBcg4vu3VEQyLENL

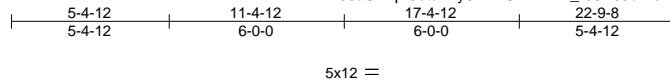

Scale = 1:74.3

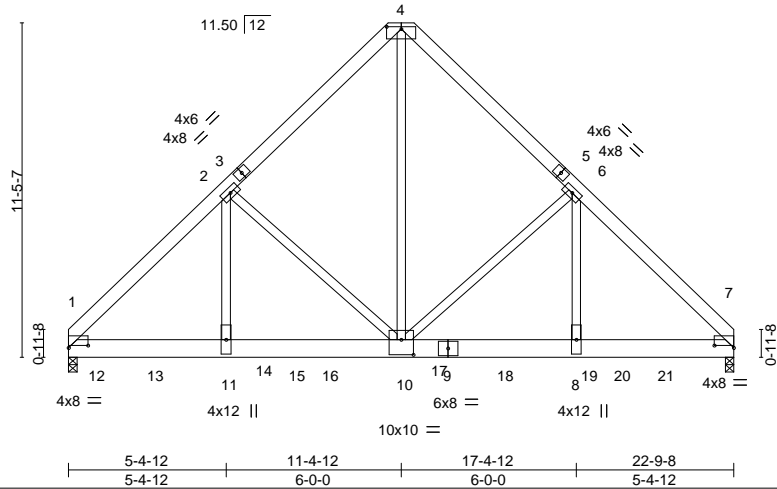

Plate Offsets (X,Y)-- [1:0-8-0,0-0-15], [4:0-6-0,0-1-0], [7:0-8-0,0-0-15], [10:0-5-0,0-6-4]

LOADING (psf)	SPACING-	CSI.	DEFL.	in (loc)	l/defl	L/d	PLATES	GRIP
TCLL 20.0	2-0-0 Plate Grip DOL 1.15	TC 0.28	Vert(LL) -0.10	8-10	>999	360	MT20	244/190
TCDL 10.0	Lumber DOL 1.15	BC 0.40	Vert(CT) -0.17	8-10	>999	240		
BCLL 0.0 *	Rep Stress Incr NO	WB 0.94	Horz(CT) 0.04	7	n/a	n/a		
BCDL 10.0	Code IRC2015/TPI2014	Matrix-S	Wind(LL) 0.05	8-10	>999	240	Weight: 396 lb	FT = 20%

LUMBER-
 TOP CHORD 2x6 SP No.1
 BOT CHORD 2x8 SP 2400F 2.0E
 WEBS 2x4 SP No.2

BRACING-
 TOP CHORD Structural wood sheathing directly applied or 5-5-14 oc purlins.
 BOT CHORD Rigid ceiling directly applied or 10-0-0 oc bracing.

REACTIONS. (size) 1=0-3-8, 7=0-3-8
 Max Horz 1=270(LC 23)
 Max Uplift 1=225(LC 9), 7=237(LC 8)
 Max Grav 1=7977(LC 2), 7=8527(LC 2)

FORCES. (lb) - Max. Comp./Max. Ten. - All forces 250 (lb) or less except when shown.
 TOP CHORD 1-2=8698/296, 2-4=5745/316, 4-6=5744/316, 6-7=8803/299
 BOT CHORD 1-11=233/5962, 10-11=233/5971, 8-10=139/6041, 7-8=139/6032
 WEBS 4-10=299/7498, 6-10=2640/260, 6-8=42/3902, 2-10=2545/257, 2-11=37/3758

NOTES-

- 2-ply truss to be connected together with 10d (0.131"x3") nails as follows:
 Top chords connected as follows: 2x6 - 2 rows staggered at 0-9-0 oc.
 Bottom chords connected as follows: 2x8 - 2 rows staggered at 0-6-0 oc.
 Webs connected as follows: 2x4 - 1 row at 0-9-0 oc.
- All loads are considered equally applied to all plies, except if noted as front (F) or back (B) face in the LOAD CASE(S) section. Ply to ply connections have been provided to distribute only loads noted as (F) or (B), unless otherwise indicated.
- Unbalanced roof live loads have been considered for this design.
- Wind: ASCE 7-10; Vult=130mph Vasd=103mph; TCCL=6.0psf; BCDL=6.0psf; h=15ft; Cat. II; Exp C; Enclosed; MWFRS (envelope); Lumber DOL=1.60 plate grip DOL=1.60
- This truss has been designed for a 10.0 psf bottom chord live load nonconcurrent with any other live loads.
- * This truss has been designed for a live load of 30.0psf on the bottom chord in all areas where a rectangle 3-6-0 tall by 2-0-0 wide will fit between the bottom chord and any other members.
- Provide mechanical connection (by others) of truss to bearing plate capable of withstanding 100 lb uplift at joint(s) except (jt=lb) 1=225, 7=237.
- Hanger(s) or other connection device(s) shall be provided sufficient to support concentrated load(s) 1246 lb down and 39 lb up at 0-10-4, 1243 lb down and 42 lb up at 2-10-4, 1243 lb down and 42 lb up at 4-10-4, 1243 lb down and 42 lb up at 6-10-4, 1243 lb down and 42 lb up at 8-10-4, 1243 lb down and 42 lb up at 10-10-4, 1243 lb down and 42 lb up at 12-10-4, 1243 lb down and 42 lb up at 14-10-4, 1243 lb down and 42 lb up at 16-10-4, 1243 lb down and 42 lb up at 18-10-4, and 1243 lb down and 42 lb up at 20-4-4, and 1250 lb down and 35 lb up at 22-7-12 on bottom chord. The design/selection of such connection device(s) is the responsibility of others.

LOAD CASE(S) Standard

- Dead + Roof Live (balanced): Lumber Increase=1.15, Plate Increase=1.15

Continued on page 2



November 9, 2021

WARNING - Verify design parameters and READ NOTES ON THIS AND INCLUDED MITEK REFERENCE PAGE MII-7473 rev. 5/19/2020 BEFORE USE.
 Design valid for use only with MiTek® connectors. This design is based only upon parameters shown, and is for an individual building component, not a truss system. Before use, the building designer must verify the applicability of design parameters and properly incorporate this design into the overall building design. Bracing indicated is to prevent buckling of individual truss web and/or chord members only. Additional temporary and permanent bracing is always required for stability and to prevent collapse with possible personal injury and property damage. For general guidance regarding the fabrication, storage, delivery, erection and bracing of trusses and truss systems, see **ANSI/TPI1 Quality Criteria, DSB-89 and BCSI Building Component Safety Information** available from Truss Plate Institute, 2670 Crain Highway, Suite 203 Waldorf, MD 20601



818 Soundside Road
 Edenton, NC 27932

Job J0322-1269	Truss C1-GR	Truss Type COMMON GIRDER	Qty 1	Ply 2	Lot 5 Cypress Road E16391034 Job Reference (optional)
-------------------	----------------	-----------------------------	----------	-----------------	---

Comtech, Inc, Fayetteville, NC - 28314,

8.430 s Aug 16 2021 MiTek Industries, Inc. Mon Nov 8 13:12:40 2021 Page 2
ID:J6aSr?qB6etazEy6hKRSkZzPTZ_-08Y9JbWePU_bpu?a6771w2vITB?wBcg4vu3VEQyLENL

LOAD CASE(S) Standard

Uniform Loads (plf)

Vert: 1-4=-60, 4-7=-60, 1-7=-20

Concentrated Loads (lb)

Vert: 9=-969(B) 7=-976(B) 12=-972(B) 13=-969(B) 14=-969(B) 15=-969(B) 16=-969(B) 17=-969(B) 18=-969(B) 19=-969(B) 20=-969(B) 21=-969(B)

WARNING - Verify design parameters and READ NOTES ON THIS AND INCLUDED MITEK REFERENCE PAGE MII-7473 rev. 5/19/2020 BEFORE USE.

Design valid for use only with MiTek® connectors. This design is based only upon parameters shown, and is for an individual building component, not a truss system. Before use, the building designer must verify the applicability of design parameters and properly incorporate this design into the overall building design. Bracing indicated is to prevent buckling of individual truss web and/or chord members only. Additional temporary and permanent bracing is always required for stability and to prevent collapse with possible personal injury and property damage. For general guidance regarding the fabrication, storage, delivery, erection and bracing of trusses and truss systems, see

Safety Information available from Truss Plate Institute, 2670 Crain Highway, Suite 203 Waldorf, MD 20601 **ANSI/TPI1 Quality Criteria, DSB-89 and BCSI Building Component**



818 Soundside Road
Edenton, NC 27932

Job J0322-1269	Truss C1GE	Truss Type COMMON SUPPORTED GAB	Qty 1	Ply 1	Lot 5 Cypress Road Job Reference (optional)	E16391035
-------------------	---------------	------------------------------------	----------	----------	--	-----------

Comtech, Inc. Fayetteville, NC - 28314.

8.430 s Aug 16 2021 MiTek Industries, Inc. Mon Nov 8 13:12:38 2021 Page 1

ID:J6aSr?qB6etazEy6hKRskZzPTZ_-4mQPuvUOtstkaarB?a5Zrdq1aOP7ju1nRaaOAXyLENN

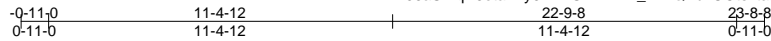

5x8 =

Scale = 1:71.8

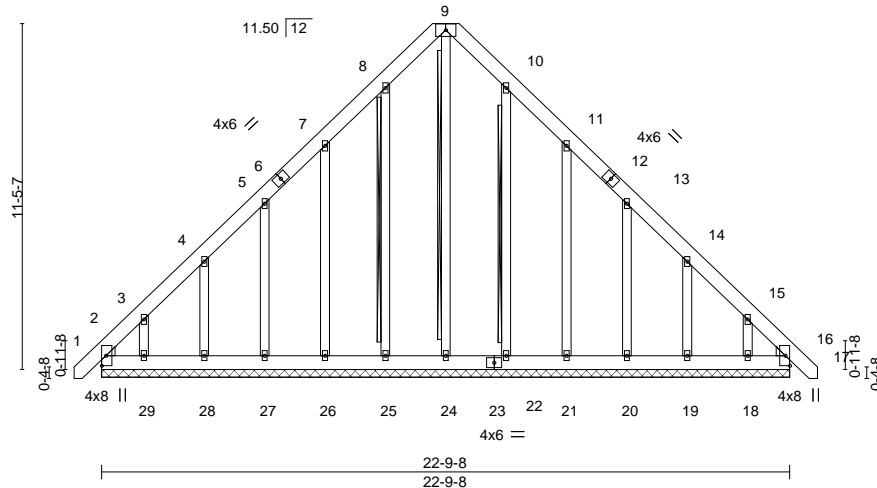

LOADING (psf)	SPACING-	2-0-0	CSI.	DEFL.	in (loc)	l/defl	L/d	PLATES	GRIP	
TCLL 20.0	Plate Grip DOL	1.15	TC 0.05	Vert(LL)	-0.00	16	n/r	120	MT20	244/190
TCDL 10.0	Lumber DOL	1.15	BC 0.03	Vert(CT)	-0.00	16	n/r	120		
BCLL 0.0 *	Rep Stress Incr	YES	WB 0.18	Horz(CT)	0.01	16	n/a	n/a		
BCDL 10.0	Code IRC2015/TPI2014		Matrix-S							
										Weight: 227 lb FT = 20%

LUMBER-

TOP CHORD 2x6 SP No.1
BOT CHORD 2x6 SP No.1
OTHERS 2x4 SP No.2
WEDGE

Left: 2x4 SP No.2 , Right: 2x4 SP No.2

BRACING-

TOP CHORD Structural wood sheathing directly applied or 6-0-0 oc purlins.
BOT CHORD Rigid ceiling directly applied or 10-0-0 oc bracing.
WEBS T-Brace: 2x4 SPF No.2 - 9-24, 8-25, 10-22
Fasten (2X) T and I braces to narrow edge of web with 10d (0.131"x3") nails, 6in o.c., with 3in minimum end distance.
Brace must cover 90% of web length.

REACTIONS.

All bearings 22-9-8.
(lb) - Max Horz 2=350(LC 10)
Max Uplift All uplift 100 lb or less at joint(s) 25, 22 except 2=170(LC 10), 26=147(LC 12), 27=130(LC 12), 28=137(LC 12), 29=210(LC 12), 21=150(LC 13), 20=130(LC 13), 19=136(LC 13), 18=200(LC 13), 16=103(LC 11)
Max Grav All reactions 250 lb or less at joint(s) 24, 25, 26, 27, 28, 29, 22, 21, 20, 19, 18 except 2=362(LC 12), 16=317(LC 13)

FORCES. (lb) - Max. Comp./Max. Ten. - All forces 250 (lb) or less except when shown.

TOP CHORD 2-3=506/298, 3-4=336/228, 14-15=285/175, 15-16=449/302
BOT CHORD 2-29=218/336, 28-29=220/337, 27-28=220/337, 26-27=221/337, 25-26=221/337, 24-25=221/337, 22-24=221/337, 21-22=221/337, 20-21=221/337, 19-20=220/337, 18-19=220/336, 16-18=218/335

NOTES-

- Unbalanced roof live loads have been considered for this design.
- Wind: ASCE 7-10; Vult=130mph Vasd=103mph; TCCL=6.0psf; BCDL=6.0psf; h=15ft; Cat. II; Exp C; Enclosed; MWFRS (envelope) gable end zone and C-C Exterior(2) zone; C-C for members and forces & MWFRS for reactions shown; Lumber DOL=1.60 plate grip DOL=1.60
- Truss designed for wind loads in the plane of the truss only. For studs exposed to wind (normal to the face), see Standard Industry Gable End Details as applicable, or consult qualified building designer as per ANSI/TPI 1.
- All plates are 2x4 MT20 unless otherwise indicated.
- Gable requires continuous bottom chord bearing.
- Gable studs spaced at 2-0-0 oc.
- This truss has been designed for a 10.0 psf bottom chord live load nonconcurrent with any other live loads.
- * This truss has been designed for a live load of 30.0psf on the bottom chord in all areas where a rectangle 3-6-0 tall by 2-0-0 wide will fit between the bottom chord and any other members.
- Provide mechanical connection (by others) of truss to bearing plate capable of withstanding 100 lb uplift at joint(s) 25, 22 except (jt=lb) 2=170, 26=147, 27=130, 28=137, 29=210, 21=150, 20=130, 19=136, 18=200, 16=103.
- Warning: Additional permanent and stability bracing for truss system (not part of this component design) is always required.



November 9, 2021

WARNING - Verify design parameters and READ NOTES ON THIS AND INCLUDED MITEK REFERENCE PAGE MII-7473 rev. 5/19/2020 BEFORE USE.

Design valid for use only with MiTek® connectors. This design is based only upon parameters shown, and is for an individual building component, not a truss system. Before use, the building designer must verify the applicability of design parameters and properly incorporate this design into the overall building design. Bracing indicated is to prevent buckling of individual truss web and/or chord members only. Additional temporary and permanent bracing is always required for stability and to prevent collapse with possible personal injury and property damage. For general guidance regarding the fabrication, storage, delivery, erection and bracing of trusses and truss systems, see **ANSI/TPI1 Quality Criteria, DSB-89 and BCSI Building Component Safety Information** available from Truss Plate Institute, 2670 Crain Highway, Suite 203 Waldorf, MD 20601



818 Soundside Road
Edenton, NC 27932

Job J0322-1269	Truss D1	Truss Type COMMON	Qty 5	Ply 1	Lot 5 Cypress Road Job Reference (optional)	E16391036
-------------------	-------------	----------------------	----------	----------	--	-----------

Comtech, Inc., Fayetteville, NC - 28314,

8.430 s Aug 16 2021 MiTek Industries, Inc. Mon Nov 8 13:12:41 2021 Page 1
ID:J6aSr?qB6etazEy6hKRskZzPTZ_-UL6XXxXGAn6SR2ZmgifGTFSV8bPHwHcD8Yo2nsyLENK

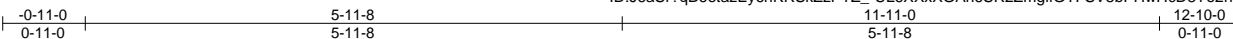

Scale: 1/2"=1'

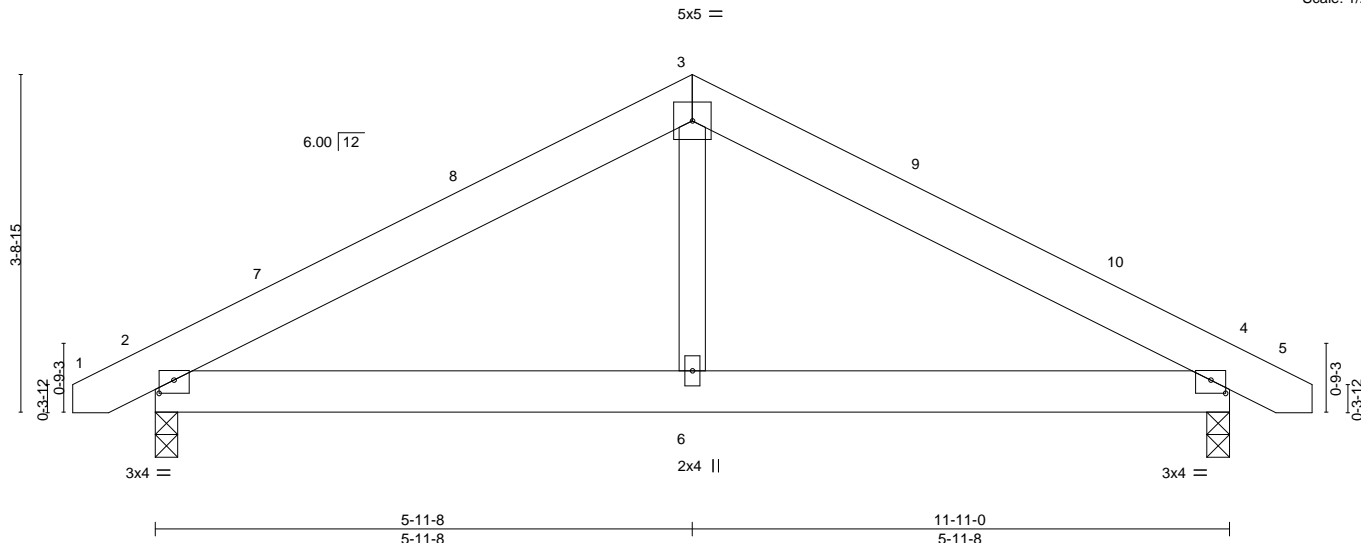

Plate Offsets (X,Y)--	[2:0-2-0,0-1-12], [4:0-2-0,0-1-12]
-----------------------	------------------------------------

LOADING (psf)	SPACING-	2-0-0	CSI.	DEFL.	in	(loc)	l/defl	L/d	PLATES	GRIP
TCLL 20.0	Plate Grip DOL	1.15	TC 0.16	Vert(LL)	0.02	2-6	>999	240	MT20	244/190
TCDL 10.0	Lumber DOL	1.15	BC 0.13	Vert(CT)	-0.02	2-6	>999	240		
BCLL 0.0 *	Rep Stress Incr	YES	WB 0.06	Horz(CT)	0.01	4	n/a	n/a		
BCDL 10.0	Code IRC2015/TPI2014		Matrix-S						Weight: 69 lb	FT = 20%

LUMBER-
TOP CHORD 2x6 SP No.1
BOT CHORD 2x6 SP No.1
WEBS 2x4 SP No.2

BRACING-
TOP CHORD Structural wood sheathing directly applied or 6-0-0 oc purlins.
BOT CHORD Rigid ceiling directly applied or 10-0-0 oc bracing.

REACTIONS. (size) 2=0-3-0, 4=0-3-0
Max Horz 2=43(LC 11)
Max Uplift 2=106(LC 9), 4=106(LC 8)
Max Grav 2=517(LC 1), 4=517(LC 1)

FORCES. (lb) - Max. Comp./Max. Ten. - All forces 250 (lb) or less except when shown.
TOP CHORD 2-3=626/654, 3-4=626/654
BOT CHORD 2-6=466/475, 4-6=466/475
WEBS 3-6=364/279

- NOTES-**
- Unbalanced roof live loads have been considered for this design.
 - Wind: ASCE 7-10; Vult=130mph Vasd=103mph; TCDL=6.0psf; BCDL=6.0psf; h=15ft; Cat. II; Exp C; Enclosed; MWFRS (envelope) and C-C Exterior(2) -0-8-10 to 3-8-3, Interior(1) 3-8-3 to 5-11-8, Exterior(2) 5-11-8 to 10-4-5, Interior(1) 10-4-5 to 12-7-10 zone; porch left and right exposed; C-C for members and forces & MWFRS for reactions shown; Lumber DOL=1.60 plate grip DOL=1.60
 - This truss has been designed for a 10.0 psf bottom chord live load nonconcurrent with any other live loads.
 - * This truss has been designed for a live load of 30.0psf on the bottom chord in all areas where a rectangle 3-6-0 tall by 2-0-0 wide will fit between the bottom chord and any other members.
 - Provide mechanical connection (by others) of truss to bearing plate capable of withstanding 100 lb uplift at joint(s) except (jt=lb) 2=106, 4=106.



November 9, 2021

WARNING - Verify design parameters and READ NOTES ON THIS AND INCLUDED MITEK REFERENCE PAGE MII-7473 rev. 5/19/2020 BEFORE USE.
Design valid for use only with MiTek® connectors. This design is based only upon parameters shown, and is for an individual building component, not a truss system. Before use, the building designer must verify the applicability of design parameters and properly incorporate this design into the overall building design. Bracing indicated is to prevent buckling of individual truss web and/or chord members only. Additional temporary and permanent bracing is always required for stability and to prevent collapse with possible personal injury and property damage. For general guidance regarding the fabrication, storage, delivery, erection and bracing of trusses and truss systems, see **ANSI/TPI1 Quality Criteria, DSB-89 and BCSI Building Component Safety Information** available from Truss Plate Institute, 2670 Crain Highway, Suite 203 Waldorf, MD 20601



818 Soundside Road
Edenton, NC 27932

Job J0322-1269	Truss D1GE	Truss Type GABLE	Qty 1	Ply 1	Lot 5 Cypress Road	E16391037
-------------------	---------------	---------------------	----------	----------	--------------------	-----------

Comtech, Inc. Fayetteville, NC - 28314,

8.430 s Aug 16 2021 MiTek Industries, Inc. Mon Nov 8 13:12:42 2021 Page 1

ID:J6aSr?qB6etazEy6hKRSkZzPTZ_yXfvkGXvx5EJ3C8yEQAV?T?hV?IPfksMMCYcJyLENJ

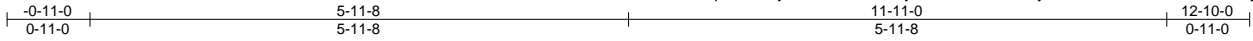

Scale: 1/2"=1'

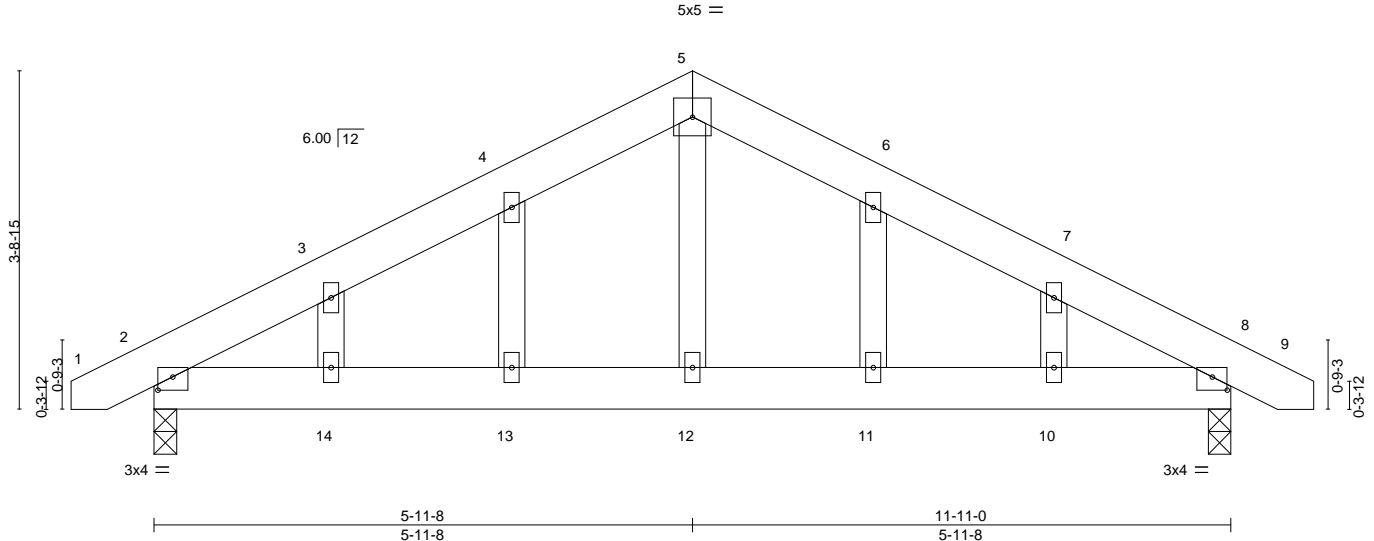

Plate Offsets (X,Y)-- [2:0-2-0,0-1-12], [8:0-2-0,0-1-12]

LOADING (psf)	SPACING-	CSI.	DEFL.	PLATES	GRIP
TCLL 20.0	2-0-0	TC 0.12	in (loc) l/defl L/d	MT20	244/190
TCDL 10.0	Plate Grip DOL 1.15	BC 0.14	Vert(LL) -0.01 13-14 >999 360		
BCLL 0.0 *	Lumber DOL 1.15	WB 0.06	Vert(CT) -0.02 13-14 >999 240		
BCDL 10.0	Rep Stress Incr YES	Matrix-S	Horz(CT) 0.01 8 n/a n/a		
	Code IRC2015/TPI2014		Wind(LL) 0.02 10-11 >999 240	Weight: 77 lb	FT = 20%

LUMBER-
TOP CHORD 2x6 SP No.1
BOT CHORD 2x6 SP No.1
WEBS 2x4 SP No.2
OTHERS 2x4 SP No.2

BRACING-
TOP CHORD Structural wood sheathing directly applied or 6-0-0 oc purlins.
BOT CHORD Rigid ceiling directly applied or 10-0-0 oc bracing.

REACTIONS. (size) 2=0-3-0, 8=0-3-0
Max Horz 2=68(LC 12)
Max Uplift 2=137(LC 9), 8=137(LC 8)
Max Grav 2=517(LC 1), 8=517(LC 1)

FORCES. (lb) - Max. Comp./Max. Ten. - All forces 250 (lb) or less except when shown.
TOP CHORD 2-3=623/674, 3-4=555/669, 4-5=530/694, 5-6=530/694, 6-7=555/669, 7-8=623/674
BOT CHORD 2-14=490/476, 13-14=490/476, 12-13=490/476, 11-12=490/476, 10-11=490/476,
8-10=490/476
WEBS 5-12=372/227

- NOTES-**
- Unbalanced roof live loads have been considered for this design.
 - Wind: ASCE 7-10; Vult=130mph Vasd=103mph; TCCL=6.0psf; BCCL=6.0psf; h=15ft; Cat. II; Exp C; Enclosed; MWFRS (envelope) gable end zone and C-C Exterior(2) zone; porch left and right exposed;C-C for members and forces & MWFRS for reactions shown; Lumber DOL=1.60 plate grip DOL=1.60
 - Truss designed for wind loads in the plane of the truss only. For studs exposed to wind (normal to the face), see Standard Industry Gable End Details as applicable, or consult qualified building designer as per ANSI/TPI 1.
 - All plates are 2x4 MT20 unless otherwise indicated.
 - Gable studs spaced at 2-0-0 oc.
 - This truss has been designed for a 10.0 psf bottom chord live load nonconcurrent with any other live loads.
 - * This truss has been designed for a live load of 30.0psf on the bottom chord in all areas where a rectangle 3-6-0 tall by 2-0-0 wide will fit between the bottom chord and any other members.
 - Provide mechanical connection (by others) of truss to bearing plate capable of withstanding 100 lb uplift at joint(s) except (jt=lb) 2=137, 8=137.



November 9,2021

WARNING - Verify design parameters and READ NOTES ON THIS AND INCLUDED MITEK REFERENCE PAGE MII-7473 rev. 5/19/2020 BEFORE USE.
Design valid for use only with MiTek® connectors. This design is based only upon parameters shown, and is for an individual building component, not a truss system. Before use, the building designer must verify the applicability of design parameters and properly incorporate this design into the overall building design. Bracing indicated is to prevent buckling of individual truss web and/or chord members only. Additional temporary and permanent bracing is always required for stability and to prevent collapse with possible personal injury and property damage. For general guidance regarding the fabrication, storage, delivery, erection and bracing of trusses and truss systems, see **ANSI/TPI1 Quality Criteria, DSB-89 and BCSI Building Component Safety Information** available from Truss Plate Institute, 2670 Crain Highway, Suite 203 Waldorf, MD 20601



818 Soundside Road
Edenton, NC 27932

Job	Truss	Truss Type	Qty	Ply	Lot 5 Cypress Road	E16391038
J0322-1269	M1	MONOPITCH	11	1	Job Reference (optional)	

Comtech, Inc. Fayetteville, NC - 28314,

8.430 s Aug 16 2021 MiTek Industries, Inc. Mon Nov 8 13:12:42 2021 Page 1
 ID:J6aSr?qB6etazEy6hKRSkZzPTZ_-yXfvkGXvx5EJ3C8yEQAV?T?gN?mfkrMMCyCjJyLENJ

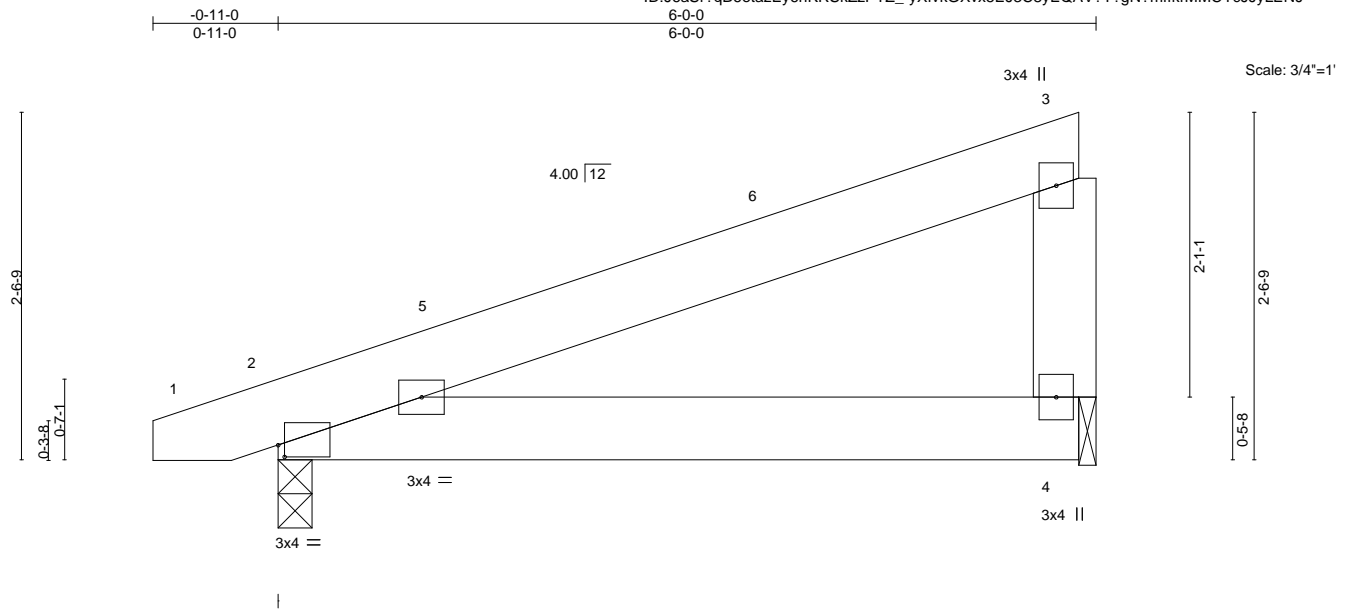

Plate Offsets (X,Y)-- [2:0-0-9,0-1-1]

LOADING (psf)	SPACING-	CSI.	DEFL.	in (loc)	I/defl	L/d	PLATES	GRIP
TCLL 20.0	2-0-0	TC 0.19	Vert(LL)	-0.01	2-4	>999	MT20	244/190
TCDL 10.0	Plate Grip DOL 1.15	BC 0.12	Vert(CT)	-0.03	2-4	>999		
BCLL 0.0 *	Lumber DOL 1.15	WB 0.00	Horz(CT)	0.00		n/a		
BCDL 10.0	Rep Stress Incr YES	Matrix-P	Wind(LL)	0.03	2-4	>999		
	Code IRC2015/TPI2014						Weight: 34 lb	FT = 20%

LUMBER-
 TOP CHORD 2x6 SP No.1
 BOT CHORD 2x6 SP No.1
 WEBS 2x6 SP No.1

BRACING-
 TOP CHORD Structural wood sheathing directly applied or 6-0-0 oc purlins, except end verticals.
 BOT CHORD Rigid ceiling directly applied or 10-0-0 oc bracing.

REACTIONS. (size) 2=0-3-0, 4=0-1-8
 Max Horz 2=71(LC 8)
 Max Uplift 2=104(LC 8), 4=97(LC 8)
 Max Grav 2=274(LC 1), 4=223(LC 1)

FORCES. (lb) - Max. Comp./Max. Ten. - All forces 250 (lb) or less except when shown.

NOTES-

- 1) Wind: ASCE 7-10; Vult=130mph Vasd=103mph; TCDL=6.0psf; BCDL=6.0psf; h=15ft; Cat. II; Exp C; Enclosed; MWFRS (envelope) and C-C Exterior(2) -0-7-9 to 3-9-4, Interior(1) 3-9-4 to 5-9-4 zone; porch left exposed; C-C for members and forces & MWFRS for reactions shown; Lumber DOL=1.60 plate grip DOL=1.60
- 2) This truss has been designed for a 10.0 psf bottom chord live load nonconcurrent with any other live loads.
- 3) * This truss has been designed for a live load of 30.0psf on the bottom chord in all areas where a rectangle 3-6-0 tall by 2-0-0 wide will fit between the bottom chord and any other members.
- 4) Bearing at joint(s) 4 considers parallel to grain value using ANSI/TPI 1 angle to grain formula. Building designer should verify capacity of bearing surface.
- 5) Provide mechanical connection (by others) of truss to bearing plate at joint(s) 4.
- 6) Provide mechanical connection (by others) of truss to bearing plate capable of withstanding 100 lb uplift at joint(s) 4 except (jt=lb) 2=104.



November 9, 2021

WARNING - Verify design parameters and READ NOTES ON THIS AND INCLUDED MITEK REFERENCE PAGE MII-7473 rev. 5/19/2020 BEFORE USE.
 Design valid for use only with MiTek® connectors. This design is based only upon parameters shown, and is for an individual building component, not a truss system. Before use, the building designer must verify the applicability of design parameters and properly incorporate this design into the overall building design. Bracing indicated is to prevent buckling of individual truss web and/or chord members only. Additional temporary and permanent bracing is always required for stability and to prevent collapse with possible personal injury and property damage. For general guidance regarding the fabrication, storage, delivery, erection and bracing of trusses and truss systems, see ANSI/TPI1 Quality Criteria, DSB-89 and BCSI Building Component Safety Information available from Truss Plate Institute, 2670 Crain Highway, Suite 203 Waldorf, MD 20601



818 Soundside Road
 Edenton, NC 27932

Job	Truss	Truss Type	Qty	Ply	Lot 5 Cypress Road	E16391039
J0322-1269	M1GE	GABLE	1	1	Job Reference (optional)	

Comtech, Inc. Fayetteville, NC - 28314,

8.430 s Aug 16 2021 MiTek Industries, Inc. Mon Nov 8 13:12:43 2021 Page 1
 ID:J6aSr?qB6etazEy6hKRSkZzPTZ_-QjDlycYXiPMAgJ8o7hkYgXsbP5KOBuWbrH9rlyLENI
 6-0-0
 6-0-0

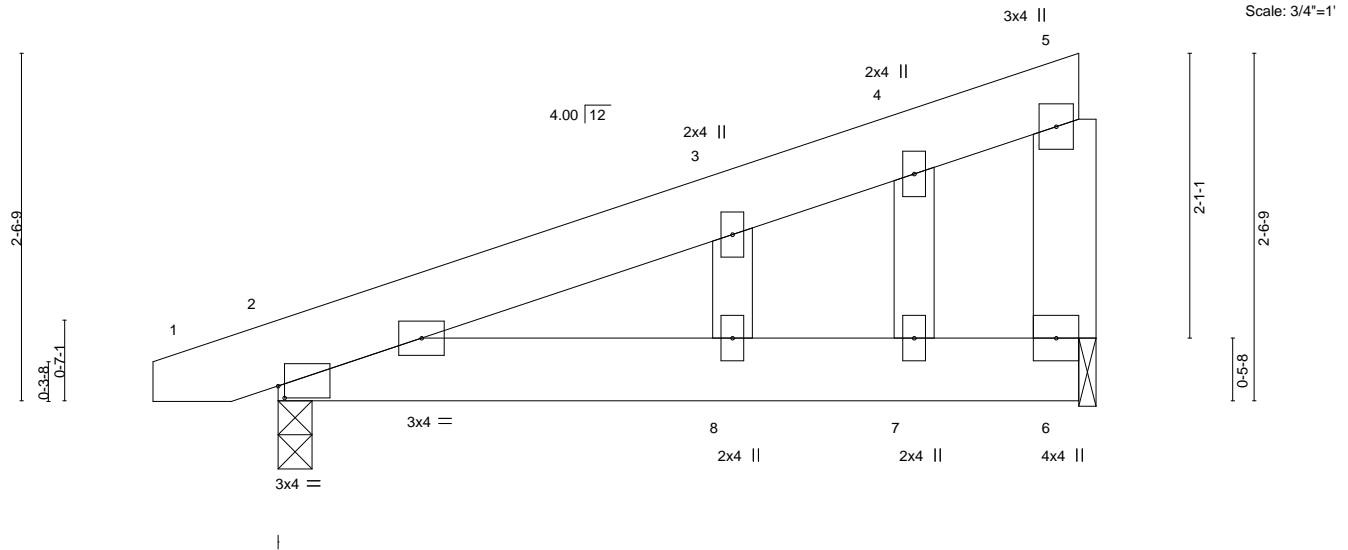

Plate Offsets (X,Y)-- [2:0-0-9,0-1-1]

LOADING (psf)	SPACING-	CSI.	DEFL.	PLATES	GRIP
TCLL 20.0	2-0-0	TC 0.09	in (loc) l/defl L/d	MT20	244/190
TCDL 10.0	Plate Grip DOL 1.15	BC 0.10	Vert(LL) 0.02 2-8 >999 240		
BCLL 0.0 *	Lumber DOL 1.15	WB 0.01	Vert(CT) -0.02 8 >999 240		
BCDL 10.0	Rep Stress Incr YES	Matrix-S	Horz(CT) -0.00 6 n/a n/a		
	Code IRC2015/TPI2014			Weight: 37 lb	FT = 20%

LUMBER-
 TOP CHORD 2x6 SP No.1
 BOT CHORD 2x6 SP No.1
 WEBS 2x6 SP No.1
 OTHERS 2x4 SP No.2

BRACING-
 TOP CHORD Structural wood sheathing directly applied or 6-0-0 oc purlins, except end verticals.
 BOT CHORD Rigid ceiling directly applied or 10-0-0 oc bracing.

REACTIONS. (size) 2=0-3-0, 6=0-1-8
 Max Horz 2=101(LC 8)
 Max Uplift 2=151(LC 8), 6=142(LC 8)
 Max Grav 2=274(LC 1), 6=223(LC 1)

FORCES. (lb) - Max. Comp./Max. Ten. - All forces 250 (lb) or less except when shown.

- NOTES-**
- 1) Wind: ASCE 7-10; Vult=130mph Vasd=103mph; TCDL=6.0psf; BCDL=6.0psf; h=15ft; Cat. II; Exp C; Enclosed; MWFRS (envelope) gable end zone and C-C Exterior(2) zone; porch left exposed;C-C for members and forces & MWFRS for reactions shown; Lumber DOL=1.60 plate grip DOL=1.60
 - 2) Truss designed for wind loads in the plane of the truss only. For studs exposed to wind (normal to the face), see Standard Industry Gable End Details as applicable, or consult qualified building designer as per ANSI/TPI 1.
 - 3) Gable studs spaced at 1-4-0 oc.
 - 4) This truss has been designed for a 10.0 psf bottom chord live load nonconcurrent with any other live loads.
 - 5) * This truss has been designed for a live load of 30.0psf on the bottom chord in all areas where a rectangle 3-6-0 tall by 2-0-0 wide will fit between the bottom chord and any other members.
 - 6) Bearing at joint(s) 6 considers parallel to grain value using ANSI/TPI 1 angle to grain formula. Building designer should verify capacity of bearing surface.
 - 7) Provide mechanical connection (by others) of truss to bearing plate at joint(s) 6.
 - 8) Provide mechanical connection (by others) of truss to bearing plate capable of withstanding 100 lb uplift at joint(s) except (jt=lb) 2=151, 6=142.



November 9, 2021

WARNING - Verify design parameters and READ NOTES ON THIS AND INCLUDED MITEK REFERENCE PAGE MII-7473 rev. 5/19/2020 BEFORE USE.
 Design valid for use only with MiTek® connectors. This design is based only upon parameters shown, and is for an individual building component, not a truss system. Before use, the building designer must verify the applicability of design parameters and properly incorporate this design into the overall building design. Bracing indicated is to prevent buckling of individual truss web and/or chord members only. Additional temporary and permanent bracing is always required for stability and to prevent collapse with possible personal injury and property damage. For general guidance regarding the fabrication, storage, delivery, erection and bracing of trusses and truss systems, see **ANSI/TPI1 Quality Criteria, DSB-89 and BCSI Building Component Safety Information** available from Truss Plate Institute, 2670 Crain Highway, Suite 203 Waldorf, MD 20601

TRENCO
 818 Soundside Road
 Edenton, NC 27932

Job	Truss	Truss Type	Qty	Ply	Lot 5 Cypress Road	E16391040
J0322-1269	PB	Piggyback	24	1	Job Reference (optional)	

Comtech, Inc, Fayetteville, NC - 28314,

8.430 s Aug 16 2021 MiTek Industries, Inc. Mon Nov 8 13:12:44 2021 Page 1
ID:J6aSr?qB6etazEy6hKRSkZzPTZ_-uvng9yZ9TIU11VILLrCz5u4?doRi7evfqV1jNByLENH

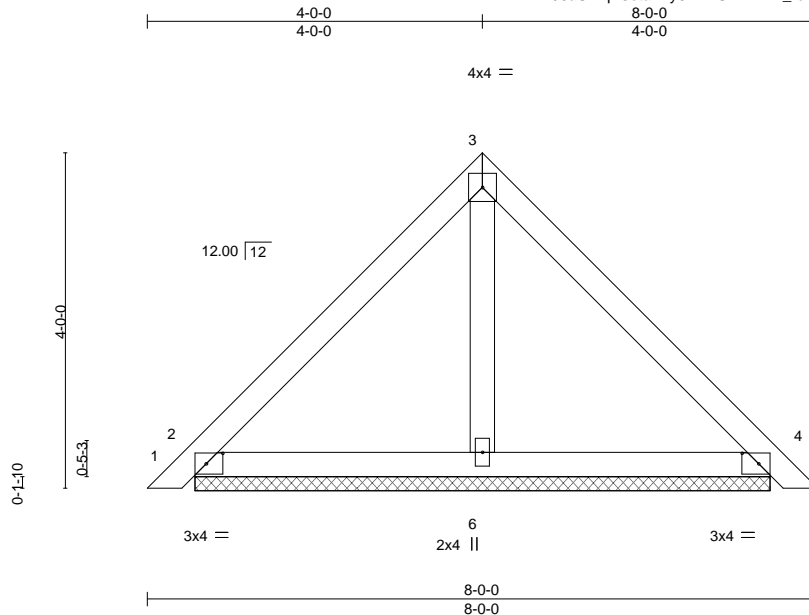

Scale = 1:25.9

Plate Offsets (X,Y)-- [2:0-2-6,0-1-8], [4:0-2-6,0-1-8]

LOADING (psf)	SPACING-	CSI.	DEFL.	in (loc)	l/defl	L/d	PLATES	GRIP
TCLL 20.0	2-0-0	TC 0.20	Vert(LL)	0.01	5	n/r	MT20	244/190
TCDL 10.0	Plate Grip DOL 1.15	BC 0.09	Vert(CT)	0.01	5	n/r		
BCLL 0.0 *	Lumber DOL 1.15	WB 0.03	Horz(CT)	0.00	4	n/a		
BCDL 10.0	Rep Stress Incr YES	Matrix-P					Weight: 32 lb	FT = 20%
	Code IRC2015/TPI2014							

LUMBER-
 TOP CHORD 2x4 SP No.1
 BOT CHORD 2x4 SP No.1
 OTHERS 2x4 SP No.2

BRACING-
 TOP CHORD Structural wood sheathing directly applied or 6'-0-0 oc purlins.
 BOT CHORD Rigid ceiling directly applied or 10'-0-0 oc bracing.

REACTIONS. (size) 2=6-10-6, 4=6-10-6, 6=6-10-6
 Max Horz 2=114(LC 10)
 Max Uplift 2=65(LC 13), 4=71(LC 13)
 Max Grav 2=190(LC 1), 4=190(LC 1), 6=214(LC 3)

FORCES. (lb) - Max. Comp./Max. Ten. - All forces 250 (lb) or less except when shown.

NOTES-

- 1) Unbalanced roof live loads have been considered for this design.
- 2) Wind: ASCE 7-10; Vult=130mph Vasd=103mph; TCDL=6.0psf; BCDL=6.0psf; h=15ft; Cat. II; Exp C; Enclosed; MWFRS (envelope) gable end zone and C-C Exterior(2) zone; C-C for members and forces & MWFRS for reactions shown; Lumber DOL=1.60 plate grip DOL=1.60
- 3) Gable requires continuous bottom chord bearing.
- 4) This truss has been designed for a 10.0 psf bottom chord live load nonconcurrent with any other live loads.
- 5) * This truss has been designed for a live load of 30.0psf on the bottom chord in all areas where a rectangle 3'-6-0 tall by 2'-0-0 wide will fit between the bottom chord and any other members.
- 6) Provide mechanical connection (by others) of truss to bearing plate capable of withstanding 100 lb uplift at joint(s) 2, 4.
- 7) See Standard Industry Piggyback Truss Connection Detail for Connection to base truss as applicable, or consult qualified building designer.



November 9, 2021

WARNING - Verify design parameters and READ NOTES ON THIS AND INCLUDED MITTEK REFERENCE PAGE MII-7473 rev. 5/19/2020 BEFORE USE.
 Design valid for use only with MiTek® connectors. This design is based only upon parameters shown, and is for an individual building component, not a truss system. Before use, the building designer must verify the applicability of design parameters and properly incorporate this design into the overall building design. Bracing indicated is to prevent buckling of individual truss web and/or chord members only. Additional temporary and permanent bracing is always required for stability and to prevent collapse with possible personal injury and property damage. For general guidance regarding the fabrication, storage, delivery, erection and bracing of trusses and truss systems, see **ANSI/TPI1 Quality Criteria, DSB-89 and BCSI Building Component Safety Information** available from Truss Plate Institute, 2670 Crain Highway, Suite 203 Waldorf, MD 20601



818 Soundside Road
 Edenton, NC 27932

Job J0322-1269	Truss V1	Truss Type VALLEY	Qty 1	Ply 1	Lot 5 Cypress Road Job Reference (optional)	E16391041
-------------------	-------------	----------------------	----------	----------	--	-----------

Comtech, Inc, Fayetteville, NC - 28314,

8.430 s Aug 16 2021 MiTek Industries, Inc. Mon Nov 8 13:12:45 2021 Page 1

ID:J6aSr?qB6etazEy6hKRSkZzPTZ_-N6L2MlanE0cuwftXvYjCd5dB6CmNs2Jp29mGwdyLENG

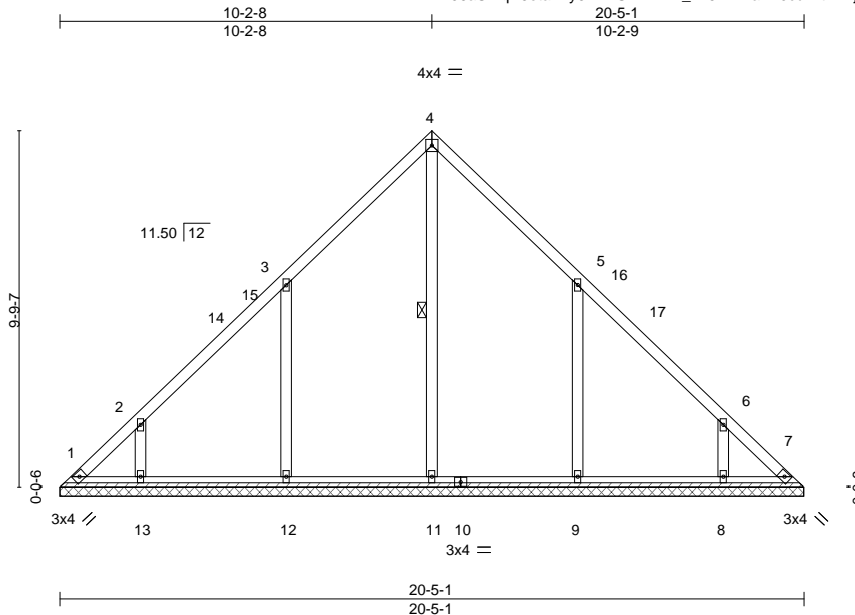

Scale = 1:59.5

Plate Offsets (X,Y)-- [5:0-0-0,0-0-0], [6:0-0-0,0-0-0]

LOADING (psf)	SPACING-	2-0-0	CSI.	DEFL.	in (loc)	l/defl	L/d	PLATES	GRIP	
TCLL 20.0	Plate Grip DOL	1.15	TC 0.16	Vert(LL)	n/a	-	n/a	999	MT20	244/190
TCDL 10.0	Lumber DOL	1.15	BC 0.19	Vert(CT)	n/a	-	n/a	999		
BCLL 0.0 *	Rep Stress Incr	YES	WB 0.21	Horz(CT)	0.00	7	n/a	n/a		
BCDL 10.0	Code IRC2015/TPI2014		Matrix-S						Weight: 105 lb	FT = 20%

LUMBER-
 TOP CHORD 2x4 SP No.1
 BOT CHORD 2x4 SP No.1
 OTHERS 2x4 SP No.2

BRACING-
 TOP CHORD Structural wood sheathing directly applied or 6'-0" oc purlins.
 BOT CHORD Rigid ceiling directly applied or 10'-0" oc bracing.
 WEBS 1 Row at midpt 4-11

REACTIONS. All bearings 20-5-1.
 (lb) - Max Horz 1=226(LC 9)
 Max Uplift All uplift 100 lb or less at joint(s) 1, 7 except 12=173(LC 12), 13=126(LC 12), 9=173(LC 13), 8=126(LC 13)
 Max Grav All reactions 250 lb or less at joint(s) 1, 7 except 11=440(LC 22), 12=486(LC 19), 13=285(LC 19), 9=485(LC 20), 8=285(LC 20)

FORCES. (lb) - Max. Comp./Max. Ten. - All forces 250 (lb) or less except when shown.
 WEBS 3-12=-393/294, 2-13=-299/243, 5-9=-393/294, 6-8=-299/243

- NOTES-**
- Unbalanced roof live loads have been considered for this design.
 - Wind: ASCE 7-10; Vult=130mph Vasd=103mph; TCCL=6.0psf; BCCL=6.0psf; h=15ft; Cat. II; Exp C; Enclosed; MWFRS (envelope) and C-C Exterior(2) 0-4-6 to 4-9-2, Interior(1) 4-9-2 to 10-2-8, Exterior(2) 10-2-8 to 14-7-5, Interior(1) 14-7-5 to 20-0-11 zone;C-C for members and forces & MWFRS for reactions shown; Lumber DOL=1.60 plate grip DOL=1.60
 - All plates are 2x4 MT20 unless otherwise indicated.
 - Gable requires continuous bottom chord bearing.
 - This truss has been designed for a 10.0 psf bottom chord live load nonconcurrent with any other live loads.
 - * This truss has been designed for a live load of 30.0psf on the bottom chord in all areas where a rectangle 3'-6" tall by 2'-0" wide will fit between the bottom chord and any other members, with BCCL = 10.0psf.
 - Provide mechanical connection (by others) of truss to bearing plate capable of withstanding 100 lb uplift at joint(s) 1, 7 except (jt=lb) 12=173, 13=126, 9=173, 8=126.



November 9,2021

WARNING - Verify design parameters and READ NOTES ON THIS AND INCLUDED MITTEK REFERENCE PAGE MII-7473 rev. 5/19/2020 BEFORE USE.
 Design valid for use only with MiTek® connectors. This design is based only upon parameters shown, and is for an individual building component, not a truss system. Before use, the building designer must verify the applicability of design parameters and properly incorporate this design into the overall building design. Bracing indicated is to prevent buckling of individual truss web and/or chord members only. Additional temporary and permanent bracing is always required for stability and to prevent collapse with possible personal injury and property damage. For general guidance regarding the fabrication, storage, delivery, erection and bracing of trusses and truss systems, see **ANSI/TPI1 Quality Criteria, DSB-89 and BCSI Building Component Safety Information** available from Truss Plate Institute, 2670 Crain Highway, Suite 203 Waldorf, MD 20601



818 Soundside Road
 Edenton, NC 27932

Job J0322-1269	Truss V2	Truss Type VALLEY	Qty 1	Ply 1	Lot 5 Cypress Road Job Reference (optional)	E16391042
-------------------	-------------	----------------------	----------	----------	--	-----------

Comtech, Inc. Fayetteville, NC - 28314,

8.430 s Aug 16 2021 MiTek Industries, Inc. Mon Nov 8 13:12:46 2021 Page 1
ID:J6aSr?qB6etazEy6hKRSkZzPTZ_-rlvQaeap?KklXpSjTFERAJ9Mfc6ebWmyHpWpS4yLENF

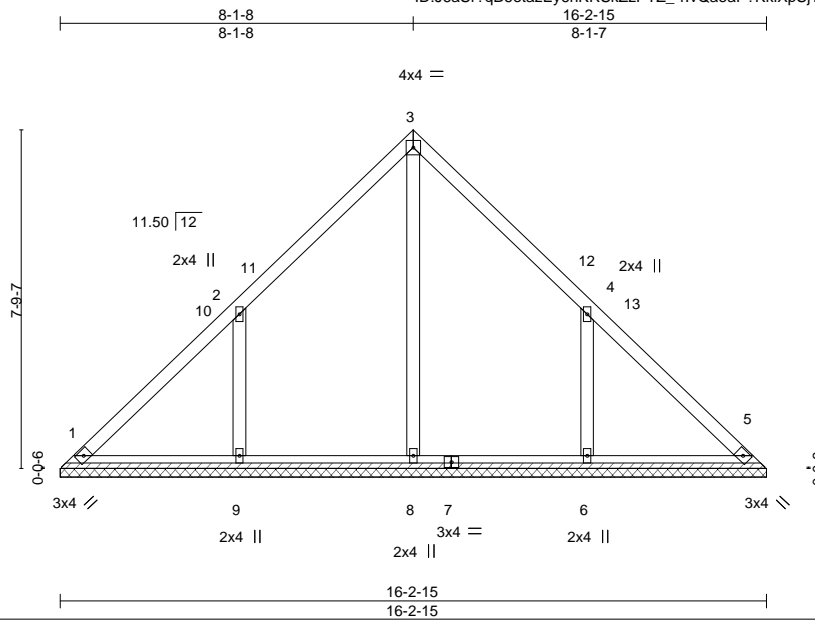

Scale = 1:49.9

Plate Offsets (X,Y)-- [4:0-0-0,0-0-0]

LOADING (psf)	SPACING-	2-0-0	CSI.	DEFL.	in	(loc)	l/defl	L/d	PLATES	GRIP
TCLL 20.0	Plate Grip DOL	1.15	TC 0.17	Vert(LL)	n/a	-	n/a	999	MT20	244/190
TCDL 10.0	Lumber DOL	1.15	BC 0.19	Vert(CT)	n/a	-	n/a	999		
BCLL 0.0 *	Rep Stress Incr	YES	WB 0.13	Horz(CT)	0.00	5	n/a	n/a		
BCDL 10.0	Code IRC2015/TPI2014		Matrix-S						Weight: 77 lb	FT = 20%

LUMBER-
TOP CHORD 2x4 SP No.1
BOT CHORD 2x4 SP No.1
OTHERS 2x4 SP No.2

BRACING-
TOP CHORD Structural wood sheathing directly applied or 6-0-0 oc purlins.
BOT CHORD Rigid ceiling directly applied or 10-0-0 oc bracing.

REACTIONS. All bearings 16-2-15.
(lb) - Max Horz 1=178(LC 8)
Max Uplift All uplift 100 lb or less at joint(s) 1 except 9=182(LC 12), 6=182(LC 13)
Max Grav All reactions 250 lb or less at joint(s) 1, 5 except 8=418(LC 22), 9=503(LC 19), 6=503(LC 20)

FORCES. (lb) - Max. Comp./Max. Ten. - All forces 250 (lb) or less except when shown.
WEBS 2-9=-406/302, 4-6=-406/302

- NOTES-**
- Unbalanced roof live loads have been considered for this design.
 - Wind: ASCE 7-10; Vult=130mph Vasd=103mph; TCCL=6.0psf; BCDL=6.0psf; h=15ft; Cat. II; Exp C; Enclosed; MWFRS (envelope) and C-C Exterior(2) 0-4-6 to 4-9-2, Interior(1) 4-9-2 to 8-1-8, Exterior(2) 8-1-8 to 12-6-4, Interior(1) 12-6-4 to 15-10-9 zone;C-C for members and forces & MWFRS for reactions shown; Lumber DOL=1.60 plate grip DOL=1.60
 - Gable requires continuous bottom chord bearing.
 - This truss has been designed for a 10.0 psf bottom chord live load nonconcurrent with any other live loads.
 - * This truss has been designed for a live load of 30.0psf on the bottom chord in all areas where a rectangle 3-6-0 tall by 2-0-0 wide will fit between the bottom chord and any other members, with BCDL = 10.0psf.
 - Provide mechanical connection (by others) of truss to bearing plate capable of withstanding 100 lb uplift at joint(s) 1 except (jt=lb) 9=182, 6=182.



November 9,2021

WARNING - Verify design parameters and READ NOTES ON THIS AND INCLUDED MITEK REFERENCE PAGE MII-7473 rev. 5/19/2020 BEFORE USE.
Design valid for use only with MiTek® connectors. This design is based only upon parameters shown, and is for an individual building component, not a truss system. Before use, the building designer must verify the applicability of design parameters and properly incorporate this design into the overall building design. Bracing indicated is to prevent buckling of individual truss web and/or chord members only. Additional temporary and permanent bracing is always required for stability and to prevent collapse with possible personal injury and property damage. For general guidance regarding the fabrication, storage, delivery, erection and bracing of trusses and truss systems, see **ANSI/TPI1 Quality Criteria, DSB-89 and BCSI Building Component Safety Information** available from Truss Plate Institute, 2670 Crain Highway, Suite 203 Waldorf, MD 20601



818 Soundside Road
Edenton, NC 27932

Job J0322-1269	Truss V3	Truss Type VALLEY	Qty 1	Ply 1	Lot 5 Cypress Road Job Reference (optional)	E16391043
-------------------	-------------	----------------------	----------	----------	--	-----------

Comtech, Inc, Fayetteville, NC - 28314,

8.430 s Aug 16 2021 MiTek Industries, Inc. Mon Nov 8 13:12:47 2021 Page 1
ID:J6aSr?qB6etazEy6hKRSkZzPTZ_-JUTon_b1mdsc9z1w1zlgIWiXz0TMK_y6WTFN_WyLENE

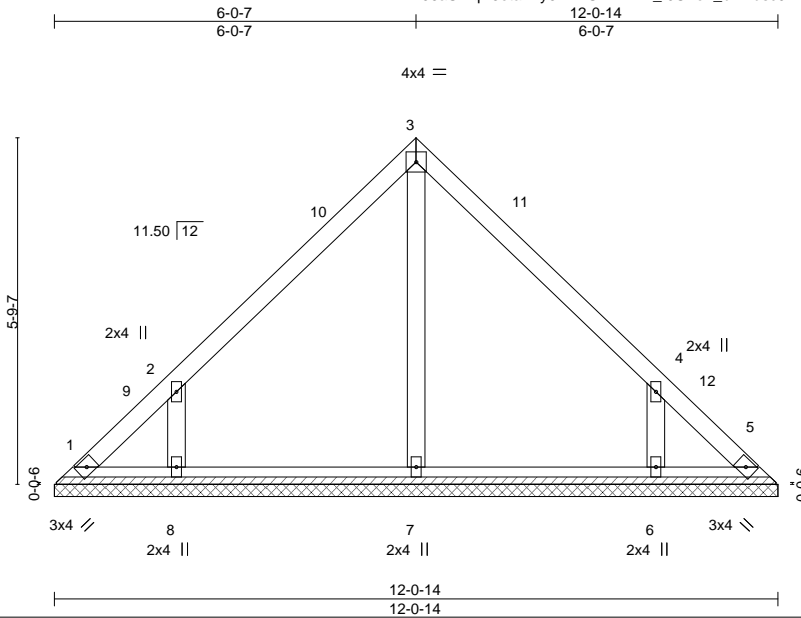

Scale = 1:36.2

Plate Offsets (X,Y)-- [4:0-0-0,0-0-0]

LOADING (psf)	SPACING-	CSI.	DEFL.	PLATES	GRIP
TCLL 20.0	2-0-0	TC 0.13	in (loc) l/defl L/d	MT20	244/190
TCDL 10.0	Plate Grip DOL 1.15	BC 0.09	Vert(LL) n/a - n/a 999		
BCLL 0.0 *	Lumber DOL 1.15	WB 0.07	Vert(CT) n/a - n/a 999		
BCDL 10.0	Rep Stress Incr YES	Matrix-S	Horz(CT) 0.00 5 n/a n/a		
	Code IRC2015/TPI2014			Weight: 53 lb	FT = 20%

LUMBER-

TOP CHORD 2x4 SP No.1
BOT CHORD 2x4 SP No.1
OTHERS 2x4 SP No.2

BRACING-

TOP CHORD Structural wood sheathing directly applied or 6-0-0 oc purlins.
BOT CHORD Rigid ceiling directly applied or 10-0-0 oc bracing.

REACTIONS.

All bearings 12-0-14.
(lb) - Max Horz 1=130(LC 8)
Max Uplift All uplift 100 lb or less at joint(s) 1, 5 except 8=150(LC 12), 6=150(LC 13)
Max Grav All reactions 250 lb or less at joint(s) 1, 5, 7 except 8=334(LC 19), 6=334(LC 20)

FORCES.

(lb) - Max. Comp./Max. Ten. - All forces 250 (lb) or less except when shown.

WEBS 2-8=-344/282, 4-6=-344/282

NOTES-

- Unbalanced roof live loads have been considered for this design.
- Wind: ASCE 7-10; Vult=130mph Vasd=103mph; TCDL=6.0psf; BCDL=6.0psf; h=15ft; Cat. II; Exp C; Enclosed; MWFRS (envelope) and C-C Exterior(2) 0-4-6 to 4-9-2, Interior(1) 4-9-2 to 6-0-7, Exterior(2) 6-0-7 to 10-5-4, Interior(1) 10-5-4 to 11-8-8 zone; C-C for members and forces & MWFRS for reactions shown; Lumber DOL=1.60 plate grip DOL=1.60
- Gable requires continuous bottom chord bearing.
- This truss has been designed for a 10.0 psf bottom chord live load nonconcurrent with any other live loads.
- * This truss has been designed for a live load of 30.0psf on the bottom chord in all areas where a rectangle 3-6-0 tall by 2-0-0 wide will fit between the bottom chord and any other members.
- Provide mechanical connection (by others) of truss to bearing plate capable of withstanding 100 lb uplift at joint(s) 1, 5 except (jt=lb) 8=150, 6=150.



November 9, 2021

WARNING - Verify design parameters and READ NOTES ON THIS AND INCLUDED MITEK REFERENCE PAGE MII-7473 rev. 5/19/2020 BEFORE USE.

Design valid for use only with MiTek® connectors. This design is based only upon parameters shown, and is for an individual building component, not a truss system. Before use, the building designer must verify the applicability of design parameters and properly incorporate this design into the overall building design. Bracing indicated is to prevent buckling of individual truss web and/or chord members only. Additional temporary and permanent bracing is always required for stability and to prevent collapse with possible personal injury and property damage. For general guidance regarding the fabrication, storage, delivery, erection and bracing of trusses and truss systems, see **ANSI/TPI1 Quality Criteria, DSB-89 and BCSI Building Component Safety Information** available from Truss Plate Institute, 2670 Crain Highway, Suite 203 Waldorf, MD 20601



818 Soundside Road
Edenton, NC 27932

Job J0322-1269	Truss V4	Truss Type VALLEY	Qty 1	Ply 1	Lot 5 Cypress Road Job Reference (optional)	E16391044
-------------------	-------------	----------------------	----------	----------	--	-----------

Comtech, Inc. Fayetteville, NC - 28314,

8.430 s Aug 16 2021 MiTek Industries, Inc. Mon Nov 8 13:12:48 2021 Page 1
ID:J6aSr?qB6etazEy6hKRSkZzPTZ_-nh1B?KcfXx_Tn7c6agHvFkFhXQpW3SsF17?wWyyLEND

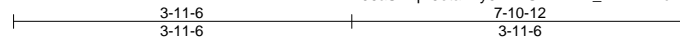

4x4 =

Scale = 1:25.3

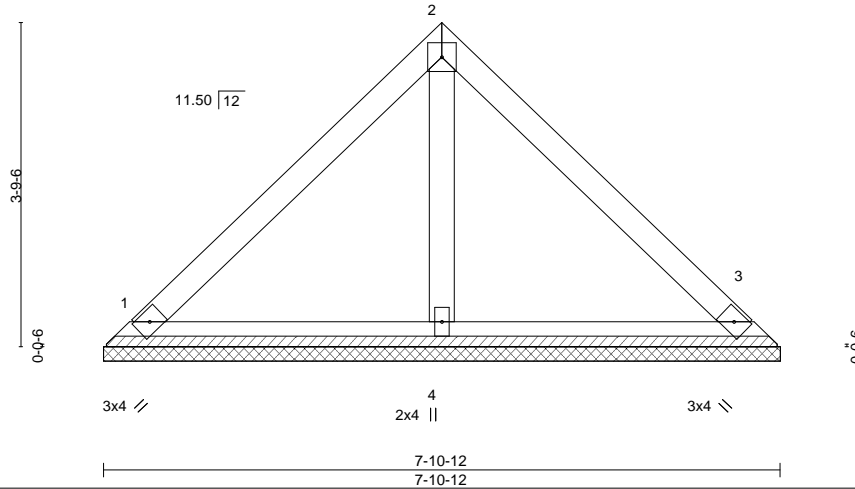

LOADING (psf)	SPACING-	2-0-0	CSI.	DEFL.	in (loc)	l/defl	L/d	PLATES	GRIP	
TCLL 20.0	Plate Grip DOL	1.15	TC 0.21	Vert(LL)	n/a	-	n/a	999	MT20	244/190
TCDL 10.0	Lumber DOL	1.15	BC 0.10	Vert(CT)	n/a	-	n/a	999		
BCLL 0.0 *	Rep Stress Incr	YES	WB 0.03	Horz(CT)	0.00	3	n/a	n/a		
BCDL 10.0	Code IRC2015/TPI2014		Matrix-P						Weight: 31 lb	FT = 20%

LUMBER-

TOP CHORD 2x4 SP No.1
BOT CHORD 2x4 SP No.1
OTHERS 2x4 SP No.2

BRACING-

TOP CHORD Structural wood sheathing directly applied or 6-0-0 oc purlins.
BOT CHORD Rigid ceiling directly applied or 10-0-0 oc bracing.

REACTIONS.

(size) 1=7-10-12, 3=7-10-12, 4=7-10-12
Max Horz 1=82(LC 8)
Max Uplift 1=30(LC 13), 3=31(LC 13)
Max Grav 1=173(LC 1), 3=173(LC 1), 4=228(LC 1)

FORCES. (lb) - Max. Comp./Max. Ten. - All forces 250 (lb) or less except when shown.

NOTES-

- 1) Unbalanced roof live loads have been considered for this design.
- 2) Wind: ASCE 7-10; Vult=130mph Vasd=103mph; TCCL=6.0psf; BCCL=6.0psf; h=15ft; Cat. II; Exp C; Enclosed; MWFRS (envelope) and C-C Exterior(2) zone;C-C for members and forces & MWFRS for reactions shown; Lumber DOL=1.60 plate grip DOL=1.60
- 3) Gable requires continuous bottom chord bearing.
- 4) This truss has been designed for a 10.0 psf bottom chord live load nonconcurrent with any other live loads.
- 5) * This truss has been designed for a live load of 30.0psf on the bottom chord in all areas where a rectangle 3-6-0 tall by 2-0-0 wide will fit between the bottom chord and any other members.
- 6) Provide mechanical connection (by others) of truss to bearing plate capable of withstanding 100 lb uplift at joint(s) 1, 3.



November 9, 2021

WARNING - Verify design parameters and READ NOTES ON THIS AND INCLUDED MITTEK REFERENCE PAGE MII-7473 rev. 5/19/2020 BEFORE USE.

Design valid for use only with MiTek® connectors. This design is based only upon parameters shown, and is for an individual building component, not a truss system. Before use, the building designer must verify the applicability of design parameters and properly incorporate this design into the overall building design. Bracing indicated is to prevent buckling of individual truss web and/or chord members only. Additional temporary and permanent bracing is always required for stability and to prevent collapse with possible personal injury and property damage. For general guidance regarding the fabrication, storage, delivery, erection and bracing of trusses and truss systems, see **ANSI/TPI1 Quality Criteria, DSB-89 and BCSI Building Component Safety Information** available from Truss Plate Institute, 2670 Crain Highway, Suite 203 Waldorf, MD 20601



818 Soundside Road
Edenton, NC 27932

Job J0322-1269	Truss V5	Truss Type VALLEY	Qty 1	Ply 1	Lot 5 Cypress Road Job Reference (optional)	E16391045
-------------------	-------------	----------------------	----------	----------	--	-----------

Comtech, Inc., Fayetteville, NC - 28314,

8.430 s Aug 16 2021 MiTek Industries, Inc. Mon Nov 8 13:12:48 2021 Page 1
ID:J6aSr?qB6etazEy6hKRSkZzPTZ_nh1B?KcfXx_Tn7c6agHvFkFIQqk3SEFI7?wWyyLEND

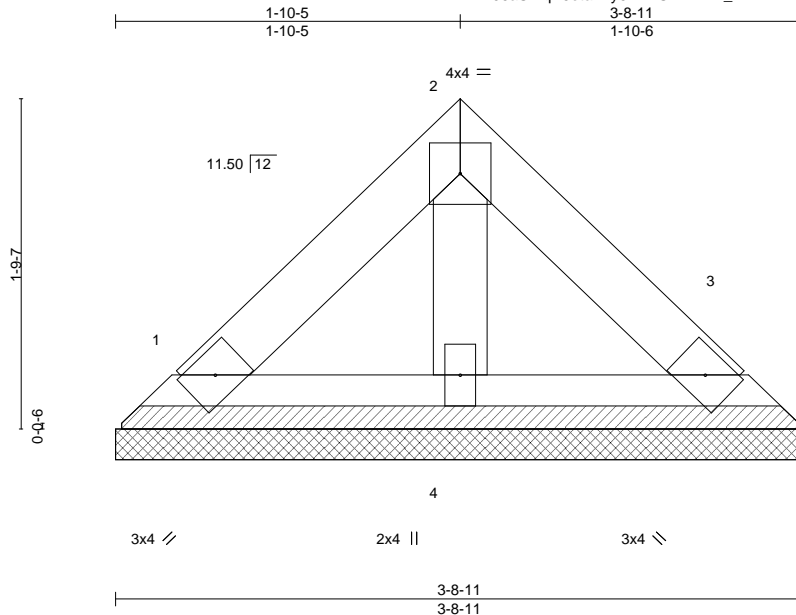

Scale = 1:11.7

LOADING (psf)	SPACING-	2-0-0	CSI.	DEFL.	in (loc)	l/defl	L/d	PLATES	GRIP
TCLL 20.0	Plate Grip DOL	1.15	TC 0.03	Vert(LL)	n/a	-	n/a	MT20	244/190
TCDL 10.0	Lumber DOL	1.15	BC 0.02	Vert(CT)	n/a	-	n/a		
BCLL 0.0 *	Rep Stress Incr	YES	WB 0.01	Horz(CT)	0.00	3	n/a		
BCDL 10.0	Code IRC2015/TPI2014		Matrix-P					Weight: 13 lb	FT = 20%

LUMBER-

TOP CHORD 2x4 SP No.1
BOT CHORD 2x4 SP No.1
OTHERS 2x4 SP No.2

BRACING-

TOP CHORD Structural wood sheathing directly applied or 3-8-11 oc purlins.
BOT CHORD Rigid ceiling directly applied or 10-0-0 oc bracing.

REACTIONS.

(size) 1=3-8-11, 3=3-8-11, 4=3-8-11
Max Horz 1=34(LC 9)
Max Uplift 1=12(LC 13), 3=13(LC 13)
Max Grav 1=72(LC 1), 3=72(LC 1), 4=95(LC 1)

FORCES. (lb) - Max. Comp./Max. Ten. - All forces 250 (lb) or less except when shown.

NOTES-

- Unbalanced roof live loads have been considered for this design.
- Wind: ASCE 7-10; Vult=130mph Vasd=103mph; TCDL=6.0psf; BCDL=6.0psf; h=15ft; Cat. II; Exp C; Enclosed; MWFRS (envelope) and C-C Exterior(2) zone; C-C for members and forces & MWFRS for reactions shown; Lumber DOL=1.60 plate grip DOL=1.60
- Gable requires continuous bottom chord bearing.
- This truss has been designed for a 10.0 psf bottom chord live load nonconcurrent with any other live loads.
- * This truss has been designed for a live load of 30.0psf on the bottom chord in all areas where a rectangle 3-6-0 tall by 2-0-0 wide will fit between the bottom chord and any other members.
- Provide mechanical connection (by others) of truss to bearing plate capable of withstanding 100 lb uplift at joint(s) 1, 3.



November 9, 2021

WARNING - Verify design parameters and READ NOTES ON THIS AND INCLUDED MITEK REFERENCE PAGE MII-7473 rev. 5/19/2020 BEFORE USE.

Design valid for use only with MiTek® connectors. This design is based only upon parameters shown, and is for an individual building component, not a truss system. Before use, the building designer must verify the applicability of design parameters and properly incorporate this design into the overall building design. Bracing indicated is to prevent buckling of individual truss web and/or chord members only. Additional temporary and permanent bracing is always required for stability and to prevent collapse with possible personal injury and property damage. For general guidance regarding the fabrication, storage, delivery, erection and bracing of trusses and truss systems, see **ANSI/TPI1 Quality Criteria, DSB-89 and BCSI Building Component Safety Information** available from Truss Plate Institute, 2670 Crain Highway, Suite 203 Waldorf, MD 20601



818 Soundside Road
Edenton, NC 27932

Symbols

PLATE LOCATION AND ORIENTATION

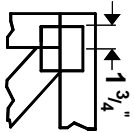

Center plate on joint unless x, y offsets are indicated. Dimensions are in ft-in-sixteenths. Apply plates to both sides of truss and fully embed teeth.

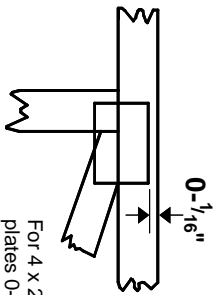

For 4 x 2 orientation, locate plates 0- $\frac{1}{16}$ " from outside edge of truss.

— This symbol indicates the required direction of slots in connector plates.

* Plate location details available in **MITek 20/20** software or upon request.

PLATE SIZE

4 X 4

The first dimension is the plate width measured perpendicular to slots. Second dimension is the length parallel to slots.

LATERAL BRACING LOCATION



Indicated by symbol shown and/or by text in the bracing section of the output. Use T or I bracing if indicated.

BEARING

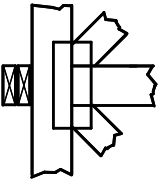

Indicates location where bearings (supports) occur. Icons vary but reaction section indicates joint number where bearings occur. Min size shown is for crushing only.

Industry Standards:

ANSI/TP1: National Design Specification for Metal Plate Connected Wood Truss Construction.
DSB-89: Design Standard for Bracing.
BCSI: Building Component Safety Information, Guide to Good Practice for Handling, Installing & Bracing of Metal Plate Connected Wood Trusses.

Numbering System

6-4-8 dimensions shown in ft-in-sixteenths (Drawings not to scale)

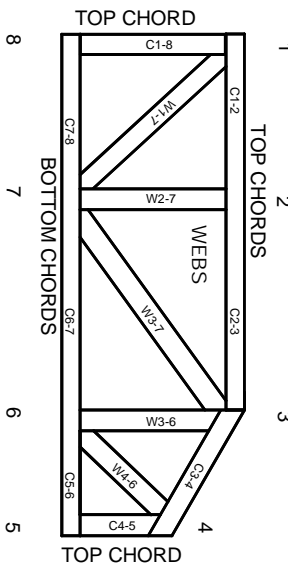

JOINTS ARE GENERALLY NUMBERED/LETTERED CLOCKWISE AROUND THE TRUSS STARTING AT THE JOINT FARTHEST TO THE LEFT.

CHORDS AND WEBS ARE IDENTIFIED BY END JOINT NUMBERS/LETTERS.

PRODUCT CODE APPROVALS

ICC-ES Reports:

ESR-1311, ESR-1352, ESR 1988
ER-3907, ESR-2362, ESR-1397, ESR-3282

Trusses are designed for wind loads in the plane of the truss unless otherwise shown.

Lumber design values are in accordance with ANSI/TP1 section 6.3 These truss designs rely on lumber values established by others.

© 2012 MITek® All Rights Reserved

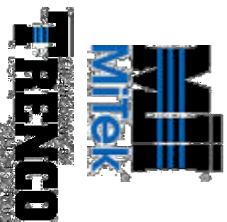

MITek Engineering Reference Sheet: Mill-7473 rev. 5/19/2020

General Safety Notes

Failure to Follow Could Cause Property Damage or Personal Injury

1. Additional stability bracing for truss system, e.g. diagonal or X-bracing, is always required. See BCSI.
2. Truss bracing must be designed by an engineer. For wide truss spacing, individual lateral braces themselves may require bracing, or alternative Tor I bracing should be considered.
3. Never exceed the design loading shown and never stack materials on inadequately braced trusses.
4. Provide copies of this truss design to the building designer, erection supervisor, property owner and all other interested parties.
5. Cut members to bear tightly against each other.
6. Place plates on each face of truss at each joint and embed fully. Knots and wane at joint locations are regulated by ANSI/TP1.
7. Design assumes trusses will be suitably protected from the environment in accord with ANSI/TP1.
8. Unless otherwise noted, moisture content of lumber shall not exceed 19% at time of fabrication.
9. Unless expressly noted, this design is not applicable for use with fire retardant, preservative treated, or green lumber.
10. Camber is a non-structural consideration and is the responsibility of truss fabricator. General practice is to camber for dead load deflection.
11. Plate type, size, orientation and location dimensions indicated are minimum plating requirements.
12. Lumber used shall be of the species and size, and in all respects, equal to or better than that specified.
13. Top chords must be sheathed or purlins provided at spacing indicated on design.
14. Bottom chords require lateral bracing at 10 ft. spacing, or less, if no ceiling is installed, unless otherwise noted.
15. Connections not shown are the responsibility of others.
16. Do not cut or alter truss member or plate without prior approval of an engineer.
17. Install and load vertically unless indicated otherwise.
18. Use of green or treated lumber may pose unacceptable environmental, health or performance risks. Consult with project engineer before use.
19. Review all portions of this design (front, back, words and pictures) before use. Reviewing pictures alone is not sufficient.
20. Design assumes manufacture in accordance with ANSI/TP1 Quality Criteria.
21. The design does not take into account any dynamic or other loads other than those expressly stated.



Client: Benjamin Stout Real Estate
 Project: The Ashville
 Address: Cypress Road
 Fayetteville, NC 28304

Date: 3/10/2022
 Input by: David Landry
 Job Name: Lot 5 Cypress Road
 Project #: J0322-1270

BM1 Kerto-S LVL 1.750" X 14.000" 2-Ply - PASSED

Level: Level

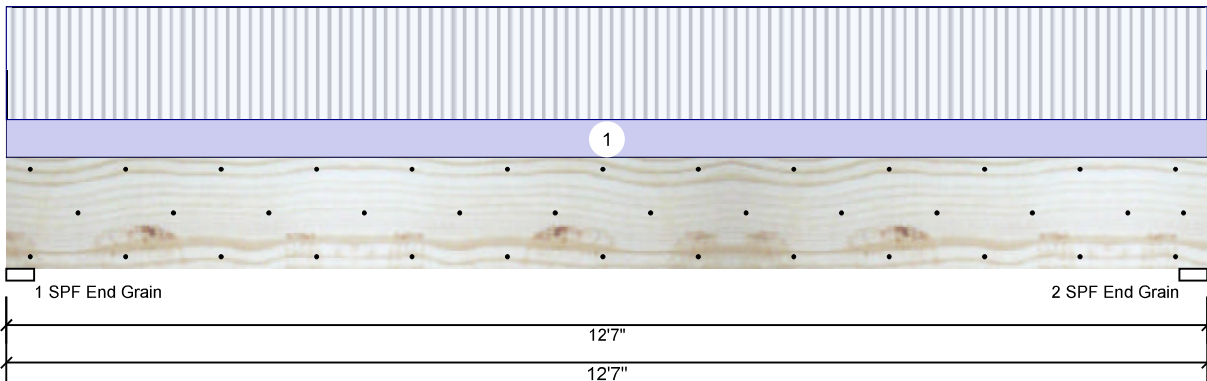

Member Information

Type:	Girder
Plies:	2
Moisture Condition:	Dry
Deflection LL:	480
Deflection TL:	360
Importance:	Normal
Temperature:	Temp <= 100°F

Application:	Floor
Design Method:	ASD
Building Code:	IBC/IRC 2015
Load Sharing:	No
Deck:	Not Checked

Reactions UNPATTERNED lb (Uplift)

Brg	Live	Dead	Snow	Wind	Const
1	4568	1591	0	0	0
2	4568	1591	0	0	0

Bearings

Bearing	Length	Cap. React	D/L lb	Total Ld.	Case	Ld. Comb.
1 - SPF End Grain	3.500"	58%	1591 / 4568	6159	L	D+L
2 - SPF End Grain	3.500"	58%	1591 / 4568	6159	L	D+L

Analysis Results

Analysis	Actual	Location	Allowed	Capacity	Comb.	Case
Moment	17989 ft-lb	6'3 1/2"	26999 ft-lb	0.666 (67%)	D+L	L
Unbraced	17989 ft-lb	6'3 1/2"	18055 ft-lb	0.996 (100%)	D+L	L
Shear	4792 lb	11'2 1/4"	10453 lb	0.458 (46%)	D+L	L
LL Defl inch	0.252 (L/578)	6'3 1/2"	0.303 (L/480)	0.830 (83%)	L	L
TL Defl inch	0.340 (L/428)	6'3 1/2"	0.404 (L/360)	0.840 (84%)	D+L	L

Design Notes

- 1 Fasten all plies using 3 rows of 10d Box nails (.128x3") at 12" o.c. Maximum end distance not to exceed 6".
- 2 Refer to last page of calculations for fasteners required for specified loads.
- 3 Girders are designed to be supported on the bottom edge only.
- 4 Top loads must be supported equally by all plies.
- 5 Top must be laterally braced at a maximum of 5'4 1/2" o.c.
- 6 Bottom braced at bearings.
- 7 Lateral slenderness ratio based on single ply width.

ID	Load Type	Location	Trib Width	Side	Dead 0.9	Live 1	Snow 1.15	Wind 1.6	Const. 1.25	Comments
1	Uniform			Top	242 PLF	726 PLF	0 PLF	0 PLF	0 PLF	F1
	Self Weight				11 PLF					

Notes
 Calculated Structural Designs is responsible only of the structural adequacy of this component based on the design criteria and loadings shown. It is the responsibility of the customer and/or the contractor to ensure the component suitability of the intended application, and to verify the dimensions and loads.
Lumber
 1. Dry service conditions, unless noted otherwise
 2. LVL not to be treated with fire retardant or corrosive chemicals

- Handling & Installation**
1. LVL beams must not be cut or drilled
 2. Refer to manufacturer's product information regarding installation requirements, multi-ply fastening details, beam strength values, and code approvals
 3. Damaged Beams must not be used
 4. Design assumes top edge is laterally restrained
 5. Provide lateral support at bearing points to avoid lateral displacement and rotation

6. For flat roofs provide proper drainage to prevent ponding
 This design is valid until 4/24/2023

Manufacturer Info
 Metsä Wood
 301 Merritt 7 Building, 2nd Floor
 Norwalk, CT 06851
 (800) 622-5850
 www.metsawood.com/us
 ICC-ES: ESR-3633

Comtech, Inc.
 1001 S. Reilly Road, Suite #639
 Fayetteville, NC
 USA
 28314
 910-864-TRUS



Client: Benjamin Stout Real Estate
 Project: The Ashville
 Address: Cypress Road
 Fayetteville, NC 28304

Date: 3/10/2022
 Input by: David Landry
 Job Name: Lot 5 Cypress Road
 Project #: J0322-1270

BM1 Kerto-S LVL 1.750" X 14.000" 2-Ply - PASSED

Level: Level

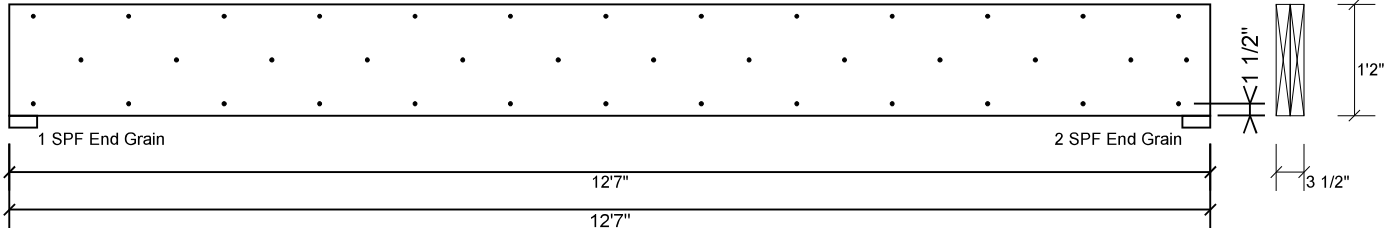

Multi-Ply Analysis

Fasten all plies using 3 rows of 10d Box nails (.128x3") at 12" o.c.. Maximum end distance not to exceed 6"

Capacity	0.0 %
Load	0.0 PLF
Yield Limit per Foot	245.6 PLF
Yield Limit per Fastener	81.9 lb.
Yield Mode	IV
Edge Distance	1 1/2"
Min. End Distance	3"
Load Combination	
Duration Factor	1.00

Notes

Calculated Structured Designs is responsible only of the structural adequacy of this component based on the design criteria and loadings shown. It is the responsibility of the customer and/or the contractor to ensure the component suitability of the intended application, and to verify the dimensions and loads.

Lumber

1. Dry service conditions, unless noted otherwise
2. LVL not to be treated with fire retardant or corrosive

Handling & Installation

1. LVL beams must not be cut or drilled
2. Refer to manufacturer's product information regarding installation requirements, multi-ply fastening details, beam strength values, and code approvals
3. Damaged Beams must not be used
4. Design assumes top edge is laterally restrained
5. Provide lateral support at bearing points to avoid lateral displacement and rotation

6. For flat roofs provide proper drainage to prevent ponding

This design is valid until 4/24/2023

Manufacturer Info

Metsä Wood
 301 Merritt 7 Building, 2nd Floor
 Norwalk, CT 06851
 (800) 622-5850
www.metsawood.com/us
 ICC-ES: ESR-3633

Comtech, Inc.
 1001 S. Reilly Road, Suite #639
 Fayetteville, NC
 USA
 28314
 910-864-TRUS





Client: Benjamin Stout Real Estate
 Project: The Ashville
 Address: Cypress Road
 Fayetteville, NC 28304

Date: 3/10/2022
 Input by: David Landry
 Job Name: Lot 5 Cypress Road
 Project #: J0322-1270

BM2 Kerto-S LVL 1.750" X 14.000" 2-Ply - PASSED

Level: Level

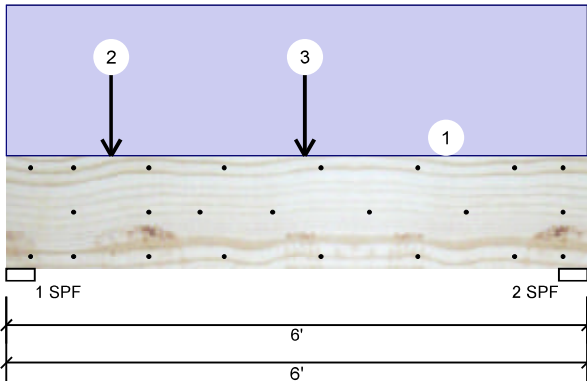

Member Information

Type:	Girder
Plies:	2
Moisture Condition:	Dry
Deflection LL:	480
Deflection TL:	360
Importance:	Normal
Temperature:	Temp <= 100°F

Application:	Floor
Design Method:	ASD
Building Code:	IBC/IRC 2015
Load Sharing:	No
Deck:	Not Checked

Reactions UNPATTERNED lb (Uplift)

Brg	Live	Dead	Snow	Wind	Const
1	678	709	0	0	0
2	189	546	0	0	0

Bearings

Bearing	Length	Cap. React	D/L lb	Total	Ld. Case	Ld. Comb.
1 - SPF	3.500"	27%	709 / 678	1387	L	D+L
2 - SPF	3.500"	14%	546 / 189	734	L	D+L

Analysis Results

Analysis	Actual	Location	Allowed	Capacity	Comb.	Case
Moment	1305 ft-lb	2'8 7/16"	26999 ft-lb	0.048 (5%)	D+L	L
Unbraced	1305 ft-lb	2'8 7/16"	17623 ft-lb	0.074 (7%)	D+L	L
Shear	1162 lb	1'4 3/4"	10453 lb	0.111 (11%)	D+L	L
LL Defl inch	0.003 (L/21799)	2'7 3/8"	0.139 (L/480)	0.020 (2%)	L	L
TL Defl inch	0.008 (L/8727)	2'10 1/16"	0.185 (L/360)	0.040 (4%)	D+L	L

Design Notes

- 1 Fasten all plies using 3 rows of 10d Box nails (.128x3") at 12" o.c. Maximum end distance not to exceed 6".
- 2 Refer to last page of calculations for fasteners required for specified loads.
- 3 Concentrated load fastener specification is in addition to hanger fasteners if a hanger is present.
- 4 Girders are designed to be supported on the bottom edge only.
- 5 Top loads must be supported equally by all plies.
- 6 Top braced at bearings.
- 7 Bottom braced at bearings.
- 8 Lateral slenderness ratio based on single ply width.

ID	Load Type	Location	Trib Width	Side	Dead 0.9	Live 1	Snow 1.15	Wind 1.6	Const. 1.25	Comments
1	Uniform			Top	150 PLF	0 PLF	0 PLF	0 PLF	0 PLF	Wall Above
2	Point	1-1-0		Far Face	238 lb	714 lb	0 lb	0 lb	0 lb	F2A
3	Point	3-1-0		Far Face	51 lb	153 lb	0 lb	0 lb	0 lb	F7
	Self Weight				11 PLF					

Notes
 Calculated Structured Designs is responsible only of the structural adequacy of this component based on the design criteria and loadings shown. It is the responsibility of the customer and/or the contractor to ensure the component suitability of the intended application, and to verify the dimensions and loads.

Lumber
 1. Dry service conditions, unless noted otherwise
 2. LVL not to be treated with fire retardant or corrosive chemicals

Handling & Installation
 1. LVL beams must not be cut or drilled
 2. Refer to manufacturer's product information regarding installation requirements, multi-ply fastening details, beam strength values, and code approvals
 3. Damaged Beams must not be used
 4. Design assumes top edge is laterally restrained
 5. Provide lateral support at bearing points to avoid lateral displacement and rotation

6. For flat roofs provide proper drainage to prevent ponding

This design is valid until 4/24/2023

Manufacturer Info
 Metsä Wood
 301 Merritt 7 Building, 2nd Floor
 Norwalk, CT 06851
 (800) 622-5850
 www.metsawood.com/us
 ICC-ES: ESR-3633

Comtech, Inc.
 1001 S. Reilly Road, Suite #639
 Fayetteville, NC
 USA
 28314
 910-864-TRUS



Client: Benjamin Stout Real Estate
 Project: The Ashville
 Address: Cypress Road
 Fayetteville, NC 28304

Date: 3/10/2022
 Input by: David Landry
 Job Name: Lot 5 Cypress Road
 Project #: J0322-1270

BM2 Kerto-S LVL 1.750" X 14.000" 2-Ply - PASSED

Level: Level

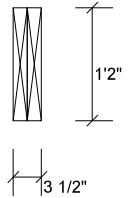
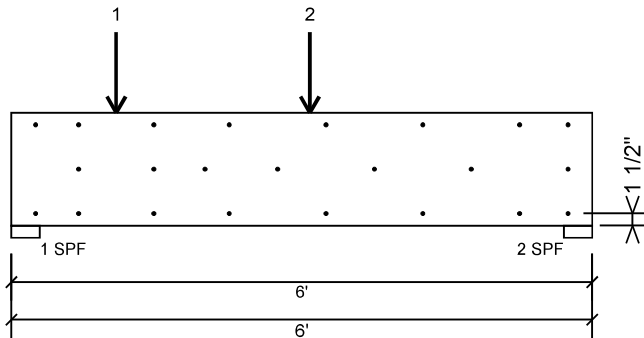

Multi-Ply Analysis

Fasten all plies using 3 rows of 10d Box nails (.128x3") at 12" o.c., except for regions covered by concentrated load fastening. Maximum end distance not to exceed 6"

Capacity	0.0 %
Load	0.0 PLF
Yield Limit per Foot	245.6 PLF
Yield Limit per Fastener	81.9 lb.
Yield Mode	IV
Edge Distance	1 1/2"
Min. End Distance	3"
Load Combination	
Duration Factor	1.00

Concentrated Load

Fasten at concentrated side load at 1-1-0 with a minimum of (6) – 10d Box nails (.128x3") in the pattern shown.

Capacity	96.9 %
Load	476.0lb.
Total Yield Limit	491.0 lb.
Cg	0.9998
Yield Limit per Fastener	81.9 lb.
Yield Mode	IV
Load Combination	D+L
Duration Factor	1.00

Min/Max fastener distances for Concentrated Side Loads

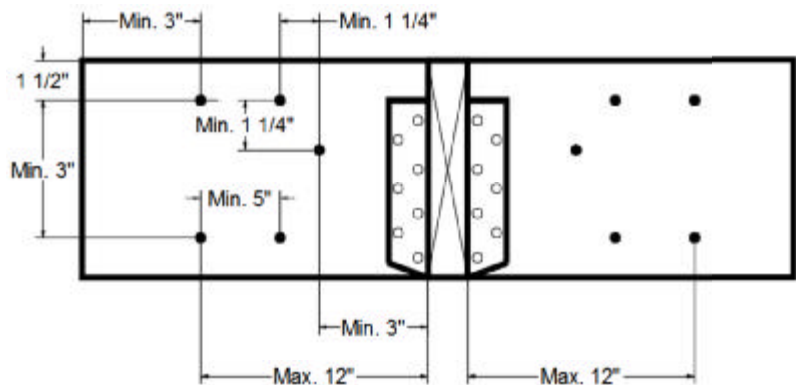

Notes

Calculated Structured Designs is responsible only of the structural adequacy of this component based on the design criteria and loadings shown. It is the responsibility of the customer and/or the contractor to ensure the component suitability of the intended application, and to verify the dimensions and loads.

Lumber

1. Dry service conditions, unless noted otherwise
2. LVL not to be treated with fire retardant or corrosive

chemicals

Handling & Installation

1. LVL beams must not be cut or drilled
2. Refer to manufacturer's product information regarding installation requirements, multi-ply fastening details, beam strength values, and code approvals
3. Damaged Beams must not be used
4. Design assumes top edge is laterally restrained
5. Provide lateral support at bearing points to avoid lateral displacement and rotation

6. For flat roofs provide proper drainage to prevent ponding

Manufacturer Info

Metsä Wood
 301 Merritt 7 Building, 2nd Floor
 Norwalk, CT 06851
 (800) 622-5850
www.metsawood.com/us
 ICC-ES: ESR-3633

Comtech, Inc.
 1001 S. Reilly Road, Suite #639
 Fayetteville, NC
 USA
 28314
 910-864-TRUS



This design is valid until 4/24/2023



Client: Benjamin Stout Real Estate
 Project: The Ashville
 Address: Cypress Road
 Fayetteville, NC 28304

Date: 3/10/2022
 Input by: David Landry
 Job Name: Lot 5 Cypress Road
 Project #: J0322-1270

BM3 S-P-F #2 2.000" X 12.000" 2-Ply - PASSED

Level: Level

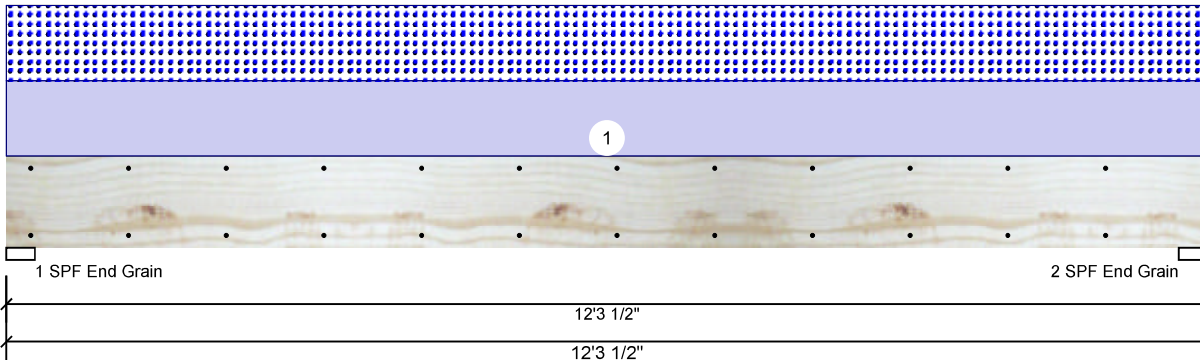

Member Information

Type:	Girder
Plies:	2
Moisture Condition:	Dry
Deflection LL:	480
Deflection TL:	360
Importance:	Normal
Temperature:	Temp <= 100°F

Application:	Floor
Design Method:	ASD
Building Code:	IBC/IRC 2015
Load Sharing:	No
Deck:	Not Checked

Reactions UNPATTERNED lb (Uplift)

Brg	Live	Dead	Snow	Wind	Const
1	0	799	799	0	0
2	0	799	799	0	0

Bearings

Bearing	Length	Cap. React	D/L lb	Total	Ld. Case	Ld. Comb.
1 - SPF End Grain	3.500"	36%	799 / 799	1598	L	D+S
2 - SPF End Grain	3.500"	36%	799 / 799	1598	L	D+S

Analysis Results

Analysis	Actual	Location	Allowed	Capacity	Comb.	Case
Moment	4551 ft-lb	6'1 3/4"	5306 ft-lb	0.858 (86%)	D+S	L
Unbraced	4551 ft-lb	6'1 3/4"	4558 ft-lb	0.998 (100%)	D+S	L
Shear	1295 lb	1'2"	3493 lb	0.371 (37%)	D+S	L
LL Defl inch	0.115 (L/1234)	6'1 3/4"	0.296 (L/480)	0.390 (39%)	S	L
TL Defl inch	0.230 (L/617)	6'1 3/4"	0.394 (L/360)	0.580 (58%)	D+S	L

Design Notes

- 1 Fasten all plies using 2 rows of 10d Box nails (.128x3") at 12" o.c. Maximum end distance not to exceed 6".
- 2 Refer to last page of calculations for fasteners required for specified loads.
- 3 Girders are designed to be supported on the bottom edge only.
- 4 Top loads must be supported equally by all plies.
- 5 Top must be laterally braced at a maximum of 6'1 1/2" o.c.
- 6 Bottom braced at bearings.
- 7 Lateral slenderness ratio based on single ply width.

ID	Load Type	Location	Trib Width	Side	Dead	Live	Snow	Wind	Const.	Comments
1	Uniform			Top	0.9	130 PLF	1.15	1.6	1.25	D1

Manufacturer Info

Comtech, Inc.
 1001 S. Reilly Road, Suite #639
 Fayetteville, NC
 USA
 28314
 910-864-TRUS



This design is valid until 4/24/2023



Client: Benjamin Stout Real Estate
 Project: The Ashville
 Address: Cypress Road
 Fayetteville, NC 28304

Date: 3/10/2022
 Input by: David Landry
 Job Name: Lot 5 Cypress Road
 Project #: J0322-1270

BM3 S-P-F #2 2.000" X 12.000" 2-Ply - PASSED

Level: Level

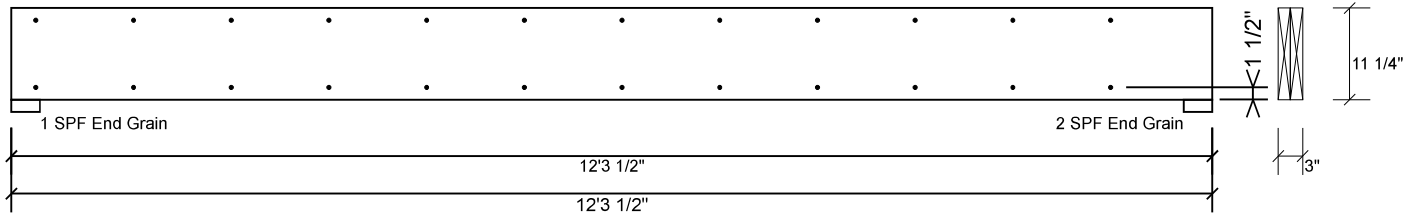

Multi-Ply Analysis

Fasten all plies using 2 rows of 10d Box nails (.128x3") at 12" o.c.. Maximum end distance not to exceed 6"

Capacity	0.0 %
Load	0.0 PLF
Yield Limit per Foot	157.4 PLF
Yield Limit per Fastener	78.7 lb.
Yield Mode	IV
Edge Distance	1 1/2"
Min. End Distance	3"
Load Combination	
Duration Factor	1.00

Manufacturer Info	Comtech, Inc. 1001 S. Reilly Road, Suite #639 Fayetteville, NC USA 28314 910-864-TRUS

This design is valid until 4/24/2023



Client: Benjamin Stout Real Estate
 Project: The Ashville
 Address: Cypress Road
 Fayetteville, NC 28304

Date: 3/10/2022
 Input by: David Landry
 Job Name: Lot 5 Cypress Road
 Project #: J0322-1270

BM4 Kerto-S LVL 1.750" X 9.250" 2-Ply - PASSED

Level: Level

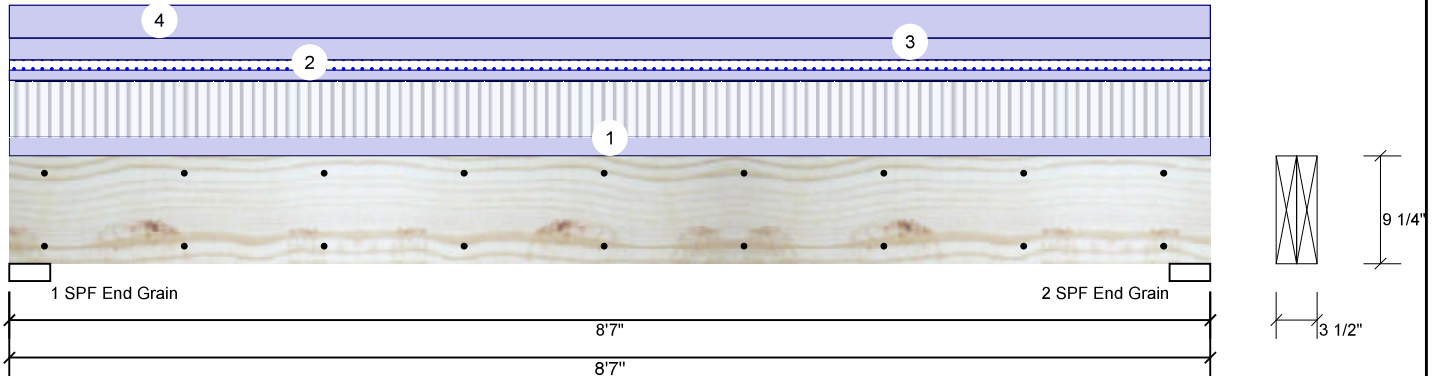

Member Information

Type:	Girder
Plies:	2
Moisture Condition:	Dry
Deflection LL:	480
Deflection TL:	360
Importance:	Normal
Temperature:	Temp <= 100°F

Application:	Floor
Design Method:	ASD
Building Code:	IBC/IRC 2015
Load Sharing:	No
Deck:	Not Checked

Reactions UNPATTERNED lb (Uplift)

Brg	Live	Dead	Snow	Wind	Const
1	1330	2005	240	0	0
2	1330	2005	240	0	0

Bearings

Bearing	Length	Cap. React	D/L lb	Total	Ld. Case	Ld. Comb.
1 - SPF End Grain	3.500"	31%	2005 / 1330	3335	L	D+L
2 - SPF End Grain	3.500"	31%	2005 / 1330	3335	L	D+L

Analysis Results

Analysis	Actual	Location	Allowed	Capacity	Comb.	Case
Moment	6413 ft-lb	4'3 1/2"	12542 ft-lb	0.511 (51%)	D+L	L
Unbraced	6413 ft-lb	4'3 1/2"	8468 ft-lb	0.757 (76%)	D+L	L
Shear	2558 lb	1'	6907 lb	0.370 (37%)	D+L	L
LL Defl inch	0.075 (L/1301)	4'3 9/16"	0.203 (L/480)	0.370 (37%)	L	L
TL Defl inch	0.188 (L/519)	4'3 9/16"	0.271 (L/360)	0.690 (69%)	D+L	L

Design Notes

- 1 Fasten all plies using 2 rows of 10d Box nails (.128x3") at 12" o.c. Maximum end distance not to exceed 6".
- 2 Refer to last page of calculations for fasteners required for specified loads.
- 3 Girders are designed to be supported on the bottom edge only.
- 4 Top loads must be supported equally by all plies.
- 5 Top braced at bearings.
- 6 Bottom braced at bearings.
- 7 Lateral slenderness ratio based on single ply width.

ID	Load Type	Location	Trib Width	Side	Dead 0.9	Live 1	Snow 1.15	Wind 1.6	Const. 1.25	Comments
1	Uniform			Top	104 PLF	310 PLF	0 PLF	0 PLF	0 PLF	F1
2	Uniform			Top	56 PLF	0 PLF	56 PLF	0 PLF	0 PLF	M1
3	Uniform			Top	120 PLF	0 PLF	0 PLF	0 PLF	0 PLF	Wall Above
4	Uniform			Top	180 PLF	0 PLF	0 PLF	0 PLF	0 PLF	C1GE
	Self Weight				7 PLF					

Notes
 Calculated Structured Designs is responsible only of the structural adequacy of this component based on the design criteria and loadings shown. It is the responsibility of the customer and/or the contractor to ensure the component suitability of the intended application, and to verify the dimensions and loads.
Lumber
 1. Dry service conditions, unless noted otherwise
 2. LVL not to be treated with fire retardant or corrosive chemicals

Handling & Installation
 1. LVL beams must not be cut or drilled
 2. Refer to manufacturer's product information regarding installation requirements, multi-ply fastening details, beam strength values, and code approvals
 3. Damaged Beams must not be used
 4. Design assumes top edge is laterally restrained
 5. Provide lateral support at bearing points to avoid lateral displacement and rotation

6. For flat roofs provide proper drainage to prevent ponding
 This design is valid until 4/24/2023

Manufacturer Info
 Metsä Wood
 301 Merritt 7 Building, 2nd Floor
 Norwalk, CT 06851
 (800) 622-5850
 www.metsawood.com/us
 ICC-ES: ESR-3633

Comtech, Inc.
 1001 S. Reilly Road, Suite #639
 Fayetteville, NC
 USA
 28314
 910-864-TRUS



Client: Benjamin Stout Real Estate
 Project: The Ashville
 Address: Cypress Road
 Fayetteville, NC 28304

Date: 3/10/2022
 Input by: David Landry
 Job Name: Lot 5 Cypress Road
 Project #: J0322-1270

BM4 Kerto-S LVL 1.750" X 9.250" 2-Ply - PASSED

Level: Level

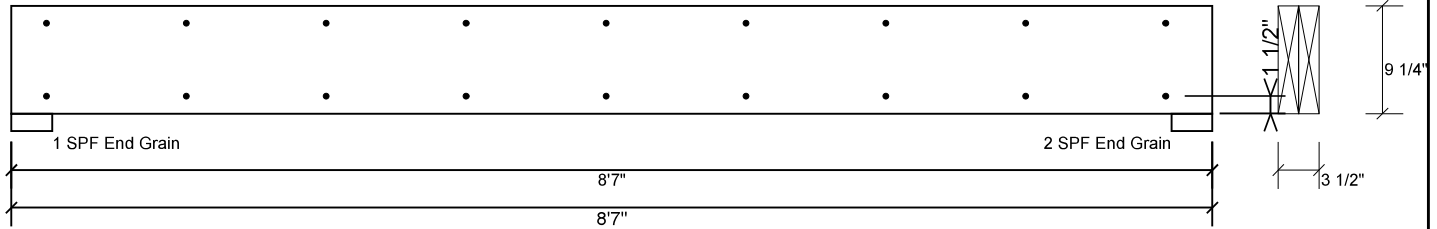

Multi-Ply Analysis

Fasten all plies using 2 rows of 10d Box nails (.128x3") at 12" o.c.. Maximum end distance not to exceed 6"

Capacity	0.0 %
Load	0.0 PLF
Yield Limit per Foot	163.7 PLF
Yield Limit per Fastener	81.9 lb.
Yield Mode	IV
Edge Distance	1 1/2"
Min. End Distance	3"
Load Combination	
Duration Factor	1.00

Notes

Calculated Structured Designs is responsible only of the structural adequacy of this component based on the design criteria and loadings shown. It is the responsibility of the customer and/or the contractor to ensure the component suitability of the intended application, and to verify the dimensions and loads.

Lumber

1. Dry service conditions, unless noted otherwise
2. LVL not to be treated with fire retardant or corrosive chemicals

Handling & Installation

1. LVL beams must not be cut or drilled
2. Refer to manufacturer's product information regarding installation requirements, multi-ply fastening details, beam strength values, and code approvals
3. Damaged Beams must not be used
4. Design assumes top edge is laterally restrained
5. Provide lateral support at bearing points to avoid lateral displacement and rotation

6. For flat roofs provide proper drainage to prevent ponding

This design is valid until 4/24/2023

Manufacturer Info

Metsä Wood
 301 Merritt 7 Building, 2nd Floor
 Norwalk, CT 06851
 (800) 622-5850
www.metsawood.com/us
 ICC-ES: ESR-3633

Comtech, Inc.
 1001 S. Reilly Road, Suite #639
 Fayetteville, NC
 USA
 28314
 910-864-TRUS





Client: Benjamin Stout Real Estate
 Project: The Ashville
 Address: Cypress Road
 Fayetteville, NC 28304

Date: 3/10/2022
 Input by: David Landry
 Job Name: Lot 5 Cypress Road
 Project #: J0322-1270

BM5 Kerto-S LVL 1.750" X 11.875" 2-Ply - PASSED Level: Level

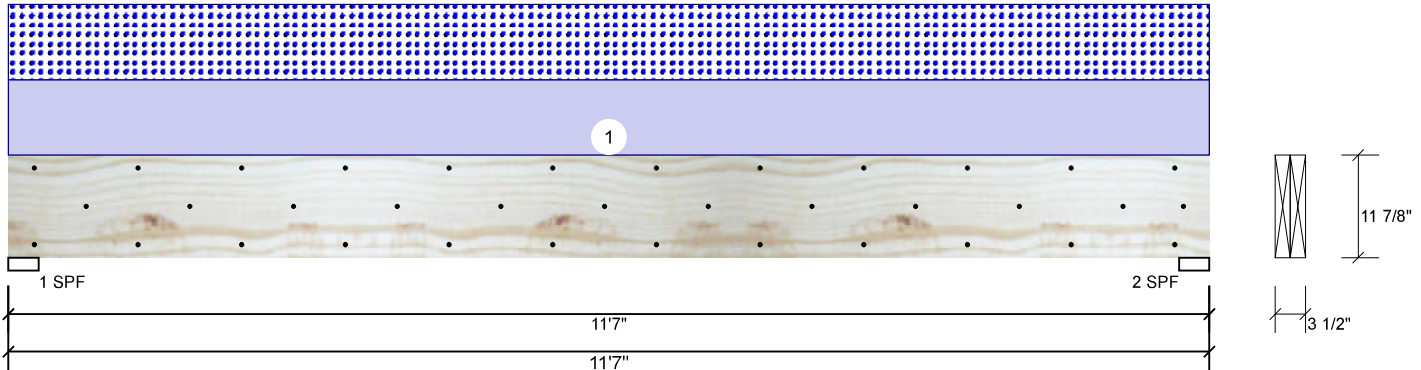

Member Information

Type:	Girder
Plies:	2
Moisture Condition:	Dry
Deflection LL:	480
Deflection TL:	360
Importance:	Normal
Temperature:	Temp <= 100°F

Application:	Floor
Design Method:	ASD
Building Code:	IBC/IRC 2015
Load Sharing:	No
Deck:	Not Checked

Reactions UNPATTERNED lb (Uplift)

Brg	Live	Dead	Snow	Wind	Const
1	0	1559	1506	0	0
2	0	1559	1506	0	0

Bearings

Bearing	Length	Cap. React	D/L lb	Total	Ld. Case	Ld. Comb.
1 - SPF	3.500"	59%	1559 / 1506	3065	L	D+S
2 - SPF	3.500"	59%	1559 / 1506	3065	L	D+S

Analysis Results

Analysis	Actual	Location	Allowed	Capacity	Comb.	Case
Moment	8188 ft-lb	5'9 1/2"	22897 ft-lb	0.358 (36%)	D+S	L
Unbraced	8188 ft-lb	5'9 1/2"	8589 ft-lb	0.953 (95%)	D+S	L
Shear	2935 lb	1'2 5/8"	10197 lb	0.288 (29%)	D+S	L
LL Defl inch	0.103 (L/1298)	5'9 1/2"	0.278 (L/480)	0.370 (37%)	S	L
TL Defl inch	0.209 (L/637)	5'9 1/2"	0.371 (L/360)	0.560 (56%)	D+S	L

Design Notes

- 1 Fasten all plies using 3 rows of 10d Box nails (.128x3") at 12" o.c. Maximum end distance not to exceed 6".
- 2 Refer to last page of calculations for fasteners required for specified loads.
- 3 Girders are designed to be supported on the bottom edge only.
- 4 Top braced at bearings.
- 5 Bottom braced at bearings.
- 6 Lateral slenderness ratio based on single ply width.

ID	Load Type	Location	Trib Width	Side	Dead 0.9	Live 1	Snow 1.15	Wind 1.6	Const. 1.25	Comments
1	Uniform			Far Face	260 PLF	0 PLF	260 PLF	0 PLF	0 PLF	A2
	Self Weight				9 PLF					

Notes
 Calculated Structured Designs is responsible only of the structural adequacy of this component based on the design criteria and loadings shown. It is the responsibility of the customer and/or the contractor to ensure the component suitability of the intended application, and to verify the dimensions and loads.

Lumber
 1. Dry service conditions, unless noted otherwise
 2. LVL not to be treated with fire retardant or corrosive chemicals

- Handling & Installation**
1. LVL beams must not be cut or drilled
 2. Refer to manufacturer's product information regarding installation requirements, multi-ply fastening details, beam strength values, and code approvals
 3. Damaged Beams must not be used
 4. Design assumes top edge is laterally restrained
 5. Provide lateral support at bearing points to avoid lateral displacement and rotation

6. For flat roofs provide proper drainage to prevent ponding

This design is valid until 4/24/2023

Manufacturer Info
 Metsä Wood
 301 Merritt 7 Building, 2nd Floor
 Norwalk, CT 06851
 (800) 622-5850
www.metsawood.com/us
 ICC-ES: ESR-3633

Comtech, Inc.
 1001 S. Reilly Road, Suite #639
 Fayetteville, NC
 USA
 28314
 910-864-TRUS



Client: Benjamin Stout Real Estate
 Project: The Ashville
 Address: Cypress Road
 Fayetteville, NC 28304

Date: 3/10/2022
 Input by: David Landry
 Job Name: Lot 5 Cypress Road
 Project #: J0322-1270

BM5 Kerto-S LVL 1.750" X 11.875" 2-Ply - PASSED Level: Level

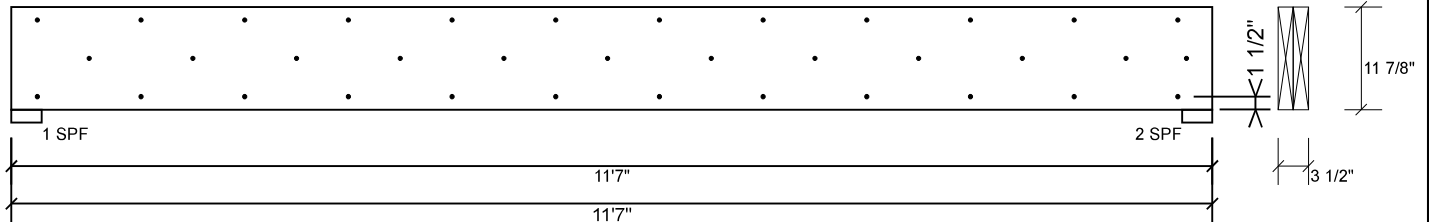

Multi-Ply Analysis

Fasten all plies using 3 rows of 10d Box nails (.128x3") at 12" o.c.. Maximum end distance not to exceed 6"

Capacity	92.1 %
Load	260.0 PLF
Yield Limit per Foot	282.4 PLF
Yield Limit per Fastener	94.1 lb.
Yield Mode	IV
Edge Distance	1 1/2"
Min. End Distance	3"
Load Combination	D+S
Duration Factor	1.15

Notes

Calculated Structured Designs is responsible only of the structural adequacy of this component based on the design criteria and loadings shown. It is the responsibility of the customer and/or the contractor to ensure the component suitability of the intended application, and to verify the dimensions and loads.

Lumber

1. Dry service conditions, unless noted otherwise
2. LVL not to be treated with fire retardant or corrosive chemicals

Handling & Installation

1. LVL beams must not be cut or drilled
2. Refer to manufacturer's product information regarding installation requirements, multi-ply fastening details, beam strength values, and code approvals
3. Damaged Beams must not be used
4. Design assumes top edge is laterally restrained
5. Provide lateral support at bearing points to avoid lateral displacement and rotation

6. For flat roofs provide proper drainage to prevent ponding

This design is valid until 4/24/2023

Manufacturer Info

Metsä Wood
 301 Merritt 7 Building, 2nd Floor
 Norwalk, CT 06851
 (800) 622-5850
www.metsawood.com/us
 ICC-ES: ESR-3633

Comtech, Inc.
 1001 S. Reilly Road, Suite #639
 Fayetteville, NC
 USA
 28314
 910-864-TRUS





Client: Benjamin Stout Real Estate
 Project: The Ashville
 Address: Cypress Road
 Fayetteville, NC 28304

Date: 3/10/2022
 Input by: David Landry
 Job Name: Lot 5 Cypress Road
 Project #: J0322-1270

GDH Kerto-S LVL 1.750" X 11.875" 2-Ply - PASSED

Level: Level

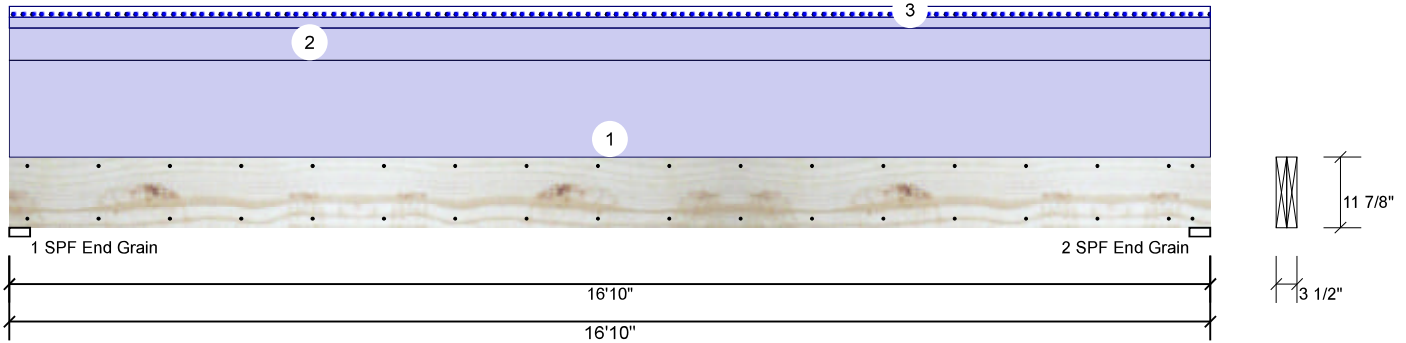

Member Information

Type:	Girder
Plies:	2
Moisture Condition:	Dry
Deflection LL:	480
Deflection TL:	360
Importance:	Normal
Temperature:	Temp <= 100°F

Application:	Floor
Design Method:	ASD
Building Code:	IBC/IRC 2015
Load Sharing:	No
Deck:	Not Checked

Reactions UNPATTERNED lb (Uplift)

Brg	Live	Dead	Snow	Wind	Const
1	0	2266	168	0	0
2	0	2266	168	0	0

Bearings

Bearing	Length	Cap. React	D/L lb	Total	Ld. Case	Ld. Comb.
1 - SPF End Grain	3.500"	23%	2266 / 168	2434	L	D+S
2 - SPF End Grain	3.500"	23%	2266 / 168	2434	L	D+S

Analysis Results

Analysis	Actual	Location	Allowed	Capacity	Comb.	Case
Moment	9024 ft-lb	8'5"	17919 ft-lb	0.504 (50%)	D	Uniform
Unbraced	9694 ft-lb	8'5"	9704 ft-lb	0.999 (100%)	D+S	L
Shear	1938 lb	15'7 3/8"	7980 lb	0.243 (24%)	D	Uniform
LL Defl inch	0.035 (L/5617)	8'5 1/16"	0.409 (L/480)	0.090 (9%)	S	L
TL Defl inch	0.506 (L/388)	8'5 1/16"	0.546 (L/360)	0.930 (93%)	D+S	L

Design Notes

- 1 Fasten all plies using 2 rows of 10d Box nails (.128x3") at 12" o.c. Maximum end distance not to exceed 6".
- 2 Refer to last page of calculations for fasteners required for specified loads.
- 3 Girders are designed to be supported on the bottom edge only.
- 4 Top loads must be supported equally by all plies.
- 5 Top must be laterally braced at a maximum of 9'6 3/4" o.c.
- 6 Bottom braced at bearings.
- 7 Lateral slenderness ratio based on single ply width.

ID	Load Type	Location	Trib Width	Side	Dead 0.9	Live 1	Snow 1.15	Wind 1.6	Const. 1.25	Comments
1	Uniform			Top	180 PLF	0 PLF	0 PLF	0 PLF	0 PLF	B1GE
2	Uniform			Top	60 PLF	0 PLF	0 PLF	0 PLF	0 PLF	Wall Above
3	Tie-In Self Weight	0-0-0 to 16-10-0	1-0-0	Top	20 PSF 9 PLF	0 PSF	20 PSF	0 PSF	0 PSF	Roof Load

Notes
 Calculated Structured Designs is responsible only of the structural adequacy of this component based on the design criteria and loadings shown. It is the responsibility of the customer and/or the contractor to ensure the component suitability of the intended application, and to verify the dimensions and loads.
Lumber
 1. Dry service conditions, unless noted otherwise
 2. LVL not to be treated with fire retardant or corrosive chemicals

- Handling & Installation**
1. LVL beams must not be cut or drilled
 2. Refer to manufacturer's product information regarding installation requirements, multi-ply fastening details, beam strength values, and code approvals
 3. Damaged Beams must not be used
 4. Design assumes top edge is laterally restrained
 5. Provide lateral support at bearing points to avoid lateral displacement and rotation

6. For flat roofs provide proper drainage to prevent ponding
 This design is valid until 4/24/2023

Manufacturer Info
 Metsä Wood
 301 Merritt 7 Building, 2nd Floor
 Norwalk, CT 06851
 (800) 622-5850
 www.metsawood.com/us
 ICC-ES: ESR-3633

Comtech, Inc.
 1001 S. Reilly Road, Suite #639
 Fayetteville, NC
 USA
 28314
 910-864-TRUS



Client: Benjamin Stout Real Estate
 Project: The Ashville
 Address: Cypress Road
 Fayetteville, NC 28304

Date: 3/10/2022
 Input by: David Landry
 Job Name: Lot 5 Cypress Road
 Project #: J0322-1270

GDH Kerto-S LVL 1.750" X 11.875" 2-Ply - PASSED

Level: Level

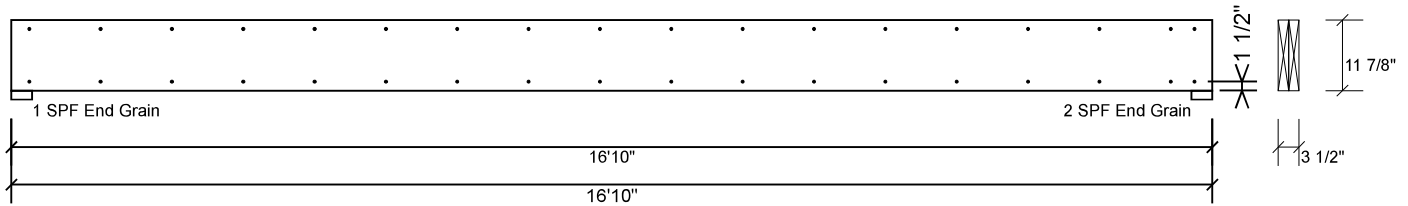

Multi-Ply Analysis

Fasten all plies using 2 rows of 10d Box nails (.128x3") at 12" o.c.. Maximum end distance not to exceed 6"

Capacity	0.0 %
Load	0.0 PLF
Yield Limit per Foot	163.7 PLF
Yield Limit per Fastener	81.9 lb.
Yield Mode	IV
Edge Distance	1 1/2"
Min. End Distance	3"
Load Combination	
Duration Factor	1.00

Notes

Calculated Structured Designs is responsible only of the structural adequacy of this component based on the design criteria and loadings shown. It is the responsibility of the customer and/or the contractor to ensure the component suitability of the intended application, and to verify the dimensions and loads.

Lumber

1. Dry service conditions, unless noted otherwise
2. LVL not to be treated with fire retardant or corrosive chemicals

Handling & Installation

1. LVL beams must not be cut or drilled
2. Refer to manufacturer's product information regarding installation requirements, multi-ply fastening details, beam strength values, and code approvals
3. Damaged Beams must not be used
4. Design assumes top edge is laterally restrained
5. Provide lateral support at bearing points to avoid lateral displacement and rotation

6. For flat roofs provide proper drainage to prevent ponding

This design is valid until 4/24/2023

Manufacturer Info

Metsä Wood
 301 Merritt 7 Building, 2nd Floor
 Norwalk, CT 06851
 (800) 622-5850
www.metsawood.com/us
 ICC-ES: ESR-3633

Comtech, Inc.
 1001 S. Reilly Road, Suite #639
 Fayetteville, NC
 USA
 28314
 910-864-TRUS





RE: J0322-1270
Lot 5 Cypress Road

Trenco
818 Soundside Rd
Edenton, NC 27932

Site Information:

Customer: Benjamin Stout Real Estate Project Name: J0322-1270
Lot/Block: 5 Model: Williams
Address: Cypress Road Subdivision: Cypress Road
City: Fayetteville State: NC

General Truss Engineering Criteria & Design Loads (Individual Truss Design Drawings Show Special Loading Conditions):

Design Code: IRC2015/TPI2014 Design Program: MiTek 20/20 8.4
Wind Code: N/A Wind Speed: N/A mph
Roof Load: N/A psf Floor Load: 55.0 psf

This package includes 13 individual, dated Truss Design Drawings and 0 Additional Drawings.

No.	Seal#	Truss Name	Date
1	E16391095	ET1	11/9/2021
2	E16391096	ET2	11/9/2021
3	E16391097	F1	11/9/2021
4	E16391098	F2	11/9/2021
5	E16391099	F2A	11/9/2021
6	E16391100	F3	11/9/2021
7	E16391101	F4	11/9/2021
8	E16391102	F4A	11/9/2021
9	E16391103	F5	11/9/2021
10	E16391104	F6	11/9/2021
11	E16391105	F7	11/9/2021
12	E16391106	FG1	11/9/2021
13	E16391107	FG2	11/9/2021

The truss drawing(s) referenced above have been prepared by Truss Engineering Co. under my direct supervision based on the parameters provided by Comtech, Inc - Fayetteville.

Truss Design Engineer's Name: Gilbert, Eric

My license renewal date for the state of North Carolina is December 31, 2022.

North Carolina COA: C-0844

IMPORTANT NOTE: The seal on these truss component designs is a certification that the engineer named is licensed in the jurisdiction(s) identified and that the designs comply with ANSI/TPI 1. These designs are based upon parameters shown (e.g., loads, supports, dimensions, shapes and design codes), which were given to TRENCO. Any project specific information included is for TRENCO customers file reference purpose only, and was not taken into account in the preparation of these designs. TRENCO has not independently verified the applicability of the design parameters or the designs for any particular building. Before use, the building designer should verify applicability of design parameters and properly incorporate these designs into the overall building design per ANSI/TPI 1, Chapter 2.



November 09, 2021

Job J0322-1270	Truss ET1	Truss Type GABLE	Qty 1	Ply 1	Lot 5 Cypress Road Job Reference (optional)	E16391095
-------------------	--------------	---------------------	----------	----------	--	-----------

Comtech, Inc, Fayetteville, NC - 28314,

8.430 s Aug 16 2021 MiTek Industries, Inc. Mon Nov 8 13:13:25 2021 Page 1
ID:J6aSr?qB6etazEy6hKRskZzPTZ_-ComAmz3tpJfDjpxDFyRbFXH3ZKSZEB?hFOTOJjyLEMe

0-1/8

0-1/8

Scale = 1:50.0

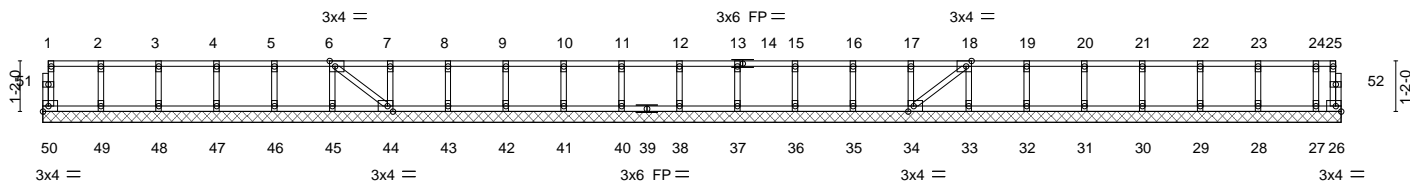

1-4-0	2-8-0	4-0-0	5-4-0	6-8-0	8-0-0	9-4-0	10-8-0	12-0-0	13-4-0	14-8-0	16-0-0	17-4-0	18-8-0	20-0-0	21-4-0	22-8-0	24-0-0	25-4-0	26-8-0	28-0-0	29-4-0	29-11-0
1-4-0	1-4-0	1-4-0	1-4-0	1-4-0	1-4-0	1-4-0	1-4-0	1-4-0	1-4-0	1-4-0	1-4-0	1-4-0	1-4-0	1-4-0	1-4-0	1-4-0	1-4-0	1-4-0	1-4-0	1-4-0	1-4-0	0-7-0

Plate Offsets (X,Y)-- [6:0-1-8,Edge], [18:0-1-8,Edge], [34:0-1-8,Edge], [44:0-1-8,Edge]

LOADING (psf)	SPACING-	2-0-0	CSI.	DEFL.	in	(loc)	l/defl	L/d	PLATES	GRIP
TCLL 40.0	Plate Grip DOL	1.00	TC 0.06	Vert(LL)	n/a	-	n/a	999	MT20	244/190
TCDL 10.0	Lumber DOL	1.00	BC 0.01	Vert(CT)	n/a	-	n/a	999		
BCLL 0.0	Rep Stress Incr	YES	WB 0.03	Horz(CT)	-0.00	26	n/a	n/a		
BCDL 5.0	Code IRC2015/TPI2014		Matrix-S						Weight: 128 lb	FT = 20%F, 11%E

LUMBER-

TOP CHORD 2x4 SP No.1(flat)
BOT CHORD 2x4 SP No.1(flat)
WEBS 2x4 SP No.3(flat)
OTHERS 2x4 SP No.3(flat)

BRACING-

TOP CHORD Structural wood sheathing directly applied or 6-0-0 oc purlins, except end verticals.
BOT CHORD Rigid ceiling directly applied or 6-0-0 oc bracing. Except: 10-0-0 oc bracing: 49-50,48-49,47-48,46-47,45-46,44-45.

REACTIONS.

All bearings 29-11-0.
(lb) - Max Uplift All uplift 100 lb or less at joint(s) 26
Max Grav All reactions 250 lb or less at joint(s) 50, 49, 48, 47, 46, 45, 44, 43, 42, 41, 40, 38, 37, 36, 35, 34, 33, 32, 31, 30, 29, 28, 27

FORCES. (lb) - Max. Comp./Max. Ten. - All forces 250 (lb) or less except when shown.

NOTES-

- All plates are 1.5x3 MT20 unless otherwise indicated.
- Plates checked for a plus or minus 1 degree rotation about its center.
- Gable requires continuous bottom chord bearing.
- Truss to be fully sheathed from one face or securely braced against lateral movement (i.e. diagonal web).
- Gable studs spaced at 1-4-0 oc.
- Provide mechanical connection (by others) of truss to bearing plate capable of withstanding 100 lb uplift at joint(s) 26.
- Recommend 2x6 strongbacks, on edge, spaced at 10-0-0 oc and fastened to each truss with 3-10d (0.131" X 3") nails. Strongbacks to be attached to walls at their outer ends or restrained by other means.



November 9,2021

WARNING - Verify design parameters and READ NOTES ON THIS AND INCLUDED MITEK REFERENCE PAGE MII-7473 rev. 5/19/2020 BEFORE USE.
Design valid for use only with MiTek® connectors. This design is based only upon parameters shown, and is for an individual building component, not a truss system. Before use, the building designer must verify the applicability of design parameters and properly incorporate this design into the overall building design. Bracing indicated is to prevent buckling of individual truss web and/or chord members only. Additional temporary and permanent bracing is always required for stability and to prevent collapse with possible personal injury and property damage. For general guidance regarding the fabrication, storage, delivery, erection and bracing of trusses and truss systems, see **ANSI/TPI1 Quality Criteria, DSB-89 and BCSI Building Component Safety Information** available from Truss Plate Institute, 2670 Crain Highway, Suite 203 Waldorf, MD 20601



818 Soundside Road
Edenton, NC 27932

Job J0322-1270	Truss ET2	Truss Type GABLE	Qty 1	Ply 1	Lot 5 Cypress Road Job Reference (optional)	E16391096
-------------------	--------------	---------------------	----------	----------	--	-----------

Comtech, Inc, Fayetteville, NC - 28314,

8.430 s Aug 16 2021 MiTek Industries, Inc. Mon Nov 8 13:13:26 2021 Page 1
ID:J6aSr?qB6etazEy6hKRskZzPTZ_-g?KYzJ3Vacn4KyWPpfyqnlpEHkoozeErU2CxrlyLEMd

0-1-8

Scale = 1:41.7

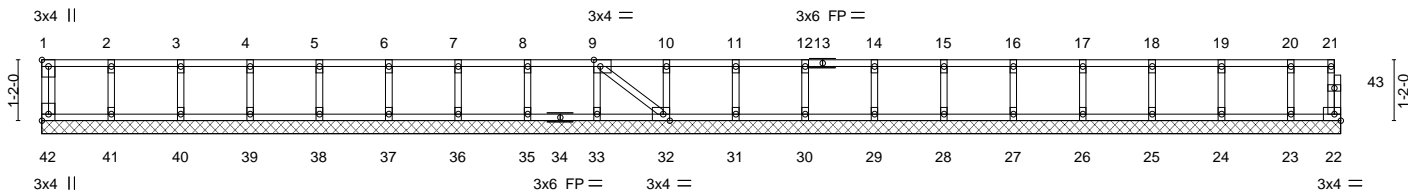

1-4-0	2-8-0	4-0-0	5-4-0	6-8-0	8-0-0	9-4-0	10-8-0	12-0-0	13-4-0	14-8-0	16-0-0	17-4-0	18-8-0	20-0-0	21-4-0	22-8-0	24-0-0	24-11-8
1-4-0	1-4-0	1-4-0	1-4-0	1-4-0	1-4-0	1-4-0	1-4-0	1-4-0	1-4-0	1-4-0	1-4-0	1-4-0	1-4-0	1-4-0	1-4-0	1-4-0	1-4-0	0-11-8

Plate Offsets (X,Y)-- [1:Edge,0-1-8], [9:0-1-8,Edge], [32:0-1-8,Edge], [42:Edge,0-1-8]

LOADING (psf)	SPACING-	2-0-0	CSI.	DEFL.	in	(loc)	l/defl	L/d	PLATES	GRIP
TCLL 40.0	Plate Grip DOL	1.00	TC 0.06	Vert(LL)	n/a	-	n/a	999	MT20	244/190
TCDL 10.0	Lumber DOL	1.00	BC 0.01	Vert(CT)	n/a	-	n/a	999		
BCLL 0.0	Rep Stress Incr	YES	WB 0.03	Horz(CT)	0.00	22	n/a	n/a		
BCDL 5.0	Code IRC2015/TPI2014		Matrix-S						Weight: 106 lb	FT = 20%F, 11%E

LUMBER-

TOP CHORD 2x4 SP No.1(flat)
BOT CHORD 2x4 SP No.1(flat)
WEBS 2x4 SP No.3(flat)
OTHERS 2x4 SP No.3(flat)

BRACING-

TOP CHORD Structural wood sheathing directly applied or 6-0-0 oc purlins, except end verticals.
BOT CHORD Rigid ceiling directly applied or 10-0-0 oc bracing.

REACTIONS.

All bearings 24-11-8.

(lb) - Max Grav All reactions 250 lb or less at joint(s) 42, 22, 41, 40, 39, 38, 37, 36, 35, 33, 32, 31, 30, 29, 28, 27, 26, 25, 24, 23

FORCES.

(lb) - Max. Comp./Max. Ten. - All forces 250 (lb) or less except when shown.

NOTES-

- All plates are 1.5x3 MT20 unless otherwise indicated.
- Plates checked for a plus or minus 1 degree rotation about its center.
- Gable requires continuous bottom chord bearing.
- Truss to be fully sheathed from one face or securely braced against lateral movement (i.e. diagonal web).
- Gable studs spaced at 1-4-0 oc.
- Recommend 2x6 strongbacks, on edge, spaced at 10-0-0 oc and fastened to each truss with 3-10d (0.131" X 3") nails. Strongbacks to be attached to walls at their outer ends or restrained by other means.
- CAUTION, Do not erect truss backwards.



November 9, 2021

WARNING - Verify design parameters and READ NOTES ON THIS AND INCLUDED MITEK REFERENCE PAGE MII-7473 rev. 5/19/2020 BEFORE USE.

Design valid for use only with MiTek® connectors. This design is based only upon parameters shown, and is for an individual building component, not a truss system. Before use, the building designer must verify the applicability of design parameters and properly incorporate this design into the overall building design. Bracing indicated is to prevent buckling of individual truss web and/or chord members only. Additional temporary and permanent bracing is always required for stability and to prevent collapse with possible personal injury and property damage. For general guidance regarding the fabrication, storage, delivery, erection and bracing of trusses and truss systems, see **ANSI/TPI1 Quality Criteria, DSB-89 and BCSI Building Component Safety Information** available from Truss Plate Institute, 2670 Crain Highway, Suite 203 Waldorf, MD 20601



818 Soundside Road
Edenton, NC 27932

Job J0322-1270	Truss F1	Truss Type Floor	Qty 8	Ply 1	Lot 5 Cypress Road Job Reference (optional)	E16391097
-------------------	-------------	---------------------	----------	----------	--	-----------

Comtech, Inc., Fayetteville, NC - 28314,

8.430 s Aug 16 2021 MiTek Industries, Inc. Mon Nov 8 13:13:28 2021 Page 1
ID:J6aSr?qB6etazEy6hKRSkZzPTZ_-cNRIO?5I6E1naGfow4_ItAvMLYG4RO68xMh2weyLEmb

0-1-8



0-1-8
Scale = 1:50.8

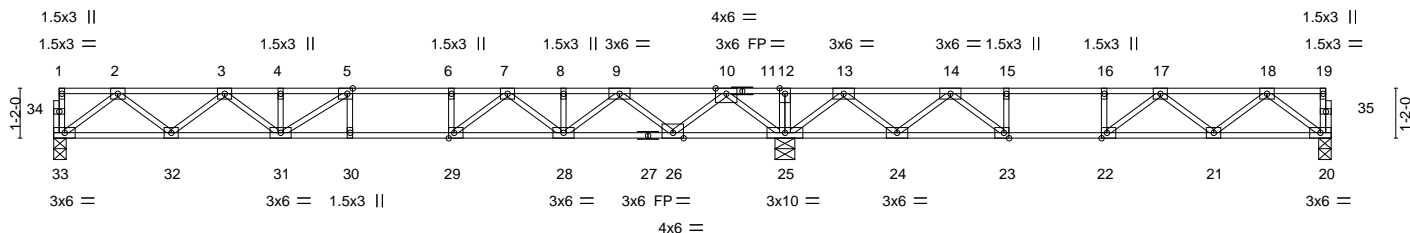

	17-1-8	29-11-0
	17-1-8	12-9-8
Plate Offsets (X,Y)--	[5:0-1-8,Edge], [22:0-1-8,Edge], [23:0-1-8,Edge], [29:0-1-8,Edge]	

LOADING (psf)	SPACING- 2-0-0	CSI.	DEFL. in (loc) l/defl L/d	PLATES	GRIP
TCLL 40.0	Plate Grip DOL 1.00	TC 0.86	Vert(LL) -0.20 30 >999 480	MT20	244/190
TCDL 10.0	Lumber DOL 1.00	BC 0.85	Vert(CT) -0.28 30 >735 360		
BCLL 0.0	Rep Stress Incr YES	WB 0.58	Horz(CT) 0.05 20 n/a n/a		
BCDL 5.0	Code IRC2015/TPI2014	Matrix-S			
				Weight: 149 lb	FT = 20%F, 11%E

LUMBER-	BRACING-
TOP CHORD 2x4 SP No.1 (flat)	TOP CHORD Structural wood sheathing directly applied or 6-0-0 oc purlins, except end verticals.
BOT CHORD 2x4 SP No.1 (flat)	BOT CHORD Rigid ceiling directly applied or 6-0-0 oc bracing.
WEBS 2x4 SP No.3 (flat)	

REACTIONS. (size) 33=0-3-8, 25=0-5-8, 20=0-3-8
Max Grav 33=826(LC 3), 25=1934(LC 1), 20=608(LC 4)

FORCES. (lb) - Max. Comp./Max. Ten. - All forces 250 (lb) or less except when shown.

TOP CHORD 2-3=-1695/0, 3-4=-2732/0, 4-5=-2732/0, 5-6=-2963/0, 6-7=-2963/0, 7-8=-2067/0, 8-9=-2067/0, 9-10=-539/303, 10-12=0/2152, 12-13=0/2152, 13-14=-551/972, 14-15=-1575/269, 15-16=-1575/269, 16-17=-1575/269, 17-18=-1162/0

BOT CHORD 32-33=0/1030, 31-32=0/2330, 30-31=0/2963, 29-30=0/2963, 28-29=0/2561, 26-28=-37/1417, 25-26=-833/0, 24-25=-1263/0, 23-24=-662/1135, 22-23=-269/1575, 21-22=-24/1515, 20-21=0/747

WEBS 2-33=-1290/0, 2-32=0/866, 3-32=-826/0, 3-31=0/514, 10-25=-1655/0, 10-26=0/1228, 9-26=-1188/0, 9-28=0/878, 7-28=-685/0, 7-29=0/807, 6-29=-359/0, 5-31=-475/153, 13-25=-1321/0, 13-24=0/882, 14-24=-926/0, 14-23=0/942, 18-20=-935/0, 18-21=0/540, 17-21=-460/99, 17-22=-345/76, 15-23=-417/0

- NOTES-**
- 1) Unbalanced floor live loads have been considered for this design.
 - 2) All plates are 3x4 MT20 unless otherwise indicated.
 - 3) Plates checked for a plus or minus 1 degree rotation about its center.
 - 4) Recommend 2x6 strongbacks, on edge, spaced at 10-0-0 oc and fastened to each truss with 3-10d (0.131" X 3") nails. Strongbacks to be attached to walls at their outer ends or restrained by other means.
 - 5) CAUTION, Do not erect truss backwards.



November 9, 2021

WARNING - Verify design parameters and READ NOTES ON THIS AND INCLUDED MITEK REFERENCE PAGE MII-7473 rev. 5/19/2020 BEFORE USE.
Design valid for use only with MiTek® connectors. This design is based only upon parameters shown, and is for an individual building component, not a truss system. Before use, the building designer must verify the applicability of design parameters and properly incorporate this design into the overall building design. Bracing indicated is to prevent buckling of individual truss web and/or chord members only. Additional temporary and permanent bracing is always required for stability and to prevent collapse with possible personal injury and property damage. For general guidance regarding the fabrication, storage, delivery, erection and bracing of trusses and truss systems, see **ANSI/TPI1 Quality Criteria, DSB-89 and BCSI Building Component Safety Information** available from Truss Plate Institute, 2670 Crain Highway, Suite 203 Waldorf, MD 20601



Job J0322-1270	Truss F2	Truss Type Floor	Qty 1	Ply 1	Lot 5 Cypress Road Job Reference (optional)	E16391098
-------------------	-------------	---------------------	----------	----------	--	-----------

Comtech, Inc, Fayetteville, NC - 28314,

8.430 s Aug 16 2021 MiTek Industries, Inc. Mon Nov 8 13:13:29 2021 Page 1
ID:J6aSr?qB6etazEy6hKRskZzPTZ_-4a?hcl6NtX9eBQE_UnWXPnRXuxcHAsbHA?RbS4yLEma

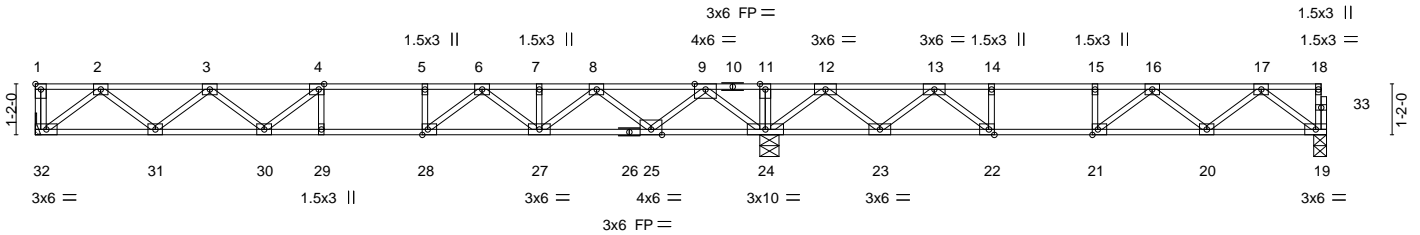

Plate Offsets (X,Y)--	[1:Edge,0-1-8], [4:0-1-8,Edge], [21:0-1-8,Edge], [22:0-1-8,Edge], [28:0-1-8,Edge]
-----------------------	---

LOADING (psf)	SPACING-	CSI.	DEFL.	in (loc)	l/defl	L/d	PLATES	GRIP
TCLL 40.0	2-0-0 Plate Grip DOL 1.00	TC 0.87	Vert(LL)	-0.18 28-29	>999	480	MT20	244/190
TCDL 10.0	Lumber DOL 1.00	BC 0.85	Vert(CT)	-0.25 28-29	>810	360		
BCLL 0.0	Rep Stress Incr YES	WB 0.57	Horz(CT)	0.05 19	n/a	n/a		
BCDL 5.0	Code IRC2015/TPI2014	Matrix-S					Weight: 146 lb	FT = 20%F, 11%E

LUMBER-	BRACING-
TOP CHORD 2x4 SP No.1(flat)	TOP CHORD Structural wood sheathing directly applied or 6-0-0 oc purlins, except end verticals.
BOT CHORD 2x4 SP No.1(flat)	BOT CHORD Rigid ceiling directly applied or 6-0-0 oc bracing.
WEBS 2x4 SP No.3(flat)	

REACTIONS. (size) 32=Mechanical, 19=0-3-8, 24=0-5-4
Max Grav 32=814(LC 3), 19=615(LC 4), 24=1907(LC 1)

FORCES. (lb) - Max. Comp./Max. Ten. - All forces 250 (lb) or less except when shown.
TOP CHORD 2-3=-1658/0, 3-4=-2582/0, 4-5=-2848/0, 5-6=-2848/0, 6-7=-2034/0, 7-8=-2034/0, 8-9=-563/296, 9-11=0/2082, 11-12=0/2082, 12-13=-578/905, 13-14=-1611/221, 14-15=-1611/221, 15-16=-1611/221, 16-17=-1179/0
BOT CHORD 31-32=0/1002, 30-31=0/2282, 29-30=0/2848, 28-29=0/2848, 27-28=0/2500, 25-27=-36/1414, 24-25=-810/0, 23-24=-1188/0, 22-23=-602/1165, 21-22=-221/1611, 20-21=0/1540, 19-20=0/756
WEBS 2-32=1257/0, 2-31=0/854, 3-31=-813/0, 3-30=0/392, 4-30=-431/27, 9-24=-1619/0, 9-25=0/1194, 8-25=-1155/0, 8-27=0/843, 6-27=-652/0, 6-28=0/750, 5-28=-323/0, 17-19=-946/0, 17-20=0/550, 16-20=-470/84, 16-21=-317/90, 12-24=-1316/0, 12-23=0/876, 13-23=-920/0, 13-22=0/936, 14-22=-417/0

- NOTES-**
- 1) Unbalanced floor live loads have been considered for this design.
 - 2) All plates are 3x4 MT20 unless otherwise indicated.
 - 3) Plates checked for a plus or minus 1 degree rotation about its center.
 - 4) Refer to girder(s) for truss to truss connections.
 - 5) Recommend 2x6 strongbacks, on edge, spaced at 10-0-0 oc and fastened to each truss with 3-10d (0.131" X 3") nails. Strongbacks to be attached to walls at their outer ends or restrained by other means.
 - 6) CAUTION, Do not erect truss backwards.



November 9, 2021

WARNING - Verify design parameters and READ NOTES ON THIS AND INCLUDED MITEK REFERENCE PAGE MII-7473 rev. 5/19/2020 BEFORE USE.
 Design valid for use only with MiTek® connectors. This design is based only upon parameters shown, and is for an individual building component, not a truss system. Before use, the building designer must verify the applicability of design parameters and properly incorporate this design into the overall building design. Bracing indicated is to prevent buckling of individual truss web and/or chord members only. Additional temporary and permanent bracing is always required for stability and to prevent collapse with possible personal injury and property damage. For general guidance regarding the fabrication, storage, delivery, erection and bracing of trusses and truss systems, see **ANSI/TPI1 Quality Criteria, DSB-89 and BCSI Building Component Safety Information** available from Truss Plate Institute, 2670 Crain Highway, Suite 203 Waldorf, MD 20601



818 Soundside Road
Edenton, NC 27932

Job	Truss	Truss Type	Qty	Ply	Lot 5 Cypress Road	E16391099
J0322-1270	F2A	Floor	1	1	Job Reference (optional)	

Comtech, Inc, Fayetteville, NC - 28314,

8.430 s Aug 16 2021 MiTek Industries, Inc. Mon Nov 8 13:13:31 2021 Page 1

ID:J6aSr?qB6etazEy6hKRskZzPTZ_-0y7R017eP9PMRkONcCY?UoWwalOYekCadJwiXzylEMY

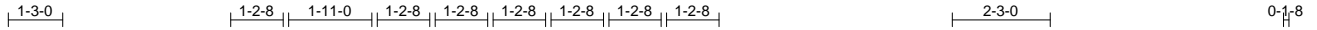

Scale = 1:50.0

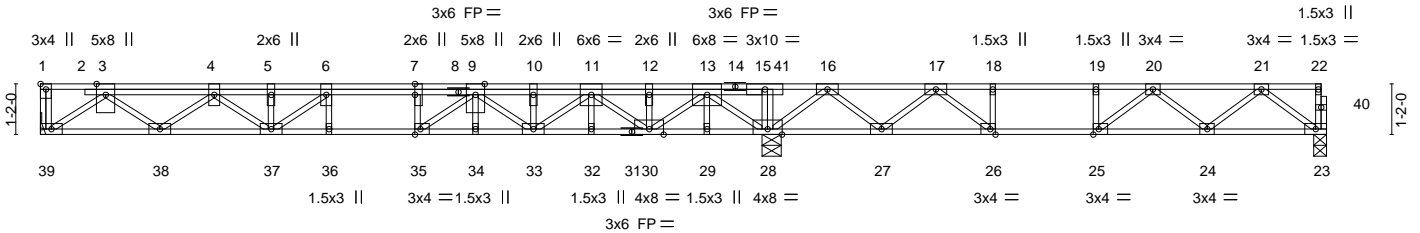

Plate Offsets (X,Y)--	[1:Edge,0-1-8], [7:0-3-0,Edge], [25:0-1-8,Edge], [26:0-1-8,Edge], [35:0-1-8,Edge]
-----------------------	---

LOADING (psf)	SPACING-	CSI.	DEFL.	in (loc)	l/defl	L/d	PLATES	GRIP
TCLL 40.0	Plate Grip DOL 1.00	TC 0.66	Vert(LL) -0.15	35	>999	480	MT20	244/190
TCDL 10.0	Lumber DOL 1.00	BC 0.48	Vert(CT) -0.20	35-36	>993	360		
BCLL 0.0	Rep Stress Incr NO	WB 0.69	Horz(CT) 0.04	23	n/a	n/a		
BCDL 5.0	Code IRC2015/TPI2014	Matrix-S						
							Weight: 173 lb	FT = 20%F, 11%E

LUMBER-

TOP CHORD 2x4 SP 2400F 2.0E(flat)
 BOT CHORD 2x4 SP 2400F 2.0E(flat)
 WEBS 2x4 SP No.3(flat)

BRACING-

TOP CHORD Structural wood sheathing directly applied or 6-0-0 oc purlins, except end verticals.
 BOT CHORD Rigid ceiling directly applied or 6-0-0 oc bracing.

REACTIONS.

(size) 39=Mechanical, 28=0-5-4, 23=0-3-8
 Max Grav 39=951(LC 3), 28=2436(LC 1), 23=579(LC 4)

FORCES.

(lb) - Max. Comp./Max. Ten. - All forces 250 (lb) or less except when shown.
 TOP CHORD 3-4=-2099/0, 4-5=-3320/0, 5-6=-3320/0, 6-7=-3521/0, 7-9=-3521/0, 9-10=-2750/0, 10-11=-2750/0, 11-12=-1201/0, 12-13=-1201/0, 13-15=0/2484, 15-16=0/2500, 16-17=-224/1085, 17-18=-1394/330, 18-19=-1394/330, 19-20=-1394/330, 20-21=-1095/0
 BOT CHORD 38-39=0/1255, 37-38=0/2907, 36-37=0/3521, 35-36=0/3521, 34-35=0/3180, 33-34=0/3180, 32-33=0/2041, 30-32=0/2041, 29-30=-501/77, 28-29=-501/77, 27-28=-1403/0, 26-27=-753/865, 25-26=-330/1394, 24-25=-59/1406, 23-24=0/710
 WEBS 3-39=-1541/0, 3-38=0/1072, 4-38=-1027/0, 4-37=0/515, 5-37=-259/12, 13-28=-2425/0, 13-30=0/1449, 11-30=-1115/0, 11-33=0/936, 9-33=-593/0, 9-35=0/799, 7-35=-397/0, 16-28=-1479/0, 6-37=-372/209, 16-27=0/905, 17-27=-970/0, 17-26=0/989, 18-26=-436/0, 21-23=-888/0, 21-24=-6/501, 20-24=-405/117, 20-25=-370/0

NOTES-

- 1) Unbalanced floor live loads have been considered for this design.
- 2) All plates are 3x6 MT20 unless otherwise indicated.
- 3) Plates checked for a plus or minus 1 degree rotation about its center.
- 4) Refer to girder(s) for truss to truss connections.
- 5) Recommend 2x6 strongbacks, on edge, spaced at 10-0-0 oc and fastened to each truss with 3-10d (0.131" X 3") nails. Strongbacks to be attached to walls at their outer ends or restrained by other means.
- 6) CAUTION, Do not erect truss backwards.
- 7) Hanger(s) or other connection device(s) shall be provided sufficient to support concentrated load(s) 222 lb down at 4-1-4, and 576 lb down at 15-1-12 on top chord. The design/selection of such connection device(s) is the responsibility of others.
- 8) In the LOAD CASE(S) section, loads applied to the face of the truss are noted as front (F) or back (B).

LOAD CASE(S) Standard

- 1) Dead + Floor Live (balanced): Lumber Increase=1.00, Plate Increase=1.00
 Uniform Loads (plf)
 Vert: 23-39=-10, 1-22=-100
 Concentrated Loads (lb)
 Vert: 4=-142(F) 13=-496(F)



November 9, 2021

WARNING - Verify design parameters and READ NOTES ON THIS AND INCLUDED MITEK REFERENCE PAGE MII-7473 rev. 5/19/2020 BEFORE USE.
 Design valid for use only with MiTek® connectors. This design is based only upon parameters shown, and is for an individual building component, not a truss system. Before use, the building designer must verify the applicability of design parameters and properly incorporate this design into the overall building design. Bracing indicated is to prevent buckling of individual truss web and/or chord members only. Additional temporary and permanent bracing is always required for stability and to prevent collapse with possible personal injury and property damage. For general guidance regarding the fabrication, storage, delivery, erection and bracing of trusses and truss systems, see **ANSI/TPI1 Quality Criteria, DSB-89 and BCSI Building Component Safety Information** available from Truss Plate Institute, 2670 Crain Highway, Suite 203 Waldorf, MD 20601



818 Soundside Road
 Edenton, NC 27932

Job J0322-1270	Truss F3	Truss Type Floor	Qty 1	Ply 1	Lot 5 Cypress Road Job Reference (optional)	E16391100
-------------------	-------------	---------------------	----------	----------	--	-----------

Comtech, Inc, Fayetteville, NC - 28314,

8.430 s Aug 16 2021 MiTek Industries, Inc. Mon Nov 8 13:32 2021 Page 1
ID:J6aSr?qB6etazEy6hKRSkZzPTZ_-U8hpEN8G9SXDXD2tz9w3E1036M9egNGIjszfF3PyLEMx

1-3-0

2-4-0

0-1-8

Scale: 1/2"=1'

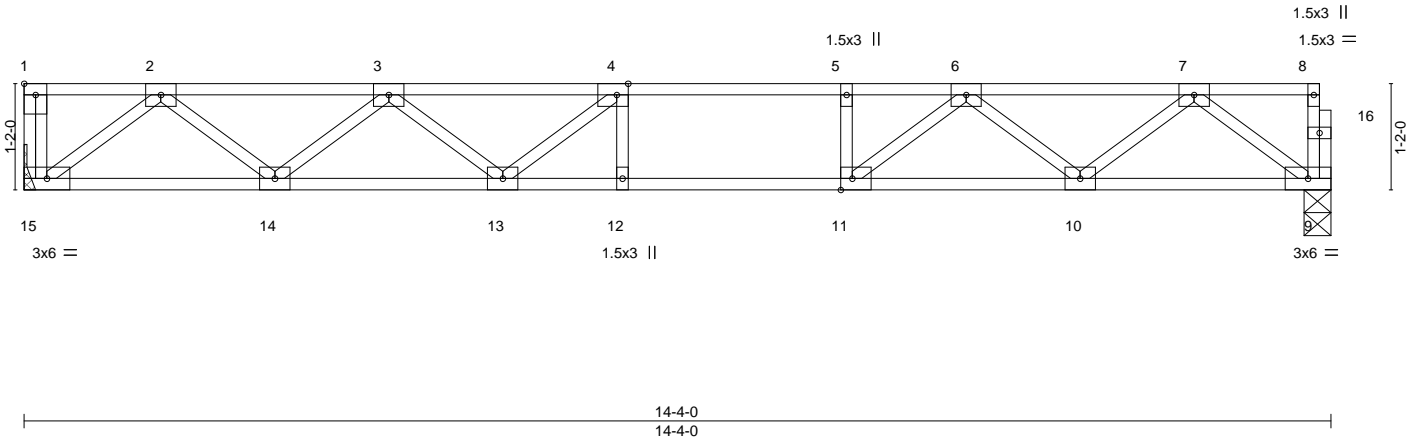

Plate Offsets (X,Y)-- [1:Edge,0-1-8], [4:0-1-8,Edge], [11:0-1-8,Edge]

LOADING (psf)	SPACING-	CSI.	DEFL.	PLATES	GRIP
TCLL 40.0	2-0-0	TC 0.60	in (loc) l/defl L/d	MT20	244/190
TCDL 10.0	Plate Grip DOL 1.00	BC 0.87	Vert(LL) -0.19 12-13 >906 480		
BCLL 0.0	Lumber DOL 1.00	WB 0.38	Vert(CT) -0.25 12-13 >687 360		
BCDL 5.0	Rep Stress Incr YES	Matrix-S	Horz(CT) 0.04 9 n/a n/a		
	Code IRC2015/TPI2014			Weight: 71 lb	FT = 20%F, 11%E

LUMBER-

TOP CHORD 2x4 SP No.1 (flat)
BOT CHORD 2x4 SP No.1 (flat)
WEBS 2x4 SP No.3 (flat)

BRACING-

TOP CHORD Structural wood sheathing directly applied or 6-0-0 oc purlins, except end verticals.
BOT CHORD Rigid ceiling directly applied or 10-0-0 oc bracing.

REACTIONS.

(size) 15=Mechanical, 9=0-3-8
Max Grav 15=775(LC 1), 9=768(LC 1)

FORCES.

(lb) - Max. Comp./Max. Ten. - All forces 250 (lb) or less except when shown.
TOP CHORD 2-3=-1559/0, 3-4=-2384/0, 4-5=-2550/0, 5-6=-2550/0, 6-7=-1538/0
BOT CHORD 14-15=0/947, 13-14=0/2143, 12-13=0/2550, 11-12=0/2550, 10-11=0/2118, 9-10=0/954
WEBS 2-15=-1188/0, 2-14=0/797, 3-14=-761/0, 3-13=0/398, 7-9=-1194/0, 7-10=0/760, 6-10=-755/0, 6-11=0/740, 5-11=-317/0, 4-13=-437/18

NOTES-

- Unbalanced floor live loads have been considered for this design.
- All plates are 3x4 MT20 unless otherwise indicated.
- Plates checked for a plus or minus 1 degree rotation about its center.
- Refer to girder(s) for truss to truss connections.
- Recommend 2x6 strongbacks, on edge, spaced at 10-0-0 oc and fastened to each truss with 3-10d (0.131" X 3") nails. Strongbacks to be attached to walls at their outer ends or restrained by other means.
- CAUTION, Do not erect truss backwards.



November 9, 2021

WARNING - Verify design parameters and READ NOTES ON THIS AND INCLUDED MITEK REFERENCE PAGE MII-7473 rev. 5/19/2020 BEFORE USE.

Design valid for use only with MiTek® connectors. This design is based only upon parameters shown, and is for an individual building component, not a truss system. Before use, the building designer must verify the applicability of design parameters and properly incorporate this design into the overall building design. Bracing indicated is to prevent buckling of individual truss web and/or chord members only. Additional temporary and permanent bracing is always required for stability and to prevent collapse with possible personal injury and property damage. For general guidance regarding the fabrication, storage, delivery, erection and bracing of trusses and truss systems, see **ANSI/TPI1 Quality Criteria, DSB-89 and BCSI Building Component Safety Information** available from Truss Plate Institute, 2670 Crain Highway, Suite 203 Waldorf, MD 20601



818 Soundside Road
Edenton, NC 27932

Job J0322-1270	Truss F4	Truss Type Floor	Qty 4	Ply 1	Lot 5 Cypress Road Job Reference (optional)	E16391101
-------------------	-------------	---------------------	----------	----------	--	-----------

Comtech, Inc, Fayetteville, NC - 28314,

8.430 s Aug 16 2021 MiTek Industries, Inc. Mon Nov 8 13:13:33 2021 Page 1
ID:J6aSr7qB6etazEy6hKRskZzPTZ_-zLFBRj9uwmf4g1YljdaTaDcD9Z_A6g4t5dPpbryLEMW



Scale = 1:41.8

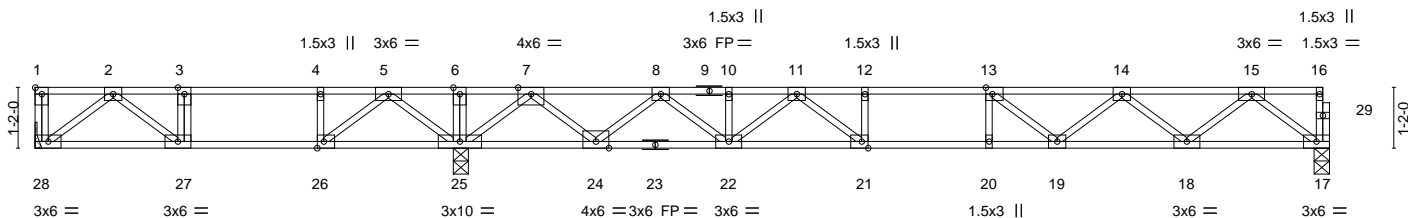

Plate Offsets (X,Y)--	[1:Edge,0-1-8], [13:0-1-8,Edge], [21:0-1-8,Edge], [26:0-1-8,Edge]
-----------------------	---

LOADING (psf)	SPACING-	CSI.	DEFL.	in (loc)	l/defl	L/d	PLATES	GRIP
TCLL 40.0	2-0-0 Plate Grip DOL 1.00	TC 0.85	Vert(LL)	-0.21 21-22	>964	480	MT20	244/190
TCDL 10.0	Lumber DOL 1.00	BC 0.86	Vert(CT)	-0.28 21-22	>719	360		
BCLL 0.0	Rep Stress Incr NO	WB 0.54	Horz(CT)	0.05 17	n/a	n/a		
BCDL 5.0	Code IRC2015/TPI2014	Matrix-S					Weight: 125 lb	FT = 20%F, 11%E

LUMBER-	BRACING-
TOP CHORD 2x4 SP No.1 (flat)	TOP CHORD Structural wood sheathing directly applied or 6-0-0 oc purlins, except end verticals.
BOT CHORD 2x4 SP No.1 (flat)	BOT CHORD Rigid ceiling directly applied or 6-0-0 oc bracing.
WEBS 2x4 SP No.3 (flat)	

REACTIONS. (size) 28=Mechanical, 25=0-3-8, 17=0-3-8
Max Grav 28=1746(LC 3), 25=1571(LC 1), 17=851(LC 7)

FORCES. (lb) - Max. Comp./Max. Ten. - All forces 250 (lb) or less except when shown.
TOP CHORD 1-28=-1403/0, 2-3=-629/297, 3-4=-629/297, 4-5=-629/297, 5-6=0/1219, 6-7=0/1219, 7-8=-1123/0, 8-10=-2493/0, 10-11=-2493/0, 11-12=-3157/0, 12-13=-3157/0, 13-14=-2793/0, 14-15=-1763/0
BOT CHORD 27-28=-55/424, 26-27=-297/629, 25-26=-730/183, 24-25=-35/277, 22-24=0/1926, 21-22=0/2904, 20-21=0/3157, 19-20=0/3157, 18-19=0/2432, 17-18=0/1059
WEBS 2-28=-532/70, 2-27=-303/257, 5-25=-823/0, 5-26=0/878, 4-26=-429/0, 15-17=-1326/0, 15-18=0/917, 14-18=-871/0, 14-19=0/501, 7-25=-1524/0, 7-24=0/1128, 8-24=-1076/0, 8-22=0/753, 11-22=-559/0, 11-21=0/624, 12-21=-277/0, 13-19=-602/0

- NOTES-**
- Unbalanced floor live loads have been considered for this design.
 - All plates are 3x4 MT20 unless otherwise indicated.
 - Plates checked for a plus or minus 1 degree rotation about its center.
 - Refer to girder(s) for truss to truss connections.
 - Recommend 2x6 strongbacks, on edge, spaced at 10-0-0 oc and fastened to each truss with 3-10d (0.131" X 3") nails. Strongbacks to be attached to walls at their outer ends or restrained by other means.
 - CAUTION, Do not erect truss backwards.

LOAD CASE(S) Standard
 1) Dead + Floor Live (balanced): Lumber Increase=1.00, Plate Increase=1.00
 Uniform Loads (plf)
 Vert: 17-28=-10, 1-16=-100
 Concentrated Loads (lb)
 Vert: 1=-1350



November 9, 2021

WARNING - Verify design parameters and READ NOTES ON THIS AND INCLUDED MITTEK REFERENCE PAGE MII-7473 rev. 5/19/2020 BEFORE USE.
 Design valid for use only with MiTek® connectors. This design is based only upon parameters shown, and is for an individual building component, not a truss system. Before use, the building designer must verify the applicability of design parameters and properly incorporate this design into the overall building design. Bracing indicated is to prevent buckling of individual truss web and/or chord members only. Additional temporary and permanent bracing is always required for stability and to prevent collapse with possible personal injury and property damage. For general guidance regarding the fabrication, storage, delivery, erection and bracing of trusses and truss systems, see ANS/TP11 Quality Criteria, DSB-89 and BCSI Building Component Safety Information available from Truss Plate Institute, 2670 Crain Highway, Suite 203 Waldorf, MD 20601



Job J0322-1270	Truss F4A	Truss Type Floor Girder	Qty 1	Ply 1	Lot 5 Cypress Road Job Reference (optional)	E16391102
-------------------	--------------	----------------------------	----------	----------	--	-----------

Comtech, Inc., Fayetteville, NC - 28314,

8.430 s Aug 16 2021 MiTek Industries, Inc. Mon Nov 8 13:13:34 2021 Page 1
ID:J6aSr?qB6etazEy6hKRskZzPTZ_-RXpaf2AWh4nxlB7yHL5i6R8QyJ?r5R0JH8M7JyLEMV

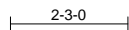
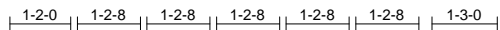

Scale = 1:41.5

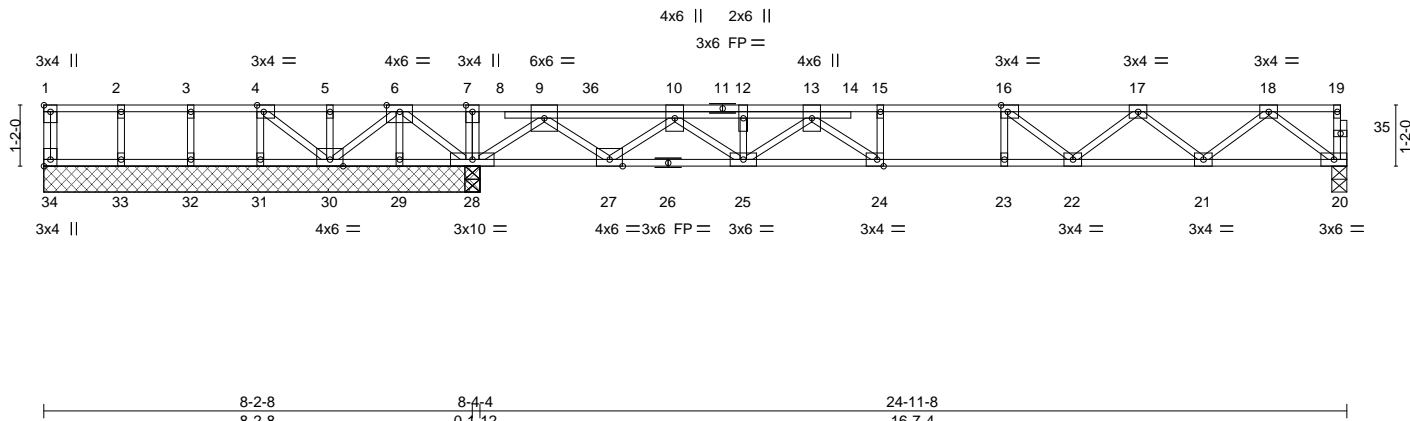

Plate Offsets (X,Y)-- [1:Edge,0-1-8], [4:0-1-8,Edge], [16:0-1-8,Edge], [24:0-1-8,Edge], [34:Edge,0-1-8]

LOADING (psf)	SPACING-	CSI.	DEFL.	PLATES	GRIP
TCLL 40.0	2-0-0	TC 0.72	in (loc) l/defl L/d	MT20	244/190
TCDL 10.0	Plate Grip DOL 1.00	BC 0.88	Vert(LL) -0.18 22-23 >999 480		
BCLL 0.0	Lumber DOL 1.00	WB 0.66	Vert(CT) -0.24 22-23 >825 360		
BCDL 5.0	Rep Stress Incr NO	Matrix-S	Horz(CT) 0.03 20 n/a n/a		
	Code IRC2015/TPI2014			Weight: 134 lb	FT = 20%F, 11%E

LUMBER-

TOP CHORD 2x4 SP No.1 (flat)
BOT CHORD 2x4 SP No.1 (flat)
WEBS 2x4 SP No.3 (flat)

BRACING-

TOP CHORD Structural wood sheathing directly applied or 6-0-0 oc purlins, except end verticals.
BOT CHORD Rigid ceiling directly applied or 10-0-0 oc bracing. Except: 6-0-0 oc bracing: 29-30,28-29,27-28.

REACTIONS.

All bearings 8-4-4 except (jt=length) 20=0-3-8.
(lb) - Max Uplift All uplift 100 lb or less at joint(s) except 29=-516(LC 4), 30=-346(LC 4), 31=-239(LC 4)
Max Grav All reactions 250 lb or less at joint(s) 34, 30, 31, 32, 33 except 28=2681(LC 1), 28=2681(LC 1), 20=773(LC 4)

FORCES.

(lb) - Max. Comp./Max. Ten. - All forces 250 (lb) or less except when shown.
TOP CHORD 4-5=0/372, 5-6=0/372, 6-7=0/2805, 7-9=0/2806, 9-10=-255/233, 10-12=-1747/0, 12-13=-1747/0, 13-15=-2589/0, 15-16=-2589/0, 16-17=-2406/0, 17-18=-1570/0
BOT CHORD 29-30=-1225/0, 28-29=-1225/0, 27-28=-1194/0, 25-27=0/1076, 24-25=0/2211, 23-24=0/2589, 22-23=0/2589, 21-22=0/2158, 20-21=0/952
WEBS 6-28=-1983/0, 6-29=0/505, 6-30=0/1101, 4-30=-472/0, 4-31=0/251, 9-28=-2137/0, 9-27=0/1383, 10-27=-1347/0, 10-25=0/837, 18-20=-1191/0, 18-21=0/804, 17-21=-766/0, 17-22=0/375, 16-22=-401/0, 13-25=-579/0, 13-24=0/628, 15-24=-253/0

NOTES-

- Unbalanced floor live loads have been considered for this design.
- All plates are 1.5x3 MT20 unless otherwise indicated.
- Plates checked for a plus or minus 1 degree rotation about its center.
- Provide mechanical connection (by others) of truss to bearing plate capable of withstanding 516 lb uplift at joint 29, 346 lb uplift at joint 30 and 239 lb uplift at joint 31.
- Recommend 2x6 strongbacks, on edge, spaced at 10-0-0 oc and fastened to each truss with 3-10d (0.131" X 3") nails. Strongbacks to be attached to walls at their outer ends or restrained by other means.
- CAUTION, Do not erect truss backwards.
- Hanger(s) or other connection device(s) shall be provided sufficient to support concentrated load(s) 407 lb down at 10-5-12 on top chord. The design/selection of such connection device(s) is the responsibility of others.
- In the LOAD CASE(S) section, loads applied to the face of the truss are noted as front (F) or back (B).

LOAD CASE(S) Standard

- Dead + Floor Live (balanced): Lumber Increase=1.00, Plate Increase=1.00
Uniform Loads (plf)
Vert: 20-34=-10, 1-19=-100
Concentrated Loads (lb)
Vert: 36=-327(B)



November 9, 2021

WARNING - Verify design parameters and READ NOTES ON THIS AND INCLUDED MITTEK REFERENCE PAGE MII-7473 rev. 5/19/2020 BEFORE USE.
Design valid for use only with MiTek® connectors. This design is based only upon parameters shown, and is for an individual building component, not a truss system. Before use, the building designer must verify the applicability of design parameters and properly incorporate this design into the overall building design. Bracing indicated is to prevent buckling of individual truss web and/or chord members only. Additional temporary and permanent bracing is always required for stability and to prevent collapse with possible personal injury and property damage. For general guidance regarding the fabrication, storage, delivery, erection and bracing of trusses and truss systems, see **ANSI/TPI1 Quality Criteria, DSB-89 and BCSI Building Component Safety Information** available from Truss Plate Institute, 2670 Crain Highway, Suite 203 Waldorf, MD 20601



818 Soundside Road
Edenton, NC 27932

Job J0322-1270	Truss F5	Truss Type Floor	Qty 6	Ply 1	Lot 5 Cypress Road Job Reference (optional)	E16391103
-------------------	-------------	---------------------	----------	----------	--	-----------

Comtech, Inc, Fayetteville, NC - 28314,

8.430 s Aug 16 2021 MiTek Industries, Inc. Mon Nov 8 13:13:36 2021 Page 1
ID:J6aSr?qB6etazEy6hKRSkZzPTZ_-NwwK4kBmDh1fXVHK0I8ABsEm8m05J1pJnbdtCAyLEMT

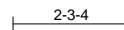

Scale = 1:41.8

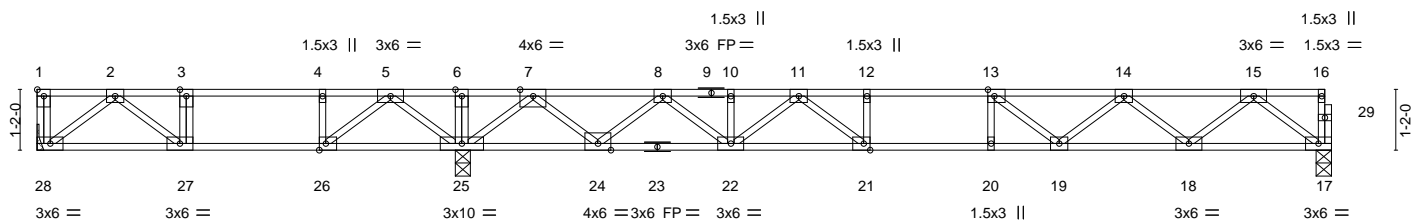

	8-2-4	8-2-8	24-11-8
	8-2-4	0-0-4	16-9-0
Plate Offsets (X,Y)--	[1:Edge,0-1-8], [13:0-1-8,Edge], [21:0-1-8,Edge], [26:0-1-8,Edge]		

LOADING (psf)	SPACING-	CSI.	DEFL.	in (loc)	l/defl	L/d	PLATES	GRIP
TCLL 40.0	Plate Grip DOL 1.00	TC 0.74	Vert(LL) -0.21	21-22	>964	480	MT20	244/190
TCDL 10.0	Lumber DOL 1.00	BC 0.78	Vert(CT) -0.28	21-22	>719	360		
BCLL 0.0	Rep Stress Incr YES	WB 0.54	Horz(CT) 0.05	17	n/a	n/a		
BCDL 5.0	Code IRC2015/TPI2014	Matrix-S					Weight: 125 lb	FT = 20%F, 11%E

LUMBER-	BRACING-
TOP CHORD 2x4 SP No.1(flat)	TOP CHORD Structural wood sheathing directly applied or 6-0-0 oc purlins, except end verticals.
BOT CHORD 2x4 SP No.1(flat)	BOT CHORD Rigid ceiling directly applied or 6-0-0 oc bracing.
WEBS 2x4 SP No.3(flat)	

REACTIONS. (size) 28=Mechanical, 25=0-3-8, 17=0-3-8
 Max Uplift 28=-14(LC 4)
 Max Grav 28=396(LC 3), 25=1571(LC 1), 17=851(LC 7)

FORCES. (lb) - Max. Comp./Max. Ten. - All forces 250 (lb) or less except when shown.
 TOP CHORD 2-3=-629/297, 3-4=-629/297, 4-5=-629/297, 5-6=0/1219, 6-7=0/1219, 7-8=-1123/0, 8-10=-2493/0, 10-11=-2493/0, 11-12=-3157/0, 12-13=-3157/0, 13-14=-2793/0, 14-15=-1763/0
 BOT CHORD 27-28=-56/423, 26-27=-297/629, 25-26=-730/184, 24-25=-34/277, 22-24=0/1927, 21-22=0/2904, 20-21=0/3157, 19-20=0/3157, 18-19=0/2432, 17-18=0/1059
 WEBS 2-28=-531/70, 2-27=-302/259, 5-25=-823/0, 5-26=0/878, 4-26=-429/0, 15-17=-1326/0, 15-18=0/917, 14-18=-871/0, 14-19=0/501, 7-25=-1524/0, 7-24=0/1128, 8-24=-1076/0, 8-22=0/753, 11-22=-559/0, 11-21=0/624, 12-21=-277/0, 13-19=-603/0

- NOTES-**
- Unbalanced floor live loads have been considered for this design.
 - All plates are 3x4 MT20 unless otherwise indicated.
 - Plates checked for a plus or minus 1 degree rotation about its center.
 - Refer to girder(s) for truss to truss connections.
 - Provide mechanical connection (by others) of truss to bearing plate capable of withstanding 14 lb uplift at joint 28.
 - Recommend 2x6 strongbacks, on edge, spaced at 10-0-0 oc and fastened to each truss with 3-10d (0.131" X 3") nails. Strongbacks to be attached to walls at their outer ends or restrained by other means.
 - CAUTION, Do not erect truss backwards.



November 9,2021

Job J0322-1270	Truss F6	Truss Type Floor	Qty 2	Ply 1	Lot 5 Cypress Road Job Reference (optional)	E16391104
-------------------	-------------	---------------------	----------	----------	--	-----------

Comtech, Inc., Fayetteville, NC - 28314,

8.430 s Aug 16 2021 MiTek Industries, Inc. Mon Nov 8 13:13:36 2021 Page 1

ID:J6aSr?qB6etazEy6hKRSkZzPTZ_-NwwK4kBmDh1fXVHKO8ABsErcm8_J6jnbdtCAyLEMT

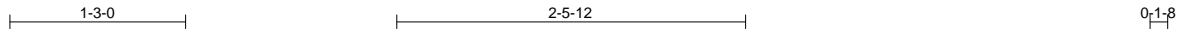

Scale = 1:15.4

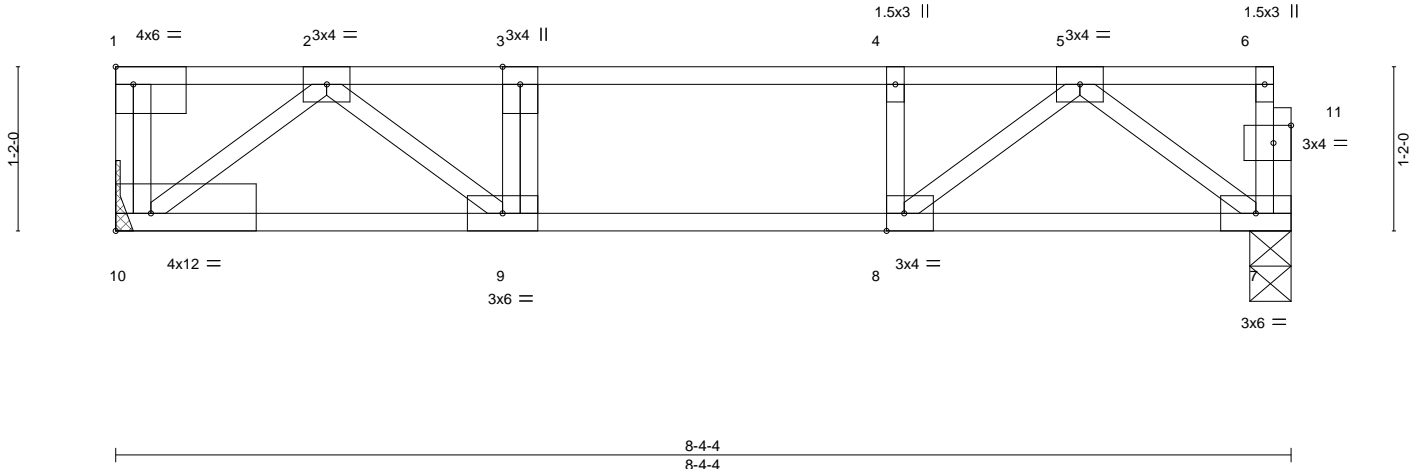

Plate Offsets (X,Y)-- [1:Edge,0-1-8], [8:0-1-8,Edge], [10:Edge,0-1-8], [11:0-1-8,0-1-8]

LOADING (psf)	SPACING-	2-0-0	CSI.	DEFL.	in	(loc)	l/defl	L/d	PLATES	GRIP
TCLL 40.0	Plate Grip DOL	1.00	TC 0.39	Vert(LL)	-0.04	9-10	>999	480	MT20	244/190
TCDL 10.0	Lumber DOL	1.00	BC 0.27	Vert(CT)	-0.05	9-10	>999	360		
BCLL 0.0	Rep Stress Incr	NO	WB 0.22	Horz(CT)	0.01	7	n/a	n/a		
BCDL 5.0	Code IRC2015/TPI2014		Matrix-S						Weight: 43 lb	FT = 20%F, 11%E

LUMBER-
TOP CHORD 2x4 SP No.1(flat)
BOT CHORD 2x4 SP No.1(flat)
WEBS 2x4 SP No.3(flat)

BRACING-
TOP CHORD Structural wood sheathing directly applied or 6-0-0 oc purlins, except end verticals.
BOT CHORD Rigid ceiling directly applied or 10-0-0 oc bracing.

REACTIONS. (size) 10=Mechanical, 7=0-3-8
Max Grav 10=3846(LC 1), 7=440(LC 1)

FORCES. (lb) - Max. Comp./Max. Ten. - All forces 250 (lb) or less except when shown.
TOP CHORD 1-10=-3459/0, 2-3=-821/0, 3-4=-821/0, 4-5=-821/0
BOT CHORD 9-10=0/493, 8-9=0/821, 7-8=0/489
WEBS 2-10=-619/0, 2-9=0/460, 5-7=-609/0, 5-8=0/469

- NOTES-**
- Unbalanced floor live loads have been considered for this design.
 - Plates checked for a plus or minus 1 degree rotation about its center.
 - Refer to girder(s) for truss to truss connections.
 - Recommend 2x6 strongbacks, on edge, spaced at 10-0-0 oc and fastened to each truss with 3-10d (0.131" X 3") nails. Strongbacks to be attached to walls at their outer ends or restrained by other means.
 - CAUTION, Do not erect truss backwards.

LOAD CASE(S) Standard
1) Dead + Floor Live (balanced): Lumber Increase=1.00, Plate Increase=1.00
Uniform Loads (plf)
Vert: 7-10=-10, 1-6=-100
Concentrated Loads (lb)
Vert: 1=-3400



November 9, 2021

WARNING - Verify design parameters and READ NOTES ON THIS AND INCLUDED MITEK REFERENCE PAGE MII-7473 rev. 5/19/2020 BEFORE USE.
Design valid for use only with MiTek® connectors. This design is based only upon parameters shown, and is for an individual building component, not a truss system. Before use, the building designer must verify the applicability of design parameters and properly incorporate this design into the overall building design. Bracing indicated is to prevent buckling of individual truss web and/or chord members only. Additional temporary and permanent bracing is always required for stability and to prevent collapse with possible personal injury and property damage. For general guidance regarding the fabrication, storage, delivery, erection and bracing of trusses and truss systems, see **ANSI/TPI1 Quality Criteria, DSB-89 and BCSI Building Component Safety Information** available from Truss Plate Institute, 2670 Crain Highway, Suite 203 Waldorf, MD 20601



Job J0322-1270	Truss F7	Truss Type Floor	Qty 1	Ply 1	Lot 5 Cypress Road Job Reference (optional)	E16391105
-------------------	-------------	---------------------	----------	----------	--	-----------

Comtech, Inc, Fayetteville, NC - 28314,

8.430 s Aug 16 2021 MiTek Industries, Inc. Mon Nov 8 13:13:37 2021 Page 1
ID:J6aSr?qB6etazEy6hKRSkZzPTZ_-r6UiH4CP__AW9frXyTfPk3m6SAYY2cdTOFN0kdyLEMS

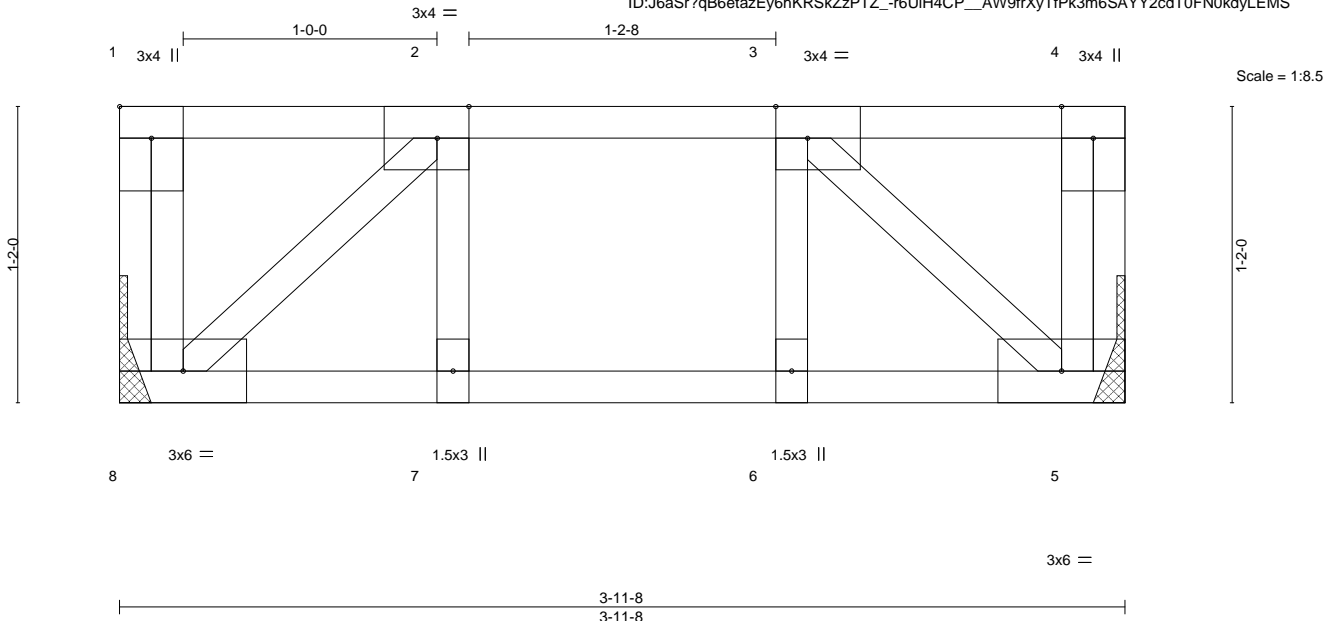

Plate Offsets (X,Y)--		[1:Edge,0-1-8], [2:0-1-8,Edge], [3:0-1-8,Edge]							
LOADING (psf)	SPACING-	2-0-0	CSI.	DEFL.	in (loc)	l/defl	L/d	PLATES	GRIP
TCLL 40.0	Plate Grip DOL 1.00		TC 0.06	Vert(LL) -0.00	7	>999	480	MT20	244/190
TCDL 10.0	Lumber DOL 1.00		BC 0.06	Vert(CT) -0.00	7	>999	360		
BCLL 0.0	Rep Stress Incr YES		WB 0.05	Horz(CT) 0.00	5	n/a	n/a		
BCDL 5.0	Code IRC2015/TPI2014		Matrix-S					Weight: 24 lb	FT = 20%F, 11%E

LUMBER-
TOP CHORD 2x4 SP No.1 (flat)
BOT CHORD 2x4 SP No.1 (flat)
WEBS 2x4 SP No.3 (flat)

BRACING-
TOP CHORD Structural wood sheathing directly applied or 3-11-8 oc purlins, except end verticals.
BOT CHORD Rigid ceiling directly applied or 10-0-0 oc bracing.

REACTIONS. (size) 8=Mechanical, 5=Mechanical
Max Grav 8=204(LC 1), 5=204(LC 1)

FORCES. (lb) - Max. Comp./Max. Ten. - All forces 250 (lb) or less except when shown.

NOTES-

- 1) Unbalanced floor live loads have been considered for this design.
- 2) Plates checked for a plus or minus 1 degree rotation about its center.
- 3) Refer to girder(s) for truss to truss connections.
- 4) Recommend 2x6 strongbacks, on edge, spaced at 10-0-0 oc and fastened to each truss with 3-10d (0.131" X 3") nails. Strongbacks to be attached to walls at their outer ends or restrained by other means.



November 9, 2021

WARNING - Verify design parameters and READ NOTES ON THIS AND INCLUDED MITEK REFERENCE PAGE MII-7473 rev. 5/19/2020 BEFORE USE.
Design valid for use only with MiTek® connectors. This design is based only upon parameters shown, and is for an individual building component, not a truss system. Before use, the building designer must verify the applicability of design parameters and properly incorporate this design into the overall building design. Bracing indicated is to prevent buckling of individual truss web and/or chord members only. Additional temporary and permanent bracing is always required for stability and to prevent collapse with possible personal injury and property damage. For general guidance regarding the fabrication, storage, delivery, erection and bracing of trusses and truss systems, see **ANSI/TPI1 Quality Criteria, DSB-89 and BCSI Building Component Safety Information** available from Truss Plate Institute, 2670 Crain Highway, Suite 203 Waldorf, MD 20601



Job J0322-1270	Truss FG1	Truss Type Floor Girder	Qty 1	Ply 1	Lot 5 Cypress Road Job Reference (optional)	E16391106
-------------------	--------------	----------------------------	----------	----------	--	-----------

Comtech, Inc. Fayetteville, NC - 28314.

8.430 s Aug 16 2021 MiTek Industries, Inc. Mon Nov 8 13:13:38 2021 Page 1
ID:J6aSr?qB6etazEy6hKRSkZzPTZ_-JI24UQD1111nmoQIWAeHHJHLaur2ecEv6aH3yLEMR

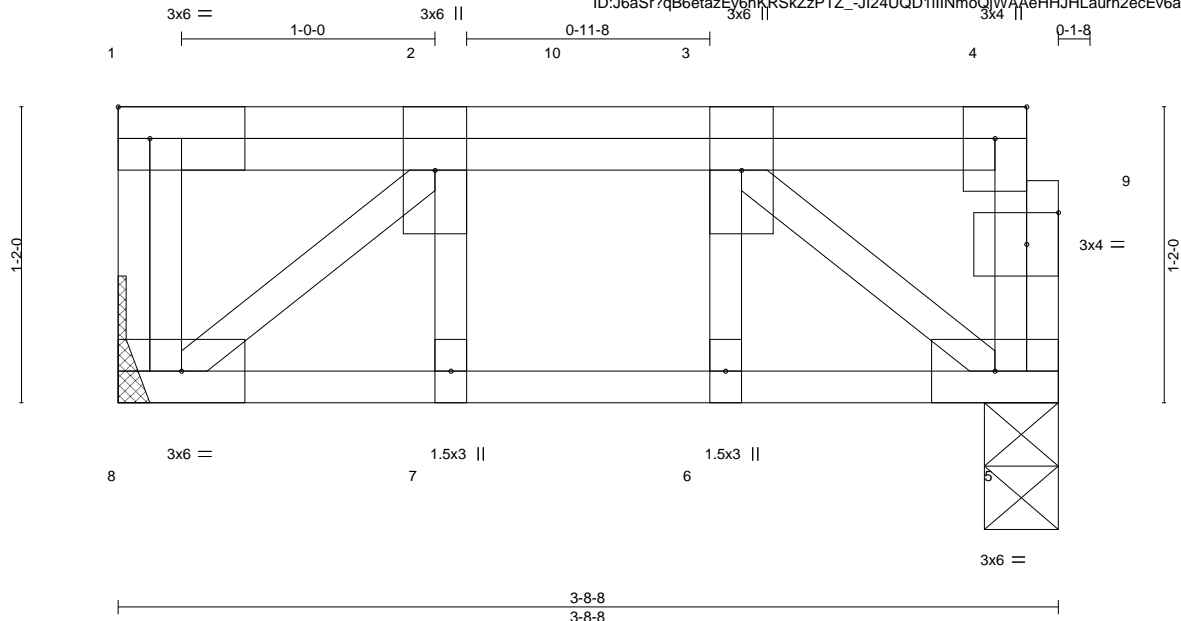

Scale = 1:8.6

Plate Offsets (X,Y)-- [9:0-1-8,0-1-8]

LOADING (psf)	SPACING-	CSI.	DEFL.	in (loc)	l/defl	L/d	PLATES	GRIP
TCLL 40.0	2-0-0	TC 0.05	Vert(LL) -0.00	7	>999	480	MT20	244/190
TCDL 10.0	Lumber DOL 1.00	BC 0.06	Vert(CT) -0.00	7	>999	360		
BCLL 0.0	Rep Stress Incr NO	WB 0.07	Horz(CT) 0.00	5	n/a	n/a		
BCDL 5.0	Code IRC2015/TPI2014	Matrix-S					Weight: 27 lb	FT = 20%F, 11%E

LUMBER-

TOP CHORD 2x4 SP No.1 (flat)
BOT CHORD 2x4 SP No.1 (flat)
WEBS 2x4 SP No.3 (flat)

BRACING-

TOP CHORD Structural wood sheathing directly applied or 3-8-8 oc purlins, except end verticals.
BOT CHORD Rigid ceiling directly applied or 10-0-0 oc bracing.

REACTIONS.

(size) 8=Mechanical, 5=0-3-8
Max Grav 8=242(LC 1), 5=236(LC 1)

FORCES.

(lb) - Max. Comp./Max. Ten. - All forces 250 (lb) or less except when shown.

WEBS 2-8=-294/0, 3-5=-291/0

NOTES-

- 1) Unbalanced floor live loads have been considered for this design.
- 2) Plates checked for a plus or minus 1 degree rotation about its center.
- 3) Refer to girder(s) for truss to truss connections.
- 4) Recommend 2x6 strongbacks, on edge, spaced at 10-0-0 oc and fastened to each truss with 3-10d (0.131" X 3") nails. Strongbacks to be attached to walls at their outer ends or restrained by other means.
- 5) CAUTION, Do not erect truss backwards.
- 6) Hanger(s) or other connection device(s) shall be provided sufficient to support concentrated load(s) 122 lb down at 1-10-4 on top chord. The design/selection of such connection device(s) is the responsibility of others.
- 7) In the LOAD CASE(S) section, loads applied to the face of the truss are noted as front (F) or back (B).

LOAD CASE(S) Standard

1) Dead + Floor Live (balanced): Lumber Increase=1.00, Plate Increase=1.00

Uniform Loads (plf)

Vert: 5-8=-10, 1-4=-100

Concentrated Loads (lb)

Vert: 10=-104(F)



November 9, 2021

WARNING - Verify design parameters and READ NOTES ON THIS AND INCLUDED MITTEK REFERENCE PAGE MII-7473 rev. 5/19/2020 BEFORE USE.

Design valid for use only with MiTek® connectors. This design is based only upon parameters shown, and is for an individual building component, not a truss system. Before use, the building designer must verify the applicability of design parameters and properly incorporate this design into the overall building design. Bracing indicated is to prevent buckling of individual truss web and/or chord members only. Additional temporary and permanent bracing is always required for stability and to prevent collapse with possible personal injury and property damage. For general guidance regarding the fabrication, storage, delivery, erection and bracing of trusses and truss systems, see **ANSI/TPI1 Quality Criteria, DSB-89 and BCSI Building Component Safety Information** available from Truss Plate Institute, 2670 Crain Highway, Suite 203 Waldorf, MD 20601



818 Soundside Road
Edenton, NC 27932

Job J0322-1270	Truss FG2	Truss Type Floor Girder	Qty 1	Ply 1	Lot 5 Cypress Road Job Reference (optional)	E16391107
-------------------	--------------	----------------------------	----------	----------	--	-----------

Comtech, Inc. Fayetteville, NC - 28314,

8.430 s Aug 16 2021 MiTek Industries, Inc. Mon Nov 8 13:38 2021 Page 1

ID:J6aSr?gB6etazEY6hKRSkZzPTZ_-JI24UQD1IIIIINmQIWAeHHJFkarVn1EcEv6aH3yLEMR

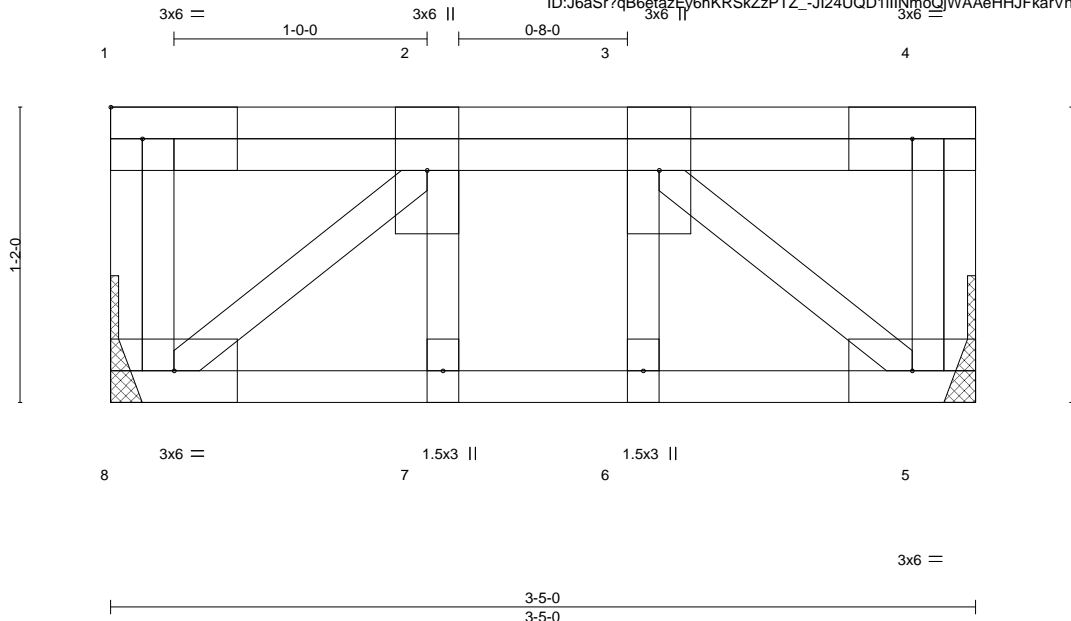

Scale = 1:8.6

LOADING (psf)	SPACING- 2-0-0	CSI.	DEFL. in (loc) l/defl L/d	PLATES	GRIP
TCLL 40.0	Plate Grip DOL 1.00	TC 0.16	Vert(LL) -0.01 7 >999 480	MT20	244/190
TCDL 10.0	Lumber DOL 1.00	BC 0.21	Vert(CT) -0.01 7 >999 360		
BCLL 0.0	Rep Stress Incr NO	WB 0.16	Horz(CT) 0.00 5 n/a n/a		
BCDL 5.0	Code IRC2015/TPI2014	Matrix-S		Weight: 26 lb	FT = 20%F, 11%E

LUMBER-

TOP CHORD 2x4 SP No.1(flat)
 BOT CHORD 2x4 SP No.1(flat)
 WEBS 2x4 SP No.3(flat)

BRACING-

TOP CHORD Structural wood sheathing directly applied or 3-5-0 oc purlins, except end verticals.
 BOT CHORD Rigid ceiling directly applied or 10-0-0 oc bracing.

REACTIONS.

(size) 8=Mechanical, 5=Mechanical
 Max Grav 8=596(LC 1), 5=427(LC 1)

FORCES.

(lb) - Max. Comp./Max. Ten. - All forces 250 (lb) or less except when shown.
 TOP CHORD 2-3=-528/0
 BOT CHORD 7-8=0/528, 6-7=0/528, 5-6=0/528
 WEBS 2-8=-684/0, 3-5=-684/0

NOTES-

- 1) Unbalanced floor live loads have been considered for this design.
- 2) Plates checked for a plus or minus 1 degree rotation about its center.
- 3) Refer to girder(s) for truss to truss connections.
- 4) Recommend 2x6 strongbacks, on edge, spaced at 10-0-0 oc and fastened to each truss with 3-10d (0.131" X 3") nails. Strongbacks to be attached to walls at their outer ends or restrained by other means.
- 5) Hanger(s) or other connection device(s) shall be provided sufficient to support concentrated load(s) 705 lb down at 1-6-12 on top chord. The design/selection of such connection device(s) is the responsibility of others.
- 6) In the LOAD CASE(S) section, loads applied to the face of the truss are noted as front (F) or back (B).

LOAD CASE(S) Standard

- 1) Dead + Floor Live (balanced): Lumber Increase=1.00, Plate Increase=1.00
 Uniform Loads (plf)
 Vert: 5-8=-10, 1-4=-100
 Concentrated Loads (lb)
 Vert: 2=-675(B)



November 9, 2021

WARNING - Verify design parameters and READ NOTES ON THIS AND INCLUDED MITTEK REFERENCE PAGE MII-7473 rev. 5/19/2020 BEFORE USE.

Design valid for use only with MiTek® connectors. This design is based only upon parameters shown, and is for an individual building component, not a truss system. Before use, the building designer must verify the applicability of design parameters and properly incorporate this design into the overall building design. Bracing indicated is to prevent buckling of individual truss web and/or chord members only. Additional temporary and permanent bracing is always required for stability and to prevent collapse with possible personal injury and property damage. For general guidance regarding the fabrication, storage, delivery, erection and bracing of trusses and truss systems, see **ANSI/TPI1 Quality Criteria, DSB-89 and BCSI Building Component Safety Information** available from Truss Plate Institute, 2670 Crain Highway, Suite 203 Waldorf, MD 20601



818 Soundside Road
 Edenton, NC 27932

Symbols

PLATE LOCATION AND ORIENTATION

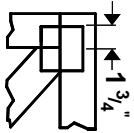

Center plate on joint unless x, y offsets are indicated. Dimensions are in ft-in-sixteenths. Apply plates to both sides of truss and fully embed teeth.

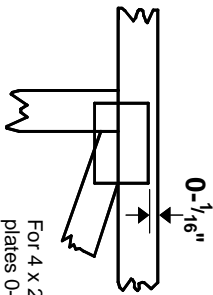

For 4 x 2 orientation, locate plates 0- $\frac{1}{16}$ " from outside edge of truss.

— This symbol indicates the required direction of slots in connector plates.

* Plate location details available in **MITek 20/20** software or upon request.

PLATE SIZE

4 X 4

The first dimension is the plate width measured perpendicular to slots. Second dimension is the length parallel to slots.

LATERAL BRACING LOCATION



Indicated by symbol shown and/or by text in the bracing section of the output. Use T or I bracing if indicated.

BEARING

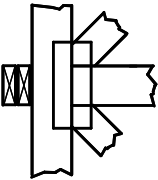

Indicates location where bearings (supports) occur. Icons vary but reaction section indicates joint number where bearings occur. Min size shown is for crushing only.

Industry Standards:

ANSI/TP1: National Design Specification for Metal Plate Connected Wood Truss Construction.
DSB-89: Design Standard for Bracing, Building Component Safety Information, Guide to Good Practice for Handling, Installing & Bracing of Metal Plate Connected Wood Trusses.

Numbering System

6-4-8 dimensions shown in ft-in-sixteenths (Drawings not to scale)

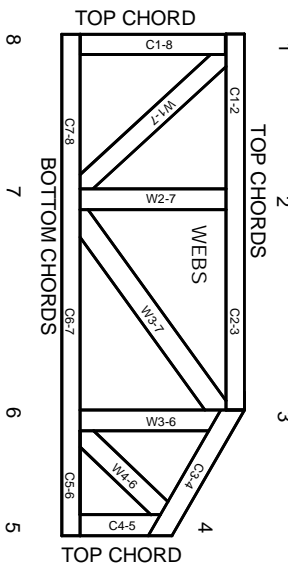

JOINTS ARE GENERALLY NUMBERED/LETTERED CLOCKWISE AROUND THE TRUSS STARTING AT THE JOINT FARTHEST TO THE LEFT.

CHORDS AND WEBS ARE IDENTIFIED BY END JOINT NUMBERS/LETTERS.

PRODUCT CODE APPROVALS

ICC-ES Reports:

ESR-1311, ESR-1352, ESR 1988
ER-3907, ESR-2362, ESR-1397, ESR-3282

Trusses are designed for wind loads in the plane of the truss unless otherwise shown.

Lumber design values are in accordance with ANSI/TP1 section 6.3 These truss designs rely on lumber values established by others.

© 2012 MITek® All Rights Reserved

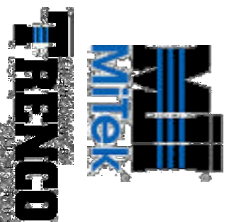

MITek Engineering Reference Sheet: Mill-7473 rev. 5/19/2020

General Safety Notes

Failure to Follow Could Cause Property Damage or Personal Injury

1. Additional stability bracing for truss system, e.g. diagonal or X-bracing, is always required. See BCSI.
2. Truss bracing must be designed by an engineer. For wide truss spacing, individual lateral braces themselves may require bracing, or alternative Tor I bracing should be considered.
3. Never exceed the design loading shown and never stack materials on inadequately braced trusses.
4. Provide copies of this truss design to the building designer, erection supervisor, property owner and all other interested parties.
5. Cut members to bear tightly against each other.
6. Place plates on each face of truss at each joint and embed fully. Knots and wane at joint locations are regulated by ANSI/TP1.
7. Design assumes trusses will be suitably protected from the environment in accord with ANSI/TP1.
8. Unless otherwise noted, moisture content of lumber shall not exceed 19% at time of fabrication.
9. Unless expressly noted, this design is not applicable for use with fire retardant, preservative treated, or green lumber.
10. Camber is a non-structural consideration and is the responsibility of truss fabricator. General practice is to camber for dead load deflection.
11. Plate type, size, orientation and location dimensions indicated are minimum plating requirements.
12. Lumber used shall be of the species and size, and in all respects, equal to or better than that specified.
13. Top chords must be sheathed or purlins provided at spacing indicated on design.
14. Bottom chords require lateral bracing at 10 ft. spacing, or less, if no ceiling is installed, unless otherwise noted.
15. Connections not shown are the responsibility of others.
16. Do not cut or alter truss member or plate without prior approval of an engineer.
17. Install and load vertically unless indicated otherwise.
18. Use of green or treated lumber may pose unacceptable environmental, health or performance risks. Consult with project engineer before use.
19. Review all portions of this design (front, back, words and pictures) before use. Reviewing pictures alone is not sufficient.
20. Design assumes manufacture in accordance with ANSI/TP1 Quality Criteria.
21. The design does not take into account any dynamic or other loads other than those expressly stated.