

**Trenco**  
818 Soundside Rd  
Edenton, NC 27932

Re: 22020120-A  
Hunt Residence-Roof

The truss drawing(s) referenced below have been prepared by Truss Engineering Co. under my direct supervision based on the parameters provided by Carter Components (Sanford, NC)).

Pages or sheets covered by this seal: I50710505 thru I50710516

My license renewal date for the state of North Carolina is December 31, 2022.

North Carolina COA: C-0844



March 11, 2022

Sevier, Scott

**IMPORTANT NOTE:** The seal on these truss component designs is a certification that the engineer named is licensed in the jurisdiction(s) identified and that the designs comply with ANSI/TPI 1. These designs are based upon parameters shown (e.g., loads, supports, dimensions, shapes and design codes), which were given to MiTek or TRENCO. Any project specific information included is for MiTek's or TRENCO's customers file reference purpose only, and was not taken into account in the preparation of these designs. MiTek or TRENCO has not independently verified the applicability of the design parameters or the designs for any particular building. Before use, the building designer should verify applicability of design parameters and properly incorporate these designs into the overall building design per ANSI/TPI 1, Chapter 2.

Job 22020120-A	Truss A01	Truss Type Roof Special Supported Gable	Qty 1	Ply 1	Hunt Residence-Roof Job Reference (optional)	150710505
-------------------	--------------	--	----------	----------	---	-----------

Carter Components (Sanford), Sanford, NC - 27332,

Run: 8.53 S Dec 6 2021 Print: 8.530 S Dec 6 2021 MiTek Industries, Inc. Thu Mar 10 11:54:54  
ID:RAEakwJD2gQqAa?KHy3yEzzj631-RC?PsB70Hq3NSgPqL6w3uITXbGKwRCDof7J4zJC7f

Page: 1

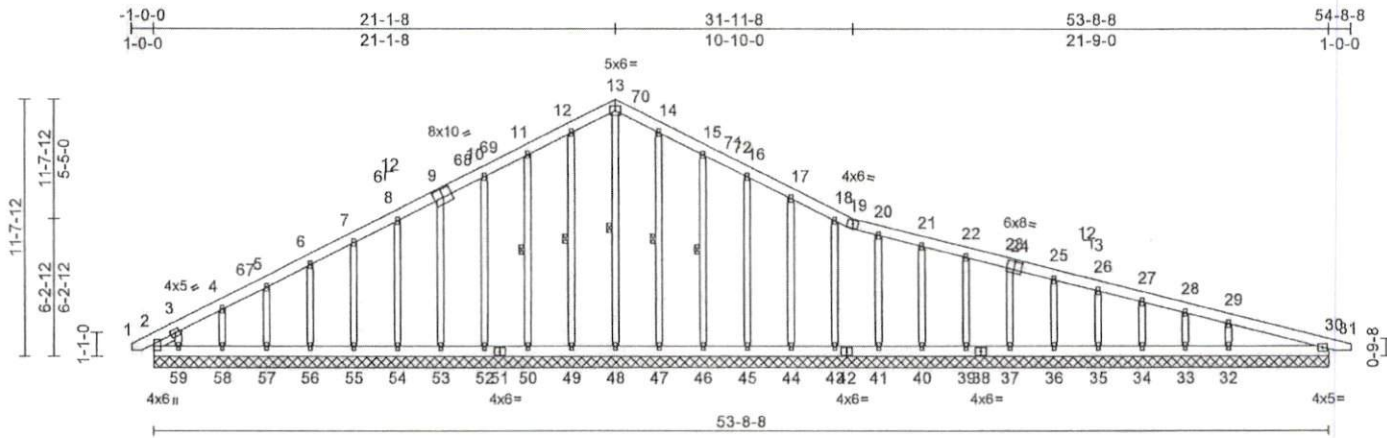

Scale = 1:96.9

Plate Offsets (X, Y): [9:0-5-0,0-4-8], [24:0-4-0,0-4-4]

Loading	(psf)	Spacing	2-0-0	CSI	DEFL	in	(loc)	l/defl	L/d	PLATES	GRIP
TCLL (roof)	20.0	Plate Grip DOL	1.15	TC	0.09	Vert(LL)	n/a	-	n/a	999	244/190
Snow (Pfl/Pg)	13.9/20.0	Lumber DOL	1.15	BC	0.08	Vert(CT)	n/a	-	n/a	999	999
TCDL	10.0	Rep Stress Incr	YES	WB	0.19	Horz(CT)	0.01	30	n/a	n/a	
BCLL	0.0*	Code	IRC2015/TPI2014	Matrix-MSH							
BCDL	10.0										

Weight: 461 lb FT = 20%

LUMBER		Max Uplift		TOP CHORD	
TOP CHORD	2x6 SP No.2	2=-40 (LC 11), 30=-5 (LC 12), 32=-37 (LC 16), 34=-11 (LC 16), 35=-9 (LC 12), 36=-9 (LC 16), 37=-9 (LC 12), 39=-9 (LC 16), 40=-9 (LC 12), 41=-15 (LC 12), 43=-24 (LC 16), 44=-19 (LC 16), 45=-20 (LC 16), 46=-27 (LC 16), 49=-1 (LC 15), 50=-25 (LC 15), 52=-19 (LC 15), 53=-19 (LC 15), 54=-20 (LC 15), 55=-19 (LC 15), 56=-19 (LC 15), 57=-20 (LC 15), 58=-17 (LC 15), 59=100 (LC 15), 60=-40 (LC 11), 64=-5 (LC 12)		1-2=0/26, 2-3=-90/48, 3-4=-136/78, 4-5=-107/75, 5-6=-94/75, 6-7=-80/111, 7-8=-67/158, 8-10=-90/254, 10-11=-106/302, 11-12=-125/355, 12-13=-135/382, 13-14=-135/370, 14-15=-125/338, 15-16=-106/286, 16-17=-90/238, 17-18=-73/191, 18-19=-44/136, 19-20=-51/133, 20-21=-42/109, 21-22=-39/88, 22-23=-40/66, 23-25=-43/44, 25-26=-46/22, 26-27=-59/8, 27-28=-82/16, 28-29=-97/15, 29-30=-141/43, 30-31=0/12	
BOT CHORD	2x6 SP No.2				
OTHERS	2x4 SP No.3 *Except* 48-13:2x4 SP No.2				
SLIDER	Left 2x4 SP No.3 -- 1-1-12				
BRACING					
TOP CHORD	Structural wood sheathing directly applied or 6-0-0 oc purlins.				
BOT CHORD	Rigid ceiling directly applied or 10-0-0 oc bracing.				
WEBS	1 Row at midpt 13-48, 12-49, 11-50, 14-47, 15-46				
REACTIONS (lb/size)	2=93/53-8-8, 30=166/53-8-8, 32=311/53-8-8, 33=58/53-8-8, 34=153/53-8-8, 35=132/53-8-8, 36=136/53-8-8, 37=135/53-8-8, 39=136/53-8-8, 40=134/53-8-8, 41=138/53-8-8, 43=139/53-8-8, 44=134/53-8-8, 45=135/53-8-8, 46=137/53-8-8, 47=135/53-8-8, 48=114/53-8-8, 49=135/53-8-8, 50=137/53-8-8, 52=135/53-8-8, 53=135/53-8-8, 54=136/53-8-8, 55=135/53-8-8, 56=136/53-8-8, 57=135/53-8-8, 58=139/53-8-8, 59=95/53-8-8, 60=93/53-8-8, 64=166/53-8-8	Max Grav	2=162 (LC 31), 30=199 (LC 2), 32=367 (LC 42), 33=69 (LC 2), 34=180 (LC 42), 35=174 (LC 40), 36=177 (LC 40), 37=176 (LC 40), 39=176 (LC 40), 40=177 (LC 40), 41=171 (LC 40), 43=165 (LC 2), 44=168 (LC 37), 45=167 (LC 37), 46=191 (LC 23), 47=200 (LC 39), 48=164 (LC 32), 49=218 (LC 22), 50=223 (LC 22), 52=193 (LC 22), 53=160 (LC 2), 54=161 (LC 41), 55=160 (LC 41), 56=160 (LC 2), 57=159 (LC 41), 58=164 (LC 2), 59=134 (LC 29), 60=162 (LC 31), 64=199 (LC 2)		
Max Horiz	2=-115 (LC 13), 60=-115 (LC 13)	FORCES	(lb) - Maximum Compression/Maximum Tension		



Continued on page 2

**WARNING - Verify design parameters and READ NOTES ON THIS AND INCLUDED MITEK REFERENCE PAGE MI-7473 rev. 5/19/2020 BEFORE USE.**  
Design valid for use only with MITek® connectors. This design is based only upon parameters shown, and is for an individual building component, not a truss system. Before use, the building designer must verify the applicability of design parameters and properly incorporate this design into the overall building design. Bracing indicated is to prevent buckling of individual truss web and/or chord members only. Additional temporary and permanent bracing is always required for stability and to prevent collapse with possible personal injury and property damage. For general guidance regarding the fabrication, storage, delivery, erection and bracing of trusses and truss systems, see ANSITP11 Quality Criteria, DSB-89 and BCSI Building Component Safety Information available from Truss Plate Institute, 2670 Crain Highway, Suite 203 Waldorf, MD 20601



818 Soundside Road  
Edenton, NC 27932

Job	Truss	Truss Type	Qty	Ply	Hunt Residence-Roof
22020120-A	A01	Roof Special Supported Gable	1	1	150710505
					Job Reference (optional)

Carter Components (Sanford), Sanford, NC - 27332,

Run: 8.53 S Dec 6 2021 Print: 8.530 S Dec 6 2021 MiTek Industries, Inc. Thu Mar 10 11:54:54  
ID:RAEAKwjD2gQqAa?KH3yEzzj631-RIC?PsB70Hq3NSgPqnL6w3ulTXbGKWrCDoi7J4zJC7f

Page: 2

**BOT CHORD** 2-59=-38/163, 58-59=-38/163,  
57-58=-38/163, 56-57=-38/163,  
55-56=-38/163, 54-55=-38/163,  
53-54=-38/163, 52-53=-38/163,  
50-52=-38/163, 49-50=-38/163,  
48-49=-38/163, 47-48=-38/163,  
46-47=-38/163, 45-46=-38/163,  
44-45=-38/163, 43-44=-38/163,  
41-43=-38/163, 40-41=-38/163,  
39-40=-38/163, 37-39=-38/163,  
36-37=-38/163, 35-36=-38/163,  
34-35=-38/163, 33-34=-38/163,  
32-33=-38/163, 30-32=-38/163

**WEBS** 13-48=-194/28, 12-49=-178/101,  
11-50=-183/156, 10-52=-153/100,  
9-53=-120/82, 8-54=-121/83, 7-55=-120/83,  
6-56=-120/83, 5-57=-120/98, 4-58=-124/149,  
3-59=-85/158, 14-47=-160/99,  
15-46=-151/156, 16-45=-127/100,  
17-44=-128/81, 18-43=-125/101,  
20-41=-131/83, 21-40=-137/64,  
22-39=-136/67, 23-37=-136/67,  
25-36=-136/67, 26-35=-137/66,  
27-34=-129/75, 28-33=-69/39,  
29-32=-246/212

**NOTES**

- 1) Unbalanced roof live loads have been considered for this design.
- 2) Wind: ASCE 7-10; Vult=130mph (3-second gust)  
Vasd=103mph; TCCL=6.0psf; BCDL=6.0psf; h=25ft;  
Cat. II; Exp B; Enclosed; MWFRS (envelope) and C-C  
Corner (3) -0-9-6 to 4-7-2, Exterior (2) 4-7-2 to 21-1-8,  
Corner (3) 21-1-8 to 26-5-15, Exterior (2) 26-5-15 to  
54-4-3 zone; cantilever left and right exposed ; end  
vertical left and right exposed; C-C for members and  
forces & MWFRS for reactions shown; Lumber  
DOL=1.60 plate grip DOL=1.33
- 3) Truss designed for wind loads in the plane of the truss  
only. For studs exposed to wind (normal to the face),  
see Standard Industry Gable End Details as applicable,  
or consult qualified building designer as per ANSI/TPI 1.
- 4) TCCL: ASCE 7-10; Pr=20.0 psf (roof live load; Lumber  
DOL=1.15 Plate DOL=1.15); Pg=20.0 psf (ground  
snow); Pf=13.9 psf (flat roof snow; Lumber DOL=1.15  
Plate DOL=1.15); Category II; Exp B; Fully Exp.;  
Ct=1.10
- 5) Unbalanced snow loads have been considered for this  
design.
- 6) This truss has been designed for greater of min roof live  
load of 12.0 psf or 2.00 times flat roof load of 13.9 psf on  
overhangs non-concurrent with other live loads.
- 7) All plates are 2x4 MT20 unless otherwise indicated.
- 8) Gable requires continuous bottom chord bearing.
- 9) Gable studs spaced at 2-0-0 oc.
- 10) \* This truss has been designed for a live load of 20.0psf  
on the bottom chord in all areas where a rectangle  
3-06-00 tall by 2-00-00 wide will fit between the bottom  
chord and any other members.



**WARNING - Verify design parameters and READ NOTES ON THIS AND INCLUDED MITEK REFERENCE PAGE MII-7473 rev. 5/19/2020 BEFORE USE.**  
Design valid for use only with MiTek® connectors. This design is based only upon parameters shown, and is for an individual building component, not  
a truss system. Before use, the building designer must verify the applicability of design parameters and properly incorporate this design into the overall  
building design. Bracing indicated is to prevent buckling of individual truss web and/or chord members only. Additional temporary and permanent bracing  
is always required for stability and to prevent collapse with possible personal injury and property damage. For general guidance regarding the  
fabrication, storage, delivery, erection and bracing of trusses and truss systems, see ANSI/TPI Quality Criteria, DSB-69 and BCSI Building Component  
Safety Information available from Truss Plate Institute, 2670 Crain Highway, Suite 203 Waldorf, MD 20601

ENGINEERING BY  
**TRENCO**  
A MiTek Affiliate

818 Soundside Road  
Edenton, NC 27932

Job 22020120-A	Truss C03	Truss Type Common Girder	Qty 1	Ply 2	Hunt Residence-Roof Job Reference (optional)	150710506
-------------------	--------------	-----------------------------	----------	----------	---	-----------

Carter Components (Sanford), Sanford, NC - 27332,

Run: 8.53 S Dec 6 2021 Print: 8.530 S Dec 6 2021 MiTek Industries, Inc. Thu Mar 10 11:55:02  
ID:zFCD5PwGHbRZ51DPDJLkLzj62n-RC?Psb70Hq3NSgPqnl6w3uITXGkWCDoI7J4zJC?I

Page: 1

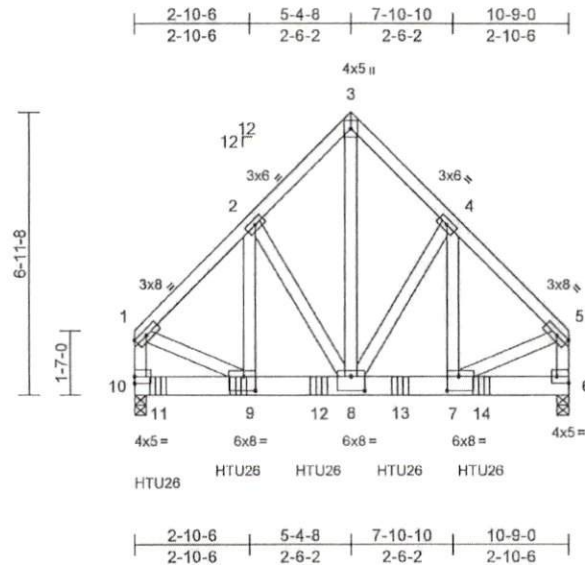

Scale = 1:52.6

Plate Offsets (X, Y): [1:0-3-7,Edge], [5:0-3-7,Edge], [6:Edge,0-2-0], [7:0-3-8,0-4-4], [8:0-4-0,0-4-4], [9:0-3-8,0-4-4]

Loading	(psf)	Spacing	2-0-0	CSI	DEFL	in	(loc)	l/defl	L/d	PLATES	GRIP	
TCLL (roof)	20.0	Plate Grip DOL	1.15	TC	0.25	Vert(LL)	-0.03	8-9	>999	240	MT20	244/190
Snow (Pf/Pg)	13.9/20.0	Lumber DOL	1.15	BC	0.53	Vert(CT)	-0.05	8-9	>999	180		
TCDL	10.0	Rep Stress Incr	NO	WB	0.79	Horz(CT)	0.01	6	n/a	n/a		
BCLL	0.0*	Code	IRC2015/TPI2014	Matrix-MSH								
BCDL	10.0											
											Weight: 185 lb	FT = 20%

**LUMBER**

TOP CHORD 2x4 SP No.2  
BOT CHORD 2x6 SP No.2  
WEBS 2x4 SP No.3 \*Except\* 10-1,6-5:2x4 SP No.2

**BRACING**

TOP CHORD Structural wood sheathing directly applied or 6-0-0 oc purlins, except end verticals.  
BOT CHORD Rigid ceiling directly applied or 10-0-0 oc bracing.

REACTIONS (lb/size) 6=3520/0-3-8, 10=4390/0-3-8  
Max Horiz 10=141 (LC 6)  
Max Grav 6=4137 (LC 2), 10=5188 (LC 2)

**FORCES**

(lb) - Maximum Compression/Maximum Tension  
TOP CHORD 1-2=-3618/0, 2-3=-2883/0, 3-4=-2883/0, 4-5=-3614/0, 1-10=-3725/0, 5-6=-3731/0  
BOT CHORD 9-10=-86/254, 8-9=0/2503, 7-8=0/2501, 6-7=0/148  
WEBS 1-9=0/2585, 5-7=0/2606, 2-9=0/1182, 2-8=-910/0, 3-8=0/3827, 4-8=-922/0, 4-7=0/1174

**NOTES**

- 2-ply truss to be connected together with 10d (0.131"x3") nails as follows:  
Top chords connected as follows: 2x4 - 1 row at 0-9-0 oc.  
Bottom chords connected as follows: 2x6 - 2 rows staggered at 0-5-0 oc.  
Web connected as follows: 2x4 - 1 row at 0-9-0 oc.
- All loads are considered equally applied to all plies, except if noted as front (F) or back (B) face in the LOAD CASE(S) section. Ply to ply connections have been provided to distribute only loads noted as (F) or (B), unless otherwise indicated.
- Unbalanced roof live loads have been considered for this design.

- Wind: ASCE 7-10; Vult=130mph (3-second gust) Vasd=103mph; TCCL=6.0psf; BCDL=6.0psf; h=25ft; Cat. II; Exp B; Enclosed; MWFRS (envelope); cantilever left and right exposed; end vertical left and right exposed; Lumber DOL=1.60 plate grip DOL=1.33
- TCLL: ASCE 7-10; Pr=20.0 psf (roof live load; Lumber DOL=1.15 Plate DOL=1.15); Pg=20.0 psf (ground snow); Pf=13.9 psf (flat roof snow; Lumber DOL=1.15 Plate DOL=1.15); Category II; Exp B; Fully Exp.; Ct=1.10
- \* This truss has been designed for a live load of 20.0psf on the bottom chord in all areas where a rectangle 3-06-00 tall by 2-00-00 wide will fit between the bottom chord and any other members.
- One H2.5A Simpson Strong-Tie connectors recommended to connect truss to bearing walls due to UPLIFT at jt(s) 10 and 6. This connection is for uplift only and does not consider lateral forces.
- This truss is designed in accordance with the 2015 International Residential Code sections R502.11.1 and R802.10.2 and referenced standard ANSI/TPI 1.
- Use Simpson Strong-Tie HTU26 (20-10d Girder, 11-10dx1 1/2 Truss, Single Ply Girder) or equivalent spaced at 2-0-0 oc max. starting at 0-7-0 from the left end to 8-7-0 to connect truss(es) to front face of bottom chord.
- Fill all nail holes where hanger is in contact with lumber.

**LOAD CASE(S)** Standard

- Dead + Snow (balanced): Lumber increase=1.15, Plate Increase=1.15  
Uniform Loads (lb/ft)  
Vert: 1-3=-48, 3-5=-48, 6-10=-20  
Concentrated Loads (lb)  
Vert: 9=-1400 (F), 11=-1406 (F), 12=-1400 (F), 13=-1400 (F), 14=-1596 (F)

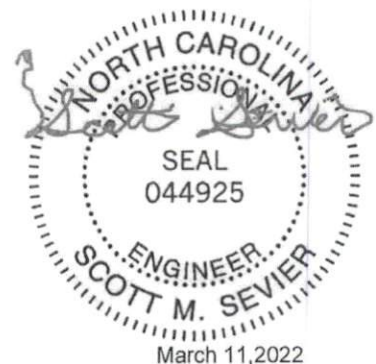

**WARNING** - Verify design parameters and READ NOTES ON THIS AND INCLUDED MITEK REFERENCE PAGE MII-7473 rev. 5/19/2020 BEFORE USE.  
Design valid for use only with MiTek connectors. This design is based only upon parameters shown, and is for an individual building component, not a truss system. Before use, the building designer must verify the applicability of design parameters and properly incorporate this design into the overall building design. Bracing indicated is to prevent buckling of individual truss web and/or chord members only. Additional temporary and permanent bracing is always required for stability and to prevent collapse with possible personal injury and property damage. For general guidance regarding the fabrication, storage, delivery, erection and bracing of trusses and truss systems, see ANSITPI Quality Criteria, DSB-89 and BCSI Building Component Safety Information available from Truss Plate Institute, 2670 Crain Highway, Suite 203 Waldorf, MD 20601

ENGINEERING BY  
**TRENCO**  
A MiTek Affiliate

818 Soundside Road  
Edenton, NC 27932

Job 22020120-A	Truss C02	Truss Type Common	Qty 5	Ply 1	Hunt Residence-Roof Job Reference (optional)	I50710507
-------------------	--------------	----------------------	----------	----------	---	-----------

Carter Components (Sanford), Sanford, NC - 27332,

Run: 8.53 S Dec 6 2021 Print: 8.530 S Dec 6 2021 MiTek Industries, Inc. Thu Mar 10 11:55:01  
ID:4UyJG11IDMx7dQwd\_TGmkVzj62r-RIC7PsB70Hq3NSgPqL8w3uITXbGKwRCDoi7J4zJC7f

Page: 1

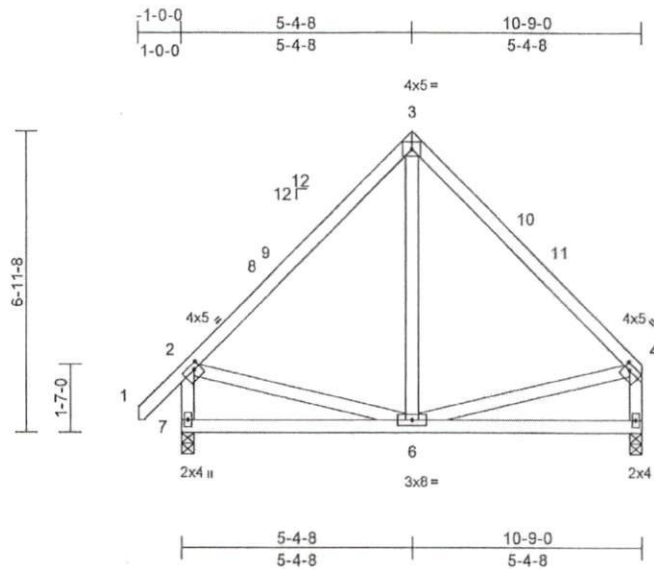

Scale = 1:49.4

Plate Offsets (X, Y): [2:0-1-12,0-1-8], [4:0-1-12,0-1-8]

Loading	(psf)	Spacing	2-0-0	CSI	DEFL	in	(loc)	l/defl	L/d	PLATES	GRIP	
TCLL (roof)	20.0	Plate Grip DOL	1.15	TC	0.48	Vert(LL)	0.00	6	>999	240	MT20	244/190
Snow (P/Pg)	13.9/20.0	Lumber DOL	1.15	BC	0.17	Vert(CT)	-0.02	5-6	>999	180		
TCDL	10.0	Rep Stress Incr	YES	WB	0.05	Horz(CT)	0.00	5	n/a	n/a		
BCLL	0.0*	Code	IRC2015/TPI2014	Matrix-MSH								
BCDL	10.0											

Weight: 69 lb FT = 20%

#### LUMBER

TOP CHORD 2x4 SP No.2  
BOT CHORD 2x4 SP No.2  
WEBS 2x4 SP No.3

#### BRACING

TOP CHORD Structural wood sheathing directly applied or 6-0-0 oc purlins, except end verticals.  
BOT CHORD Rigid ceiling directly applied or 10-0-0 oc bracing.

#### REACTIONS

(lb/size) 5=351/0-3-8, 7=409/0-3-8  
Max Horiz 7=157 (LC 10)  
Max Grav 5=415 (LC 2), 7=487 (LC 2)

#### FORCES

(lb) - Maximum Compression/Maximum Tension

TOP CHORD 1-2=0/58, 2-3=-377/112, 3-4=-370/105,  
2-7=-440/148, 4-5=-368/105  
BOT CHORD 6-7=-177/211, 5-6=-68/113  
WEBS 3-6=0/122, 2-6=-58/168, 4-6=-34/161

#### NOTES

- Unbalanced roof live loads have been considered for this design.
- Wind: ASCE 7-10; Vult=130mph (3-second gust) Vasd=103mph; TCCL=6.0psf; BCCL=6.0psf; h=25ft; Cat. II; Exp B; Enclosed; MWFRS (envelope) and C-C Exterior (2) 0-11-4 to 2-0-12, Interior (1) 2-0-12 to 5-4-8, Exterior (2) 5-4-8 to 8-4-8, Interior (1) 8-4-8 to 10-7-4 zone; cantilever left and right exposed; end vertical left and right exposed; C-C for members and forces & MWFRS for reactions shown; Lumber DOL=1.60 plate grip DOL=1.33
- TCLL: ASCE 7-10; Pr=20.0 psf (roof live load; Lumber DOL=1.15 Plate DOL=1.15); Pg=20.0 psf (ground snow); Pf=13.9 psf (flat roof snow; Lumber DOL=1.15 Plate DOL=1.15); Category II; Exp B; Fully Exp.; Ct=1.10

- This truss has been designed for greater of min roof live load of 12.0 psf or 2.00 times flat roof load of 13.9 psf on overhangs non-concurrent with other live loads.
  - \* This truss has been designed for a live load of 20.0psf on the bottom chord in all areas where a rectangle 3-06-00 tall by 2-00-00 wide will fit between the bottom chord and any other members.
  - One H2.5A Simpson Strong-Tie connectors recommended to connect truss to bearing walls due to UPLIFT at jt(s) 7 and 5. This connection is for uplift only and does not consider lateral forces.
  - This truss is designed in accordance with the 2015 International Residential Code sections R502.11.1 and R802.10.2 and referenced standard ANSI/TPI 1.
- LOAD CASE(S) Standard



WARNING - Verify design parameters and READ NOTES ON THIS AND INCLUDED MITTEK REFERENCE PAGE MI-7473 rev. 5/19/2020 BEFORE USE.

Design valid for use only with MiTek® connectors. This design is based only upon parameters shown, and is for an individual building component, not a truss system. Before use, the building designer must verify the applicability of design parameters and properly incorporate this design into the overall building design. Bracing indicated is to prevent buckling of individual truss web and/or chord members only. Additional temporary and permanent bracing is always required for stability and to prevent collapse with possible personal injury and property damage. For general guidance regarding the fabrication, storage, delivery, erection and bracing of trusses and truss systems, see ANSITPH Quality Criteria, DSB-89 and BCSI Building Component Safety Information available from Truss Plate Institute, 2670 Crain Highway, Suite 203 Waldorf, MD 20601

ENGINEERING BY  
**TRENCO**  
A MiTek Affiliate

818 Soundside Road  
Edenton, NC 27932

Job 22020120-A	Truss C01	Truss Type Common Supported Gable	Qty 1	Ply 1	Hunt Residence-Roof Job Reference (optional)	150710508
-------------------	--------------	--------------------------------------	----------	----------	---	-----------

Carter Components (Sanford), Sanford, NC - 27332,

Run: 8.53 S Dec 6 2021 Print: 8.530 S Dec 6 2021 MiTek Industries, Inc. Thu Mar 10 11:55:01  
ID: d\PK2hs7S3pG7GLRQm\XBHJz62s-RIC?PsB70Hq3NSgPqnL8w3uITXbGKWCDoi7J4zC7f

Page: 1

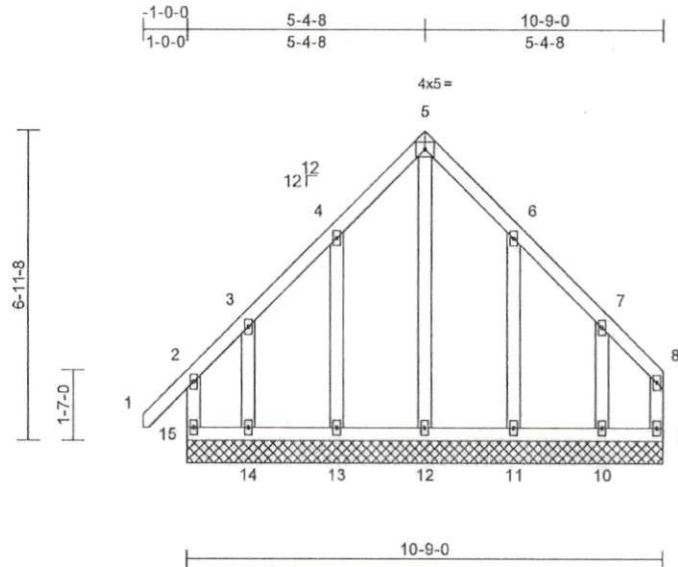

Scale = 1:48

Loading	(psf)	Spacing	2-0-0	CSI	DEFL	in	(loc)	l/defl	L/d	PLATES	GRIP	
TCLL (roof)	20.0	Plate Grip DOL	1.15	TC	0.15	Vert(LL)	n/a	-	n/a	999	MT20	244/190
Snow (PflPg)	13.9/20.0	Lumber DOL	1.15	BC	0.09	Vert(CT)	n/a	-	n/a	999		
TCDL	10.0	Rep Stress Incr	YES	WB	0.24	Horz(CT)	0.00	9	n/a	n/a		
BCLL	0.0*	Code	IRC2015/TPI2014	Matrix-MR								
BCDL	10.0											
											Weight: 74 lb	FT = 20%

**LUMBER**

TOP CHORD 2x4 SP No.2  
BOT CHORD 2x4 SP No.2  
WEBS 2x4 SP No.3  
OTHERS 2x4 SP No.3

**BRACING**

TOP CHORD Structural wood sheathing directly applied or 6-0-0 oc purlins, except end verticals.  
BOT CHORD Rigid ceiling directly applied or 6-0-0 oc bracing.

**REACTIONS** (lb/size)

9=27/10-9-0, 10=120/10-9-0,  
11=145/10-9-0, 12=124/10-9-0,  
13=148/10-9-0, 14=90/10-9-0,  
15=106/10-9-0  
Max Horiz 15=157 (LC 10)  
Max Uplift 9=112 (LC 10), 10=110 (LC 9),  
11=55 (LC 14), 13=53 (LC 13),  
14=137 (LC 10), 15=126 (LC 9)  
Max Grav 9=137 (LC 11), 10=224 (LC 26),  
11=181 (LC 26), 12=184 (LC 14),  
13=183 (LC 25), 14=203 (LC 11),  
15=204 (LC 26)

**FORCES** (lb) - Maximum Compression/Maximum Tension

TOP CHORD 2-15=-155/107, 1-2=0/58, 2-3=-118/118,  
3-4=-105/144, 4-5=-196/254, 5-6=-196/254,  
6-7=-104/146, 7-8=-99/97, 8-9=-87/75  
BOT CHORD 14-15=-77/68, 13-14=-77/68, 12-13=-77/68,  
11-12=-77/68, 10-11=-77/68, 9-10=-77/68  
WEBS 5-12=-291/157, 4-13=-172/132,  
3-14=-154/141, 6-11=-171/131,  
7-10=-173/133

**NOTES**

1) Unbalanced roof live loads have been considered for this design.

- Wind: ASCE 7-10; Vult=130mph (3-second gust) Vasd=103mph; TC DL=6.0psf; BCDL=6.0psf; h=25ft; Cat. II; Exp B; Enclosed; MWFRS (envelope) and C-C Corner (3) -0-11-4 to 2-0-12, Exterior (2) 2-0-12 to 5-4-8, Corner (3) 5-4-8 to 8-4-8, Exterior (2) 8-4-8 to 10-7-4 zone; cantilever left and right exposed; end vertical left and right exposed; C-C for members and forces & MWFRS for reactions shown; Lumber DOL=1.60 plate grip DOL=1.33
- Truss designed for wind loads in the plane of the truss only. For studs exposed to wind (normal to the face), see Standard Industry Gable End Details as applicable, or consult qualified building designer as per ANSI/TPI 1.
- TCLL: ASCE 7-10; Pr=20.0 psf (roof live load; Lumber DOL=1.15 Plate DOL=1.15); Pg=20.0 psf (ground snow); Pf=13.9 psf (flat roof snow; Lumber DOL=1.15 Plate DOL=1.15); Category II; Exp B; Fully Exp.; Ct=1.10
- This truss has been designed for greater of min roof live load of 12.0 psf or 2.00 times flat roof load of 13.9 psf on overhangs non-concurrent with other live loads.
- All plates are 2x4 MT20 unless otherwise indicated.
- Gable requires continuous bottom chord bearing.
- Truss to be fully sheathed from one face or securely braced against lateral movement (i.e. diagonal web).
- Gable studs spaced at 2-0-0 oc.
- \* This truss has been designed for a live load of 20.0psf on the bottom chord in all areas where a rectangle 3-06-00 tall by 2-00-00 wide will fit between the bottom chord and any other members.



**WARNING - Verify design parameters and READ NOTES ON THIS AND INCLUDED MITTEK REFERENCE PAGE MII-7473 rev. 5/19/2020 BEFORE USE.**  
Design valid for use only with MiTek® connectors. This design is based only upon parameters shown, and is for an individual building component, not a truss system. Before use, the building designer must verify the applicability of design parameters and properly incorporate this design into the overall building design. Bracing indicated is to prevent buckling of individual truss web and/or chord members only. Additional temporary and permanent bracing is always required for stability and to prevent collapse with possible personal injury and property damage. For general guidance regarding the fabrication, storage, delivery, erection and bracing of trusses and truss systems, see ANSI/TPI1 Quality Criteria, DSB-89 and BCSI Building Component Safety Information available from Truss Plate Institute, 2670 Crain Highway, Suite 203 Waldorf, MD 20681



818 Soundside Road  
Edenlon, NC 27932

Job 22020120-A	Truss B02	Truss Type Common	Qty 8	Ply 1	Hunt Residence-Roof Job Reference (optional)	150710509
-------------------	--------------	----------------------	----------	----------	---	-----------

Carter Components (Sanford), Sanford, NC - 27332,

Run: 8.53 S Dec 6 2021 Print: 8.530 S Dec 6 2021 MITek Industries, Inc. Thu Mar 10 11:55:01  
ID:65ryrLrVhlpN6mF12E1e4zj621-RIC?PsB70Hq3NSgPqnL8w3ulTXbGKWCDoi7J4zJC?f

Page: 1

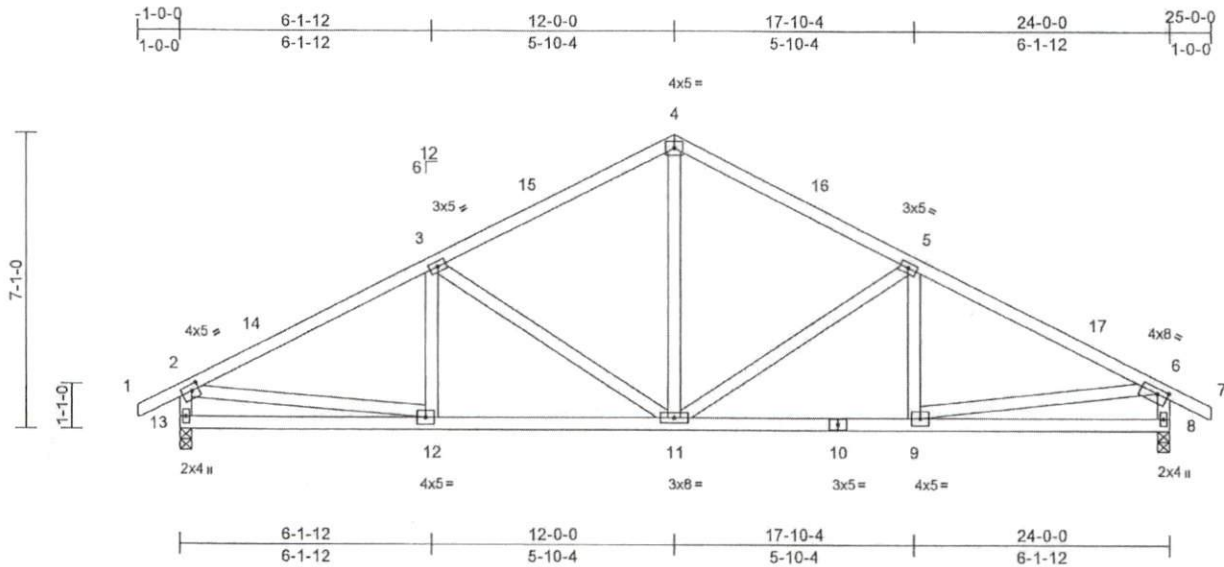

Scale = 1:51.4

Plate Offsets (X, Y): [2:0-2-0,0-1-12], [6:0-3-0,0-1-8]

Loading	(psf)	Spacing	2-0-0	CSI	DEFL	in	(loc)	l/defl	L/d	PLATES	GRIP	
TCLL (roof)	20.0	Plate Grip DOL	1.15	TC	0.50	Vert(LL)	-0.04	11-12	>999	240	MT20	244/190
Snow (Pf/Pg)	13.9/20.0	Lumber DOL	1.15	BC	0.38	Vert(CT)	-0.10	11-12	>999	180		
TCDL	10.0	Rep Stress Incr	YES	WB	0.40	Horz(CT)	0.03	8	n/a	n/a		
BCLL	0.0*	Code	IRC2015/TPI2014	Matrix-MSH								
BCDL	10.0											
											Weight: 138 lb	FT = 20%

**LUMBER**

TOP CHORD 2x4 SP No.2  
BOT CHORD 2x4 SP No.2  
WEBS 2x4 SP No.3

**BRACING**

TOP CHORD Structural wood sheathing directly applied or 4-9-11 oc purlins, except end verticals.  
BOT CHORD Rigid ceiling directly applied or 10-0-0 oc bracing.

**REACTIONS**

(lb/size) 8=856/0-3-8, 13=856/0-3-8  
Max Horiz 13=94 (LC 14)  
Max Uplift 8=-6 (LC 16), 13=-6 (LC 15)  
Max Grav 8=1015 (LC 2), 13=1015 (LC 2)

**FORCES**

(lb) - Maximum Compression/Maximum Tension

TOP CHORD 1-2=0/37, 2-3=-1372/179, 3-4=-1032/204, 4-5=-1032/204, 5-6=-1372/179, 6-7=0/37, 2-13=-955/214, 6-8=-955/214  
BOT CHORD 12-13=-74/248, 11-12=-85/1156, 9-11=-68/1156, 8-9=-35/209

**WEBS**

6-9=-38/957, 3-12=-17/83, 3-11=-407/105, 4-11=-39/527, 5-11=-407/105, 5-9=-17/83, 2-12=-39/957

**NOTES**

- 1) Unbalanced roof live loads have been considered for this design.
- 2) Wind: ASCE 7-10; Vult=130mph (3-second gust) Vasd=103mph; TCDL=6.0psf; BCDL=6.0psf; h=25ft; Cat. II; Exp B; Enclosed; MWFRS (envelope) and C-C Exterior (2) 0-11-9 to 2-0-7, Interior (1) 2-0-7 to 12-0-0, Exterior (2) 12-0-0 to 15-0-0, Interior (1) 15-0-0 to 24-11-9 zone; cantilever left and right exposed; end vertical left and right exposed; C-C for members and forces & MWFRS for reactions shown; Lumber DOL=1.60 plate grip DOL=1.33

- 3) TCLL: ASCE 7-10; Pr=20.0 psf (roof live load; Lumber DOL=1.15 Plate DOL=1.15); Pg=20.0 psf (ground snow); Pf=13.9 psf (flat roof snow; Lumber DOL=1.15 Plate DOL=1.15); Category II; Exp B; Fully Exp.; Ct=1.10
- 4) Unbalanced snow loads have been considered for this design.
- 5) This truss has been designed for greater of min roof live load of 12.0 psf or 2.00 times flat roof load of 13.9 psf on overhangs non-concurrent with other live loads.
- 6) \* This truss has been designed for a live load of 20.0psf on the bottom chord in all areas where a rectangle 3-06-00 tall by 2-00-00 wide will fit between the bottom chord and any other members.
- 7) One RT7A MITek connectors recommended to connect truss to bearing walls due to UPLIFT at j(s) 13 and 8. This connection is for uplift only and does not consider lateral forces.
- 8) This truss is designed in accordance with the 2015 International Residential Code sections R502.11.1 and R802.10.2 and referenced standard ANSI/TPI 1.

LOAD CASE(S) Standard



**WARNING** - Verify design parameters and READ NOTES ON THIS AND INCLUDED MITEK REFERENCE PAGE MII-7473 rev. 5/19/2020 BEFORE USE. Design valid for use only with MITek connectors. This design is based only upon parameters shown, and is for an individual building component, not a truss system. Before use, the building designer must verify the applicability of design parameters and properly incorporate this design into the overall building design. Bracing indicated is to prevent buckling of individual truss web and/or chord members only. Additional temporary and permanent bracing is always required for stability and to prevent collapse with possible personal injury and property damage. For general guidance regarding the fabrication, storage, delivery, erection and bracing of trusses and truss systems, see ANSI/TPI1 Quality Criteria, DSB-89 and BCSI Building Component Safety Information available from Truss Plate Institute, 2870 Crain Highway, Suite 203 Waldorf, MD 20601

ENGINEERING BY  
**TRENCO**  
A MITek Affiliate  
818 Soundside Road  
Edenton, NC 27932

Job 22020120-A	Truss B01	Truss Type Common Supported Gable	Qty 1	Ply 1	Hunt Residence-Roof Job Reference (optional)	I50710510
-------------------	--------------	--------------------------------------	----------	----------	---	-----------

Carter Components (Sanford), Sanford, NC - 27332,

Run: 8.53 S Dec 8 2021 Print: 8.530 S Dec 8 2021 MiTek Industries, Inc. Thu Mar 10 11:55:01  
ID:859rLrVhlpN6mF12E1e4zj6Zt-RC7?PsB70Hq3NSgPqL8w3uITXbGKW/CDol7J4zJC7f

Page: 1

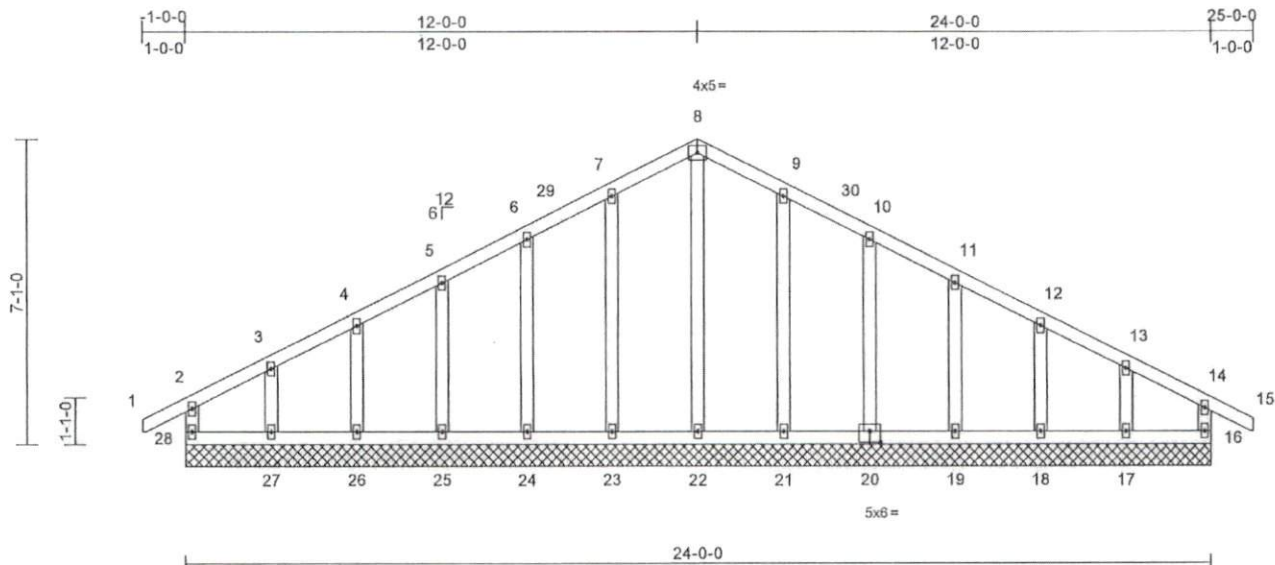

Scale = 1:49.6

Plate Offsets (X, Y): [20:0-3:0,0-3:0]

Loading	(psf)	Spacing	2-0-0	CSI	DEFL	in	(loc)	l/defl	L/d	PLATES	GRIP	
TCLL (roof)	20.0	Plate Grip DOL	1.15	TC	0.11	Vert(L/L)	n/a	-	n/a	999	MT20	244/190
Snow (Pf/Pg)	13.9/20.0	Lumber DOL	1.15	BC	0.04	Vert(CT)	n/a	-	n/a	999		
TCDL	10.0	Rep Stress Incr	YES	WB	0.14	Horz(CT)	0.00	16	n/a	n/a		
BCLL	0.0*	Code	IRC2015/TPI2014	Matrix-MR								
BCDL	10.0											
											Weight: 143 lb	FT = 20%

**LUMBER**  
 TOP CHORD 2x4 SP No.2  
 BOT CHORD 2x4 SP No.2  
 WEBS 2x4 SP No.3  
 OTHERS 2x4 SP No.3

**BRACING**  
 TOP CHORD Structural wood sheathing directly applied or 6-0-0 oc purlins, except end verticals.  
 BOT CHORD Rigid ceiling directly applied or 6-0-0 oc bracing.

**REACTIONS (lb/size)**  
 16=119/24-0-0, 17=124/24-0-0,  
 18=138/24-0-0, 19=135/24-0-0,  
 20=134/24-0-0, 21=141/24-0-0,  
 22=129/24-0-0, 23=141/24-0-0,  
 24=134/24-0-0, 25=135/24-0-0,  
 26=138/24-0-0, 27=124/24-0-0,  
 28=119/24-0-0  
 Max Horiz 28=94 (LC 14)  
 Max Uplift 16=26 (LC 12), 17=44 (LC 16),  
 18=14 (LC 16), 19=20 (LC 16),  
 20=20 (LC 16), 21=17 (LC 16),  
 23=18 (LC 15), 24=20 (LC 15),  
 25=21 (LC 15), 26=13 (LC 15),  
 27=48 (LC 15), 28=38 (LC 11)  
 Max Grav 16=147 (LC 34), 17=150 (LC 30),  
 18=164 (LC 34), 19=160 (LC 2),  
 20=159 (LC 2), 21=185 (LC 23),  
 22=158 (LC 32), 23=185 (LC 22),  
 24=159 (LC 2), 25=160 (LC 2),  
 26=164 (LC 33), 27=156 (LC 29),  
 28=147 (LC 33)

**FORCES (lb) - Maximum Compression/Maximum Tension**

**TOP CHORD**  
 2-28=-130/145, 1-2=0/37, 2-3=-58/53,  
 3-4=-43/96, 4-5=-46/143, 5-6=-62/191,  
 6-7=-79/240, 7-8=-96/284, 8-9=-96/279,  
 9-10=-79/234, 10-11=-62/185,  
 11-12=-46/137, 12-13=-33/90, 13-14=-45/42,  
 14-15=0/37, 14-16=-130/141  
**BOT CHORD**  
 27-28=-39/71, 26-27=-39/71, 25-26=-39/71,  
 24-25=-39/71, 23-24=-39/71, 22-23=-39/71,  
 21-22=-39/71, 19-21=-39/71, 18-19=-39/71,  
 17-18=-39/71, 16-17=-39/71  
**WEBS**  
 8-22=-155/11, 7-23=-145/142, 6-24=-119/96,  
 5-25=-119/82, 4-26=-124/82, 3-27=-105/102,  
 9-21=-145/142, 10-20=-119/97,  
 11-19=-119/82, 12-18=-124/81,  
 13-17=-105/104

- NOTES**
- 1) Unbalanced roof live loads have been considered for this design.
  - 2) Wind: ASCE 7-10; Vull=130mph (3-second gust) Vasd=103mph; TCCL=6.0psf; BCDL=6.0psf; h=25ft; Cat. II; Exp B; Enclosed; MWFRS (envelope) and C-C Corner (3) 0-11-9 to 2-0-0, Exterior (2) 2-0-0 to 12-0-0, Corner (3) 12-0-0 to 15-0-0, Exterior (2) 15-0-0 to 24-11-9 zone; cantilever left and right exposed; end vertical left and right exposed; C-C for members and forces & MWFRS for reactions shown; Lumber DOL=1.60 plate grip DOL=1.33
  - 3) Truss designed for wind loads in the plane of the truss only. For studs exposed to wind (normal to the face), see Standard Industry Gable End Details as applicable, or consult qualified building designer as per ANSI/TPI 1.
  - 4) TCCL: ASCE 7-10; Pr=20.0 psf (roof live load; Lumber DOL=1.15 Plate DOL=1.15); Pg=20.0 psf (ground snow); Pf=13.9 psf (flat roof snow; Lumber DOL=1.15 Plate DOL=1.15); Category II; Exp B; Fully Exp.; Ct=1.10
  - 5) Unbalanced snow loads have been considered for this design.

- 6) This truss has been designed for greater of min roof live load of 12.0 psf or 2.00 times flat roof load of 13.9 psf on overhangs non-concurrent with other live loads.
- 7) All plates are 2x4 MT20 unless otherwise indicated.
- 8) Gable requires continuous bottom chord bearing.
- 9) Truss to be fully sheathed from one face or securely braced against lateral movement (i.e. diagonal web).
- 10) Gable studs spaced at 2-0-0 oc.
- 11) \* This truss has been designed for a live load of 20.0psf on the bottom chord in all areas where a rectangle 3-06-00 tall by 2-00-00 wide will fit between the bottom chord and any other members.

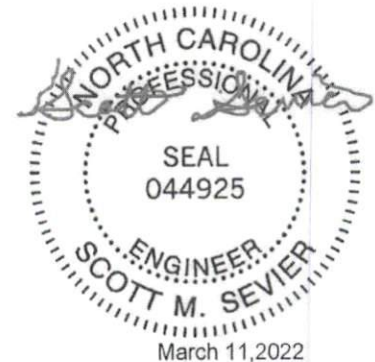

**WARNING** - Verify design parameters and READ NOTES ON THIS AND INCLUDED MITTEK REFERENCE PAGE MII-7473 rev. 5/19/2020 BEFORE USE.  
 Design valid for use only with MiTek® connectors. This design is based only upon parameters shown, and is for an individual building component, not a truss system. Before use, the building designer must verify the applicability of design parameters and properly incorporate this design into the overall building design. Bracing indicated is to prevent buckling of individual truss web and/or chord members only. Additional temporary and permanent bracing is always required for stability and to prevent collapse with possible personal injury and property damage. For general guidance regarding the fabrication, storage, delivery, erection and bracing of trusses and truss systems, see ANSI/TPI 1 Quality Criteria, D5B-89 and BCS1 Building Component Safety Information available from Truss Plate Institute, 2670 Crain Highway, Suite 203 Waldorf, MD 20601

**ENGINEERING BY**  
**TRENCO**  
 A MiTek Affiliates  
 818 Southside Road  
 Edenton, NC 27932



Job 22020120-A	Truss A07	Truss Type Common Supported Gable	Qty 1	Ply 1	Hunt Residence-Roof Job Reference (optional)	150710511
-------------------	--------------	--------------------------------------	----------	----------	---	-----------

Carier Components (Sanford), Sanford, NC - 27332,

Run: 8.53 S Dec 6 2021 Print: 8.530 S Dec 6 2021 MiTek Industries, Inc. Thu Mar 10 11:55:00  
ID:pgvHad7qtwRZYmyB2JLj36szj62u-RIC?PsB70Hq3NSgPqnL8w3uITXbGKwRCDoi7J4zJC7f

Page: 1

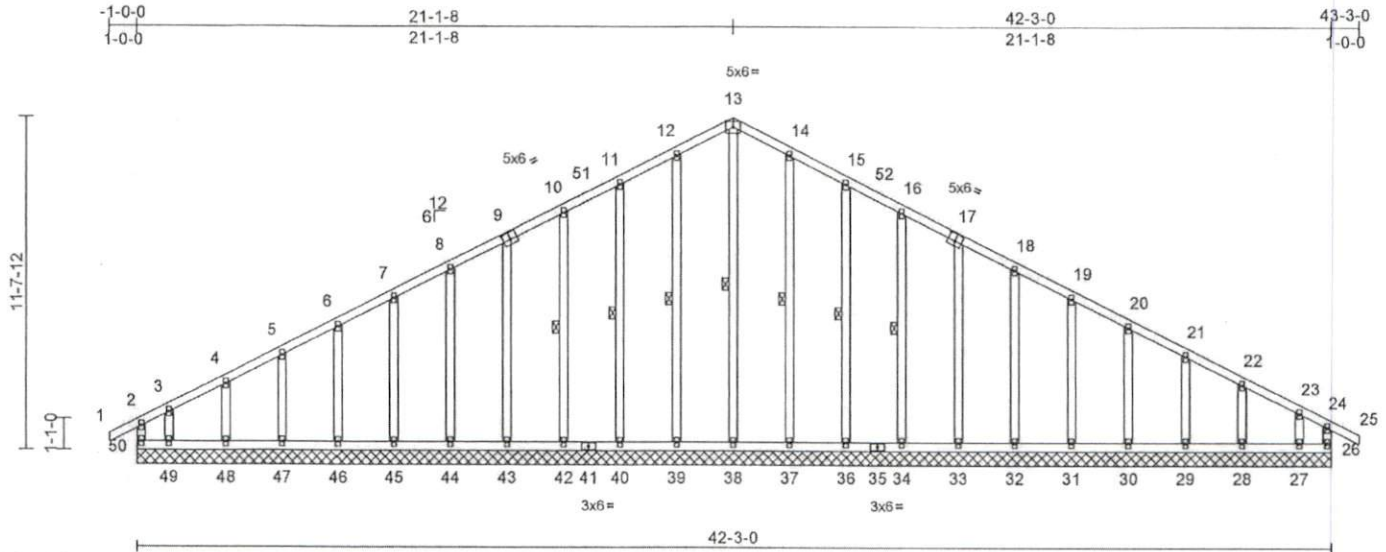

Scale = 1:75.1

Plate Offsets (X, Y): [9:0-3-0,0-3-0], [17:0-3-0,0-3-0]

Loading	(psf)	Spacing	2-0-0	CSI	DEFL	in (loc)	l/defl	L/d	PLATES	GRIP
TCLL (roof)	20.0	Plate Grip DOL	1.15	TC	0.17	Vert(LL)	n/a	-	n/a	999
Snow (Pl/Pg)	13.9/20.0	Lumber DOL	1.15	BC	0.09	Vert(CT)	n/a	-	n/a	999
TCDL	10.0	Rep Stress Incr	YES	WB	0.18	Horz(CT)	0.01	26	n/a	n/a
BCLL	0.0*	Code	IRC2015/TPI2014	Matrix-MR						
BCDL	10.0									
										Weight: 322 lb FT = 20%

**LUMBER**

TOP CHORD 2x4 SP No.2  
BOT CHORD 2x4 SP No.2  
WEBS 2x4 SP No.3  
OTHERS 2x4 SP No.3

**BRACING**

TOP CHORD Structural wood sheathing directly applied or 6-0-0 oc purlins, except end verticals.

BOT CHORD Rigid ceiling directly applied or 6-0-0 oc bracing.

WEBS 1 Row at midpt 13-38, 12-39, 11-40, 10-42, 14-37, 15-36, 16-34

**REACTIONS (lb/size)**

26=100/42-3-0, 27=80/42-3-0, 28=143/42-3-0, 29=134/42-3-0, 30=136/42-3-0, 31=135/42-3-0, 32=138/42-3-0, 33=136/42-3-0, 34=133/42-3-0, 36=135/42-3-0, 37=140/42-3-0, 38=128/42-3-0, 39=140/42-3-0, 40=135/42-3-0, 42=133/42-3-0, 43=136/42-3-0, 44=138/42-3-0, 45=135/42-3-0, 46=136/42-3-0, 47=134/42-3-0, 48=143/42-3-0, 49=80/42-3-0, 50=100/42-3-0  
Max Horiz 50=143 (LC 14)  
Max Uplift 26=39 (LC 12), 27=103 (LC 16), 28=11 (LC 16), 29=21 (LC 16), 30=19 (LC 16), 31=19 (LC 16), 32=20 (LC 16), 33=19 (LC 16), 34=18 (LC 16), 36=24 (LC 16), 37=10 (LC 16), 39=11 (LC 15), 40=23 (LC 15), 42=18 (LC 15), 43=19 (LC 15), 44=20 (LC 15), 45=19 (LC 15), 46=19 (LC 15), 47=22 (LC 15), 48=9 (LC 15), 49=125 (LC 15), 50=82 (LC 11)

**Max Grav**

26=145 (LC 29), 27=123 (LC 30), 28=169 (LC 34), 29=158 (LC 2), 30=161 (LC 34), 31=159 (LC 34), 32=163 (LC 2), 33=160 (LC 34), 34=157 (LC 2), 36=190 (LC 23), 37=209 (LC 23), 38=184 (LC 32), 39=209 (LC 22), 40=190 (LC 22), 42=157 (LC 2), 43=160 (LC 33), 44=163 (LC 2), 45=159 (LC 33), 46=161 (LC 33), 47=158 (LC 2), 48=169 (LC 33), 49=147 (LC 29), 50=179 (LC 30)

**WEBS**

13-38=279/52, 12-39=169/132, 11-40=150/123, 10-42=117/80, 9-43=120/83, 8-44=123/85, 7-45=119/82, 6-46=120/84, 5-47=118/83, 4-48=127/117, 3-49=90/134, 14-37=169/131, 15-36=150/123, 16-34=117/80, 17-33=120/83, 18-32=123/85, 19-31=119/82, 20-30=120/84, 21-29=118/83, 22-28=127/117, 23-27=77/137

**NOTES**

1) Unbalanced roof live loads have been considered for this design.

**FORCES**

(lb) - Maximum Compression/Maximum Tension

**TOP CHORD**

2-50=-139/63, 1-2=0/37, 2-3=-133/92, 3-4=-88/78, 4-5=-79/77, 5-6=-69/110, 6-7=-60/158, 7-8=-65/206, 8-10=-99/303, 10-11=-115/349, 11-12=-133/400, 12-13=-148/439, 13-14=-148/432, 14-15=-133/393, 15-16=-115/342, 16-18=-99/296, 18-19=-65/199, 19-20=-48/151, 20-21=-40/103, 21-22=-48/57, 22-23=-66/53, 23-24=-107/50, 24-25=0/37, 24-26=-124/41

**BOT CHORD**

49-50=-52/129, 48-49=-52/129, 47-48=-52/129, 46-47=-52/129, 45-46=-52/129, 44-45=-52/129, 43-44=-52/129, 42-43=-52/129, 40-42=-52/129, 39-40=-52/129, 38-39=-52/129, 37-38=-52/129, 36-37=-52/129, 34-36=-52/129, 33-34=-52/129, 32-33=-52/129, 31-32=-52/129, 30-31=-52/129, 29-30=-52/129, 28-29=-52/129, 27-28=-52/129, 26-27=-52/129

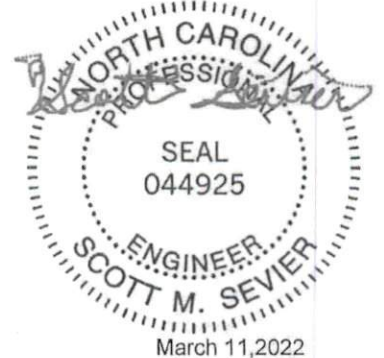

Continued on page 2

**WARNING** - Verify design parameters and READ NOTES ON THIS AND INCLUDED MITEK REFERENCE PAGE MI-7473 rev. 5/19/2020 BEFORE USE.  
Design valid for use only with MiTek® connectors. This design is based only upon parameters shown, and is for an individual building component, not a truss system. Before use, the building designer must verify the applicability of design parameters and properly incorporate this design into the overall building design. Bracing indicated is to prevent buckling of individual truss web and/or chord members only. Additional temporary and permanent bracing is always required for stability and to prevent collapse with possible personal injury and property damage. For general guidance regarding the fabrication, storage, delivery, erection and bracing of trusses and truss systems, see ANSITPH Quality Criteria, DSB-89 and BCSI Building Component Safety Information available from Truss Plate Institute, 2670 Crain Highway, Suite 203 Waldorf, MD 20601

**ENGINEERING BY**  
**TRENCO**  
A MiTek Affiliate

818 Soundside Road  
Edenton, NC 27932

Job 22020120-A	Truss A07	Truss Type Common Supported Gable	Qty 1	Ply 1	Hunt Residence-Roof I50710511 Job Reference (optional)
-------------------	--------------	--------------------------------------	----------	----------	--

Carter Components (Sanford), Sanford, NC - 27332,

Run: 8.53 S Dec 6 2021 Print: 8.530 S Dec 6 2021 MiTek Industries, Inc. Thu Mar 10 11:55:00  
ID:gvHad7qtwRZYmyB2JLj36szj62u-RIC?PsB70Hq3NSgPqntL8w3uiTXbGKwCDoi7J4zJC7f

Page: 2

- 2) Wind: ASCE 7-10; Vult=130mph (3-second gust)  
Vasd=103mph; TCCL=6.0psf; BCDL=6.0psf; h=25ft;  
Cat. II; Exp B; Enclosed; MWFRS (envelope) and C-C  
Corner (3) -0-11-9 to 3-1-8, Exterior (2) 3-1-8 to 21-1-8,  
Corner (3) 21-1-8 to 25-1-8, Exterior (2) 25-1-8 to 43-2-9  
zone; cantilever left and right exposed ; end vertical left  
and right exposed; C-C for members and forces &  
MWFRS for reactions shown; Lumber DOL=1.60 plate  
grip DOL=1.33
- 3) Truss designed for wind loads in the plane of the truss  
only. For studs exposed to wind (normal to the face),  
see Standard Industry Gable End Details as applicable,  
or consult qualified building designer as per ANSI/TPI 1.
- 4) TCCL: ASCE 7-10; Pr=20.0 psf (roof live load: Lumber  
DOL=1.15 Plate DOL=1.15); Pg=20.0 psf (ground  
snow); Pf=13.9 psf (flat roof snow: Lumber DOL=1.15  
Plate DOL=1.15); Category II; Exp B; Fully Exp.;  
Ct=1.10
- 5) Unbalanced snow loads have been considered for this  
design.
- 6) This truss has been designed for greater of min roof live  
load of 12.0 psf or 2.00 times flat roof load of 13.9 psf on  
overhangs non-concurrent with other live loads.
- 7) All plates are 2x4 MT20 unless otherwise indicated.
- 8) Gable requires continuous bottom chord bearing.
- 9) Truss to be fully sheathed from one face or securely  
braced against lateral movement (i.e. diagonal web).
- 10) Gable studs spaced at 2-0-0 oc.
- 11) \* This truss has been designed for a live load of 20.0psf  
on the bottom chord in all areas where a rectangle  
3-06-00 tall by 2-00-00 wide will fit between the bottom  
chord and any other members.



**WARNING** - Verify design parameters and READ NOTES ON THIS AND INCLUDED MITEK REFERENCE PAGE MII-7473 rev. 5/19/2020 BEFORE USE.

Design valid for use only with MiTek® connectors. This design is based only upon parameters shown, and is for an individual building component, not a truss system. Before use, the building designer must verify the applicability of design parameters and properly incorporate this design into the overall building design. Bracing indicated is to prevent buckling of individual truss web and/or chord members only. Additional temporary and permanent bracing is always required for stability and to prevent collapse with possible personal injury and property damage. For general guidance regarding the fabrication, storage, delivery, erection and bracing of trusses and truss systems, see ANSI/TPII Quality Criteria, DSB-89 and BCSI Building Component Safety Information available from Truss Plate Institute, 2670 Crain Highway, Suite 203 Waldorf, MD 20601

ENGINEERING BY  
**TRENCO**  
A MiTek Affiliate

816 Soundside Road  
Edenton, NC 27932

Job 22020120-A	Truss A06	Truss Type Common	Qty 5	Ply 1	Hunt Residence-Roof Job Reference (optional)	150710512
-------------------	--------------	----------------------	----------	----------	---	-----------

Carter Components (Sanford), Sanford, NC - 27332.

Run: 8.53 S Dec 6 2021 Print: 8.530 S Dec 6 2021 MITEK Industries, Inc. Thu Mar 10 11:54:59  
ID:1s4Tgju7L\_Brsj306uJEpwzj02p-RIC7PsB70Hq3NSgPqnL0w3uITXbGKwRCDoI7J4zJC7f

Page: 1

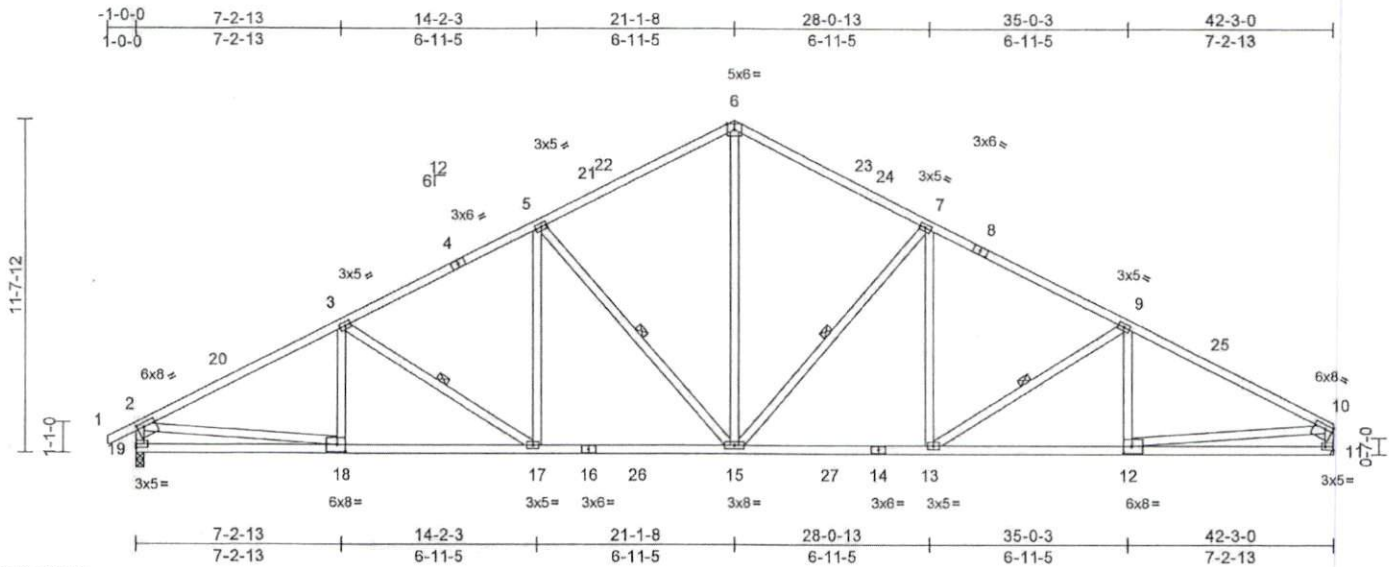

Scale = 1:74.8

Plate Offsets (X, Y): [2:0-3-0,0-1-12], [10:Edge,0-1-12], [11:Edge,0-1-8], [12:0-3-8,0-3-0], [18:0-3-8,0-3-0]

Loading	(psf)	Spacing	2-0-0	CSI	DEFL	in	(loc)	l/defl	L/d	PLATES	GRIP	
TCLL (roof)	20.0	Plate Grip DOL	1.15	TC	0.96	Vert(LL)	-0.18	13-15	>999	240	MT20	244/190
Snow (Pl/Pg)	13.9/20.0	Lumber DOL	1.15	BC	0.76	Vert(CT)	-0.37	13-15	>999	180		
TCDL	10.0	Rep Stress Incr	YES	WB	0.85	Horz(CT)	0.11	11	n/a	n/a		
BCLL	0.0*	Code	IRC2015/TPI2014	Matrix-MSH								
BCDL	10.0											

Weight: 262 lb FT = 20%

**LUMBER**

TOP CHORD 2x4 SP No.2  
 BOT CHORD 2x4 SP No.2  
 WEBS 2x4 SP No.3 \*Except\* 15-5, 15-6, 15-7:2x4 SP No.2

**BRACING**

TOP CHORD Structural wood sheathing directly applied, except end verticals.  
 BOT CHORD Rigid ceiling directly applied or 10-0-0 oc bracing.  
 WEBS 1 Row at midpl 3-17, 5-15, 7-15, 9-13

**REACTIONS**

(lb/size) 11=1420/ Mechanical, 19=1474/0-3-8  
 Max Horiz 19=145 (LC 12)  
 Max Uplift 19=-4 (LC 15)  
 Max Grav 11=1677 (LC 2), 19=1746 (LC 2)

**FORCES**

(lb) - Maximum Compression/Maximum Tension  
 TOP CHORD 1-2=0/37, 2-3=-2680/309, 3-5=-2363/343, 5-6=-1857/358, 6-7=-1857/362, 7-9=-2367/352, 9-10=-2684/324, 2-19=-1673/298, 10-11=-1805/248  
 BOT CHORD 18-19=-143/422, 17-18=-201/2309, 15-17=-135/2033, 13-15=-123/2034, 12-13=-218/2321, 11-12=-81/272  
 WEBS 2-18=-88/1965, 10-12=-138/2064, 3-18=-96/102, 3-17=-368/94, 5-17=0/375, 5-15=-729/162, 6-15=-146/1211, 7-15=-729/162, 7-13=0/381, 9-13=-382/111, 9-12=-108/108

**NOTES**

1) Unbalanced roof live loads have been considered for this design.

- Wind: ASCE 7-10; Vult=130mph (3-second gust) Vasd=103mph; TC DL=6.0psf; BCDL=6.0psf; h=25ft; Cat. II; Exp B; Enclosed; MWFRS (envelope) and C-C Exterior (2) 0-11-9 to 3-3-2, Interior (1) 3-3-2 to 21-1-8, Exterior (2) 21-1-8 to 25-4-3, Interior (1) 25-4-3 to 42-1-4 zone; cantilever left and right exposed; end vertical left and right exposed; C-C for members and forces & MWFRS for reactions shown; Lumber DOL=1.60 plate grip DOL=1.33
- TCLL: ASCE 7-10; Pr=20.0 psf (roof live load: Lumber DOL=1.15 Plate DOL=1.15); Pg=20.0 psf (ground snow); Pf=13.9 psf (flat roof snow: Lumber DOL=1.15 Plate DOL=1.15); Category II; Exp B; Fully Exp.; Ct=1.10
- Unbalanced snow loads have been considered for this design.
- This truss has been designed for greater of min roof live load of 12.0 psf or 2.00 times flat roof load of 13.9 psf on overhangs non-concurrent with other live loads.
- All plates are 3x5 MT20 unless otherwise indicated.
- \* This truss has been designed for a live load of 20.0psf on the bottom chord in all areas where a rectangle 3-06-00 tall by 2-00-00 wide will fit between the bottom chord and any other members, with BCDL = 10.0psf.
- Refer to girder(s) for truss to truss connections.
- One H2.5A Simpson Strong-Tie connectors recommended to connect truss to bearing walls due to UPLIFT at Jt(s) 19. This connection is for uplift only and does not consider lateral forces.
- This truss is designed in accordance with the 2015 International Residential Code sections R502.11.1 and R802.10.2 and referenced standard ANSI/TPI 1.

LOAD CASE(S) Standard



**WARNING** - Verify design parameters and READ NOTES ON THIS AND INCLUDED MITEK REFERENCE PAGE MII-7473 rev. 5/19/2020 BEFORE USE.

Design valid for use only with MITEK connectors. This design is based only upon parameters shown, and is for an individual building component, not a truss system. Before use, the building designer must verify the applicability of design parameters and properly incorporate this design into the overall building design. Bracing indicated is to prevent buckling of individual truss web and/or chord members only. Additional temporary and permanent bracing is always required for stability and to prevent collapse with possible personal injury and property damage. For general guidance regarding the fabrication, storage, delivery, erection and bracing of trusses and truss systems, see ANSI/TPI1 Quality Criteria, DSB-89 and BCSI Building Component Safety Information available from Truss Plate Institute, 2670 Crain Highway, Suite 203 Waldorf, MD 20601



818 Soundside Road  
Edenton, NC 27932

Job 22020120-A	Truss A05	Truss Type Common	Qty 1	Ply 1	Hunt Residence-Roof	150710513
-------------------	--------------	----------------------	----------	----------	---------------------	-----------

Carter Components (Sanford), Sanford, NC - 27332, Run: 8.53 S Dec 8 2021 Print: 8.530 S Dec 6 2021 MiTek Industries, Inc. Thu Mar 10 11:54:59 Page: 1  
 ID:1s4Tgju?l\_Brsj306uJEpwzj62p-RIC?PsB70Hq3NSgPqnL8w3uIXbGKwRCD07J4zJC7I

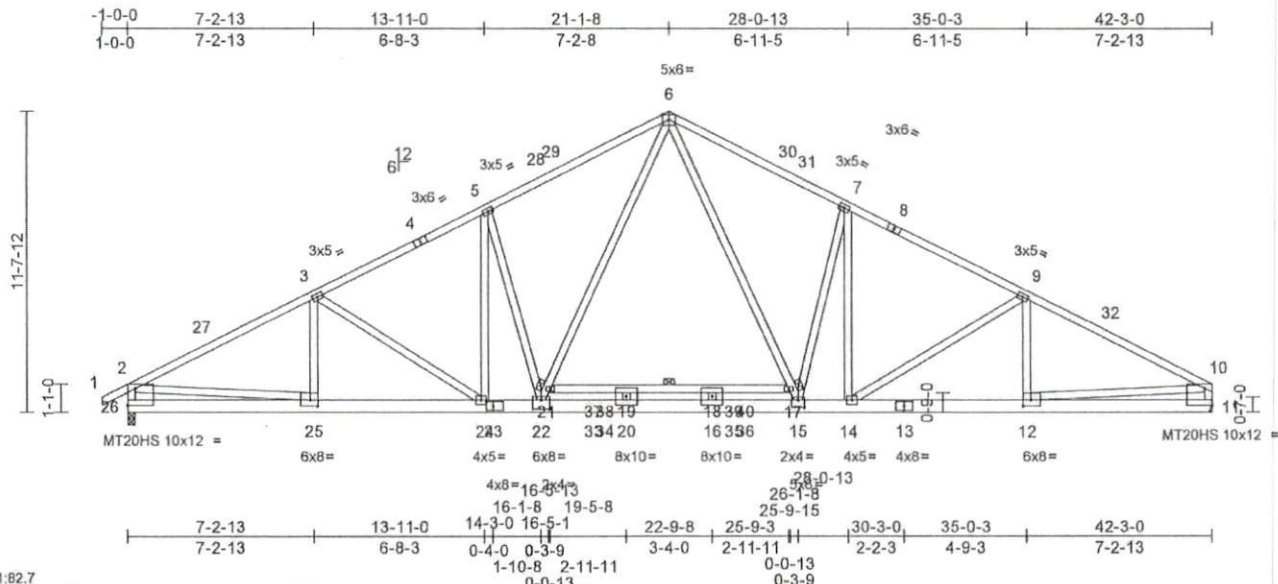

Scale = 1:82.7  
 Plate Offsets (X, Y): [11:Edge,0-7-13], [12:0-3-8,0-2-12], [15:0-3-0,0-3-8], [22:0-4-0,0-4-4], [23:0-3-4,0-2-0], [25:0-3-8,0-2-12], [26:Edge,0-7-13]

Loading	(psf)	Spacing	2-0-0	CSI	DEFL	in	(loc)	V/defl	L/d	PLATES	GRIP	
TCLL (roof)	20.0	Plate Grip DOL	1.15	TC	0.78	Vert(L.L)	-0.19	18-19	>999	240	MT20	244/190
Snow (Pf/Pg)	13.9/20.0	Lumber DOL	1.15	BC	0.42	Vert(CT)	-0.43	16-20	>999	180	MT20HS	187/143
TCDL	10.0	Rep Stress Incr	YES	WB	0.93	Horz(CT)	0.05	11	n/a	n/a		
BCLL	0.0*	Code	IRC2015/TPI2014	Matrix-MSH								
BCDL	10.0											

Weight: 322 lb FT = 20%

**LUMBER**  
 TOP CHORD 2x4 SP 2400F 2.0E  
 BOT CHORD 2x6 SP 2400F 2.0E \*Except\* 21-17:2x4 SP No.2  
 WEBS 2x4 SP No.3 \*Except\* 26-2:2x4 SP No.2, 22-6,15-6:2x4 SP 2400F 2.0E

**BRACING**  
 TOP CHORD Structural wood sheathing directly applied or 4-3-10 oc purlins, except end verticals.  
 BOT CHORD Rigid ceiling directly applied or 10-0-0 oc bracing. Except:  
 6-0-0 oc bracing: 17-21

**REACTIONS** (lb/size) 11=1616/ Mechanical, 26=1670/0-3-8  
 Max Horiz 26=142 (LC 12)  
 Max Grav 11=1873 (LC 2), 26=1942 (LC 2)

**FORCES** (lb) - Maximum Compression/Maximum Tension  
 TOP CHORD 1-2=0/37, 2-3=-3066/21, 3-5=-2833/32, 5-6=-2784/60, 6-7=-2787/69, 7-9=-2828/38, 9-10=-3074/38, 2-26=-1842/140, 10-11=-1774/89  
 BOT CHORD 25-26=-122/644, 24-25=0/2703, 22-24=0/2504, 20-22=0/2094, 16-20=0/2094, 15-16=0/2094, 14-15=0/2461, 12-14=0/2658, 11-12=-84/467, 19-21=-141/0, 18-19=-141/0, 17-18=-141/0  
 WEBS 2-25=0/2114, 10-12=0/2237, 3-25=-114/77, 3-24=-326/116, 5-24=-256/68, 7-14=-295/54, 9-14=-359/141, 9-12=-128/83, 21-22=0/1072, 6-21=0/1169, 5-22=-475/319, 6-17=0/1184, 15-17=0/1088, 7-15=-458/332, 19-20=-160/0, 16-18=-162/0

2) Wind: ASCE 7-10; Vult=130mph (3-second gust)  
 Vasd=103mph; TCCL=6.0psf; BCDL=6.0psf; h=25ft; Cat. II; Exp B; Enclosed; MWFRS (envelope) and C-C Exterior (2) 0-11-9 to 3-3-2, Interior (1) 3-3-2 to 21-1-8, Exterior (2) 21-1-8 to 25-4-3, Interior (1) 25-4-3 to 42-1-4 zone; cantilever left and right exposed; end vertical left and right exposed; C-C for members and forces & MWFRS for reactions shown; Lumber DOL=1.60 plate grip DOL=1.33

3) TCLL: ASCE 7-10; Pr=20.0 psf (roof live load: Lumber DOL=1.15 Plate DOL=1.15); Pg=20.0 psf (ground snow); Pf=13.9 psf (flat roof snow: Lumber DOL=1.15 Plate DOL=1.15); Category II; Exp B; Fully Exp.; Ct=1.10

4) Unbalanced snow loads have been considered for this design.

5) This truss has been designed for greater of min roof live load of 12.0 psf or 2.00 times flat roof load of 13.9 psf on overhangs non-concurrent with other live loads.

6) 200.0lb AC unit load placed on the bottom chord, 21-1-8 from left end, supported at two points, 5-0-0 apart.

7) All plates are MT20 plates unless otherwise indicated.

8) \* This truss has been designed for a live load of 20.0psf on the bottom chord in all areas where a rectangle 3-05-00 tall by 2-00-00 wide will fit between the bottom chord and any other members, with BCDL = 10.0psf.

9) Refer to girder(s) for truss to truss connections.

10) One H2.5A Simpson Strong-Tie connectors recommended to connect truss to bearing walls due to UPLIFT at J(s) 26. This connection is for uplift only and does not consider lateral forces.

11) This truss is designed in accordance with the 2015 International Residential Code sections R502.11.1 and R802.10.2 and referenced standard ANSI/TPI 1.

**NOTES**  
 1) Unbalanced roof live loads have been considered for this design.

LOAD CASE(S) Standard



Job 22020120-A	Truss A04	Truss Type Roof Special	Qty 1	Ply 1	Hunt Residence-Roof Job Reference (optional)	150710514
-------------------	--------------	----------------------------	----------	----------	---	-----------

Carter Components (Sanford), Sanford, NC - 27332,

Run: 8.53 S Dec 6 2021 Print: 8.530 S Dec 6 2021 MiTek Industries, Inc. Thu Mar 10 11:54:58  
ID:kW9qCKpcOqJrWe1gBwhb1Rzj82w-RIC?Psb70Hq3NSgPqnLbW3ulTXbGKwCDol7J4zJC?I

Page: 1

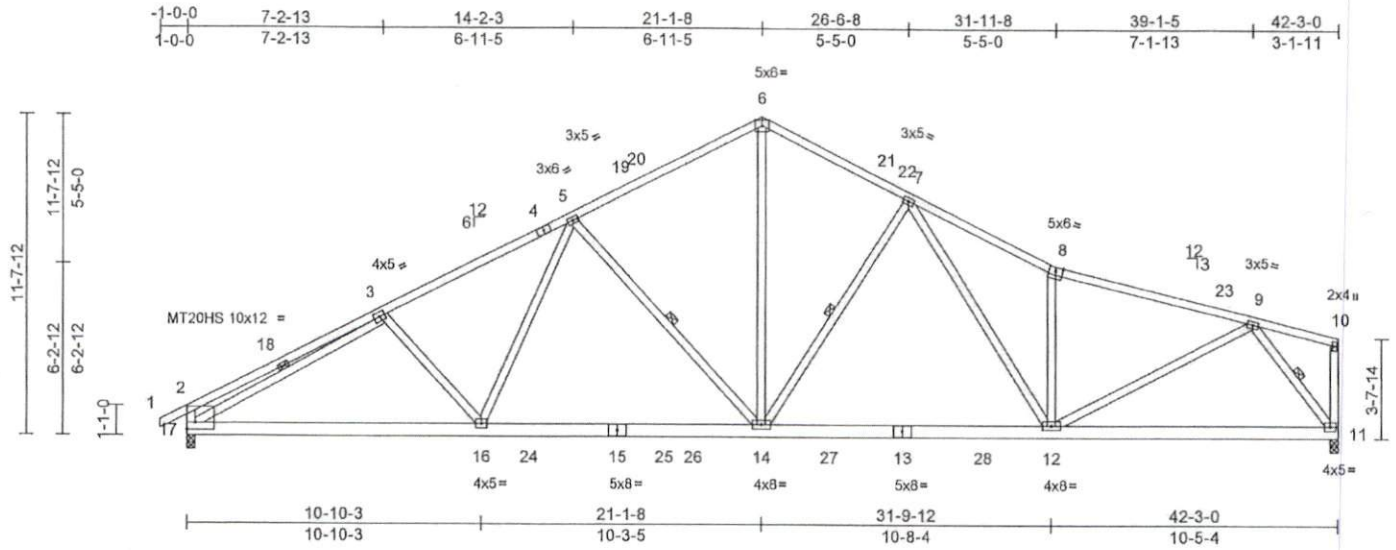

Scale = 1:77.8

Plate Offsets (X, Y): [2:Edge,0-3-0]

Loading	(psf)	Spacing	2-0-0	CSI	DEFL	in	(loc)	l/defl	L/d	PLATES	GRIP	
TCLL (roof)	20.0	Plate Grip DOL	1.15	TC	0.93	Vert(LL)	-0.21	12-14	>999	240	MT20	244/190
Snow (Pf/Pg)	13.9/20.0	Lumber DOL	1.15	BC	0.91	Vert(CT)	-0.42	12-14	>999	180	MT20HS	187/143
TCDL	10.0	Rep Stress Incr	YES	WB	0.87	Horz(CT)	0.09	11	n/a	n/a		
BCLL	0.0*	Code	IRC2015/TPI2014	Matrix-MSH								
BCDL	10.0											
											Weight: 294 lb	FT = 20%

**LUMBER**

TOP CHORD 2x4 SP No.2 \*Except\* 8-10:2x4 SP No.1  
 BOT CHORD 2x6 SP No.2  
 WEBS 2x4 SP No.3 \*Except\* 14-5,14-6:2x4 SP No.2

**BRACING**

TOP CHORD Structural wood sheathing directly applied, except end verticals.  
 BOT CHORD Rigid ceiling directly applied or 10-0-0 oc bracing.  
 WEBS 1 Row at midpt 5-14, 7-14, 3-17, 9-11

**REACTIONS**

(lb/size) 11=1520/0-3-8, 17=1574/0-3-8  
 Max Horiz 17=148 (LC 14)  
 Max Grav 11=1777 (LC 2), 17=1846 (LC 2)

**FORCES**

(lb) - Maximum Compression/Maximum Tension  
 TOP CHORD 1-2=0/37, 2-3=-717/176, 3-5=-2742/147, 5-6=-2108/154, 6-7=-2085/152, 7-8=-2777/176, 8-9=-2581/99, 9-10=-65/52, 2-17=-564/227, 10-11=-26/14  
 BOT CHORD 16-17=-185/2505, 14-16=-86/2253, 12-14=-46/2120, 11-12=-135/1251  
 WEBS 3-16=-208/179, 5-16=0/433, 5-14=-698/185, 6-14=0/1526, 7-14=-660/190, 7-12=-48/629, 8-12=-940/157, 9-12=0/1417, 3-17=-2291/0, 9-11=-2080/195

**NOTES**

- Unbalanced roof live loads have been considered for this design.
- Wind: ASCE 7-10; Vult=130mph (3-second gust) Vasd=103mph; TCCL=6.0psf; BCDL=6.0psf; h=25ft; Cat. II; Exp B; Enclosed; MWFRS (envelope) and C-C Exterior (2) 0-11-9 to 3-3-2, Interior (1) 3-3-2 to 21-1-8, Exterior (2) 21-1-8 to 25-4-3, Interior (1) 25-4-3 to 42-1-4 zone; cantilever left and right exposed; end vertical left and right exposed; C-C for members and forces & MWFRS for reactions shown; Lumber DOL=1.60 plate grip DOL=1.33

- TCLL: ASCE 7-10; Pr=20.0 psf (roof live load: Lumber DOL=1.15 Plate DOL=1.15); Pg=20.0 psf (ground snow); Pf=13.9 psf (flat roof snow: Lumber DOL=1.15 Plate DOL=1.15); Category II; Exp B; Fully Exp.; Ct=1.10
  - Unbalanced snow loads have been considered for this design.
  - This truss has been designed for greater of min roof live load of 12.0 psf or 2.00 times flat roof load of 13.9 psf on overhangs non-concurrent with other live loads.
  - 200.0lb AC unit load placed on the bottom chord, 21-1-8 from left end, supported at two points, 5-0-0 apart.
  - All plates are MT20 plates unless otherwise indicated.
  - \* This truss has been designed for a live load of 20.0psf on the bottom chord in all areas where a rectangle 3-06-00 tall by 2-00-00 wide will fit between the bottom chord and any other members, with BCDL = 10.0psf.
  - One H2.5A Simpson Strong-Tie connectors recommended to connect truss to bearing walls due to UPLIFT at jt(s) 17 and 11. This connection is for uplift only and does not consider lateral forces.
  - This truss is designed in accordance with the 2015 International Residential Code sections R502.11.1 and R802.10.2 and referenced standard ANSI/TPI 1.
- LOAD CASE(S) Standard



**WARNING** - Verify design parameters and READ NOTES ON THIS AND INCLUDED MITEK REFERENCE PAGE MII-7473 rev. 5/19/2020 BEFORE USE.  
 Design valid for use only with MiTek® connectors. This design is based only upon parameters shown, and is for an individual building component, not a truss system. Before use, the building designer must verify the applicability of design parameters and properly incorporate this design into the overall building design. Bracing indicated is to prevent buckling of individual truss web and/or chord members only. Additional temporary and permanent bracing is always required for stability and to prevent collapse with possible personal injury and property damage. For general guidance regarding the fabrication, storage, delivery, erection and bracing of trusses and truss systems, see ANSI/TPI1 Quality Criteria, DSB-89 and BCSI Building Component Safety Information available from Truss Plate Institute, 2670 Crain Highway, Suite 203 Waldorf, MD 20601

**ENGINEERING BY**  
**TRENCO**  
 A MiTek Affiliate  
 818 Soundside Road  
 Edenton, NC 27932

Job 22020120-A	Truss A03	Truss Type Roof Special	Qty 5	Ply 1	Hunt Residence-Roof Job Reference (optional)	150710515
-------------------	--------------	----------------------------	----------	----------	---	-----------

Carter Components (Sanford), Sanford, NC - 27332,

Run: 8.53 S Dec 6 2021 Print: 8.530 S Dec 6 2021 MiTek Industries, Inc. Thu Mar 10 11:54:58  
ID:n813oenMID27HLH4Ve7x0z62Y-RIC?PsB70Hq3NSgPqnl8w3ulTXbGKWCDof7J4zJC?l

Page: 1

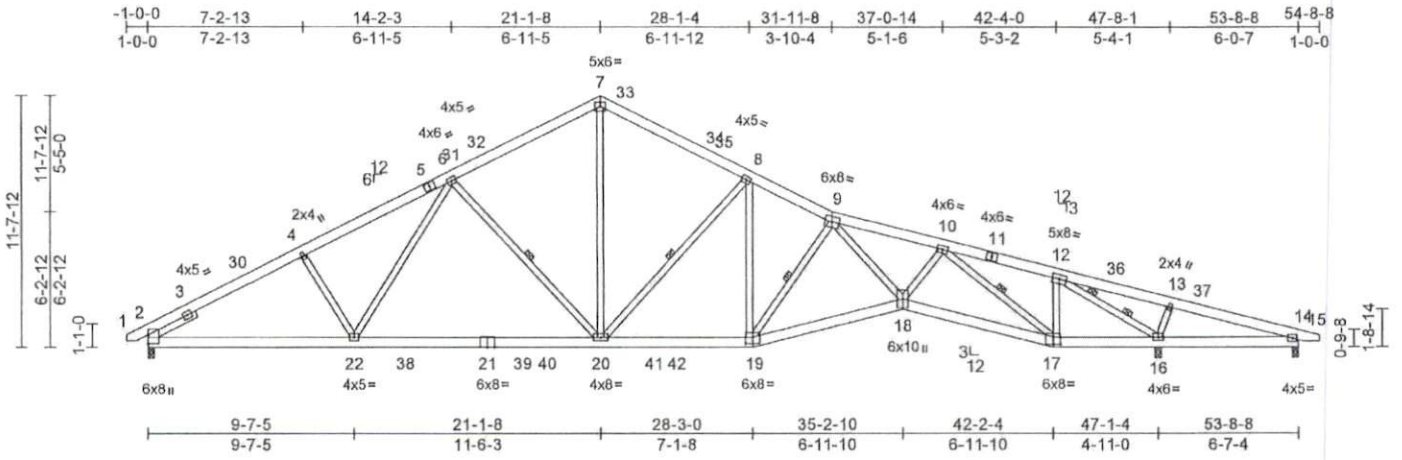

Scale = 1.99

Plate Offsets (X, Y): [17:0-4-0,0-4-0], [19:0-4-0,0-3-8]

Loading	(psf)	Spacing	2-0-0	CSI	DEFL	in	(loc)	l/defl	L/d	PLATES	GRIP	
TCLL (roof)	20.0	Plate Grip DOL	1.15	TC	0.80	Vert(LL)	-0.32	20-22	>999	240	MT20	244/190
Snow (P/Pg)	13.9/20.0	Lumber DOL	1.15	BC	0.97	Vert(CT)	-0.68	20-22	>827	180		
TCDL	10.0	Rep Stress Incr	YES	WB	0.95	Horz(CT)	0.20	16	n/a	n/a		
BCLL	0.0*	Code	IRC2015/TPI2014	Matrix-MSH								
BCDL	10.0											

Weight: 393 lb FT = 20%

LUMBER	
TOP CHORD	2x6 SP No.2
BOT CHORD	2x6 SP No.2 *Except* 17-14:2x6 SP 2400F 2.0E
WEBS	2x4 SP No.3 *Except* 20-7:2x4 SP No.2
SLIDER	Left 2x4 SP No.3 -- 2-6-0
BRACING	
TOP CHORD	Structural wood sheathing directly applied or 2-5-14 oc purlins.
BOT CHORD	Rigid ceiling directly applied or 2-2-0 oc bracing.
WEBS	1 Row at midpt 6-20, 8-20, 9-19, 10-17
WEBS	2 Rows at 1/3 pts 12-16
REACTIONS	(lb/size) 2=1645/0-3-8, 14=438/0-3-8, 16=2698/0-3-8
	Max Horiz 2=-115 (LC 13)
	Max Uplift 14=-517 (LC 3)
	Max Grav 2=1928 (LC 2), 14=-57 (LC 15), 16=3160 (LC 2)
FORCES	(lb) - Maximum Compression/Maximum Tension
TOP CHORD	1-2=0/26, 2-4=-3160/185, 4-6=-2986/209, 6-7=-2322/182, 7-8=-2316/174, 8-9=-2954/181, 9-10=-4420/191, 10-12=-1327/151, 12-13=-52/2366, 13-14=-56/2236, 14-15=0/12
BOT CHORD	2-22=-84/2720, 20-22=0/2432, 19-20=0/2619, 18-19=-25/3634, 17-18=-82/3709, 16-17=-21/1193, 14-16=-2100/73
WEBS	4-22=-219/184, 6-22=-19/462, 6-20=-699/207, 7-20=0/1646, 8-20=-955/193, 8-19=-5/644, 9-19=-1629/111, 9-18=-11/1183, 10-18=0/1203, 10-17=-3108/68, 12-17=0/1160, 12-16=-4162/160, 13-16=-510/141

- Unbalanced roof live loads have been considered for this design.
- Wind: ASCE 7-10; Vult=130mph (3-second gust) Vasd=103mph; TC DL=6.0psf; BCDL=6.0psf; h=25ft; Cat. II; Exp B; Enclosed; MWFRS (envelope) and C-C Exterior (2) -0-9-6 to 4-7-2, Interior (1) 4-7-2 to 21-1-8, Exterior (2) 21-1-8 to 26-5-15, Interior (1) 26-5-15 to 54-4-3 zone; cantilever left and right exposed; end vertical left and right exposed; C-C for members and forces & MWFRS for reactions shown; Lumber DOL=1.60 plate grip DOL=1.33
- TCLL: ASCE 7-10; Pr=20.0 psf (roof live load: Lumber DOL=1.15 Plate DOL=1.15); Pg=20.0 psf (ground snow); Pf=13.9 psf (flat roof snow: Lumber DOL=1.15 Plate DOL=1.15); Category II; Exp B; Fully Exp.; Ct=1.10
- Unbalanced snow loads have been considered for this design.
- This truss has been designed for greater of min roof live load of 12.0 psf or 2.00 times flat roof load of 13.9 psf on overhangs non-concurrent with other live loads.
- 200.0lb AC unit load placed on the bottom chord, 21-1-8 from left end, supported at two points, 5-0-0 apart.
- \* This truss has been designed for a live load of 20.0psf on the bottom chord in all areas where a rectangle 3-06-00 tall by 2-00-00 wide will fit between the bottom chord and any other members, with BCDL = 10.0psf.
- One H2.5A Simpson Strong-Tie connectors recommended to connect truss to bearing walls due to UPLIFT at jt(s) 2 and 16. This connection is for uplift only and does not consider lateral forces.
- H10A Simpson Strong-Tie connectors recommended to connect truss to bearing walls due to UPLIFT at jt(s) 14. This connection is for uplift only and does not consider lateral forces.
- This truss is designed in accordance with the 2015 International Residential Code sections R502.11.1 and R802.10.2 and referenced standard ANSI/TPI 1.

LOAD CASE(S) Standard



March 11, 2022

**WARNING** - Verify design parameters and READ NOTES ON THIS AND INCLUDED MITEK REFERENCE PAGE MI-7473 rev. 5/19/2020 BEFORE USE.  
Design valid for use only with MiTek® connectors. This design is based only upon parameters shown, and is for an individual building component, not a truss system. Before use, the building designer must verify the applicability of design parameters and properly incorporate this design into the overall building design. Bracing indicated is to prevent buckling of individual truss web and/or chord members only. Additional temporary and permanent bracing is always required for stability and to prevent collapse with possible personal injury and property damage. For general guidance regarding the fabrication, storage, delivery, erection and bracing of trusses and truss systems, see ANSITPH Quality Criteria, DSB-89 and BCSI Building Component Safety Information available from Truss Plate Institute, 2670 Crain Highway, Suite 203 Waldorf, MD 20681

ENGINEERING BY  
**TRENCO**  
A MiTek Affiliate  
818 Soundside Road  
Edenton, NC 27932

Job 22020120-A	Truss A02	Truss Type Roof Special	Qty 4	Ply 1	Hunt Residence-Roof Job Reference (optional)	150710516
-------------------	--------------	----------------------------	----------	----------	---	-----------

Carter Components (Sanford), Sanford, NC - 27332,

Run: 8.53 S Dec 6 2021 Print: 8.530 S Dec 6 2021 MiTek Industries, Inc. Thu Mar 10 11:54:57  
ID:NZMx9cdUajYQI9IPN5QKOzj637-RC?PsB70Hq3NSgPqL9w3uITXbGKwRCDoI7J4zJC7C

Page: 1

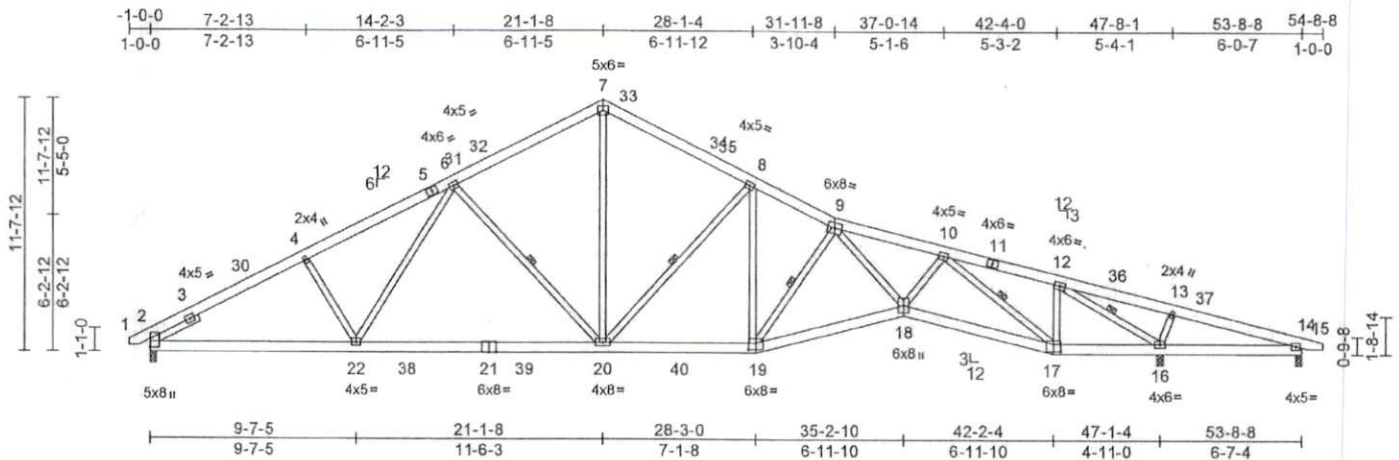

Scale = 1:99

Plate Offsets (X, Y): [17:0-4-0,0-4-0], [19:0-4-0,0-3-8]

Loading	(psf)	Spacing	2-0-0	CSI	DEFL	in	(loc)	l/defl	L/d	PLATES	GRIP	
TCLL (roof)	20.0	Plate Grip DOL	1.15	TC	0.76	Vert(LL)	-0.33	20-22	>999	240	MT20	244/190
Snow (Pf/Pg)	13.9/20.0	Lumber DOL	1.15	BC	0.85	Vert(CT)	-0.62	20-22	>906	180		
TCDL	10.0	Rep Stress Incr	YES	WB	0.97	Horz(CT)	0.19	16	n/a	n/a		
BCLL	0.0*	Code	IRC2015/TPI2014	Matrix-MSH								
BCDL	10.0											
											Weight: 393 lb	FT = 20%

**LUMBER**

TOP CHORD 2x6 SP No.2  
BOT CHORD 2x6 SP No.2  
WEBS 2x4 SP No.3 \*Except\* 20-7:2x4 SP No.2  
SLIDER Left 2x4 SP No.3 -- 2-6-0

**BRACING**

TOP CHORD Structural wood sheathing directly applied or 2-11-6 oc purlins.  
BOT CHORD Rigid ceiling directly applied or 10-0-0 oc bracing, Except: 4-10-3 oc bracing: 14-16.

WEBS 1 Row at midpt 6-20, 8-20, 9-19, 10-17, 12-16  
REACTIONS (lb/size) 2=1548/0-3-8, 14=347/0-3-8, 16=2504/0-3-8  
Max Horiz 2=-115 (LC 13)  
Max Uplift 14=-419 (LC 3), 16=-14 (LC 16)  
Max Grav 2=1832 (LC 2), 14=-5 (LC 15), 16=2958 (LC 2)

**FORCES**

(lb) - Maximum Compression/Maximum Tension  
TOP CHORD 1-2=0/26, 2-4=-2971/389, 4-6=-2796/414, 6-7=-2128/393, 7-8=-2122/385, 8-9=-2762/405, 9-10=-4238/459, 10-12=-1369/208, 12-13=-188/2093, 13-14=-189/1962, 14-15=0/12  
BOT CHORD 2-22=-233/2556, 20-22=-165/2258, 19-20=-162/2447, 18-19=-271/3438, 17-18=-293/3588, 16-17=-72/1239, 14-16=-1833/203  
WEBS 4-22=-235/167, 6-22=-12/468, 6-20=-698/207, 7-20=-166/1472, 8-20=-955/210, 8-19=-24/642, 9-19=-1596/184, 9-18=-44/1203, 10-18=-13/1095, 10-17=-2897/268, 12-17=-32/1077, 12-16=-3900/381, 13-16=-521/153

**NOTES**

- 1) Unbalanced roof live loads have been considered for this design.
- 2) Wind: ASCE 7-10; Vult=130mph (3-second gust) Vasd=103mph; TCDL=6.0psf; BCDL=6.0psf; h=25ft; Cat. II; Exp B; Enclosed; MWFRS (envelope) and C-C Exterior (2) -0-9-6 to 4-7-2, Interior (1) 4-7-2 to 21-1-8, Exterior (2) 21-1-8 to 26-5-15, Interior (1) 26-5-15 to 54-4-3 zone; cantilever left and right exposed; end vertical left and right exposed; C-C for members and forces & MWFRS for reactions shown; Lumber DOL=1.60 plate grip DOL=1.33
- 3) TCLL: ASCE 7-10; Pr=20.0 psf (roof live load; Lumber DOL=1.15 Plate DOL=1.15); Pg=20.0 psf (ground snow); Pf=13.9 psf (flat roof snow; Lumber DOL=1.15 Plate DOL=1.15); Category II; Exp B; Fully Exp.; Ct=1.10
- 4) Unbalanced snow loads have been considered for this design.
- 5) This truss has been designed for greater of min roof live load of 12.0 psf or 2.00 times flat roof load of 13.9 psf on overhangs non-concurrent with other live loads.
- 6) \* This truss has been designed for a live load of 20.0psf on the bottom chord in all areas where a rectangle 3-06-00 tall by 2-00-00 wide will fit between the bottom chord and any other members, with BCDL = 10.0psf.
- 7) One H2.5A Simpson Strong-Tie connectors recommended to connect truss to bearing walls due to UPLIFT at jt(s) 2 and 16. This connection is for uplift only and does not consider lateral forces.
- 8) H10A Simpson Strong-Tie connectors recommended to connect truss to bearing walls due to UPLIFT at jt(s) 14. This connection is for uplift only and does not consider lateral forces.
- 9) This truss is designed in accordance with the 2015 International Residential Code sections R502.11.1 and R802.10.2 and referenced standard ANSI/TPI 1.

LOAD CASE(S) Standard



**WARNING** - Verify design parameters and READ NOTES ON THIS AND INCLUDED MITEK REFERENCE PAGE MI-7473 rev. 5/19/2020 BEFORE USE.  
Design valid for use only with MiTek connectors. This design is based only upon parameters shown, and is for an individual building component, not a truss system. Before use, the building designer must verify the applicability of design parameters and properly incorporate this design into the overall building design. Bracing indicated is to prevent buckling of individual truss web and/or chord members only. Additional temporary and permanent bracing is always required for stability and to prevent collapse with possible personal injury and property damage. For general guidance regarding the fabrication, storage, delivery, erection and bracing of trusses and truss systems, see ANSITPH Quality Criteria, DSB-89 and BCSI Building Component Safety Information available from Truss Plate Institute, 2670 Crain Highway, Suite 203 Waldorf, MD 20601

ENGINEERING BY  
**TRENCO**  
A MiTek Affiliate  
818 Soundside Road  
Edenton, NC 27932

## Symbols

### PLATE LOCATION AND ORIENTATION

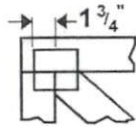

Center plate on joint unless x, y offsets are indicated. Dimensions are in ft-in-sixteenths. Apply plates to both sides of truss and fully embed teeth.

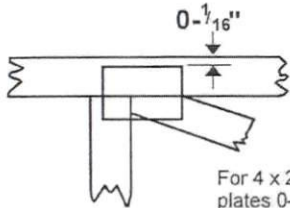

For 4 x 2 orientation, locate plates 0- 1/16" from outside edge of truss.



This symbol indicates the required direction of slots in connector plates.

\* Plate location details available in MiTek 20/20 software or upon request.

### PLATE SIZE

4 x 4

The first dimension is the plate width measured perpendicular to slots. Second dimension is the length parallel to slots.

### LATERAL BRACING LOCATION

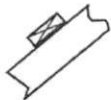

Indicated by symbol shown and/or by text in the bracing section of the output. Use T or I bracing if indicated.

### BEARING

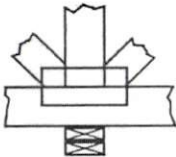

Indicates location where bearings (supports) occur. Icons vary but reaction section indicates joint number where bearings occur. Min size shown is for crushing only.

### Industry Standards:

- ANSI/TPI1: National Design Specification for Metal Plate Connected Wood Truss Construction.  
 DSB-89: Design Standard for Bracing.  
 BCSI: Building Component Safety Information, Guide to Good Practice for Handling, Installing & Bracing of Metal Plate Connected Wood Trusses.

## Numbering System

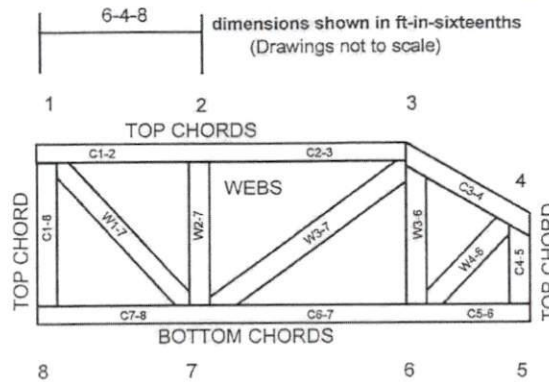

JOINTS ARE GENERALLY NUMBERED/LETTERED CLOCKWISE AROUND THE TRUSS STARTING AT THE JOINT FARTHEST TO THE LEFT.

CHORDS AND WEBS ARE IDENTIFIED BY END JOINT NUMBERS/LETTERS.

### PRODUCT CODE APPROVALS

ICC-ES Reports:

ESR-1311, ESR-1352, ESR1988  
 ER-3907, ESR-2362, ESR-1397, ESR-3282

Trusses are designed for wind loads in the plane of the truss unless otherwise shown.

Lumber design values are in accordance with ANSI/TPI 1 section 6.3 These truss designs rely on lumber values established by others.

© 2012 MiTek® All Rights Reserved



MiTek Engineering Reference Sheet: MII-7473 rev. 5/19/2020



## General Safety Notes

### Failure to Follow Could Cause Property Damage or Personal Injury

1. Additional stability bracing for truss system, e.g. diagonal or X-bracing, is always required. See BCSI.
2. Truss bracing must be designed by an engineer. For wide truss spacing, individual lateral braces themselves may require bracing, or alternative Tor I bracing should be considered.
3. Never exceed the design loading shown and never stack materials on inadequately braced trusses.
4. Provide copies of this truss design to the building designer, erection supervisor, property owner and all other interested parties.
5. Cut members to bear tightly against each other.
6. Place plates on each face of truss at each joint and embed fully. Knots and wane at joint locations are regulated by ANSI/TPI 1.
7. Design assumes trusses will be suitably protected from the environment in accord with ANSI/TPI 1.
8. Unless otherwise noted, moisture content of lumber shall not exceed 19% at time of fabrication.
9. Unless expressly noted, this design is not applicable for use with fire retardant, preservative treated, or green lumber.
10. Camber is a non-structural consideration and is the responsibility of truss fabricator. General practice is to camber for dead load deflection.
11. Plate type, size, orientation and location dimensions indicated are minimum plating requirements.
12. Lumber used shall be of the species and size, and in all respects, equal to or better than that specified.
13. Top chords must be sheathed or purlins provided at spacing indicated on design.
14. Bottom chords require lateral bracing at 10 ft. spacing, or less, if no ceiling is installed, unless otherwise noted.
15. Connections not shown are the responsibility of others.
16. Do not cut or alter truss member or plate without prior approval of an engineer.
17. Install and load vertically unless indicated otherwise.
18. Use of green or treated lumber may pose unacceptable environmental, health or performance risks. Consult with project engineer before use.
19. Review all portions of this design (front, back, words and pictures) before use. Reviewing pictures alone is not sufficient.
20. Design assumes manufacture in accordance with ANSI/TPI 1 Quality Criteria.
21. The design does not take into account any dynamic or other loads other than those expressly stated.



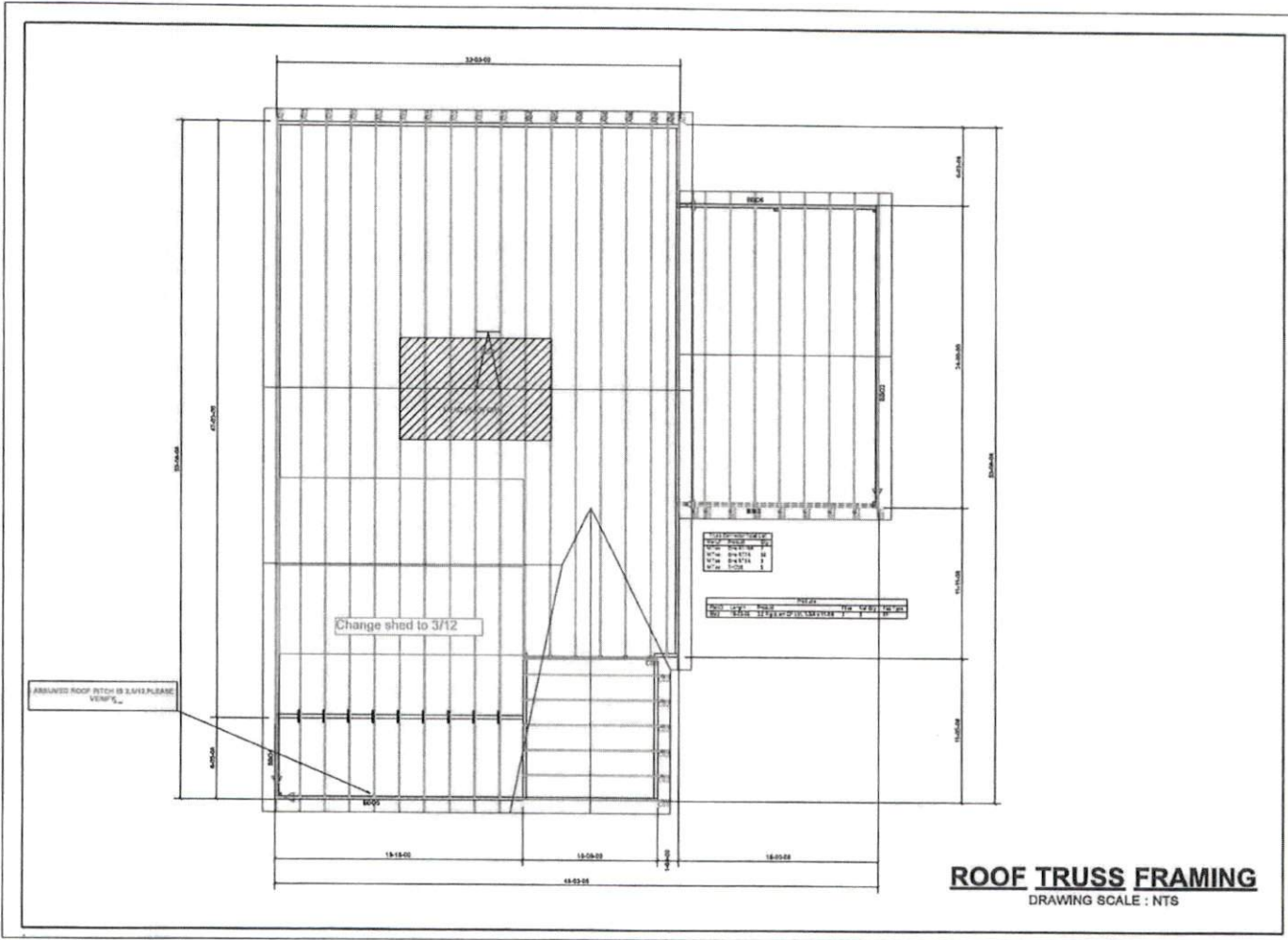

**ROOF TRUSS FRAMING**  
DRAWING SCALE : NTS



Custom Contracting Corp  
 Hunt Residence - Custom plan  
 ROOF TRUSS PLACEMENT PLAN

REVISIONS	DATE	BY
	05-21-23	JK

PROJECT NUMBER  
 22020120  
 SHEET NUMBER  
**1 / 1**