

# Harnett County Department of Public Health

## Improvement Permit

A building permit cannot be issued with only an Improvement Permit

ISSUED TO: Davidson Homes, LLC PROPERTY LOCATION: 75 Royal Ella Ct. (Christian Light Rd. - SR  
 SUBDIVISION Prince Place LOT # 11

NEW  REPAIR  EXPANSION  Site Improvements required prior to Construction Authorization Issuance:  
 Type of Structure: 50.3x70.4(4bed/3.5ba)  
 Proposed Wastewater System Type: 25% Reduction Sys.  
 Projected Daily Flow: 480 GPD  
 Number of bedrooms: 4 Number of Occupants: 8 max  
 Basement  Yes  No  
 Pump Required:  Yes  No  May be required based on final location and elevations of facilities  
 Type of Water Supply:  Community  Public  Well Distance from well NA feet Permit valid for:  Five years  
 Permit conditions: \_\_\_\_\_  No expiration

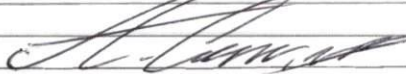
Authorized State Agent:  Date: 11/24/2021 SEE ATTACHED SITE SKETCH  
 The issuance of this permit by the Health Department in no way guarantees the issuance of other permits. The permit holder is responsible for checking with appropriate governing bodies in meeting their requirements. This site is subject to revocation if the site plan, plat, or the intended use changes. The Improvement Permit shall not be affected by a change in ownership of the site. This permit is subject to compliance with the provisions of the Laws and Rules for Sewage Treatment and Disposal and to conditions of this permit.

## Construction Authorization

(Required for Building Permit)

The construction and installation requirements of Rules .1950, .1952, .1954, .1955, .1956, .1957, .1958, and .1959 are incorporated by references into this permit and shall be met. Systems shall be installed in accordance with the attached system layout.

ISSUED TO: Davidson Homes, LLC PROPERTY LOCATION: 75 Royal Ella Ct. (Christian Light Rd. - S  
 SUBDIVISION Davidson Homes, LLC LOT # 11

Facility Type: 50.3x70.4(4bed/3.5ba)  New  Expansion  Repair  
 Basement?  Yes  No Basement Fixtures?  Yes  No  
 Type of Wastewater System\*\* Pump to 25% Reduction System (Initial) Wastewater Flow: 480 GPD  
 (See note below, if applicable   
Pump to 50% Red. PPBPS Sys. (Repair)

<u>Installation Requirements/Conditions</u>	Number of trenches <u>5</u>	
Septic Tank Size <u>1000</u> gallons	Exact length of each trench <u>400 (total)</u> feet	Trench Spacing: <u>9</u> Feet on Center
Pump Tank Size <u>1000</u> gallons	Trenches shall be installed on contour at a	Soil Cover: <u>12</u> inches
	Maximum Trench Depth of: <u>24</u> inches	(Maximum soil cover shall not exceed
	(Trench bottoms shall be level to +/-1/4"	36" above the trench bottom)
	in all directions)	
Pump Requirements: _____ ft. TDH vs. _____ GPM		<u>NA</u> inches below pipe
		Aggregate Depth: <u>NA</u> inches above pipe
Conditions: <u>Proposal by Mitchell Eviro. ; Pump to D-Box Equal Distribution</u>		<u>NA</u> inches total

**WATER LINES (INCLUDING IRRIGATION) MUST BE 10FT. FROM ANY PART OF SEPTIC SYSTEM OR REPAIR AREA.**  
**NO UTILITIES ALLOWED IN INITIAL OR REPAIR DRAIN FIELD AREA.**

\*\*If applicable: I understand the system type specified is different from the type specified on the application. I accept the specifications of this permit.

Owner/Legal Representative Signature: \_\_\_\_\_ Date: \_\_\_\_\_

This Construction Authorization is subject to revocation if the site plan, plat, or the intended use changes. The Construction Authorization shall not be transferred when there is a change in ownership of the site. This Construction Authorization is subject to compliance with the provisions of the Laws and Rules for Sewage Treatment and Disposal and to the conditions of this permit. SEE ATTACHED SITE SKETCH

Authorized State Agent:  Date: 11/24/2021  
ANDREW COLLINS Construction Authorization Expiration Date: 11/24/2026



**Mitchell Environmental, P.A.**

**SEPTIC SYSTEM DESIGN**

**for**

**PRINCE PLACE SUBDIVISION- LOT 11**

**Fuquay-Varina, Harnett County, North Carolina**

**Submitted to:**

Harnett County Health Department  
307 Cornelius Harnett Blvd.  
Lillington, NC 27546

**Prepared for:**

Davidson Homes, LLC  
336 James Record Road  
Huntsville, Alabama 35824

**Prepared by:**

Scott Mitchell, PE, LSS  
Adam Aycocock, EI

**DATE: October 20, 2021**  
**PROJECT NO.: 4321**

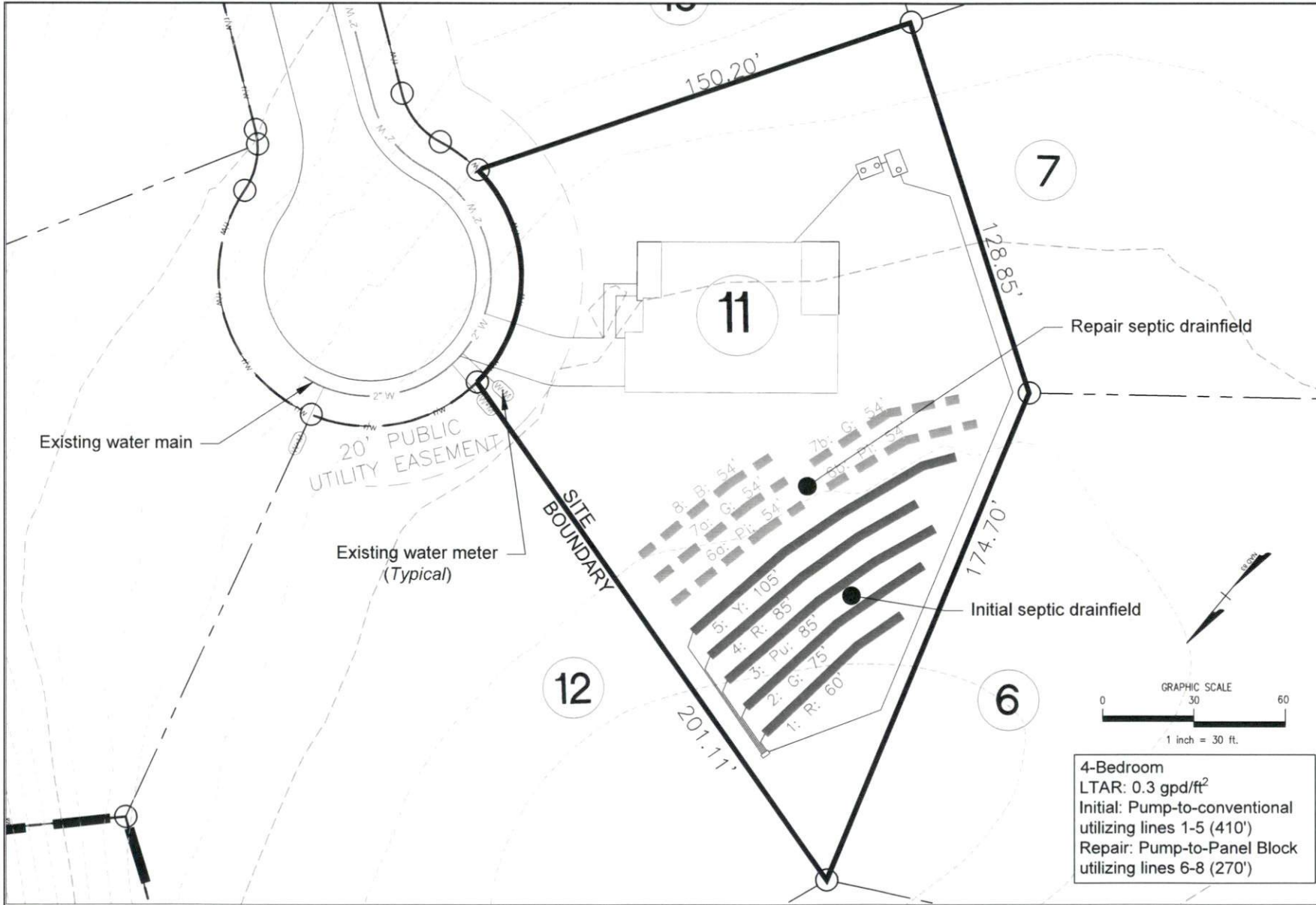

4-Bedroom  
 LTAR: 0.3 gpd/ft<sup>2</sup>  
 Initial: Pump-to-conventional  
 utilizing lines 1-5 (410')  
 Repair: Pump-to-Panel Block  
 utilizing lines 6-8 (270')

<b>REVISION NO.</b> Original: Submitted		<b>DATE</b> October 19, 2021	<b>SHEET NUMBER</b>  <b>1 of 7</b>
Revision 1			
Revision 2			
Revision 3			
Master Set			Prince Place Lot 11 Overall: Septic
<b>PREPARED FOR:</b> Division Homes 330 Jenna Record Road Huntsville, AL 35824		<b>DATE:</b> October 19, 2021	
<b>ENGINEER AND SOIL SCIENTIST CONTACT:</b> SCOTT MITCHELL, P.E., L.S.		<b>GRAPH BY:</b> ADAM WOOD, D.	
<b>MITCHELL ENVIRONMENTAL, PA</b> <b>C-2911</b> <b>1501 LAKESTONE VILLAGE LANE</b> <b>SUITE 205</b> <b>FUQUAY VARINA, NC 27526</b>			



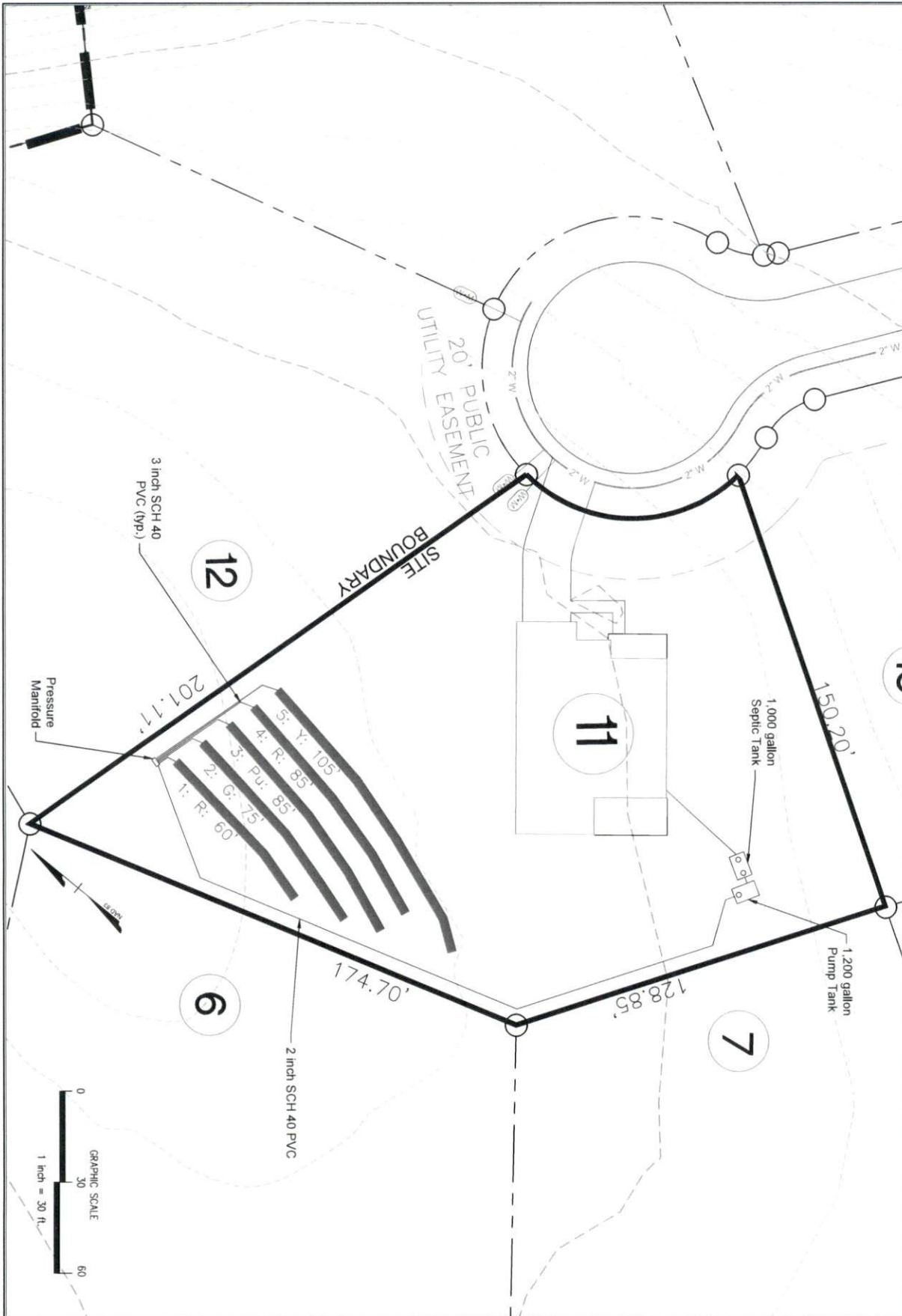

**MITCHELL ENVIRONMENTAL, PA**  
 C-2911  
 1501 LAKESTONE VILLAGE LANE  
 SUITE 205  
 FUQUAY VARINA, NC 27526

PREPARED FOR: Davidson Homes  
 336 James Record Road  
 Huntsville, AL 35824

DATE: October 19, 2021

ENGINEER AND SOIL SCIENTIST CONTACT:  
 SCOTT MITCHELL, PE, LSS

DRAWN BY:  
 ADAM AYCOCK, EI

REVISION NO.	DATE
Original Submittal	October 19, 2021
Revision 1	-----
Revision 2	-----
Revision 3	-----
Master Set	-----

**SHEET NUMBER**

2 of 7

Prince Place  
 Lot 11  
 Initial Nitrification Field

**PRESSURE MANIFOLD DESIGN**

Name: Davidson Homes P.I.N. #: 0633-76-5823 D #: N/A  
 Address: Royal Ella Court Subdiv: Prince Place Lot#: 11  
 # of BDR: 4 Daily Flow: 480 gal/day L.T.A.R.: 0.300 gal/day/sq.ft  
 Septic Tank: 1000 gals (min.) Pump Tank: 1200 gals (min.) Sq. Foot: 1230 Stone Depth: N/A  
 Number of Taps: 5 Length of Trenches: Varies ft(See Tap Chart for Details)  
 Depth of Trenches: see Harnett County Permit Manifold Length: 48 in  
 Manifold Diameter: 4 in sch 80pvc (minimum) Tap Configuration: 6 in spacing 1 side(s) of manifold  
 Supply Line: length: 240 ft Diameter: 2 in sch 40pvc  
 Friction Loss + Fitting Loss: 9.50 ft(supply line length + 70' for fittings in pump tank)  
 Design Head: 2.0 ft Elevation Head: 7.78 ft  
 Vent Hole Size: 3/16 in Orifice Coefficient of Discharge: 0.60  
 Orifice Coefficient of Contraction: 0.62 Orifice Coefficient of Velocity: 0.97  
 Maximum Head Supplied by Selected Pump(s) at Total Design Flowrate: 27 ft  
 Orifice / Vent Hole Flowrate: 2.15 gpm Head Loss at Orifice / Vent Hole: 1.71 ft  
 Total Head: 20.99 ft Pump to Deliver: 39.06 gals/min at 20.99 ft head  
 Dosing Volume: 175.89 gals.  
 Drawdown: 175.89 gals divided by 19 gals/in = 9.26 inches

SJE Rhombus Installer Friendly Series simplex control panel, or equivalent, required  
 A septic tank filter, or equal is required.  
 Possible pumps: Hydromatic: Goulds: Myers:  
 Zoeller: 153 Other:

**TAP CHART**

line	color	rod read	Elevation	length	hole size	flow/tap	gal/day	trench area	LINE LTAR
1	Red	3.22	100.88	60	1/2in SCH 80	5.48	71.27	180	0.3959
2	Green	3.44	100.66	75	1/2in SCH 40	7.11	92.46	225	0.4109
3	Purple	3.58	100.52	85	1/2in SCH 40	7.11	92.46	255	0.3626
4	Red	3.76	100.34	85	1/2in SCH 40	7.11	92.46	255	0.3626
5	Yellow	3.89	100.21	105	3/4in SCH 80	10.10	131.35	315	0.4170
		<b>total</b>	<b>feet =</b>	<b>410</b>	<b>gal/min =</b>	<b>36.9</b>	<b>LTAR =</b>	<b>0.3000</b>	
% of Pipe Vol.		<u>66</u>		<b>Des. Flow</b>	480.00		<b>(ltar + 5%)</b>	0.3150	
Dose Volume		175.89		<b>Pump Run=</b>	13.00		<b>(ltar W/ INOV)</b>	0.4000	
Dose Pump Time		4.77		<b>Tank Gal/IN</b>	19		<b>(ltar + 5%)</b>	0.4200	
Drawdown in Inches		9.26		<b>Elev. Head</b>	7.78				
Supply Line Length		240							
Comments:									

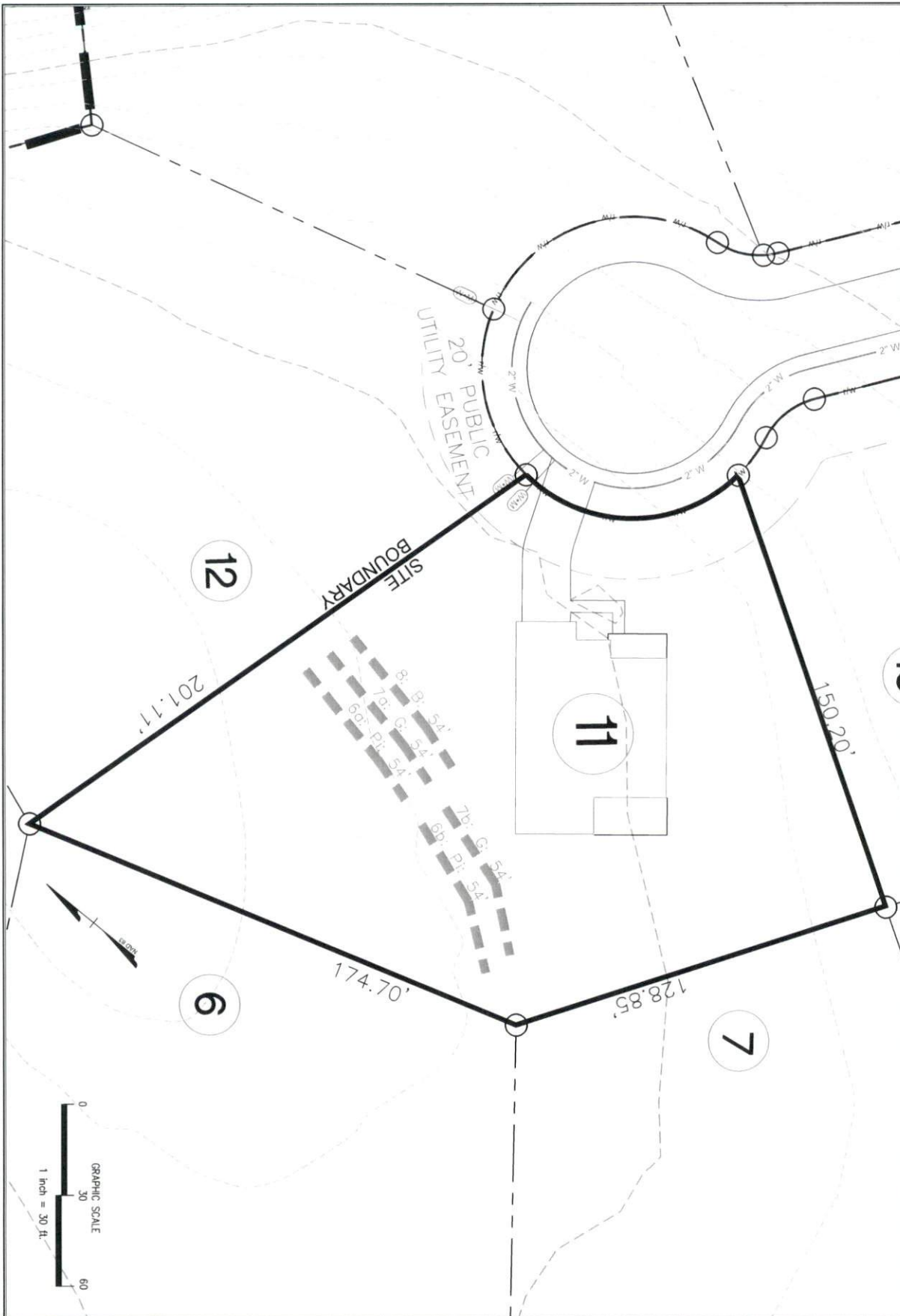

**MITCHELL ENVIRONMENTAL, PA**  
 C-2911  
 1501 LAKESTONE VILLAGE LANE  
 SUITE 205  
 FUQUAY VARINA, NC 27526

PREPARED FOR: Davidson Homes  
 336 James Record Road  
 Huntsville, AL 35824  
 DATE: October 19, 2021  
 ENGINEER AND SOIL SCIENTIST CONTACT:  
 SCOTT MITCHELL, PE, LSS  
 DRAWN BY:  
 ADAM AYCOCK, EI

REVISION NO.	DATE
Original Submittal	October 19, 2021
Revision 1	-----
Revision 2	-----
Revision 3	-----
Master Set	-----

**SHEET NUMBER**  
 3 of 7  
 Prince Place  
 Lot 11  
 Repair Nitrification Field

Repair System

**PRESSURE MANIFOLD DESIGN**

Name: Davidson Homes P.I.N. #: 0633-76-5823 D #: N/A  
 Address: Royal Ella Court Subdiv: Prince Place Lot#: 11  
 # of BDR: 4 Daily Flow: 480 gal/day L.T.A.R.: 0.300 gal/day/sq.ft  
 Septic Tank: 1000 gals (min.) Pump Tank: 1200 gals (min.) Sq. Foot: 810 Stone Depth: N/A  
 Number of Taps: 5 Length of Trenches: 54 ft(See Tap Chart for Details) (Panel Block)  
 Depth of Trenches: see Harnett County Permit Manifold Length: 48 in  
 Manifold Diameter: 4 in sch 80pvc (minimum) Tap Configuration: 6 in spacing 1 side(s) of manifold  
 Supply Line: length: 140 ft Diameter: 2 in sch 40pvc  
 Friction Loss + Fitting Loss: 3.71 ft(supply line length + 70' for fittings in pump tank)  
 Design Head: 2.0 ft Elevation Head: 7.44 ft  
 Vent Hole Size: 3/16 in Orifice Coefficient of Discharge: 0.60  
 Orifice Coefficient of Contraction: 0.62 Orifice Coefficient of Velocity: 0.97  
 Maximum Head Supplied by Selected Pump(s) at Total Design Flowrate: 31 ft  
 Orifice / Vent Hole Flowrate: 2.31 gpm Head Loss at Orifice / Vent Hole: 1.97 ft  
 Total Head: 15.12 ft Pump to Deliver: 29.71 gals/min at 15.12 ft head  
 Dosing Volume: 115.83 gals.  
 Drawdown: 115.83 gals divided by 19 gals/in = 6.10 inches

SJE Rhombus Installer Friendly Series simplex control panel, or equivalent, required  
 A septic tank filter, or equal is required.  
 Possible pumps: Hydromatic: Goulds: Myers:  
 Zoeller: 153 Other:

**TAP CHART**

Bench Mark	4.1	is = 100.00	set at	Top EIR 6/7 rear corner			Design Head:	2.0		
Pump tank elev.	5.5	98.60		Pump elev.	93.60	Manifold elev.	101.04			
line	color	rod read	Elevation	length	hole size	flow/tap	gal/day	trench area	LINE	LTAR
6a	Pink	4.06	100.04	54	1/2in SCH 80	5.48	96.00	162		0.5926
6b	Pink	4.06	100.04	54	1/2in SCH 80	5.48	96.00	162		0.5926
7a	Green	4.15	99.95	54	1/2in SCH 80	5.48	96.00	162		0.5926
7b	Green	4.15	99.95	54	1/2in SCH 80	5.48	96.00	162		0.5926
8	Blue	4.59	99.51	54	1/2in SCH 80	5.48	96.00	162		0.5926
		<b>total</b>	<b>feet =</b>	<b>270</b>	<b>gal/min =</b>	<b>27.4</b>	<b>LTAR =</b>		<b>0.3000</b>	
% of Pipe Vol.	<u>66</u>		<b>Des. Flow</b>		480.00	<b>(Itar + 5%)</b>		0.3150		
Dose Volume	115.83		<b>Pump Run=</b>		17.52	<b>(Itar W/ INOV)</b>		0.6000		
Dose Pump Time	4.23		<b>Tank Gal/IN</b>		19	<b>(Itar + 5%)</b>		0.6300		
Drawdown in Inches	6.10		<b>Elev. Head</b>		7.44					
Supply Line Length	140									

Comments:



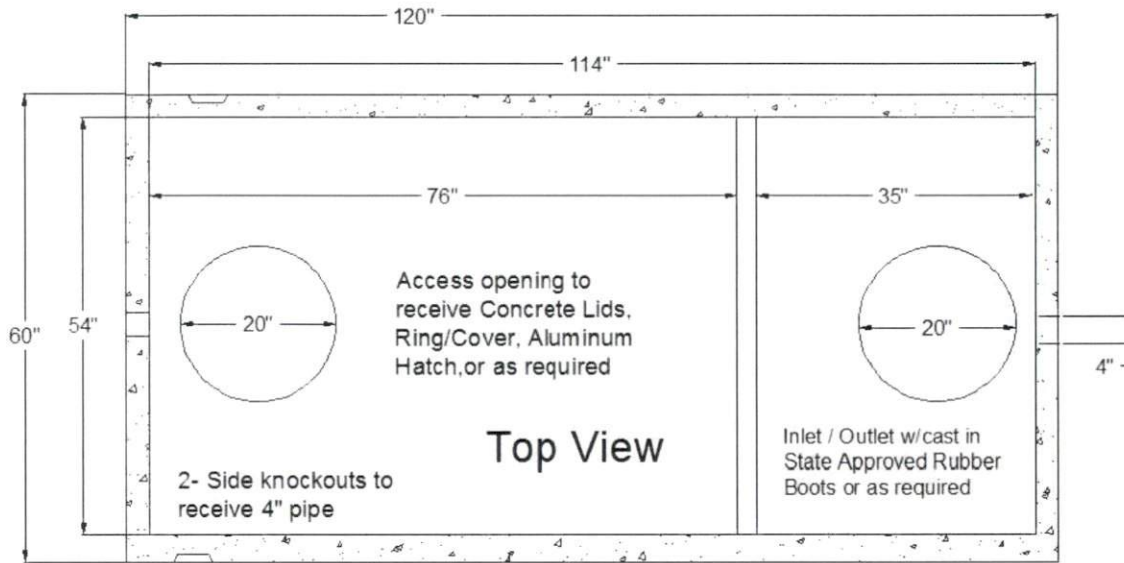

## STB - 345 - Top Seam

Approval Date: 12 - 09 - 99

Liquid Capacity 1007 Gallons

Non Traffic Rated

Reinforcing Schedule: # 3 Grade 60 Rebar

4500 PSI Concrete w/ State Approved Structural Fiber

Est. Weight: 8,200 lbs.

Manufactured By:

**GARNERS**  
Septic Tanks, Inc.

Eddie Garner, President  
919-718-5181

121 Stanton Hill Road  
Carthage, NC 28327 Fax 919-775-2229  
Eddie@garnersseptic tanks.com

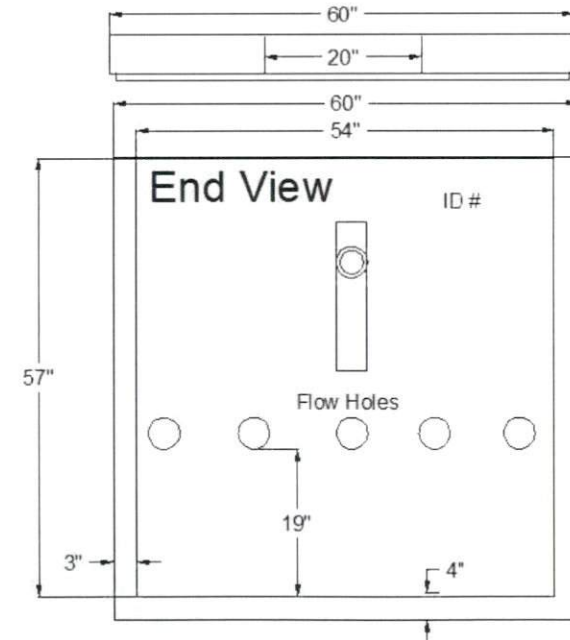
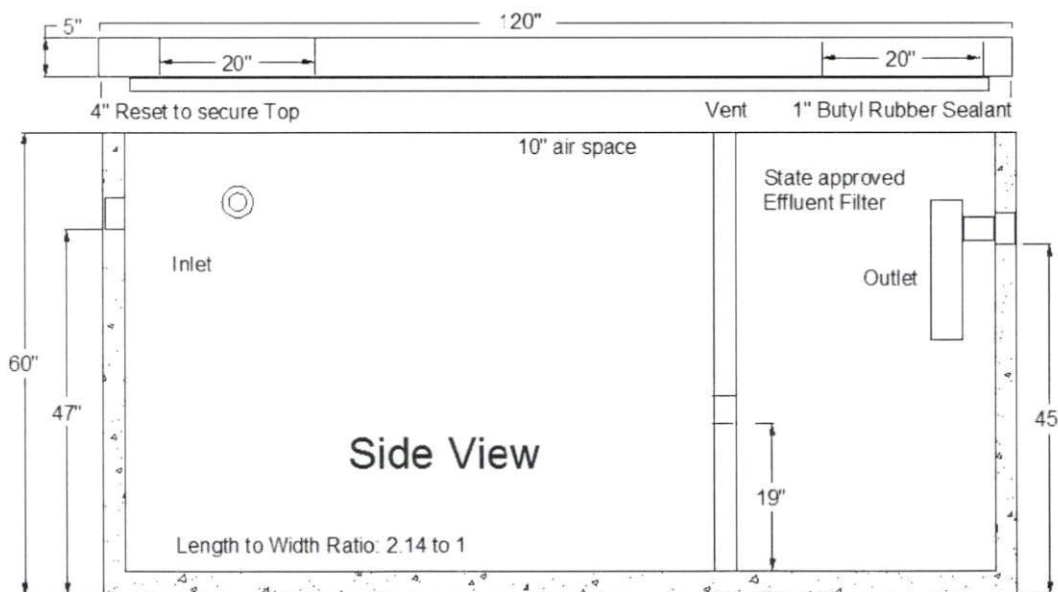



**PL-68 Filter and Tee**

PL-68 is much more than just an effluent filter. The housing can also be used as an inlet baffle (tee) or an outlet baffle. The housing is designed to accept Polylok's snap in gas deflector to deflect gas bubbles away from the tee and to keep the solids in the tank.

**Features:**

- Offers 68 linear feet of 1/16" filter slots, which significantly extends time between cleaning.
- Accepts 3/4" PVC handle.
- Locks in any 360° position when used with PL-68 Tee.
- PL-68 Housing can be used as an inlet or outlet tee.
- Gasket prevents bypass.

**PL-68 Installation:**

Ideal for residential waste flows up to 800 gallons per day (GPD). Easily installs in any new or existing 4" outlet tee.

1. Locate the outlet of the septic tank.
2. Remove the tank cover and pump tank if necessary.
3. Glue the filter housing to the outlet pipe, or use a Polylok Extend & Lok if not enough pipe exists.
4. Insert the PL-68 filter into tee.
5. Replace and secure the septic tank cover.

**PL-68 Maintenance:**

The PL-68 Effluent Filter will operate efficiently for several years under normal conditions before requiring cleaning. It is recommended that the filter be cleaned every time the tank is pumped, or at least every three years.

1. Do not use plumbing when filter is removed.
2. Pull PL-68 out of the tee.
3. Hose off filter over the septic tank. Make sure all solids fall back into septic tank.
4. Insert filter back into tee/housing.

**Related Products:**

PL-68 Filter Concrete Baffle  
 Extend & Lok™



Extend & Lok™  
 Easily installs into existing tanks.



Spacer Bushing  
 4" SCHD 40 to SDR 35



Spacer Bushing  
 4" SCHD 40 to 110mm Pipe



2" Extender

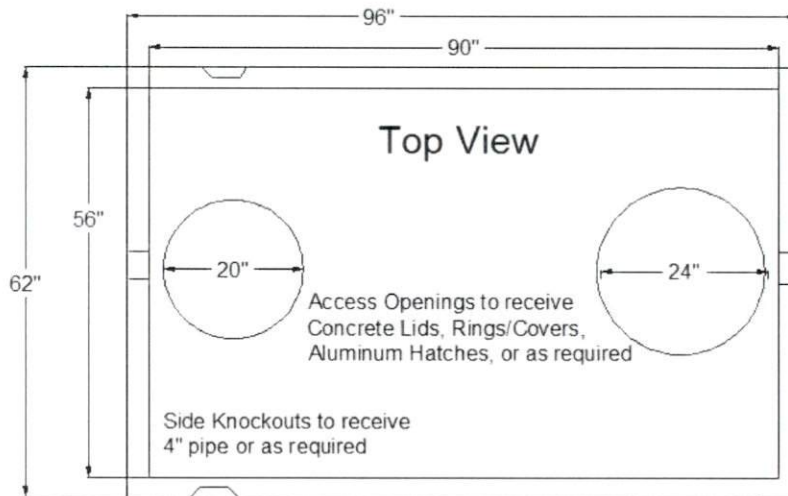

### PT - 213 Top seam

Date: 08-18-93

Non Traffic Rated

Liquid Capacity 1,211 Gallons

Reinforcing Schedule: # 3 Grade 60 Rebar

4500 PSI Concrete w/ State Approved Structural Fiber

2.5 yds. Est. Weight 8,900 lbs. 19 gals. per in.

Manufactured By:

# GARNERS

Septic Tanks, Inc.

Eddie Garner, President

919-718-5181

121 Stanton Hill Road

Carthage, NC 28327

Fax 919-775-2229

Eddie@garnersseptic tanks.com

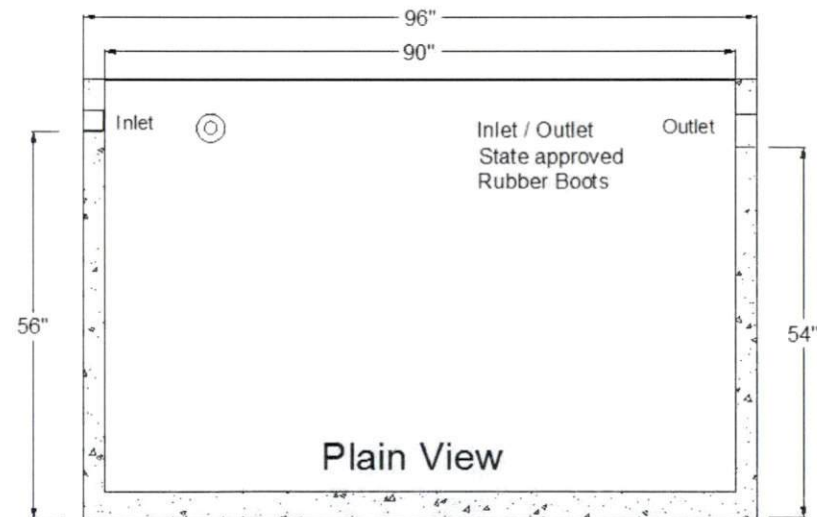
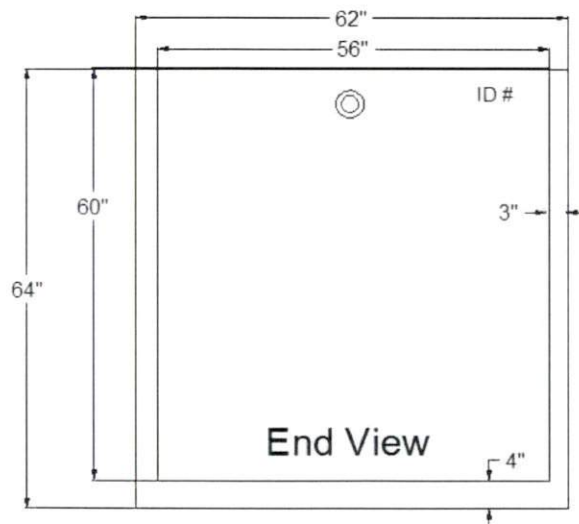
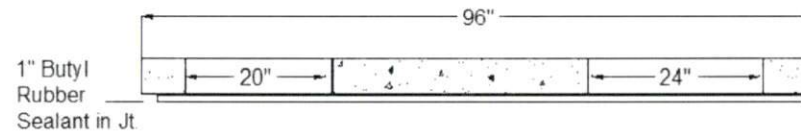
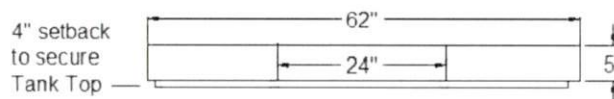



# INSTALLER FRIENDLY SERIES® - IFS Single Phase Simplex (Demand/TD)

Single phase, simplex demand dose or timed dose, float controlled system for pump control and system monitoring.

The IFS simplex control panel is designed to control one 120, 208, 240 VAC single phase pump in water and sewage installations.

The IFS control panel features an easy-to-use touch pad with display on the inner door for programming and system monitoring.

The panel configuration can be easily converted in the field to either a timed dose or demand dose.

## TOUCH PAD FEATURES

- A. **Float Indicators** illuminate when floats are activated. Alarm will activate if a float operates out of sequence.
- B. **HOA (Hand-Off-Automatic) Buttons** control pump mode with indication. Hand mode defaults to Automatic when stop level or redundant off level is reached.
- C. **Pump Run Indicator** illuminates when pump is called to run.
- D. **LED Display** shows system information including: mode, pump elapsed time (hh:mm), events (cycles), alarm counter, float error count, timed dose override counter (timed dose only), and ON/OFF times (timed dose only).
- E. **NEXT Push Button** toggles display.
- F. **UP and SET Push Buttons** set pump ON/OFF times (timed dose only).

## PANEL COMPONENTS

1. **Enclosure** base measures 10 X 8 X 4 inches (25.4 X 20.32 X 10.16 cm). NEMA 4X (ultraviolet stabilized thermoplastic with removable mounting feet for outdoor or indoor use). **Note:** Options, voltage, and amp range selected may change enclosure size and component layout.
2. **Red Alarm Beacon** provides 360° visual check of alarm condition.
3. **Exterior Alarm Test/Normal/Silence Switch** allows horn and light to be tested and horn to be silenced in an alarm condition. Alarm automatically resets once alarm condition is cleared.
4. **Alarm Horn** provides audio warning of alarm condition (83 to 85 decibel rating).
5. **Circuit Breaker** (optional) provides pump disconnect and branch circuit protection.
6. **Power Relay** controls pump by switching electrical lines. Definite purpose contactor used when pump full load amps are above 15.
7. **Float Connection Terminal Block**
8. **Incoming Control/Alarm Power & Pump Terminal Block**
9. **Control Power Indicator/Fuse** indicator light illuminates if control power is present in panel. Alarm will activate if control fuse is blown.
10. **Alarm Power Indicator/Fuse** indicator light illuminates if alarm power is present in panel.
11. **Ground Lug**

**NOTE:** Schematic/Wiring Diagram and Pump Specification Label are located inside the panel on enclosure cover

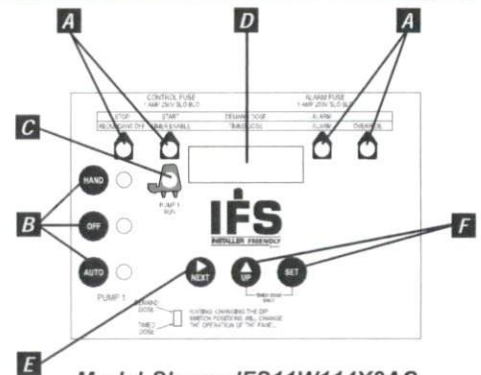

Model Shown IFS11W114X8AC  
(Inner door view)

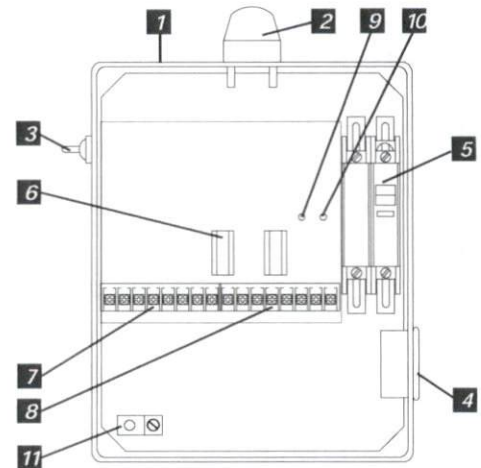

Model Shown IFS11W114X8AC  
(Inside view)

Reg. Cdn Pat. & TM Off

## FEATURES

- Entire control system (panel and switches) is UL Listed to meet and/or exceed industry safety standards
- Dual safety certification for the United States and Canada
- Standard package includes:  
**Demand Dose** - three 20' SJE MilliAmpMaster™ control switches  
**Timed Dose** - two 20' SJE MilliAmpMaster™ control switches
- Complete with step-by-step installation instructions
- Three-year limited warranty



**SJE Rhombus**

PO Box 1708, Detroit Lakes, MN 56502

1-888-DIAL-SJE • 1-218-847-1317

1-218-847-4617 Fax

email: sje@sjerhombus.com

[www.sjerhombus.com](http://www.sjerhombus.com)

SEE BACKSIDE FOR COMPLETE LISTING OF AVAILABLE OPTIONS.



IFS
2
1
W
Note
Note
4
H
8AC, 10E, 10F
15A

**MODEL IFS**

- MODEL TYPE**
- 1 = SPLX TIMED DOSE (includes option 8AC standard)
  - 2 = SPLX DEMAND DOSE (includes option 8AC standard)
- ALARM PACKAGE**
- 1 = alarm package (includes test/normal/silence switch, fuse, red light & horn)
- ENCLOSURE RATING**
- W = NEMA 4X
- STARTING DEVICE**
- 1 = 120/208/240 VAC
  - 9 = 120 VAC
- PUMP FULL LOAD AMPS**
- 0 = 0-7 FLA
  - 1 = 7-15 FLA
  - 2 = 15-20 FLA
- PUMP DISCONNECTS**
- 0 = no pump disconnect
  - 4 = circuit breaker  
 120 VAC (must select starting device option 9)  
 120/208/240 VAC (must select starting device option 1)
- SWITCH APPLICATIONS**
- H = floats (Timed dose = low level and alarm / Demand dose = stop, start, and alarm) (select 17 option)
  - X = no float  
 timed dose  
 demand Dose
- Note:** Pump down applications only.
- OPTIONS** *Listed below*

Note: Starting device, pump full load amps, cord length, and float type to be selected by installer and their electrician upon selection of pump.

**If additional features are required, call the factory for a quote on an Engineered Custom control panel.**

- | CODE                                | DESCRIPTION   |
|-------------------------------------|---|
| <input type="checkbox"/>            | 1J Duo alarm inputs   |
| <input type="checkbox"/>            | 3A Alarm flasher  |
| <input type="checkbox"/>            | 3B Manual reset alarm   |
| <input type="checkbox"/>            | 4A Redundant off (select option 4D if floats are required)<br>Demand Dose<br>Timed Dose   |
| <input type="checkbox"/>            | 4D Redundant off float  |
| <input type="checkbox"/>            | 6A Auxiliary alarm contacts, form C   |
| <input checked="" type="checkbox"/> | 8AC Display board includes: ETM counter, events (cycles) counter, alarm counter, and override counter (timed dose only). <b>(Included as standard.)</b> |
| <input checked="" type="checkbox"/> | 10E Lockable latch - NEMA 4X  |
| <input checked="" type="checkbox"/> | 10F Lightning arrestor (must select pump circuit breaker, control and alarm power combined)   |
| <input type="checkbox"/>            | 10K Anti-condensation heater  |
| <input type="checkbox"/>            | 11C NEMA 1 remote alarm panel<br>(must select option 6A)  |

- | CODE                                | DESCRIPTION   |
|-------------------------------------|---|
| <input type="checkbox"/>            | 11D NEMA 4X remote alarm panel<br>(must select option 6A) |
| <input checked="" type="checkbox"/> | 15A Control / Alarm circuit breaker                       |
| <input type="checkbox"/>            | 16A 10' cord in lieu of 20' (per float)                   |
| <input type="checkbox"/>            | 16B 15' cord in lieu of 20' (per float)                   |
| <input type="checkbox"/>            | 16C 30' cord in lieu of 20' (per float)                   |
| <input type="checkbox"/>            | 16D 40' cord in lieu of 20' (per float)                   |
| <input type="checkbox"/>            | 17C Sensor Float® / internally weighted ▲ (per float)     |
| <input type="checkbox"/>            | 17D Sensor Float® / externally weighted ▲ (per float)     |
| <input type="checkbox"/>            | 17G MilliAmpMaster™/ pipe clamp ● (per float)             |
| <input type="checkbox"/>            | 17H MilliAmpMaster™/ externally weighted ● (per float)    |
| <input type="checkbox"/>            | 17J Sensor Float® / pipe clamp ▲ (per float)              |
| <input type="checkbox"/>            | 18A Timer override option with float (timed dose only)    |
- Mechanically-activated    ▲ Mercury-activated

**SAMPLE**

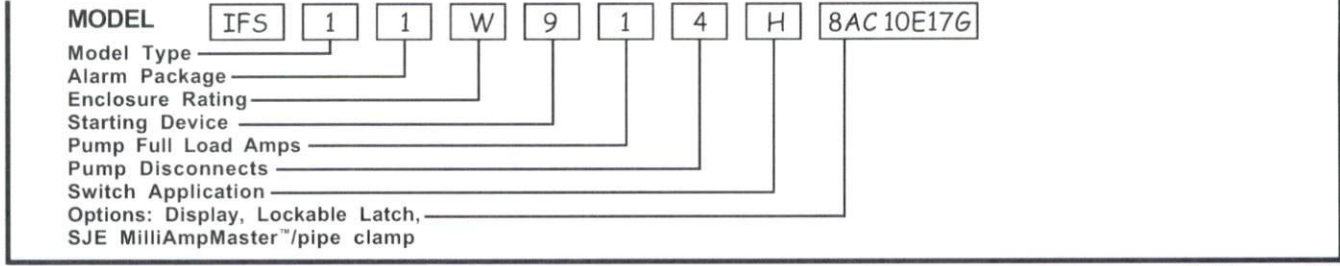

Product information presented here reflects conditions at time of publication. Consult factory regarding discrepancies or inconsistencies.



## TECHNICAL DATA SHEET

# DOSE-MATE SERIES

### Models 151, 152, 153 Effluent Pumps

#### PRODUCT SPECIFICATIONS

<b>MOTOR</b>	Horse Power	1/3 (151), 4/10 (152), 1/2 (153)
	Voltage	115 or 230
	Phase	1 Ph
	Hertz	60 Hz
	RPM	3450
	Type	Permanent split capacitor
	Insulation	Class B
	Amps	3.0 - 10.5
<b>PUMP</b>	Operation	Automatic or nonautomatic
	Discharge Size	1-1/2" NPT
	Solids Handling	1/2" (12 mm), 3/4" (19 mm) spherical solids
	Cord Length	20' (6 m)
	Cord Type	UL listed power cord
	Max. Head	44' (13.4 m)
	Max. Flow Rate	77 GPM (291 LPM)
	Max. Operating Temp.	130 °F (54 °C)
	Cooling	Oil filled
	Motor Protection	Auto reset thermal overload
	<b>MATERIALS</b>	Cap
Motor Housing		Cast iron
Pump Housing		Cast iron
Base		Plastic or cast iron
Upper Bearing		Sleeve bearing
Lower Bearing		Ball bearing
Mechanical Seals		Carbon and ceramic
Impeller Type		Non-clogging vortex
Impeller		Engineered thermoplastic
Hardware		Stainless steel
Motor Shaft		AISI 1215 steel
Gasket		Neoprene

#### MODEL 151

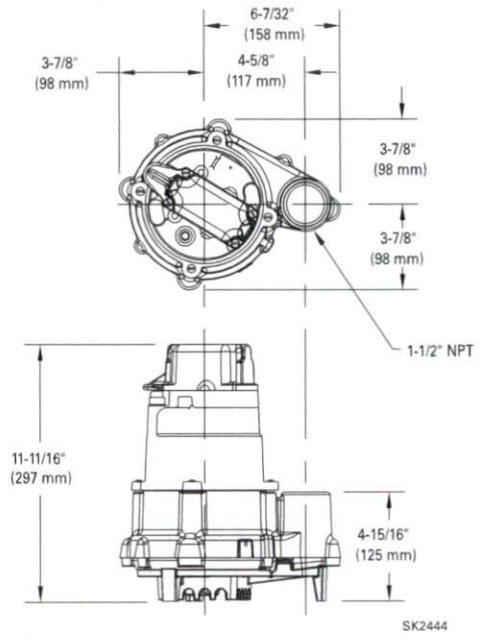

#### MODELS 152 & 153

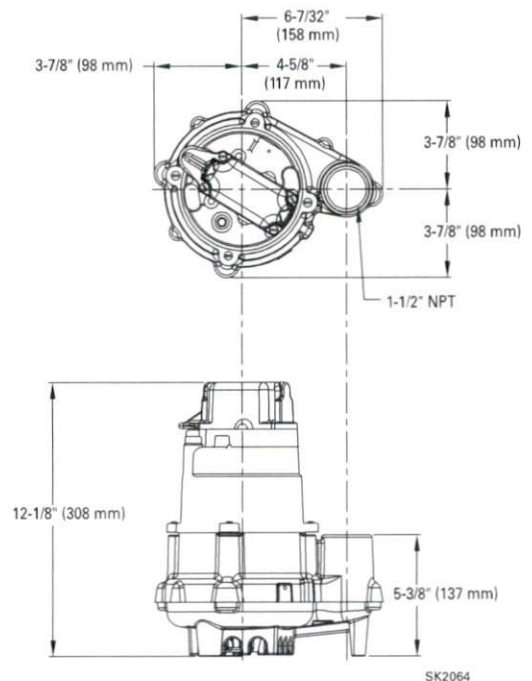

NOTE: The sizing of effluent systems normally requires variable level float(s) controls and properly sized basins to achieve required pumping cycles or dosing timers with nonautomatic pumps.

NOTE: See model comparison chart for specific details.





## TOTAL DYNAMIC HEAD FLOW PER MINUTE

MODEL		151		152		153	
Feet	Meters	Gal.	Liters	Gal.	Liters	Gal.	Liters
5	1.5	50	189	69	261	77	291
10	3.0	45	170	61	231	70	265
15	4.6	38	144	53	201	61	231
20	6.1	29	110	44	167	52	197
25	7.6	16	61	34	129	42	159
30	9.1	--	--	23	87	33	125
35	10.7	--	--	--	--	22	85
40	12.2	--	--	--	--	11	42
Shut-off Head:		30 ft. (9.1m)		38 ft. (11.6m)		44 ft. (13.4m)	

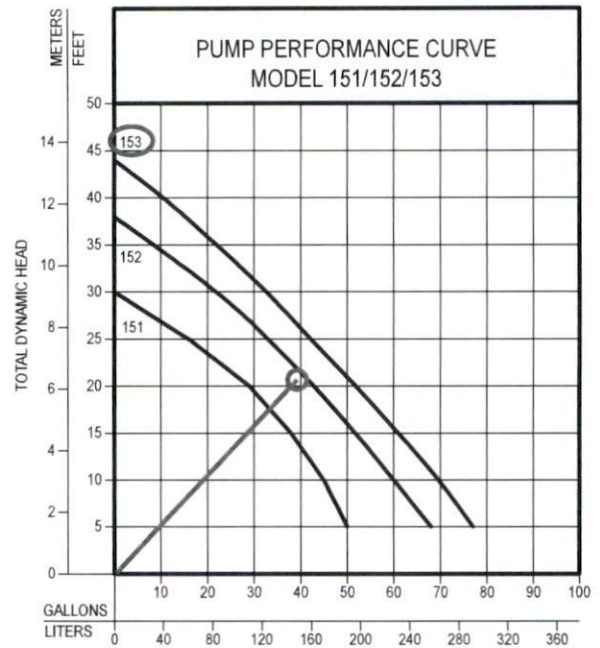

014508

Model	MODEL COMPARISON										
	Seal	Mode	Volts	Ph	Amps	HP	Hz	Lbs	Kg	Simplex	Duplex
N151	Single	Non	115	1	6.0	1/3	60	32	15	1	2 or 3
E151	Single	Non	230	1	3.0	1/3	60	32	15	1	2 or 3
BN151	Single	Auto	115	1	6.0	1/3	60	33	15	*	2 or 3
BE151	Single	Auto	230	1	3.0	1/3	60	33	15	*	2 or 3
N152	Single	Non	115	1	8.5	4/10	60	37	17	1	2 or 3
E152	Single	Non	230	1	4.3	4/10	60	37	17	1	2 or 3
BN152	Single	Auto	115	1	8.5	4/10	60	39	18	*	2 or 3
BE152	Single	Non	230	1	4.3	4/10	60	39	18	*	2 or 3
N153	Single	Non	115	1	10.5	1/2	60	37	17		
BN153	Single	Auto	115	1	10.5	1/2	60	39	18	*	2 or 3
E153	Single	Non	230	1	5.3	1/2	60	37	17	1	2 or 3
BE153	Single	Non	230	1	5.3	1/2	60	39	18	*	2 or 3

\*BN and BE models include a 20' (6 m) piggyback variable level pump switch. Additional cord lengths are available in 25' (8 m) and 35' (11 m). 50' (15 m) cords are available for 230 V units only.

NOTE: Model 151 has a plastic base. Models 152 & 153 have a cast iron base.

### SELECTION GUIDE

- For automatic, use single piggyback variable level float switch or double piggyback variable level float switch. Refer to FM0477.
- See FM1228 for correct model of simplex control panel.
- See FM0712 for correct model of duplex control panel.

#### OPTIONAL PUMP STAND P/N 10-2421

- Reduces potential clogging by debris
  - Replaces rocks or bricks under the pump
  - Made of durable, noncorrosive ABS
  - Raises pump 2" (5 cm) off bottom of basin
  - Provides the ability to raise intake by adding sections of 1/2" or 2" (DN40 or DN50) PVC piping
  - Attaches securely to pump
  - Accommodates sump, dewatering and effluent applications
- NOTE: Make sure float is free from obstruction.

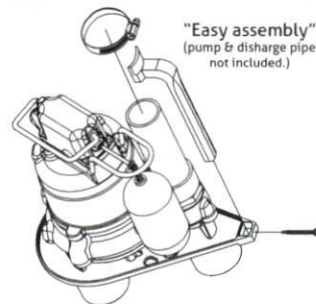

#### CAUTION

All installation of controls, protection devices and wiring should be done by a qualified licensed electrician. All electrical and safety codes should be followed including the most recent National Electrical Code (NEC) and the Occupational Safety and Health Act (OSHA).

© Copyright 2017 Zoeller® Co. All rights reserved.

502-778-2731 | 800-928-7867 | 3649 Cane Run Road | Louisville, KY 40211-1961 | zoellerpumps.com



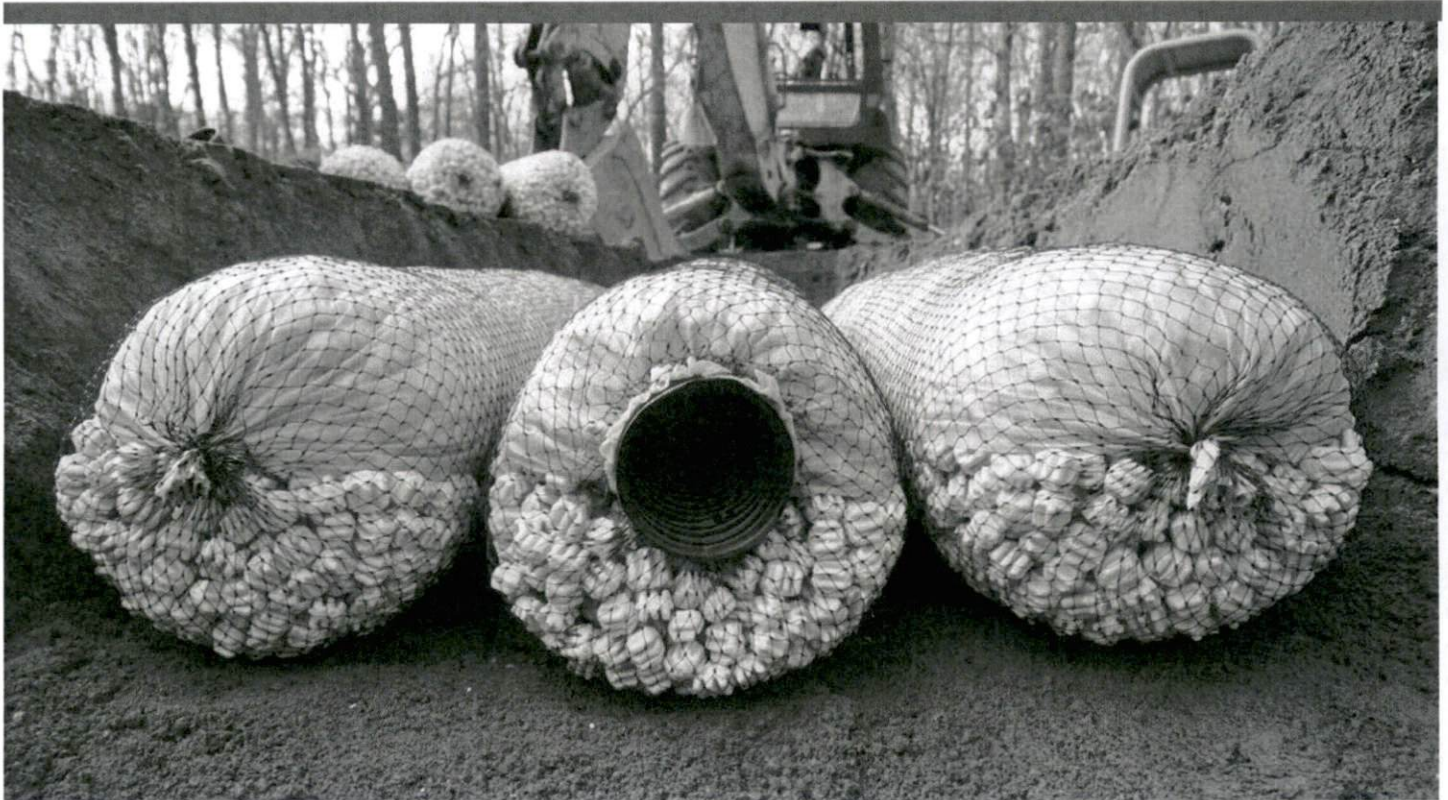

EZflow by Infiltrator is an environmentally friendly replacement to traditional stone and pipe drainfields using an engineered geosynthetic aggregate modular design. The EZflow system is designed to improve infiltration performance by eliminating the fines associated with crushed stone, and reducing compaction and embedment associated with stone. Preassembled units include a 3" or 4" perforated pipe surrounded by aggregate and held in place with a durable high-strength netting. This product comes in easy-to-contour 5' and 10' lengths and in diameters of 7, 8, 9, 10, 12, 13, or 14 inches.

**Lightweight expanded polystyrene**

construction offers structural integrity and resists compaction. Engineered flow-channels increase void space creating improved water flow and greater storage.



## Compared with stone and pipe, benefits include:

- Always clean and free of fines
- Bundles are quick to install, saving costs on heavy machinery and labor
- Modular construction allows configurations to match trench dimensions for most system shapes and sizes
- Engineered for optimal storage and absorption efficiencies
- Ability to contour along sloped sites and around trees or landscaping
- Lightweight system is perfect for repairs and tight job sites
- Easily hand-carried into position reducing time and labor
- 5' or 10' lengths with simple snap, internal couplers
- Easier cleanup at the job site with the elimination of stone
- Manufactured from recycled materials rather than a mined natural resource
- A wide variety of diameters and configurations to meet any installation professional's needs
- Approved in many jurisdictions with an increased efficiency rating, reducing drainfield size
- Backed by the leader in the onsite wastewater industry





**Bundle System Configurations:** Available in 7", 8", 9", 10", 12", 13" and 14" diameter bundles.

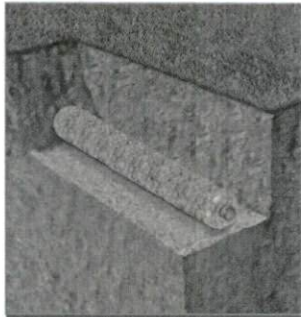

**Single Bundle**

0701P-GEO    1201P-GEO  
 0801P-GEO    1401P-GEO  
 1201P-GEO    1801P-GEO  
 1001P-GEO

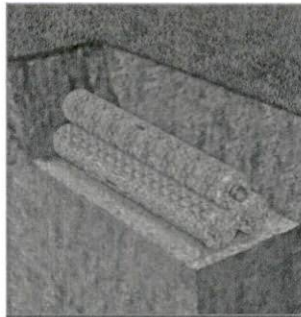

**Triangular Bundle**

1003T-GEO    1303T-GEO  
 1203T-GEO    1403T-GEO

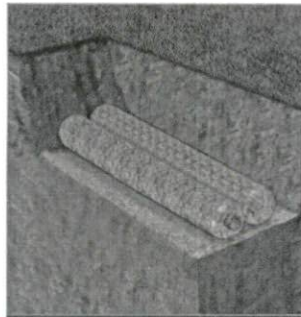

**Horizontal Bundles**

0705H-GEO    1303H-GEO  
 0904H-GEO    1202H-GEO  
 1002H-GEO    1203H-GEO

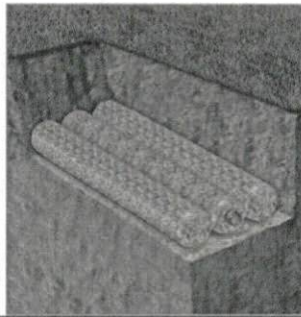

1206H-GEO    1402H-GEO  
 1303H-GEO    1802H-GEO

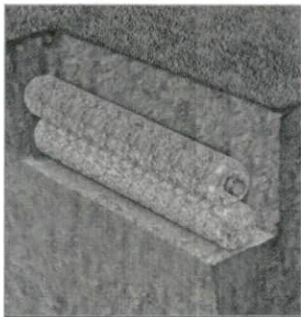

**Vertical Bundles**

1002V-GEO    1006V-GEO    1203V-GEO    1206V-GEO  
 1003V-GEO    1202V-GEO    1204V-GEO    1402V-GEO  
 1004V-GEO

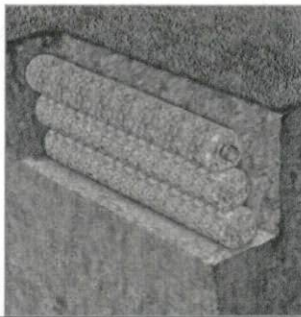

**Notes:**

1. Other systems include 10" and 12" bed systems. Bed size will dictate the number of bundles.
2. System dimensions are dependent upon bundle diameter and configuration.
3. LLP is for "Low Pressure Pipe" in which a pressurized distribution pipe is field installed within the corrugated pipe.
4. Internal pipe and couplings meet the requirements of ASTM F405.
5. Bundles are also available without geotextile between the netting and synthetic aggregate.

**INFILTRATOR WATER TECHNOLOGIES STANDARD LIMITED WARRANTY**

(a) The structural integrity of each EZflow by Infiltrator expanded polystyrene drainfield system and other accessories manufactured by EZflow by Infiltrator ("Units"), when installed and operated in a leachfield of an onsite septic system in accordance with Infiltrator's instructions, is warranted to the original purchaser ("Holder") against defective materials and workmanship for one year from the date that the septic permit is issued for the septic system containing the Units; provided, however, that if a septic permit is not required by applicable law, the warranty period will begin upon the date that installation of the septic system commences. To exercise its warranty rights, Holder must notify Infiltrator in writing at its Corporate Headquarters in Old Saybrook, Connecticut within fifteen (15) days of the alleged defect. Infiltrator will supply replacement Units for Units determined by EZflow by Infiltrator to be covered by this Limited Warranty. EZflow by Infiltrator's liability specifically excludes the cost of removal and/or installation of the Units.

(b) THE LIMITED WARRANTY AND REMEDIES IN SUBPARAGRAPH (a) ARE EXCLUSIVE. THERE ARE NO OTHER WARRANTIES WITH RESPECT TO THE UNITS, INCLUDING NO IMPLIED WARRANTIES OF MERCHANTABILITY OR FITNESS FOR A PARTICULAR PURPOSE

(c) This Limited Warranty shall be void if any part of the EZflow system is manufactured by anyone other than EZflow by Infiltrator. The Limited Warranty does not extend to incidental, consequential, special or indirect damages. Infiltrator shall not be liable for penalties or liquidated damages, including loss of production and profits, labor and materials, overhead costs, or other losses or expenses incurred by the Holder or any third party. Specifically excluded from Limited Warranty coverage are damage to the Units due to ordinary wear and tear, alteration, accident, misuse, abuse or neglect of the Units; the Units being subjected to vehicle traffic or other conditions which are not permitted by the installation instructions; failure to maintain the minimum ground covers set forth in the installation instructions; the placement of improper materials into the system containing the Units; failure of the Units or the septic system due to improper siting or improper sizing, excessive water usage, improper grease disposal, or improper operation; or any other event not caused by Infiltrator. This Limited Warranty shall be void if the Holder fails to comply with all of the terms set forth in this Limited Warranty. Further, in no event shall Infiltrator be responsible for any loss or damage to the Holder, the Units, or any third party resulting from installation or shipment, or from any product liability claims of Holder or any third party. For this Limited Warranty to apply, the Units must be installed in accordance with all site conditions required by state and local codes; all other applicable laws; and Infiltrator's installation instructions.

(d) No representative of Infiltrator has the authority to change or extend this Limited Warranty. No warranty applies to any party other than the original Holder.

The above represents the Standard Limited Warranty offered by Infiltrator. A limited number of states and counties have different warranty requirements. Any purchaser of Units should contact Infiltrator's Corporate Headquarters in Old Saybrook, Connecticut, prior to such purchase, to obtain a copy of the applicable warranty, and should carefully read that warranty prior to the purchase of Units.



4 Business Park Road  
 P.O. Box 768  
 Old Saybrook, CT 06475  
 860-577-7000 • Fax 860-577-7001  
**1-800-221-4436**  
[www.infiltratorwater.com](http://www.infiltratorwater.com)

U.S. Patents: 4,759,661; 5,017,041; 5,156,488; 5,336,017; 5,401,116; 5,401,459; 5,511,903; 5,716,163; 5,588,778; 5,839,844 Canadian Patents: 1,329,959; 2,004,564 Other patents pending. Infiltrator, Equalizer, Quick4, and SideWinder are registered trademarks of Infiltrator Water Technologies. Infiltrator is a registered trademark in France. Infiltrator Water Technologies is a registered trademark in Mexico. Contour, MicroLeaching, PolyTuff, ChamberSpacer, MultiPort, PosiLock, QuickCut, QuickPlay, SnapLock and StraightLock are trademarks of Infiltrator Water Technologies. PolyLok is a trademark of PolyLok, Inc. TUF-TITE is a registered trademark of TUF-TITE, INC. Ultra-Rib is a trademark of IPEX Inc.

© 2015 Infiltrator Water Technologies, LLC. All rights reserved. Printed in U.S.A.

EO1 0315AG

**Contact Infiltrator Water Technologies' Technical Services Department for assistance at 1-800-221-4436**

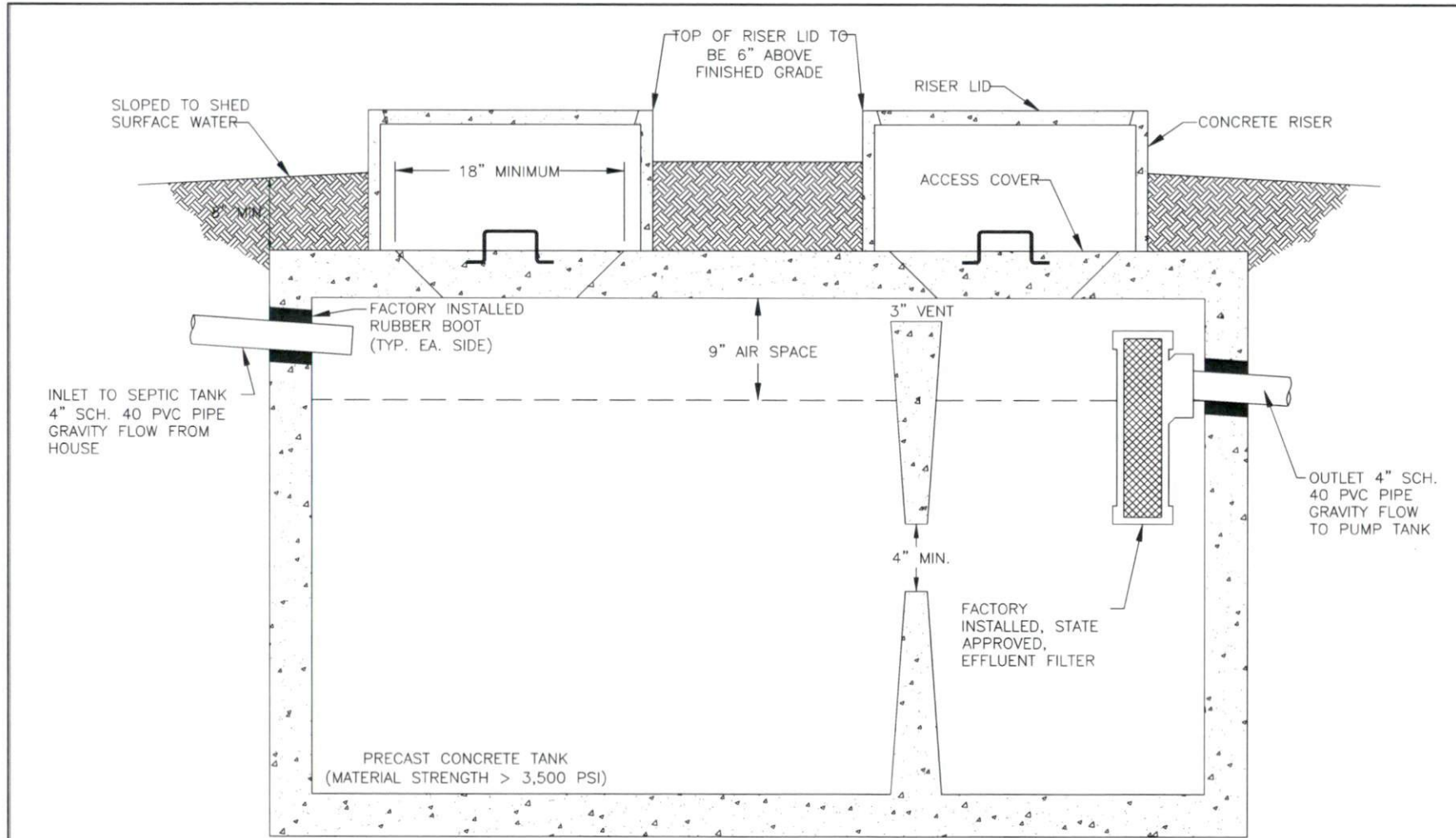

1,000 GALLON SEPTIC TANK

**SEPTIC TANK DETAIL**

N.T.S.

<p><b>MITCHELL ENVIRONMENTAL, PA</b> C-2911</p> <p>1501 LAKESTONE VILLAGE LANE SUITE 205 FUQUAY VARINA, NC 27526</p>		<p>Division Homes PREPARED FOR : 330 James Record Road Rochester, N. C. 2824</p>	<p>REVISION NO. Original Submitted Revision 1 Revision 2 Revision 3 Master Set</p>	<p>DATE October 19, 2021</p>	<p><b>SHEET NUMBER</b>  4 of 7</p>
<p>DATE : October 19, 2021 ENGINEER AND SEAL SCIENTIST CONTACT: SCOTT MITCHELL, P.E., L.S. DRAWN BY: ADAM AYCOCK, D</p>		<p>Prince Place Lot 11 Septic Tank Detail</p>			

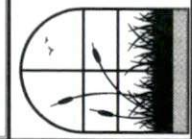





## PRESSURE MANIFOLD DETAIL FOR PRINCE PLACE LOT 11 INITIAL SEPTIC SYSTEM

N.T.S.

NOTE: MANIFOLD MAY NEED TO BE FLIPPED SO THAT  
SUPPLY LINE ENTRANCE AND CLEANOUTS ARE  
REVERSED. SEE SITE PLAN.

NOTE: THE NUMBER OF TAPS MAY VARY FROM LOT  
TO LOT. SEE DESIGN SHEET FOR NUMBER OF TAPS.

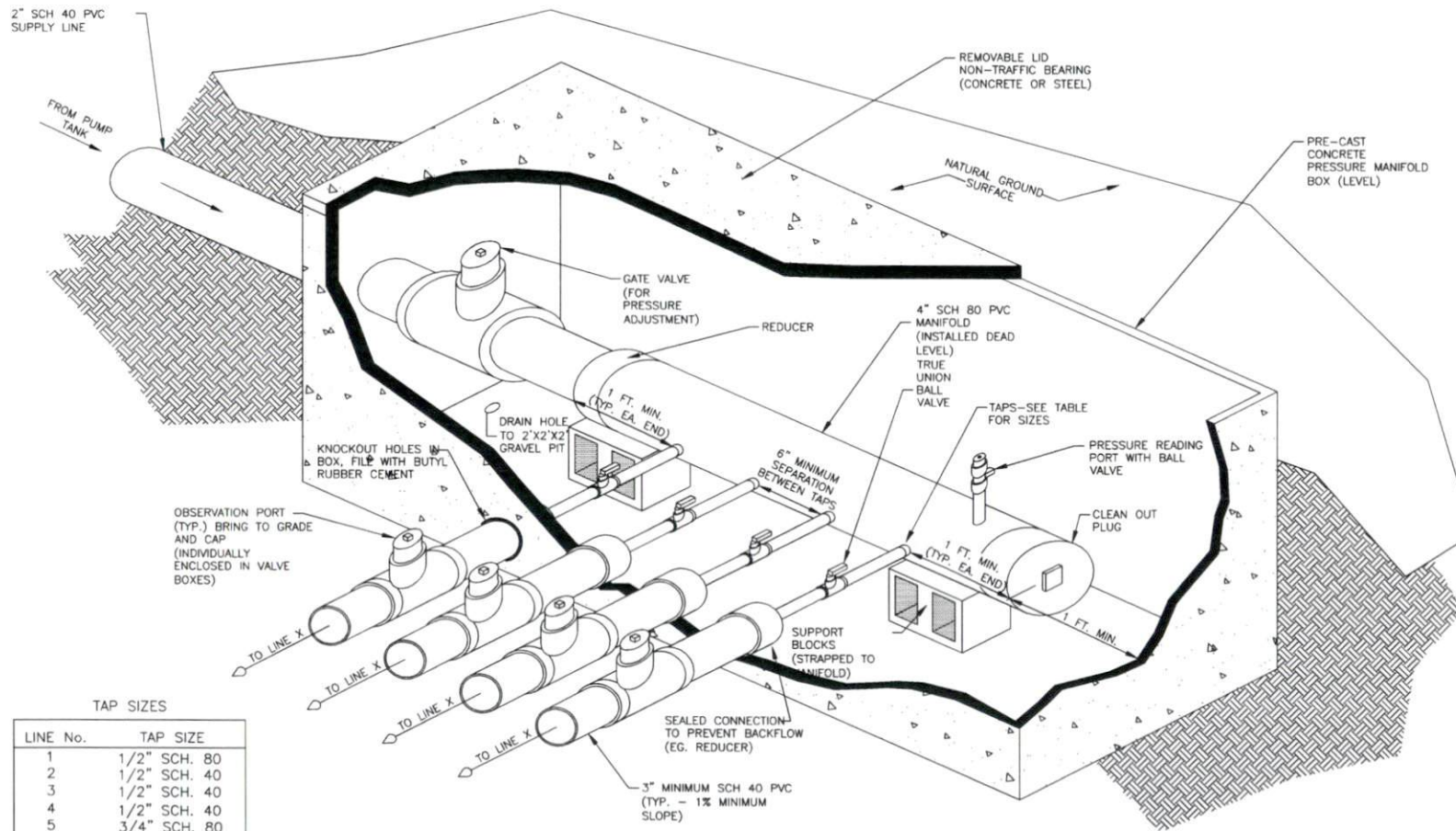

TAP SIZES

LINE No.	TAP SIZE
1	1/2" SCH. 80
2	1/2" SCH. 40
3	1/2" SCH. 40
4	1/2" SCH. 40
5	3/4" SCH. 80

SHEET NUMBER  
**6 of 7**  
Prince Place  
Lot 11  
Pressure Manifold Detail

REVISION NO.	DATE
Original Submittal	October 19, 2021
Revision 1	
Revision 2	
Revision 3	
Master Set	

Prepared For: Davidson Homes  
336 James Record Road  
Huntsville, AL 35824

DATE: October 19, 2021

ENGINEER AND SOIL SCIENTIST CONTACT:  
SCOTT MITCHELL, P.E., LSS

DRAWN BY:  
ADAM AYCOCK, E

**MITCHELL ENVIRONMENTAL, PA**  
C-2977

1501 LAKESTONE VILLAGE LANE  
SUITE 205  
FUQUAY VARINA, NC 27526

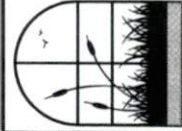



# NITRIFICATION TRENCH DETAIL FOR EZ-FLOW

N.T.S.

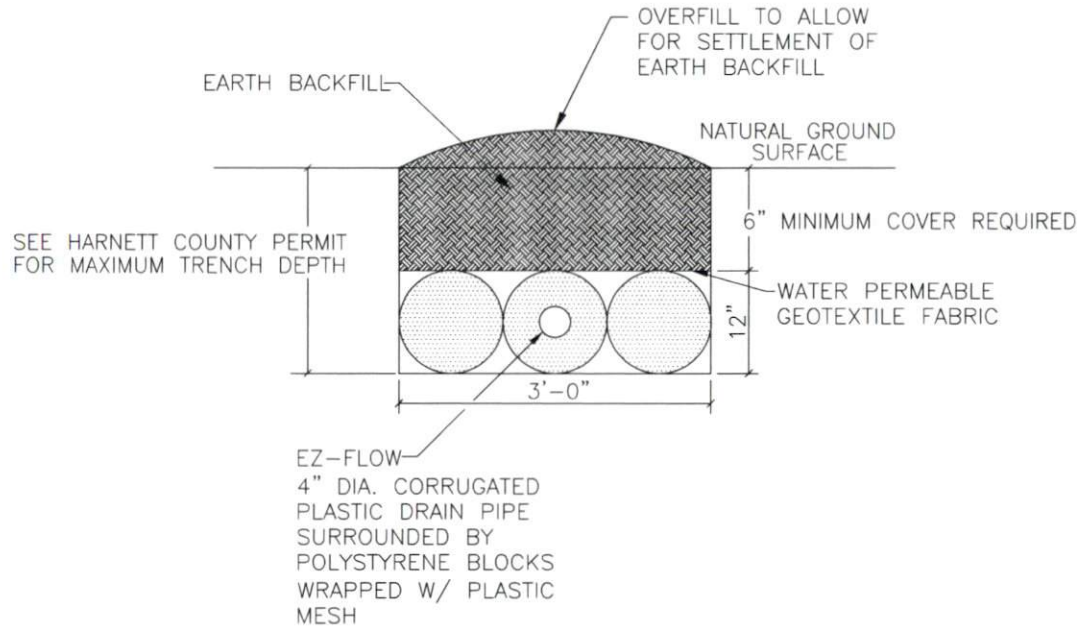

**NOTES:**

1. PERFORATED CORRUGATED PLASTIC PIPE SHALL MEET REQUIREMENTS OF ASTM D 2729.
2. PIPE SHALL BE LEVEL.
3. ENDCAP SHALL BE PROVIDED AT END OF ALL CORRUGATED PLASTIC PIPE LINES.
4. TRENCH BOTTOM SHALL BE LEVEL.
5. HAND RAKE TRENCH WALLS PRIOR TO PLACEMENT OF TRENCH MEDIA IF SOIL SMEARING IS PRESENT.

**MITCHELL ENVIRONMENTAL, PA**  
C-2911

1501 LAKESTONE VILLAGE LANE  
SUITE 205  
FUQUAY VARINA, NC 27526



PREPARED FOR : Davison Homes 330 Jenna Record Road Huntsville, AL 35824	REVISION NO. Original Submittal Revision 1 Revision 2 Revision 3 Master Set	DATE October 19, 2021 ----- ----- ----- -----	SHEET NUMBER  <b>7 of 7</b>
ENGINEER AND SEAL DESIGNER CONTACT: SCOTT MITCHELL, P.E., L.S. DRAWN BY: ADAM AYCOCK, D			Prince Place Lot 11 Trench Detail