

Harnett County Department of Public Health Improvement Permit

A building permit cannot be issued with only an Improvement Permit

ISSUED TO: Davidson Homes, LLC PROPERTY LOCATION: 21 Royal Ella Ct. (Christian Light Rd. - SR
 SUBDIVISION Prince Place LOT # 9
 NEW REPAIR EXPANSION Site Improvements required prior to Construction Authorization Issuance:
 Type of Structure: 40x56 sfd, 4 beds 3.5 baths
 Proposed Wastewater System Type: 25% Reduction Sys.
 Projected Daily Flow: 480 GPD
 Number of bedrooms: 4 Number of Occupants: 8 max
 Basement Yes No
 Pump Required: Yes No May be required based on final location and elevations of facilities
 Type of Water Supply: Community Public Well Distance from well NA feet Permit valid for: Five years
 Permit conditions: _____ No expiration

Authorized State Agent: [Signature] Date: 11/05/2021 SEE ATTACHED SITE SKETCH
 The issuance of this permit by the Health Department in no way guarantees the issuance of other permits. The permit holder is responsible for checking with appropriate governing bodies in meeting their requirements. This site is subject to revocation if the site plan, plat, or the intended use changes. The Improvement Permit shall not be affected by a change in ownership of the site. This permit is subject to compliance with the provisions of the Laws and Rules for Sewage Treatment and Disposal and to conditions of this permit.

Construction Authorization (Required for Building Permit)

The construction and installation requirements of Rules .1950, .1952, .1954, .1955, .1956, .1957, .1958, and .1959 are incorporated by references into this permit and shall be met. Systems shall be installed in accordance with the attached system layout.

ISSUED TO: Davidson Homes, LLC PROPERTY LOCATION: 21 Royal Ella Ct. (Christian Light Rd. - S
 SUBDIVISION Prince Place LOT # 9
 Facility Type: 40x56 sfd, 4 beds 3.5 bat New Expansion Repair
 Basement? Yes No Basement Fixtures? Yes No
 Type of Wastewater System** Pump to 25% Reduction System (Initial) Wastewater Flow: 480 GPD
 (See note below, if applicable
Pump to 25% Reduction System (Repair)
 Installation Requirements/Conditions
 Septic Tank Size 1000 gallons Number of trenches 4
 Pump Tank Size 1200 gallons Exact length of each trench Multi feet Trench Spacing: 9 Feet on Center
 Trenches shall be installed on contour at a Soil Cover: 12 inches
 Maximum Trench Depth of: 24 inches (Maximum soil cover shall not exceed
 (Trench bottoms shall be level to +/-1/4" 36" above the trench bottom)
 in all directions)
 Pump Requirements: _____ ft. TDH vs. _____ GPM Aggregate Depth: NA inches below pipe
 _____ inches above pipe
 Conditions: Proposal by Mitchell Enviromental / Pressure Manifold (specs attac NA inches total

**WATER LINES (INCLUDING IRRIGATION) MUST BE 10FT. FROM ANY PART OF SEPTIC SYSTEM OR REPAIR AREA.
 NO UTILITIES ALLOWED IN INITIAL OR REPAIR DRAIN FIELD AREA.**

**If applicable: I understand the system type specified is different from the type specified on the application. I accept the specifications of this permit.
 Owner/Legal Representative Signature: _____ Date: _____

This Construction Authorization is subject to revocation if the site plan, plat, or the intended use changes. The Construction Authorization shall not be transferred when there is a change in ownership of the site. This Construction Authorization is subject to compliance with the provisions of the Laws and Rules for Sewage Treatment and Disposal and to the conditions of this permit. SEE ATTACHED SITE SKETCH

Authorized State Agent: [Signature] Date: 11/05/2021
Andrew Wilson Construction Authorization Expiration Date: 11/05/2026

Application # SFD2110-0101

Harnett County Department of Public Health Site Sketch

Property Location: 21 Royal Ella Ct. (Christian Light Rd. - SR 1412)

Issued To: Davidson Homes, LLC

Subdivision Prince Place

Lot # 9

Authorized State Agent: _____



Date: 11/05/2021

ANDREW WREN

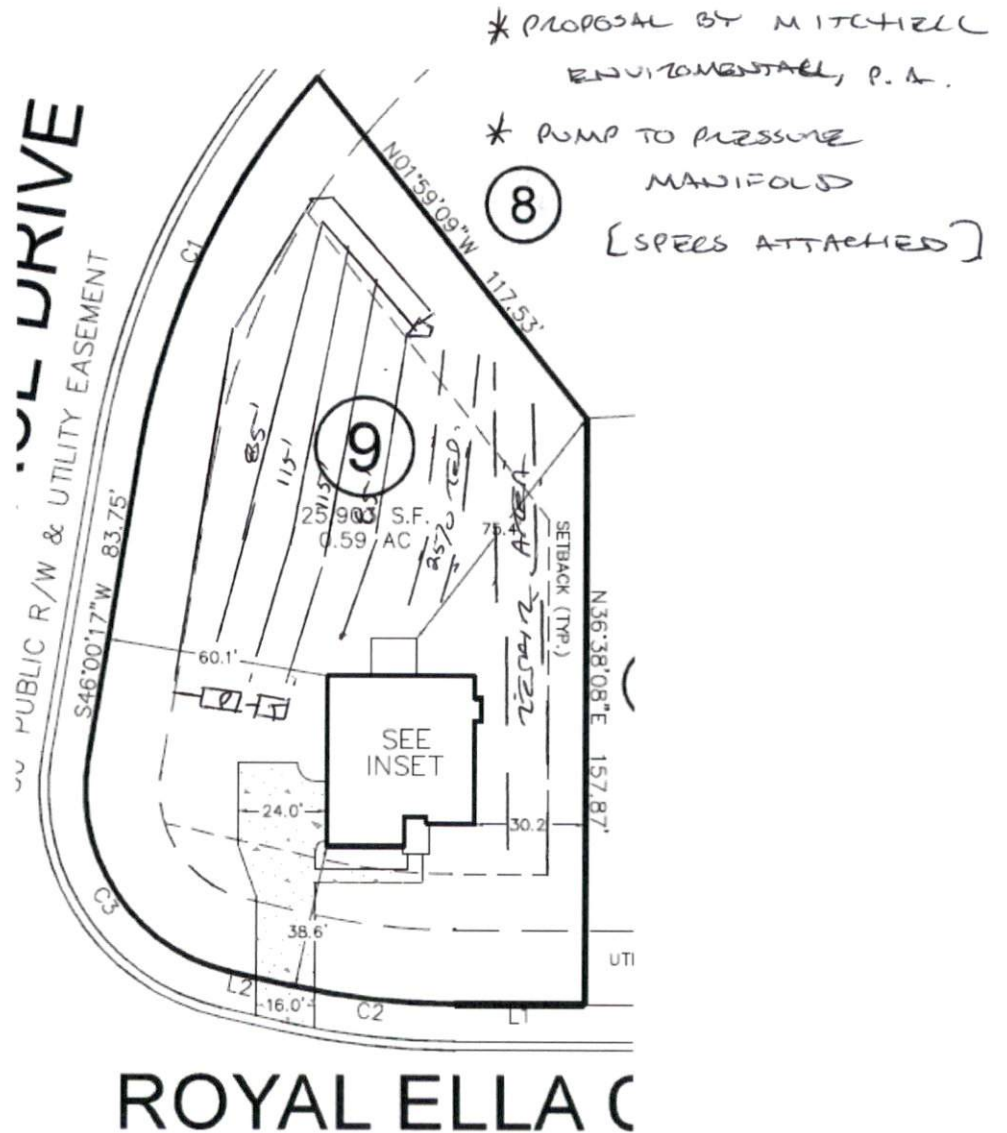

This drawing is for illustrative purposes only. System installation must meet all pertinent laws, rules, and regulations.

Mitchell Environmental, P.A.

SEPTIC SYSTEM DESIGN

for

PRINCE PLACE SUBDIVISION- LOT 9

Fuquay-Varina, Harnett County, North Carolina

Submitted to:

Harnett County Health Department
307 Cornelius Harnett Blvd.
Lillington, NC 27546

Prepared for:

Davidson Homes, LLC
336 James Record Road
Huntsville, Alabama 35824

Prepared by:

Scott Mitchell, PE, LSS
Adam Aycok, EI

DATE: October 12, 2021

PROJECT NO.: 4321

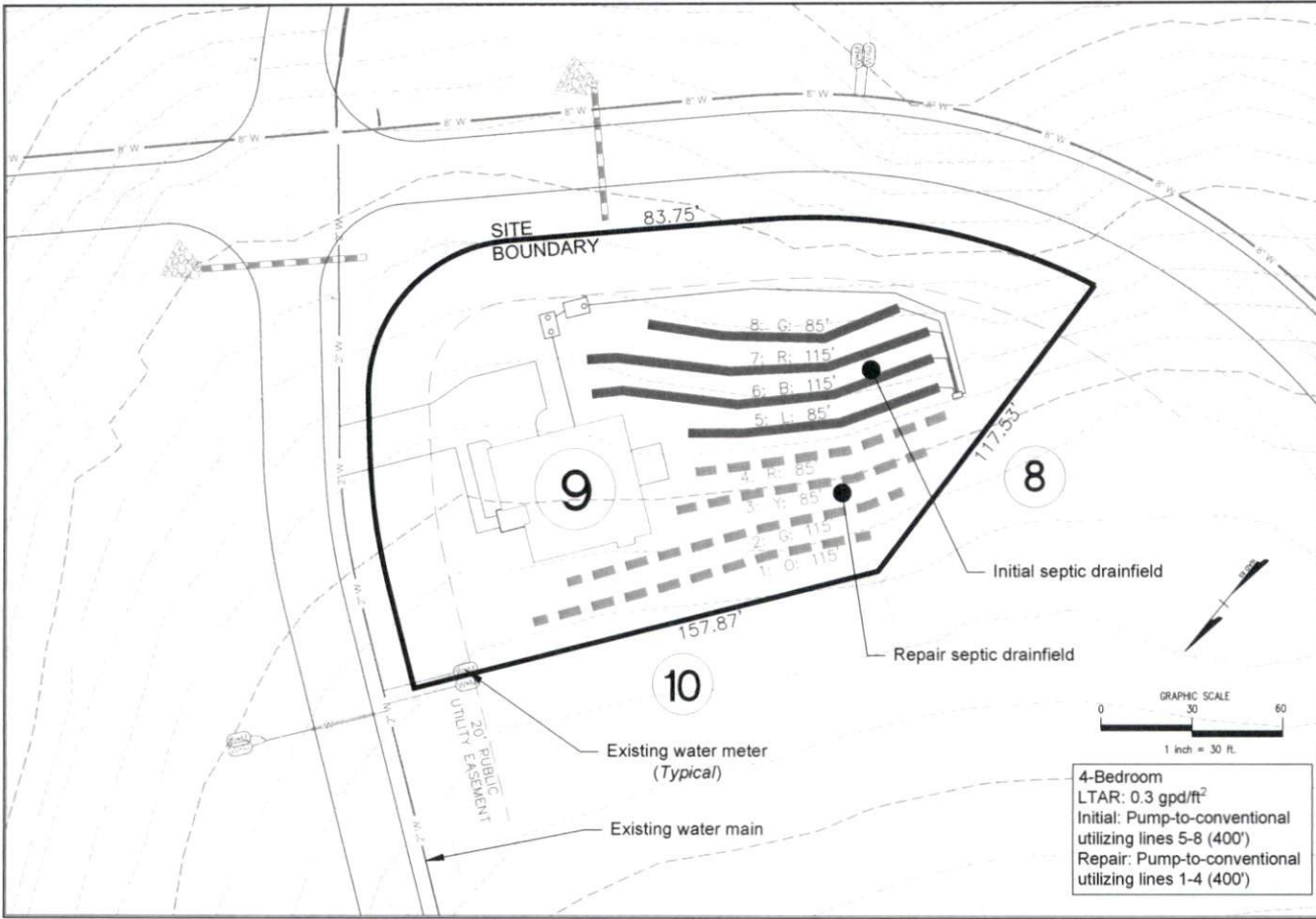

REVISION NO.	DATE	SHEET NUMBER
Original Submittal	October 12, 2007	1 of 7
Revision 1		Prince Place Lot 9 Overall Septic
Revision 2		
Revision 3		
Master Set		
Prepared For: Division Name: Original Submittal: Date: October 12, 2007	Prepared By: Scott Mitchell, P.E., L.S.	Checked and Seal: Adam Kitcher, E.I.
MITCHELL ENVIRONMENTAL, PA C-2811 1501 LAKESTONE VILLAGE LANE SUITE 205 PUQUAY VARINA, NC 27526		

PRESSURE MANIFOLD DESIGN

Name: Davidson Homes P.I.N. #: 0633-76-7692 D #: N/A
 Address: Prince Place Drive Subdiv: Prince Place Lot#: 9
 # of BDR: 4 Daily Flow: 480 gal/day L.T.A.R.: 0.300 gal/day/sq.ft
 Septic Tank: 1000 gals (min.) Pump Tank: 1200 gals (min.) Sq. Foot: 1200 Stone Depth: N/A
 (EZ Flow)
 Number of Taps: 4 Length of Trenches: Varies ft(See Tap Chart for Details)
 Depth of Trenches: see Harnett County Permit Manifold Length: 42 in
 Manifold Diameter: 4 in sch 80pvc (minimum) Tap Configuration: 6 in spacing 1 side(s) of manifold
 Supply Line: length: 150 ft Diameter: 2 in sch 40pvc
 Friction Loss + Fitting Loss: 3.32 ft(supply line length + 70' for fittings in pump tank)
 Design Head: 2.0 ft Elevation Head: 7.87 ft
 Vent Hole Size: 3/16 in Orifice Coefficient of Discharge: 0.60
 Orifice Coefficient of Contraction: 0.62 Orifice Coefficient of Velocity: 0.97
 Maximum Head Supplied by Selected Pump(s) at Total Design Flowrate: 22 ft
 Orifice / Vent Hole Flowrate: 1.94 gpm Head Loss at Orifice / Vent Hole: 1.40 ft
 Total Head: 14.59 ft Pump to Deliver: 27.12 gals/min at 14.59 ft head
 Dosing Volume: 171.60 gals.
 Drawdown: 171.60 gals divided by 19 gals/in = 9.03 inches
 SJE Rhombus Installer Friendly Series simplex control panel, or equivalent, required
 A septic tank filter, or equal is required.
 Possible pumps: Hydromatic: Goulds: Myers:
 Zoeller: 137 Other:

TAP CHART

Bench Mark	5.03	is = 100.00	set at	Top EIR 9/10 rear corner	Design Head:	2.0			
Pump tank elev.	10.6	94.43	Pump elev.	89.43	Manifold elev.	97.30			
line	color	rod read	Elevation	length	hole size	flow/tap	gal/day	trench area	LINE LTAR
5	Lime	8.23	96.80	85	1/2in SCH 80	5.48	104.46	255	0.4097
6	Blue	8.92	96.11	115	1/2in SCH 40	7.11	135.54	345	0.3929
7	Red	9.71	95.32	115	1/2in SCH 40	7.11	135.54	345	0.3929
8	Green	10.58	94.45	85	1/2in SCH 80	5.48	104.46	255	0.4097
		total	feet =	400	gal/min =	25.2	LTAR =		0.3000
% of Pipe Vol.	<u>66</u>		Des. Flow	480.00		(Itar + 5%)		0.3150	
Dose Volume	171.60		Pump Run=	19.06		(Itar W/ INOV)		0.4000	
Dose Pump Time	6.81		Tank Gal/IN	19		(Itar + 5%)		0.4200	
Drawdown in Inches	9.03		Elev. Head	7.87					
Supply Line Length	150								
Comments:									

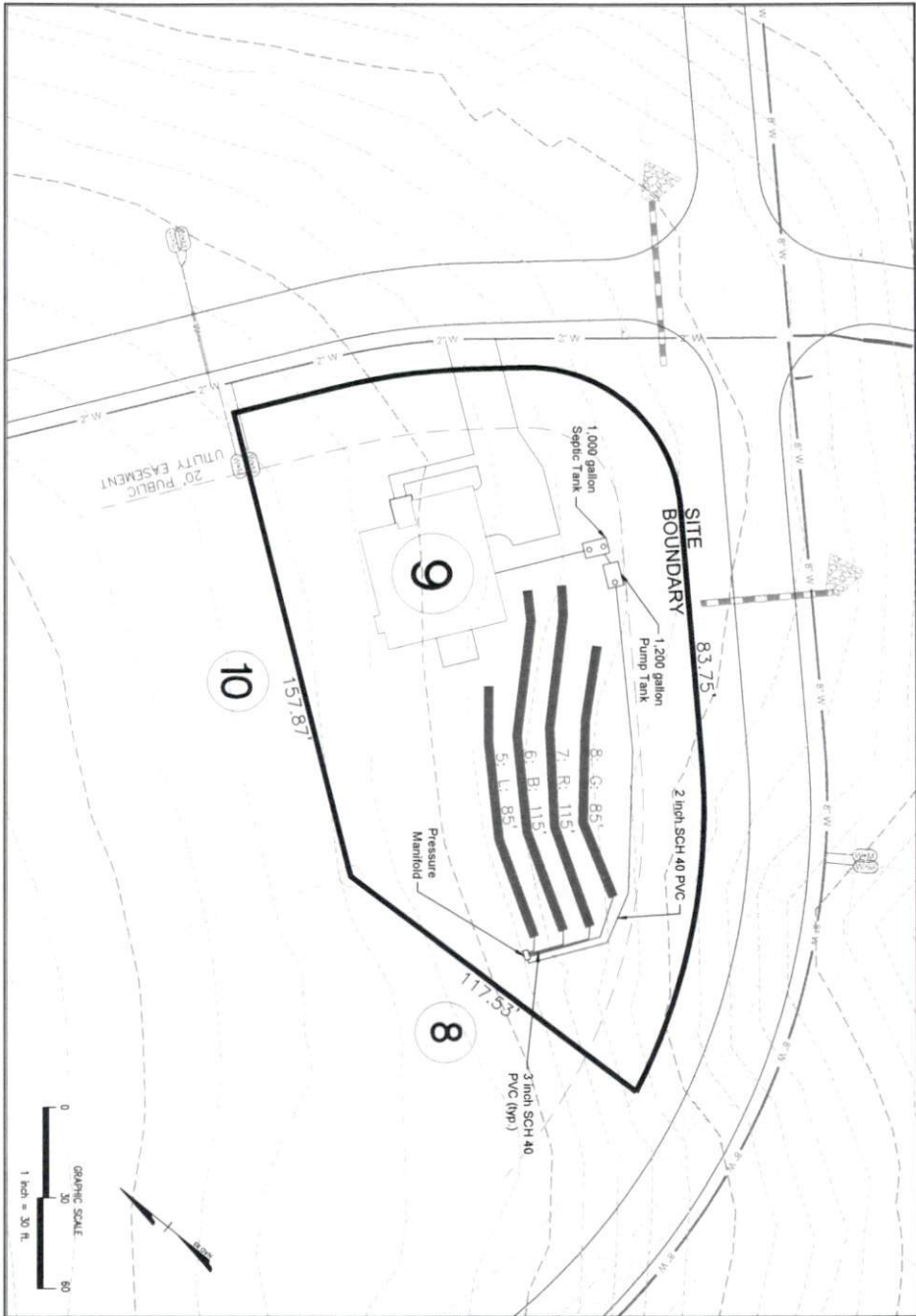

MITCHELL ENVIRONMENTAL, PA
C-2911

1501 LAKESTONE VILLAGE LANE
SUITE 205
FUQUAY VARINA, NC 27526

PREPARED FOR: DonAllen Homes
330 James Rector Road
Huntville, AL 35884

DATE: October 12, 2021

ENGINEER AND SEAL SCIENTIST CONTACT:
SCOTT MITCHELL, PE, LIS

DRAWN BY:
ADAM AYDICK, EI

REVISION NO.	DATE
Original Submitted	October 12, 2021
Revision 1	-----
Revision 2	-----
Revision 3	-----
Water Set	-----

SHEET NUMBER
2 of 7
Prince Place Lot 9 Initial Nit/Nitrogen Field

Repair System

PRESSURE MANIFOLD DESIGN

Name: Davidson Homes P.I.N. #: 0633-76-7692 D #: N/A
 Address: Prince Place Drive Subdiv: Prince Place Lot#: 9
 # of BDR: 4 Daily Flow: 480 gal/day L.T.A.R.: 0.300 gal/day/sq.ft
 Septic Tank: 1000 gals (min.) Pump Tank: 1200 gals (min.) Sq. Foot: 1200 Stone Depth: N/A
 Number of Taps: 4 Length of Trenches: Varies ft(See Tap Chart for Details) (EZ Flow)
 Depth of Trenches: see Harnett County Permit Manifold Length: 42 in
 Manifold Diameter: 3in sch 80pvc (minimum) Tap Configuration: 6 in spacing 1 side(s) of manifold
 Supply Line: length: 200 ft Diameter: 2 in sch 40pvc
 Friction Loss + Fitting Loss: 4.08 ft(supply line length + 70' for fittings in pump tank)
 Design Head: 2.0 ft Elevation Head: 11.07 ft
 Vent Hole Size: 3/16 in Orifice Coefficient of Discharge: 0.60
 Orifice Coefficient of Contraction: 0.62 Orifice Coefficient of Velocity: 0.97
 Maximum Head Supplied by Selected Pump(s) at Total Design Flowrate: 22 ft
 Orifice / Vent Hole Flowrate: 1.94 gpm Head Loss at Orifice / Vent Hole: 1.40 ft
 Total Head: 18.54 ft Pump to Deliver: 27.12 gals/min at 18.54 ft head
 Dosing Volume: 171.60 gals.
 Drawdown: 171.60 gals divided by 19 gals/in = 9.03 inches

SJE Rhombus Installer Friendly Series simplex control panel, or equivalent, required
 A septic tank filter, or equal is required.
 Possible pumps: Hydromatic: Goulds: Myers:
 Zoeller: 137 Other:

TAP CHART

Bench Mark	<u>5.03</u>	is = 100.00	set at	<u>Top EIR 9/10 rear corner</u>	Design Head:	<u>2.0</u>			
Pump tank elev.	<u>10.6</u>	<u>94.43</u>	Pump elev.	<u>89.43</u>	Manifold elev.	<u>100.50</u>			
line	color	rod read	Elevation	length	hole size	flow/tap	gal/day	trench area	LINE LTAR
1	Orange	5.53	99.50	115	1/2in SCH 40	7.11	135.54	345	0.3929
2	Green	6.15	98.88	115	1/2in SCH 40	7.11	135.54	345	0.3929
3	Yellow	6.75	98.28	85	1/2in SCH 80	5.48	104.46	255	0.4097
4	Red	7.36	97.67	85	1/2in SCH 80	5.48	104.46	255	0.4097
		total	feet =	<u>400</u>	gal/min =	<u>25.2</u>	LTAR =		<u>0.3000</u>
% of Pipe Vol.	<u>66</u>			Des. Flow	480.00			(Itar + 5%)	0.3150
Dose Volume	171.60			Pump Run=	19.06			(Itar W/ INOV)	0.4000
Dose Pump Time	6.81			Tank Gal/IN	19			(Itar + 5%)	0.4200
Drawdown in Inches	9.03			Elev. Head	11.07				
Supply Line Length	200								
Comments:									

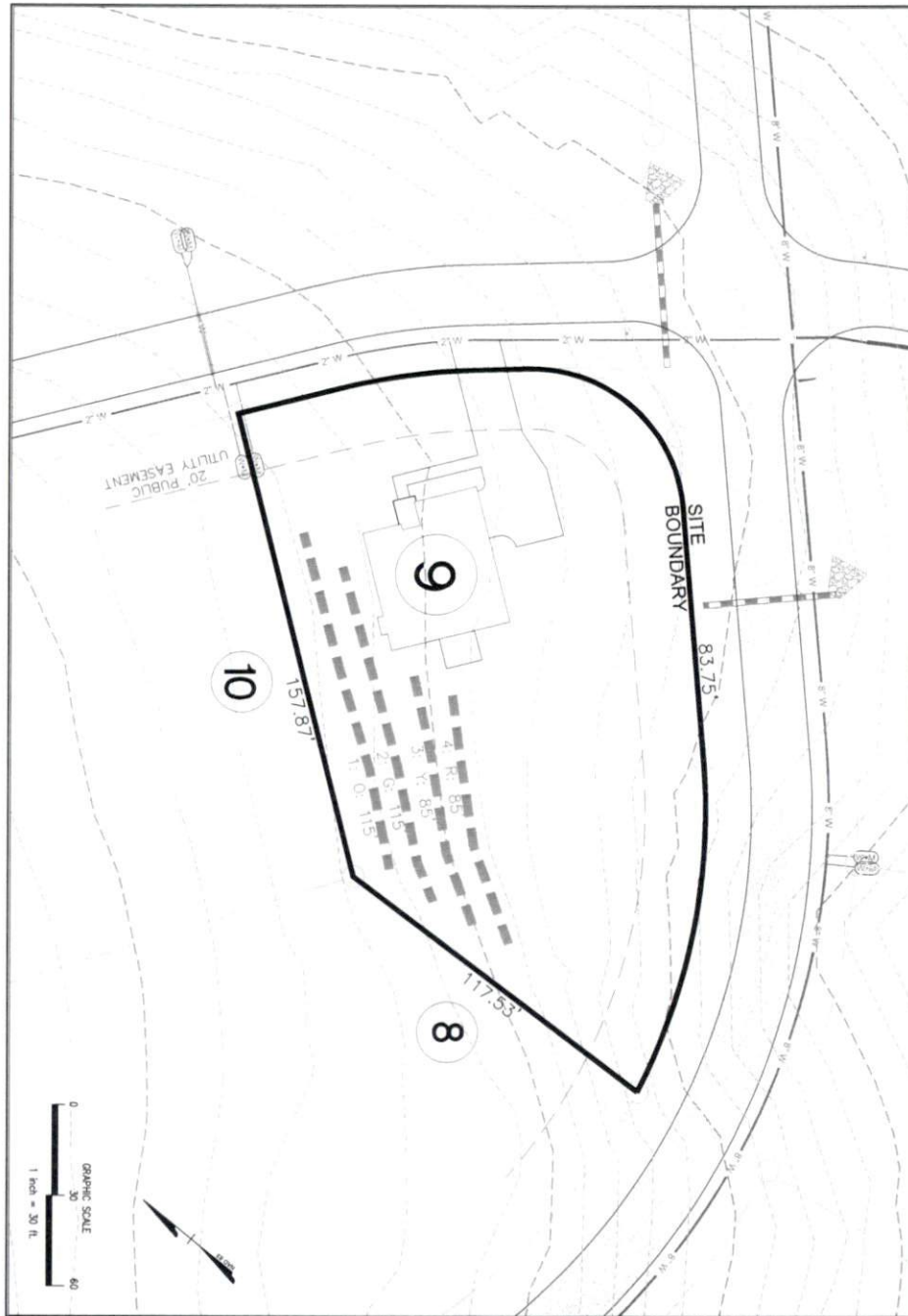

	MITCHELL ENVIRONMENTAL, PA C-2911		PREPARED FOR: Oaklawn Homes 336 James Record Road Huntsville, AL 35824	REVISION NO. Original Submitted	DATE October 12, 2021	SHEET NUMBER	
	1501 LAKESTONE VILLAGE LANE SUITE 205 FUQUAY VARINA, NC 27526		DATE: October 12, 2021	Revision 1 Revision 2 Revision 3	----- ----- -----	3 of 7	
	ENGINEER AND SURVEYOR CONTACT: SCOTT MITCHELL, P.E., L.S.		DRAWN BY: ADAM AYCOCK, D	Master Set	----- -----	----- -----	Prince Place Lot 9 Repair Nitrification Field

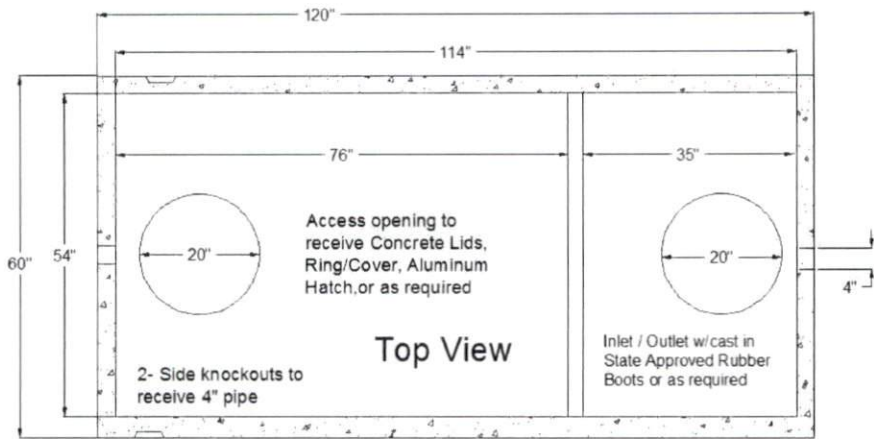

STB - 345 - Top Seam

Approval Date: 12 - 09 - 99

Liquid Capacity 1007 Gallons

Non Traffic Rated

Reinforcing Schedule: # 3 Grade 60 Rebar

4500 PSI Concrete w/ State Approved Structural Fiber

Est. Weight: 8,200 lbs.

Manufactured By:

GARNERS
Septic Tanks, Inc.

Eddie Garner, President
919-718-5181

121 Stanton Hill Road
Carthage, NC 28327 Fax 919-775-2229
Eddie@garnersseptictanks.com

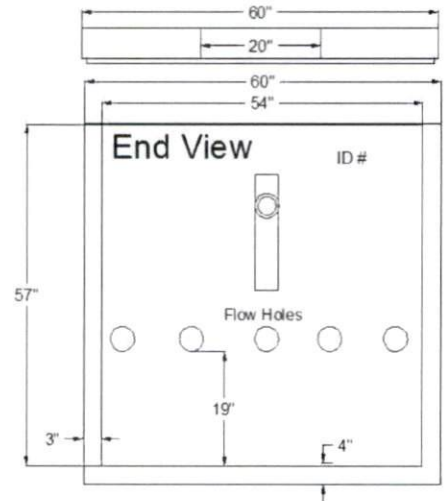
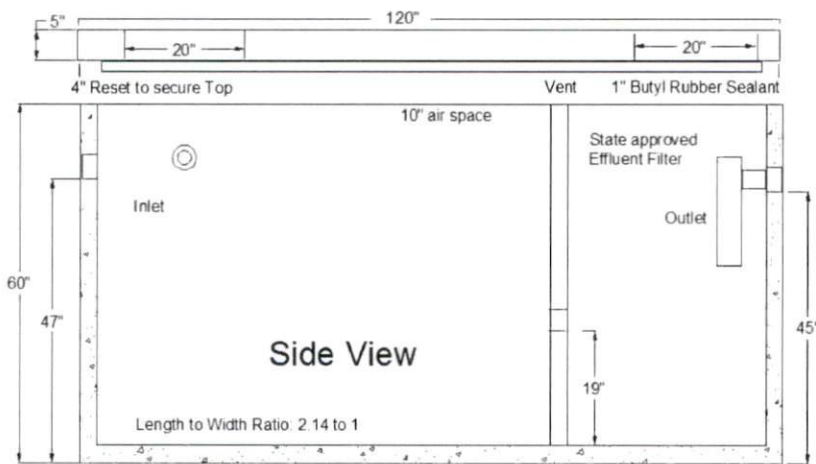



PL-68 Filter and Tee

PL-68 is much more than just an effluent filter. The housing can also be used as an inlet baffle (tee) or an outlet baffle. The housing is designed to accept Polylok's snap in gas deflector to deflect gas bubbles away from the tee and to keep the solids in the tank.

Features:

- Offers 68 linear feet of 1/16" filter slots, which significantly extends time between cleaning.
- Accepts 3/4" PVC handle.
- Locks in any 360° position when used with PL-68 Tee.
- PL-68 Housing can be used as an inlet or outlet tee.
- Gasket prevents bypass.

PL-68 Installation:

Ideal for residential waste flows up to 800 gallons per day (GPD). Easily installs in any new or existing 4" outlet tee.

1. Locate the outlet of the septic tank.
2. Remove the tank cover and pump tank if necessary.
3. Glue the filter housing to the outlet pipe, or use a Polylok Extend & Lok if not enough pipe exists.
4. Insert the PL-68 filter into tee.
5. Replace and secure the septic tank cover.

PL-68 Maintenance:

The PL-68 Effluent Filter will operate efficiently for several years under normal conditions before requiring cleaning. It is recommended that the filter be cleaned every time the tank is pumped, or at least every three years.

1. Do not use plumbing when filter is removed.
2. Pull PL-68 out of the tee.
3. Hose off filter over the septic tank. Make sure all solids fall back into septic tank.
4. Insert filter back into tee/housing.

Related Products:

PL-68 Filter Concrete Baffle
 Extend & Lok™

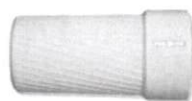

Extend & Lok™
 Easily installs into existing tanks.



Spacer Bushing
 4" SCHD 40 to SDR 35



Spacer Bushing
 4" SCHD 40 to 110mm Pipe



2" Extender

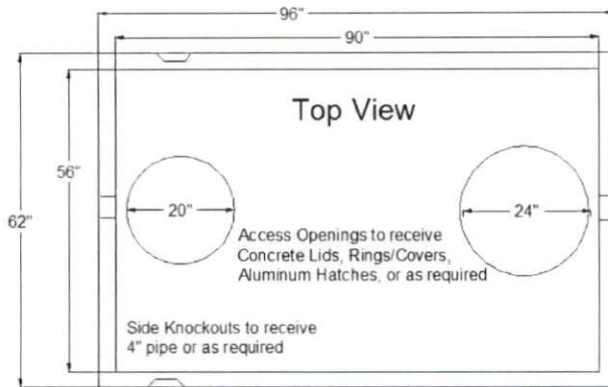

PT - 213 Top seam

Date: 08-18-93

Non Traffic Rated

Liquid Capacity 1,211 Gallons

Reinforcing Schedule: # 3 Grade 60 Rebar

4500 PSI Concrete w/ State Approved Structural Fiber

2.5 yds. Est. Weight 8,900 lbs. 19 gals per in.

Manufactured By:

GARNERS

Septic Tanks, Inc.

Eddie Garner, President

919-718-5181

121 Stanton Hill Road

Carthage, NC 28327

Fax 919-775-2229

Eddie@garnersseptic tanks.com

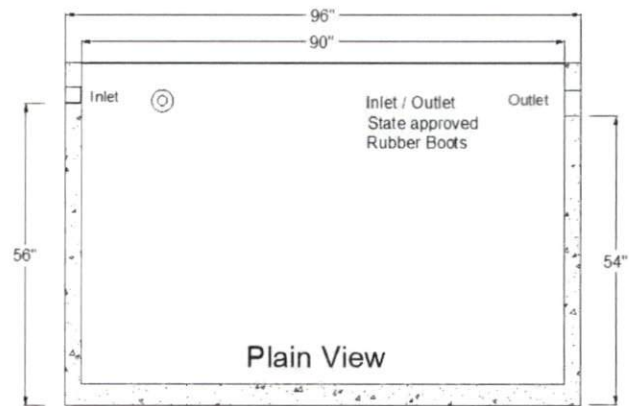
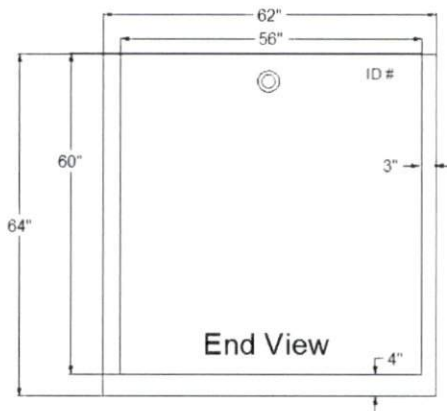
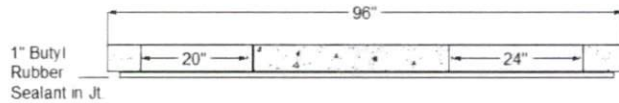
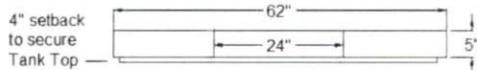

INSTALLER FRIENDLY SERIES® - IFS Single Phase Simplex (Demand/TD)

Single phase, simplex demand dose or timed dose, float controlled system for pump control and system monitoring.

The IFS simplex control panel is designed to control one 120, 208, 240 VAC single phase pump in water and sewage installations.

The IFS control panel features an easy-to-use touch pad with display on the inner door for programming and system monitoring.

The panel configuration can be easily converted in the field to either a timed dose or demand dose.

TOUCH PAD FEATURES

- A. **Float Indicators** illuminate when floats are activated. Alarm will activate if a float operates out of sequence.
- B. **HOA (Hand-Off-Automatic) Buttons** control pump mode with indication. Hand mode defaults to Automatic when stop level or redundant off level is reached.
- C. **Pump Run Indicator** illuminates when pump is called to run.
- D. **LED Display** shows system information including: mode, pump elapsed time (hh:mm), events (cycles), alarm counter, float error count, timed dose override counter (timed dose only), and ON/OFF times (timed dose only).
- E. **NEXT Push Button** toggles display.
- F. **UP and SET Push Buttons** set pump ON/OFF times (timed dose only).

PANEL COMPONENTS

1. **Enclosure** base measures 10 X 8 X 4 inches (25.4 X 20.32 X 10.16 cm). NEMA 4X (ultraviolet stabilized thermoplastic with removable mounting feet for outdoor or indoor use). **Note:** Options, voltage, and amp range selected may change enclosure size and component layout.
2. **Red Alarm Beacon** provides 360° visual check of alarm condition.
3. **Exterior Alarm Test/Normal/Silence Switch** allows horn and light to be tested and horn to be silenced in an alarm condition. Alarm automatically resets once alarm condition is cleared.
4. **Alarm Horn** provides audio warning of alarm condition (83 to 85 decibel rating).
5. **Circuit Breaker** (optional) provides pump disconnect and branch circuit protection.
6. **Power Relay** controls pump by switching electrical lines. Definite purpose contactor used when pump full load amps are above 15.
7. **Float Connection Terminal Block**
8. **Incoming Control/Alarm Power & Pump Terminal Block**
9. **Control Power Indicator/Fuse** indicator light illuminates if control power is present in panel. Alarm will activate if control fuse is blown.
10. **Alarm Power Indicator/Fuse** indicator light illuminates if alarm power is present in panel.
11. **Ground Lug**

NOTE: Schematic/Wiring Diagram and Pump Specification Label are located inside the panel on enclosure cover

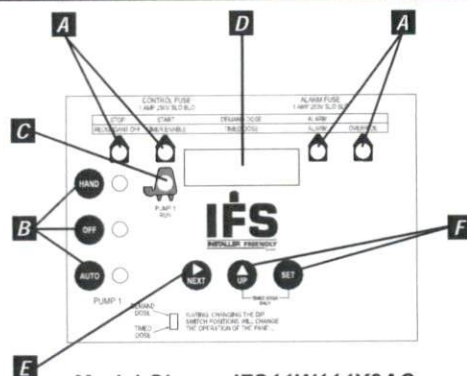

Model Shown IFS11W114X8AC
(Inner door view)

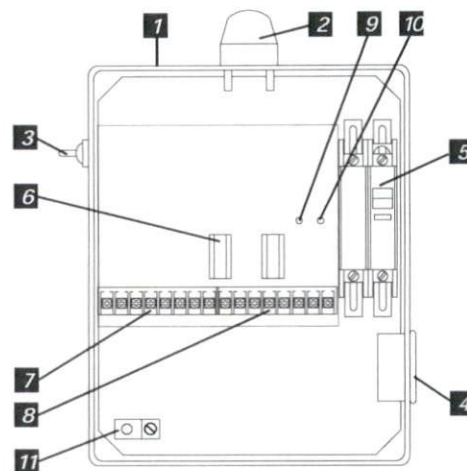

Model Shown IFS11W114X8AC
(Inside view)

Reg. Cdn Pat. & TM Off

FEATURES

- Entire control system (panel and switches) is UL Listed to meet and/or exceed industry safety standards
- Dual safety certification for the United States and Canada
- Standard package includes:
 - Demand Dose** - three 20' SJE MilliAmpMaster™ control switches
 - Timed Dose** - two 20' SJE MilliAmpMaster™ control switches
- Complete with step-by-step installation instructions
- Three-year limited warranty



SJE Rhombus

PO Box 1708, Detroit Lakes, MN 56502

1-888-DIAL-SJE • 1-218-847-1317

1-218-847-4617 Fax

email: sje@sjerhombus.com

www.sjerhombus.com

SEE BACKSIDE FOR COMPLETE LISTING OF AVAILABLE OPTIONS.

IFS 2 1 W Note Note 4 H 8AC, 10E, 10F 15A

MODEL IFS

MODEL TYPE

- 1 = SPLX TIMED DOSE (includes option 8AC standard)
- 2 = SPLX DEMAND DOSE (includes option 8AC standard)

ALARM PACKAGE

- 1 = alarm package (includes test/normal/silence switch, fuse, red light & horn)

ENCLOSURE RATING

- W = NEMA 4X

STARTING DEVICE

- 1 = 120/208/240 VAC
- 9 = 120 VAC

PUMP FULL LOAD AMPS

- 0 = 0-7 FLA
- 1 = 7-15 FLA
- 2 = 15-20 FLA

PUMP DISCONNECTS

- 0 = no pump disconnect
 - 4 = circuit breaker
- 120 VAC (must select starting device option 9)
120/208/240 VAC (must select starting device option 1)

SWITCH APPLICATIONS

- H = floats (Timed dose = low level and alarm / Demand dose = stop, start, and alarm) (select 17 option)
 - X = no float
- timed dose
demand Dose

Note: Pump down applications only.

OPTIONS *Listed below*

Note: Starting device, pump full load amps, cord length, and float type to be selected by installer and their electrician upon selection of pump.

If additional features are required, call the factory for a quote on an Engineered Custom control panel.

- CODE DESCRIPTION**
- 1J Duo alarm inputs
 - 3A Alarm flasher
 - 3B Manual reset alarm
 - 4A Redundant off (select option 4D if floats are required)
Demand Dose
Timed Dose
 - 4D Redundant off float
 - 6A Auxiliary alarm contacts, form C
 - 8AC Display board includes: ETM counter, events (cycles) counter, alarm counter, and override counter (timed dose only). **(Included as standard.)**
 - 10E Lockable latch - NEMA 4X
 - 10F Lightning arrestor (must select pump circuit breaker, control and alarm power combined)
 - 10K Anti-condensation heater
 - 11C NEMA 1 remote alarm panel
(must select option 6A)

- CODE DESCRIPTION**
- 11D NEMA 4X remote alarm panel
(must select option 6A)
 - 15A Control / Alarm circuit breaker
 - 16A 10' cord in lieu of 20' (per float)
 - 16B 15' cord in lieu of 20' (per float)
 - 16C 30' cord in lieu of 20' (per float)
 - 16D 40' cord in lieu of 20' (per float)
 - 17C Sensor Float® / internally weighted ▲ (per float)
 - 17D Sensor Float® / externally weighted ▲ (per float)
 - 17G MilliAmpMaster™/ pipe clamp ● (per float)
 - 17H MilliAmpMaster™/ externally weighted ● (per float)
 - 17J Sensor Float® / pipe clamp ▲ (per float)
 - 18A Timer override option with float (timed dose only)
- Mechanically-activated ▲ Mercury-activated

SAMPLE

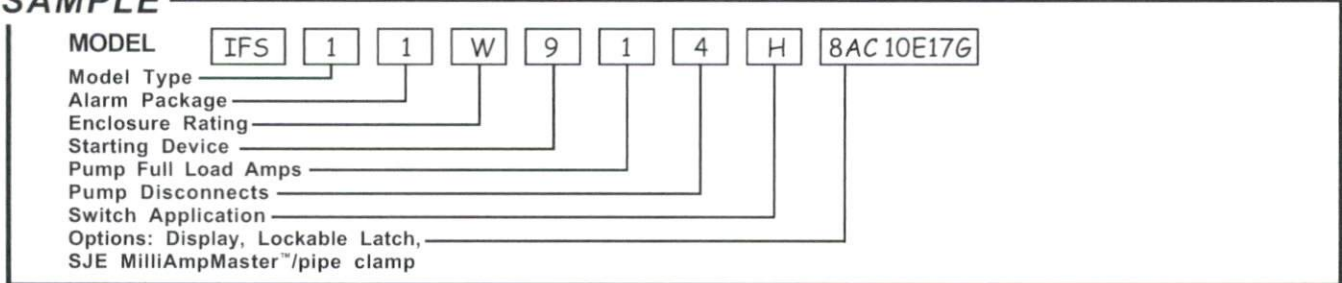

Product information presented here reflects conditions at time of publication. Consult factory regarding discrepancies or inconsistencies.



TECHNICAL DATA SHEET FLOW-MATE SERIES *Models 137, 139 Effluent / Dewatering Pumps*

PRODUCT SPECIFICATIONS

MOTOR	Horse Power	1/2
	Voltage	115 - 460
	Phase	1 or 3 Ph
	Hertz	60 Hz
	RPM	1750
	Type	Split phase or 3 phase
	Insulation	Class B
	Amps	1.4 - 10.7
PUMP	Operation	Automatic or nonautomatic
	Auto On/Off Points	10" (25.4 cm) / 2-3/4" (7 cm)
	Discharge Size	1-1/2" NPT
	Solids Handling	5/8" (15 mm) spherical solids
	Cord Length	10' (3 m) automatic, 15' (5 m) nonautomatic
	Cord Type	UL listed, neoprene cord
	Max. Head	26' (8 m)
	Max. Flow Rate	93 GPM (352 LPM)
	Max. Operating Temp.	130° F (54° C) [extra duty 140°F (60°C)]
	Cooling	Oil filled
	Motor Protection	Auto reset thermal overload (1 Ph)
MATERIALS	Motor Housing	Cast iron (137) or bronze (139)
	Pump Housing	Cast iron (137) or bronze (139)
	Base	Cast iron (137) or bronze (139)
	Upper Bearing	Sleeve bearing
	Lower Bearing	Sleeve bearing
	Mechanical Seals	Carbon and ceramic
	Impeller Type	Non-clogging vortex
	Impeller	Cast iron or bronze
	Hardware	Stainless steel
	Motor Shaft	AISI 1215 cold rolled steel
	Gasket	Neoprene

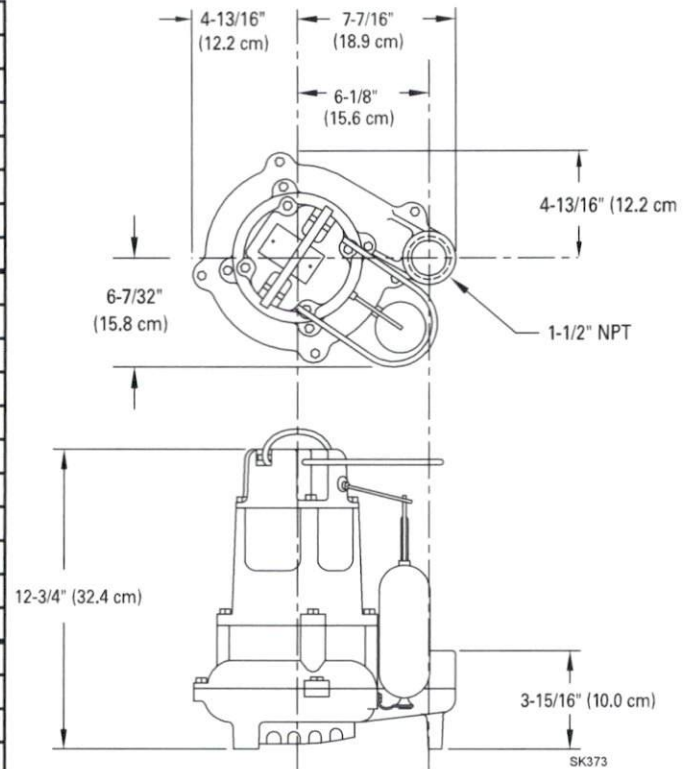

NOTE: See model comparison chart for specific details.



TOTAL DYNAMIC HEAD FLOW PER MINUTE

MODEL		137/139	
Feet	Meters	Gal.	Liters
5	1.5	90	340
10	3.0	75	284
15	4.6	58	220
20	6.1	36	136
25	7.6	8	30
Shut-off Head:		26 ft. (8.0m)	

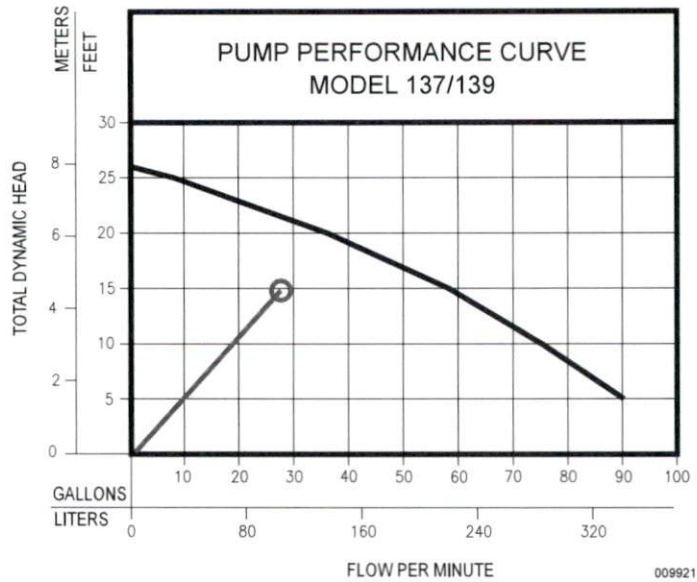

009921

Model	MODEL COMPARISON											CERTIFICATIONS	
	Seal	Mode	Volts	Ph	Amps	HP	Hz	Lbs	Kg	Simplex	Duplex	CSA	UL
M137	Single	Auto	115	1	10.7	1/2	60	47	21	1	4	Y	Y
N137	Single	Non	115	1	10.7	1/2	60	46	21	2 or 3	2 or 4	Y	Y
BN137	Single	Auto	115	1	10.7	1/2	60	48	22	**	4	Y	Y
D137	Single	Auto	230	1	5.8	1/2	60	47	21	1	4	Y	Y
E137	Single	Non	230	1	5.8	1/2	60	48	22	2 or 3	4	Y	Y
*H137	Single	Auto	200	1	6.2	1/2	60	48	22	1	4	Y	N
*I137	Single	Non	200	1	6.2	1/2	60	48	22	3	4	Y	N
*J137	Single	Non	200	3	2.6	1/2	60	46	21	3	4	Y	Y
*F137	Single	Non	230	3	2.6	1/2	60	48	22	3	4	Y	Y
*G137	Single	Non	460	3	1.4	1/2	60	48	22	3	4	N	N
BE137	Single	Auto	230	1	5.8	1/2	60	48	22	**	---	Y	Y
M139	Single	Auto	115	1	10.7	1/2	60	51	23	1	4	Y	Y
N139	Single	Non	115	1	10.7	1/2	60	51	23	2 or 3	2 or 4	Y	Y
D139	Single	Auto	230	1	5.8	1/2	60	47	21	1	4	Y	Y
E139	Single	Non	230	1	5.8	1/2	60	48	22	2 or 3	4	Y	Y
*H139	Single	Auto	200	1	6.2	1/2	60	48	22	1	4	Y	N
*I139	Single	Non	200	1	6.2	1/2	60	48	22	3	4	Y	N
*J139	Single	Non	200	3	2.6	1/2	60	50	23	3	4	Y	Y
*F139	Single	Non	230	3	2.6	1/2	60	48	22	3	4	Y	Y
*G139	Single	Non	460	3	1.4	1/2	60	48	22	3	4	N	N

* No molded plug ** Single piggyback switch included BE and BN models include a piggyback variable level pump switch.

SELECTION GUIDE

1. Integral float-operated mechanical switch, no external control required.
2. For automatic, use single piggyback variable level float switch or double piggyback variable level float switch. Refer to FM0477.
3. See FM1228 for correct model of simplex control panel.
4. See FM0712 for correct model of duplex control panel or FM1663 for a residential alternator system.

CAUTION All installation of controls, protection devices and wiring should be done by a qualified licensed electrician. All electrical and safety codes should be followed including the most recent National Electrical Code (NEC) and the Occupational Safety and Health Act (OSHA).



GEOSYNTHETIC AGGREGATE TECHNOLOGY

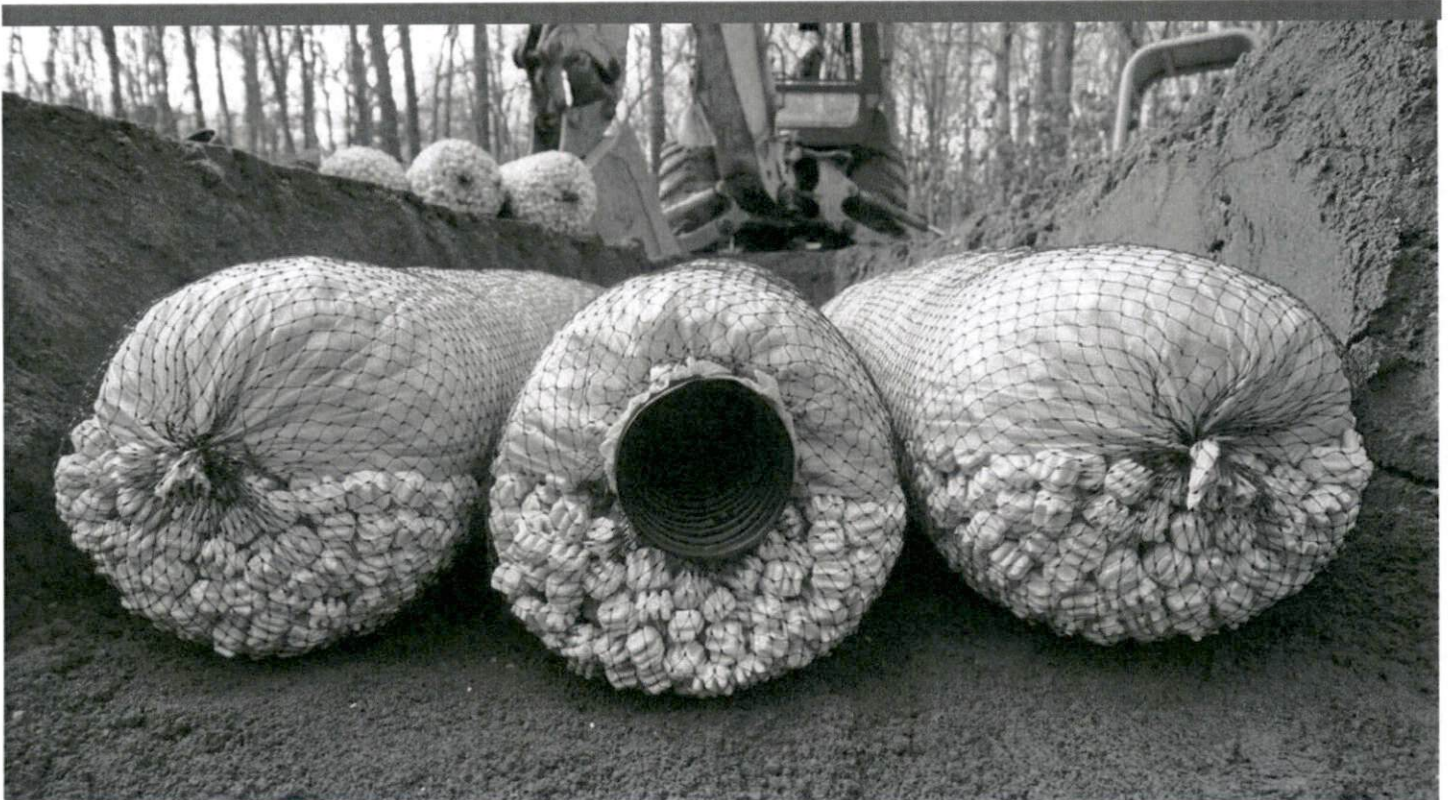

EZflow by Infiltrator is an environmentally friendly replacement to traditional stone and pipe drainfields using an engineered geosynthetic aggregate modular design. The EZflow system is designed to improve infiltration performance by eliminating the fines associated with crushed stone, and reducing compaction and embedment associated with stone. Preassembled units include a 3" or 4" perforated pipe surrounded by aggregate and held in place with a durable high-strength netting. This product comes in easy-to-contour 5' and 10' lengths and in diameters of 7, 8, 9, 10, 12, 13, or 14 inches.

Lightweight expanded polystyrene

construction offers structural integrity and resists compaction. Engineered flow-channels increase void space creating improved water flow and greater storage.



INFILTRATOR
water technologies

Compared with stone and pipe, benefits include:

- Always clean and free of fines
- Bundles are quick to install, saving costs on heavy machinery and labor
- Modular construction allows configurations to match trench dimensions for most system shapes and sizes
- Engineered for optimal storage and absorption efficiencies
- Ability to contour along sloped sites and around trees or landscaping
- Lightweight system is perfect for repairs and tight job sites
- Easily hand-carried into position reducing time and labor
- 5' or 10' lengths with simple snap, internal couplers
- Easier cleanup at the job site with the elimination of stone
- Manufactured from recycled materials rather than a mined natural resource
- A wide variety of diameters and configurations to meet any installation professional's needs
- Approved in many jurisdictions with an increased efficiency rating, reducing drainfield size
- Backed by the leader in the onsite wastewater industry

Bundle System Configurations: Available in 7", 8", 9", 10", 12", 13" and 14" diameter bundles.

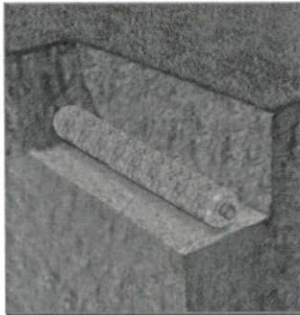

Single Bundle

0701P-GEO 1201P-GEO
0801P-GEO 1401P-GEO
1201P-GEO 1801P-GEO
1001P-GEO

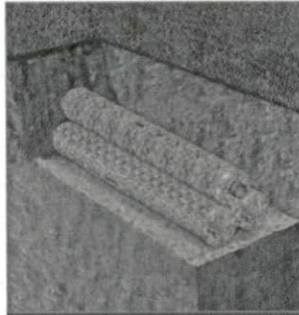

Triangular Bundle

1003T-GEO 1303T-GEO
1203T-GEO 1403T-GEO

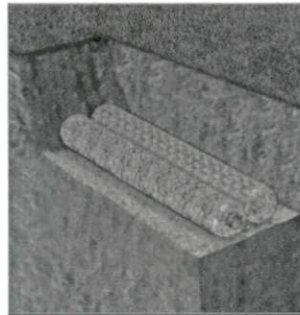

Horizontal Bundles

0705H-GEO 1303H-GEO
0904H-GEO 1202H-GEO
1002H-GEO 1203H-GEO

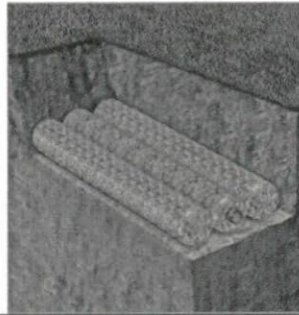

1206H-GEO 1402H-GEO
1303H-GEO 1802H-GEO

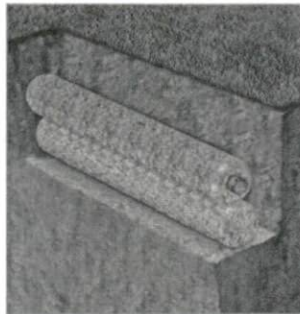

Vertical Bundles

1002V-GEO 1006V-GEO 1203V-GEO 1206V-GEO
1003V-GEO 1202V-GEO 1204V-GEO 1402V-GEO
1004V-GEO

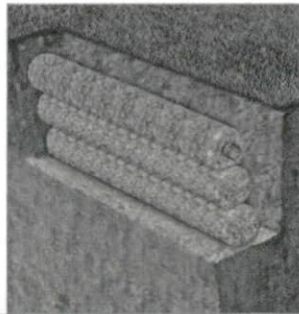

Notes:

1. Other systems include 10" and 12" bed systems. Bed size will dictate the number of bundles.
2. System dimensions are dependent upon bundle diameter and configuration.
3. LLP is for "Low Pressure Pipe" in which a pressurized distribution pipe is field installed within the corrugated pipe.
4. Internal pipe and couplings meet the requirements of ASTM F405.
5. Bundles are also available without geotextile between the netting and synthetic aggregate.

INFILTRATOR WATER TECHNOLOGIES STANDARD LIMITED WARRANTY

(a) The structural integrity of each EZflow by Infiltrator expanded polystyrene drainfield system and other accessories manufactured by EZflow by Infiltrator ("Units"), when installed and operated in a leachfield of an onsite septic system in accordance with Infiltrator's instructions, is warranted to the original purchaser ("Holder") against defective materials and workmanship for one year from the date that the septic permit is issued for the septic system containing the Units; provided, however, that if a septic permit is not required by applicable law, the warranty period will begin upon the date that installation of the septic system commences. To exercise its warranty rights, Holder must notify Infiltrator in writing at its Corporate Headquarters in Old Saybrook, Connecticut within fifteen (15) days of the alleged defect. Infiltrator will supply replacement Units for Units determined by EZflow by Infiltrator to be covered by this Limited Warranty. EZflow by Infiltrator's liability specifically excludes the cost of removal and/or installation of the Units.

(b) THE LIMITED WARRANTY AND REMEDIES IN SUBPARAGRAPH (a) ARE EXCLUSIVE. THERE ARE NO OTHER WARRANTIES WITH RESPECT TO THE UNITS, INCLUDING NO IMPLIED WARRANTIES OF MERCHANTABILITY OR FITNESS FOR A PARTICULAR PURPOSE

(c) This Limited Warranty shall be void if any part of the EZflow system is manufactured by anyone other than EZflow by Infiltrator. The Limited Warranty does not extend to incidental, consequential, special or indirect damages. Infiltrator shall not be liable for penalties or liquidated damages, including loss of production and profits, labor and materials, overhead costs, or other losses or expenses incurred by the Holder or any third party. Specifically excluded from Limited Warranty coverage are damage to the Units due to ordinary wear and tear, alteration, accident, misuse, abuse or neglect of the Units; the Units being subjected to vehicle traffic or other conditions which are not permitted by the installation instructions; failure to maintain the minimum ground covers set forth in the installation instructions; the placement of improper materials into the system containing the Units; failure of the Units or the septic system due to improper siting or improper sizing, excessive water usage, improper grease disposal, or improper operation; or any other event not caused by Infiltrator. This Limited Warranty shall be void if the Holder fails to comply with all of the terms set forth in this Limited Warranty. Further, in no event shall Infiltrator be responsible for any loss or damage to the Holder, the Units, or any third party resulting from installation or shipment, or from any product liability claims of Holder or any third party. For this Limited Warranty to apply, the Units must be installed in accordance with all site conditions required by state and local codes; all other applicable laws; and Infiltrator's installation instructions.

(d) No representative of Infiltrator has the authority to change or extend this Limited Warranty. No warranty applies to any party other than the original Holder.

The above represents the Standard Limited Warranty offered by Infiltrator. A limited number of states and counties have different warranty requirements. Any purchaser of Units should contact Infiltrator's Corporate Headquarters in Old Saybrook, Connecticut, prior to such purchase, to obtain a copy of the applicable warranty, and should carefully read that warranty prior to the purchase of Units.



4 Business Park Road
P.O. Box 768
Old Saybrook, CT 06475
860-577-7000 • Fax 860-577-7001
1-800-221-4436
www.infiltratorwater.com

U.S. Patents: 4,759,661; 5,017,041; 5,156,488; 5,336,017; 5,401,116; 5,401,459; 5,511,903; 5,716,163; 5,588,778; 5,839,844 Canadian Patents: 1,329,959; 2,004,564 Other patents pending. Infiltrator, Equalizer, Quick4, and SideWinder are registered trademarks of Infiltrator Water Technologies. Infiltrator is a registered trademark in France. Infiltrator Water Technologies is a registered trademark in Mexico. Contour, MicroLeaching, PolyTuff, ChamberSpacer, MultiPort, PosiLock, QuickCut, QuickPlay, SnapLock and StraightLock are trademarks of Infiltrator Water Technologies. PolyLok is a trademark of PolyLok, Inc. TUF-TITE is a registered trademark of TUF-TITE, INC. Ultra-Rib is a trademark of IPEX Inc.

© 2015 Infiltrator Water Technologies, LLC. All rights reserved. Printed in U.S.A.

EZ01 0315AG

Contact Infiltrator Water Technologies' Technical Services Department for assistance at 1-800-221-4436

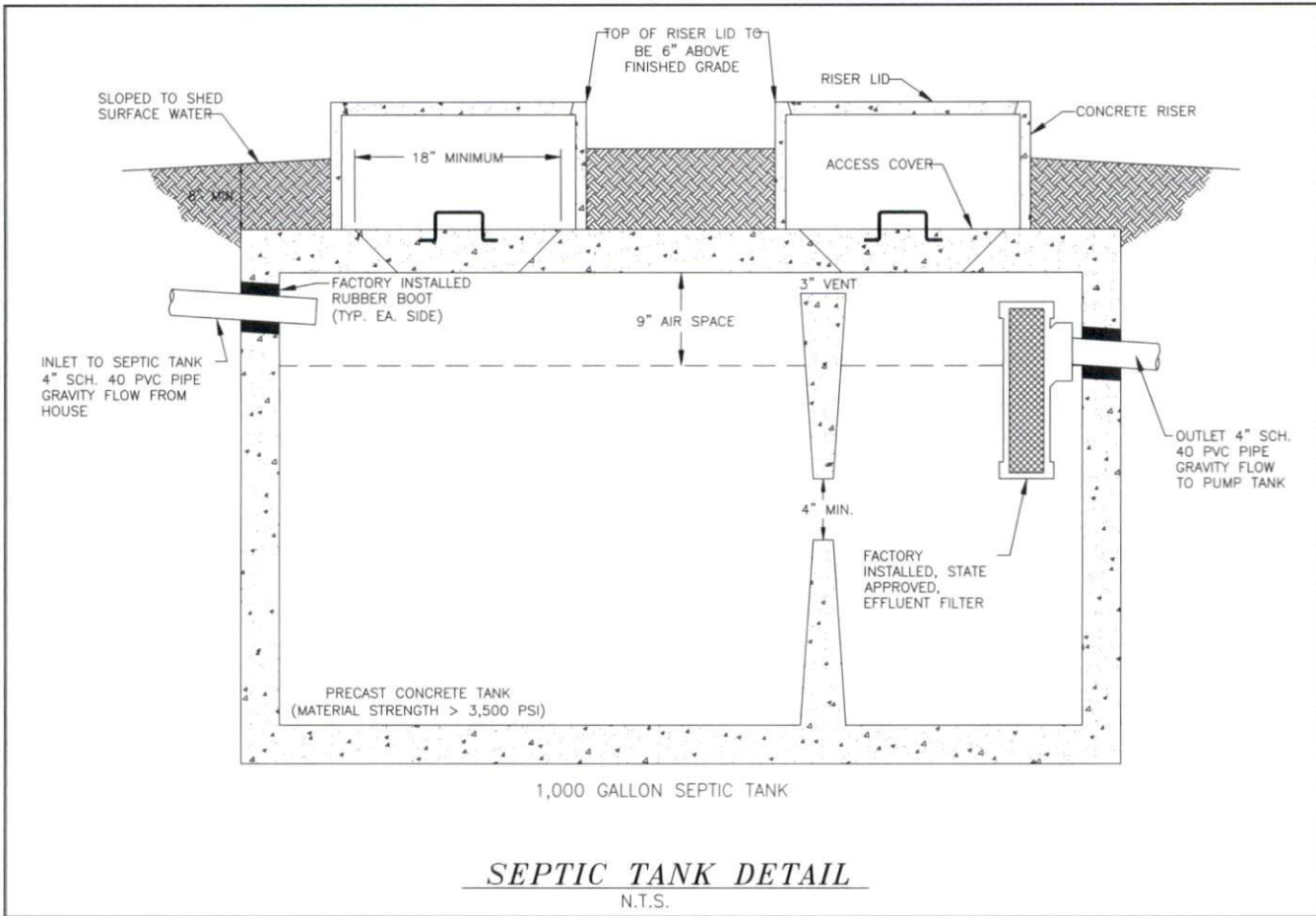

REVISION NO. Original Submitted		DATE October 12, 2007	SHEET NUMBER 4 of 7
Revision 1 Revision 2 Revision 3 Master Set	DESIGNER Scott Mitchell, P.E., L.S. DATE October 12, 2007 ENGINEER AND SEAL Scott Mitchell, P.E., L.S.	PROJECT 1501 LAKESTONE VILLAGE LANE SUITE 208 PUQUAY VARINA, NC 27526	PROJECT NAME Septic Tank Detail
APPROVED FOR Mitchell Environmental, PA C-2811		DATE October 12, 2007	PROJECT NAME Septic Tank Detail

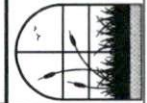

PRESSURE MANIFOLD DETAIL
FOR PRINCE PLACE LOT 9 INITIAL SEPTIC SYSTEM
 N.T.S.

NOTE: MANIFOLD MAY NEED TO BE FLIPPED SO THAT SUPPLY LINE ENTRANCE AND CLEANOUTS ARE REVERSED. SEE SITE PLAN.
 NOTE: THE NUMBER OF TAPS MAY VARY FROM LOT TO LOT. SEE DESIGN SHEET FOR NUMBER OF TAPS.

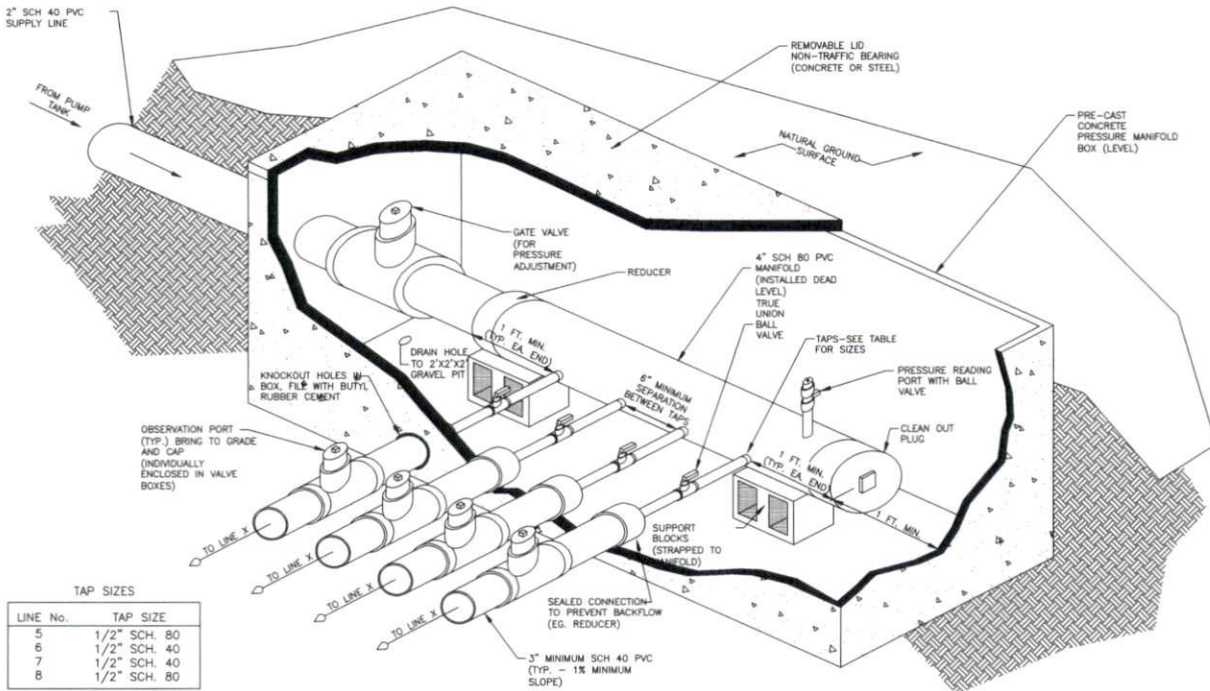

TAP SIZES

LINE No.	TAP SIZE
5	1/2" SCH. 80
6	1/2" SCH. 40
7	1/2" SCH. 40
8	1/2" SCH. 80

REVISION NO.	DATE	SHEET NUMBER
Original Submitted	October 12, 2021	6 of 7
Revision 1		Prince Place
Revision 2		Lot 9
Revision 3		Pressure Manifold Detail
Master Set		
PREPARED BY: Mitchell Environmental, PA Deshawn Thomas 1500 Northchase Blvd Nashville, TN 37205	DATE: October 12, 2021	
ENGINEER AND SEAL (REGISTERED CONTACT): SCOTT MITCHELL, P.E., L.S.	SCALE: AS SHOWN	
MITCHELL ENVIRONMENTAL, PA C-2311 1501 LAKESTONE VILLAGE LANE SUITE 203 FUYUAY VARINA, NC 27526		

NITRIFICATION TRENCH DETAIL FOR EZ-FLOW

N.T.S.

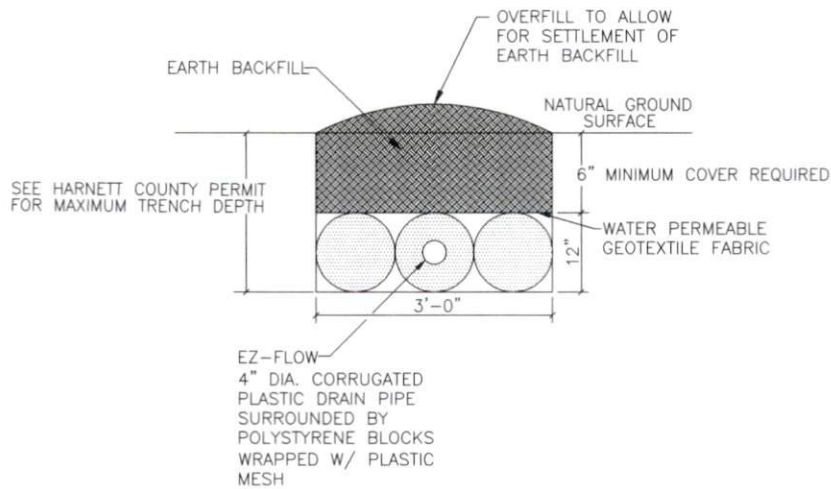

NOTES:

1. PERFORATED CORRUGATED PLASTIC PIPE SHALL MEET REQUIREMENTS OF ASTM D 2729.
2. PIPE SHALL BE LEVEL.
3. ENDCAP SHALL BE PROVIDED AT END OF ALL CORRUGATED PLASTIC PIPE LINES.
4. TRENCH BOTTOM SHALL BE LEVEL.
5. HAND RAKE TRENCH WALLS PRIOR TO PLACEMENT OF TRENCH MEDIA IF SOIL SMEARING IS PRESENT.

<p>REVISION NO. Original Submittal</p> <p>DATE October 12, 2021</p> <p>REVISION 1</p> <p>REVISION 2</p> <p>REVISION 3</p> <p>DATE SET</p>	<p>PROJECT NAME 1501 LAKESTONE VILLAGE LANE SUITE 205 FUQUAY VARINA, NC 27526</p> <p>DATE October 12, 2021</p> <p>DESIGNED AND SEALED BY SCOTT MITCHELL, P.E., L.S.</p> <p>DATE SET Refer to Note 8</p>	<p>SHEET NUMBER 7 of 7</p> <p>PROJECT PLACE Lot 9 French Detail</p>
<p>MITCHELL ENVIRONMENTAL, PA C-2811</p>		