

THE WHITLEY

PROJECT #
DRB2101-0126
DATE
07/01/2021
DESIGNED BY
MMB
CHECKED BY
DRB
SCALE
1/4" = 1'-0"

www.
drbdesign.com

PROJECT NAME
THE
WHITLEY

DRB DESIGN
drbdesign@drbdesign.com 919.631.5979
250 Shipwash Dr Suite 105 Garner, NC 27529

CLIENT NAME
Pleasant Builders of NC, LLC
2201 Sherrif Johnson Rd.
Lillington, NC 27546
919-878-7685
pleasantbuildersnc@gmail.com

SHEET NAME
ELEVATIONS
SHEET #

A1 of 5

NOTE: CONTRACTOR TO PROVIDE ADEQUATE ROOF VENTILATION PER BUILDING CODE

SHAKES AS PER OWNER / BUILDER SELECTION

FIBERGLASS SHINGLES AS PER OWNER / BUILDER SELECTION

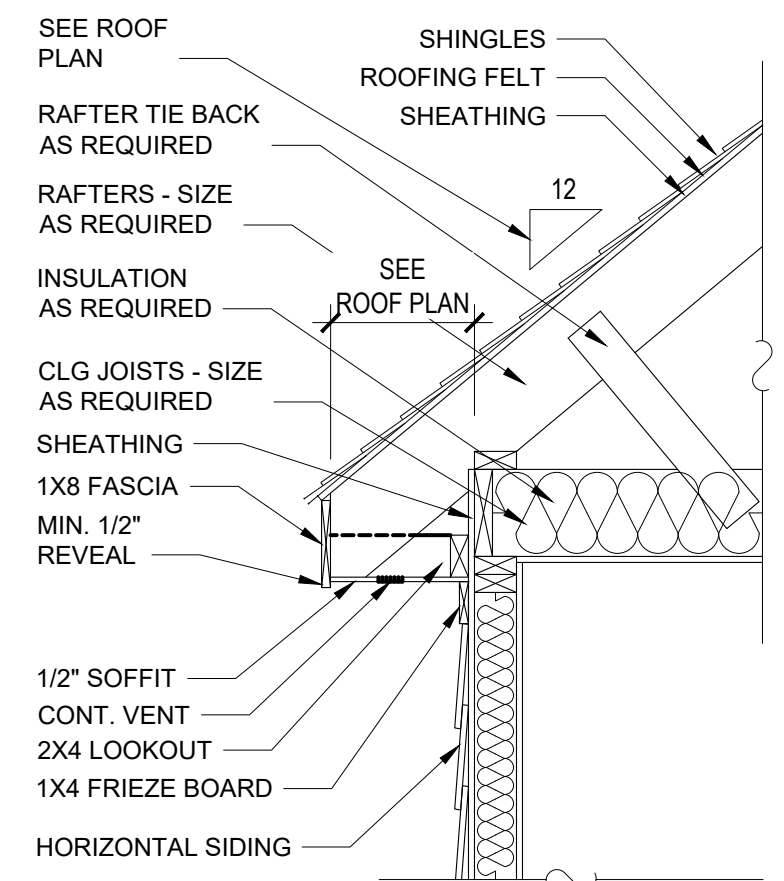

A-7 CORNICE DETAIL
NTS

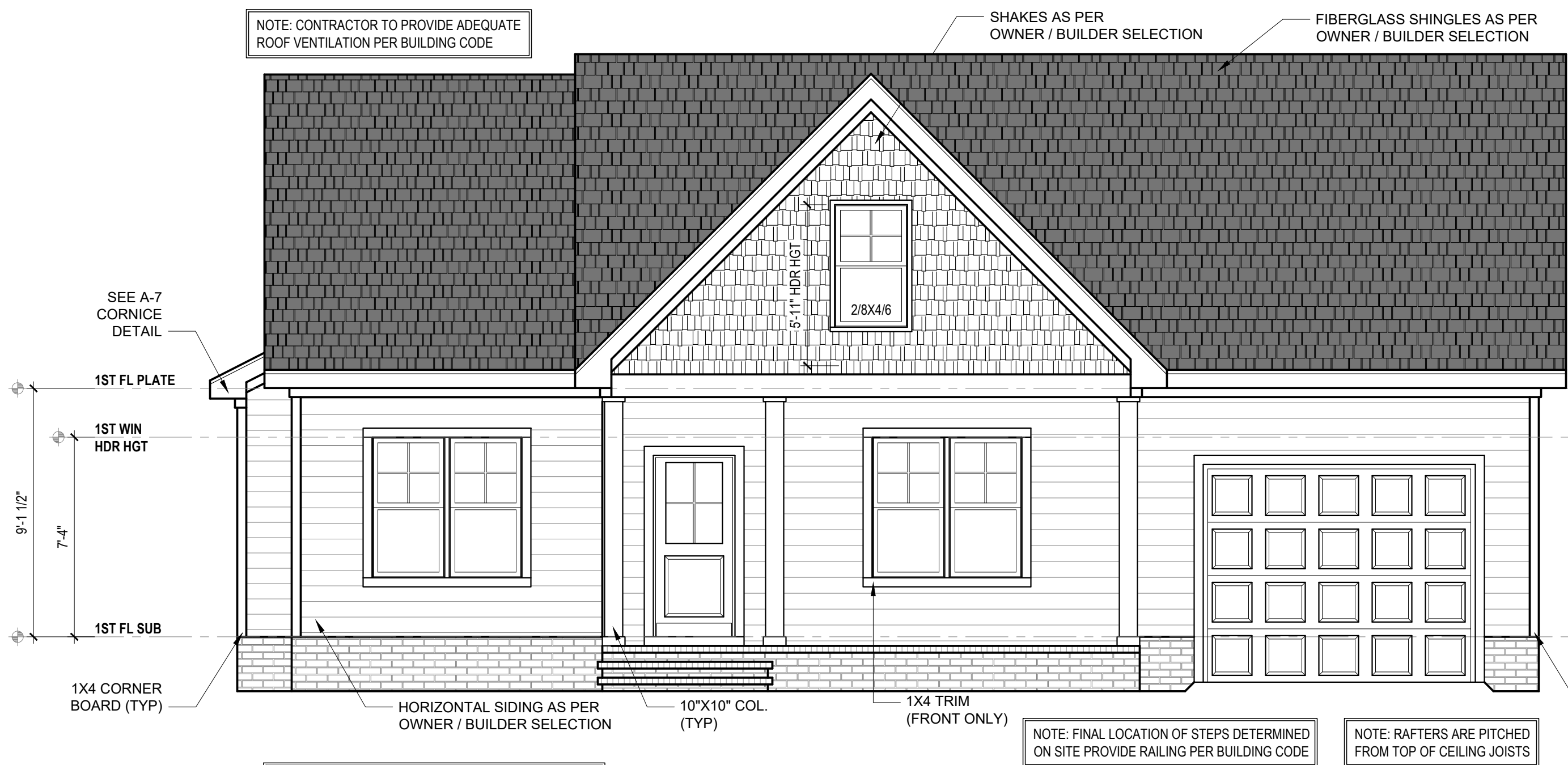

FRONT ELEVATION
1/4" = 1'-0"

NOTE: WHEN TWO ROOFS INTERSECT WITH DIFFERENT ROOF PITCHES, BLOCK TOP OF STUD WALLS AS REQ'D. TO LINE UP FASCIA AT A MINIMUM OF 1'-0" OVERHANG

NOTE: FINAL LOCATION OF STEPS DETERMINED ON SITE PROVIDE RAILING PER BUILDING CODE

NOTE: RAFTERS ARE PITCHED FROM TOP OF CEILING JOISTS



RIGHT ELEVATION
1/4" = 1'-0"

- DRB DESIGN assumes no liability for any home constructed from this plan.
- All construction shall conform to the latest requirements of "North Carolina State 2018 residential building code", in addition to all local codes and regulations.
- Should these plans require structural calculations for permitting the contractor shall be required to obtain the services of a structural engineer after notifying DRB DESIGN that such services are required.
- Release of these plans requires further cooperation among the owner, his/her contractor, and DRB DESIGN.
- Design and construction are complex and, although the designer performed his services with due care and diligence, perfection is not a guarantee.
- Communication is imperfect and every contingency cannot be anticipated.
- Any ambiguity or discrepancy discovered by the use of these plans shall be reported immediately to DRB DESIGN. Failure to notify the DRB DESIGN compounds misunderstandings and increases construction costs.
- A failure to cooperate by a simple notice to DRB DESIGN shall relieve the designer from any and all responsibilities for all consequences.
- Changes made to these plans without the consent of the designer are unauthorized and shall relieve DRB DESIGN of responsibility for any and all consequences arising out of such changes.
- Written dimensions on these plans always have precedence over scaled dimensions.
- It is the contractors responsibility to verify and be responsible for all dimensions and square footage prior to construction, as well as conditions on the job site. DRB DESIGN is not responsible for dimension and square footage errors once construction has begun.
- DRB DESIGN must be notified of any variations from the dimensions and conditions shown on these drawings.

THE WHITLEY

PROJECT #
DRB2101-0126
DATE
07/01/2021
DESIGNED BY
MMB
CHECKED BY
DRB
SCALE
1/4" = 1'-0"

www.
drbhomedeign
.com

PROJECT NAME
THE
WHITLEY

drbdesign@drbhomedeign.com 919.631.5979
250 Shipwash Dr Suite 105 Garner, NC 27529

CLIENT NAME
Pleasant Builders of NC, LLC
2201 Sherrif Johnson Rd.
Lillington, NC 27546
919-878-7685
pleasantbuildersnc@gmail.com

SHEET NAME
ELEVATIONS
SHEET #
A2 of 5

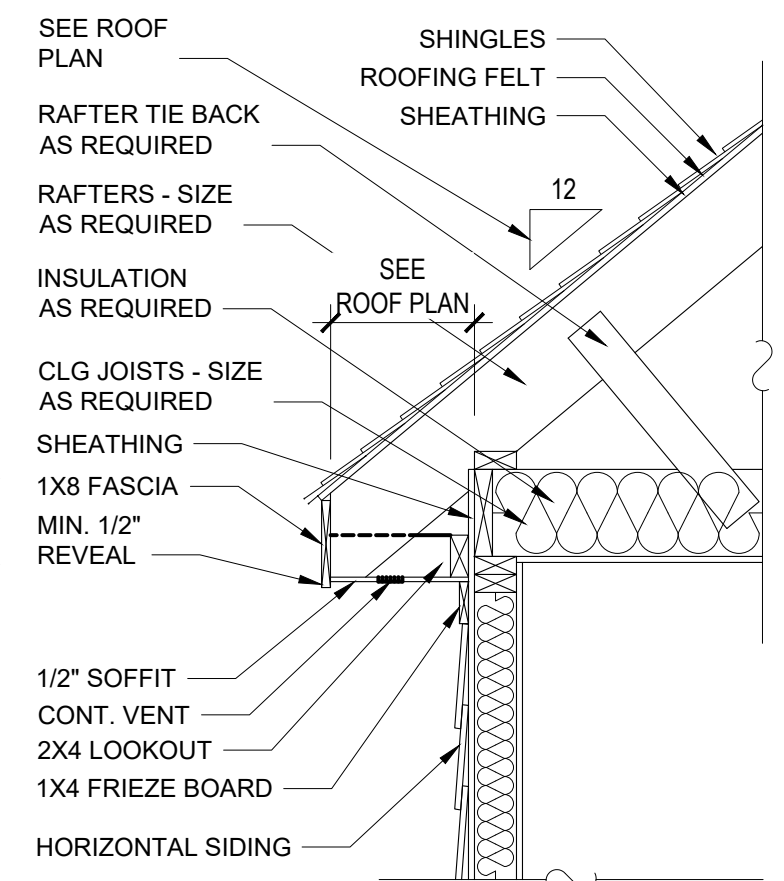

A-7 CORNICE DETAIL
NTS

REAR ELEVATION

1/4" = 1'-0"

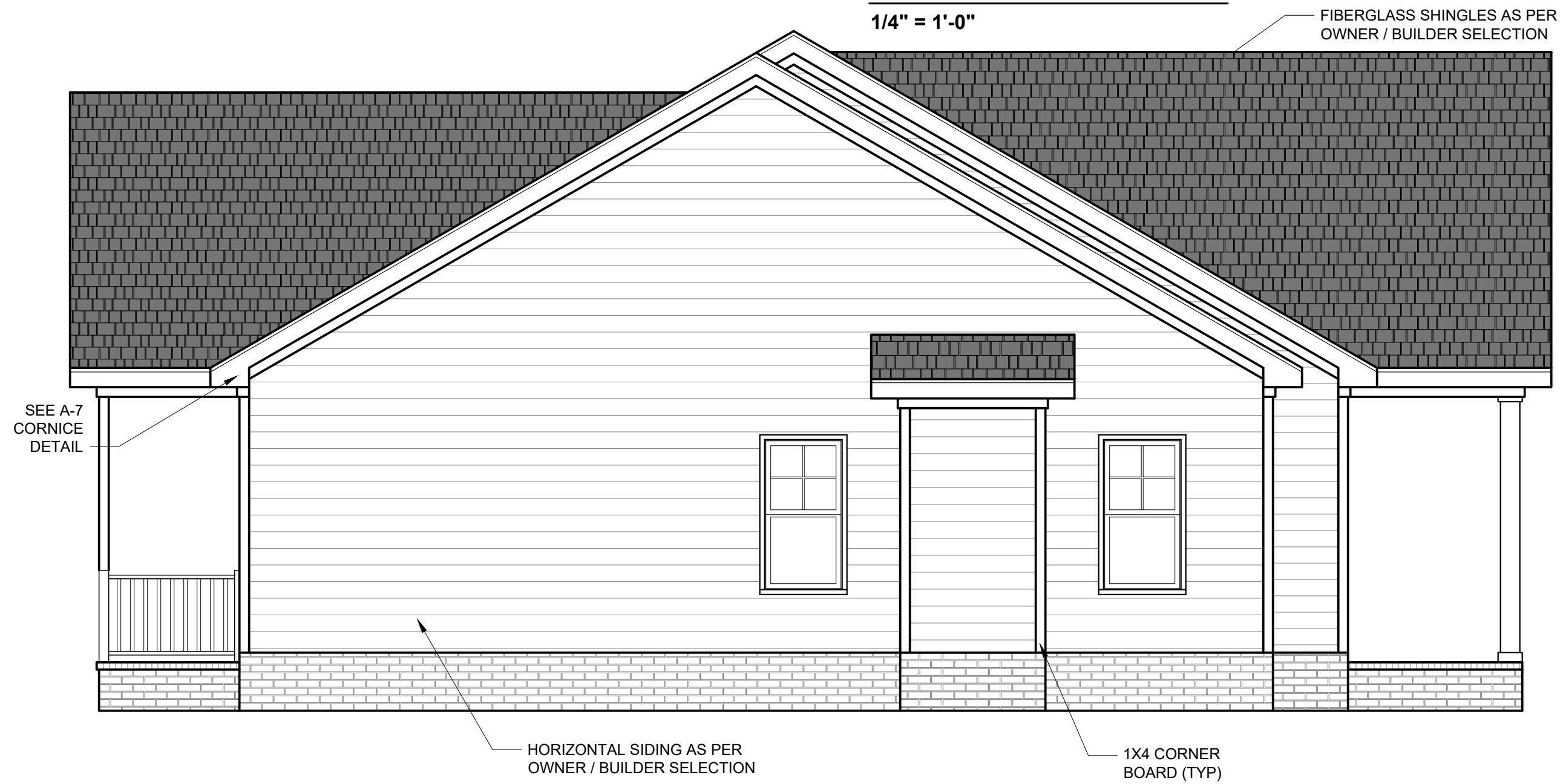

LEFT ELEVATION

1/4" = 1'-0"

1. DRB DESIGN assumes no liability for any home constructed from this plan.
2. All construction shall conform to the latest requirements of "North Carolina State 2018 residential building code", in addition to all local codes and regulations.
3. Should these plans require structural calculations for permitting the contractor shall be required to obtain the services of a structural engineer after notifying DRB DESIGN that such services are required.
4. Release of these plans requires further cooperation among the owner, his/her contractor, and DRB DESIGN.
5. Design and construction are complex and, although the designer performed his services with due care and diligence, perfection is not a guarantee.
6. Communication is imperfect and every contingency cannot be anticipated.
7. Any ambiguity or discrepancy discovered by the use of these plans shall be reported immediately to DRB DESIGN. Failure to notify the DRB DESIGN compounds misunderstandings and increases construction costs.
8. A failure to cooperate by a simple notice to DRB DESIGN shall relieve the designer from any and all responsibilities for all consequences.
9. Changes made to these plans without the consent of the designer are unauthorized and shall relieve DRB DESIGN of responsibility for any and all consequences arising out of such changes.
10. Written dimensions on these plans always have precedence over scaled dimensions.
11. It is the contractors responsibility to verify and be responsible for all dimensions and square footage prior to construction, as well as conditions on the job site. DRB DESIGN is not responsible for dimension and square footage errors once construction has begun.
12. DRB DESIGN must be notified of any variations from the dimensions and conditions shown on these drawings.

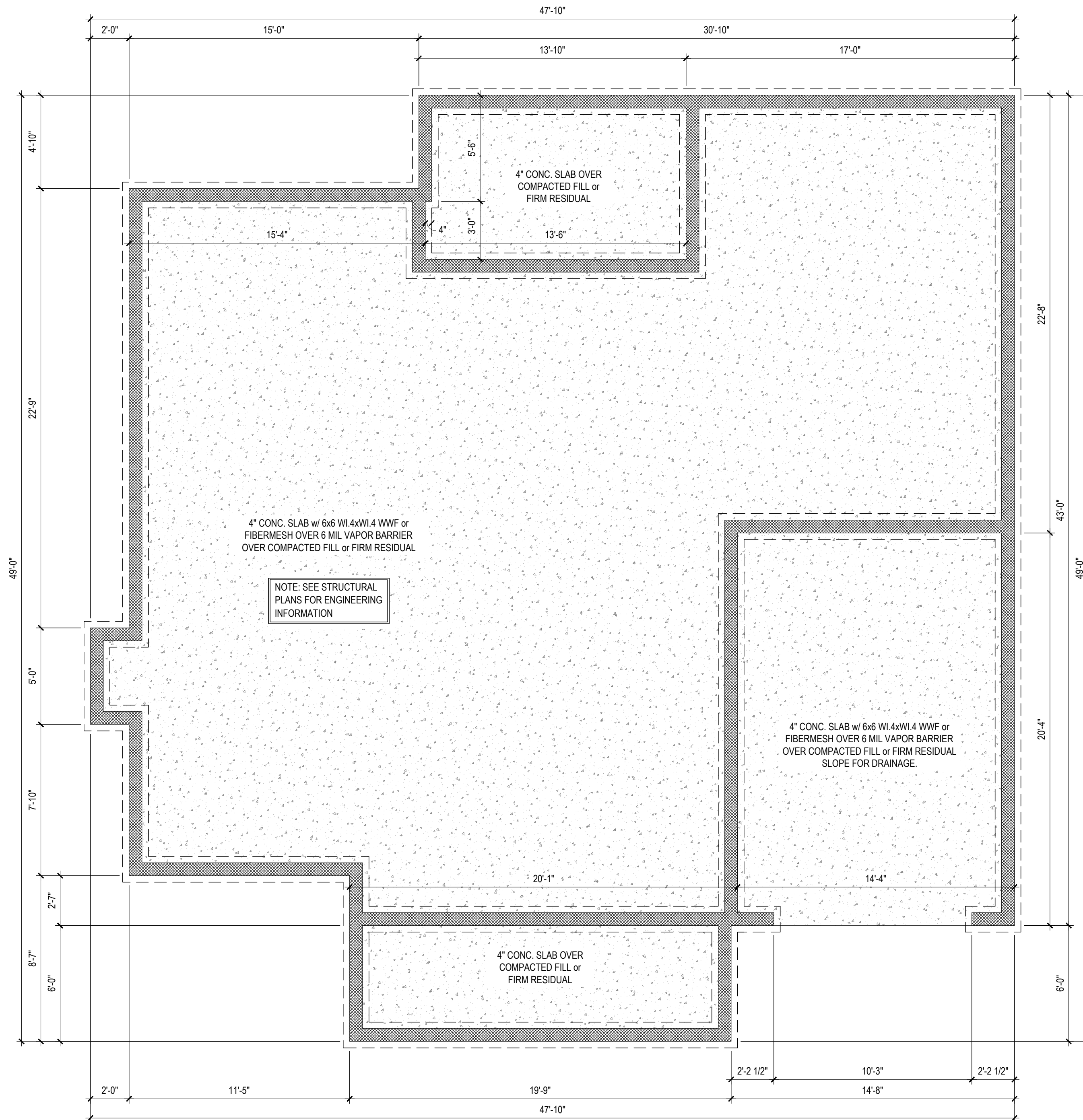

FOUNDATION PLAN
 1/4" = 1'-0" STEM WALL

1. DRB DESIGN assumes no liability for any home constructed from this plan.
2. All construction shall conform to the latest requirements of "North Carolina State 2018 residential building code", in addition to all local codes and regulations.
3. Should these plans require structural calculations for permitting the contractor shall be required to obtain the services of a structural engineer after notifying DRB DESIGN that such services are required.
4. Release of these plans requires further cooperation among the owner, his/her contractor, and DRB DESIGN.
5. Design and construction are complex and, although the designer performed his services with due care and diligence, perfection is not a guarantee.
6. Communication is imperfect and every contingency cannot be anticipated.
7. Any ambiguity or discrepancy discovered by the use of these plans shall be reported immediately to DRB DESIGN. Failure to notify the DRB DESIGN compounds misunderstandings and increases construction costs.
8. A failure to cooperate by a simple notice to DRB DESIGN shall relieve the designer from any and all responsibilities for all consequences.
9. Changes made to these plans without the consent of the designer are unauthorized and shall relieve DRB DESIGN of responsibility for any and all consequences arising out of such changes.
10. Written dimensions on these plans always have precedence over scaled dimensions.
11. It is the contractor's responsibility to verify and be responsible for all dimensions and square footage prior to construction, as well as conditions on the job site. DRB DESIGN is not responsible for dimension and square footage errors once construction has begun.
12. DRB DESIGN must be notified of any variations from the dimensions and conditions shown on these drawings.

PROJECT #
 DRB2101-0126
 DATE
 07/01/2021
 DESIGNED BY
 MMB
 CHECKED BY
 DRB
 SCALE
 1/4" = 1'-0"

www.drbhomedesign.com

THE WHITLEY

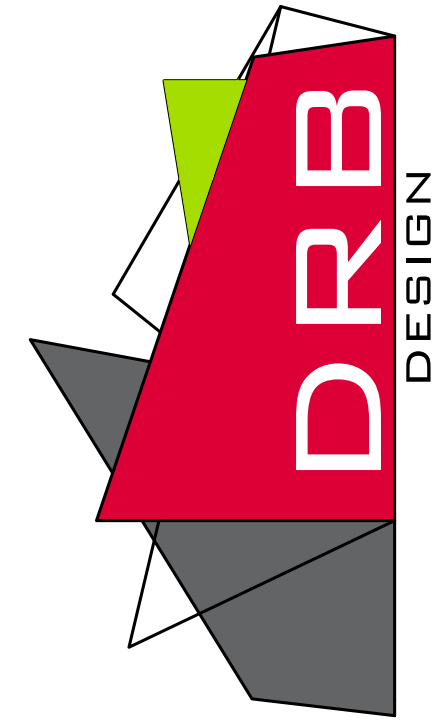

drbdesign@drbhomedesign.com 919.631.5979
 250 Shipwash Dr Suite 105 Garner, NC 27529

CLIENT NAME
 Pleasant Builders of NC, LLC
 2201 Sherrif Johnson Rd.
 Lillington, NC 27546
 919-878-7685
 pleasantbuildersnc@gmail.com

SHEET NAME
 FOUNDATION
 SHEET #
 A3 of 5

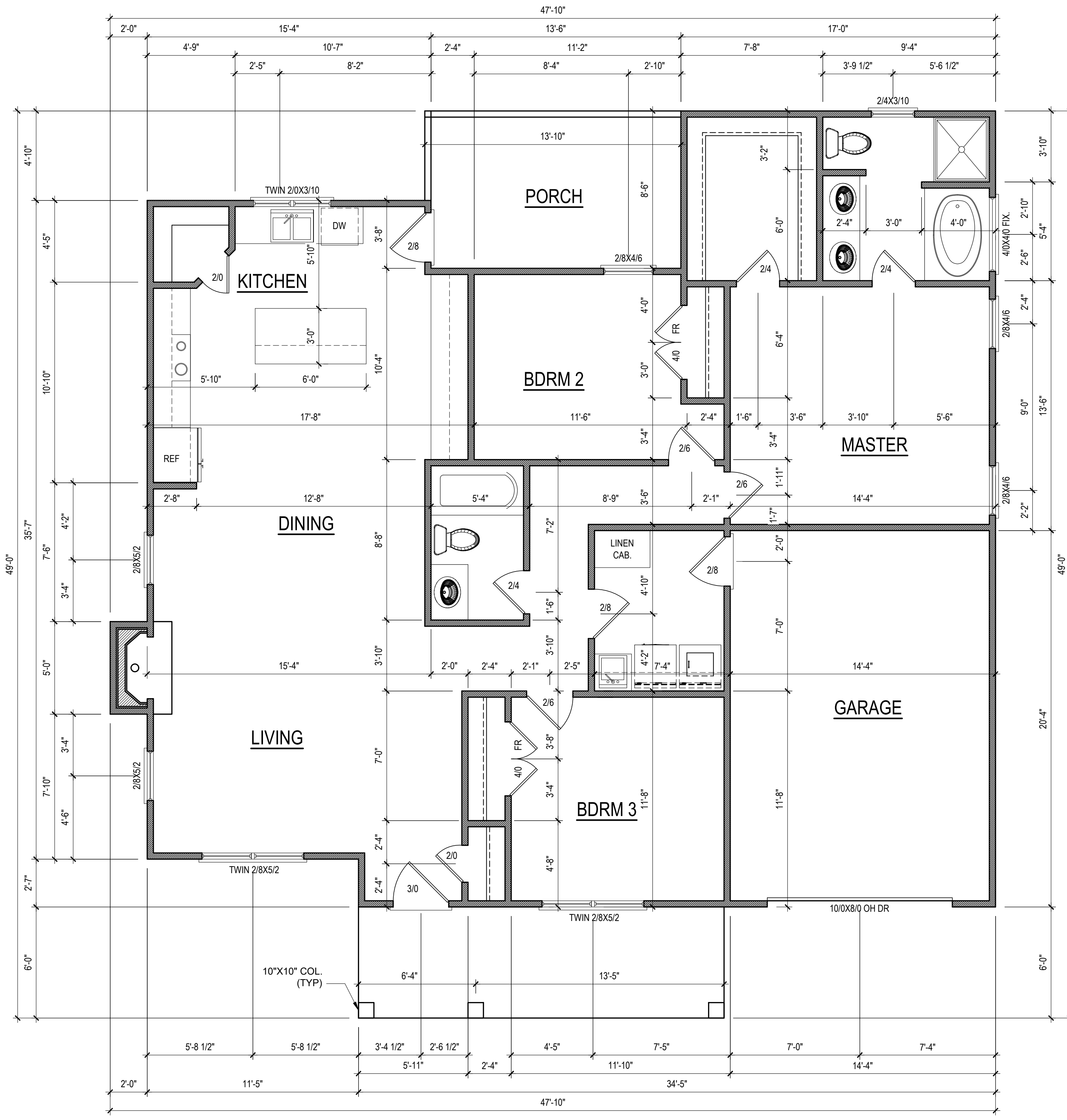

FIRST FLOOR PLAN
 1/4" = 1'-0" CEILING HGT. = 9'-0"

NOTE: VERIFY WINDOW SILL HEIGHT CLEARANCE ABOVE TUBS AND COUNTERTOPS TO ALLOW FOR TRIM AND/OR BACKSPLASH

- DRB DESIGN assumes no liability for any home constructed from this plan.
- All construction shall conform to the latest requirements of "North Carolina State 2018 residential building code", in addition to all local codes and regulations.
- Should these plans require structural calculations for permitting the contractor shall be required to obtain the services of a structural engineer after notifying DRB DESIGN that such services are required.
- Release of these plans requires further cooperation among the owner, his/her contractor, and DRB DESIGN.
- Design and construction are complex and, although the designer performed his services with due care and diligence, perfection is not a guarantee.
- Communication is imperfect and every contingency cannot be anticipated.
- Any ambiguity or discrepancy discovered by the use of these plans shall be reported immediately to DRB DESIGN. Failure to notify the DRB DESIGN compounds misunderstandings and increases construction costs.
- A failure to cooperate by a simple notice to DRB DESIGN shall relieve the designer from any and all responsibilities for all consequences.
- Changes made to these plans without the consent of the designer are unauthorized and shall relieve DRB DESIGN of responsibility for any and all consequences arising out of such changes.
- Written dimensions on these plans always have precedence over scaled dimensions.
- It is the contractor's responsibility to verify and be responsible for all dimensions and square footage prior to construction, as well as conditions on the job site. DRB DESIGN is not responsible for dimension and square footage errors once construction has begun.
- DRB DESIGN must be notified of any variations from the dimensions and conditions shown on these drawings.

HEATED/HABITABLE SQUARE FOOTAGE	
First Floor	1471
TOTAL HEATED	1471
UNHTD SQUARE FOOTAGE	
Front Porch	119
Deck	111
Garage	292
TOTAL UNHEATED	522
TOTAL SQ FT	1993

NOTE:
ALL EXTERIOR WALLS ARE NOMINAL 4" UNO

NOTE:
ALL INTERIOR WALLS ARE NOMINAL 4" UNO

NOTE:
ALL ANGLED WALLS ARE 45° UNO

NOTE:
ALL DIMENSIONS ARE FRAME TO FRAME

PROJECT #
DRB2101-0126
DATE
07/01/2021
DESIGNED BY
MMB
CHECKED BY
DRB
SCALE
1/4" = 1'-0"

www.drbhomedesign.com

THE WHITLEY

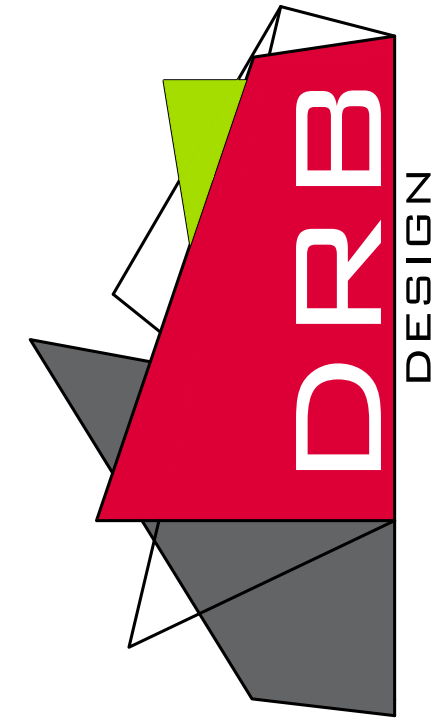

drbdesign@drbhomedesign.com 919.631.5979
 250 Shipwash Dr Suite 105 Garner, NC 27529

CLIENT NAME
Pleasant Builders of NC, LLC
2201 Sherrif Johnson Rd.
Lillington, NC 27546
919-878-7685
pleasantbuildersnc@gmail.com

SHEET NAME
1ST_FLOOR
SHEET #

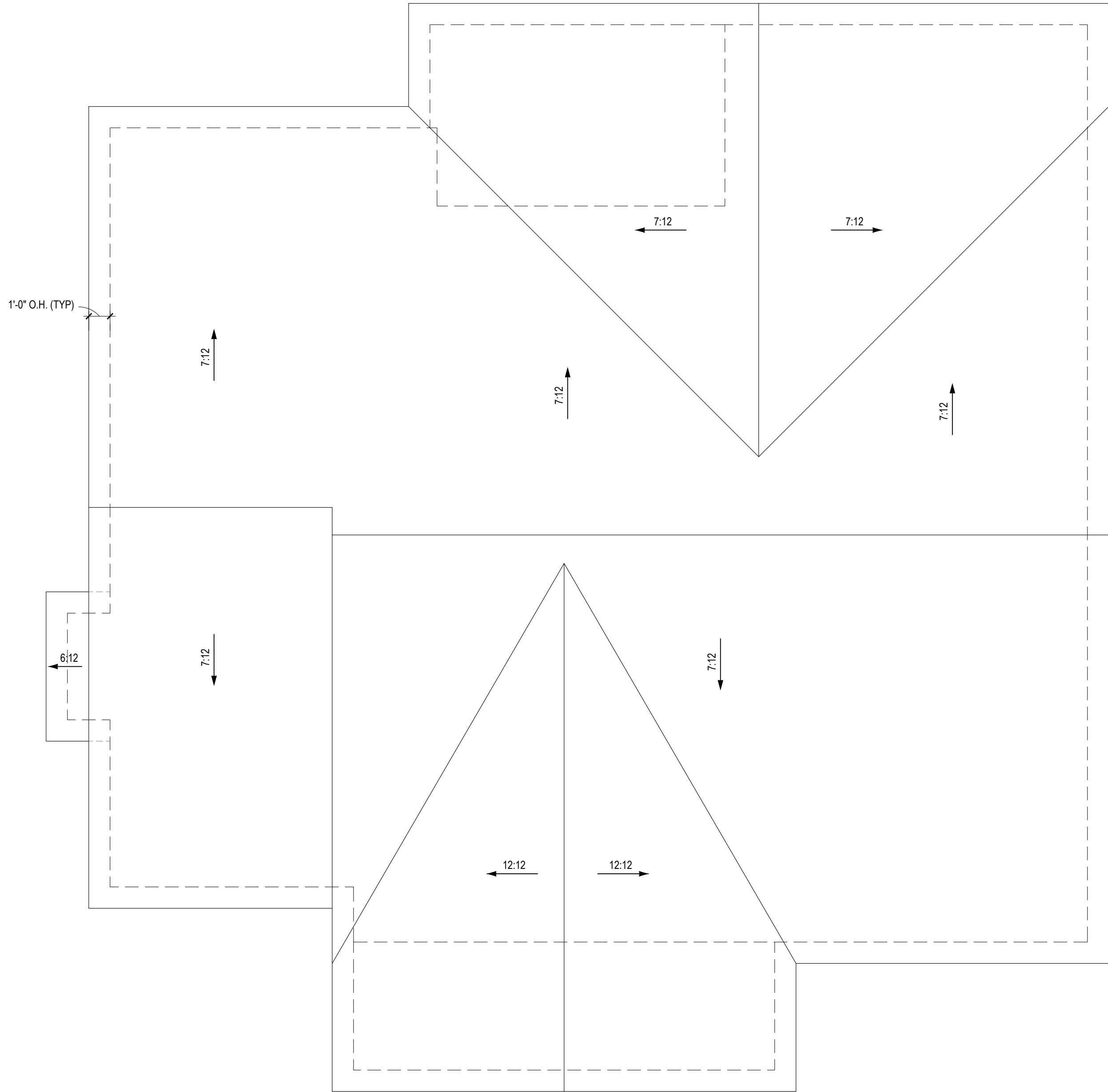

ROOF PLAN

1/4" = 1'-0"

1. DRB DESIGN assumes no liability for any home constructed from this plan.
2. All construction shall conform to the latest requirements of "North Carolina State 2018 residential building code", in addition to all local codes and regulations.
3. Should these plans require structural calculations for permitting the contractor shall be required to obtain the services of a structural engineer after notifying DRB DESIGN that such services are required.
4. Release of these plans requires further cooperation among the owner, his/her contractor, and DRB DESIGN.
5. Design and construction are complex and, although the designer performed his services with due care and diligence, perfection is not a guarantee.
6. Communication is imperfect and every contingency cannot be anticipated.
7. Any ambiguity or discrepancy discovered by the use of these plans shall be reported immediately to DRB DESIGN. Failure to notify the DRB DESIGN compounds misunderstandings and increases construction costs.
8. A failure to cooperate by a simple notice to DRB DESIGN shall relieve the designer from any and all responsibilities for all consequences.
9. Changes made to these plans without the consent of the designer are unauthorized and shall relieve DRB DESIGN of responsibility for any and all consequences arising out of such changes.
10. Written dimensions on these plans always have precedence over scaled dimensions.
11. It is the contractors responsibility to verify and be responsible for all dimensions and square footage prior to construction, as well as conditions on the job site. DRB DESIGN is not responsible for dimension and square footage errors once construction has begun.
12. DRB DESIGN must be notified of any variations from the dimensions and conditions shown on these drawings.

PROJECT #
DRB2101-0126
DATE
07/01/2021
DESIGNED BY
MMB
CHECKED BY
DRB
SCALE
1/4" = 1'-0"



PROJECT NAME
THE
WHITLEY



CLIENT NAME
Pleasant Builders of NC, LLC
2201 Sherrif Johnson Rd.
Lillington, NC 27546
919-878-7685
pleasantbuildersnc@gmail.com

919.631.5979
250 Shipwash Dr Suite 105 Garner, NC 27529

SHEET NAME
ROOF
SHEET #
A5 of 5

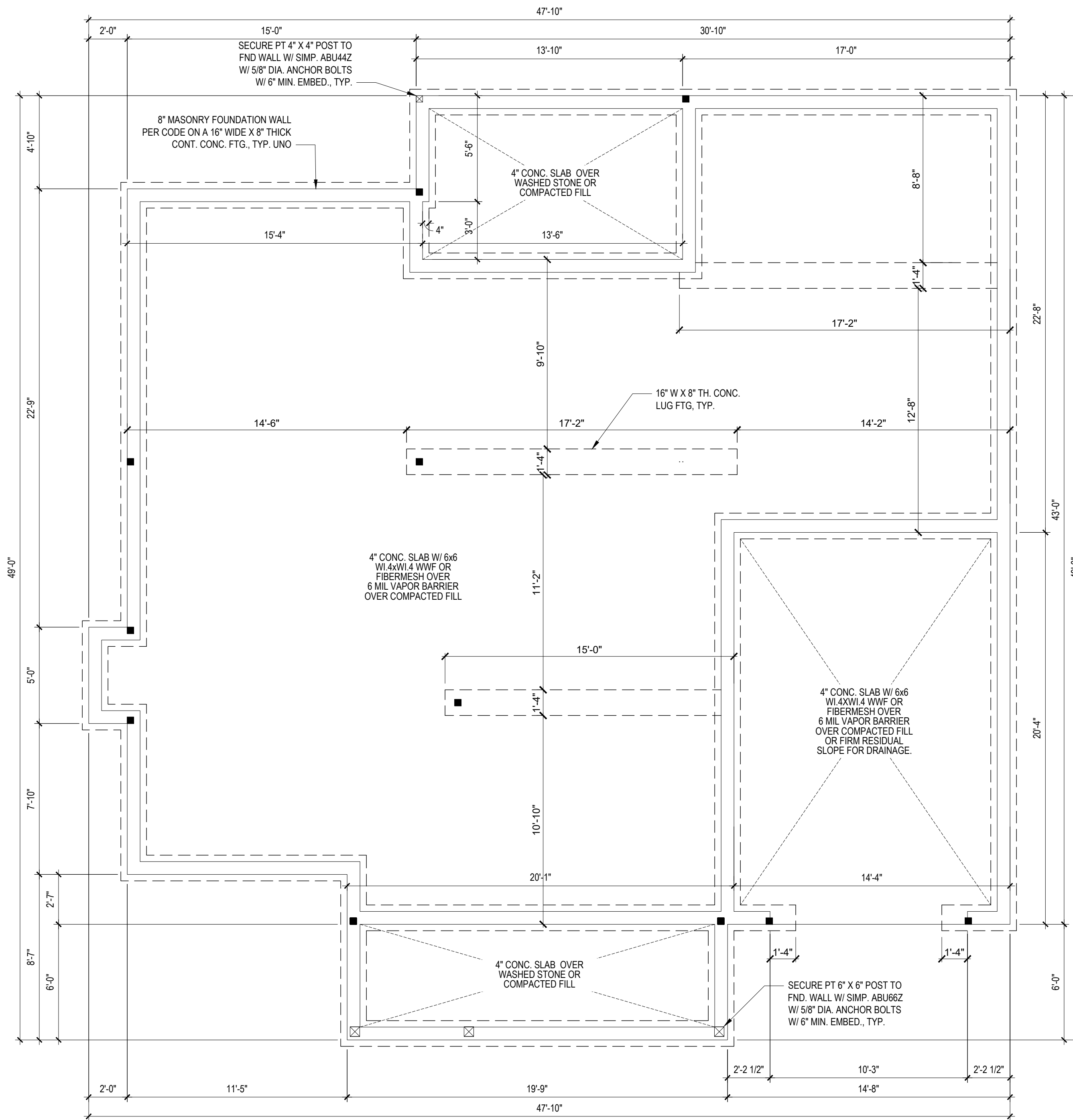

FOUNDATION PLAN
 1/4" = 1'-0"
STEM WALL

Engineers seal does not include construction means, methods, techniques, sequences, procedures or safety precautions.
 Any deviations or discrepancies on plans are to be brought to the immediate attention of Tyndall Engineering & Design, P.A. Failure to do so will void Tyndall Engineering & Design, P.A. liability.
 Please review these documents carefully. Tyndall Engineering & Design, P.A. will interpret that all dimensions, recommendations, etc. presented in these documents were deemed acceptable once construction begins.

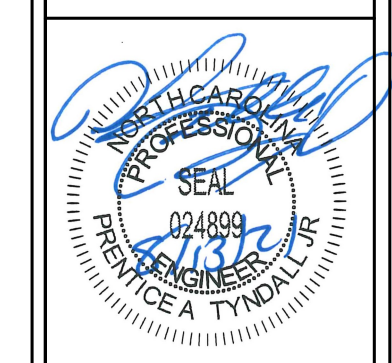

TYNDALL
 ENGINEERING & DESIGN, P.A.

1919 775-3000 • F 919 775-5658
 280 Shipwash Drive • Garner • North Carolina • 27539
 www.tyndalldesign.com

Client: PLEASANT BUILDERS OF NC, LLC

Date: PERSONAL RESIDENCE

FOUNDATION PLAN

Project #:	DRB2101-0126
Date:	08/03/21
Drawn/Design By:	KFR / SM
DWG. Checked By:	PTII
Scale:	SEE PLAN

REVISIONS		
No.	Date	Remarks

Sheet Number
S1
 1 of 5

FILENAME: Z:\DRB_201\DRB2101-0126_PLEASANT_BUILDERS\CAD_FILES\DRB2101-0126_E.DWG, SAVED BY: PLEASANT, TYNDALL, LAST PLOT DATE: 8/13/2021 10:39 AM

* Engineers seal does not include construction means, methods, techniques, sequences, procedures or safety precaution.
 * Any deviations or discrepancies on plans are to be brought to the immediate attention of Tyndall Engineering & Design, P.A.
 * Failure to do so will void Tyndall Engineering & Design, P.A. liability.
 * Please review these documents carefully.
 * Tyndall Engineering & Design, P.A. will interpret that all dimensions, recommendations, etc. presented in these documents were deemed acceptable once construction begins.

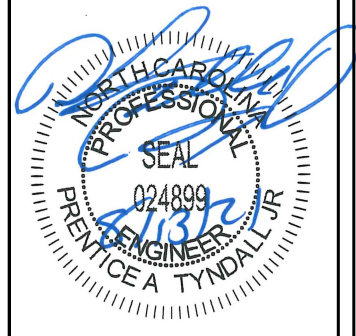

TYNDALL
ENGINEERING & DESIGN, P.A.

199 775-1800 • F 919 775-5688
www.tyndalldesign.com

280 Shipwash Drive • Garner • North Carolina • 27839

PLEASANT BUILDERS OF NC, LLC

PERSONAL RESIDENCE

1ST FLR. HEADER
1ST FLR. CLG.

Project #:	DRB2101-0126
Date:	08/03/21
Drawn/Design By:	KFR / SM
DWG. Checked By:	PTII
Scale:	SEE PLAN

No.	Date	Remarks

Sheet Number
S2
2 of 5

DESIGN LOADS

	LIVE LOAD (PSF)	DEAD LOAD (PSF)	DEFLECTION	
			LL	TL
FLOOR (primary)	40	10	L/360	L/240
FLOOR (secondary)	40	10	L/360	L/240
ATTIC (w/ storage)	20	10	L/240	L/180
ATTIC (no access)	10	5	L/240	L/180
EXTERNAL BALCONY	40	10	L/360	L/240
ROOF	20	10	L/240	L/180
ROOF TRUSS	20	20	L/240	L/180
WIND LOAD	BASED ON 120 MPH (EXPOSURE B)			
SEISMIC	BASED ON SEISMIC ZONES A, B & C			

- STRUCTURAL NOTES:**
- ALL CONSTRUCTION SHALL CONFORM TO THE LATEST REQUIREMENTS OF "NORTH CAROLINA STATE 2018 RESIDENTIAL BUILDING CODE", IN ADDITION TO ALL LOCAL CODES AND REGULATIONS.
 - IT IS THE CONTRACTORS RESPONSIBILITY TO VERIFY ALL DIMENSIONS AND SQUARE FOOTAGE PRIOR TO CONSTRUCTION. TYNDALL ENGINEERING & DESIGN, PA IS NOT RESPONSIBLE FOR DIMENSIONS AND SQUARE FOOTAGE ERRORS ONCE CONSTRUCTION BEGINS.
 - ALL LUMBER SHALL BE SYP #2 (UNO)
 ALL LVL LUMBER TO BE 1.75" WIDE NOMINAL EACH SINGLE MEMBER AND Fb = 2600 PSI, E = 1.9M PSI (I.E. LEVEL MICROLAM)
 ALL LSL LUMBER IS TO BE 1.55E (Fb = 2325 PSI)
 ALL LOAD BEARING EXTERIOR WINDOW HEADERS ARE TO BE (2) 2x10 w/ (1) 2x4 JACK STUD (U.N.O.) AND KING STUDS PER TABLE R602.7.5, AND TOGETHER W/ (2) 10d NAILS @ 8" O.C., PROVIDED THAT THE TOP OF THE WINDOW HEIGHT IS 6'-8", MINIMUM BOTTOM OF THE WINDOW HEIGHT IS 1'-6". OTHERWISE REFER TO TABLES R602.7(1) AND R602.7(2).
 - ALL INTERIOR LOAD BEARING HEADERS TO BE (2) 2x10 (U.N.O.) REFER TO TABLES R602.7(1) AND R602.7(2) FOR JACK STUD REQUIREMENTS FOR HEADER SPANS FOR INTERIOR AND EXTERIOR LOAD CONDITIONS (UNO)
 - REFER TO 2018 NC BUILDING CODE SECTION R602 FOR CONSTRUCTION OF ALL WALLS OVER 10'-0" IN HEIGHT.
 - ALL STRUCTURAL STEEL SHALL BE ASTM A992 GRADE 50
 Fy = 50 KSI MIN. (UNO)
 - ALL EXTERIOR LUMBER TO BE #2 SYP PT
 - ALL CONCRETE, fc = 3000 PSI MIN.
 - PRESUMPTIVE BEARING CAPACITY = 2000 PSF
 - 1/2" Ø ANCHOR BOLTS SPACED AT MAXIMUM OF 6'-0" O.C. AND NOT MORE THAN 12" FROM THE CORNER. THERE SHALL BE A MINIMUM OF (2) BOLTS PER PLATE SECTION. ANCHOR BOLTS SHALL BE SPACED AT 3'-0" O.C. FOR BASEMENTS. ANCHOR BOLT SHALL EXTEND 7" INTO CONCRETE OR MASONRY.
 - PSL COLUMNS DESIGNED WITH MAX. HEIGHT OF 9'-0" (UNO)
 - PROVIDE A MINIMUM OF 500# UPLIFT & LATERAL CONNECTION AT TOP AND BOTTOM OF PORCH COLUMNS. (U.N.O.)
 - PROVIDE CONTINUOUS SHEATHING PER SECTION 602.10.4 OF THE 2018 IRC. MAXIMUM MASONRY PIER HEIGHT SHALL NOT EXCEED FOUR TIMES ITS LEAST HORIZONTAL DIMENSION.
 - UPLIFT LOADS GREATER THAN 500# SHALL BE CONTINUOUSLY ANCHORED TO THE FOUNDATION.
 - METAL HANGERS SHALL BE SIMPSON OR APPROVED EQUAL.

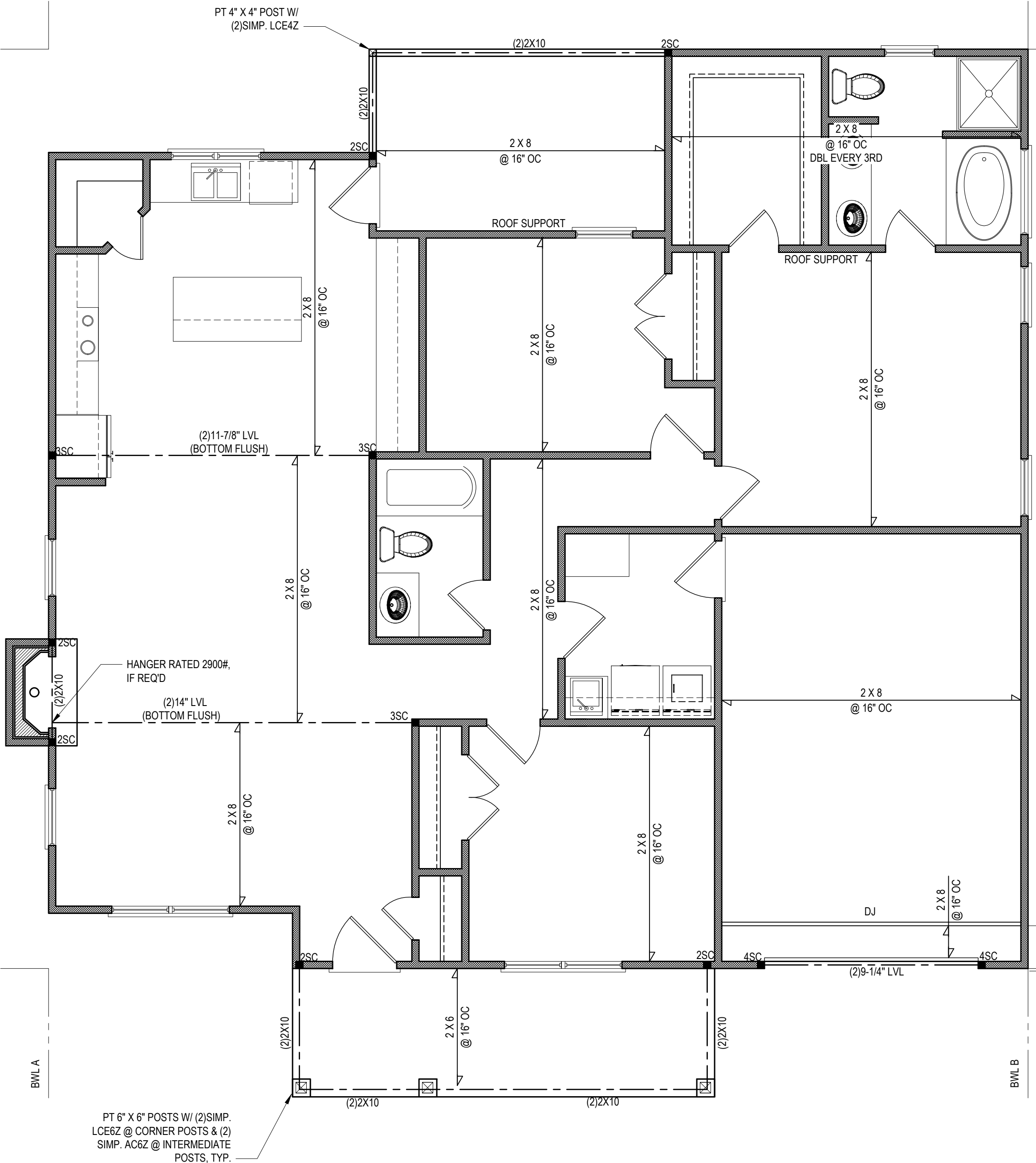

- STRUCTURAL SHEATHING NOTES**
- DESIGNED FOR SEISMIC ZONE A-C AND WIND SPEEDS OF 120 MPH OR LESS.
 - WALLS SHALL BE BRACED IN ACCORDANCE WITH SECTION R602.10 OF THE 2018 NRC.
 - BRACING REQUIREMENTS SHALL BE PER TABLE R602.10.3. REFER TO SECTION R602.10.4 FOR LOAD PATH DETAILS INCLUDING CONNECTIONS & SUPPORT OF BRACED WALL PANELS.
 - REFERENCE FIGURE R602.10.4.3 OF THE 2018 NRC.
 - INTERIOR BRACED WALL PANELS (BWP) INDICATED SHALL BE SHEATHED IN ACCORDANCE WITH THE GB METHOD OR WSP METHOD AS PRESCRIBED IN SECTION R602.10.1 (UNO)
 - 1/2" GYPSUM BOARD (GB) MINIMUM LENGTH OF 8'-0" (ISOLATED PANELS) OR 4'-0" (CONTINUOUS SHEATHING). SECURE W/ 5d COOLER NAILS (OR EQUAL PER TABLE R702.3.5) SPACED @ 7" O.C. AT PANEL EDGES, INCLUDING TOP AND BOTTOM PLATES & 7" O.C. AT INTERMEDIATE SUPPORTS
 - 3/8" WOOD STRUCTURAL PANEL (WSP) SECURE W/ 6d COMMON NAILS SPACED AT 6" O.C. AT PANEL EDGES AND 12" O.C. AT INTERMEDIATE SUPPORTS
 - EXTERIOR BRACED WALL PANELS (BWP) SHALL BE CONSTRUCTED IN ACCORDANCE WITH CS-WSP METHOD AS PRESCRIBED IN SECTION R602.10.3 (UNO)
 - ALL SHEATHABLE SURFACES OF EXTERIOR WALLS (INCLUDING AREAS ABOVE AND BELOW OPENINGS AND GABLE END WALLS) SHALL BE CONTINUOUSLY SHEATHED WITH WOOD STRUCTURAL PANEL (WSP) SHEATHING WITH A MINIMUM THICKNESS OF 3/8". SHEATHING SHALL BE SECURED WITH MINIMUM 6d COMMON NAILS SPACED AT 6" O.C. AT PANEL EDGES AND SPACED AT 12" O.C. AT INTERMEDIATE SUPPORTS. MINIMUM BRACED WALL PANEL LENGTHS WITH CS-WSP METHOD SHALL BE AS FOLLOWS:
 - 24" ADJACENT TO OPENINGS NOT MORE THAN 67% OF WALL HEIGHT
 - 30" ADJACENT TO OPENINGS GREATER THAN 67% AND LESS THAN 85% OF WALL HEIGHT.
 - 48" FOR OPENINGS GREATER THAN 85% OF WALL HEIGHT
 - SHEATH INTERIOR & EXTERIOR
 - FOR CS-WSP METHOD, A MINIMUM 24" BRACED WALL PANEL CORNER RETURN SHALL BE PROVIDED AT BOTH ENDS OF A BRACED WALL LINE IN ACCORDANCE WITH FIGURE R602.10.3(4). IN LIEU OF A CORNER RETURN, EITHER A MIN. 48" BRACED WALL PANEL SHALL BE PROVIDED AT THE CORNER OR A HOLD-DOWN DEVICE WITH A MINIMUM UPLIFT DESIGN VALUE OF 800# SHALL BE FASTENED TO THE EDGE OF THE BRACED WALL PANEL CLOSEST TO THE CORNER AND TO THE FOUNDATION OR FRAMING BELOW.
 - MINIMUM 800# HOLD-DOWN DEVICE

BRACING PANEL LENGTHS REQUIRED:
 BWL A = 6.3 FT
 BWL B = 6.3 FT
 BWL 1 = 6.0 FT
 BWL 2 = 6.0 FT

BRACING PANEL LENGTHS PROVIDED:
 BWL A = 30.25 FT CS-WSP
 BWL B = 32.17 FT CS-WSP
 BWL 1 = 35.17 FT CS-WSP
 BWL 2 = 19.63 FT CS-WSP

FIRST FLOOR PLAN
 1/4" = 1'-0" CEILING HGT. = 9'-0"

FILENAME: Z:\08_2021\082101-0126_PLEASANT_BUILDERS\CAD_FILES\DRB2101-0126_LDWG_SAVED_BY: PRENICE TYNDALL.DWG DATE: 8/13/2021 10:39 AM

* Engineers seal does not include construction means, methods, techniques, sequences, procedures or safety precaution.
 * Any deviations or discrepancies on plans are to be brought to the immediate attention of Tyndall Engineering & Design, P.A.
 * Failure to do so will void Tyndall Engineering & Design, P.A. liability.
 * Please review these documents carefully.
 Tyndall Engineering & Design, P.A. will interpret that all dimensions, recommendations, etc. presented in these documents were deemed acceptable once construction begins.

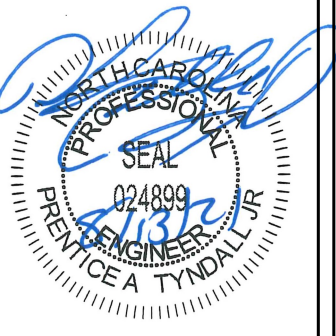

TYNDALL
ENGINEERING & DESIGN, P.A.

199 775-3800 • F 919 775-9488
www.tyndalldesign.com

280 Shipwash Drive • Garner • North Carolina • 27839

Client:	PLEASANT BUILDERS OF NC, LLC
Date:	PERSONAL RESIDENCE

ROOF PLAN

Project #:	DRB2101-0126
Date:	08/03/21
Drawn/Design By:	KFR / SM
DWG. Checked By:	PTII
Scale:	NOT TO SCALE

REVISIONS		
No.	Date	Remarks

Sheet Number
S3
3 of 5

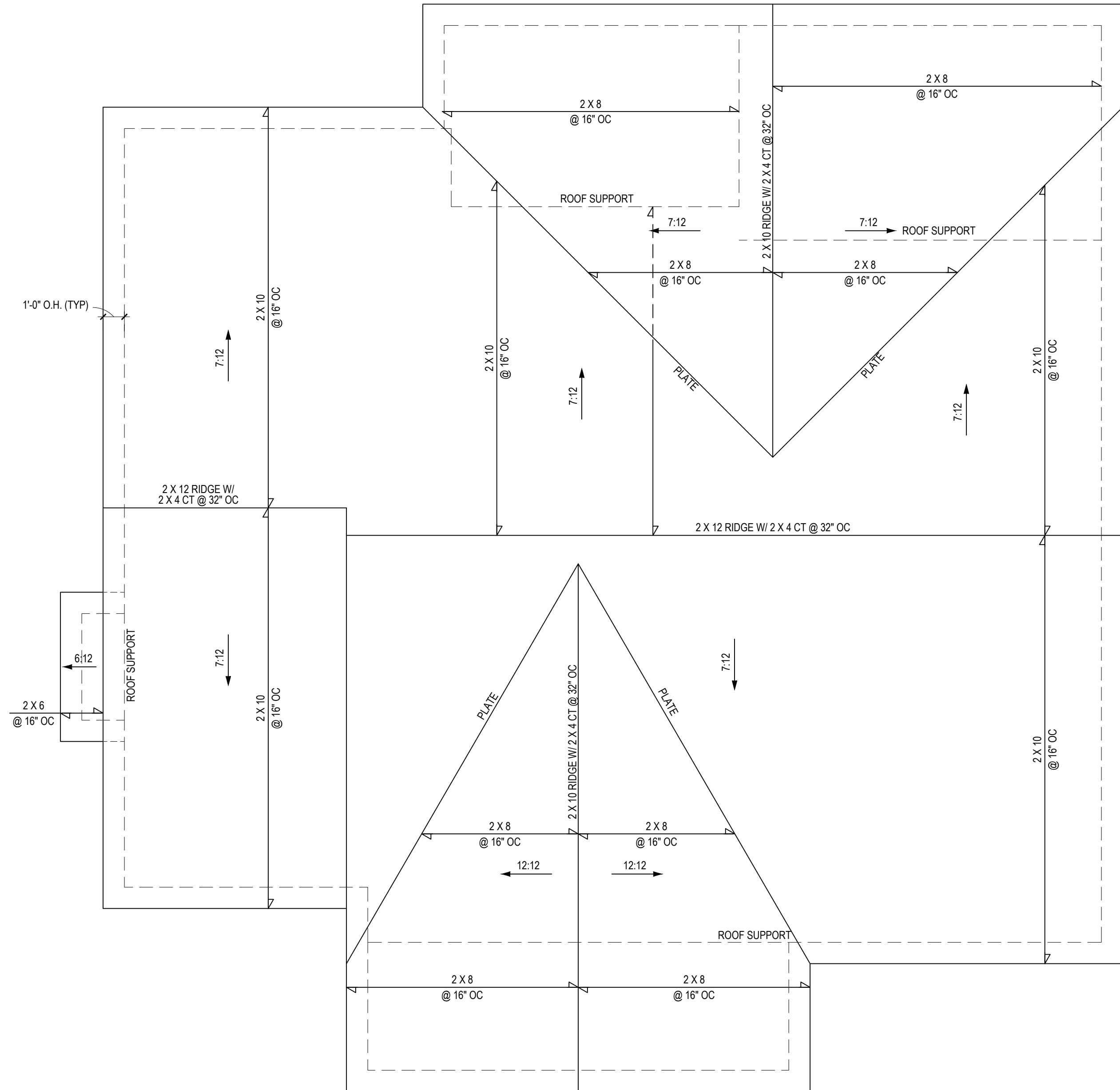

ROOF PLAN
1/4" = 1'-0"

FILENAME: Z:\08_2021\082101-0126_PLEASANT_BUILDERS\CAD_FILES\082101-0126_E.DWG, SAVED BY: PLEASANT, TYNALL, LAST PLOT DATE: 8/13/2021 10:39 AM

STRUCTURAL NOTES

1) ALL CONSTRUCTION SHALL CONFORM TO THE LATEST REQUIREMENTS OF "NORTH CAROLINA STATE 2018 RESIDENTIAL BUILDING CODE", IN ADDITION TO ALL LOCAL CODES AND REGULATIONS.

2) DESIGN LOADS:

	LIVE LOAD (PSF)	DEAD LOAD (PSF)	DEFLECTION	
			LL	TL
ALL FLOORS	40	10	L/360	L/240
ATTIC (w/ walk up stairs)	30	10	L/360	L/240
ATTIC (pull down access)	20	10	L/240	L/180
ATTIC (no access)	10	5	L/240	L/180
EXTERNAL BALCONY	40	10	L/360	L/240
ROOF	20	10	L/240	L/180
ROOF TRUSS	20	20	L/240	L/180
WIND LOAD	BASED ON 120 MPH (EXPOSURE B)			
SEISMIC	SEISMIC ZONES A, B & C			

- 3) MINIMUM ALLOWABLE SOIL BEARING PRESSURE = 2000 PSF
- 4) CONCRETE SHALL HAVE A MINIMUM 28 DAY COMPRESSIVE STRENGTH OF 3000 PSI AND A MAXIMUM SLUMP OF FIVE INCHES UNLESS NOTED OTHERWISE. (U.N.O.)
- 5) MAXIMUM DEPTH OF UNBALANCED FILL AGAINST FOUNDATION WALLS TO BE LESS THAN 4'-0" WITHOUT USING SUFFICIENT WALL BRACING. REFER TO SECTION 404 OF 2018 NC BUILDING CODE FOR BACKFILL LIMITATIONS BASED ON WALL HEIGHT, WALL THICKNESS, SOIL TYPE, AND UNBALANCED BACKFILL HEIGHT.
- 6) ALL FRAMING LUMBER EXPOSED TO THE ELEMENTS SHALL BE TREATED MATERIAL.
ALL LVL LUMBER TO BE 1.75" WIDE NOMINAL EACH SINGLE MEMBER AND F_b = 2500 PSI, E = 1.9M PSI (U.N.O.)
ALL LSL LUMBER TO BE 3.5" WIDE NOMINAL EACH SINGLE MEMBER AND F_b = 2325 PSI, E = 1.6M PSI (U.N.O.)
ALL PSL LUMBER TO BE 3.5" WIDE NOMINAL EACH SINGLE MEMBER AND F_b = 2400 PSI, E = 1.8M PSI (U.N.O.)
- 7) ALL LOAD BEARING EXTERIOR HEADERS SHALL BE AT (2) 2x10, (U.N.O.) REFER TO TABLE R602.7(1) & (2) FOR JACK STUD REQUIREMENTS FOR HEADER SPANS FOR INTERIOR AND EXTERIOR LOAD CONDITIONS UNLESS SPECIFICALLY NOTED ON PLANS.
- 8) ALL STRUCTURAL STEEL W-SHAPES (I-BEAMS) SHALL BE ASTM A992 GRADE 50.
ALL STEEL ANGLES, PLATES, AND C-CHANNELS SHALL BE ASTM A36.
ALL STEEL PIPE SHALL BE ASTM A53 GRADE B.
- 9) STEEL BEAMS SHALL BE SUPPORTED AT EACH END WITH A MINIMUM BEARING LENGTH OF 3'-1/2" AND FULL FLANGE WIDTH. PROVIDE SOLID BEARING FROM BEAM SUPPORT TO FOUNDATION. BEAMS SHALL BE ATTACHED TO EACH SUPPORT WITH TWO (2) LAG SCREWS (1/2" X 4" LONG). LATERAL SUPPORT IS CONSIDERED ADEQUATE PROVIDED THE JOISTS ARE TOE NAILED TO THE SOLE PLATES, AND THE SOLE PLATES ARE NAILED OR BOLTED TO THE BEAM FLANGES @ 48" O.C.
- 11) PROVIDE ANCHOR BOLT PLACEMENT PER SECTION 403.1.6. 1/2" Ø ANCHOR BOLTS SPACED AT 6'-0" O.C. AND PLACED 12" FROM THE END OF EACH PLATE SECTION. ANCHOR BOLTS SHALL BE SPACED AT 3'-0" O.C. FOR BASEMENTS. ANCHOR BOLT SHALL EXTEND 7" INTO CONCRETE OR MASONRY. THE BOLTS SHALL BE LOCATED IN THE MIDDLE THIRD OF THE WIDTH OF THE PLATE. THERE SHALL BE A MINIMUM TWO ANCHOR BOLTS PER PLATE SECTION.
- 12) FOUNDATION DRAINAGE-DAMP PROOFING OR WATERPROOFING PER SECTION 405 AND 406 OF NC BUILDING CODE.
- 13) WALL AND ROOF CLADDING VALUES:
WALL CLADDING SHALL BE DESIGNED FOR 28.0 POUNDS PER SQUARE FOOT (LBS/SQFT) OR GREATER POSITIVE AND NEGATIVE PRESSURE. ROOF VALUES BOTH POSITIVE AND NEGATIVE SHALL BE AS FOLLOWS:
38.0 LBS/SQFT FOR ROOF PITCHES 0/12 TO 1.5/12
38.0 LBS/SQFT FOR ROOF PITCHES 1.5/12 TO 6/12
18.0 LBS/SQFT FOR ROOF PITCHES 6/12 TO 12/12
**MEAN ROOF HEIGHT 30'-0" OR LESS
- 14) FOR ROOF SLOPES FROM 2/12 THROUGH 4/12, BUILDER TO INSTALL 2 LAYERS OF 15# FELT PAPER.
- 15) REFER TO SECTION R602.3 FOR FRAMING OF ALL WALLS OVER 10'-0" IN HEIGHT.
- 16) PROVIDE CONTINUOUS SHEATHING PER SECTION 602.10.3 OF THE 2018 NCR.
- 17) UPLIFT LOADS GREATER THAN 500# SHALL BE CONTINUOUSLY ANCHORED TO THE FOUNDATION.
- 18) REFER TO TABLE N1102.1 FOR PRESCRIPTIVE BUILDING ENVELOPE THERMAL COMPONENT CRITERIA.
- 19) PSL COLUMNS DESIGNED WITH MAXIMUM HEIGHT OF 9'-0" (U.N.O.)
- 20) PROVIDE A MINIMUM OF 500# UPLIFT & LATERAL CONNECTION AT TOP AND BOTTOM OF PORCH COLUMNS. (U.N.O.)
- 21) MAXIMUM MASONRY PEIR HEIGHT SHALL NOT EXCEED FOUR TIMES ITS LEAST HORIZONTAL DIMENSION.
- 22) IT IS THE CONTRACTORS RESPONSIBILITY TO VERIFY ALL DIMENSIONS AND SQUARE FOOTAGE PRIOR TO CONSTRUCTION. TYNDALL ENGINEERING & DESIGN, PA IS NOT RESPONSIBLE FOR DIMENSION OR SQUARE FOOTAGE ERRORS ONCE CONSTRUCTION BEGINS.

DEFINITIONS FOR COMMON ABBREVIATIONS

ALT = ALTERNATE	MAX = MAXIMUM
CANT = CANTILEVER	MIN = MINIMUM
CJ = CEILING JOIST	NOM = NOMINAL
CMU = CONCRETE MASONRY UNIT	O.C. = ON CENTER
COL = COLUMN	PL = POINT LOAD
CONC = CONCRETE	PT = PRESSURE TREATED
CONT = CONTINUOUS	REINF = REINFORCED
CT = COLLAR TIE	REDD = REQUIRED
DBL = DOUBLE	RJ = ROOF JOIST
DIA = DIAMETER	RS = ROOF SUPPORT
DJ = DOUBLE JOIST	SC = STUD COLUMN
DR = DOUBLE RAFTER	SCH = SCHEDULE
EA = EACH	SPEC = SPECIFIED
EE = EACH END	THK = THICK
FJ = FLOOR JOIST	TJ = TRIPLE JOIST
FND = FOUNDATION	TRTD = TREATED
FTG = FOOTING	TRTP = TYPICAL
GALV = GALVANIZED	UNO = UNLESS NOTED OTHERWISE
HORIZ = HORIZONTAL	W = WIDE FLANGE BEAM
HT = HEIGHT	WWF = WELDED WIRE FABRIC
MANUF = MANUFACTURER	XJ = EXTRA JOIST

1) MAXIMUM HEIGHT OF DECK SUPPORT POSTS AS FOLLOWS:

POST SIZE	MAX. POST HEIGHT**
4 x 4	8'-0"
6 x 6	20'-0"
***	OVER 20'-0"

* THIS TABLE IS BASED ON NO. 2 TREATED SOUTHERN PINE POSTS. MAXIMUM TRIBUTARY AREA IS BASED ON 128 TOTAL SQUARE FEET WHICH MAY BE LOCATED AT DIFFERENT LEVELS.
** FROM TOP OF FOOTING TO BOTTOM OF GIRDER
*** DECKS WITH POST HEIGHTS OVER 20'-0" SHALL BE DESIGNED AND SEALED BY A PROFESSIONAL ENGINEER OR REGISTERED ARCHITECT.

2) DECKS SHALL BE BRACED TO PROVIDE LATERAL STABILITY BY ONE OF THESE METHODS:

- A. THE DECK FLOOR HEIGHT IS LESS THAN 4'-0" AND THE DECK IS ATTACHED TO THE STRUCTURE IN ACCORDANCE WITH SECTION (4) ABOVE. LATERAL BRACING IS NOT REQUIRED.
- B. 4 x 4 WOOD KNEE BRACES MAY BE PROVIDED ON EACH COLUMN IN BOTH DIRECTIONS. THE KNEE BRACES SHALL ATTACH TO EACH POST AT A POINT NOT LESS THAN 1/3 OF THE POST LENGTH FROM THE TOP OF THE POST, AND THE BRACES SHALL BE ANGLED BETWEEN 45° AND 60° FROM THE HORIZONTAL. KNEE BRACES SHALL BE BOLTED TO THE POST AND GIRDER WITH ONE 5/8" Ø HOT DIPPED GALVANIZED BOLT AT EACH END OF THE BRACE.
- C. FOR FREESTANDING DECKS WITHOUT KNEE BRACES OR DIAGONAL BRACING, LATERAL STABILITY MAY BE PROVIDED BY EMBEDDING THE POSTS IN ACCORDANCE WITH THE FOLLOWING:

POST SIZE	MAX. TRIBUTARY AREA	MAX. POST HEIGHT	EMBEDMENT DEPTH	CONCRETE DIAMETER
4 x 4	48 SQ. FT.	4'-0"	2'-6"	1'-0"
6 x 6	120 SQ. FT.	6'-0"	3'-6"	1'-8"

- D. 2 x 6 DIAGONAL VERTICAL CROSS BRACING MAY BE PROVIDED IN TWO (2) PERPENDICULAR DIRECTIONS FOR FREESTANDING DECKS OR PARALLEL TO THE STRUCTURE AT THE EXTERIOR COLUMN LINE FOR ATTACHED DECKS. THE 2 x 6 SHALL BE ATTACHED TO THE POSTS WITH ONE 5/8" Ø HOT DIPPED GALVANIZED BOLT AT EACH END OF EACH BRACING MEMBER.
- E. FOR EMBEDMENT OF PILES IN COASTAL REGIONS, SEE CHAPTER 46.

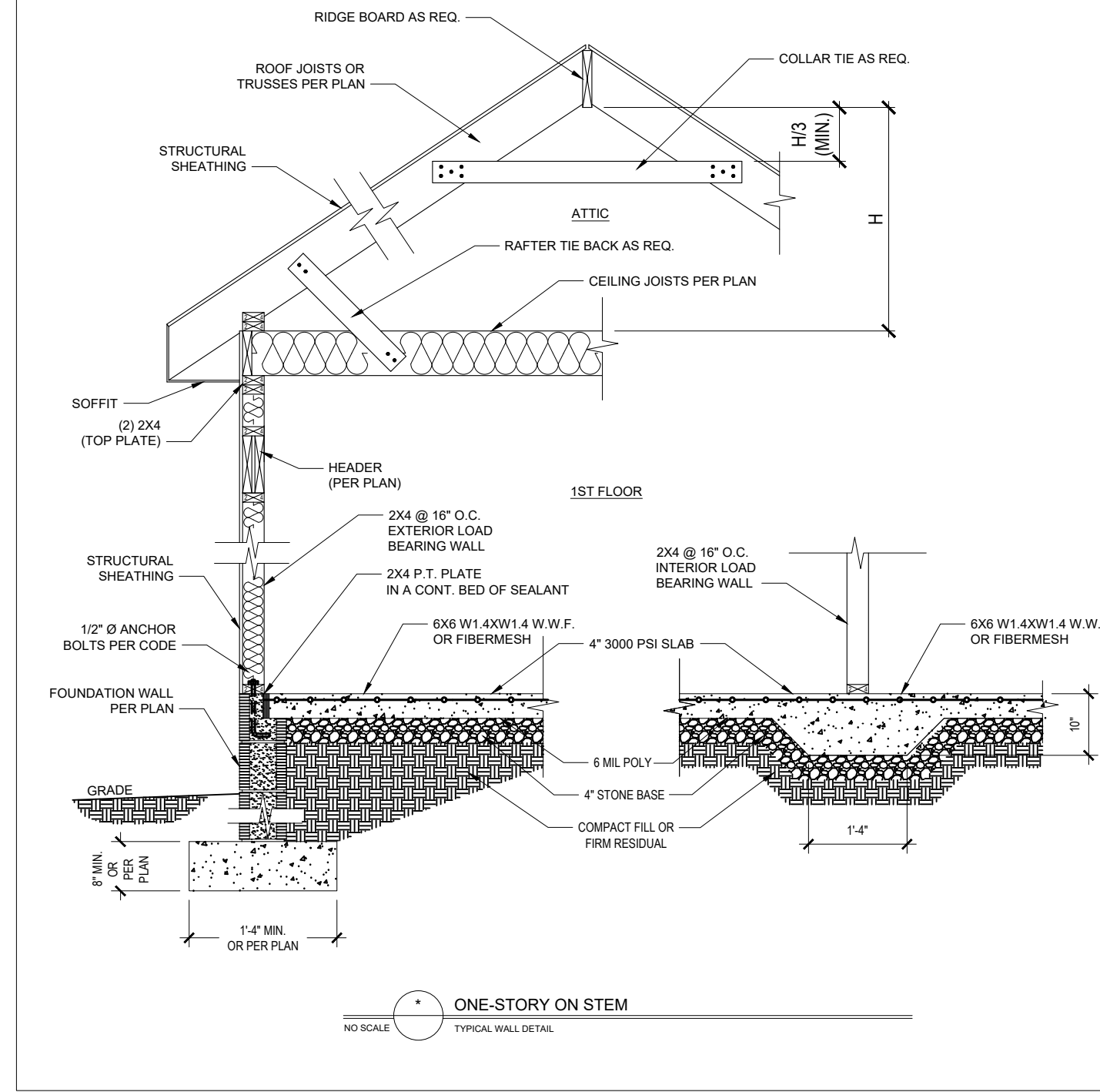

ONE-STORY ON STEM
NO SCALE

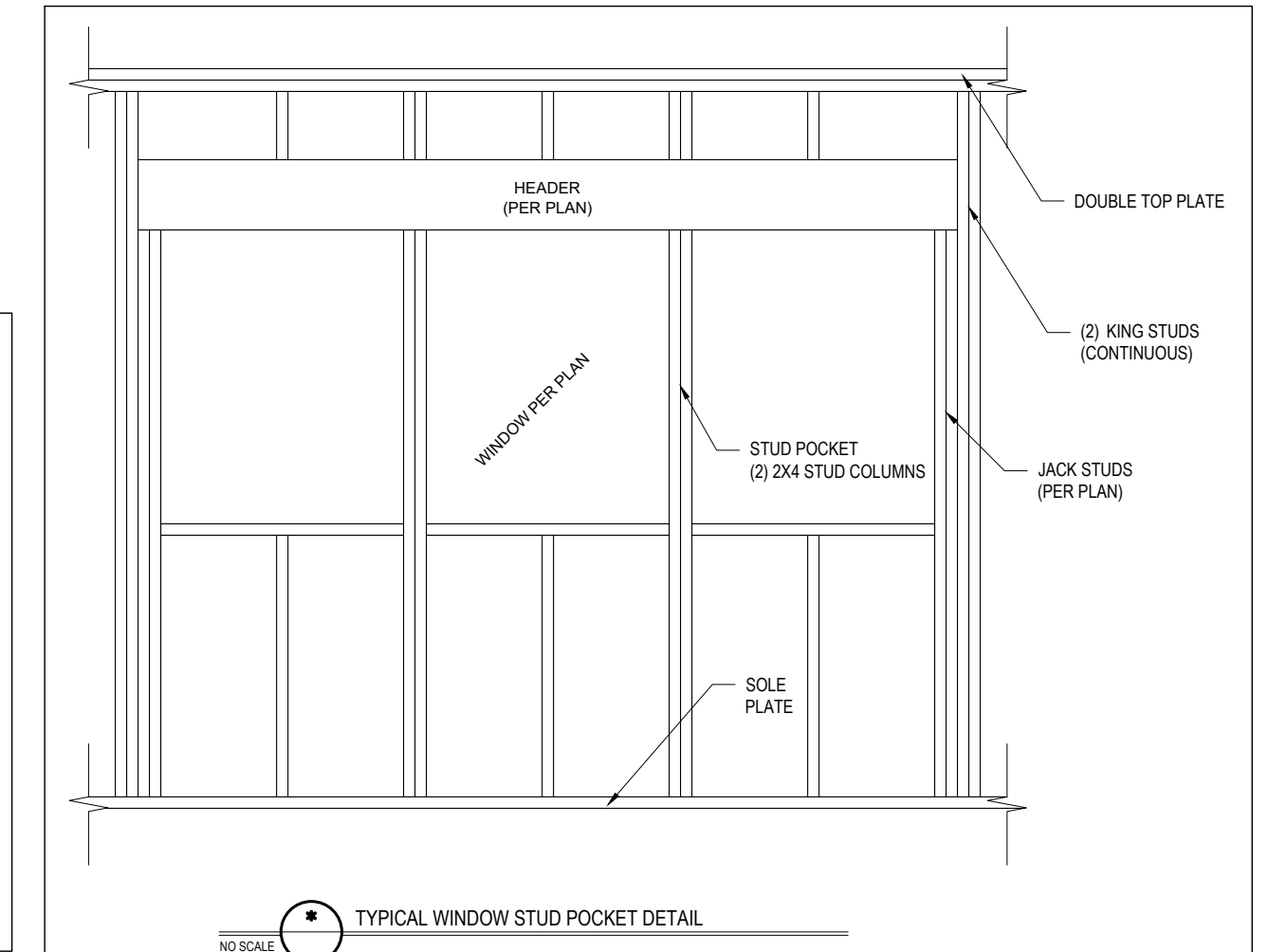

TYPICAL WINDOW STUD POCKET DETAIL
NO SCALE

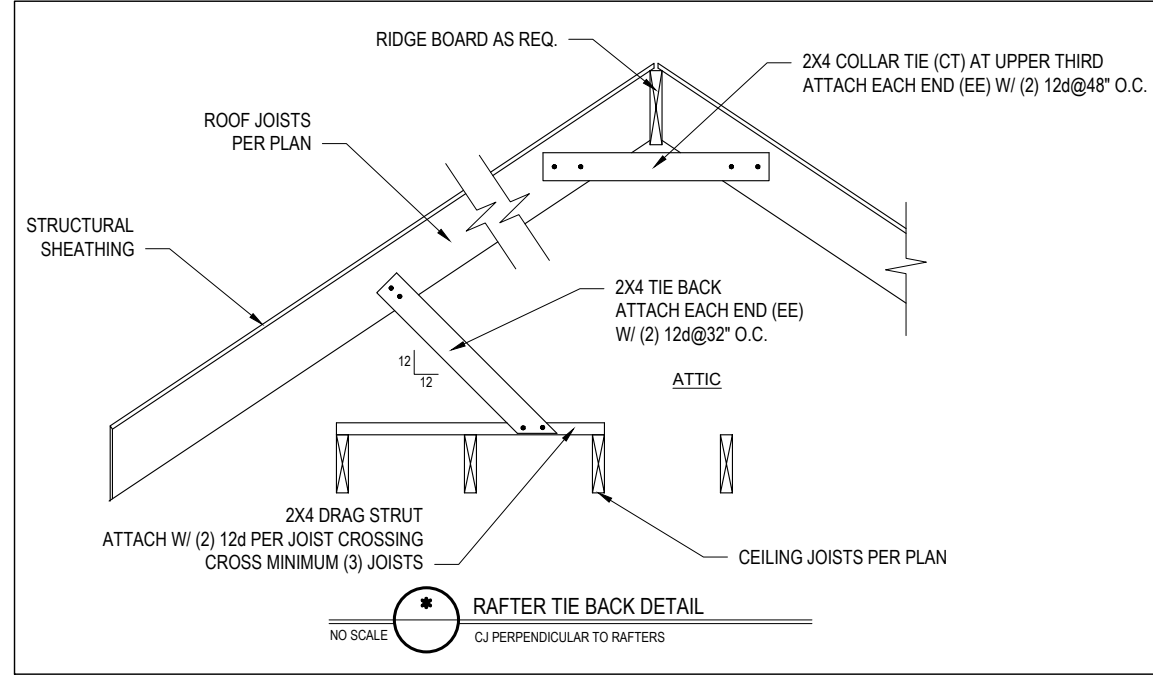

RAFTER TIE BACK DETAIL
NO SCALE

CLIMATE ZONES	FENESTRATION U-FACTOR ^a	SKYLIGHT U-FACTOR ^b	GLAZED FENESTRATION SHGC ^{a,b}	CEILING ^c	WOOD FRAMED WALL R-VALUE	MASS WALL R-VALUE ^d	FLOOR R-VALUE	BASEMENT WALL R-VALUE ^e	SLAB ^d	CRAWL SPACE WALL R-VALUE ^c
3	0.35	0.55	0.30	38 or 30 cont	15 or 13 + 2.5	5/13 or 5/10 cont	19	5/13	0	5/13
4	0.35	0.55	0.30	38 or 30 cont	15 or 13 + 2.5	5/13 or 5/10 cont	19	10/15	10	10/15
5	0.35	0.55	NR	38 or 30 cont	19 or 13 + 5 or 15 + 3	13/17 or 13/12.5 cont	30 ^g	10/15	10	10/19

TABLE N1102.1 CLIMATE ZONES 3-5

a. R-VALUES ARE MINIMUMS. U-FACTORS AND SHGC ARE MAXIMUMS. WHEN INSULATION IS INSTALLED IN A CAVITY WHICH IS LESS THAN THE LABEL OR DESIGN THICKNESS OF THE INSULATOR, THE INSTALLED R-VALUE OF THE INSULATION SHALL NOT BE LESS THAN THE R-VALUE SPECIFIED IN THE TABLE.

b. THE FENESTRATION U-FACTOR COLUMN EXCLUDES SKYLIGHTS. THE SOLAR HEAT GAIN COEFFICIENT (SHGC) COLUMN APPLIES TO ALL GLAZED FENESTRATION.

c. "10\"/>

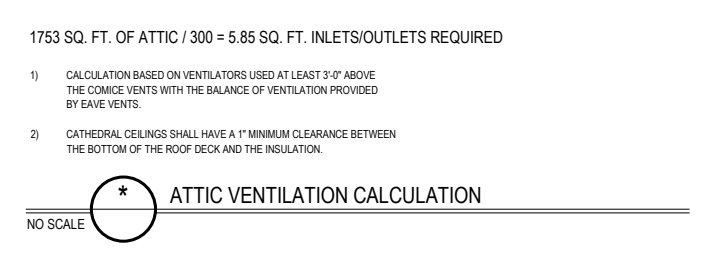

ATTIC VENTILATION CALCULATION
NO SCALE

* Engineers seal does not include construction means, methods, techniques, sequences, procedures or safety precautions.
* Any deviations or discrepancies on plans are to be brought to the immediate attention of Tyndall Engineering & Design, P.A. Failure to do so will void Tyndall Engineering & Design, P.A. liability.
* Please review these documents carefully. Tyndall Engineering & Design, P.A. will interpret that all dimensions, recommendations, etc. presented in these documents were deemed acceptable once construction begins.

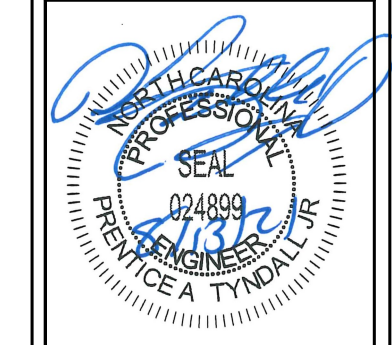

TYNDALL ENGINEERING & DESIGN, P.A.
199 775-3800 • F 919 775-5488
www.tyndalleengineering.com

280 Shipwash Drive • Garner • North Carolina • 27839

PLEASANT BUILDERS OF NC, LLC
PERSONAL RESIDENCE

STANDARD DETAILS

Project #: DRB2101-0126
Date: 08/03/21
Drawn/Design By: KFR / SM
DWG. Checked By: PTH
Scale: NOT TO SCALE

No.	Date	Remarks

Sheet Number
D1
4 of 5

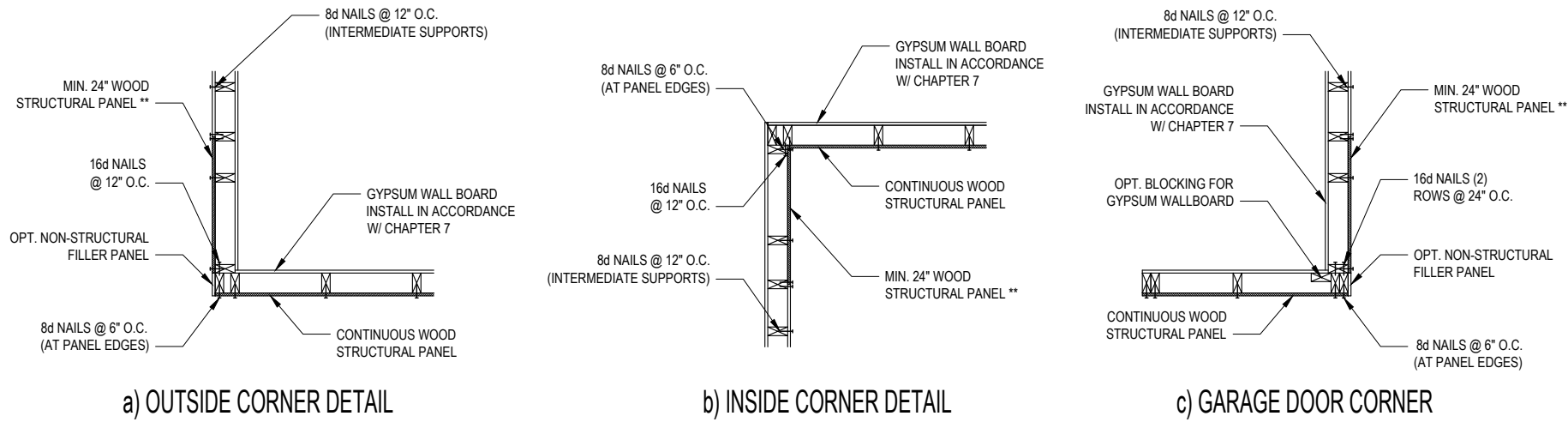

B1: TYPICAL EXTERIOR CORNER FRAMING FOR CONTINUOUS SHEATHING
NO SCALE

STRUCTURAL SHEATHING NOTES

- DESIGNED FOR SEISMIC ZONE A-C AND WIND SPEEDS OF 120 MPH OR LESS.
- WALLS SHALL BE BRACED IN ACCORDANCE WITH SECTION R602.10.3 OF THE 2018 NRC.
- BRACING REQUIREMENTS SHALL BE PER TABLE R602.10.3. REFER TO SECTION R602.10.4 FOR LOAD PATH DETAILS INCLUDING CONNECTIONS & SUPPORT OF BRACED WALL PANELS.
- INTERIOR BRACED WALL PANELS (BWP) INDICATED SHALL BE SHEATHED IN ACCORDANCE WITH THE GB METHOD OR WSP METHOD AS PRESCRIBED IN SECTION R602.10.1 (LNU).
- 12" GYPSUM BOARD (GB) MINIMUM LENGTH OF 8'-0" (ISOLATED PANELS) OR 4'-0" (CONTINUOUS SHEATHING)
- 3/8" WOOD STRUCTURAL PANEL (WSP) SECURE W/ 6d COMMON NAILS SPACED AT 6" O.C. AT PANEL EDGES AND 12" O.C. AT INTERMEDIATE SUPPORTS
- EXTERIOR BRACED WALL PANELS (BWP) SHALL BE CONSTRUCTED IN ACCORDANCE WITH CS-WSP METHOD AS PRESCRIBED IN SECTION R602.10.3 (LNU)
- ALL SHEATHABLE SURFACES OF EXTERIOR WALLS INCLUDING AREAS ABOVE AND BELOW OPENINGS AND GABLE END WALLS SHALL BE CONTINUOUSLY SHEATHED WITH WOOD STRUCTURAL PANEL (WSP) SHEATHING WITH A MINIMUM THICKNESS OF 3/8". SHEATHING SHALL BE SECURED WITH MINIMUM 6d COMMON NAILS SPACED AT 6" O.C. AT PANEL EDGES AND SPACED AT 12" O.C. AT INTERMEDIATE SUPPORTS
- MINIMUM BRACED WALL PANEL LENGTHS WITH CS-WSP METHOD SHALL BE AS FOLLOWS:
 - 24" ADJACENT TO OPENINGS NOT MORE THAN 67% OF WALL HEIGHT
 - 30" ADJACENT TO OPENINGS GREATER THAN 67% AND LESS THAN 85% OF WALL HEIGHT
 - 48" FOR OPENINGS GREATER THAN 85% OF WALL HEIGHT
- SHEATH INTERIOR AND EXTERIOR
- FOR CS-WSP METHOD, A MINIMUM 24" BRACED WALL PANEL CORNER RETURN SHALL BE PROVIDED AT BOTH ENDS OF A BRACED WALL LINE IN ACCORDANCE WITH FIGURE R602.10.3 (4). IN LIEU OF A CORNER RETURN, EITHER A MINIMUM 48" BRACED WALL PANEL SHALL BE PROVIDED AT THE CORNER OR A HOLD-DOWN DEVICE WITH A MINIMUM UPLIFT DESIGN VALUE OF 800# SHALL BE FASTENED TO THE EDGE OF THE BRACED WALL PANEL CLOSEST TO THE CORNER AND TO THE FOUNDATION OR FRAMING BELOW
- MINIMUM 800# HOLD-DOWN DEVICE

REQUIRED BRACED WALL PANEL CONNECTIONS				
METHOD	MATERIAL	MIN. THICKNESS	REQUIRED CONNECTION	
			@ PANEL EDGES	@ INTERMEDIATE SUPPORTS
CS-WSP	WOOD STRUCTURAL PANEL	3/8"	6d COMMON NAILS @ 6" O.C.	6d COMMON NAILS @ 12" O.C.
GB	GYPSUM BOARD	1/2"	5d COOLER NAIL** @ 7" O.C.	5d COOLER NAIL** @ 7" O.C.
WSP	WOOD STRUCTURAL PANEL	3/8"	6d COMMON NAILS @ 6" O.C.	6d COMMON NAILS @ 12" O.C.

B3: BRACE WALL PANEL CONNECTIONS
NO SCALE

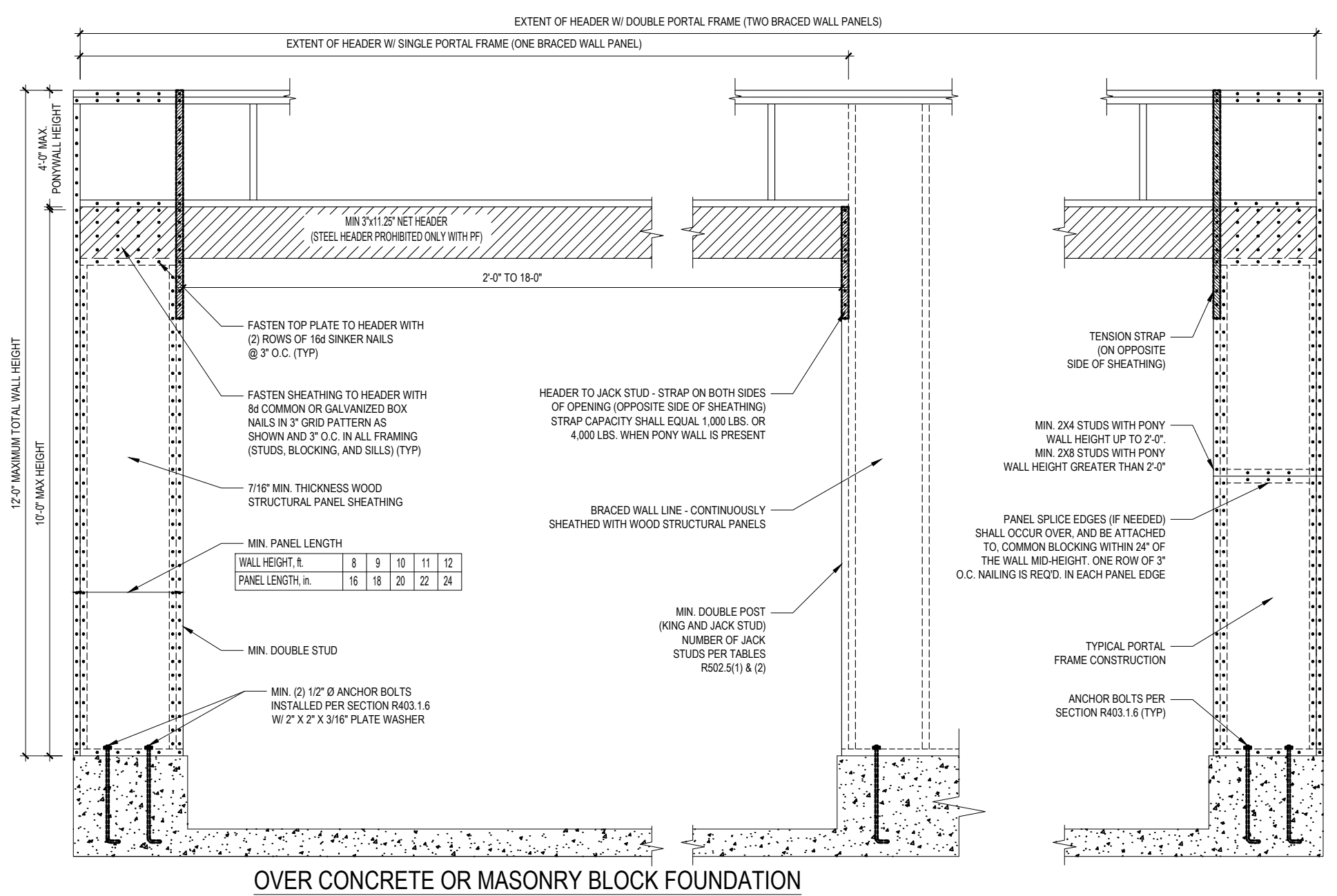

B2: METHOD CS-PF: CONTINUOUSLY SHEATHED PORTAL FRAME
FIGURE R602.10.1

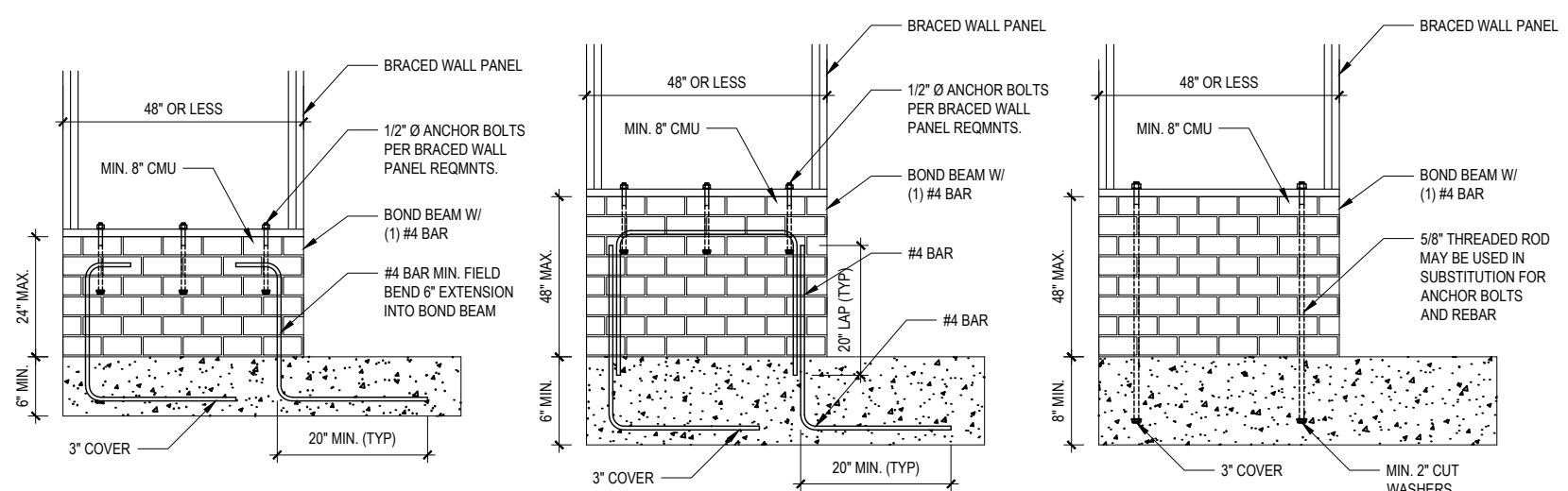

B4: MASONRY STEM WALL SUPPORTING BRACED WALL PANELS
FIGURE R602.10.4 OF THE 2018 NRC
NOTE: GROUT BOND BEAMS AND ALL CELLS WHICH CONTAIN REBAR, THREADED RODS AND ANCHOR BOLTS

Engineers seal does not include construction means, methods, techniques, sequences, procedures or safety precautions. Any deviations or discrepancies on plans are to be brought to the immediate attention of Tyndall Engineering & Design, P.A. Failure to do so will void Tyndall Engineering & Design, P.A. liability. Please review these documents carefully. Tyndall Engineering & Design, P.A. will interpret that all dimensions, recommendations, etc. presented in these documents were deemed acceptable once construction begins.

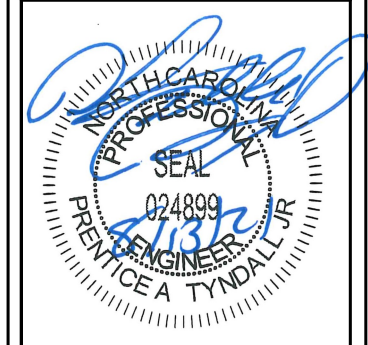

TYNDALL ENGINEERING & DESIGN, P.A.
199 775-1800 • F 919 775-5458
280 Shipwash Drive • Garner • North Carolina • 27839
www.tyndalengineering.com

PLEASANT BUILDERS OF NC, LLC
PERSONAL RESIDENCE

SHEATHING DETAILS

Project #: DRB2101-0126
Date: 08/03/21
Drawn/Design By: KFR / SM
DWG. Checked By: PTH
Scale: NOT TO SCALE

REVISIONS		
No.	Date	Remarks

Sheet Number
D2
5 of 5