

Proposed Residence - Atkins Road

Permit Documents

2021-10-26

GENERAL NOTES

1. THESE ARCHITECTURAL DRAWING REQUIRE COORDINATED STRUCTURAL DRAWINGS. PRIOR TO FRAMING. ALL STRUCTURAL DRAWINGS AND LETTERS ARE TO BE REVIEWED BY THE ARCHITECT PRIOR TO CONSTRUCTION. THESE ARCHITECTURAL DRAWINGS ARE BASED ON FIELD MEASUREMENTS, ACTUAL CONDITIONS MAY VARY. ANY DEVIATION FROM THE DRAWINGS SHALL REQUIRE NOTIFICATION OF THE ARCHITECT.
2. ADJUSTMENTS TO BEARING PLATES AND ROOF SLOPES MAY NEED TO BE MADE TO KEEP FASCIA ALIGNMENTS IN THE FIELD. THE ALIGNMENT OF FASCIAS IN THE ELEVATIONS IF FOR DESIGN INTENT.
3. CONTRACTOR SHALL COMPLY WITH THE NORTH CAROLINA RESIDENTIAL BUILDING CODE 2018.
4. ALL MEMBER SIZES, FOOTINGS, FOUNDATIONS, REINFORCEMENTS, AND ATTACHMENTS ARE FOR DESIGN INTENT ONLY AND SHALL BE ENGINEERED BY STRUCTURAL ENGINEER. IN THE EVENT OF CONFLICTS BETWEEN ENGINEERING AND ARCHITECTURE DRAWINGS, THE ARCHITECT SHALL BE NOTIFIED PRIOR TO CONSTRUCTION.
5. ARCHITECT SHALL BE NOTIFIED OF DIMENSION AND OTHER CONFLICTS WITHIN THE DRAWINGS PROMPTLY AND PRIOR TO CONSTRUCTION.
6. ARCHITECT SHALL BE NOTIFIED OF CLIENT OR CONTRACTOR INITIATED CHANGES TO THESE DOCUMENTS PRIOR TO CONSTRUCTION OF SAID CHANGES.

STRUCTURAL NOTES

1. CONTRACTOR RESPONSIBLE FOR PROVIDING STRUCTURAL DRAWINGS AND SHOP DRAWINGS FOR ARCHITECT AND OWNER FOR REVIEW, REGARDLESS OF PERMIT APPROVAL. STRUCTURAL ENGINEER MUST REVIEW TRUSS AND PRE-ENGINEERED ROOF AND FLOOR SHOP DRAWINGS FOR DESIGN INTENT.
2. IN ANY CASE OF CONFLICT BETWEEN THE NOTES, DETAILS AND SPECIFICATIONS, THE ARCHITECT SHALL BE NOTIFIED CONTRACTOR SHALL MAKE NO DEVIATION FROM CONTRACT DOCUMENTS WITHOUT WRITTEN APPROVAL OF THE ENGINEER AND ARCHITECT.
3. THE CONTRACTOR SHALL VERIFY ALL DIMENSIONS AND CONDITIONS AND COORDINATE WITH ARCHITECTURAL DRAWINGS, DRAWINGS FROM OTHER CONSULTANTS, PROJECT SHOP DRAWINGS AND FIELD CONDITIONS.
4. THE CONTRACTOR SHALL PROTECT EXISTING FACILITIES, STRUCTURES AND UTILITY LINES FROM ALL DAMAGE.



Architect Seal

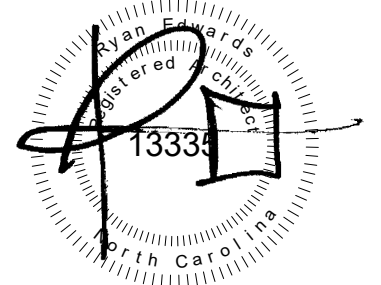

10/26/2021

Firm Seal



Architecture

Company: Filter Design Studio, P.L.L.C.
 Architect: Ryan Edwards
 Address: PO Box 735
 Morehead City, NC 28557
 Phone: 919-422-5598
 Email: ryan@filterdesignstudio.com

Landscape Architecture

Company: Filter Design Studio, P.L.L.C.
 Landscape Architect: Thomas "Jay" Horton
 Address: PO Box 735
 Morehead City, NC 28557
 Phone: 252-230-0788
 Email: jay@filterdesignstudio.com

Proposed Residence

Atkins Road

Fuquay Varina, North Carolina

All drawing and designs are protected by commonlaw copyright and exclusively belong to Filter Design Studio, P.L.L.C. All use, printing, construction and modifications require express permission

CONTACT INFORMATION

ARCHITECT
 FIRM NAME: FILTER DESIGN STUDIO, P.L.L.C.
 CONTACT: RYAN EDWARDS, AIA, NCARB
 EMAIL: RYAN@FILTERDESIGNSTUDIO.COM
 PHONE: (919) 422-5598
 MAIL: 707 BRIDGES STREET
 MOREHEAD CITY, NC 28557

STRUCTURAL ENGINEER

FIRM NAME:
 CONTACT:
 EMAIL:
 PHONE:
 MAIL:

GENERAL CONTRACTOR

FIRM NAME: CUNNINGHAM CONSTRUCTION
 CONTACT: WORTH CUNNINGHAM
 EMAIL: WORTH@CUNNINGHAM-CONSTRUCTION.COM
 PHONE: (252) 726-0066
 MAIL: PO BOX 345
 MOREHEAD CITY, NC 28557

PROPERTY INFORMATION

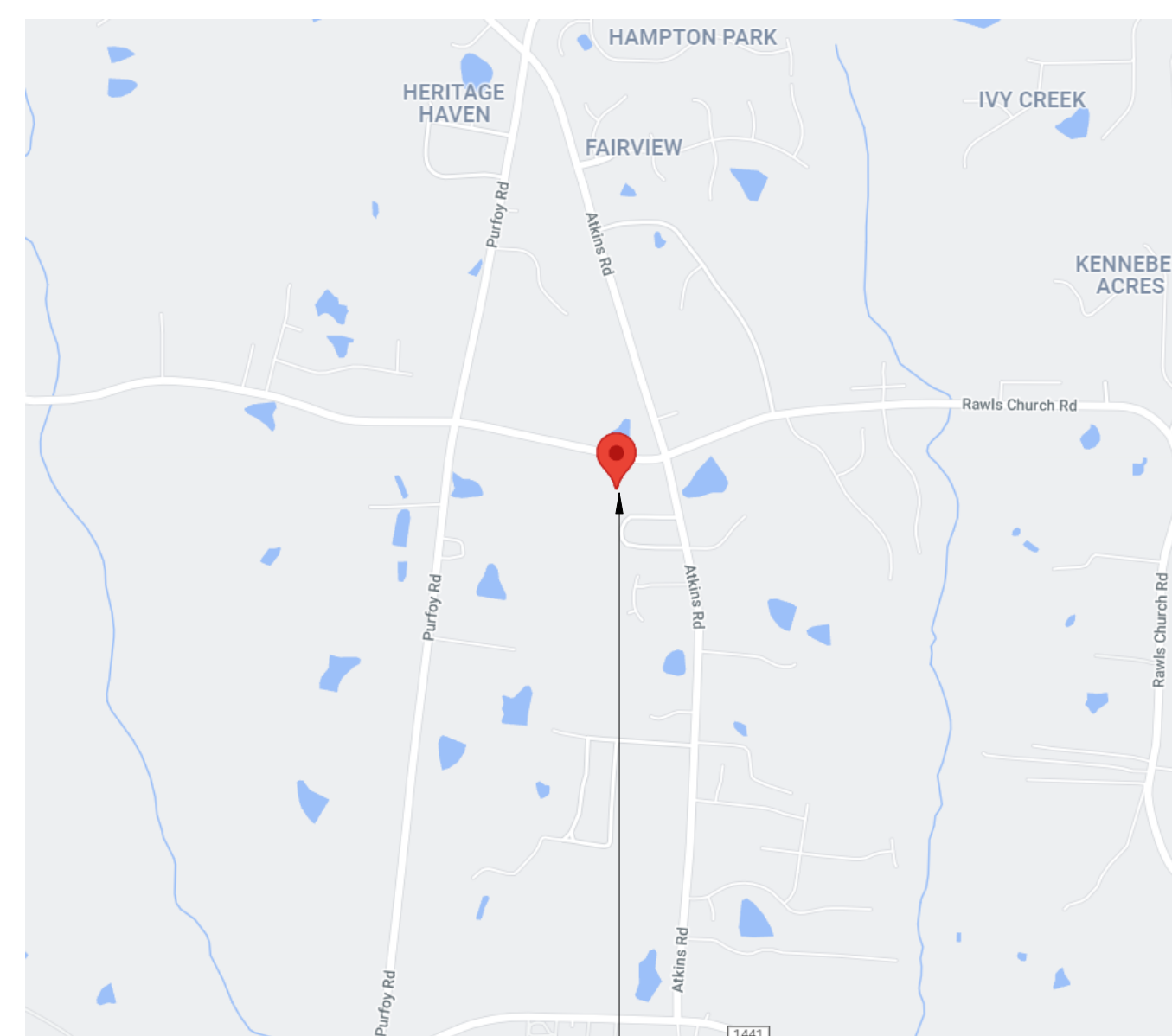

PROJECT LOCATION

PROPERTY MAILING ADDRESS
 UNASSIGNED

PIN
 0664-68-9378.000

PROJECT DESCRIPTION
 CONSTRUCTION OF 2 STORY RESIDENTIAL HOME WITH ATTACHED GARAGE.

Sheet List

Sheet Number	Sheet Name	Sheet Issue Date	Current Revision	Current Revision Date
00 - GENERAL				
G000	Cover	10/26/21		
01 - SITE				
LA100	Site Plan	10/26/21		
02 - ARCHITECTURE				
A100	Architectural Foundation Plan	10/26/21		
A101	1st Floor Plan	10/26/21		
A102	2nd Floor Plan	10/26/21		
A103	Roof Plan	10/26/21		
A201	Exterior Elevations	10/26/21		
A202	Exterior Elevations	10/26/21		
A203	Exterior Elevations	10/26/21		
A301	Building Sections	10/26/21		
A302	Building Sections	10/26/21		
A303	Building Sections	10/26/21		
A304	Building Sections	10/26/21		
A401	Wall Sections	10/26/21		
A402	Wall Sections	10/26/21		
A403	Wall Sections	10/26/21		
A404	Wall Sections	10/26/21		
A501	Details	10/26/21		
A502	Window Details	10/26/21		
A503	Door Details	10/26/21		

Cover

Project number: 21-008
 Date: 10/26/21

G000

Scale: 1/4" = 1'-0"

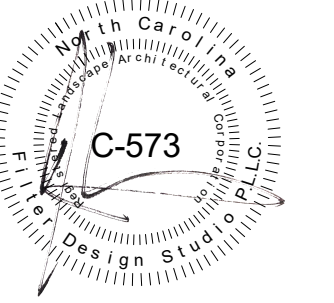

10/26/2021

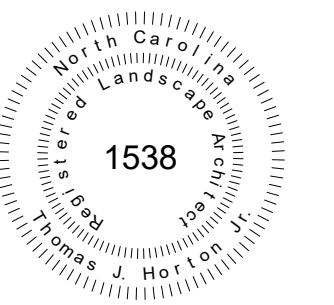

Architecture

Company: Filter Design Studio, P.L.L.C.
Architect: Ryan Edwards
Address: PO Box 735
Morehead City, NC 28557
Phone: 919-422-5598
Email: ryan@filterdesignstudio.com

Landscape Architecture

Company: Filter Design Studio, P.L.L.C.
Landscape Architect: Thomas "Jay" Horton
Address: PO Box 735
Morehead City, NC 28557
Phone: 252-230-0788
Email: jay@filterdesignstudio.com

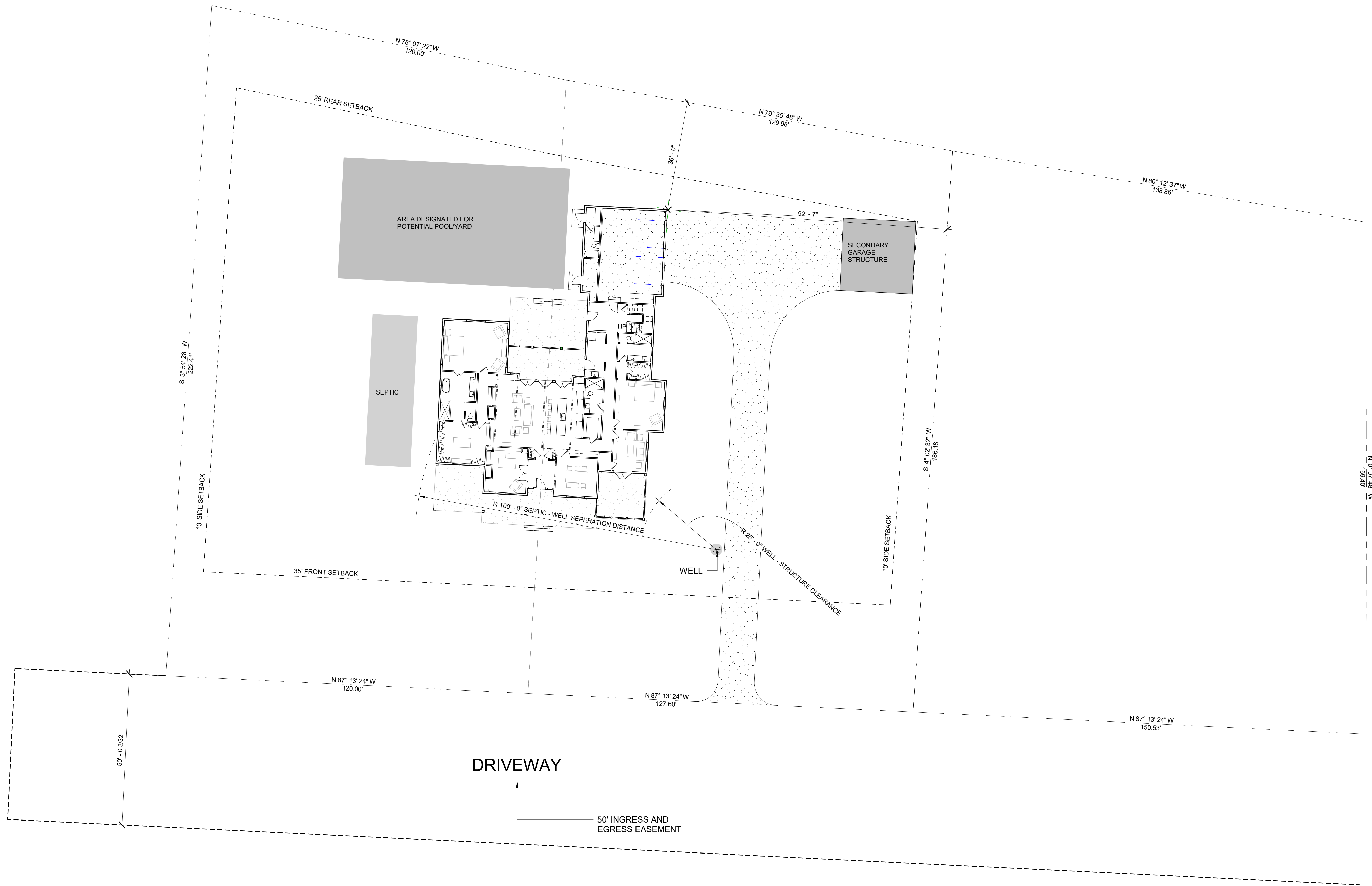

Proposed Residence

Atkins Road
Fuquay Varina, North Carolina

All drawing and designs are protected by commonlaw copyright and exclusively belong to Filter Design Studio, P.L.L.C. All use, printing, construction and modifications require express permission

No.	Description	Date

Site Plan

Project number 21-008
Date 10/26/21

LA100

Scale 1/16" = 1'-0"



TRUE NORTH

Architect Seal

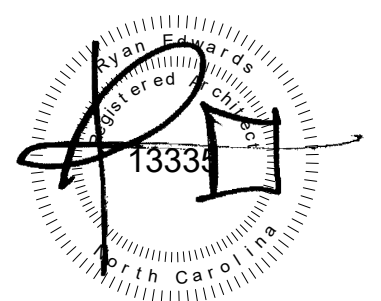

10/26/2021

Firm Seal

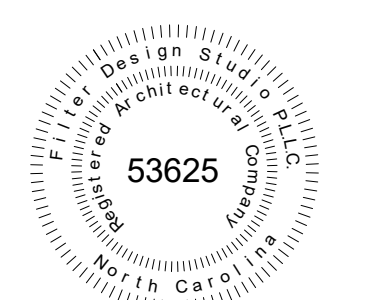

Architecture

Company: Filter Design Studio, P.L.L.C.
Architect: Ryan Edwards
Address: PO Box 735
Morehead City, NC 28557
Phone: 919-422-5598
Email: ryan@filterdesignstudio.com

Landscape Architecture

Company: Filter Design Studio, P.L.L.C.
Landscape Architect: Thomas "Jay" Horton
Address: PO Box 735
Morehead City, NC 28557
Phone: 252-230-0788
Email: jay@filterdesignstudio.com

Proposed Residence

Atkins Road
Fuquay Varina, North Carolina

All drawing and designs are protected by commonlaw copyright and exclusively belong to Filter Design Studio, P.L.L.C. All use, printing, construction and modifications require express permission

No.	Description	Date

Architectural
Foundation Plan

Project number 21-008
Date 10/26/21

A100

Scale 1/4" = 1'-0"

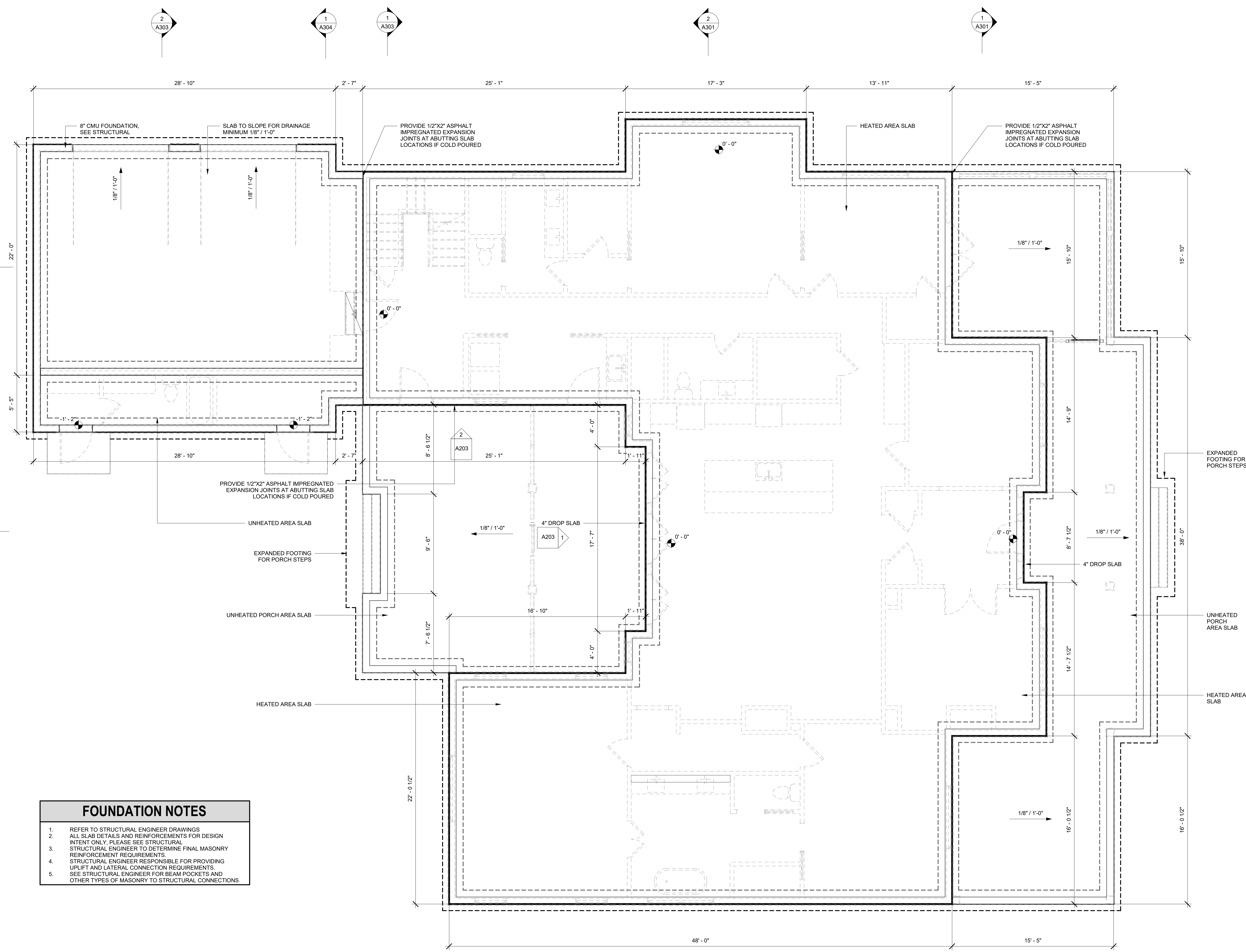

FOUNDATION NOTES

1. REFER TO STRUCTURAL ENGINEER DRAWINGS
2. ALL SLAB DETAILS AND REINFORCEMENTS FOR DESIGN INTENT ONLY, PLEASE SEE STRUCTURAL
3. STRUCTURAL ENGINEER TO DETERMINE FINAL MASONRY REINFORCEMENT REQUIREMENTS.
4. STRUCTURAL ENGINEER RESPONSIBLE FOR PROVIDING UPLIFT AND LATERAL CONNECTION REQUIREMENTS.
5. SEE STRUCTURAL ENGINEER FOR BEAM POCKETS AND OTHER TYPES OF MASONRY TO STRUCTURAL CONNECTIONS

Architect Seal

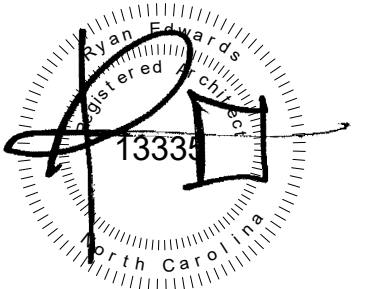

10/26/2021

Firm Seal

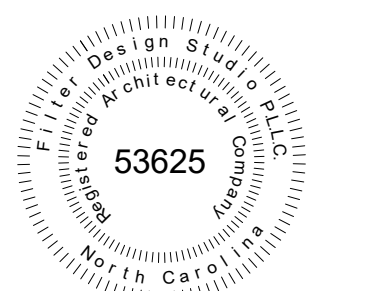

Architecture

Company: Filter Design Studio, P.L.L.C.
Architect: Ryan Edwards
Address: PO Box 735
Morehead City, NC 28557
Phone: 919-422-5598
Email: ryan@filterdesignstudio.com

Landscape Architecture

Company: Filter Design Studio, P.L.L.C.
Landscape Architect: Thomas "Jay" Horton
Address: PO Box 735
Morehead City, NC 28557
Phone: 252-230-0788
Email: jay@filterdesignstudio.com

Proposed Residence

Atkins Road
Fuquay Varina, North Carolina

All drawing and designs are protected by commonlaw copyright and exclusively belong to Filter Design Studio, P.L.L.C. All use, printing, construction and modifications require express permission

No.	Description	Date

1st Floor Plan

Project number: 21-008
Date: 10/26/21

A101

Scale: 1/4" = 1'-0"

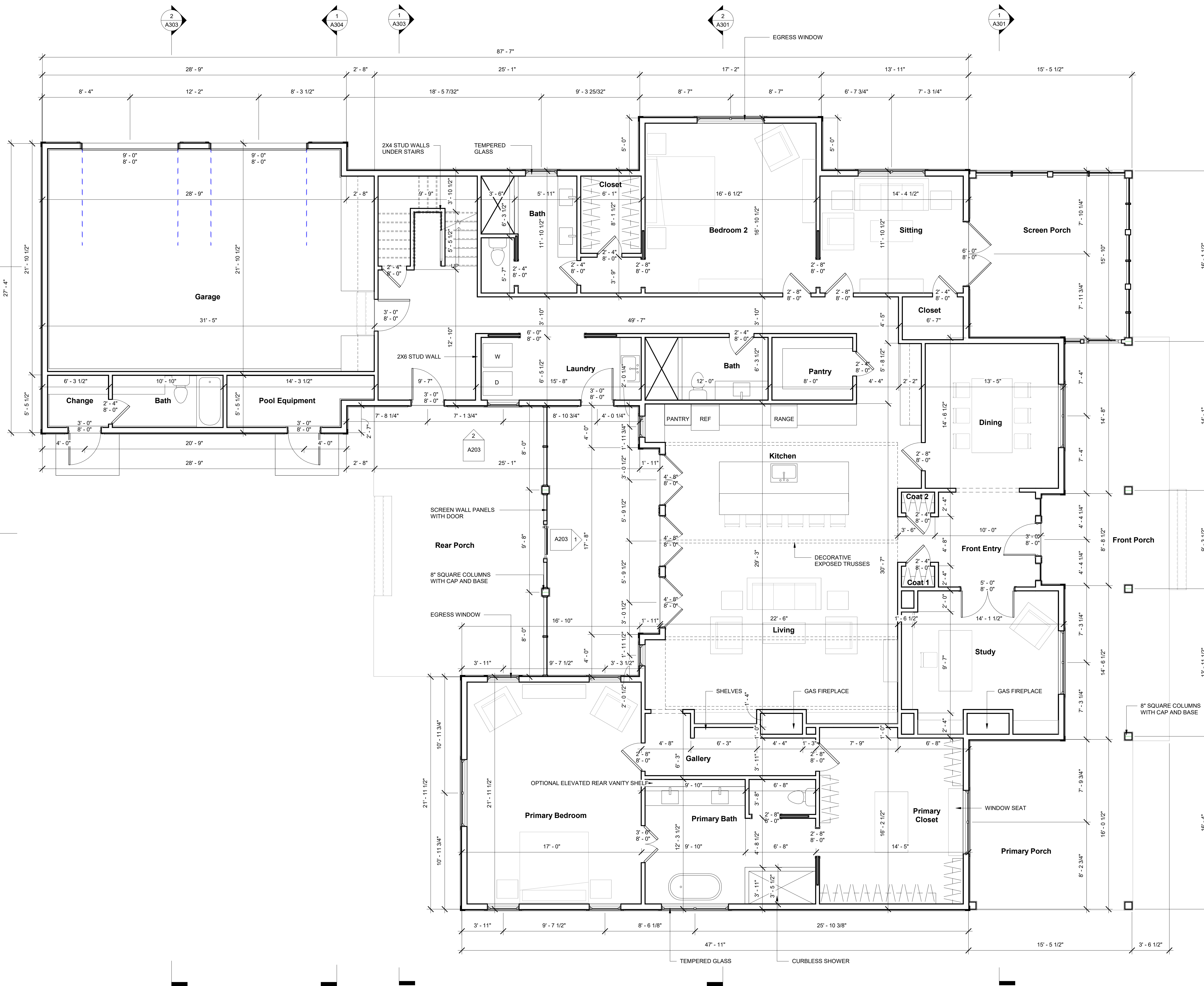

Architect Seal

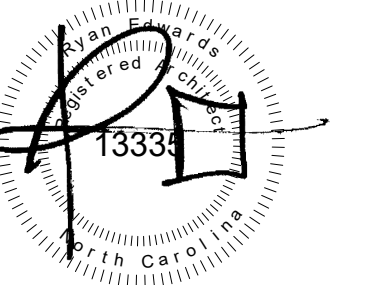

10/26/2021

Firm Seal

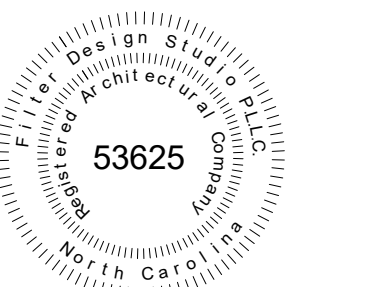

Architecture

Company: Filter Design Studio, P.L.L.C.
Architect: Ryan Edwards
Address: PO Box 735
Morehead City, NC 28557
Phone: 919-422-5598
Email: ryan@filterdesignstudio.com

Landscape Architecture

Company: Filter Design Studio, P.L.L.C.
Landscape Architect: Thomas "Jay" Horton
Address: PO Box 735
Morehead City, NC 28557
Phone: 252-230-0788
Email: jay@filterdesignstudio.com

Proposed Residence

Atkins Road
Fuquay Varina, North Carolina

All drawing and designs are protected by commonlaw copyright and exclusively belong to Filter Design Studio, P.L.L.C. All use, printing, construction and modifications require express permission

No.	Description	Date

2nd Floor Plan

Project number 21-008
Date 10/26/21

A102

Scale 1/4" = 1'-0"

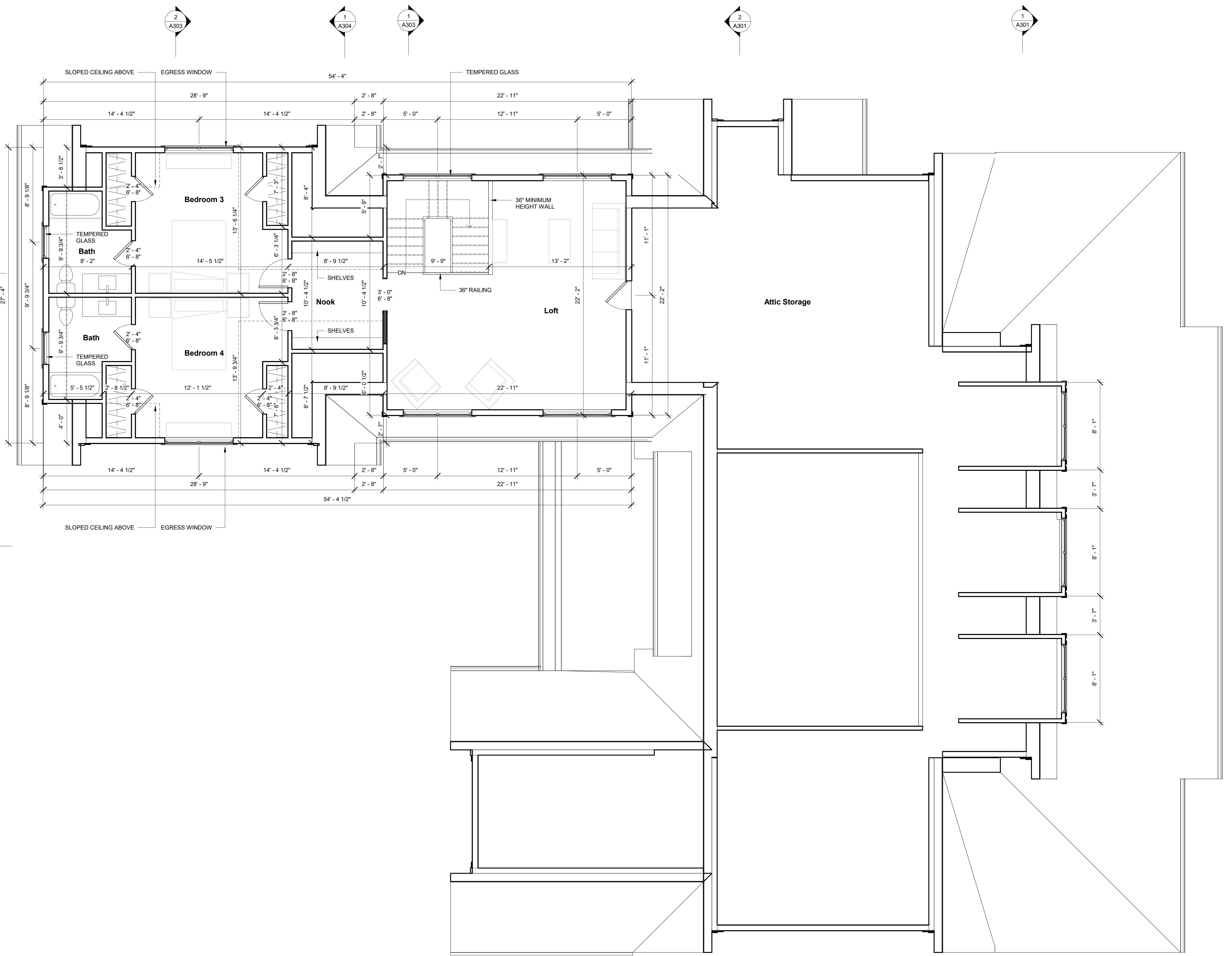

Architect Seal

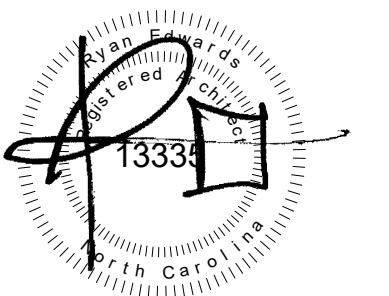

10/26/2021

Firm Seal

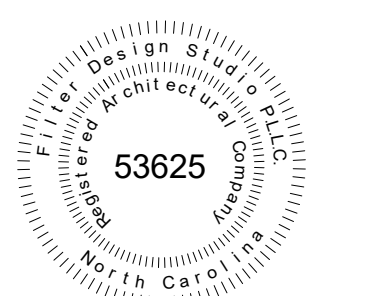

Architecture

Company: Filter Design Studio, P.L.L.C.
Architect: Ryan Edwards
Address: PO Box 735
Morehead City, NC 28557
Phone: 919-422-5598
Email: ryan@filterdesignstudio.com

Landscape Architecture

Company: Filter Design Studio, P.L.L.C.
Landscape Architect: Thomas "Jay" Horton
Address: PO Box 735
Morehead City, NC 28557
Phone: 252-230-0788
Email: jay@filterdesignstudio.com

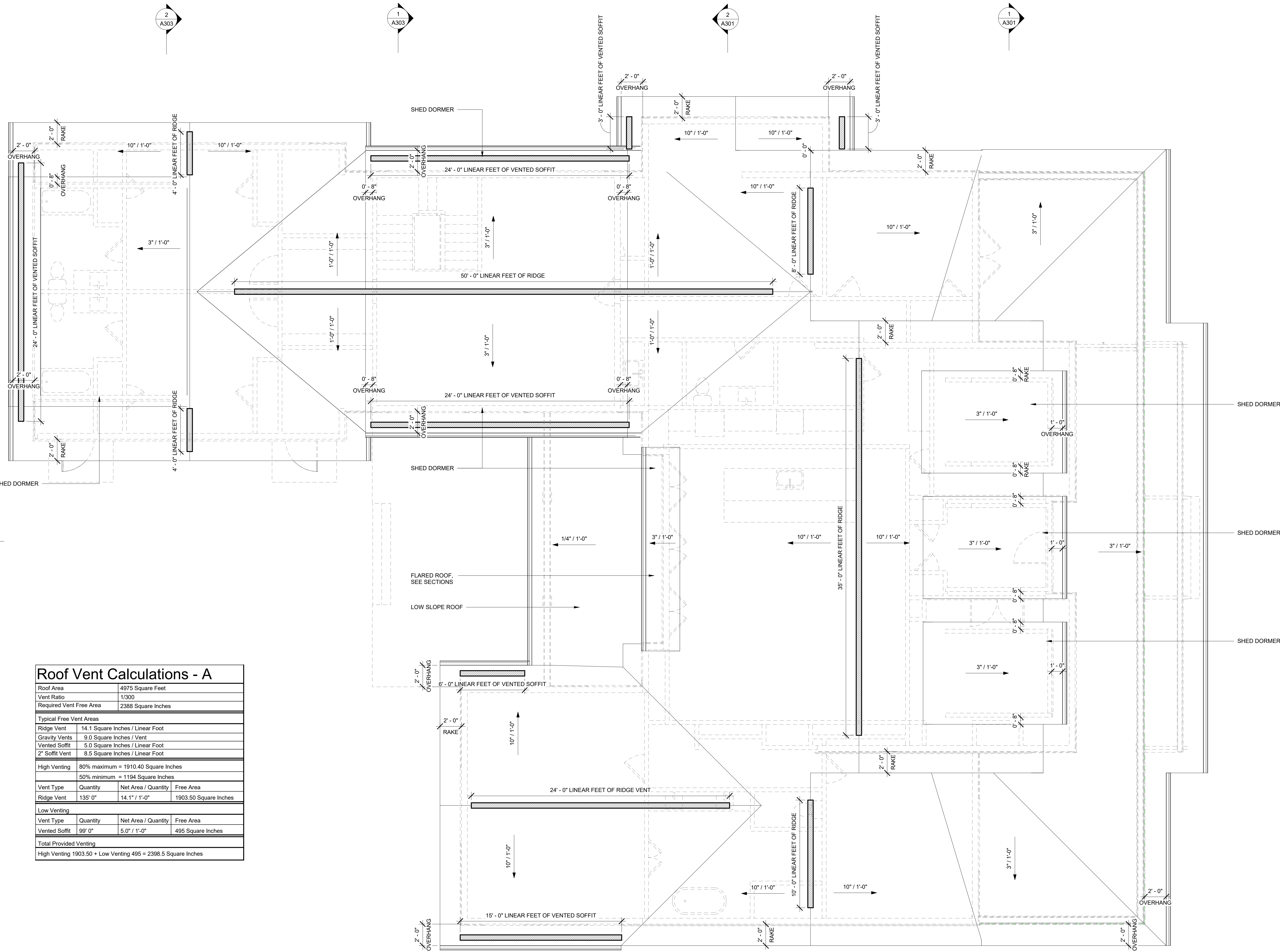

Roof Vent Calculations - A

Roof Area	4975 Square Feet		
Vent Ratio	1/300		
Required Vent Free Area	2388 Square Inches		
Typical Free Vent Areas			
Ridge Vent	14.1 Square Inches / Linear Foot		
Gravity Vents	9.0 Square Inches / Vent		
Vented Soffit	5.0 Square Inches / Linear Foot		
2" Soffit Vent	8.5 Square Inches / Linear Foot		
High Venting			
	80% maximum = 1910.40 Square Inches		
	50% minimum = 1194 Square Inches		
Vent Type	Quantity	Net Area / Quantity	Free Area
Ridge Vent	135' 0"	14.1" / 1'-0"	1903.50 Square Inches
Low Venting			
Vent Type	Quantity	Net Area / Quantity	Free Area
Vented Soffit	99' 0"	5.0" / 1'-0"	495 Square Inches
Total Provided Venting			
High Venting 1903.50 + Low Venting 495 = 2398.5 Square Inches			

Proposed Residence

Atkins Road
Fuquay Varina, North Carolina

All drawing and designs are protected by commonlaw copyright and exclusively belong to Filter Design Studio, P.L.L.C. All use, printing, construction and modifications require express permission

No.	Description	Date

Roof Plan

Project number 21-008
Date 10/26/21

A103

Scale 1/4" = 1'-0"

Architect Seal

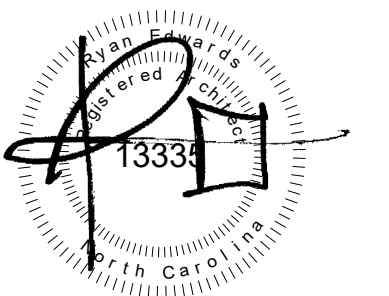

10/26/2021

Firm Seal

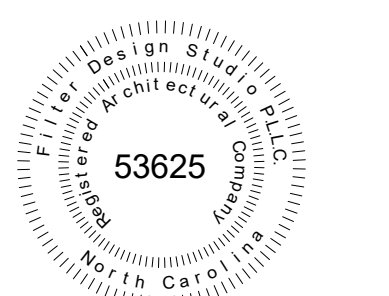

Architecture
Company: Filter Design Studio, P.L.L.C.
Architect: Ryan Edwards
Address: PO Box 735, Morehead City, NC 28557
Phone: 919-422-5598
Email: ryan@filterdesignstudio.com

Landscape Architecture
Company: Filter Design Studio, P.L.L.C.
Landscape Architect: Thomas "Jay" Horton
Address: PO Box 735, Morehead City, NC 28557
Phone: 252-230-0788
Email: jay@filterdesignstudio.com

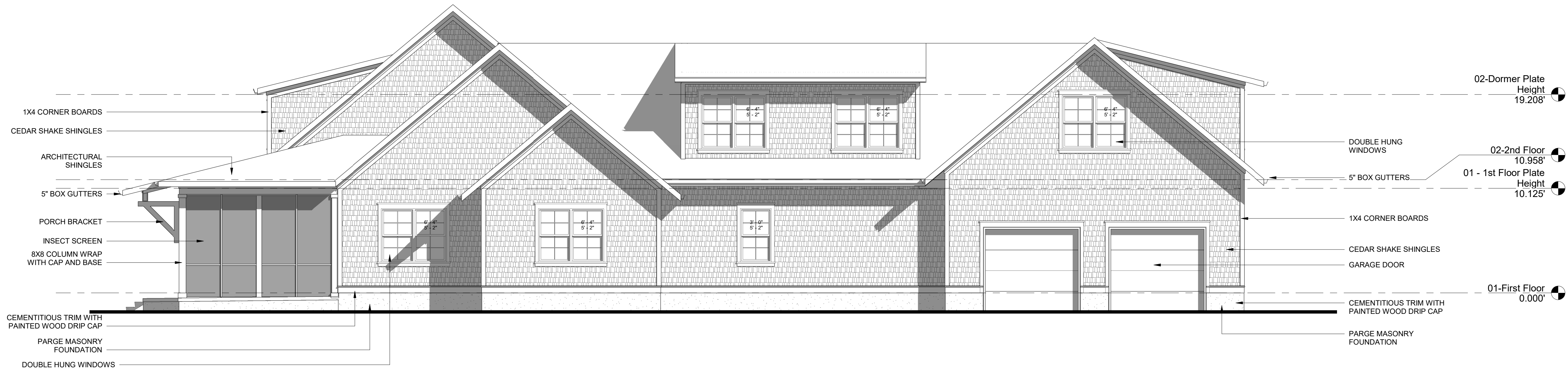

Proposed Residence
Atkins Road
Fuquay Varina, North Carolina

All drawing and designs are protected by commonlaw copyright and exclusively belong to Filter Design Studio, P.L.L.C. All use, printing, construction and modifications require express permission

No.	Description	Date

Exterior Elevations

Project number: 21-008
Date: 10/26/21

A201

Scale: 3/16" = 1'-0"

Architect Seal

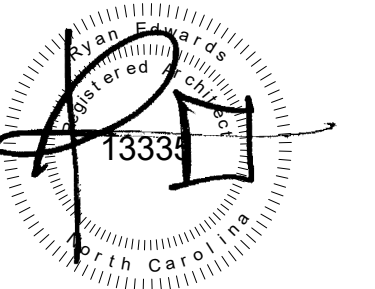

10/26/2021

Firm Seal

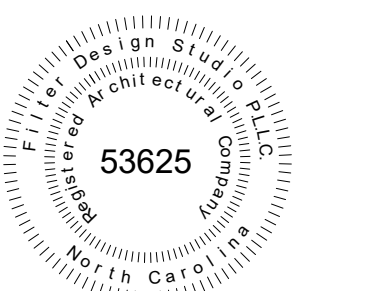

Architecture

Company: Filter Design Studio, P.L.L.C.
Architect: Ryan Edwards
Address: PO Box 735
Morehead City, NC 28557
Phone: 919-422-5598
Email: ryan@filterdesignstudio.com

Landscape Architecture

Company: Filter Design Studio, P.L.L.C.
Landscape Architect: Thomas "Jay" Horton
Address: PO Box 735
Morehead City, NC 28557
Phone: 252-230-0788
Email: jay@filterdesignstudio.com

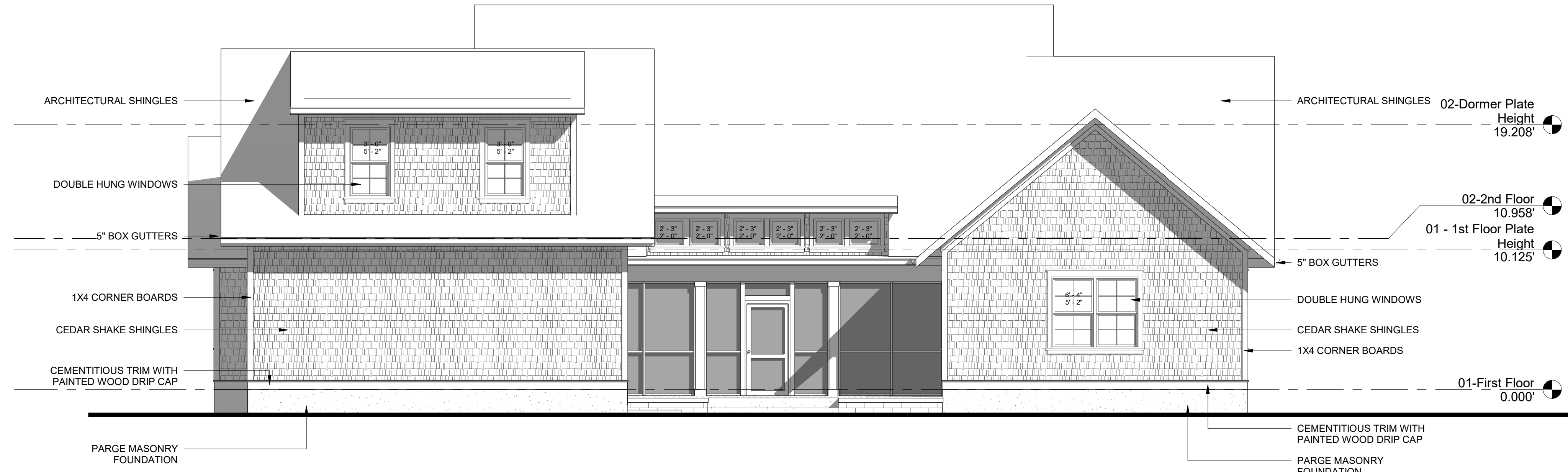

Proposed Residence

Atkins Road
Fuquay Varina, North Carolina

All drawing and designs are protected by commonlaw copyright and exclusively belong to Filter Design Studio, P.L.L.C. All use, printing, construction and modifications require express permission

No.	Description	Date

Exterior Elevations

Project number 21-008
Date 10/26/21

A202

Scale 3/16" = 1'-0"

Architect Seal

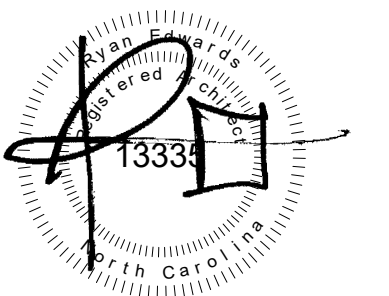

10/26/2021

Firm Seal

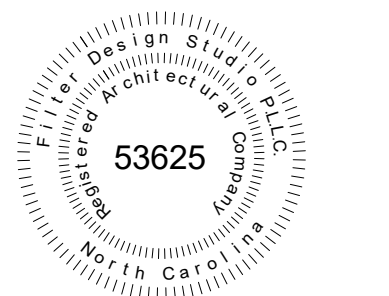

Architecture

Company: Filter Design Studio, P.L.L.C.
Architect: Ryan Edwards
Address: PO Box 735
Morehead City, NC 28557
Phone: 919-422-5598
Email: ryan@filterdesignstudio.com

Landscape Architecture

Company: Filter Design Studio, P.L.L.C.
Landscape Architect: Thomas "Jay" Horton
Address: PO Box 735
Morehead City, NC 28557
Phone: 252-230-0788
Email: jay@filterdesignstudio.com



2 | Garage Rear Elevation
3/16" = 1'-0"

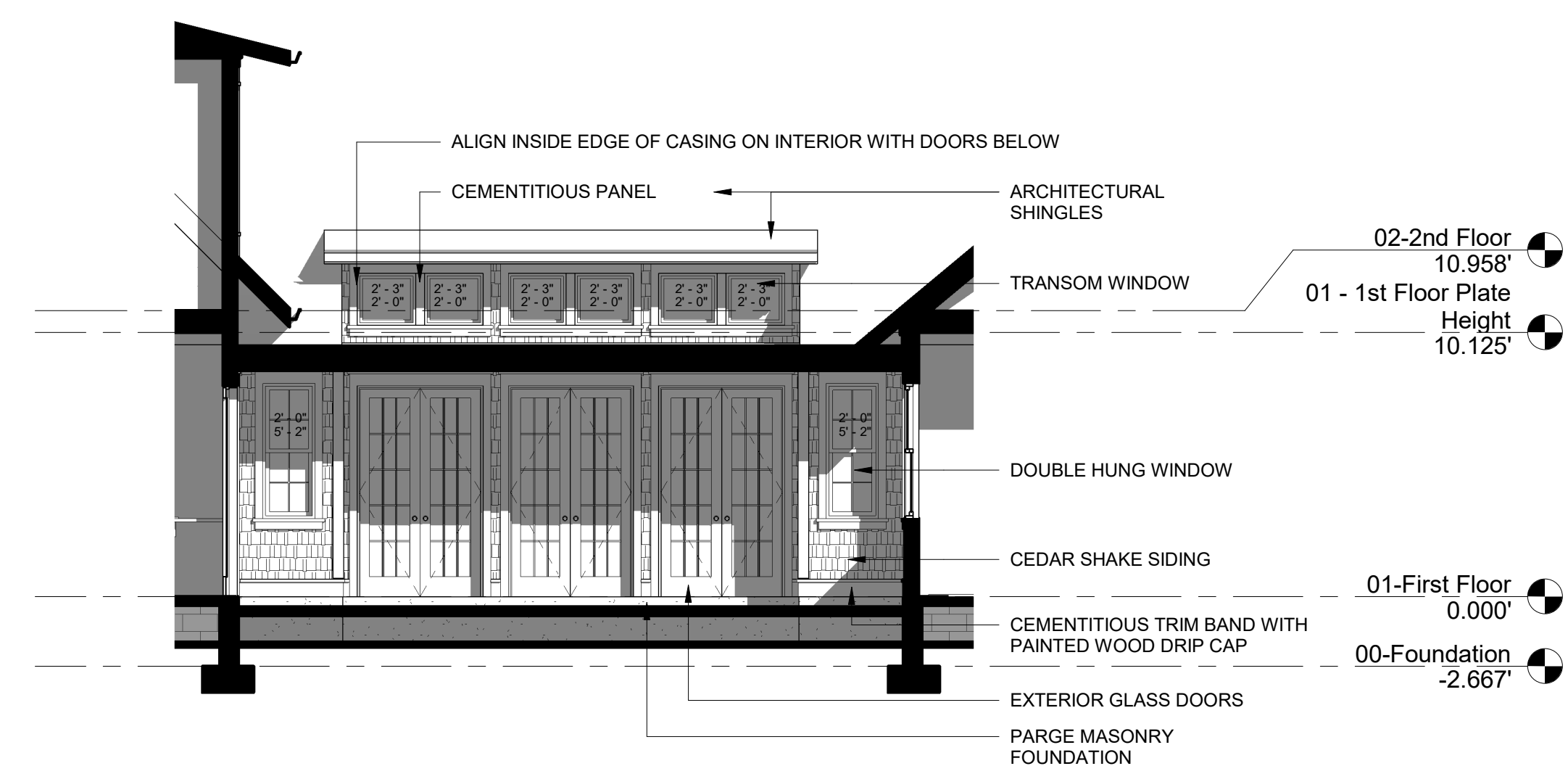

1 | Rear Porch Elevation
3/16" = 1'-0"

Proposed Residence

Atkins Road
Fuquay Varina, North Carolina

All drawing and designs are protected by commonlaw copyright and exclusively belong to Filter Design Studio, P.L.L.C. All use, printing, construction and modifications require express permission

No.	Description	Date

Exterior Elevations	
Project number	21-008
Date	10/26/21
A203	
Scale	3/16" = 1'-0"

Architect Seal

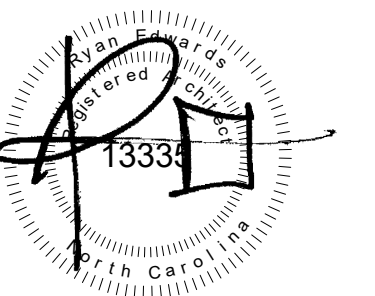

10/26/2021

Firm Seal

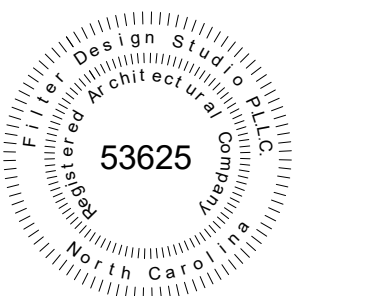

Architecture

Company: Filter Design Studio, P.L.L.C.
Architect: Ryan Edwards
Address: PO Box 735
Morehead City, NC 28557
Phone: 919-422-5598
Email: ryan@filterdesignstudio.com

Landscape Architecture

Company: Filter Design Studio, P.L.L.C.
Landscape Architect: Thomas "Jay" Horton
Address: PO Box 735
Morehead City, NC 28557
Phone: 252-230-0788
Email: jay@filterdesignstudio.com

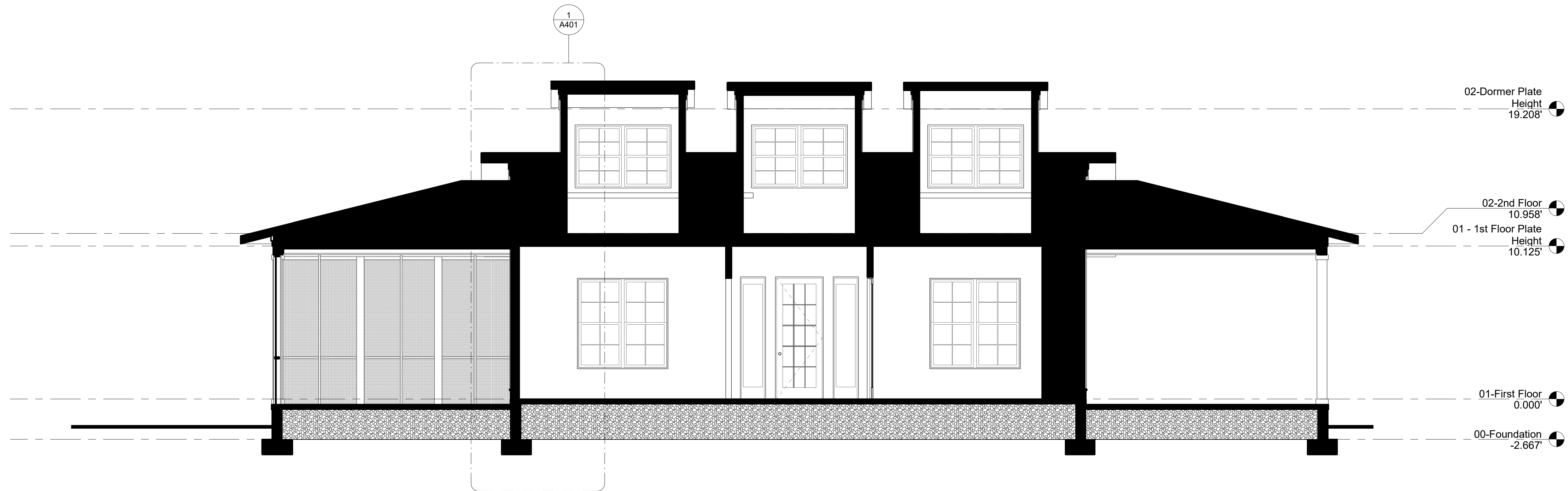

1 Building Section - Entry
1/4" = 1'-0"

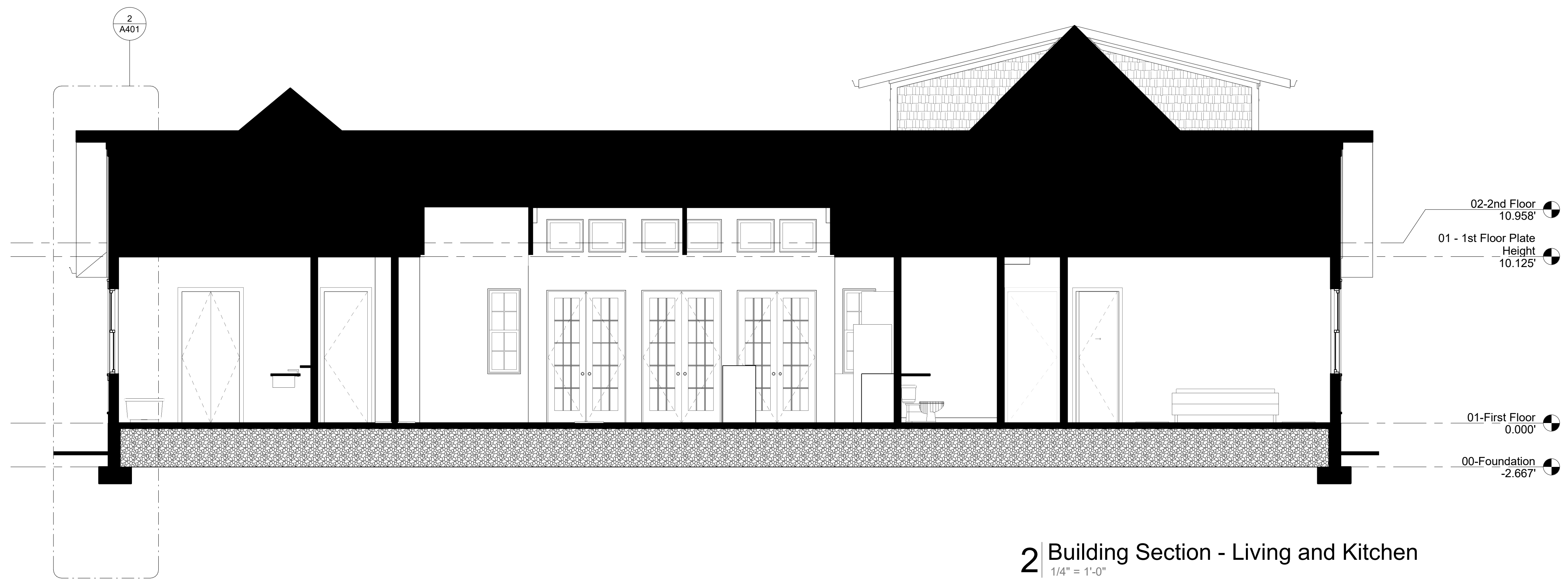

2 Building Section - Living and Kitchen
1/4" = 1'-0"

Proposed Residence

Atkins Road
Fuquay Varina, North Carolina

All drawing and designs are protected by commonlaw copyright and exclusively belong to Filter Design Studio, P.L.L.C. All use, printing, construction and modifications require express permission

No.	Description	Date

Building Sections	
Project number	21-008
Date	10/26/21
A301	
Scale	1/4" = 1'-0"

Architect Seal

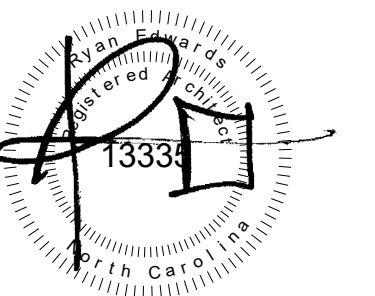

10/26/2021

Firm Seal



Architecture

Company: Filter Design Studio, P.L.L.C.
Architect: Ryan Edwards
Address: PO Box 735
Morehead City, NC 28557
Phone: 919-422-5598
Email: ryan@filterdesignstudio.com

Landscape Architecture

Company: Filter Design Studio, P.L.L.C.
Landscape Architect: Thomas "Jay" Horton
Address: PO Box 735
Morehead City, NC 28557
Phone: 252-230-0788
Email: jay@filterdesignstudio.com

Proposed Residence

Atkins Road
Fuquay Varina, North Carolina

All drawing and designs are protected by commonlaw copyright and exclusively belong to Filter Design Studio, P.L.L.C. All use, printing, construction and modifications require express permission

No.	Description	Date

Building Sections

Project number: 21-008
Date: 10/26/21

A302

Scale: 1/4" = 1'-0"

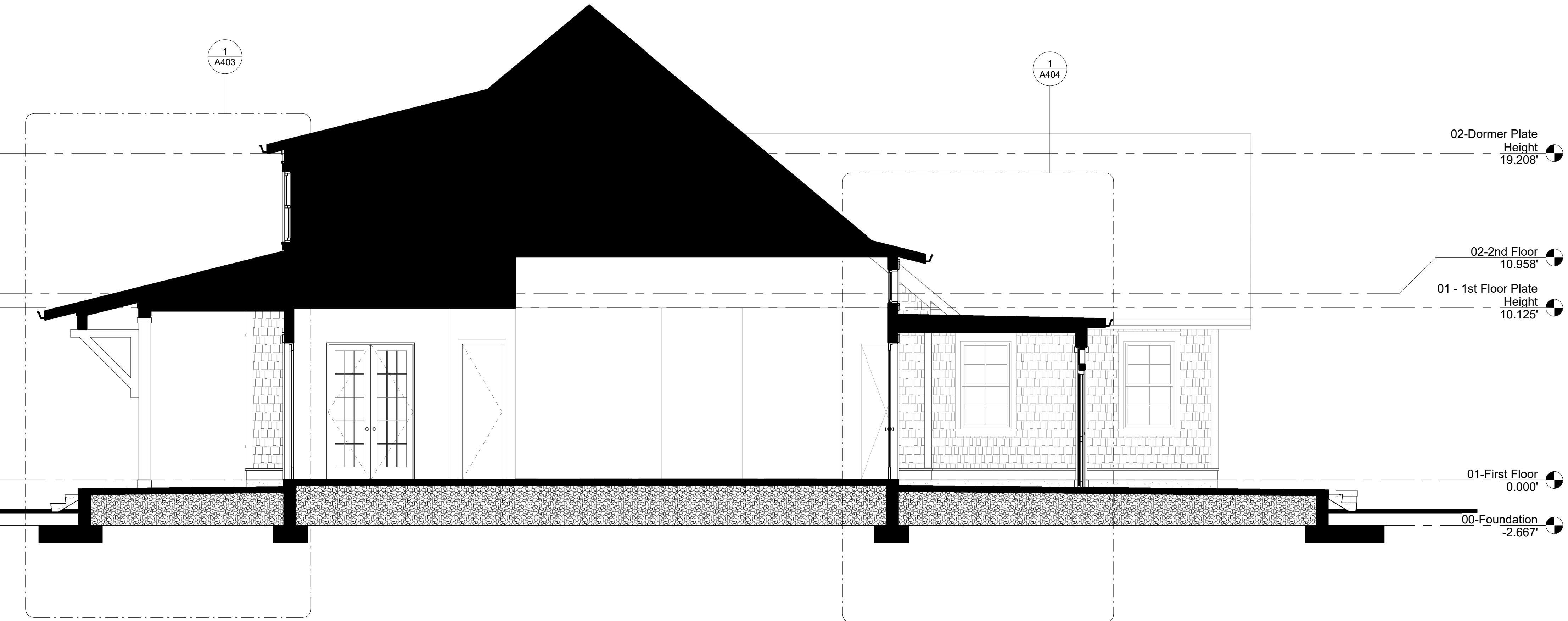

Architect Seal

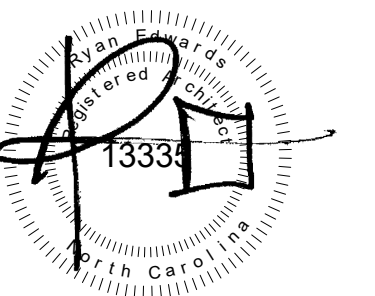

10/26/2021

Firm Seal



Architecture

Company: Filter Design Studio, P.L.L.C.
Architect: Ryan Edwards
Address: PO Box 735
Morehead City, NC 28557
Phone: 919-422-5598
Email: ryan@filterdesignstudio.com

Landscape Architecture

Company: Filter Design Studio, P.L.L.C.
Landscape Architect: Thomas "Jay" Horton
Address: PO Box 735
Morehead City, NC 28557
Phone: 252-230-0788
Email: jay@filterdesignstudio.com

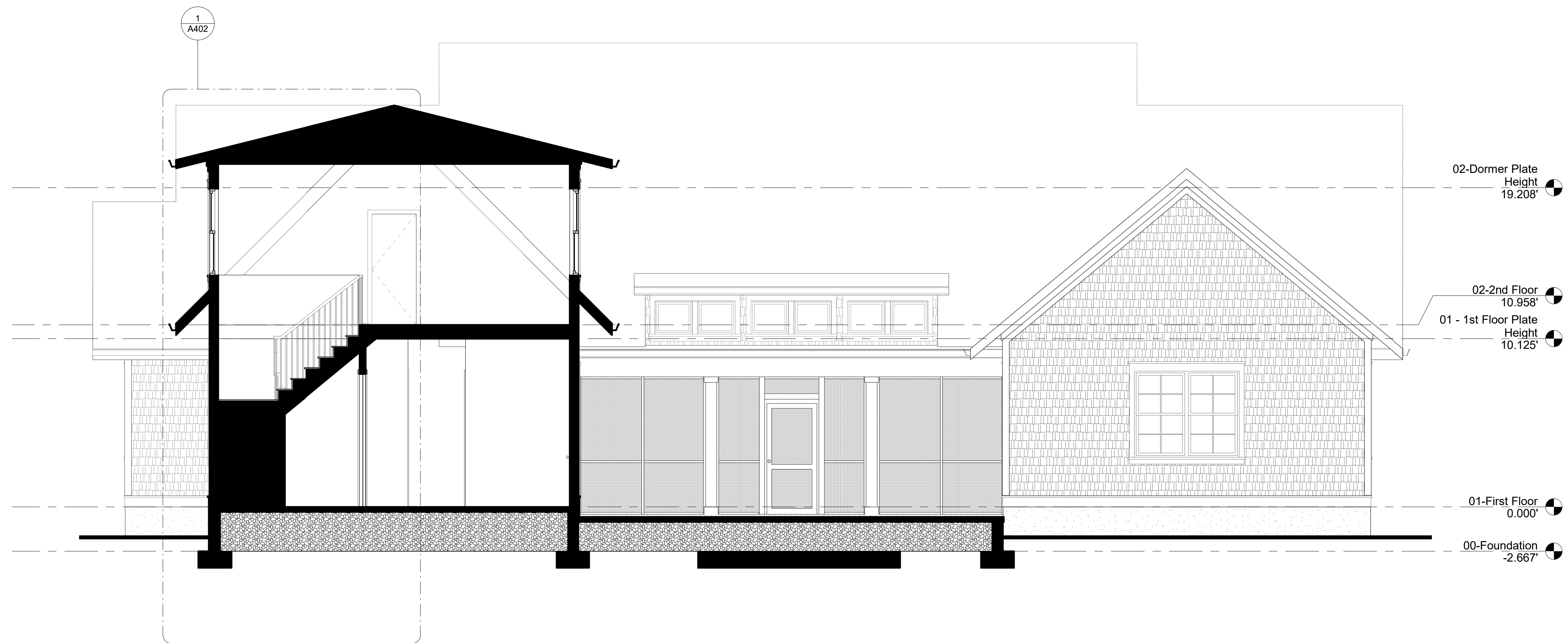

Proposed Residence

Atkins Road
Fuquay Varina, North Carolina

All drawing and designs are protected by commonlaw copyright and exclusively belong to Filter Design Studio, P.L.L.C. All use, printing, construction and modifications require express permission

No.	Description	Date

Building Sections

Project number 21-008
Date 10/26/21

A303

Scale 1/4" = 1'-0"

Architect Seal

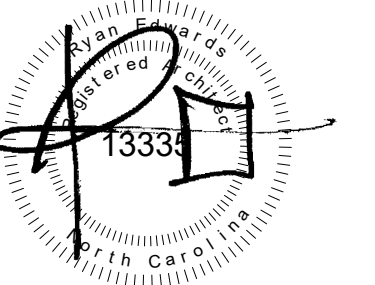

10/26/2021

Firm Seal

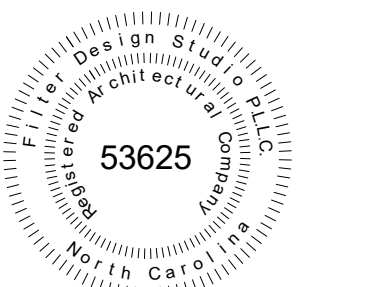

Architecture

Company: Filter Design Studio, P.L.L.C.
Architect: Ryan Edwards
Address: PO Box 735
Morehead City, NC 28557
Phone: 919-422-5598
Email: ryan@filterdesignstudio.com

Landscape Architecture

Company: Filter Design Studio, P.L.L.C.
Landscape Architect: Thomas "Jay" Horton
Address: PO Box 735
Morehead City, NC 28557
Phone: 252-230-0788
Email: jay@filterdesignstudio.com

Proposed Residence

Atkins Road
Fuquay Varina, North Carolina

All drawing and designs are protected by commonlaw copyright and exclusively belong to Filter Design Studio, P.L.L.C. All use, printing, construction and modifications require express permission

No.	Description	Date

Wall Sections

Project number 21-008
Date 10/26/21

A401

Scale 3/4" = 1'-0"

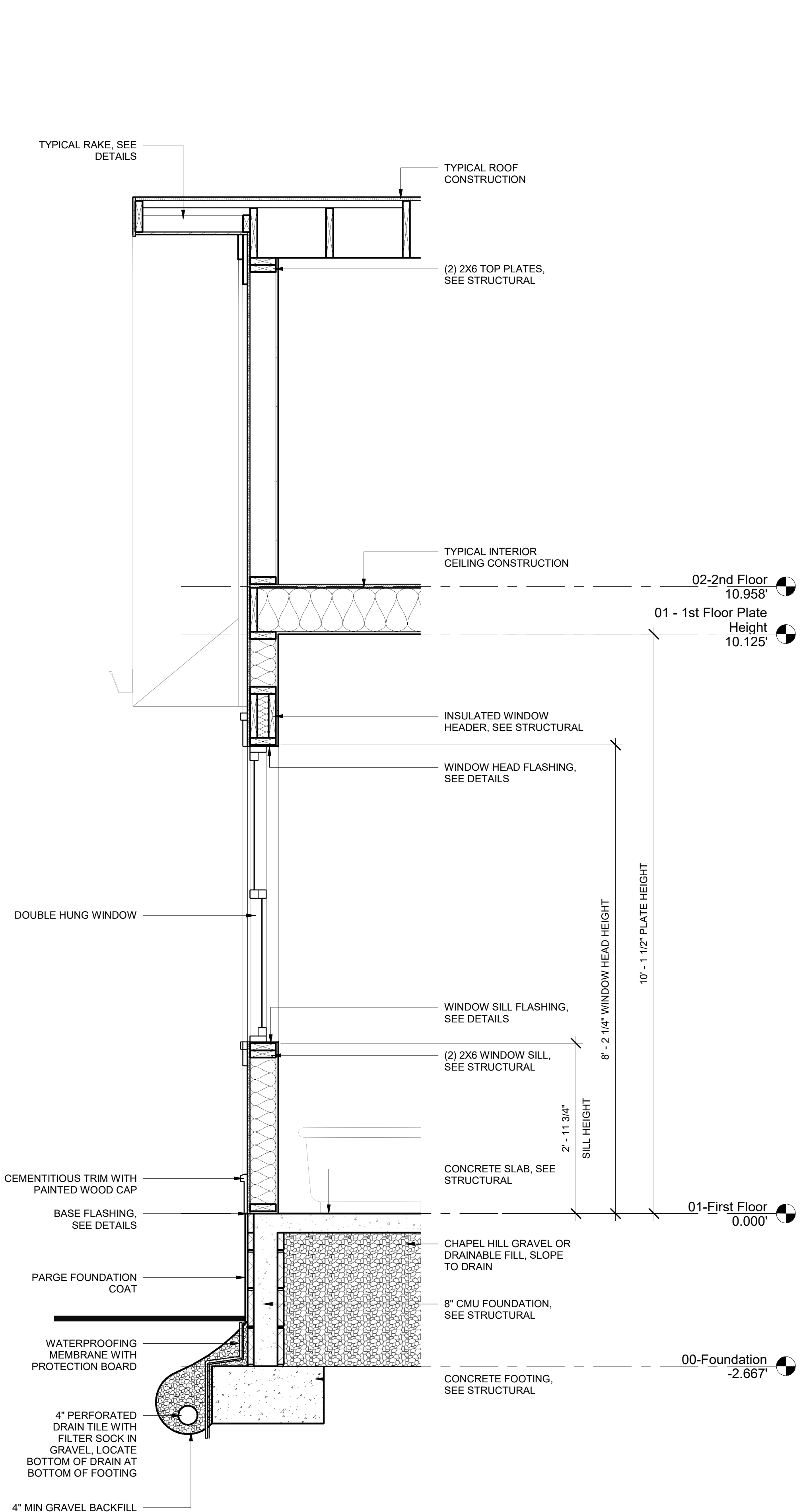

2 Wall Section - Typical Wall
3/4" = 1'-0"

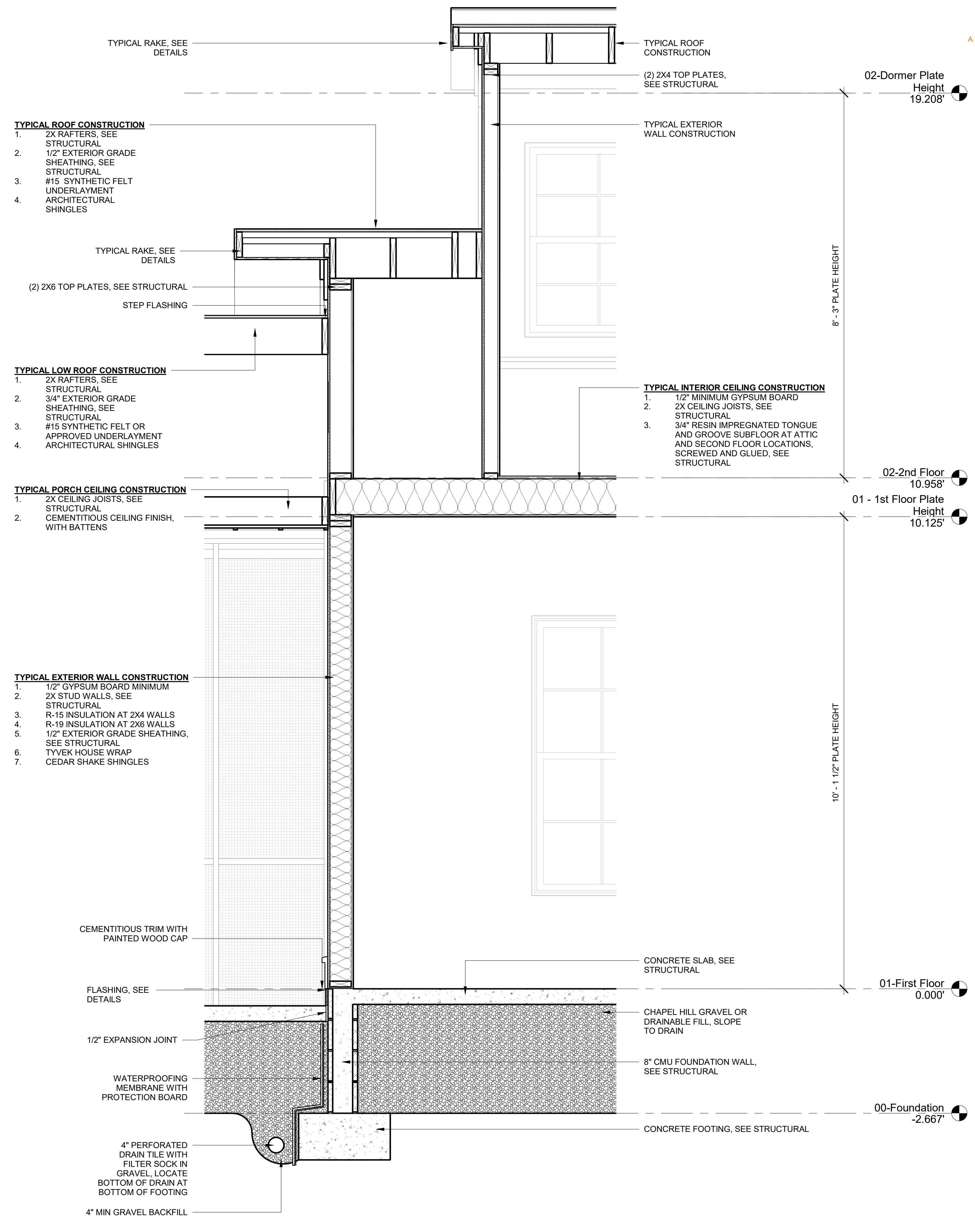

1 Wall Section - Dormer
3/4" = 1'-0"

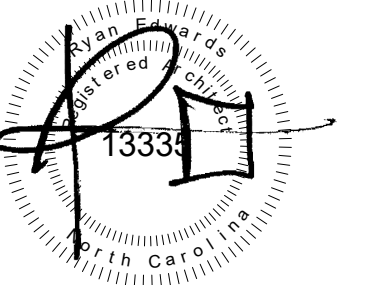

10/26/2021

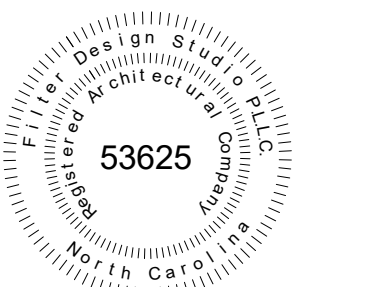

Architecture

Company: Filter Design Studio, P.L.L.C.
Architect: Ryan Edwards
Address: PO Box 735
Morehead City, NC 28557
Phone: 919-422-5598
Email: ryan@filterdesignstudio.com

Landscape Architecture

Company: Filter Design Studio, P.L.L.C.
Landscape Architect: Thomas "Jay" Horton
Address: PO Box 735
Morehead City, NC 28557
Phone: 252-230-0788
Email: jay@filterdesignstudio.com

Proposed Residence

Atkins Road
Fuquay Varina, North Carolina

All drawing and designs are protected by commonlaw copyright and exclusively belong to Filter Design Studio, P.L.L.C. All use, printing, construction and modifications require express permission

No.	Description	Date

Wall Sections

Project number 21-008
Date 10/26/21

A402

Scale 3/4" = 1'-0"

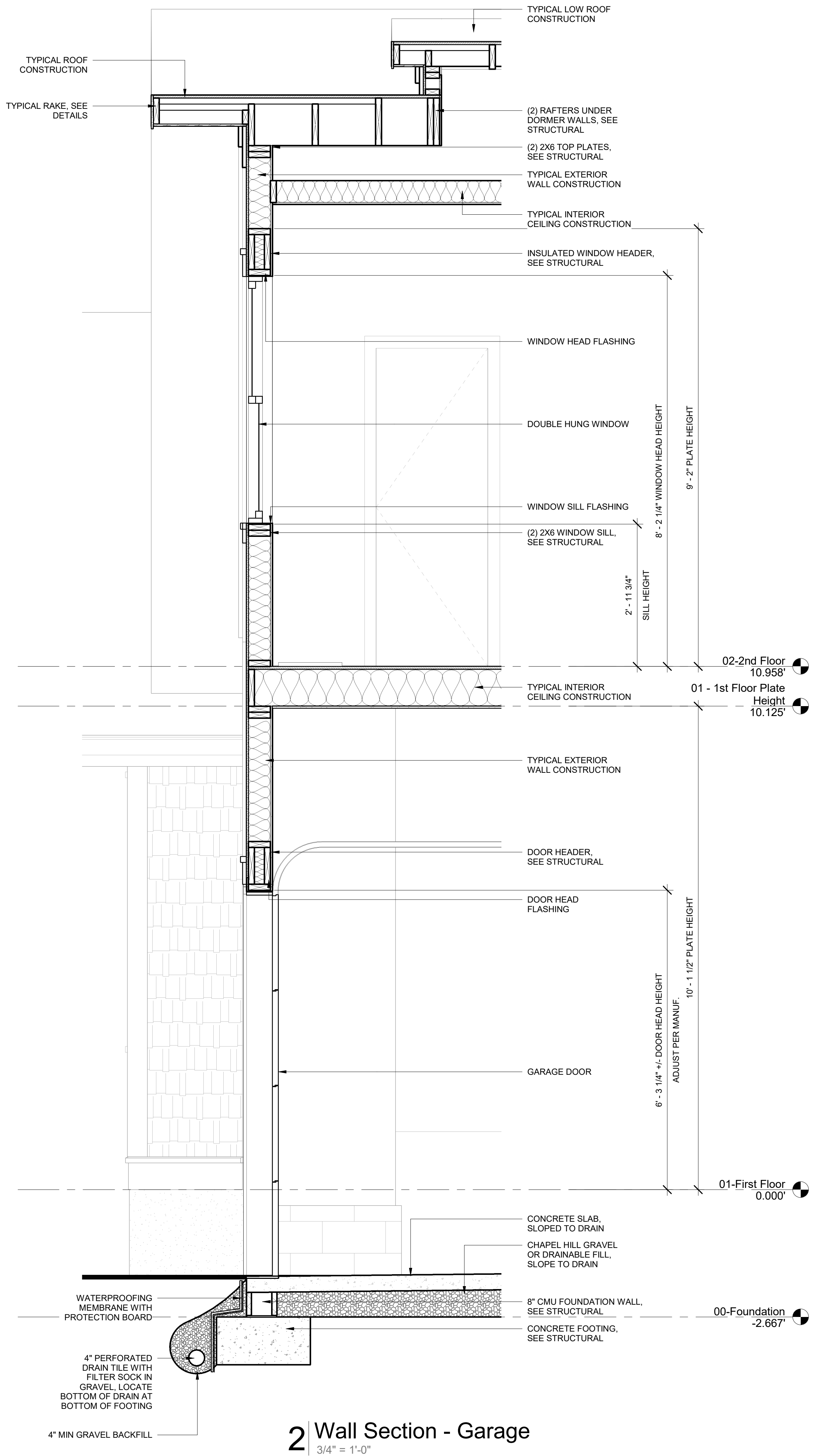

2 Wall Section - Garage
3/4" = 1'-0"

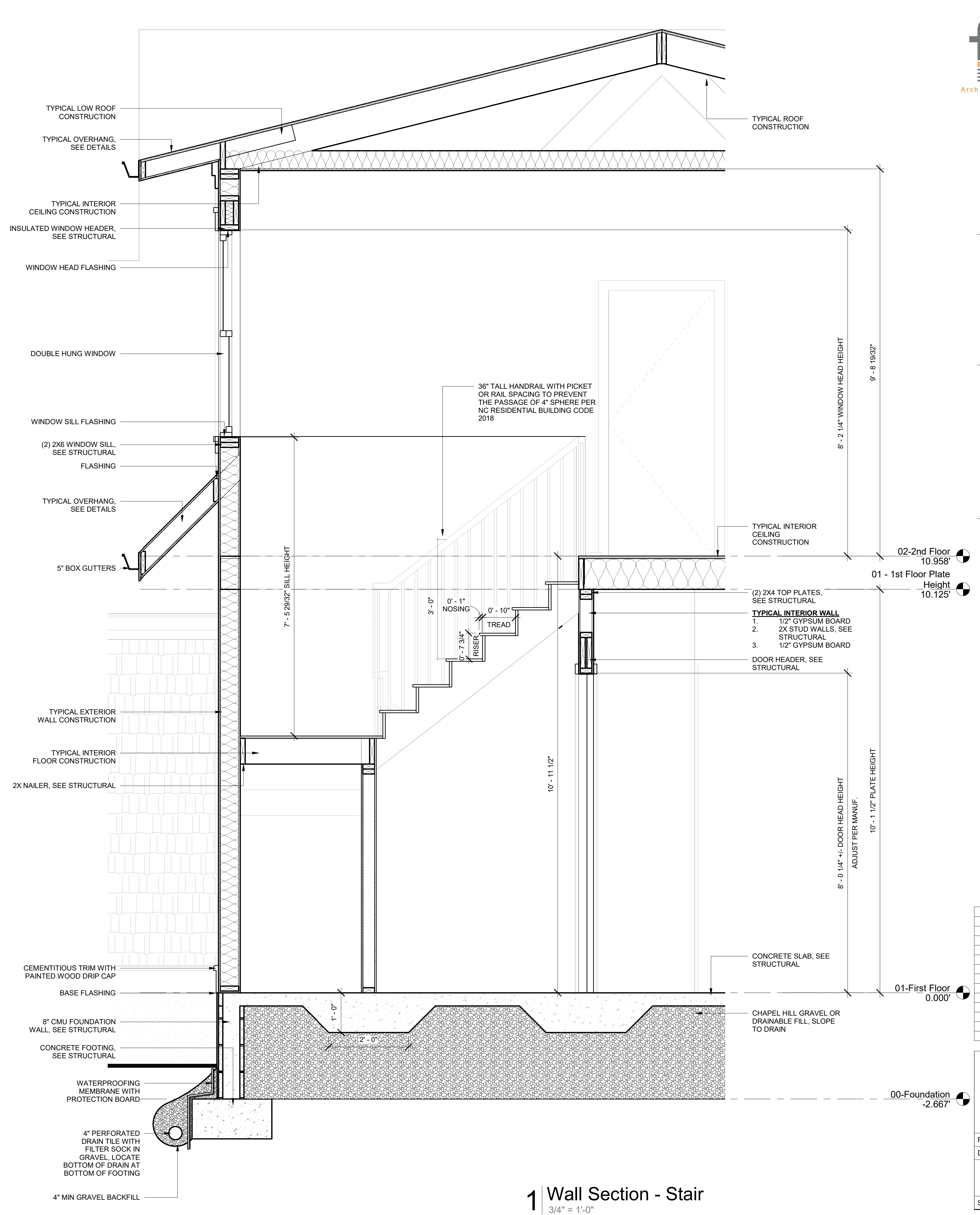

1 Wall Section - Stair
3/4" = 1'-0"

Architect Seal

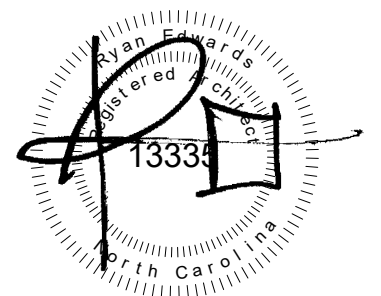

10/26/2021

Firm Seal



Architecture

Company: Filter Design Studio, P.L.L.C.
Architect: Ryan Edwards
Address: PO Box 735
Morehead City, NC 28557
Phone: 919-422-5598
Email: ryan@filterdesignstudio.com

Landscape Architecture

Company: Filter Design Studio, P.L.L.C.
Landscape Architect: Thomas "Jay" Horton
Address: PO Box 735
Morehead City, NC 28557
Phone: 252-230-0788
Email: jay@filterdesignstudio.com

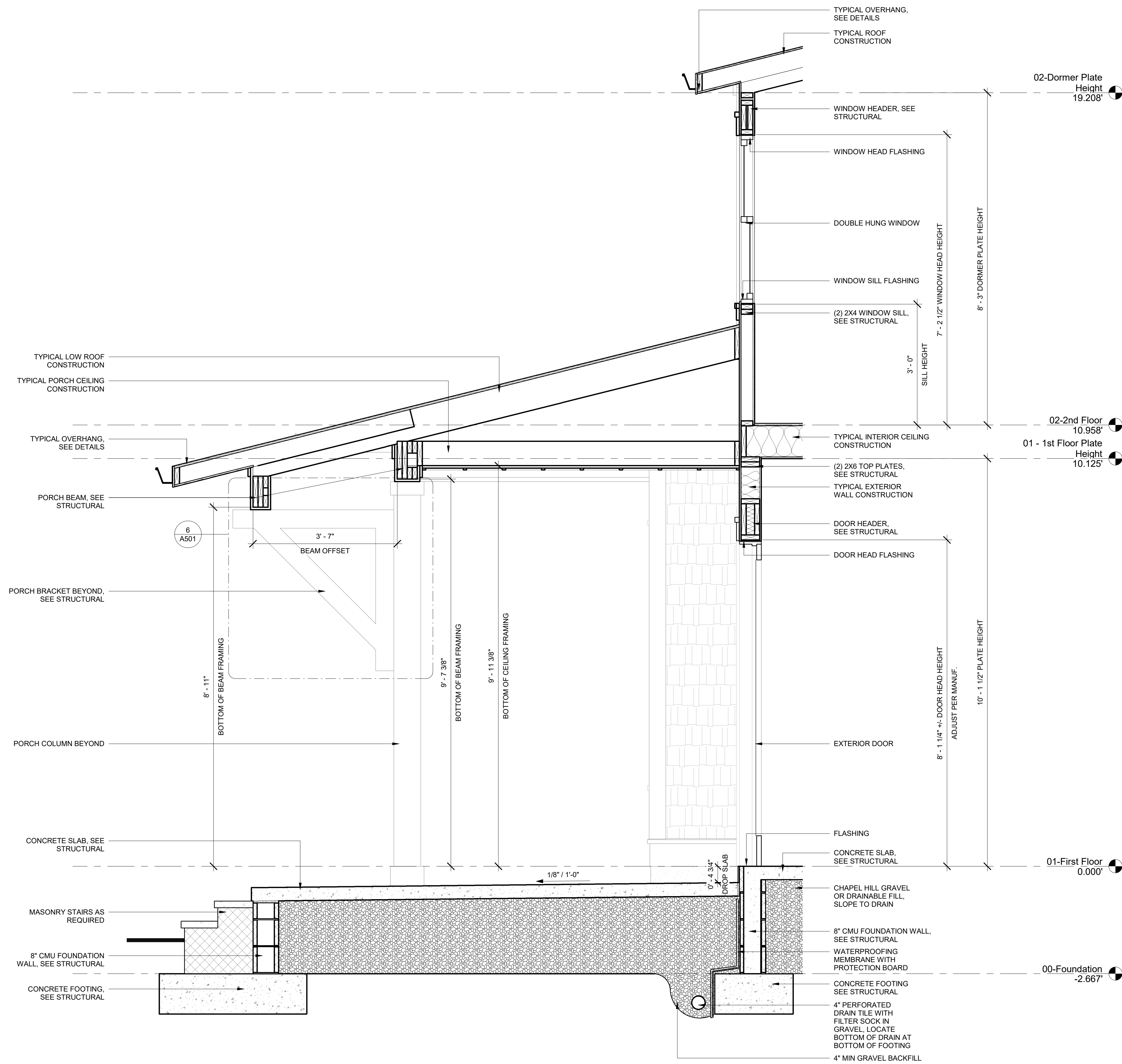

Proposed Residence

Atkins Road
Fuquay Varina, North Carolina

All drawing and designs are protected by commonlaw copyright and exclusively belong to Filter Design Studio, P.L.L.C. All use, printing, construction and modifications require express permission

No.	Description	Date

Wall Sections

Project number: 21-008
Date: 10/26/21

A403

Scale: 3/4" = 1'-0"

Architect Seal

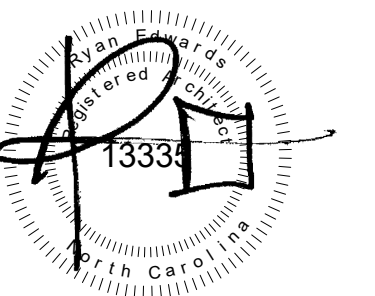

10/26/2021

Firm Seal

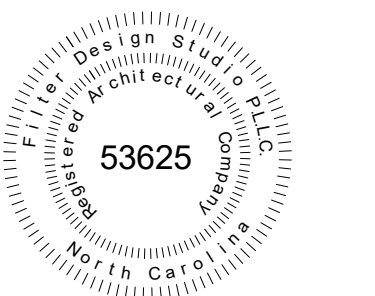

Architecture

Company: Filter Design Studio, P.L.L.C.
Architect: Ryan Edwards
Address: PO Box 735
Morehead City, NC 28557
Phone: 919-422-5598
Email: ryan@filterdesignstudio.com

Landscape Architecture

Company: Filter Design Studio, P.L.L.C.
Landscape Architect: Thomas "Jay" Horton
Address: PO Box 735
Morehead City, NC 28557
Phone: 252-230-0788
Email: jay@filterdesignstudio.com

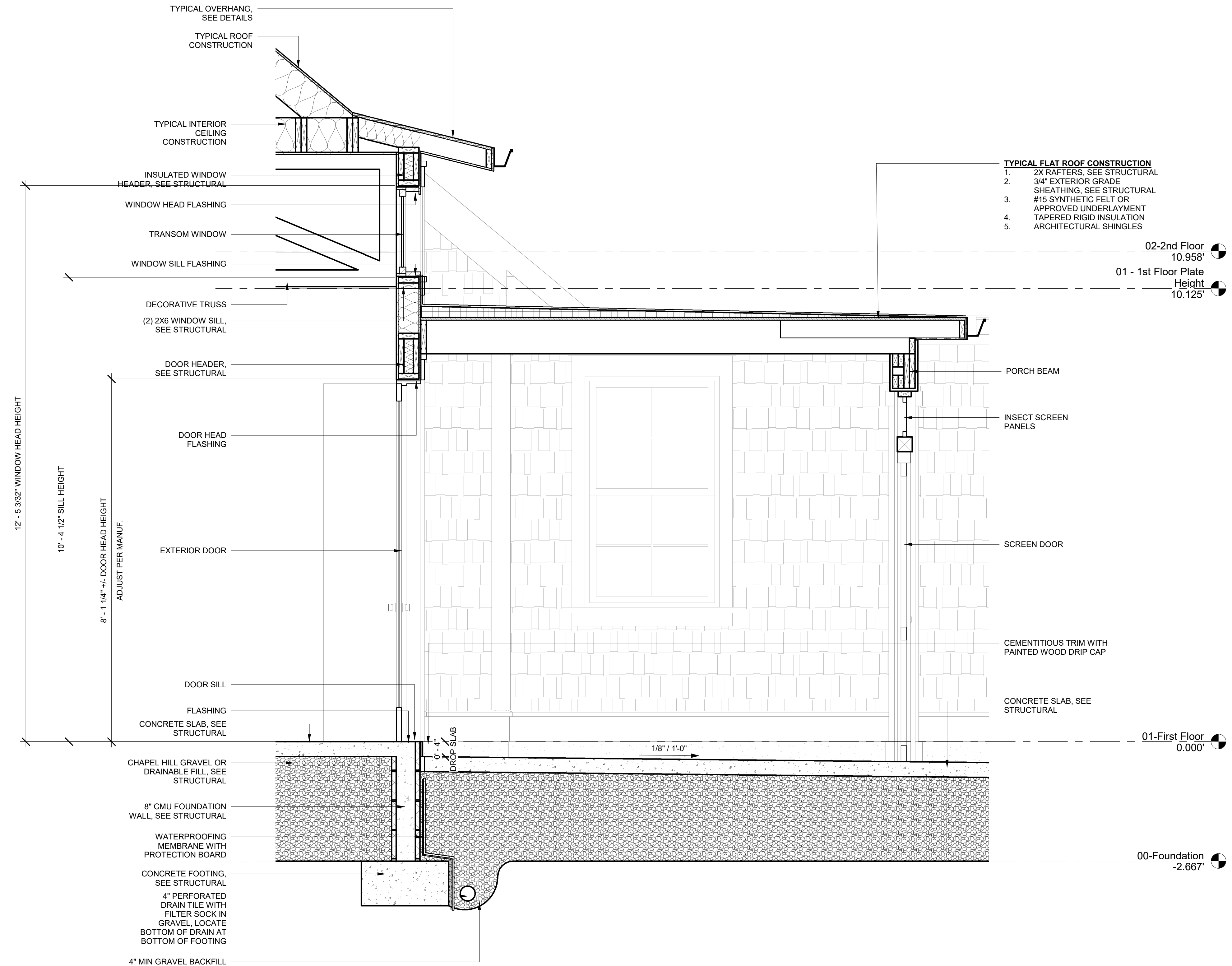

Proposed Residence

Atkins Road
Fuquay Varina, North Carolina

All drawing and designs are protected by commonlaw copyright and exclusively belong to Filter Design Studio, P.L.L.C. All use, printing, construction and modifications require express permission

No.	Description	Date

Wall Sections

Project number 21-008
Date 10/26/21

A404

Scale 3/4" = 1'-0"

Architect Seal

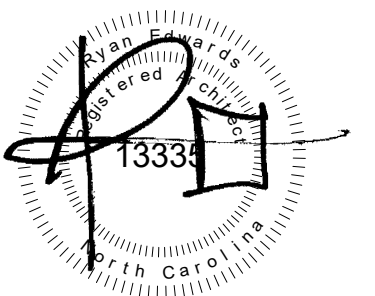

10/26/2021

Firm Seal

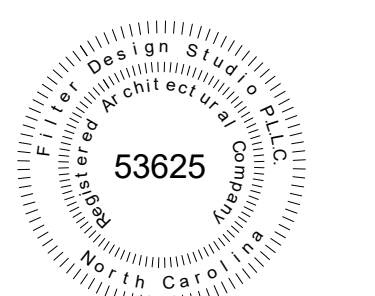

Architecture

Company: Filter Design Studio, P.L.L.C.
Architect: Ryan Edwards
Address: PO Box 735
Morehead City, NC 28557
Phone: 919-422-5598
Email: ryan@filterdesignstudio.com

Landscape Architecture

Company: Filter Design Studio, P.L.L.C.
Landscape Architect: Thomas "Jay" Horton
Address: PO Box 735
Morehead City, NC 28557
Phone: 252-230-0788
Email: jay@filterdesignstudio.com

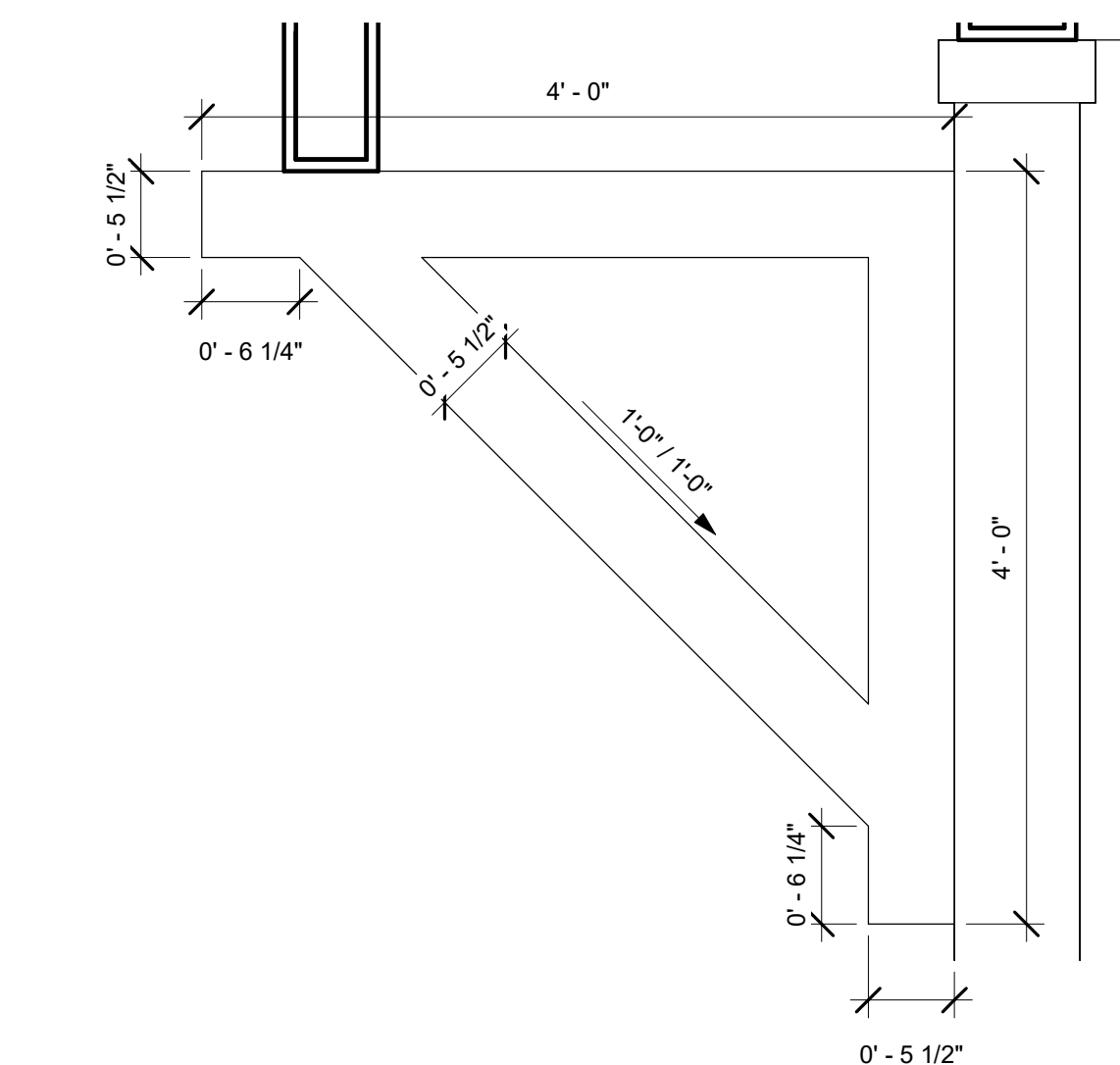

6 Detail - Porch Bracket
1" = 1'-0"

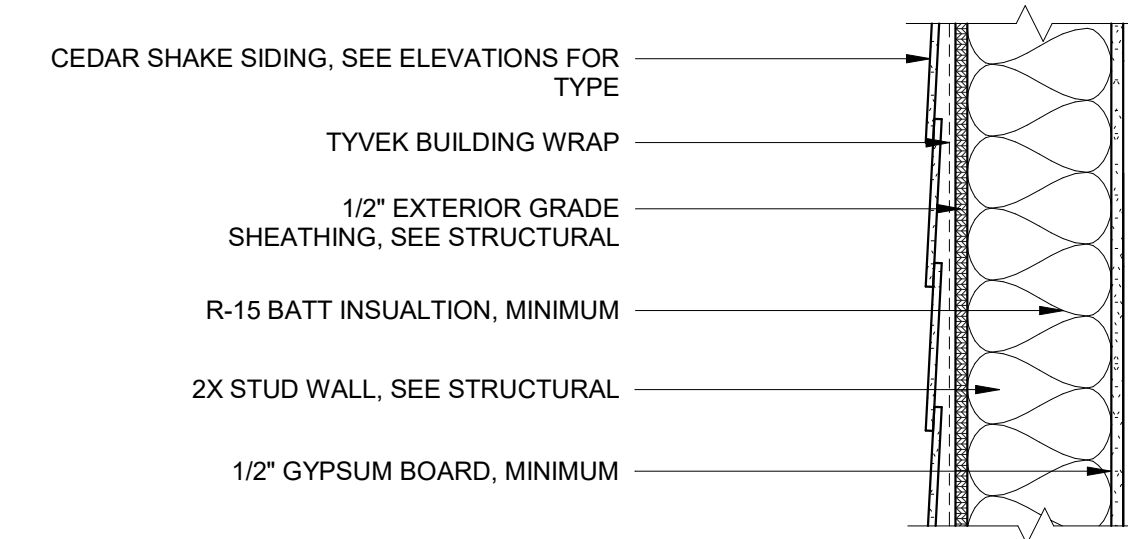

2 Typical Exterior Wall
1 1/2" = 1'-0"

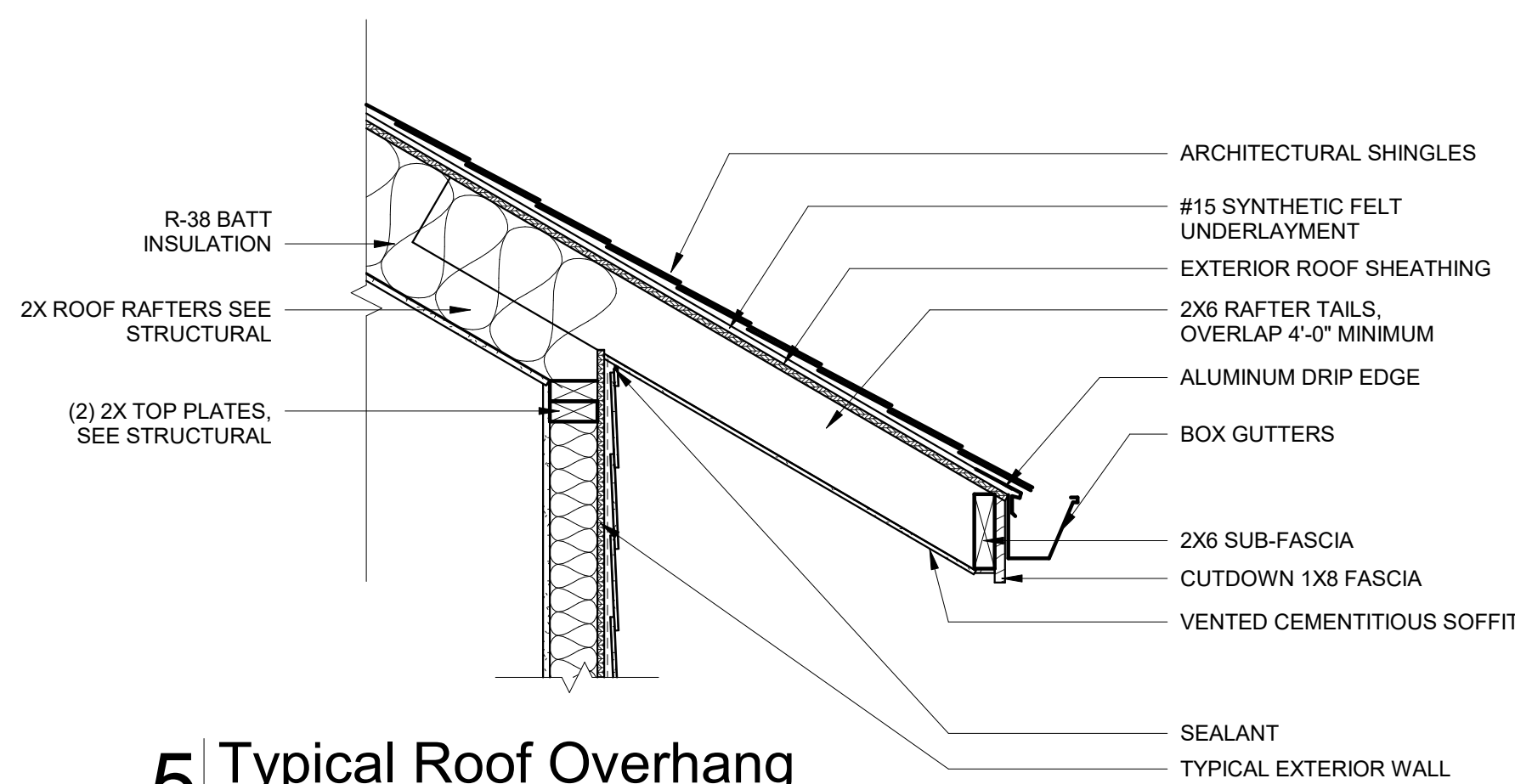

5 Typical Roof Overhang
1" = 1'-0"

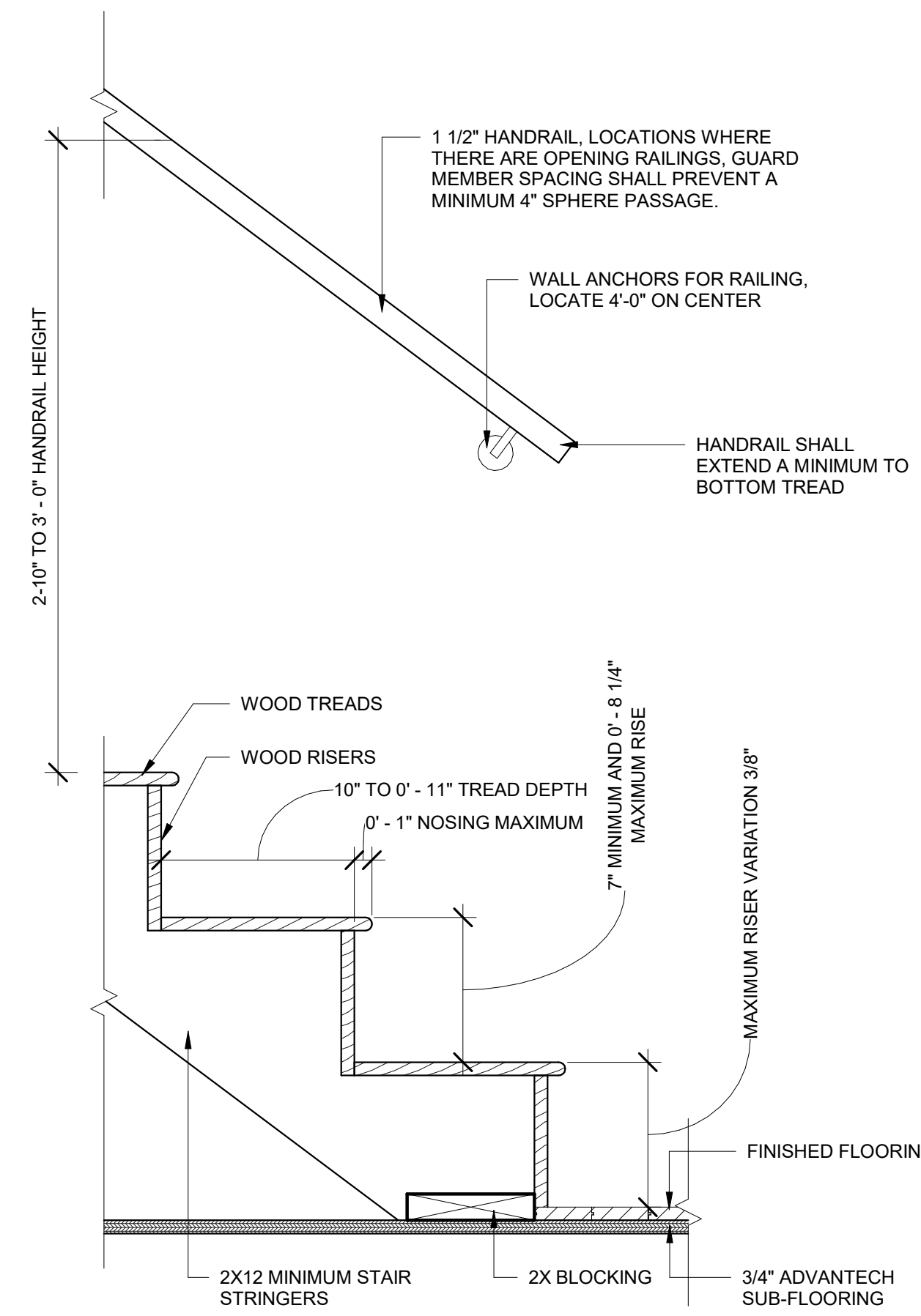

3 Typical Stair Detail
1 1/2" = 1'-0"

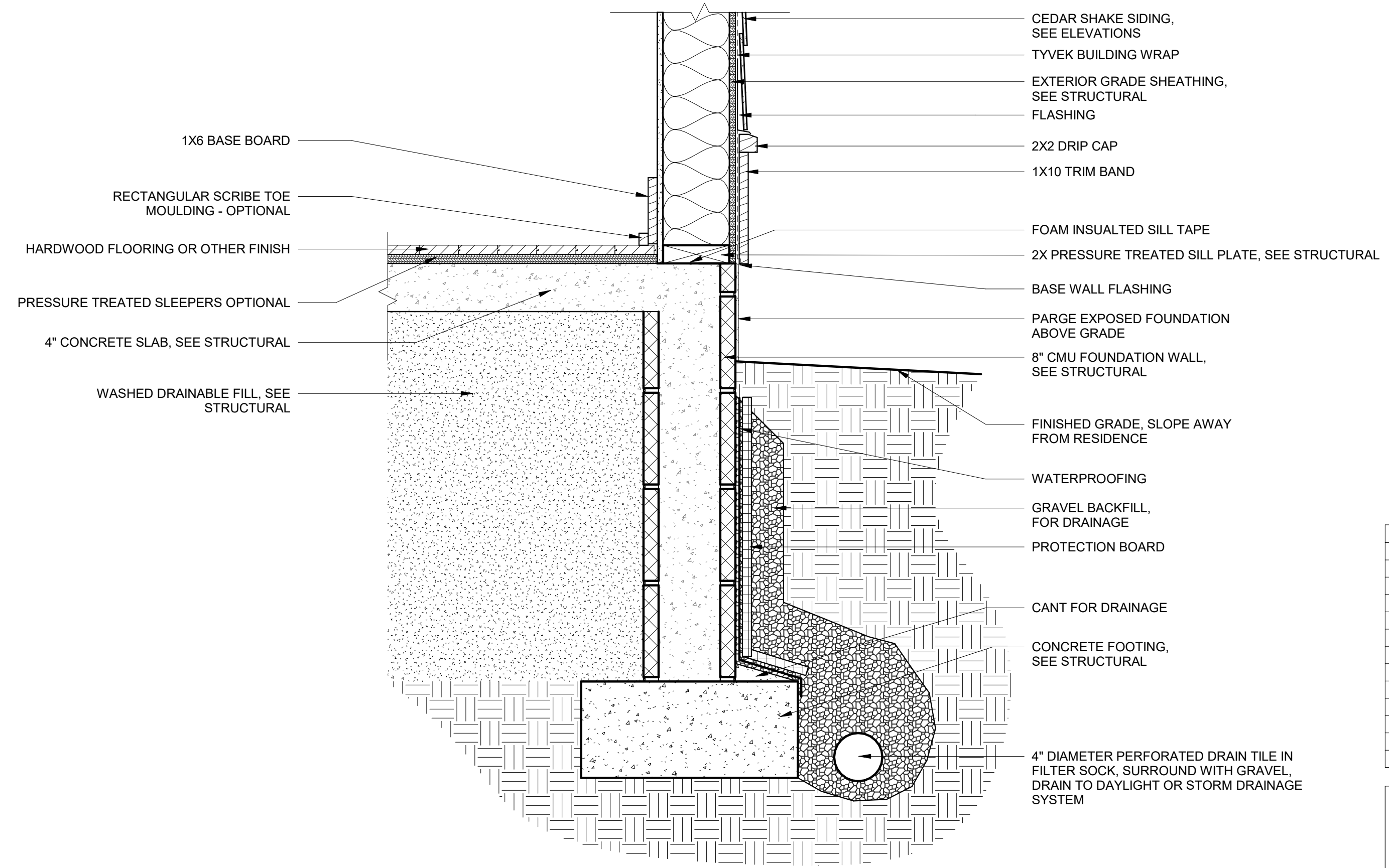

1 Typical Foundation Wall
1 1/2" = 1'-0"

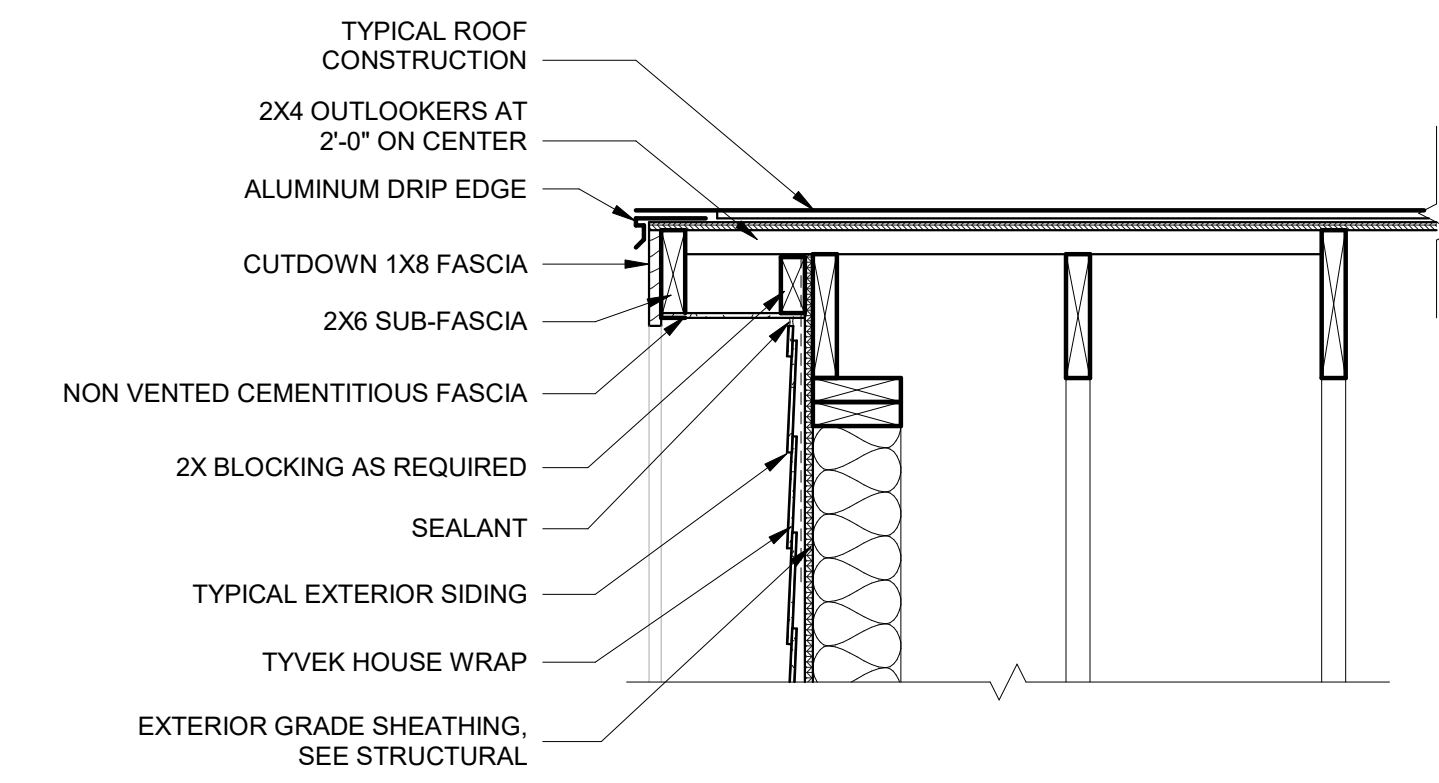

4 Typical Rake Detail
1" = 1'-0"

Proposed Residence

Atkins Road
Fuquay Varina, North Carolina

All drawing and designs are protected by commonlaw copyright and exclusively belong to Filter Design Studio, P.L.L.C. All use, printing, construction and modifications require express permission

No.	Description	Date

Details

Project number: 21-008
Date: 10/26/21

A501

Scale: As indicated

Architect Seal

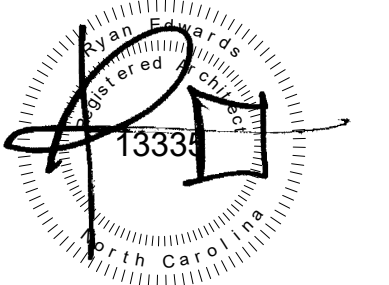

10/26/2021

Firm Seal

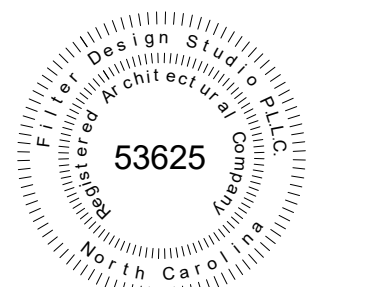

Architecture

Company: Filter Design Studio, P.L.L.C.
Architect: Ryan Edwards
Address: PO Box 735
Morehead City, NC 28557
Phone: 919-422-5598
Email: ryan@filterdesignstudio.com

Landscape Architecture

Company: Filter Design Studio, P.L.L.C.
Landscape Architect: Thomas "Jay" Horton
Address: PO Box 735
Morehead City, NC 28557
Phone: 252-230-0788
Email: jay@filterdesignstudio.com

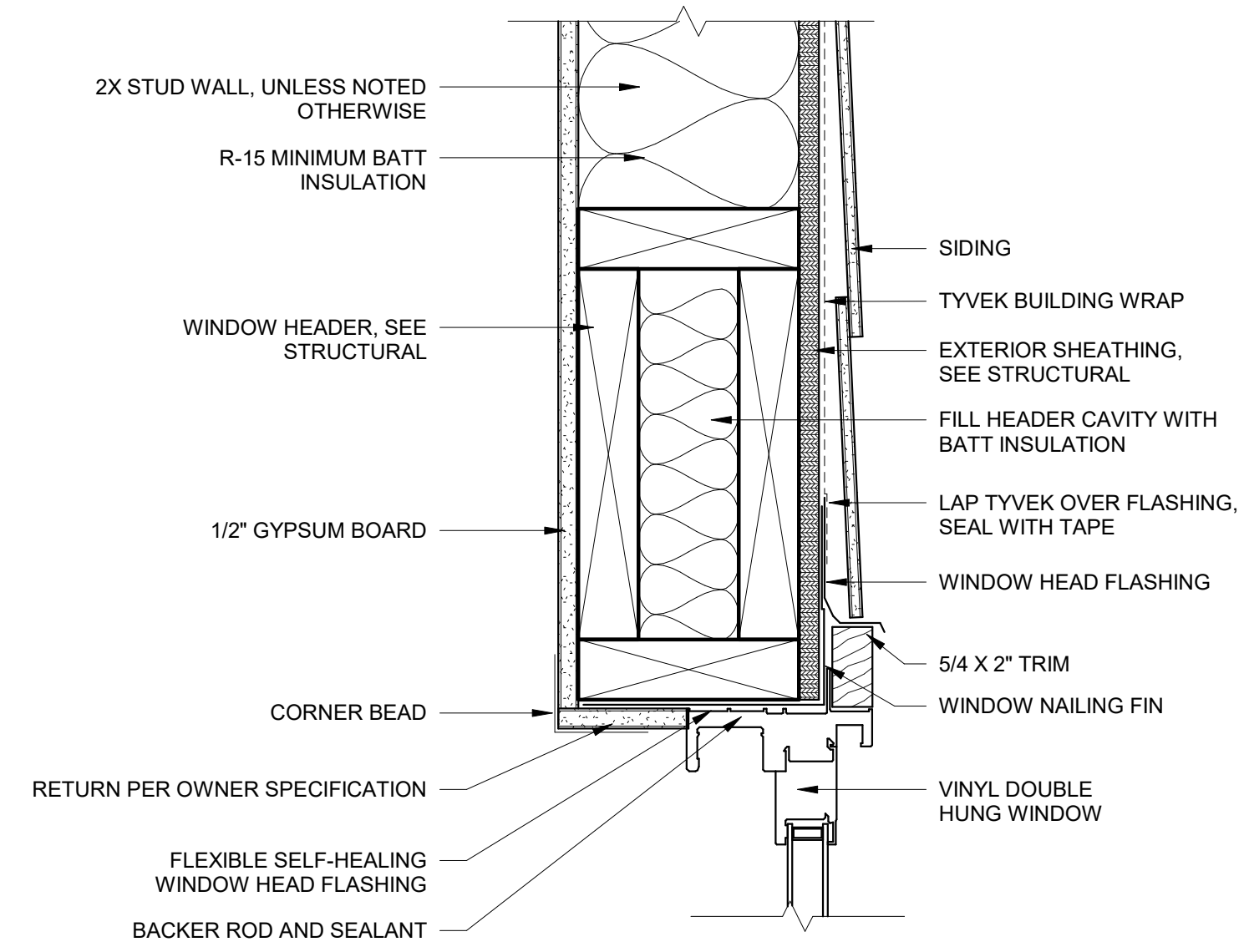

6 Typical Vinyl Window Head
3" = 1'-0"

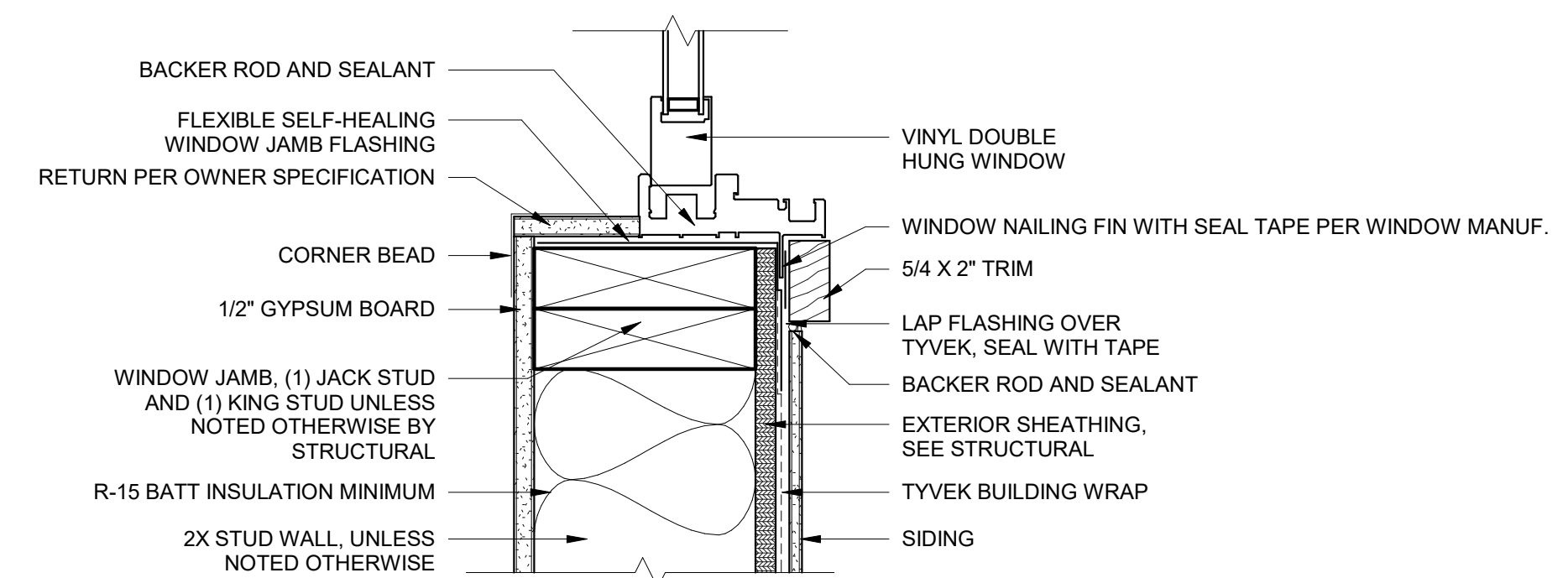

5 Typical Vinyl Window Jamb
3" = 1'-0"

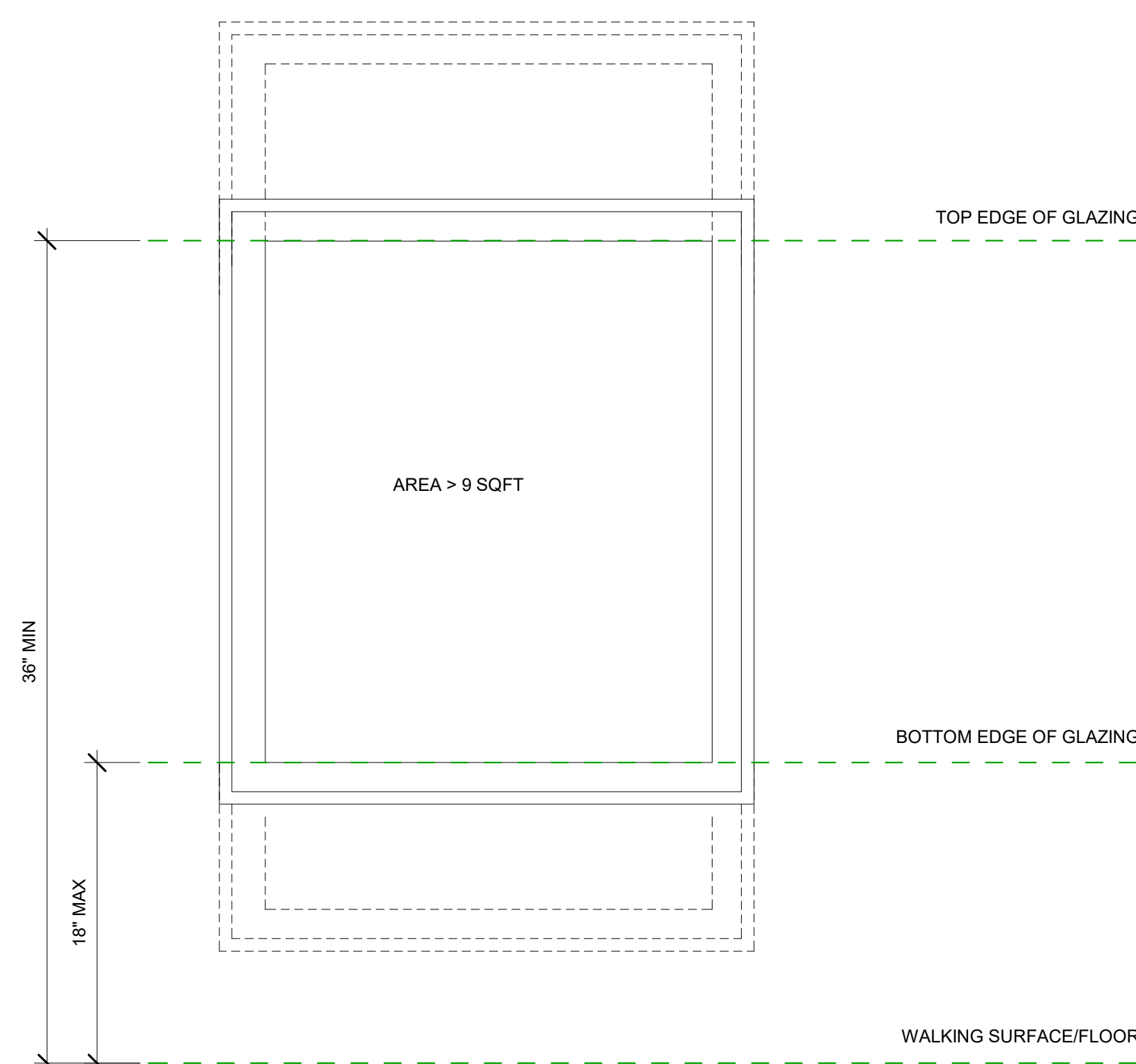

7 Tempered Glass Infographic
NOT TO SCALE

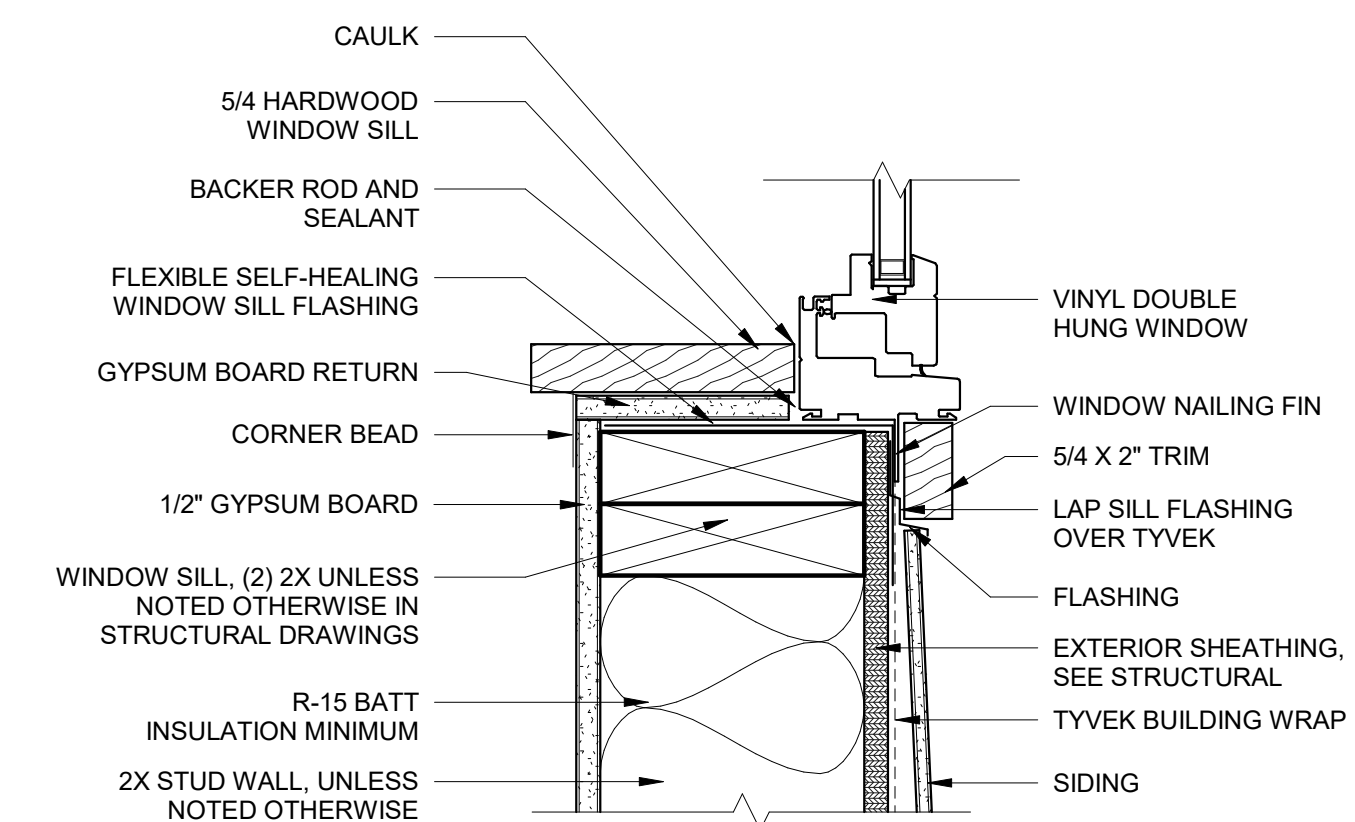

4 Typical Vinyl Window Sill
3" = 1'-0"

Proposed Residence

Atkins Road
Fuquay Varina, North Carolina

All drawing and designs are protected by commonlaw copyright and exclusively belong to Filter Design Studio, P.L.L.C. All use, printing, construction and modifications require express permission

No.	Description	Date

Window Details

Project number: 21-008
Date: 10/26/21

A502

Scale: As indicated

Architect Seal

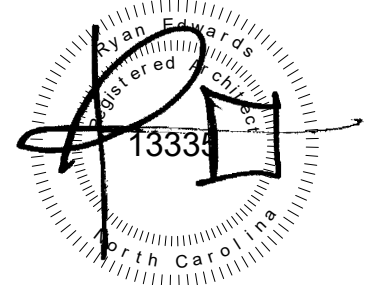

10/26/2021

Firm Seal



Architecture

Company: Filter Design Studio, P.L.L.C.
Architect: Ryan Edwards
Address: PO Box 735
Morehead City, NC 28557
Phone: 919-422-5598
Email: ryan@filterdesignstudio.com

Landscape Architecture

Company: Filter Design Studio, P.L.L.C.
Landscape Architect: Thomas "Jay" Horton
Address: PO Box 735
Morehead City, NC 28557
Phone: 252-230-0788
Email: jay@filterdesignstudio.com

Proposed Residence

Atkins Road

Fuquay Varina, North Carolina

All drawing and designs are protected by commonlaw copyright and exclusively belong to Filter Design Studio, P.L.L.C. All use, printing, construction and modifications require express permission

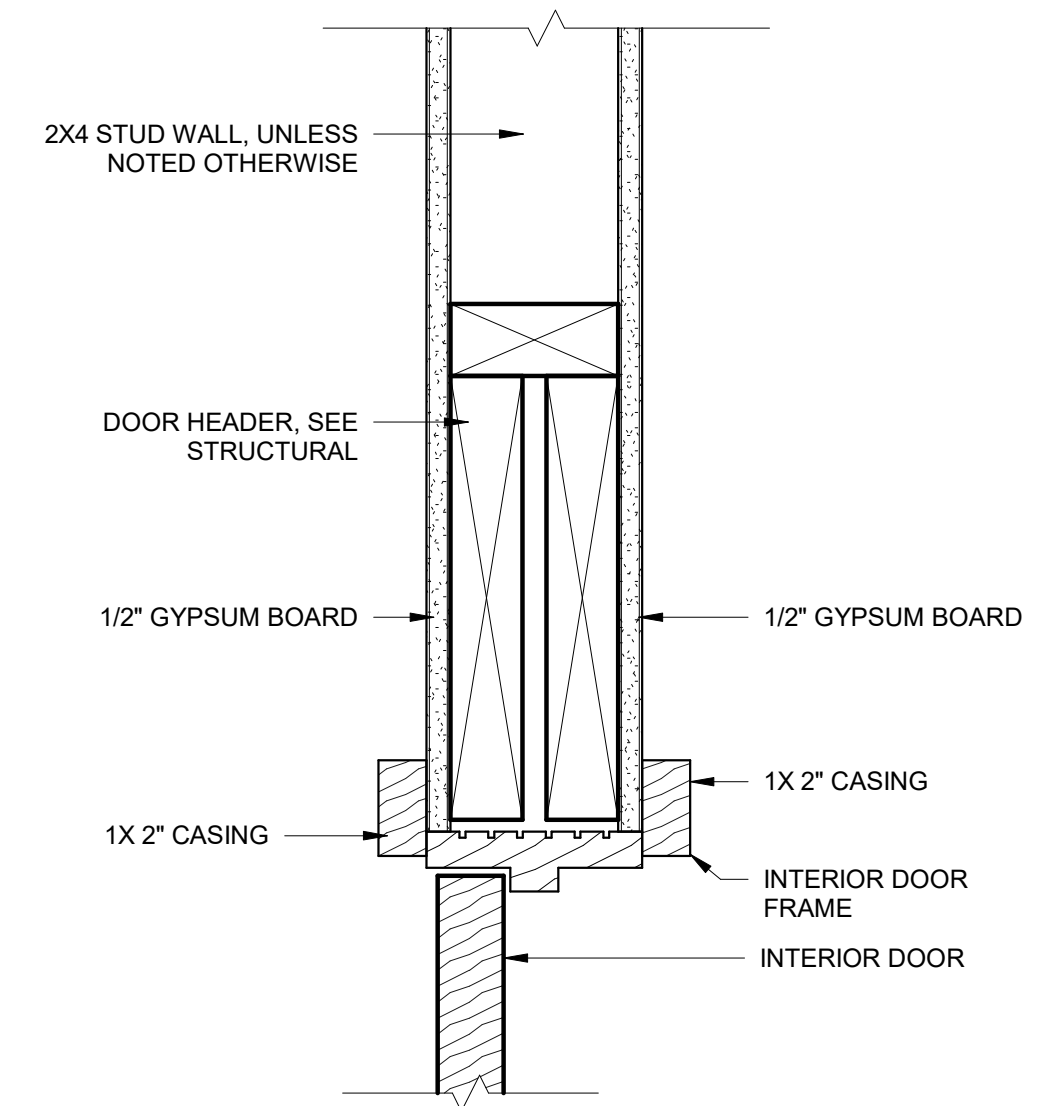

6 Typical Interior Door Head
3" = 1'-0"

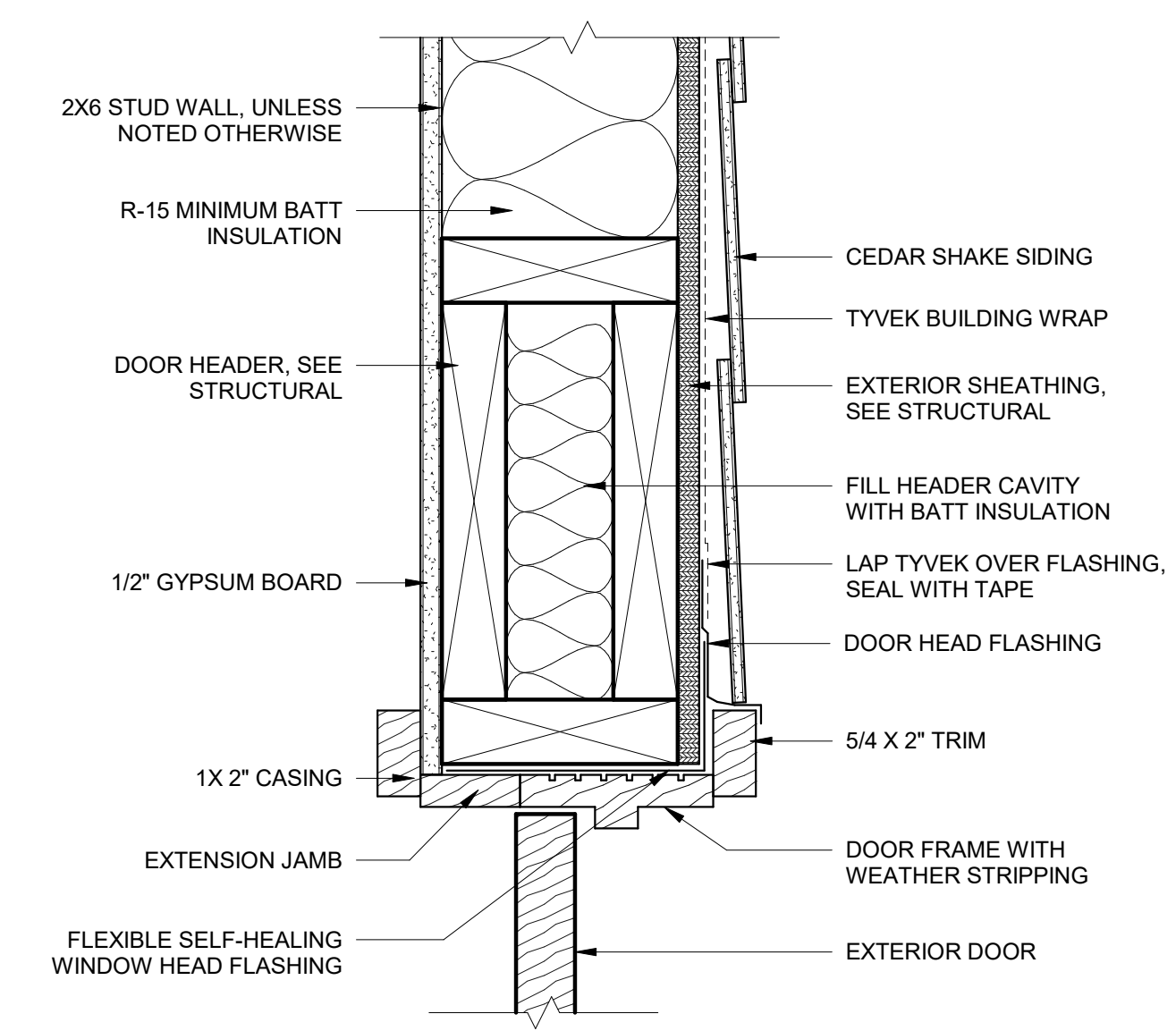

3 Typical Exterior Door Head
3" = 1'-0"

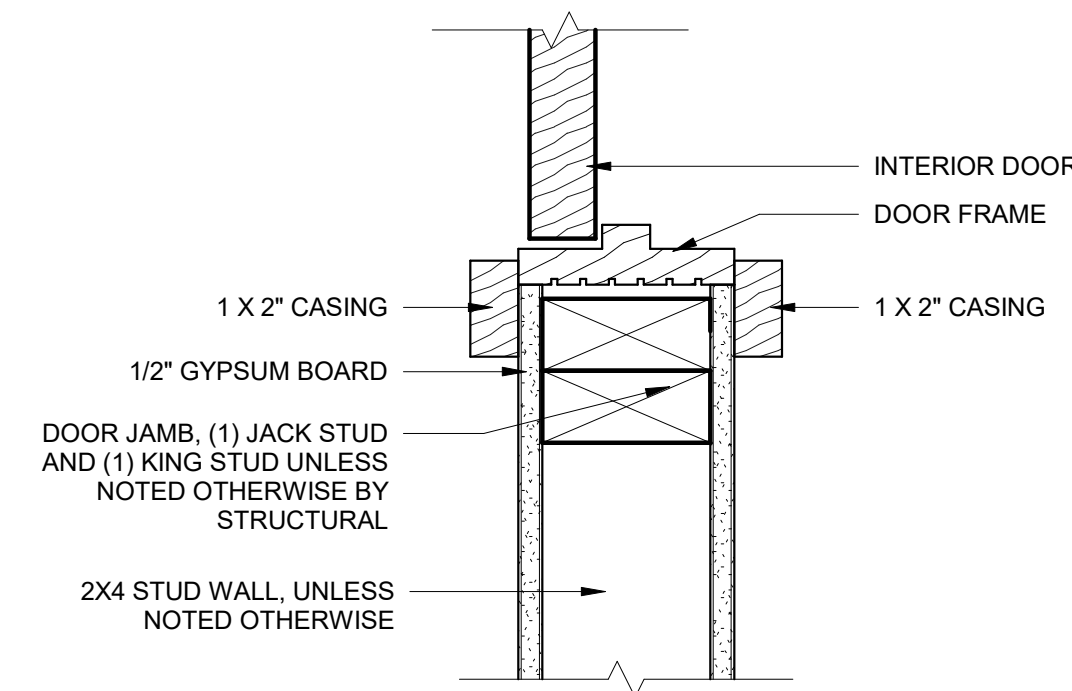

5 Typical Interior Door Jamb
3" = 1'-0"

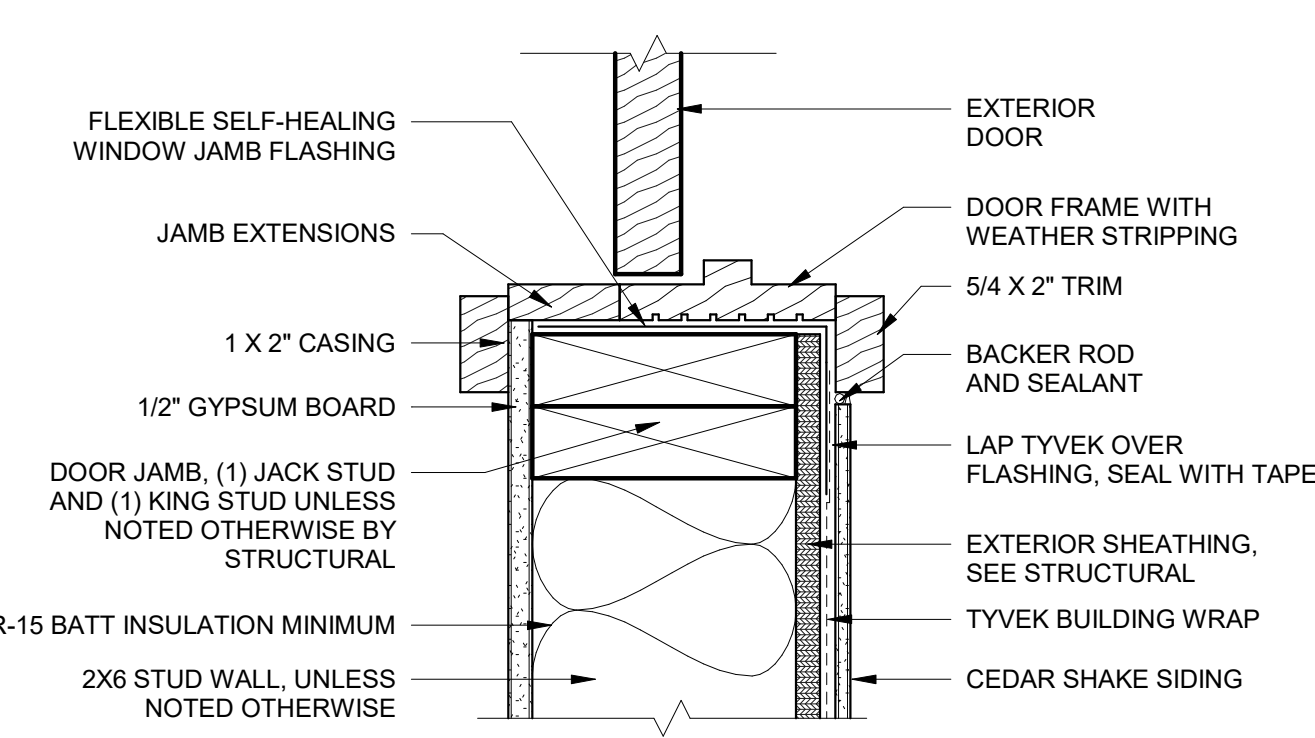

2 Typical Exterior Door Jamb
3" = 1'-0"

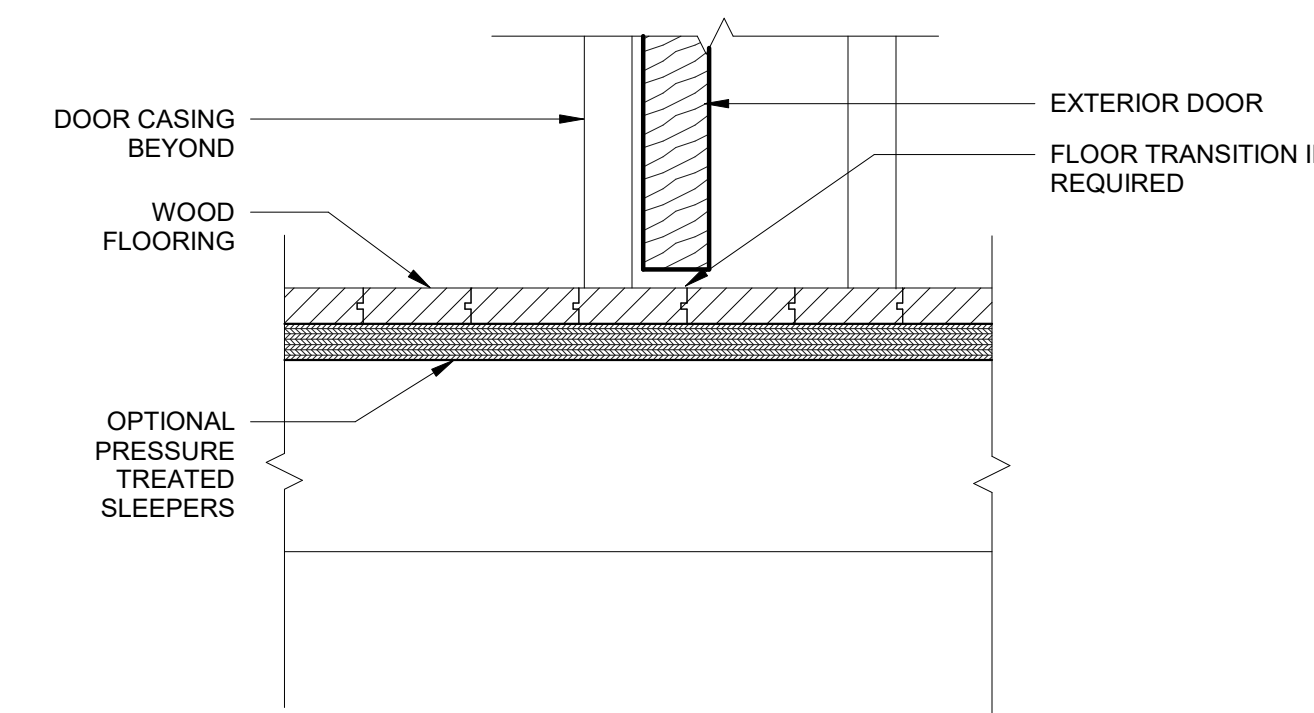

4 Typical Interior Door Sill
3" = 1'-0"

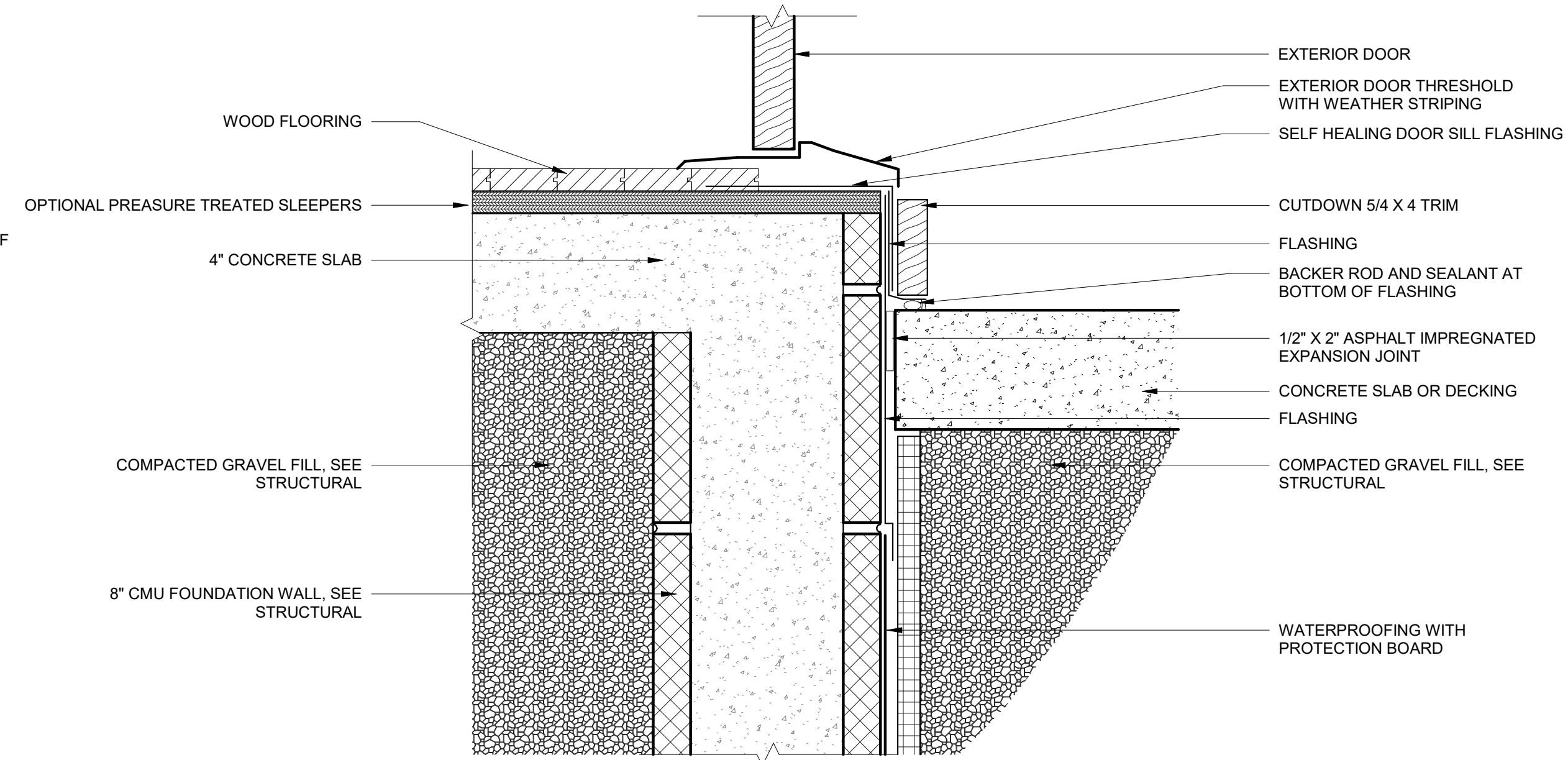

1 Typical Exterior Door Sill Concrete
3" = 1'-0"

No.	Description	Date

Door Details

Project number: 21-008
Date: 10/26/21

A503

Scale: 3" = 1'-0"