

Job Q-2101667-1	Truss CAP1	Truss Type Piggyback	Qty 2	Ply 1	Brooklyn RH V2-Roof Job Reference (optional)
--------------------	---------------	-------------------------	----------	----------	---

Peak Truss Builders LLC, New Hill, user

Run: 8.43 S Feb 3 2021 Print: 8.430 S Feb 3 2021 MiTek Industries, Inc. Wed Jul 28 08:34:36

Page: 1

ID:L0gL3afMopT0hF2T24H8xfz7PCA-NzrOpFshngtXHT7VjrWdjXpSv2o89nF10JEKJLybyY

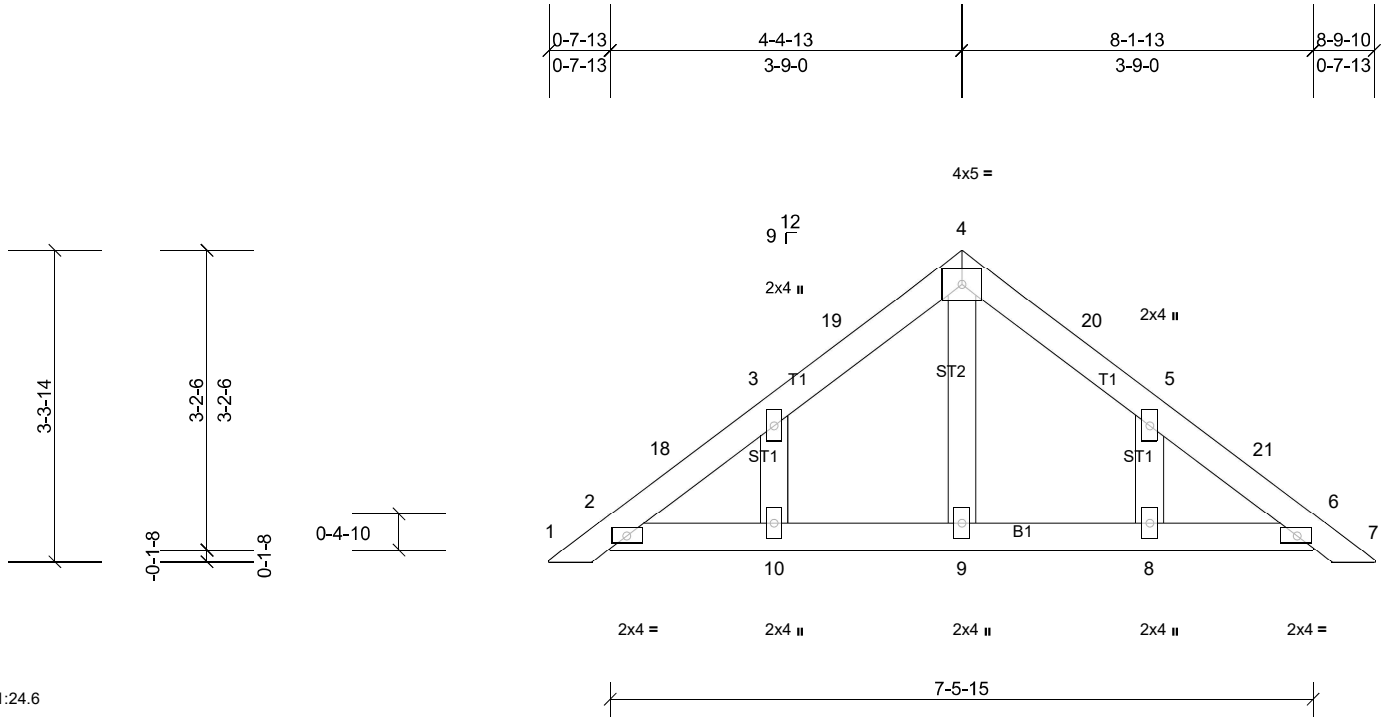

Scale = 1:24.6

Loading	(psf)	Spacing	2-0-0	CSI	DEFL	in	(loc)	l/defl	L/d	PLATES	GRIP	
TCLL (roof)	20.0	Plate Grip DOL	1.15	TC	0.04	Vert(LL)	n/a	-	n/a	999	MT20	244/190
TCDL	10.0	Lumber DOL	1.15	BC	0.02	Vert(CT)	n/a	-	n/a	999		
BCLL	0.0*	Rep Stress Incr	YES	WB	0.03	Horz(CT)	0.00	6	n/a	n/a		
BCDL	10.0	Code	IRC2015/TPI2014	Matrix-MP							Weight: 35 lb	FT = 20%

LUMBER

TOP CHORD 2x4 SP No.1
 BOT CHORD 2x4 SP No.1
 OTHERS 2x4 SP No.3

BRACING

TOP CHORD
 BOT CHORD

Structural wood sheathing directly applied or 6-0-0 oc purlins.
 Rigid ceiling directly applied or 10-0-0 oc bracing.

MiTek recommends that Stabilizers and required cross bracing be installed during truss erection, in accordance with Stabilizer Installation guide.

REACTIONS All bearings 7-5-15.

(lb) - Max Horiz 2=57 (LC 10), 11=57 (LC 10)
 Max Uplift All uplift 100 (lb) or less at joint(s) 2, 6, 8, 10, 11, 15
 Max Grav All reactions 250 (lb) or less at joint(s) 2, 6, 8, 9, 10, 11, 15

FORCES (lb) - Max. Comp./Max. Ten. - All forces 250 (lb) or less except when shown.

NOTES

- Unbalanced roof live loads have been considered for this design.
- Wind: ASCE 7-10; Vult=120mph (3-second gust) Vasd=95mph; TC DL=6.0psf; BCDL=6.0psf; h=30ft; B=20ft; L=20ft; eave=4ft; Cat. II; Exp B; Enclosed; MWFRS (directional) and C-C Exterior (2) 0-3-1 to 3-3-1, Interior (1) 3-3-1 to 4-5-2, Exterior (2) 4-5-2 to 7-5-2, Interior (1) 7-5-2 to 8-7-3 zone; cantilever left and right exposed; end vertical left and right exposed; C-C for members and forces & MWFRS for reactions shown; Lumber DOL=1.60 plate grip DOL=1.60
- Truss designed for wind loads in the plane of the truss only. For studs exposed to wind (normal to the face), see Standard Industry Gable End Details as applicable, or consult qualified building designer as per ANSI/TPI 1.
- Gable requires continuous bottom chord bearing.
- Gable studs spaced at 2-0-0 oc.
- * This truss has been designed for a live load of 20.0psf on the bottom chord in all areas where a rectangle 3-06-00 tall by 2-00-00 wide will fit between the bottom chord and any other members.
- Provide mechanical connection (by others) of truss to bearing plate capable of withstanding 100 lb uplift at joint(s) 2, 6, 10, 8, 2, 6.
- This truss is designed in accordance with the 2015 International Residential Code sections R502.11.1 and R802.10.2 and referenced standard ANSI/TPI 1.
- See Standard Industry Piggyback Truss Connection Detail for Connection to base truss as applicable, or consult qualified building designer.

LOAD CASE(S) Standard

Job Q-2101667-1	Truss CAP2	Truss Type Piggyback	Qty 26	Ply 1	Brooklyn RH V2-Roof Job Reference (optional)
--------------------	---------------	-------------------------	-----------	----------	---

Peak Truss Builders LLC, New Hill, user

Run: 8.43 S Feb 3 2021 Print: 8.430 S Feb 3 2021 MiTek Industries, Inc. Wed Jul 28 08:34:37

Page: 1

ID:o770?grKaE1X9yRbcVaRjXz7PDD-Jyz9ExuxJH7FXnHuqGY5oyumwsRidhs?TcjQODytbyW

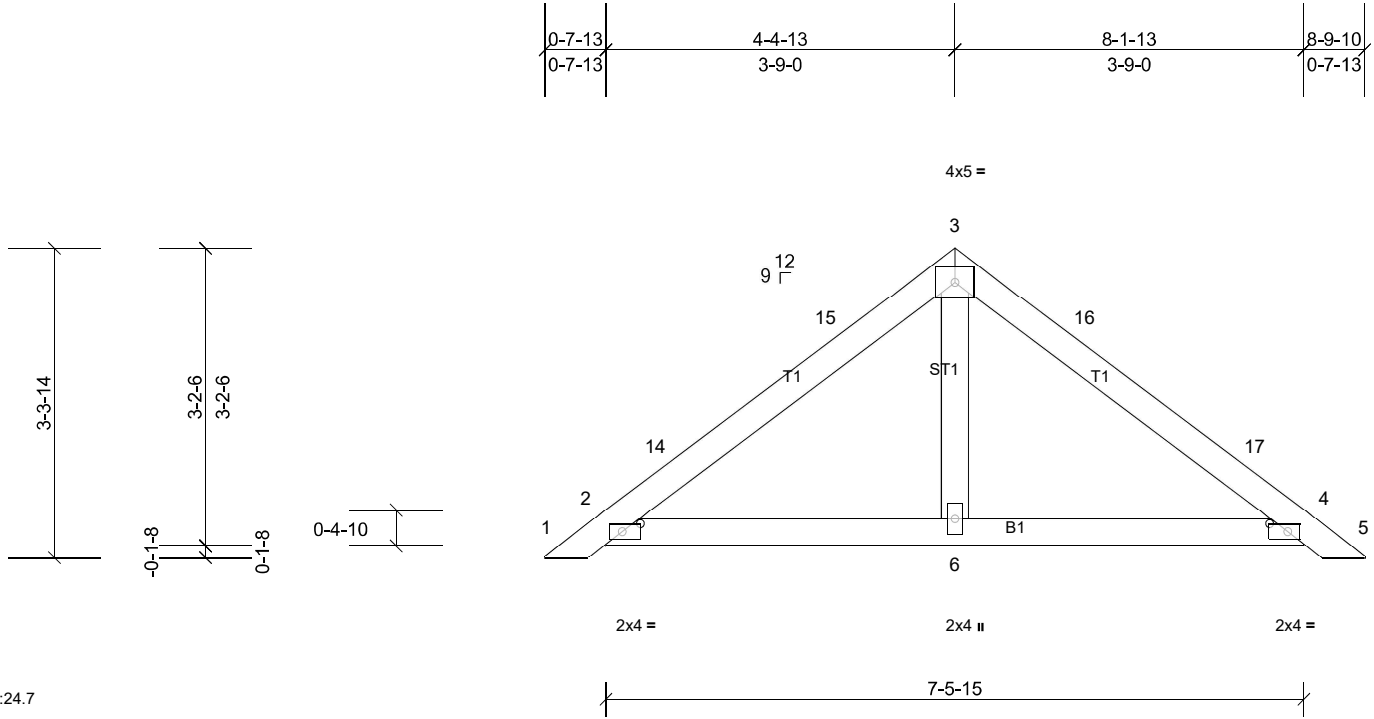

Scale = 1:24.7

Plate Offsets (X, Y): [2:0-2-5,0-1-0], [4:0-2-5,0-1-0]

Loading	(psf)	Spacing	2-0-0	CSI	DEFL	in	(loc)	l/defl	L/d	PLATES	GRIP	
TCLL (roof)	20.0	Plate Grip DOL	1.15	TC	0.13	Vert(LL)	n/a	-	n/a	999	MT20	244/190
TCDL	10.0	Lumber DOL	1.15	BC	0.14	Vert(CT)	n/a	-	n/a	999		
BCLL	0.0*	Rep Stress Incr	YES	WB	0.02	Horz(CT)	0.00	2	n/a	n/a		
BCDL	10.0	Code	IRC2015/TPI2014	Matrix-MP							Weight: 31 lb	FT = 20%

LUMBER

TOP CHORD 2x4 SP No.1
 BOT CHORD 2x4 SP No.1
 OTHERS 2x4 SP No.3

BRACING

TOP CHORD
 BOT CHORD

Structural wood sheathing directly applied or 6-0-0 oc purlins.
 Rigid ceiling directly applied or 10-0-0 oc bracing.

MiTek recommends that Stabilizers and required cross bracing be installed during truss erection, in accordance with Stabilizer Installation guide.

REACTIONS All bearings 7-5-15.

- (lb) - Max Horiz 2=-57 (LC 9), 7=-57 (LC 9)
- Max Uplift All uplift 100 (lb) or less at joint(s) 2, 4, 7, 11
- Max Grav All reactions 250 (lb) or less at joint(s) 2, 4, 6, 7, 11

FORCES (lb) - Max. Comp./Max. Ten. - All forces 250 (lb) or less except when shown.

NOTES

- 1) Unbalanced roof live loads have been considered for this design.
- 2) Wind: ASCE 7-10; Vult=120mph (3-second gust) Vasd=95mph; TCDL=6.0psf; BCDL=6.0psf; h=30ft; B=20ft; L=20ft; eave=4ft; Cat. II; Exp B; Enclosed; MWFRS (directional) and C-C Exterior (2) 0-3-1 to 3-3-1, Interior (1) 3-3-1 to 4-5-2, Exterior (2) 4-5-2 to 7-5-2, Interior (1) 7-5-2 to 8-7-3 zone; cantilever left and right exposed ; end vertical left and right exposed;C-C for members and forces & MWFRS for reactions shown; Lumber DOL=1.60 plate grip DOL=1.60
- 3) Truss designed for wind loads in the plane of the truss only. For studs exposed to wind (normal to the face), see Standard Industry Gable End Details as applicable, or consult qualified building designer as per ANSI/TPI 1.
- 4) Gable requires continuous bottom chord bearing.
- 5) Gable studs spaced at 4-0-0 oc.
- 6) * This truss has been designed for a live load of 20.0psf on the bottom chord in all areas where a rectangle 3-06-00 tall by 2-00-00 wide will fit between the bottom chord and any other members.
- 7) Provide mechanical connection (by others) of truss to bearing plate capable of withstanding 100 lb uplift at joint(s) 2, 4, 2, 4.
- 8) This truss is designed in accordance with the 2015 International Residential Code sections R502.11.1 and R802.10.2 and referenced standard ANSI/TPI 1.
- 9) See Standard Industry Piggyback Truss Connection Detail for Connection to base truss as applicable, or consult qualified building designer.

LOAD CASE(S) Standard

Job Q-2101667-1	Truss CAP3	Truss Type Piggyback	Qty 1	Ply 1	Brooklyn RH V2-Roof Job Reference (optional)
--------------------	---------------	-------------------------	----------	----------	---

Peak Truss Builders LLC, New Hill, user

Run: 8.43 S Feb 3 2021 Print: 8.430 S Feb 3 2021 MiTek Industries, Inc. Wed Jul 28 08:34:38

Page: 1

ID:uexKFafPAytYMZ4mf8REtzytCl-n8WXRHuZ4bF58xs4Oz3KLARwgGnxM869iGT_wgytbyV

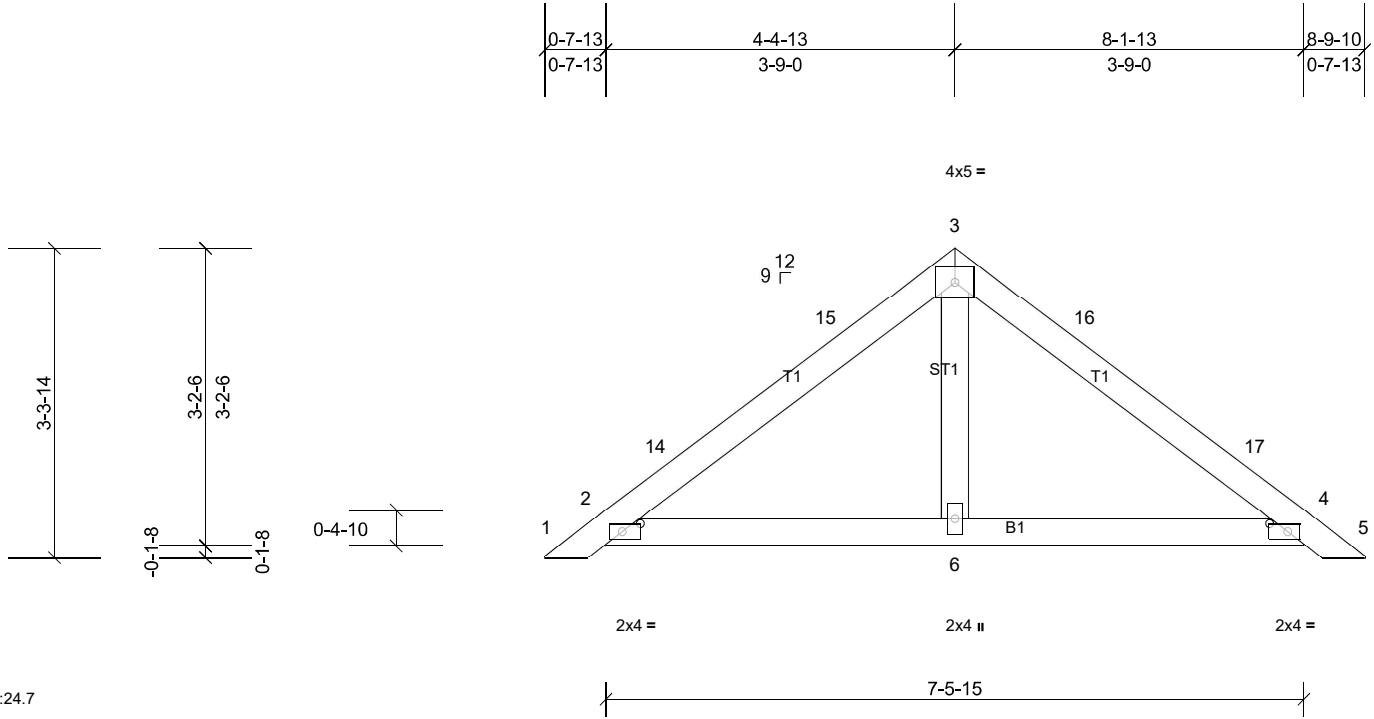

Scale = 1:24.7

Plate Offsets (X, Y): [2:0-2-5,0-1-0], [4:0-2-5,0-1-0]

Loading	(psf)	Spacing	2-0-0	CSI	DEFL	in	(loc)	l/defl	L/d	PLATES	GRIP	
TCLL (roof)	20.0	Plate Grip DOL	1.15	TC	0.13	Vert(LL)	n/a	-	n/a	999	MT20	244/190
TCDL	10.0	Lumber DOL	1.15	BC	0.14	Vert(CT)	n/a	-	n/a	999		
BCLL	0.0*	Rep Stress Incr	YES	WB	0.02	Horz(CT)	0.00	2	n/a	n/a		
BCDL	10.0	Code	IRC2015/TPI2014	Matrix-MP							Weight: 31 lb	FT = 20%

LUMBER

TOP CHORD 2x4 SP No.1
 BOT CHORD 2x4 SP No.1
 OTHERS 2x4 SP No.3

BRACING

TOP CHORD
 BOT CHORD

Structural wood sheathing directly applied or 6-0-0 oc purlins.
 Rigid ceiling directly applied or 10-0-0 oc bracing.

MiTek recommends that Stabilizers and required cross bracing be installed during truss erection, in accordance with Stabilizer Installation guide.

REACTIONS All bearings 7-5-15.

(lb) - Max Horiz 2=-57 (LC 9), 7=-57 (LC 9)
 Max Uplift All uplift 100 (lb) or less at joint(s) 2, 4, 7, 11
 Max Grav All reactions 250 (lb) or less at joint(s) 2, 4, 6, 7, 11

FORCES (lb) - Max. Comp./Max. Ten. - All forces 250 (lb) or less except when shown.

NOTES

- Unbalanced roof live loads have been considered for this design.
- Wind: ASCE 7-10; Vult=120mph (3-second gust) Vasd=95mph; TCDL=6.0psf; BCDL=6.0psf; h=30ft; B=20ft; L=20ft; eave=4ft; Cat. II; Exp B; Enclosed; MWFRS (directional) and C-C Exterior (2) 0-3-1 to 3-3-1, Interior (1) 3-3-1 to 4-5-2, Exterior (2) 4-5-2 to 7-5-2, Interior (1) 7-5-2 to 8-7-3 zone; cantilever left and right exposed; end vertical left and right exposed; C-C for members and forces & MWFRS for reactions shown; Lumber DOL=1.60 plate grip DOL=1.60
- Truss designed for wind loads in the plane of the truss only. For studs exposed to wind (normal to the face), see Standard Industry Gable End Details as applicable, or consult qualified building designer as per ANSI/TPI 1.
- Gable requires continuous bottom chord bearing.
- Gable studs spaced at 4-0-0 oc.
- * This truss has been designed for a live load of 20.0psf on the bottom chord in all areas where a rectangle 3-06-00 tall by 2-00-00 wide will fit between the bottom chord and any other members.
- Provide mechanical connection (by others) of truss to bearing plate capable of withstanding 100 lb uplift at joint(s) 2, 4, 2, 4.
- This truss is designed in accordance with the 2015 International Residential Code sections R502.11.1 and R802.10.2 and referenced standard ANSI/TPI 1.
- See Standard Industry Piggyback Truss Connection Detail for Connection to base truss as applicable, or consult qualified building designer.

LOAD CASE(S) Standard

Job Q-2101667-1	Truss T1	Truss Type Attic	Qty 6	Ply 1	Brooklyn RH V2-Roof Job Reference (optional)
--------------------	-------------	---------------------	----------	----------	---

Peak Truss Builders LLC, New Hill, user

Run: 8.43 S Feb 3 2021 Print: 8.430 S Feb 3 2021 MiTek Industries, Inc. Wed Jul 28 08:34:38

Page: 1

ID:nQslJYoic?celqRwfoXZqhz7PFt-n8WXRHuZ4bF58xs4Oz3KLARjQGbMM2L9IGT_wgytbyV

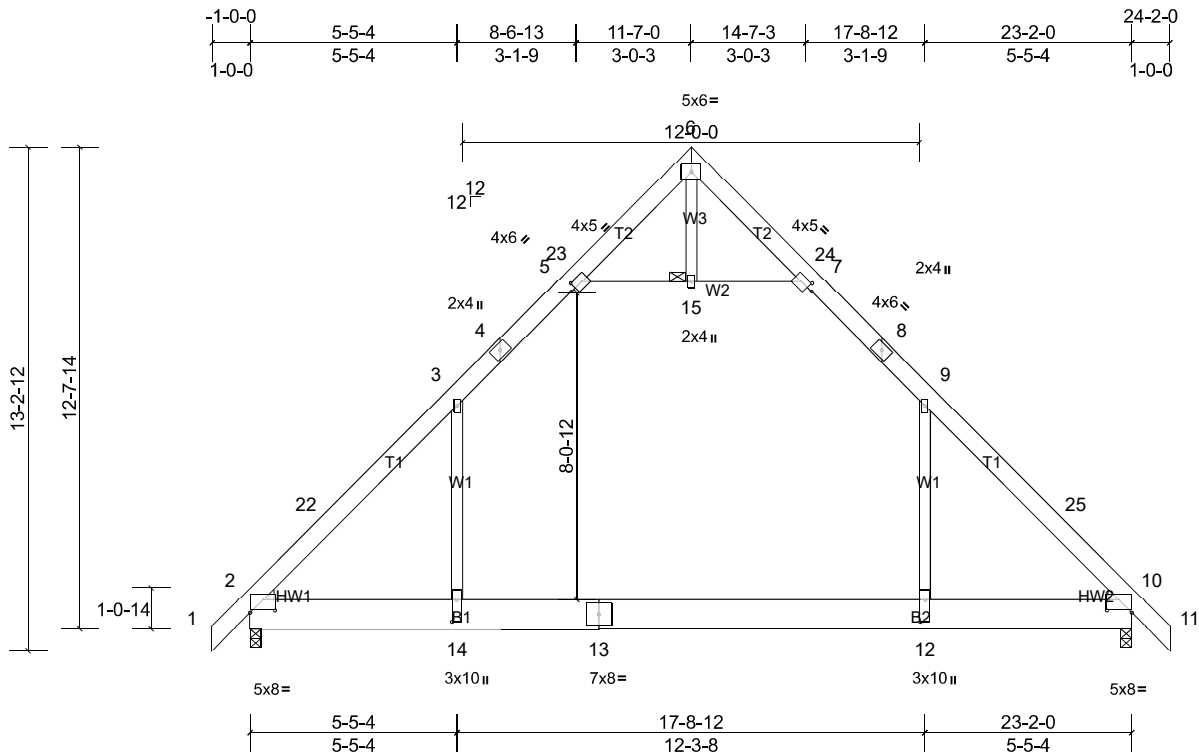

Scale = 1:60.5

Plate Offsets (X, Y): [2:0-8-0,0-0-13], [5:0-1-13,0-2-0], [7:0-1-13,0-2-0], [10:0-8-0,0-0-13], [12:0-7-0,0-1-8], [14:0-7-0,0-1-8]

Loading	(psf)	Spacing	2-0-0	CSI		DEFL	in	(loc)	l/defl	L/d	PLATES	GRIP
TCLL (roof)	20.0	Plate Grip DOL	1.15	TC	0.98	Vert(LL)	-0.37	12-14	>748	240	MT20	244/190
TCDL	10.0	Lumber DOL	1.15	BC	0.94	Vert(CT)	-0.53	12-14	>526	180		
BCLL	0.0*	Rep Stress Incr	YES	WB	0.39	Horz(CT)	0.02	2	n/a	n/a		
BCDL	10.0	Code	IRC2015/TPI2014	Matrix-MS		Attic	-0.19	12-14	>785	360		
											Weight: 209 lb	FT = 20%

LUMBER

TOP CHORD 2x6 SP No.2 *Except* T1:2x6 SP No.1
 BOT CHORD 2x10 SP No.2
 WEBS 2x4 SP No.3
 WEDGE Left: 2x4 SP No.3
 Right: 2x4 SP No.3

BRACING

TOP CHORD Structural wood sheathing directly applied.
 BOT CHORD Rigid ceiling directly applied or 2-2-0 oc bracing.
 JOINTS 1 Brace at Jt(s): 15

REACTIONS (lb/size) 2=1048/0-3-8, (min. 0-2-1), 10=1048/0-3-8, (min. 0-2-1)
 Max Horiz 2=254 (LC 10)
 Max Uplift 2=-112 (LC 11), 10=-112 (LC 11)
 Max Grav 2=1306 (LC 17), 10=1306 (LC 18)

FORCES (lb) - Max. Comp./Max. Ten. - All forces 250 (lb) or less except when shown.
 TOP CHORD 2-22=-1638/41, 3-22=-1477/66, 3-4=-930/144, 4-5=-822/177, 7-8=-821/177, 8-9=-930/144, 9-25=-1476/66,
 10-25=-1637/41
 BOT CHORD 2-14=-72/985, 13-14=0/987, 12-13=0/987, 10-12=0/985
 WEBS 9-12=0/815, 3-14=0/815, 5-15=-1088/274, 7-15=-1088/274

NOTES

- Unbalanced roof live loads have been considered for this design.
- Wind: ASCE 7-10; Vult=120mph (3-second gust) Vasd=95mph; TCDL=6.0psf; BCDL=6.0psf; h=30ft; B=20ft; L=23ft; eave=4ft; Cat. II; Exp B; Enclosed; MWFRS (directional) and C-C Exterior (2) -1-0-0 to 2-0-0, Interior (1) 2-0-0 to 11-7-0, Exterior (2) 11-7-0 to 14-7-0, Interior (1) 14-7-0 to 24-2-0 zone; cantilever left and right exposed ; end vertical left and right exposed;C-C for members and forces & MWFRS for reactions shown; Lumber DOL=1.60 plate grip DOL=1.60
- * This truss has been designed for a live load of 20.0psf on the bottom chord in all areas where a rectangle 3-06-00 tall by 2-00-00 wide will fit between the bottom chord and any other members.
- Ceiling dead load (5.0 psf) on member(s). 3-5, 7-9, 5-15, 7-15
- Bottom chord live load (40.0 psf) and additional bottom chord dead load (0.0 psf) applied only to room. 12-14
- Provide mechanical connection (by others) of truss to bearing plate capable of withstanding 112 lb uplift at joint 2 and 112 lb uplift at joint 10.
- This truss is designed in accordance with the 2015 International Residential Code sections R502.11.1 and R802.10.2 and referenced standard ANSI/TPI 1.
- Attic room checked for L/360 deflection.

LOAD CASE(S) Standard

MiTek recommends that Stabilizers and required cross bracing be installed during truss erection, in accordance with Stabilizer Installation guide.

Job Q-2101667-1	Truss T1A	Truss Type Attic	Qty 1	Ply 1	Brooklyn RH V2-Roof Job Reference (optional)
--------------------	--------------	---------------------	----------	----------	---

Peak Truss Builders LLC, New Hill, user

Run: 8.43 S Feb 3 2021 Print: 8.430 S Feb 3 2021 MiTek Industries, Inc. Wed Jul 28 08:34:39

Page: 1

ID:nQsJYoic?celqRwfoXZqhz7PFT-GK4vecvBruNym5RGyhbZuNz5lf535ZglwwCXT6tybyU

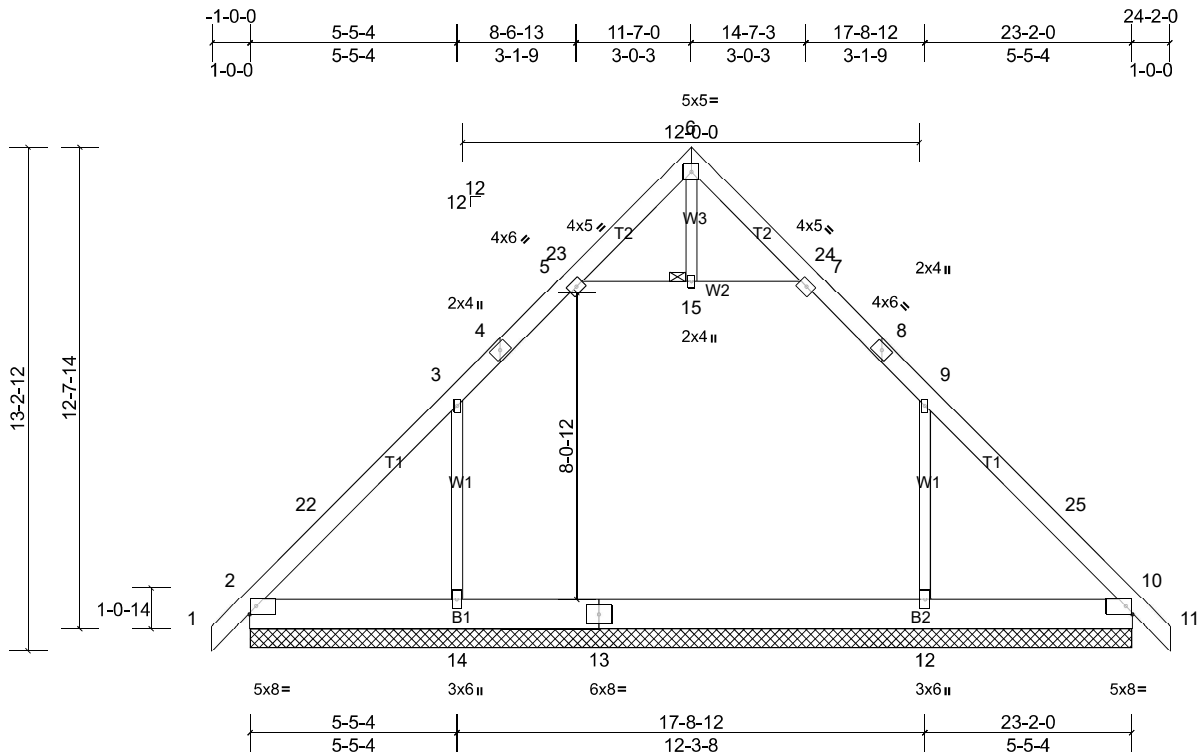

Scale = 1:60.5

Loading	(psf)	Spacing	2-0-0	CSI	DEFL	in	(loc)	l/defl	L/d	PLATES	GRIP	
TCLL (roof)	20.0	Plate Grip DOL	1.15	TC	0.14	Vert(LL)	n/a	-	n/a	999	MT20	244/190
TCDL	10.0	Lumber DOL	1.15	BC	0.27	Vert(CT)	n/a	-	n/a	999		
BCLL	0.0*	Rep Stress Incr	YES	WB	0.19	Horz(CT)	0.00	10	n/a	n/a		
BCDL	10.0	Code	IRC2015/TPI2014	Matrix-MS								Weight: 208 lb FT = 20%

LUMBER

TOP CHORD 2x6 SP No.2
 BOT CHORD 2x10 SP No.2
 WEBS 2x4 SP No.3

BRACING

TOP CHORD Structural wood sheathing directly applied or 6-0-0 oc purlins.
 BOT CHORD Rigid ceiling directly applied or 10-0-0 oc bracing.
 JOINTS 1 Brace at Jt(s): 15

REACTIONS All bearings 23-2-0.

(lb) - Max Horiz 2=254 (LC 10)
 Max Uplift All uplift 100 (lb) or less at joint(s) except 12=-131 (LC 11),
 14=-131 (LC 11)
 Max Grav All reactions 250 (lb) or less at joint(s) except 2=544 (LC 1),
 10=544 (LC 1), 12=820 (LC 18), 14=823 (LC 17)

FORCES

(lb) - Max. Comp./Max. Ten. - All forces 250 (lb) or less except when shown.
 TOP CHORD 2-22=-564/100, 3-22=-459/3, 3-4=-518/82, 4-5=-461/115, 7-8=-461/115, 8-9=-518/82, 9-25=-456/1, 10-25=-560/0
 BOT CHORD 2-14=-152/354, 13-14=0/354, 12-13=0/354, 10-12=0/354
 WEBS 9-12=-339/223, 3-14=-342/223

NOTES

- Unbalanced roof live loads have been considered for this design.
- Wind: ASCE 7-10; Vult=120mph (3-second gust) Vasd=95mph; TC DL=6.0psf; BC DL=6.0psf; h=30ft; B=20ft; L=23ft; eave=4ft; Cat. II; Exp B; Enclosed; MWFRS (directional) and C-C Exterior (2) -1-0-0 to 2-0-0, Interior (1) 2-0-0 to 11-7-0, Exterior (2) 11-7-0 to 14-7-0, Interior (1) 14-7-0 to 24-2-0 zone; cantilever left and right exposed; end vertical left and right exposed; C-C for members and forces & MWFRS for reactions shown; Lumber DOL=1.60 plate grip DOL=1.60
- Gable requires continuous bottom chord bearing.
- * This truss has been designed for a live load of 20.0psf on the bottom chord in all areas where a rectangle 3-06-00 tall by 2-00-00 wide will fit between the bottom chord and any other members, with BC DL = 10.0psf.
- Ceiling dead load (5.0 psf) on member(s). 3-5, 7-9, 5-15, 7-15
- Provide mechanical connection (by others) of truss to bearing plate capable of withstanding 131 lb uplift at joint 12 and 131 lb uplift at joint 14.
- Beveled plate or shim required to provide full bearing surface with truss chord at joint(s) 2.
- This truss is designed in accordance with the 2015 International Residential Code sections R502.11.1 and R802.10.2 and referenced standard ANSI/TPI 1.
- Attic room checked for L/360 deflection.

LOAD CASE(S) Standard

MiTek recommends that Stabilizers and required cross bracing be installed during truss erection, in accordance with Stabilizer Installation guide.

Job Q-2101667-1	Truss T1GRD	Truss Type Attic Girder	Qty 1	Ply 1	Brooklyn RH V2-Roof Job Reference (optional)
--------------------	----------------	----------------------------	----------	----------	---

Peak Truss Builders LLC, New Hill, user

Run: 8.43 S Feb 3 2021 Print: 8.430 S Feb 3 2021 MiTek Industries, Inc. Wed Jul 28 08:34:39

Page: 1

ID: JEIM6Cn4rhUn8gsk550KHTz7PFu-GK4vecvBruNym5RGyhbZuNz4Df4f5a1lwwCXT6tybyU

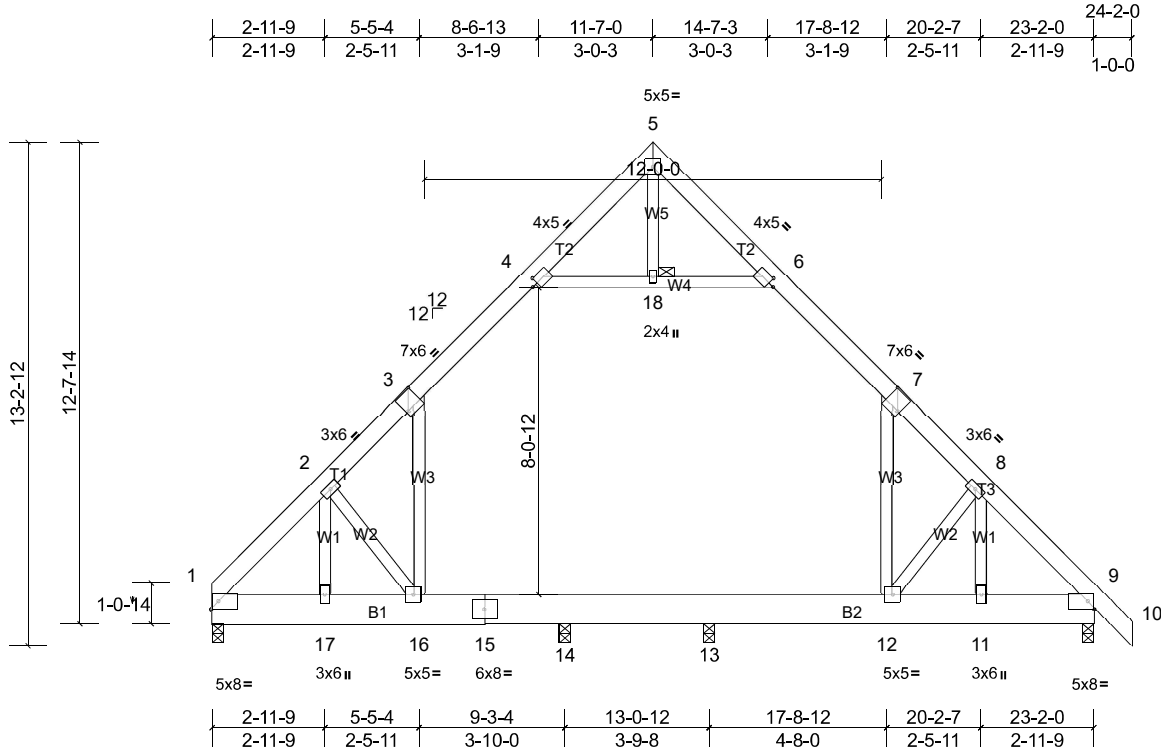

Scale = 1:60.5

Plate Offsets (X, Y): [3:0-5-4,Edge], [4:0-1-13,0-2-0], [6:0-1-13,0-2-0], [7:0-5-4,Edge]

Loading	(psf)	Spacing	2-0-0	CSI	DEFL	in	(loc)	l/defl	L/d	PLATES	GRIP
TCLL (roof)	20.0	Plate Grip DOL	1.15	TC	0.21	Vert(LL)	-0.03	12	>999	240	MT20 244/190
TCDL	10.0	Lumber DOL	1.15	BC	0.36	Vert(CT)	-0.05	12	>999	180	
BCLL	0.0*	Rep Stress Incr	NO	WB	0.10	Horz(CT)	0.00	9	n/a	n/a	
BCDL	10.0	Code	IRC2015/TPI2014	Matrix-MS		Attic	-0.03	12-13	>999	360	Weight: 223 lb FT = 20%

LUMBER

TOP CHORD 2x6 SP No.2
 BOT CHORD 2x10 SP No.2
 WEBS 2x4 SP No.3

BRACING

TOP CHORD Structural wood sheathing directly applied or 6-0-0 oc purlins.
 BOT CHORD Rigid ceiling directly applied or 10-0-0 oc bracing.
 JOINTS 1 Brace at Jt(s): 18

REACTIONS All bearings 0-3-8.

(lb) - Max Horiz 1=-247 (LC 5)
 Max Uplift All uplift 100 (lb) or less at joint(s) 1, 9, 13, 14
 Max Grav All reactions 250 (lb) or less at joint(s) except 1=725 (LC 1),
 9=802 (LC 1), 13=755 (LC 14), 14=654 (LC 13)

FORCES

(lb) - Max. Comp./Max. Ten. - All forces 250 (lb) or less except when shown.
 TOP CHORD 1-2=-811/77, 2-3=-688/68, 3-4=-582/155, 6-7=-580/155, 7-8=-680/68, 8-9=-817/76
 BOT CHORD 1-17=-141/648, 16-17=0/648, 15-16=0/456, 14-15=0/456, 13-14=0/456, 12-13=0/456, 11-12=0/564, 9-11=0/564
 WEBS 2-17=-73/255, 2-16=-310/176, 8-12=-343/173, 8-11=-70/286, 4-18=-310/217, 6-18=-310/217

NOTES

- Unbalanced roof live loads have been considered for this design.
- Wind: ASCE 7-10; Vult=120mph (3-second gust) Vasd=95mph; TCDL=6.0psf; BCDL=6.0psf; h=30ft; B=20ft; L=23ft; eave=4ft; Cat. II; Exp B; Enclosed; MWFRS (directional); cantilever left and right exposed; end vertical left and right exposed; Lumber DOL=1.60 plate grip DOL=1.60
- * This truss has been designed for a live load of 20.0psf on the bottom chord in all areas where a rectangle 3-06-00 tall by 2-00-00 wide will fit between the bottom chord and any other members.
- Ceiling dead load (5.0 psf) on member(s). 3-4, 6-7, 4-18, 6-18
- Bottom chord live load (40.0 psf) and additional bottom chord dead load (0.0 psf) applied only to room. 14-16, 13-14, 12-13
- Provide mechanical connection (by others) of truss to bearing plate capable of withstanding 100 lb uplift at joint(s) 1, 9, 14, 13.
- This truss is designed in accordance with the 2015 International Residential Code sections R502.11.1 and R802.10.2 and referenced standard ANSI/TPI 1.
- Attic room checked for L/360 deflection.

LOAD CASE(S) Standard

MiTek recommends that Stabilizers and required cross bracing be installed during truss erection, in accordance with Stabilizer Installation guide.

Job Q-2101667-1	Truss T2	Truss Type Monopitch	Qty 3	Ply 1	Brooklyn RH V2-Roof Job Reference (optional)
--------------------	-------------	-------------------------	----------	----------	---

Peak Truss Builders LLC, New Hill, user

Run: 8.43 S Feb 3 2021 Print: 8.430 S Feb 3 2021 MiTek Industries, Inc. Wed Jul 28 08:34:40

Page: 1

ID:r1k_usmR4OMwWWHXYNV5IGz7PFv-kXeHsywpcCVpOE0TV06oQbW403Mhq07S9ay5?YybtY

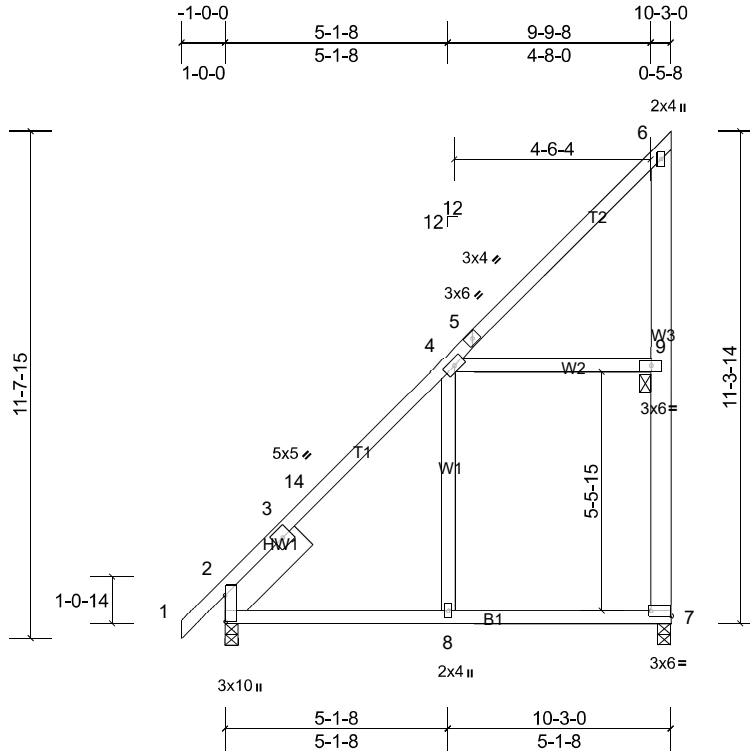

Scale = 1:53

Plate Offsets (X, Y): [2:0-7-7,0-0-3], [7:Edge,0-1-8]

Loading	(psf)	Spacing	2-0-0	CSI		DEFL	in	(loc)	l/defl	L/d	PLATES	GRIP
TCLL (roof)	20.0	Plate Grip DOL	1.15	TC	0.91	Vert(LL)	-0.24	8-12	>507	240	MT20	244/190
TCDL	10.0	Lumber DOL	1.15	BC	0.63	Vert(CT)	-0.38	8-12	>319	180		
BCLL	0.0*	Rep Stress Incr	YES	WB	0.18	Horz(CT)	0.10	2	n/a	n/a		
BCDL	10.0	Code	IRC2015/TPI2014	Matrix-MS							Weight: 87 lb	FT = 20%

LUMBER

TOP CHORD 2x4 SP No.1
 BOT CHORD 2x4 SP No.1
 WEBS 2x4 SP No.3 *Except* W3:2x6 SP No.2
 SLIDER Left 2x8 SP No.2 -- 2-6-0

BRACING

TOP CHORD Structural wood sheathing directly applied or 6-0-0 oc purlins, except end verticals.
 BOT CHORD Rigid ceiling directly applied or 10-0-0 oc bracing.
 WEBS 1 Row at midpt 6-7

REACTIONS (lb/size) 2=464/0-3-8, (min. 0-1-8), 7=398/0-3-8, (min. 0-1-8)

Max Horiz 2=344 (LC 10)
 Max Uplift 2=-9 (LC 11), 7=-151 (LC 8)
 Max Grav 2=531 (LC 17), 7=579 (LC 16)

MiTek recommends that Stabilizers and required cross bracing be installed during truss erection, in accordance with Stabilizer Installation guide.

FORCES

(lb) - Max. Comp./Max. Ten. - All forces 250 (lb) or less except when shown.
 TOP CHORD 2-3=-250/31, 3-14=-453/195, 4-14=-384/233, 4-5=-308/398, 5-6=-286/460, 7-9=-420/242, 6-9=-417/240
 BOT CHORD 2-8=-357/442, 7-8=-171/297
 WEBS 4-9=-395/220

NOTES

- 1) Wind: ASCE 7-10; Vult=120mph (3-second gust) Vasd=95mph; TCDL=6.0psf; BCDL=6.0psf; h=30ft; B=20ft; L=20ft; eave=4ft; Cat. II; Exp B; Enclosed; MWFRS (directional) and C-C Exterior (2) -1-0-0 to 2-0-0, Interior (1) 2-0-0 to 10-0-4 zone; cantilever left and right exposed ; end vertical left and right exposed;C-C for members and forces & MWFRS for reactions shown; Lumber DOL=1.60 plate grip DOL=1.60
- 2) * This truss has been designed for a live load of 20.0psf on the bottom chord in all areas where a rectangle 3-06-00 tall by 2-00-00 wide will fit between the bottom chord and any other members, with BCDL = 10.0psf.
- 3) Provide mechanical connection (by others) of truss to bearing plate capable of withstanding 151 lb uplift at joint 7 and 9 lb uplift at joint 2.
- 4) This truss is designed in accordance with the 2015 International Residential Code sections R502.11.1 and R802.10.2 and referenced standard ANSI/TPI 1.

LOAD CASE(S) Standard

Job Q-2101667-1	Truss T2A	Truss Type Monopitch	Qty 1	Ply 1	Brooklyn RH V2-Roof Job Reference (optional)
--------------------	--------------	-------------------------	----------	----------	---

Peak Truss Builders LLC, New Hill, user

Run: 8.43 S Feb 3 2021 Print: 8.430 S Feb 3 2021 MiTek Industries, Inc. Wed Jul 28 08:34:40

Page: 1

ID:r1k_usmR4OMwWWHXYNV5IGz7PFv-kXeHsywpcVpOE0TV06oQbW4w3Meq06S9ay5?YybyT

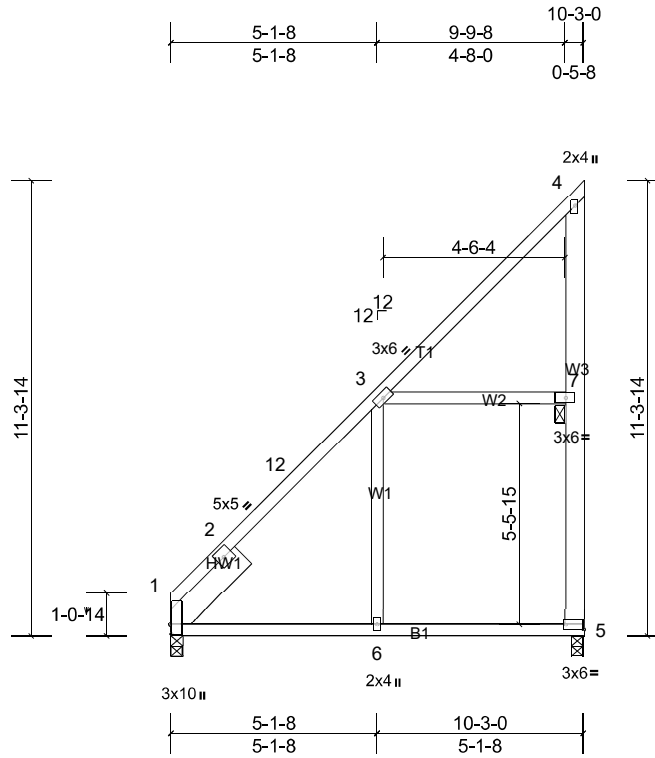

Scale = 1:57.3

Plate Offsets (X, Y): [1:0-3-0,0-0-3], [5:Edge,0-1-8]

Loading	(psf)	Spacing	2-0-0	CSI	0.92	DEFL	in	(loc)	l/defl	L/d	PLATES	GRIP
TCLL (roof)	20.0	Plate Grip DOL	1.15	TC	0.92	Vert(LL)	-0.24	6-10	>505	240	MT20	244/190
TCDL	10.0	Lumber DOL	1.15	BC	0.63	Vert(CT)	-0.38	6-10	>317	180		
BCLL	0.0*	Rep Stress Incr	YES	WB	0.18	Horz(CT)	0.11	1	n/a	n/a		
BCDL	10.0	Code	IRC2015/TPI2014	Matrix-MS							Weight: 85 lb	FT = 20%

LUMBER

TOP CHORD 2x4 SP No.1
 BOT CHORD 2x4 SP No.1
 WEBS 2x4 SP No.3 *Except* W3:2x6 SP No.2
 SLIDER Left 2x8 SP No.2 -- 2-6-0

BRACING

TOP CHORD Structural wood sheathing directly applied or 6-0-0 oc purlins, except end verticals.
 BOT CHORD Rigid ceiling directly applied or 10-0-0 oc bracing.
 WEBS 1 Row at midpt 4-5

REACTIONS (lb/size) 1=401/0-3-8, (min. 0-1-8), 5=401/0-3-8, (min. 0-1-8)
 Max Horiz 1=330 (LC 10)
 Max Uplift 5=-151 (LC 8)
 Max Grav 1=489 (LC 17), 5=582 (LC 16)

MiTek recommends that Stabilizers and required cross bracing be installed during truss erection, in accordance with Stabilizer Installation guide.

FORCES (lb) - Max. Comp./Max. Ten. - All forces 250 (lb) or less except when shown.
 TOP CHORD 1-2=-277/34, 2-12=-397/200, 3-12=-387/232, 3-4=-308/462, 5-7=-422/242, 4-7=-418/240
 BOT CHORD 1-6=-354/447, 5-6=-171/299
 WEBS 3-7=-396/221

NOTES

- Wind: ASCE 7-10; Vult=120mph (3-second gust) Vasd=95mph; TCDL=6.0psf; BCDL=6.0psf; h=30ft; B=20ft; L=20ft; eave=4ft; Cat. II; Exp B; Enclosed; MWFRS (directional) and C-C Exterior (2) 0-0-0 to 3-0-0, Interior (1) 3-0-0 to 10-0-4 zone; cantilever left and right exposed ; end vertical left and right exposed;C-C for members and forces & MWFRS for reactions shown; Lumber DOL=1.60 plate grip DOL=1.60
- * This truss has been designed for a live load of 20.0psf on the bottom chord in all areas where a rectangle 3-06-00 tall by 2-00-00 wide will fit between the bottom chord and any other members, with BCDL = 10.0psf.
- Provide mechanical connection (by others) of truss to bearing plate capable of withstanding 151 lb uplift at joint 5.
- This truss is designed in accordance with the 2015 International Residential Code sections R502.11.1 and R802.10.2 and referenced standard ANSI/TPI 1.

LOAD CASE(S) Standard

Job Q-2101667-1	Truss T3	Truss Type Piggyback Base	Qty 4	Ply 1	Brooklyn RH V2-Roof Job Reference (optional)
--------------------	-------------	------------------------------	----------	----------	---

Peak Truss Builders LLC, New Hill, user

Run: 8.43 S Feb 3 2021 Print: 8.430 S Feb 3 2021 MiTek Industries, Inc. Wed Jul 28 08:34:41

Page: 1

ID:0tNjephVYbnoBqOB7Ohv?z7PG?-CjCf3lxSNWdg?Obf36d1zo3MxTIIZMEbOEheX?ybyS

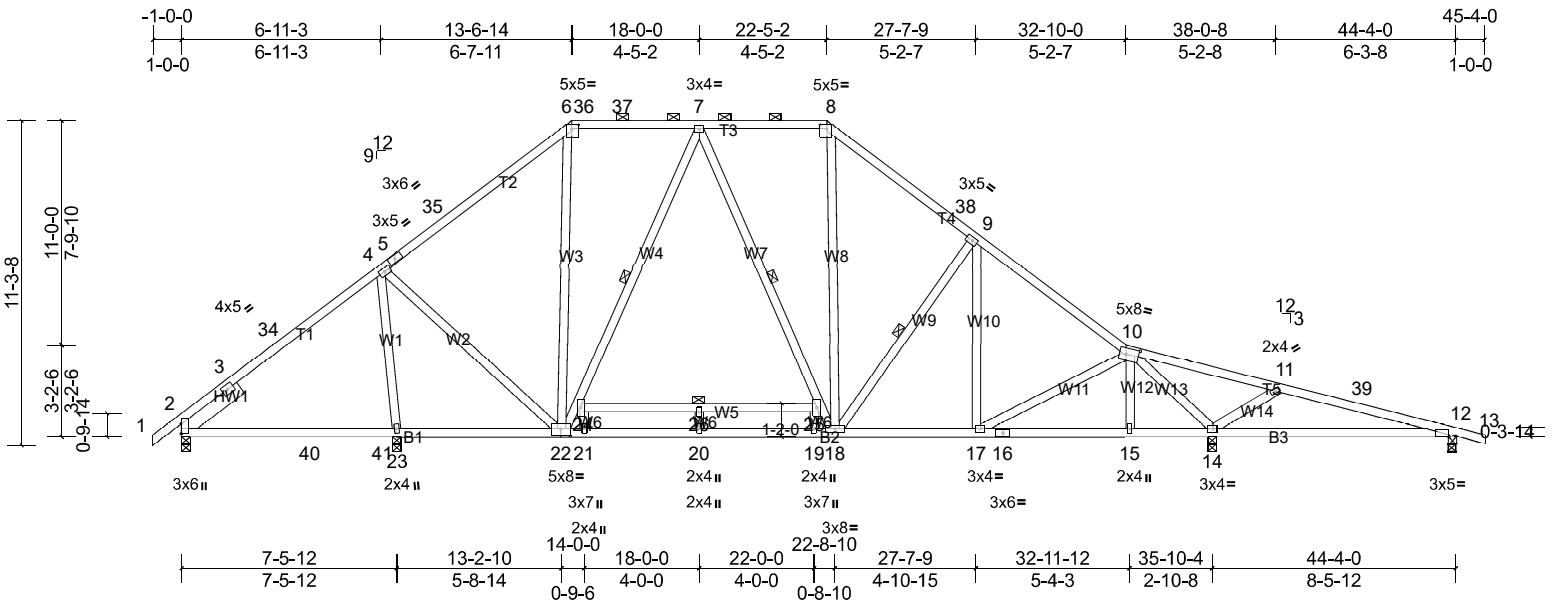

Scale = 1:80.2

Plate Offsets (X, Y): [2:Edge,0-0-0], [6:0-2-12,0-1-12], [8:0-2-12,0-1-12], [10:0-5-8,0-2-8], [12:0-3-4,Edge], [22:0-4-0,0-3-0]

Loading	(psf)	Spacing	2-0-0	CSI	DEFL	in (loc)	l/defl	L/d	PLATES	GRIP		
TCLL (roof)	20.0	Plate Grip DOL	1.15	TC	0.45	Vert(LL)	-0.05	23-29	>999	240	MT20	244/190
TCDL	10.0	Lumber DOL	1.15	BC	0.39	Vert(CT)	-0.13	14-33	>795	180		
BCLL	0.0*	Rep Stress Incr	YES	WB	0.63	Horz(CT)	0.03	14	n/a	n/a		
BCDL	10.0	Code	IRC2015/TPI2014	Matrix-MS								
											Weight: 295 lb	FT = 20%

LUMBER

TOP CHORD 2x4 SP No.1
 BOT CHORD 2x4 SP No.1
 WEBS 2x4 SP No.3
 SLIDER Left 2x6 SP No.2 -- 2-6-0

BRACING

TOP CHORD Structural wood sheathing directly applied or 5-4-11 oc purlins, except 2-0-0 oc purlins (6-0-0 max.): 6-8.
 BOT CHORD Rigid ceiling directly applied or 10-0-0 oc bracing, Except: 6-0-0 oc bracing: 12-14.
 WEBS 1 Row at midpt 7-22, 7-18, 9-18, 24-25

REACTIONS

All bearings 0-3-8.
 (lb) - Max Horiz 2--210 (LC 9)
 Max Uplift All uplift 100 (lb) or less at joint(s) 12, 23 except 2--162 (LC 11), 14--236 (LC 11)
 Max Grav All reactions 250 (lb) or less at joint(s) 12 except 2=579 (LC 23), 14=1744 (LC 1), 23=1121 (LC 1)

MiTek recommends that Stabilizers and required cross bracing be installed during truss erection, in accordance with Stabilizer Installation guide.

FORCES

(lb) - Max. Comp./Max. Ten. - All forces 250 (lb) or less except when shown.
 TOP CHORD 2-3=-323/0, 3-34=-436/183, 4-34=-388/208, 4-5=-882/245, 5-35=-864/251, 6-35=-746/294, 6-36=-597/290, 36-37=-597/290, 7-37=-597/290, 7-8=-753/293, 8-38=-955/315, 9-38=-1061/281, 9-10=-1237/243, 10-11=-106/669
 BOT CHORD 2-40=-119/480, 40-41=-32/480, 23-41=-32/480, 22-23=-52/397, 21-22=0/896, 20-21=0/897, 19-20=0/897, 18-19=0/895, 17-18=-13/927, 16-17=-36/687, 15-16=-36/687, 14-15=-34/688
 WEBS 4-23=-970/123, 4-22=0/538, 22-24=-539/0, 7-24=-439/51, 18-25=-309/0, 8-18=-82/334, 9-18=-328/155, 10-17=0/275, 10-14=-1812/300, 11-14=-546/171

NOTES

- Unbalanced roof live loads have been considered for this design.
- Wind: ASCE 7-10; Vult=120mph (3-second gust) Vasd=95mph; TCDL=6.0psf; BCDL=6.0psf; h=30ft; B=20ft; L=44ft; eave=5ft; Cat. II; Exp B; Enclosed; MWFRS (directional) and C-C Exterior (2) -1-0-0 to 3-5-3, Interior (1) 3-5-3 to 13-6-14, Exterior (2) 13-6-14 to 18-0-0, Interior (1) 18-0-0 to 22-5-2, Exterior (2) 22-5-2 to 26-10-5, Interior (1) 26-10-5 to 45-4-0 zone; cantilever left and right exposed; end vertical left and right exposed; C-C for members and forces & MWFRS for reactions shown; Lumber DOL=1.60 plate grip DOL=1.60
- Provide adequate drainage to prevent water ponding.
- * This truss has been designed for a live load of 20.0psf on the bottom chord in all areas where a rectangle 3-06-00 tall by 2-00-00 wide will fit between the bottom chord and any other members, with BCDL = 10.0psf.
- Provide mechanical connection (by others) of truss to bearing plate capable of withstanding 100 lb uplift at joint(s) 23, 12 except (jt=lb) 2=161, 14=235.
- This truss is designed in accordance with the 2015 International Residential Code sections R502.11.1 and R802.10.2 and referenced standard ANSI/TPI 1.
- Graphical purlin representation does not depict the size or the orientation of the purlin along the top and/or bottom chord.

LOAD CASE(S) Standard

Job Q-2101667-1	Truss T3A	Truss Type Piggyback Base	Qty 10	Ply 1	Brooklyn RH V2-Roof Job Reference (optional)
--------------------	--------------	------------------------------	-----------	----------	---

Peak Truss Builders LLC, New Hill, user

Run: 8.43 S Feb 3 2021 Print: 8.430 S Feb 3 2021 MiTek Industries, Inc. Wed Jul 28 08:34:41

Page: 1

ID:0tNjephVYbnoBqOB7OhV?z7PG?-CjCf3lxSNWdg?Obf36d1zo3KKTi_ZLhbOEheX?ytybS

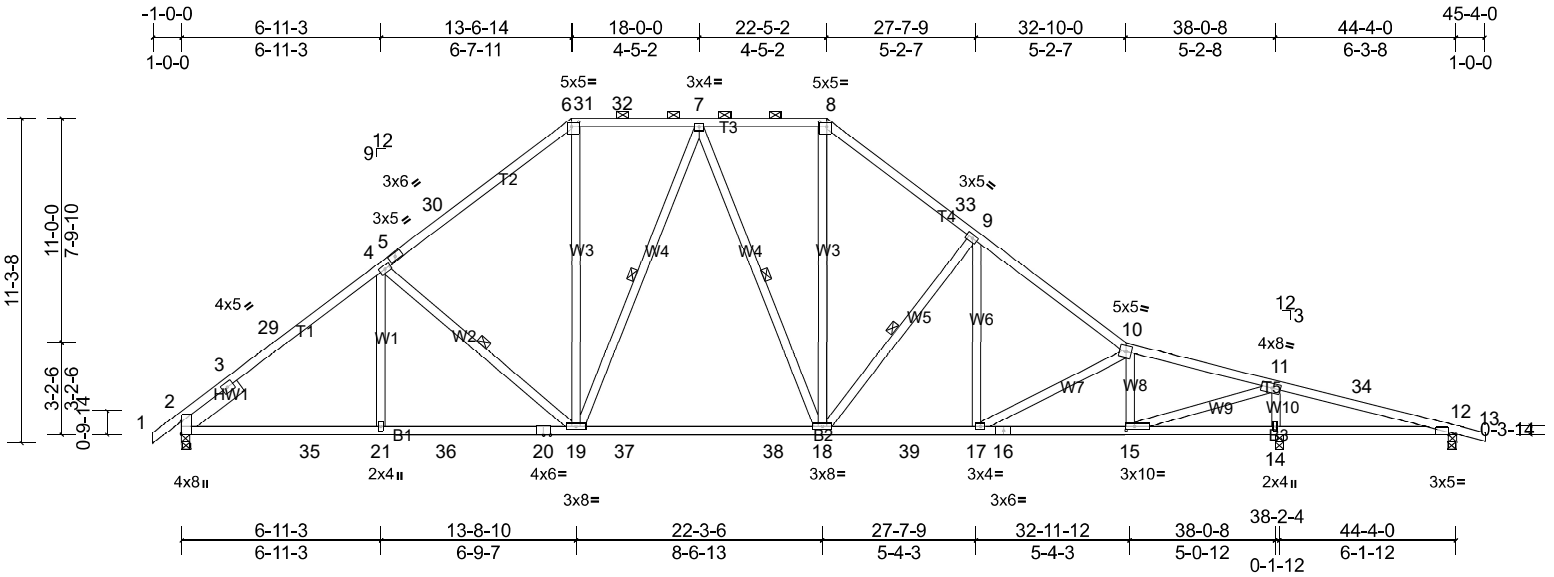

Scale = 1:80.2

Plate Offsets (X, Y): [2:Edge,0-0-0], [6:0-3-0,0-2-0], [8:0-3-0,0-2-0], [12:0-3-4,Edge], [15:0-3-8,0-1-8]

Loading	(psf)	Spacing	2-0-0	CSI	DEFL	in	(loc)	l/defl	L/d	PLATES	GRIP
TCLL (roof)	20.0	Plate Grip DOL	1.15	TC	0.62	Vert(LL)	-0.24	18-19	>999	240	MT20 244/190
TCDL	10.0	Lumber DOL	1.15	BC	0.63	Vert(CT)	-0.42	18-19	>999	180	
BCLL	0.0*	Rep Stress Incr	YES	WB	0.67	Horz(CT)	0.07	14	n/a	n/a	
BCDL	10.0	Code	IRC2015/TPI2014	Matrix-MS							Weight: 280 lb FT = 20%

LUMBER
 TOP CHORD 2x4 SP No.1
 BOT CHORD 2x4 SP No.1
 WEBS 2x4 SP No.3 *Except* W9:2x4 SP No.2
 SLIDER Left 2x6 SP No.2 -- 2-6-0

REACTIONS (lb/size) 2=1541/0-3-8, (min. 0-2-9), 12=65/0-3-8, (min. 0-1-8), 14=2061/0-3-8, (min. 0-3-4)
 Max Horiz 2=-210 (LC 9)
 Max Uplift 2=-218 (LC 11), 12=-52 (LC 8), 14=-247 (LC 11)
 Max Grav 2=1619 (LC 19), 12=84 (LC 24), 14=2061 (LC 1)

FORCES (lb) - Max. Comp./Max. Ten. - All forces 250 (lb) or less except when shown.
 TOP CHORD 2-3=-897/0, 3-29=-2077/267, 4-29=-1957/292, 4-5=-1693/287, 5-30=-1679/293, 6-30=-1588/336, 6-31=-1295/326, 31-32=-1295/326, 7-32=-1295/326, 7-8=-1313/330, 8-33=-1616/357, 9-33=-1705/323, 9-10=-2063/325, 10-11=-1970/275, 11-34=-67/847, 12-34=-80/804
 BOT CHORD 2-35=-146/1728, 21-35=-98/1728, 21-36=-98/1728, 20-36=-98/1728, 19-20=-98/1728, 19-37=0/1392, 37-38=0/1392, 18-38=0/1392, 18-39=-79/1589, 17-39=-79/1589, 16-17=-179/1911, 15-16=-179/1911, 14-15=-780/112, 12-14=-780/112
 WEBS 4-19=-487/190, 6-19=-71/684, 7-19=-301/72, 8-18=-106/748, 9-18=-567/200, 9-17=-1/315, 10-17=-386/115, 10-15=-771/159, 11-15=-297/2781, 11-14=-1875/299

- NOTES**
- Unbalanced roof live loads have been considered for this design.
 - Wind: ASCE 7-10; Vult=120mph (3-second gust) Vasd=95mph; TCDL=6.0psf; BCDL=6.0psf; h=30ft; B=20ft; L=44ft; eave=5ft; Cat. II; Exp B; Enclosed; MWFRS (directional) and C-C Exterior (2) -1-0-0 to 3-5-3, Interior (1) 3-5-3 to 13-6-14, Exterior (2) 13-6-14 to 18-0-0, Interior (1) 18-0-0 to 22-5-2, Exterior (2) 22-5-2 to 26-10-5, Interior (1) 26-10-5 to 45-4-0 zone; cantilever left and right exposed; end vertical left and right exposed; C-C for members and forces & MWFRS for reactions shown; Lumber DOL=1.60 plate grip DOL=1.60
 - Provide adequate drainage to prevent water ponding.
 - * This truss has been designed for a live load of 20.0psf on the bottom chord in all areas where a rectangle 3-06-00 tall by 2-00-00 wide will fit between the bottom chord and any other members, with BCDL = 10.0psf.
 - Provide mechanical connection (by others) of truss to bearing plate capable of withstanding 218 lb uplift at joint 2, 247 lb uplift at joint 14 and 52 lb uplift at joint 12.
 - This truss is designed in accordance with the 2015 International Residential Code sections R502.11.1 and R802.10.2 and referenced standard ANSI/TPI 1.
 - Graphical purlin representation does not depict the size or the orientation of the purlin along the top and/or bottom chord.

LOAD CASE(S) Standard

BRACING
 TOP CHORD Structural wood sheathing directly applied or 3-6-3 oc purlins, except 2-0-0 oc purlins (5-5-6 max.): 6-8.
 BOT CHORD Rigid ceiling directly applied or 10-0-0 oc bracing, Except: 6-0-0 oc bracing: 14-15,12-14.
 WEBS 1 Row at midpt 4-19, 7-19, 7-18, 9-18
 MiTek recommends that Stabilizers and required cross bracing be installed during truss erection, in accordance with Stabilizer Installation guide.

Job Q-2101667-1	Truss T3B	Truss Type Piggyback Base Structural Gable	Qty 1	Ply 1	Brooklyn RH V2-Roof Job Reference (optional)
--------------------	--------------	---	----------	----------	---

Peak Truss Builders LLC, New Hill, user

Run: 8.43 S Feb 3 2021 Print: 8.430 S Feb 3 2021 MiTek Industries, Inc. Wed Jul 28 08:34:42

Page: 1

ID:QjvNc2sRPTuHH0IrbVj_WLytcC2-gvm2Hex48piXdYArp8GV0bYst3HlnHkduRB3RtybYR

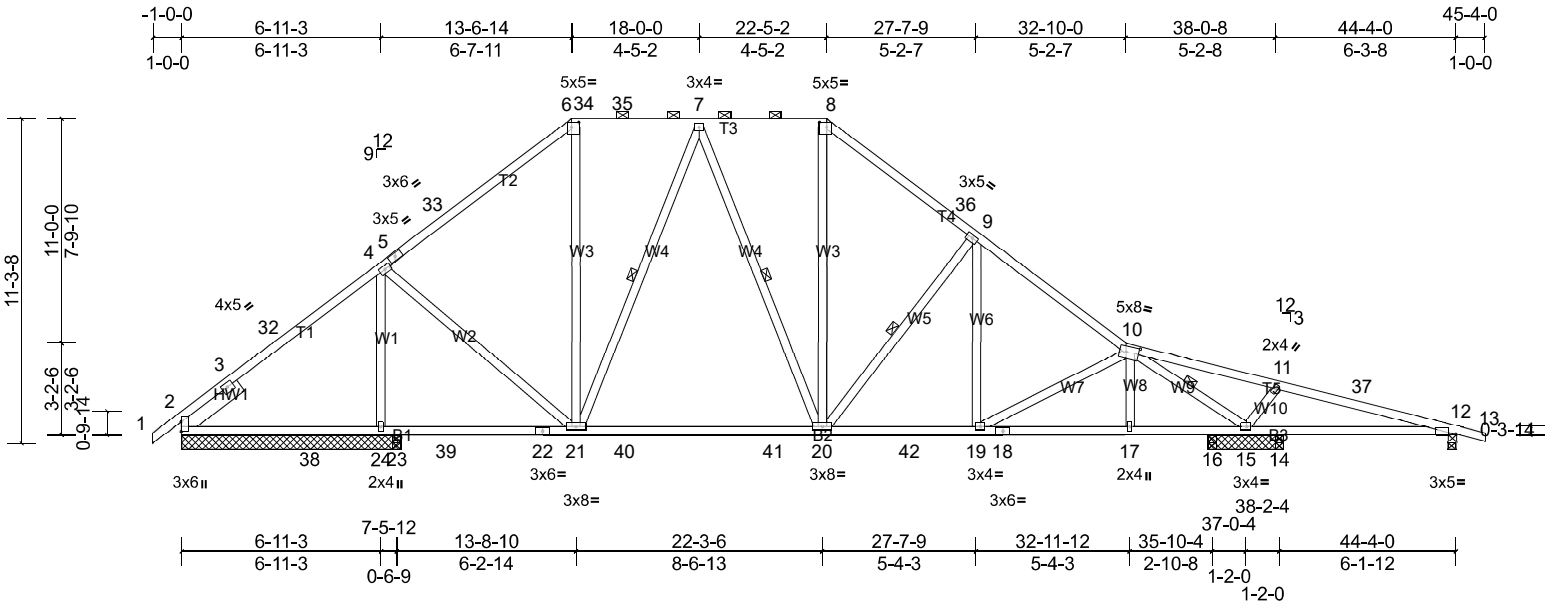

Scale = 1:80.2

Plate Offsets (X, Y): [2:Edge,0-0-0], [6:0-3-0,0-2-0], [8:0-3-0,0-2-0], [10:0-5-8,0-2-8], [12:0-3-4,Edge]

Loading	(psf)	Spacing	2-0-0	CSI	DEFL	in	(loc)	l/defl	L/d	PLATES	GRIP	
TCLL (roof)	20.0	Plate Grip DOL	1.15	TC	0.44	Vert(LL)	-0.20	20-21	>999	240	MT20	244/190
TCDL	10.0	Lumber DOL	1.15	BC	0.56	Vert(CT)	-0.33	20-21	>999	180		
BCLL	0.0*	Rep Stress Incr	YES	WB	0.71	Horz(CT)	0.04	15	n/a	n/a		
BCDL	10.0	Code	IRC2015/TPI2014	Matrix-MS								
											Weight: 280 lb	FT = 20%

LUMBER

TOP CHORD 2x4 SP No.1
 BOT CHORD 2x4 SP No.1
 WEBS 2x4 SP No.3
 SLIDER Left 2x6 SP No.2 -- 2-6-0

REACTIONS All bearings 0-3-8, except 2=7-7-8, 24=7-7-8, 25=7-7-8, 15=2-7-8
 (lb) - Max Horiz 2=-210 (LC 9), 25=-210 (LC 9)
 Max Uplift All uplift 100 (lb) or less at joint(s) 12, 16 except 2=-159 (LC 11), 15=-264 (LC 11), 23=-199 (LC 19), 24=-119 (LC 11), 25=-159 (LC 11)
 Max Grav All reactions 250 (lb) or less at joint(s) 12, 16, 23 except 2=499 (LC 23), 14=260 (LC 1), 15=1231 (LC 1), 24=1604 (LC 19), 25=499 (LC 23)

FORCES (lb) - Max. Comp./Max. Ten. - All forces 250 (lb) or less except when shown.
 TOP CHORD 3-32=-328/179, 4-32=-277/205, 4-5=-951/248, 5-33=-936/253, 6-33=-836/296, 6-34=-688/294, 34-35=-688/294, 7-35=-688/294, 7-8=-892/302, 8-36=-1094/322, 9-36=-1183/288, 9-10=-1457/275, 10-11=-68/574, 11-37=-17/377, 12-37=-31/336
 BOT CHORD 2-38=-81/344, 24-38=-81/344, 23-24=-81/344, 23-39=-81/344, 22-39=-81/344, 21-22=-81/344, 21-40=0/881, 40-41=0/881, 20-41=0/881, 20-42=-39/1106, 19-42=-39/1106, 18-19=-97/1174, 17-18=-97/1174, 16-17=-93/1175, 15-16=-93/1175, 14-15=-325/63, 12-14=-325/63
 WEBS 4-24=-1132/126, 4-21=0/672, 6-21=-48/264, 7-21=-489/58, 8-20=-85/437, 9-20=-453/180, 10-15=-2071/292, 11-15=-413/144

NOTES

- Unbalanced roof live loads have been considered for this design.
- Wind: ASCE 7-10; Vult=120mph (3-second gust) Vasd=95mph; TCDL=6.0psf; BCDL=6.0psf; h=30ft; B=20ft; L=44ft; eave=5ft; Cat. II; Exp B; Enclosed; MWFRS (directional) and C-C Exterior (2) -1-0-0 to 3-5-3, Interior (1) 3-5-3 to 13-6-14, Exterior (2) 13-6-14 to 18-0-0, Interior (1) 18-0-0 to 22-5-2, Exterior (2) 22-5-2 to 26-10-5, Interior (1) 26-10-5 to 45-4-0 zone; cantilever left and right exposed; end vertical left and right exposed; C-C for members and forces & MWFRS for reactions shown; Lumber DOL=1.60 plate grip DOL=1.60
- Provide adequate drainage to prevent water ponding.
- * This truss has been designed for a live load of 20.0psf on the bottom chord in all areas where a rectangle 3-06-00 tall by 2-00-00 wide will fit between the bottom chord and any other members, with BCDL = 10.0psf.
- Provide mechanical connection (by others) of truss to bearing plate capable of withstanding 100 lb uplift at joint(s) 12, 16 except (jt=lb) 2=159, 24=119, 15=263, 23=199, 2=159.
- This truss is designed in accordance with the 2015 International Residential Code sections R502.11.1 and R802.10.2 and referenced standard ANSI/TPI 1.
- Graphical purlin representation does not depict the size or the orientation of the purlin along the top and/or bottom chord.

LOAD CASE(S) Standard

MiTek recommends that Stabilizers and required cross bracing be installed during truss erection, in accordance with Stabilizer Installation guide.

Job Q-2101667-1	Truss T3GE	Truss Type Piggyback Base Supported Gable	Qty 1	Ply 1	Brooklyn RH V2-Roof Job Reference (optional)
--------------------	---------------	--	----------	----------	---

Peak Truss Builders LLC, New Hill, user

Run: 8.43 S Feb 3 2021 Print: 8.430 S Feb 3 2021 MiTek Industries, Inc. Wed Jul 28 08:34:42

Page: 1

ID:767CoReARJ5LJ_WcyHJIL9z7PG3-gvm2Hex48pIXdYArp8GV0bcV1AYlwCkduRB3RybyR

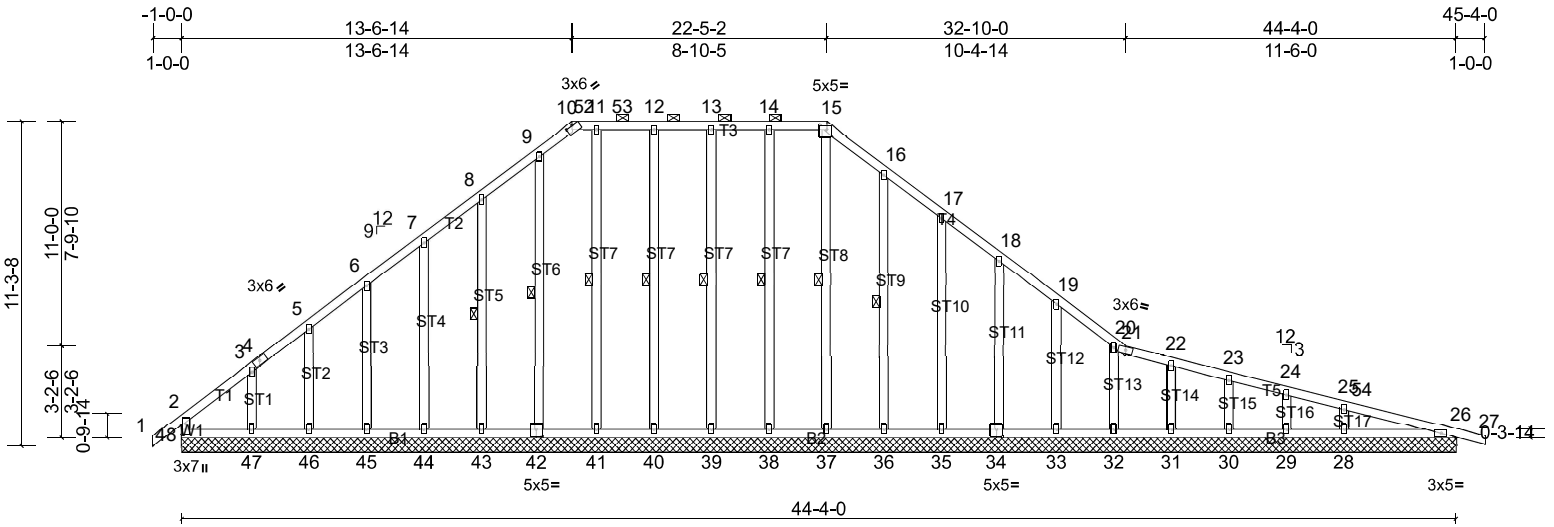

Scale = 1:80.2

Plate Offsets (X, Y): [10:0-3-0,0-0-1], [15:0-3-0,0-2-0], [34:0-2-8,0-3-0], [42:0-2-8,0-3-0], [48:0-4-8,0-1-8]

Loading	(psf)	Spacing	2-0-0	CSI	DEFL	in	(loc)	l/defl	L/d	PLATES	GRIP
TCLL (roof)	20.0	Plate Grip DOL	1.15	TC	0.14	Vert(LL)	n/a	-	n/a	999	MT20 244/190
TCDL	10.0	Lumber DOL	1.15	BC	0.09	Vert(CT)	n/a	-	n/a	999	
BCLL	0.0*	Rep Stress Incr	YES	WB	0.14	Horz(CT)	0.01	49	n/a	n/a	
BCDL	10.0	Code	IRC2015/TPI2014	Matrix-MS							Weight: 329 lb FT = 20%

LUMBER
 TOP CHORD 2x4 SP No.1
 BOT CHORD 2x4 SP No.1
 WEBS 2x4 SP No.3
 OTHERS 2x4 SP No.3

BRACING
 TOP CHORD Structural wood sheathing directly applied or 6-0-0 oc purlins, except end verticals, and 2-0-0 oc purlins (6-0-0 max.): 10-15.
 BOT CHORD Rigid ceiling directly applied or 10-0-0 oc bracing.
 WEBS 1 Row at midpt 15-37, 14-38, 13-39, 12-40, 11-41, 9-42, 8-43, 16-36

REACTIONS All bearings 44-4-0.
 (lb) - Max Horiz 48=-223 (LC 9)
 Max Uplift All uplift 100 (lb) or less at joint(s) 26, 28, 29, 30, 31, 32, 33, 34, 35, 36, 38, 39, 40, 43, 44, 45, 46, 48, 49 except 47=-108 (LC 11)
 Max Grav All reactions 250 (lb) or less at joint(s) 26, 29, 30, 31, 32, 33, 34, 35, 36, 37, 38, 39, 40, 41, 42, 43, 44, 45, 46, 47, 48, 49 except 28=301 (LC 24)

MiTek recommends that Stabilizers and required cross bracing be installed during truss erection, in accordance with Stabilizer Installation guide.

FORCES (lb) - Max. Comp./Max. Ten. - All forces 250 (lb) or less except when shown.
 TOP CHORD 9-10=-197/251, 15-16=-212/273

- NOTES**
- Unbalanced roof live loads have been considered for this design.
 - Wind: ASCE 7-10; Vult=120mph (3-second gust) Vasd=95mph; TCDL=6.0psf; BCDL=6.0psf; h=30ft; B=20ft; L=44ft; eave=2ft; Cat. II; Exp B; Enclosed; MWFRS (directional) and C-C Corner (3) -1-0-0 to 3-5-3, Exterior (2) 3-5-3 to 13-6-14, Corner (3) 13-6-14 to 18-0-1, Exterior (2) 18-0-1 to 22-5-2, Corner (3) 22-5-2 to 26-10-5, Exterior (2) 26-10-5 to 45-4-0 zone; cantilever left and right exposed; end vertical left and right exposed; C-C for members and forces & MWFRS for reactions shown; Lumber DOL=1.60 plate grip DOL=1.60
 - Truss designed for wind loads in the plane of the truss only. For studs exposed to wind (normal to the face), see Standard Industry Gable End Details as applicable, or consult qualified building designer as per ANSI/TPI 1.
 - Provide adequate drainage to prevent water ponding.
 - All plates are 2x4 MT20 unless otherwise indicated.
 - Gable requires continuous bottom chord bearing.
 - Gable studs spaced at 2-0-0 oc.
 - * This truss has been designed for a live load of 20.0psf on the bottom chord in all areas where a rectangle 3-06-00 tall by 2-00-00 wide will fit between the bottom chord and any other members.
 - Provide mechanical connection (by others) of truss to bearing plate capable of withstanding 100 lb uplift at joint(s) 48, 38, 39, 40, 43, 44, 45, 46, 36, 35, 34, 33, 32, 31, 30, 29, 28, 26, 26 except (jt=lb) 47=107.
 - This truss is designed in accordance with the 2015 International Residential Code sections R502.11.1 and R802.10.2 and referenced standard ANSI/TPI 1.
 - Graphical purlin representation does not depict the size or the orientation of the purlin along the top and/or bottom chord.

LOAD CASE(S) Standard

Job Q-2101667-1	Truss T4	Truss Type Piggyback Base	Qty 8	Ply 1	Brooklyn RH V2-Roof Job Reference (optional)
--------------------	-------------	------------------------------	----------	----------	---

Peak Truss Builders LLC, New Hill, user

Run: 8.43 S Feb 3 2021 Print: 8.430 S Feb 3 2021 MiTek Industries, Inc. Wed Jul 28 08:34:43

Page: 1

ID:YhpLQTh2kETwARFbPtSznz7PG0-86KQU_yiu7uOFil1BWFV2D8g5HPQ1LXurYAicitybQ

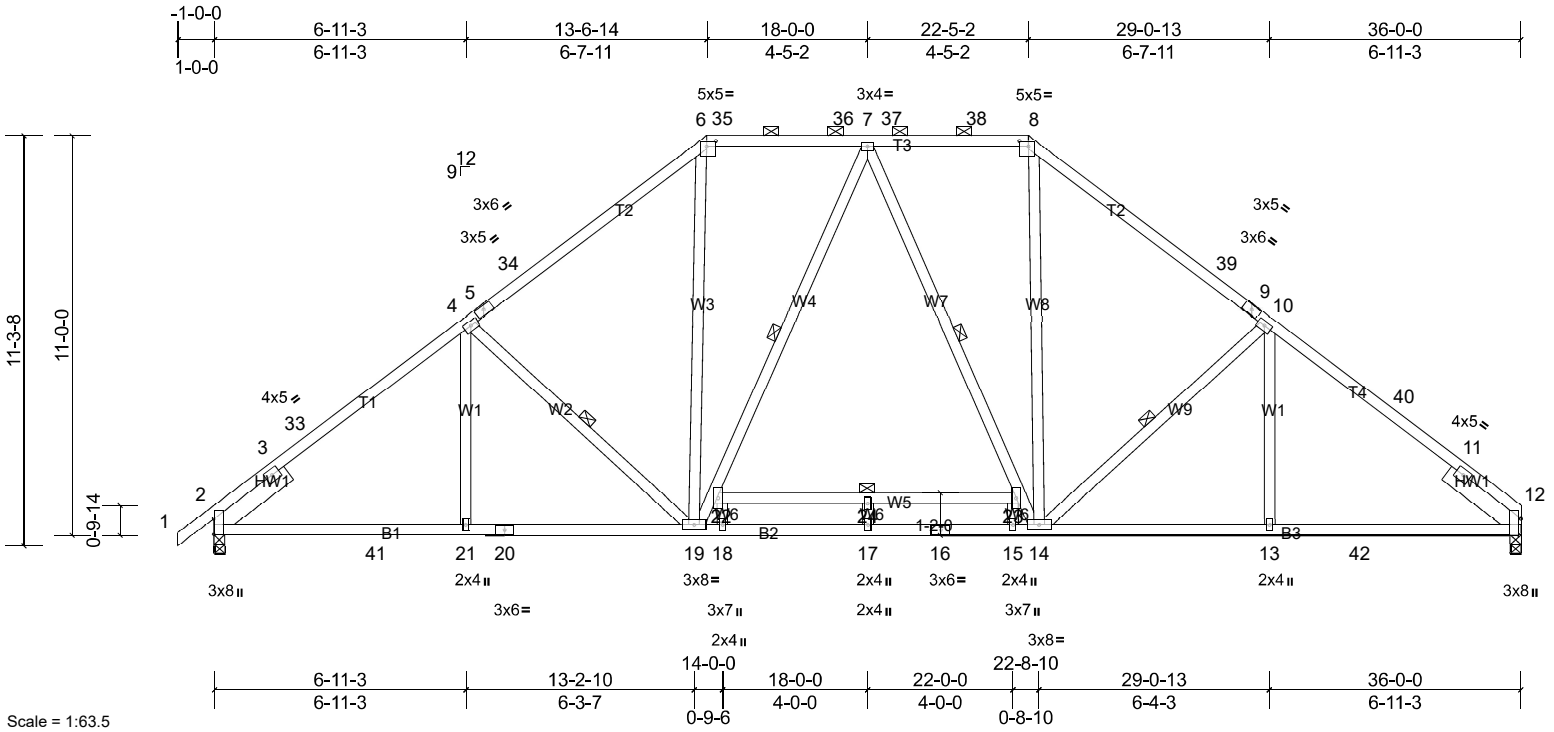

Scale = 1:63.5

Plate Offsets (X, Y): [2:Edge,0-0-0], [6:0-3-0,0-1-12], [8:0-3-0,0-1-12], [12:0-5-8,Edge]

Loading	(psf)	Spacing	2-0-0	CSI	DEFL	in	(loc)	l/defl	L/d	PLATES	GRIP
TCLL (roof)	20.0	Plate Grip DOL	1.15	TC	0.60	Vert(LL)	-0.08	17	>999	240	MT20 244/190
TCDL	10.0	Lumber DOL	1.15	BC	0.50	Vert(CT)	-0.21	17	>999	180	
BCLL	0.0*	Rep Stress Incr	YES	WB	0.26	Horz(CT)	0.08	12	n/a	n/a	
BCDL	10.0	Code	IRC2015/TPI2014	Matrix-MS							Weight: 252 lb FT = 20%

LUMBER

TOP CHORD 2x4 SP No.1
 BOT CHORD 2x4 SP No.1
 WEBS 2x4 SP No.3
 SLIDER Left 2x6 SP No.2 -- 2-6-0, Right 2x6 SP No.2 -- 2-6-0

REACTIONS (lb/size) 2=1501/0-3-8, (min. 0-2-6), 12=1439/0-3-8, (min. 0-2-4)
 Max Horiz 2=205 (LC 10)
 Max Uplift 2=-213 (LC 11), 12=-177 (LC 11)

BRACING

TOP CHORD Structural wood sheathing directly applied or 3-11-4 oc purlins, except 2-0-0 oc purlins (5-9-1 max.): 6-8.
 BOT CHORD Rigid ceiling directly applied or 10-0-0 oc bracing.
 WEBS 1 Row at midpt 4-19, 7-19, 7-14, 10-14, 22-23

MiTek recommends that Stabilizers and required cross bracing be installed during truss erection, in accordance with Stabilizer Installation guide.

FORCES (lb) - Max. Comp./Max. Ten. - All forces 250 (lb) or less except when shown.

TOP CHORD 2-3=-790/0, 3-33=-1900/252, 4-33=-1735/283, 4-5=-1587/287, 5-34=-1570/292, 6-34=-1462/335, 6-35=-1148/322, 35-36=-1148/322, 7-36=-1148/322, 7-37=-1149/323, 37-38=-1149/323, 8-38=-1149/323, 8-39=-1460/335, 9-39=-1568/292, 9-10=-1586/287, 10-40=-1740/285, 11-40=-1904/260, 11-12=-659/0
 BOT CHORD 2-41=-167/1510, 21-41=-118/1510, 20-21=-118/1510, 19-20=-118/1510, 18-19=0/1276, 17-18=0/1277, 16-17=0/1277, 15-16=0/1277, 14-15=0/1277, 13-14=-120/1451, 13-42=-120/1451, 12-42=-120/1451
 WEBS 4-19=-464/188, 6-19=-69/551, 19-22=-315/0, 7-22=-268/72, 7-23=-265/70, 14-23=-313/0, 8-14=-69/550, 10-14=-471/190

NOTES

- Unbalanced roof live loads have been considered for this design.
- Wind: ASCE 7-10; Vult=120mph (3-second gust) Vasd=95mph; TCDL=6.0psf; BCDL=6.0psf; h=30ft; B=20ft; L=36ft; eave=5ft; Cat. II; Exp B; Enclosed; MWFRS (directional) and C-C Exterior (2) -1-0-0 to 2-7-3, Interior (1) 2-7-3 to 13-6-14, Exterior (2) 13-6-14 to 18-7-15, Interior (1) 18-7-15 to 22-5-2, Exterior (2) 22-5-2 to 27-6-4, Interior (1) 27-6-4 to 36-0-0 zone; cantilever left and right exposed; end vertical left and right exposed; C-C for members and forces & MWFRS for reactions shown; Lumber DOL=1.60 plate grip DOL=1.60
- Provide adequate drainage to prevent water ponding.
- * This truss has been designed for a live load of 20.0psf on the bottom chord in all areas where a rectangle 3-06-00 tall by 2-00-00 wide will fit between the bottom chord and any other members, with BCDL = 10.0psf.
- Provide mechanical connection (by others) of truss to bearing plate capable of withstanding 213 lb uplift at joint 2 and 177 lb uplift at joint 12.
- This truss is designed in accordance with the 2015 International Residential Code sections R502.11.1 and R802.10.2 and referenced standard ANSI/TPI 1.
- Graphical purlin representation does not depict the size or the orientation of the purlin along the top and/or bottom chord.

LOAD CASE(S) Standard

Job Q-2101667-1	Truss T4AGR	Truss Type Piggyback Base Girder	Qty 1	Ply 2	Brooklyn RH V2-Roof Job Reference (optional)
--------------------	----------------	-------------------------------------	----------	----------	---

Peak Truss Builders LLC, New Hill, user

Run: 8.43 S Feb 3 2021 Print: 8.430 S Feb 3 2021 MiTek Industries, Inc. Wed Jul 28 08:34:44

Page: 1

ID:MrAchWpJ4E4uMiL_g_sC2z7PFw-cluoiKzKfR0FssKEkEAbRhXgIemprn14CwI8JybyP

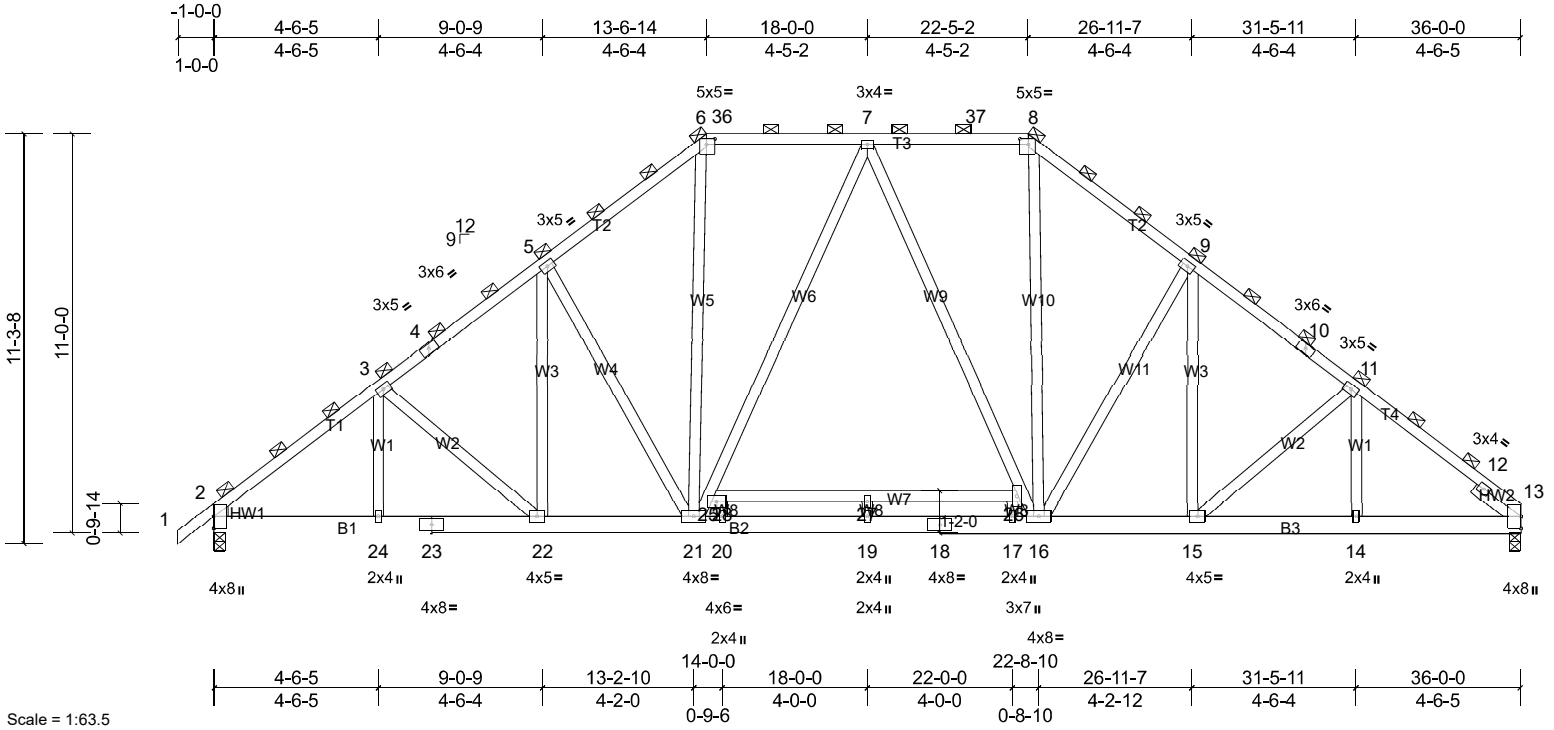

Plate Offsets (X, Y): [6:0-2-12,0-1-12], [8:0-2-12,0-1-12]

Loading	(psf)	Spacing	3-0-0	CSI	DEFL	in	(loc)	l/defl	L/d	PLATES	GRIP
TCLL (roof)	20.0	Plate Grip DOL	1.15	TC	0.24	Vert(LL)	-0.05	19	>999	240	MT20 244/190
TCDL	10.0	Lumber DOL	1.15	BC	0.50	Vert(CT)	-0.13	19	>999	180	
BCLL	0.0*	Rep Stress Incr	NO	WB	0.20	Horz(CT)	0.04	13	n/a	n/a	
BCDL	10.0	Code	IRC2015/TPI2014	Matrix-MS							Weight: 606 lb FT = 20%

LUMBER

TOP CHORD 2x4 SP No.1
 BOT CHORD 2x6 SP No.2
 WEBS 2x4 SP No.3
 WEDGE Left: 2x4 SP No.3
 SLIDER Right 2x4 SP No.3 -- 1-6-0

BRACING

TOP CHORD 2-0-0 oc purlins (6-0-0 max.)
 (Switched from sheeted: Spacing > 2-0-0).
 BOT CHORD Rigid ceiling directly applied or 10-0-0 oc bracing.

REACTIONS (lb/size) 2=2251/0-3-8, (min. 0-1-12), 13=2159/0-3-8, (min. 0-1-11)
 Max Horiz 2=307 (LC 6)
 Max Uplift 2=-319 (LC 7), 13=-265 (LC 7)

FORCES (lb) - Max. Comp./Max. Ten. - All forces 250 (lb) or less except when shown.
 TOP CHORD 2-3=-2898/396, 3-4=-2681/423, 4-5=-2572/467, 5-6=-2343/531, 6-36=-1728/477, 7-36=-1728/477, 7-37=-1734/478,
 8-37=-1734/478, 8-9=-2345/531, 9-10=-2573/468, 10-11=-2681/424, 11-12=-2894/406, 12-13=-1708/131
 BOT CHORD 2-24=-206/2209, 23-24=-206/2209, 22-23=-206/2209, 21-22=-99/2057, 20-21=0/1843, 19-20=0/1843, 18-19=0/1843,
 17-18=0/1843, 16-17=0/1846, 15-16=-100/2059, 14-15=-213/2225, 13-14=-213/2225
 WEBS 5-22=-30/295, 5-21=-622/269, 6-21=-171/965, 21-25=-446/54, 7-25=-416/105, 7-26=-410/107, 16-26=-324/23,
 8-16=-172/966, 9-16=-622/269, 9-15=-29/293, 11-15=-259/148

NOTES

- 2-ply truss to be connected together with 10d (0.131"x3") nails as follows:
 Top chords connected as follows: 2x4 - 1 row at 0-9-0 oc.
 Bottom chords connected as follows: 2x6 - 2 rows staggered at 0-9-0 oc.
 Web connected as follows: 2x4 - 1 row at 0-9-0 oc.
- All loads are considered equally applied to all plies, except if noted as front (F) or back (B) face in the LOAD CASE(S) section. Ply to ply connections have been provided to distribute only loads noted as (F) or (B), unless otherwise indicated.
- Unbalanced roof live loads have been considered for this design.
- Wind: ASCE 7-10; Vult=120mph (3-second gust) Vasd=95mph; TCDL=6.0psf; BCDL=6.0psf; h=30ft; B=20ft; L=36ft; eave=5ft; Cat. II; Exp B; Enclosed; MWFRS (directional); cantilever left and right exposed; end vertical left and right exposed; Lumber DOL=1.60 plate grip DOL=1.60
- Provide adequate drainage to prevent water ponding.
- * This truss has been designed for a live load of 20.0psf on the bottom chord in all areas where a rectangle 3-06-00 tall by 2-00-00 wide will fit between the bottom chord and any other members.
- Provide mechanical connection (by others) of truss to bearing plate capable of withstanding 319 lb uplift at joint 2 and 265 lb uplift at joint 13.
- This truss is designed in accordance with the 2015 International Residential Code sections R502.11.1 and R802.10.2 and referenced standard ANSI/TPI 1.
- Graphical purlin representation does not depict the size or the orientation of the purlin along the top and/or bottom chord.

LOAD CASE(S) Standard

Job Q-2101667-1	Truss T4BGRD	Truss Type Piggyback Base Girder	Qty 1	Ply 2	Brooklyn RH V2-Roof Job Reference (optional)
--------------------	-----------------	-------------------------------------	----------	----------	---

Peak Truss Builders LLC, New Hill, user

Run: 8.43 S Feb 3 2021 Print: 8.430 S Feb 3 2021 MiTek Industries, Inc. Wed Jul 28 08:34:44

Page: 1

ID:MrAchWlpJ4E4uMil_g_sC2z7PFw-cluoiKzKfR0FssKkEAKbRhughtmnr14CwI8JybyP

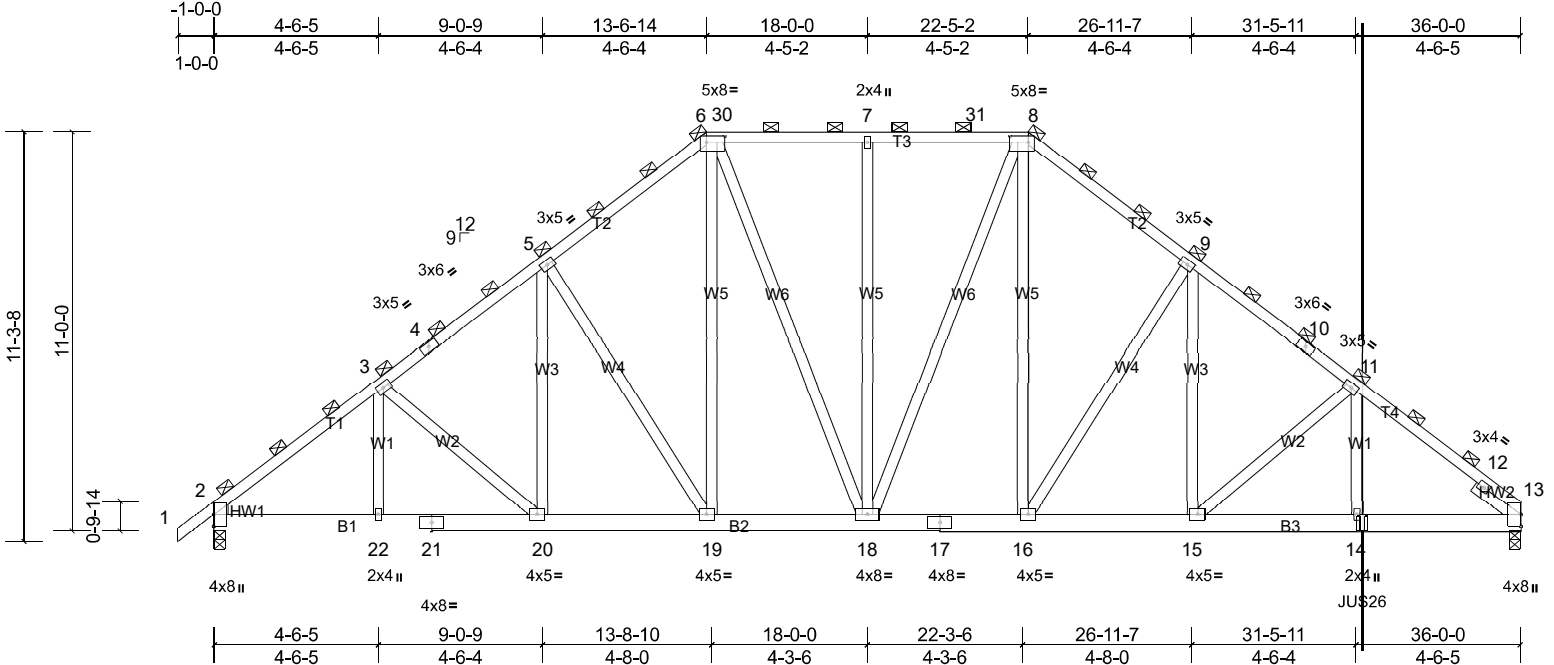

Scale = 1:63.5

Plate Offsets (X, Y): [6:0-6-0,0-2-0], [8:0-6-0,0-2-0]

Loading	(psf)	Spacing	4-0-0	CSI	DEFL	in	(loc)	l/defl	L/d	PLATES	GRIP
TCLL (roof)	20.0	Plate Grip DOL	1.15	TC	0.42	Vert(LL)	-0.07	16	>999	240	MT20 244/190
TCDL	10.0	Lumber DOL	1.15	BC	0.74	Vert(CT)	-0.14	15-16	>999	180	
BCLL	0.0*	Rep Stress Incr	NO	WB	0.35	Horz(CT)	0.06	13	n/a	n/a	
BCDL	10.0	Code	IRC2015/TPI2014	Matrix-MS							Weight: 607 lb FT = 20%

LUMBER

TOP CHORD 2x4 SP No.1
 BOT CHORD 2x6 SP No.2
 WEBS 2x4 SP No.3
 WEDGE Left: 2x4 SP No.3
 SLIDER Right 2x4 SP No.3 -- 1-6-0

BRACING

TOP CHORD 2-0-0 oc purlins (5-7-9 max.)
 (Switched from sheeted: Spacing > 2-0-0).
 BOT CHORD Rigid ceiling directly applied or 10-0-0 oc bracing.

REACTIONS (lb/size) 2=3087/0-3-8, (min. 0-2-7), 13=3475/0-3-8, (min. 0-2-12)
 Max Horiz 2=410 (LC 6)
 Max Uplift 2=-448 (LC 7), 13=-513 (LC 7)

FORCES (lb) - Max. Comp./Max. Ten. - All forces 250 (lb) or less except when shown.
 TOP CHORD 2-3=-3984/562, 3-4=-3719/597, 4-5=-3574/655, 5-6=-3194/738, 6-30=-2610/701, 7-31=-2610/701, 8-31=-2610/701, 8-9=-3282/762, 9-10=-3849/729, 10-11=-3987/684, 11-12=-4711/772, 12-13=-2827/321
 BOT CHORD 2-22=-303/3041, 21-22=-303/3041, 20-21=-303/3041, 19-20=-158/2859, 18-19=0/2414, 17-18=0/2486, 16-17=0/2486, 15-16=-218/3079, 14-15=-466/3638, 13-14=-466/3638
 WEBS 3-20=-295/200, 5-20=-15/455, 5-19=-878/337, 6-19=-176/894, 6-18=-106/737, 7-18=-593/198, 8-18=-131/551, 8-16=-235/1139, 9-16=-1175/410, 9-15=-102/813, 11-15=-823/324, 11-14=-98/592

NOTES

- 2-ply truss to be connected together with 10d (0.131"x3") nails as follows:
 Top chords connected as follows: 2x4 - 1 row at 0-9-0 oc.
 Bottom chords connected as follows: 2x6 - 2 rows staggered at 0-9-0 oc.
 Web connected as follows: 2x4 - 1 row at 0-9-0 oc.
- All loads are considered equally applied to all plies, except if noted as front (F) or back (B) face in the LOAD CASE(S) section. Ply to ply connections have been provided to distribute only loads noted as (F) or (B), unless otherwise indicated.
- Unbalanced roof live loads have been considered for this design.
- Wind: ASCE 7-10; Vult=120mph (3-second gust) Vasd=95mph; TCDL=6.0psf; BCDL=6.0psf; h=30ft; B=20ft; L=36ft; eave=5ft; Cat. II; Exp B; Enclosed; MWFRS (directional); cantilever left and right exposed; end vertical left and right exposed; Lumber DOL=1.60 plate grip DOL=1.60
- Provide adequate drainage to prevent water ponding.
- * This truss has been designed for a live load of 20.0psf on the bottom chord in all areas where a rectangle 3-06-00 tall by 2-00-00 wide will fit between the bottom chord and any other members.
- Provide mechanical connection (by others) of truss to bearing plate capable of withstanding 448 lb uplift at joint 2 and 513 lb uplift at joint 13.
- This truss is designed in accordance with the 2015 International Residential Code sections R502.11.1 and R802.10.2 and referenced standard ANSI/TPI 1.
- Graphical purlin representation does not depict the size or the orientation of the purlin along the top and/or bottom chord.
- Use USP JUS26 (With 4-10d nails into Girder & 4-10d nails into Truss) or equivalent at 31-7-12 from the left end to connect truss(es) T7GRD (1 ply 2x6 SP) to back face of bottom chord.
- Fill all nail holes where hanger is in contact with lumber.

LOAD CASE(S) Standard

- Dead + Roof Live (balanced): Lumber Increase=1.15, Plate Increase=1.15
 Uniform Loads (lb/ft)

Job	Truss	Truss Type	Qty	Ply	Brooklyn RH V2-Roof
Q-2101667-1	T4BGRD	Piggyback Base Girder	1	2	Job Reference (optional)

Peak Truss Builders LLC, New Hill, user

Run: 8.43 S Feb 3 2021 Print: 8.430 S Feb 3 2021 MiTek Industries, Inc. Wed Jul 28 08:34:44

Page: 2

ID:MrAchWlpJ4E4uMiL_g_sC2z7PFw-cluoiKzKfR0FssKEkEakbRhuightmnR14CwI8JybyP

Vert: 1-6=-120, 6-8=-120, 8-13=-120, 23-26=-40

Concentrated Loads (lb)

Vert: 14=-683 (B)

Job Q-2101667-1	Truss T4GE	Truss Type Piggyback Base Supported Gable	Qty 1	Ply 1	Brooklyn RH V2-Roof Job Reference (optional)
--------------------	---------------	--	----------	----------	---

Peak Truss Builders LLC, New Hill, user

Run: 8.43 S Feb 3 2021 Print: 8.430 S Feb 3 2021 MiTek Industries, Inc. Wed Jul 28 08:34:45

Page: 1

ID:r1k_usmR4OMwWWHXYNV5IGz7PFv-4USAvg_yQk86U0uQlxiz7eD7s4CuVH_BJsfrgmytbyO

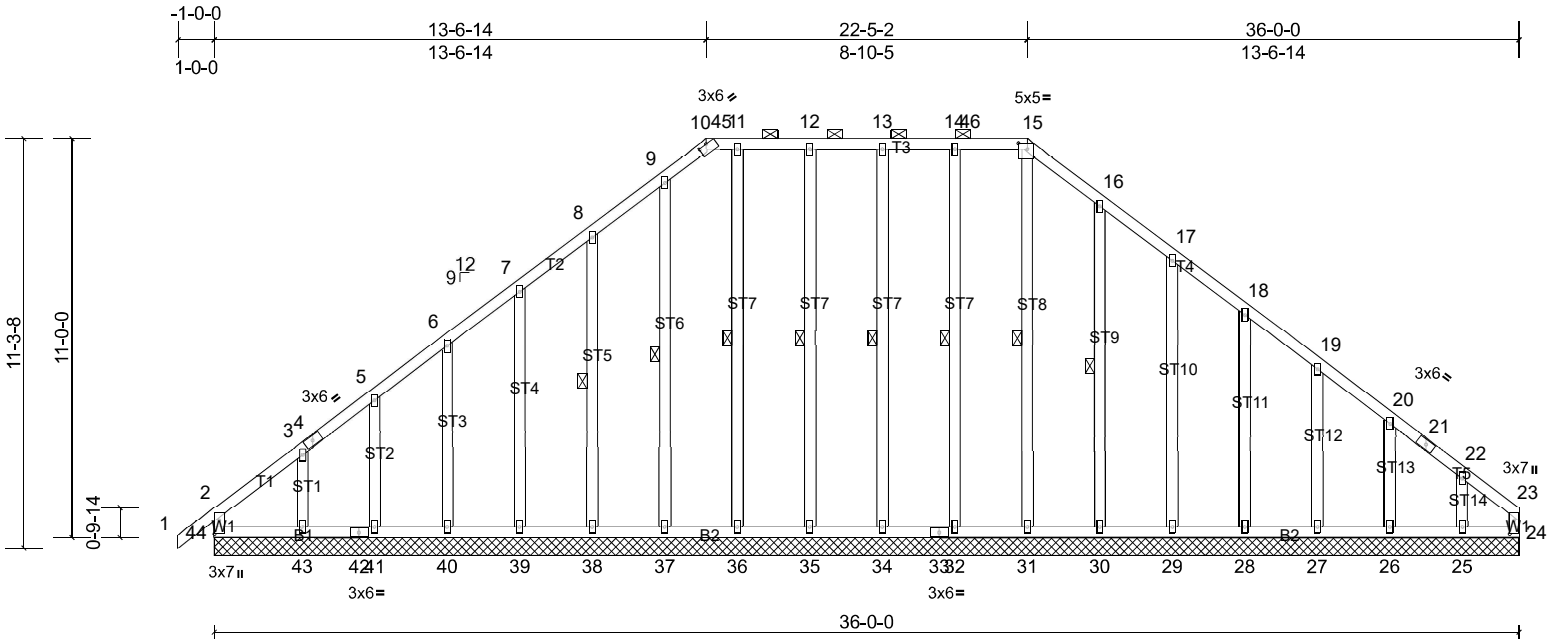

Scale = 1:63.6

Plate Offsets (X, Y): [10:0-3-0,0-0-1], [15:0-3-0,0-2-0], [23:0-4-8,0-1-8], [44:0-4-8,0-1-8]

Loading	(psf)	Spacing	2-0-0	CSI	DEFL	in	(loc)	l/defl	L/d	PLATES	GRIP	
TCLL (roof)	20.0	Plate Grip DOL	1.15	TC	0.14	Vert(LL)	n/a	-	n/a	999	MT20	244/190
TCDL	10.0	Lumber DOL	1.15	BC	0.05	Vert(CT)	n/a	-	n/a	999		
BCLL	0.0*	Rep Stress Incr	YES	WB	0.14	Horz(CT)	0.01	24	n/a	n/a		
BCDL	10.0	Code	IRC2015/TPI2014	Matrix-MR								Weight: 297 lb FT = 20%

LUMBER
 TOP CHORD 2x4 SP No.1
 BOT CHORD 2x4 SP No.1
 WEBS 2x4 SP No.3
 OTHERS 2x4 SP No.3

BRACING
 TOP CHORD Structural wood sheathing directly applied or 6-0-0 oc purlins, except end verticals, and 2-0-0 oc purlins (6-0-0 max.): 10-15.
 BOT CHORD Rigid ceiling directly applied or 10-0-0 oc bracing.
 WEBS 1 Row at midpt 15-31, 14-32, 13-34, 12-35, 11-36, 9-37, 8-38, 16-30

REACTIONS All bearings 36-0-0.
 (lb) - Max Horiz 44=220 (LC 10)
 Max Uplift All uplift 100 (lb) or less at joint(s) 24, 26, 27, 28, 29, 30, 32, 34, 35, 38, 39, 40, 41, 44 except 25=115 (LC 11), 43=105 (LC 11)
 Max Grav All reactions 250 (lb) or less at joint(s) 24, 25, 26, 27, 28, 29, 30, 31, 32, 34, 35, 36, 37, 38, 39, 40, 41, 43, 44

MiTek recommends that Stabilizers and required cross bracing be installed during truss erection, in accordance with Stabilizer Installation guide.

FORCES (lb) - Max. Comp./Max. Ten. - All forces 250 (lb) or less except when shown.
 TOP CHORD 8-9=-216/256, 9-10=-219/259, 15-16=-236/283

- NOTES**
- Unbalanced roof live loads have been considered for this design.
 - Wind: ASCE 7-10; Vult=120mph (3-second gust) Vasd=95mph; TCDL=6.0psf; BCDL=6.0psf; h=30ft; B=20ft; L=36ft; eave=2ft; Cat. II; Exp B; Enclosed; MWFRS (directional) and C-C Corner (3) -1-0-0 to 2-5-2, Exterior (2) 2-5-2 to 13-6-14, Corner (3) 13-6-14 to 17-2-1, Exterior (2) 17-2-1 to 22-5-2, Corner (3) 22-5-2 to 26-0-5, Exterior (2) 26-0-5 to 35-10-4 zone; cantilever left and right exposed; end vertical left and right exposed; C-C for members and forces & MWFRS for reactions shown; Lumber DOL=1.60 plate grip DOL=1.60
 - Truss designed for wind loads in the plane of the truss only. For studs exposed to wind (normal to the face), see Standard Industry Gable End Details as applicable, or consult qualified building designer as per ANSI/TPI 1.
 - Provide adequate drainage to prevent water ponding.
 - All plates are 2x4 MT20 unless otherwise indicated.
 - Gable requires continuous bottom chord bearing.
 - Truss to be fully sheathed from one face or securely braced against lateral movement (i.e. diagonal web).
 - Gable studs spaced at 2-0-0 oc.
 - * This truss has been designed for a live load of 20.0psf on the bottom chord in all areas where a rectangle 3-06-00 tall by 2-00-00 wide will fit between the bottom chord and any other members.
 - Provide mechanical connection (by others) of truss to bearing plate capable of withstanding 100 lb uplift at joint(s) 44, 24, 32, 34, 35, 38, 39, 40, 41, 30, 29, 28, 27, 26 except (jt=lb) 43=104, 25=115.
 - This truss is designed in accordance with the 2015 International Residential Code sections R502.11.1 and R802.10.2 and referenced standard ANSI/TPI 1.
 - Graphical purlin representation does not depict the size or the orientation of the purlin along the top and/or bottom chord.

LOAD CASE(S) Standard

Job Q-2101667-1	Truss T4GRD	Truss Type Piggyback Base Girder	Qty 1	Ply 2	Brooklyn RH V2-Roof Job Reference (optional)
--------------------	----------------	-------------------------------------	----------	----------	---

Peak Truss Builders LLC, New Hill, user

Run: 8.43 S Feb 3 2021 Print: 8.430 S Feb 3 2021 MiTek Industries, Inc. Wed Jul 28 08:34:45

Page: 1

ID:MrAchWlpJ4E4uMIL_g_sC2z7PFw-4USAvg_yQk86U0uQlxiz7eD4_439VFbBJSfrgmytbyO

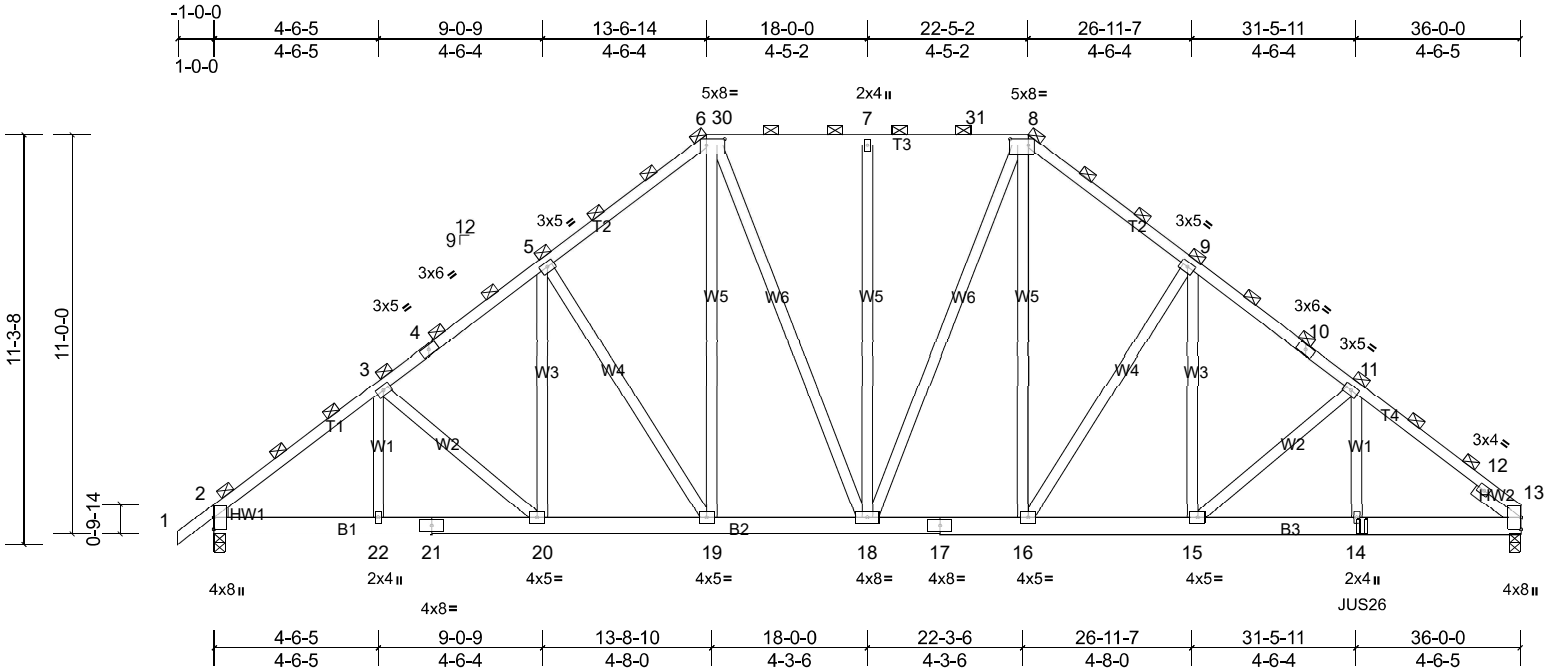

Scale = 1:63.5

Plate Offsets (X, Y): [6:0-6-0,0-2-0], [8:0-6-0,0-2-0]

Loading	(psf)	Spacing	3-0-0	CSI	DEFL	in	(loc)	l/defl	L/d	PLATES	GRIP
TCLL (roof)	20.0	Plate Grip DOL	1.15	TC	0.32	Vert(LL)	-0.05	16	>999	240	MT20 244/190
TCDL	10.0	Lumber DOL	1.15	BC	0.61	Vert(CT)	-0.11	15-16	>999	180	
BCLL	0.0*	Rep Stress Incr	NO	WB	0.29	Horz(CT)	0.05	13	n/a	n/a	
BCDL	10.0	Code	IRC2015/TPI2014	Matrix-MS							Weight: 607 lb FT = 20%

LUMBER

TOP CHORD 2x4 SP No.1
 BOT CHORD 2x6 SP No.2
 WEBS 2x4 SP No.3
 WEDGE Left: 2x4 SP No.3
 SLIDER Right 2x4 SP No.3 -- 1-6-0

BRACING

TOP CHORD 2-0-0 oc purlins (6-0-0 max.)
 (Switched from sheeted: Spacing > 2-0-0).
 BOT CHORD Rigid ceiling directly applied or 10-0-0 oc bracing.

REACTIONS (lb/size) 2=2344/0-3-8, (min. 0-1-13), 13=2806/0-3-8, (min. 0-2-3)
 Max Horiz 2=307 (LC 6)
 Max Uplift 2=-342 (LC 7), 13=-425 (LC 7)

FORCES (lb) - Max. Comp./Max. Ten. - All forces 250 (lb) or less except when shown.
 TOP CHORD 2-3=-3030/430, 3-4=-2834/457, 4-5=-2726/501, 5-6=-2442/563, 6-30=-2006/535, 7-31=-2006/535,
 8-31=-2006/535, 8-9=-2536/586, 9-10=-3023/574, 10-11=-3125/540, 11-12=-3820/637, 12-13=-2305/278
 BOT CHORD 2-22=-234/2313, 21-22=-234/2313, 20-21=-234/2313, 19-20=-126/2181, 18-19=0/1847, 17-18=-11/1925, 16-17=-11/1925,
 15-16=-185/2418, 14-15=-395/2955, 13-14=-395/2955
 WEBS 5-20=-13/340, 5-19=-657/253, 6-19=-133/669, 6-18=-86/584, 7-18=-445/148, 8-18=-115/383, 8-16=-191/932,
 9-16=-978/326, 9-15=-98/727, 11-15=-781/274, 11-14=-113/653

NOTES

- 2-ply truss to be connected together with 10d (0.131"x3") nails as follows:
 Top chords connected as follows: 2x4 - 1 row at 0-9-0 oc.
 Bottom chords connected as follows: 2x6 - 2 rows staggered at 0-9-0 oc.
 Web connected as follows: 2x4 - 1 row at 0-9-0 oc.
- All loads are considered equally applied to all plies, except if noted as front (F) or back (B) face in the LOAD CASE(S) section. Ply to ply connections have been provided to distribute only loads noted as (F) or (B), unless otherwise indicated.
- Unbalanced roof live loads have been considered for this design.
- Wind: ASCE 7-10; Vult=120mph (3-second gust) Vasd=95mph; TCDL=6.0psf; BCDL=6.0psf; h=30ft; B=20ft; L=36ft; eave=5ft; Cat. II; Exp B; Enclosed; MWFRS (directional); cantilever left and right exposed; end vertical left and right exposed; Lumber DOL=1.60 plate grip DOL=1.60
- Provide adequate drainage to prevent water ponding.
- * This truss has been designed for a live load of 20.0psf on the bottom chord in all areas where a rectangle 3-06-00 tall by 2-00-00 wide will fit between the bottom chord and any other members.
- Provide mechanical connection (by others) of truss to bearing plate capable of withstanding 342 lb uplift at joint 2 and 425 lb uplift at joint 13.
- This truss is designed in accordance with the 2015 International Residential Code sections R502.11.1 and R802.10.2 and referenced standard ANSI/TPI 1.
- Graphical purlin representation does not depict the size or the orientation of the purlin along the top and/or bottom chord.
- Use USP JUS26 (With 4-10d nails into Girder & 4-10d nails into Truss) or equivalent at 31-7-12 from the left end to connect truss(es) T7GRD (1 ply 2x6 SP) to front face of bottom chord.
- Fill all nail holes where hanger is in contact with lumber.

LOAD CASE(S) Standard

- Dead + Roof Live (balanced): Lumber Increase=1.15, Plate Increase=1.15
 Uniform Loads (lb/ft)

Job Q-2101667-1	Truss T4GRD	Truss Type Piggyback Base Girder	Qty 1	Ply 2	Brooklyn RH V2-Roof Job Reference (optional)
--------------------	----------------	-------------------------------------	----------	----------	---

Peak Truss Builders LLC, New Hill, user

Run: 8.43 S Feb 3 2021 Print: 8.430 S Feb 3 2021 MiTek Industries, Inc. Wed Jul 28 08:34:45

Page: 2

ID:MrAchWlpJ4E4uMIL_g_sC2z7PFw-4USAvg_yQk86U0uQixiz7eD4_439VFbBjsfrgmytbyO

Vert: 1-6=-90, 6-8=-90, 8-13=-90, 23-26=-30
Concentrated Loads (lb)
Vert: 14=-741 (F)

Job Q-2101667-1	Truss T5	Truss Type Piggyback Base	Qty 1	Ply 1	Brooklyn RH V2-Roof Job Reference (optional)
--------------------	-------------	------------------------------	----------	----------	---

Peak Truss Builders LLC, New Hill, user

Run: 8.43 S Feb 3 2021 Print: 8.430 S Feb 3 2021 MiTek Industries, Inc. Wed Jul 28 08:34:46

Page: 1

ID:MqViSwg1xG?PzjzDsyTPBytcCH-Yh?Y60?aB2Gz69TcsfDCgsmDQU8EejKYWPPCCybyN

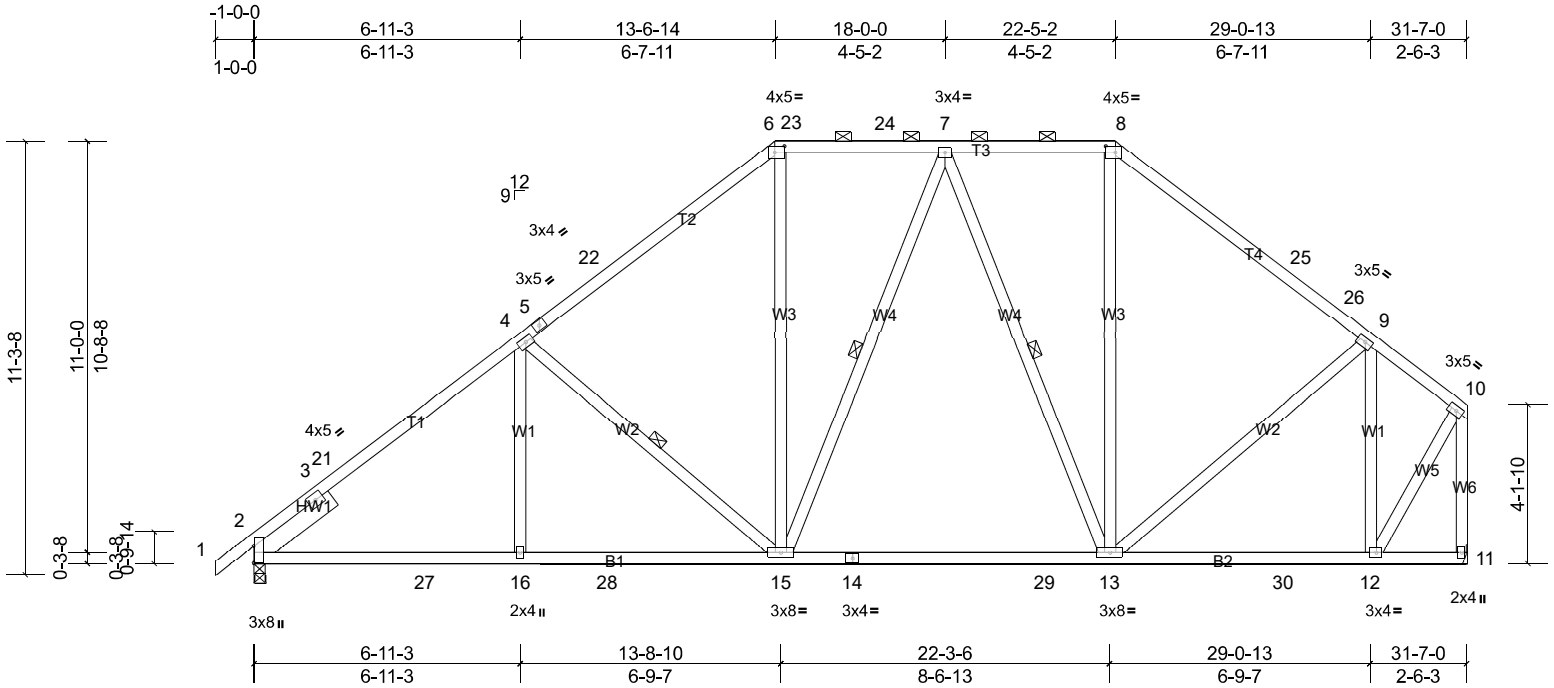

Scale = 1:60

Plate Offsets (X, Y): [2:Edge,0-0-0], [6:0-3-0,0-2-0], [8:0-3-0,0-2-0]

Loading	(psf)	Spacing	2-0-0	CSI	DEFL	in	(loc)	l/defl	L/d	PLATES	GRIP	
TCLL (roof)	20.0	Plate Grip DOL	1.15	TC	0.47	Vert(LL)	-0.21	13-15	>999	240	MT20	244/190
TCDL	10.0	Lumber DOL	1.15	BC	0.56	Vert(CT)	-0.33	13-15	>999	180		
BCLL	0.0*	Rep Stress Incr	YES	WB	0.49	Horz(CT)	0.04	11	n/a	n/a		
BCDL	10.0	Code	IRC2015/TPI2014	Matrix-MS								
											Weight: 229 lb	FT = 20%

LUMBER

TOP CHORD 2x4 SP No.1
 BOT CHORD 2x4 SP No.1
 WEBS 2x4 SP No.3
 SLIDER Left 2x6 SP No.2 -- 2-6-0

BRACING

TOP CHORD Structural wood sheathing directly applied or 4-5-9 oc purlins, except end verticals, and 2-0-0 oc purlins (6-0-0 max.): 6-8.
 BOT CHORD Rigid ceiling directly applied or 10-0-0 oc bracing, Except: 6-0-0 oc bracing: 11-12.
 WEBS 1 Row at midpt 4-15, 7-15, 7-13

REACTIONS (lb/size) 2=1318/0-3-8, (min. 0-2-3), 11=1257/ Mechanical, (min. 0-1-8)
 Max Horiz 2=255 (LC 10)
 Max Uplift 2=-187 (LC 11), 11=-158 (LC 11)
 Max Grav 2=1386 (LC 19), 11=1290 (LC 20)

MiTek recommends that Stabilizers and required cross bracing be installed during truss erection, in accordance with Stabilizer Installation guide.

FORCES

(lb) - Max. Comp./Max. Ten. - All forces 250 (lb) or less except when shown.
 TOP CHORD 2-3=-754/0, 3-21=-1728/210, 4-21=-1675/245, 4-5=-1331/238, 5-22=-1316/243, 6-22=-1224/287, 6-23=-999/286, 23-24=-999/286, 7-24=-999/286, 7-8=-839/267, 8-25=-1025/259, 25-26=-1068/227, 9-26=-1133/216, 9-10=-689/134, 10-11=-1285/165
 BOT CHORD 2-27=-220/1435, 16-27=-162/1435, 16-28=-162/1435, 15-28=-162/1435, 14-15=-67/998, 14-29=-67/998, 13-29=-67/998, 13-30=-78/559, 12-30=-78/559
 WEBS 4-15=-503/193, 6-15=-40/466, 7-13=-406/72, 8-13=-19/375, 9-13=-10/407, 9-12=-775/159, 10-12=-120/1047

NOTES

- Unbalanced roof live loads have been considered for this design.
- Wind: ASCE 7-10; Vult=120mph (3-second gust) Vasd=95mph; TCDL=6.0psf; BCDL=6.0psf; h=30ft; B=20ft; L=32ft; eave=4ft; Cat. II; Exp B; Enclosed; MWFRS (directional) and C-C Exterior (2) -1-0-0 to 2-1-14, Interior (1) 2-1-14 to 13-6-14, Exterior (2) 13-6-14 to 18-0-0, Interior (1) 18-0-0 to 22-5-2, Exterior (2) 22-5-2 to 26-10-12, Interior (1) 26-10-12 to 31-5-4 zone; cantilever left and right exposed; end vertical left and right exposed; C-C for members and forces & MWFRS for reactions shown; Lumber DOL=1.60 plate grip DOL=1.60
- Provide adequate drainage to prevent water ponding.
- * This truss has been designed for a live load of 20.0psf on the bottom chord in all areas where a rectangle 3-06-00 tall by 2-00-00 wide will fit between the bottom chord and any other members, with BCDL = 10.0psf.
- Refer to girder(s) for truss to truss connections.
- Provide mechanical connection (by others) of truss to bearing plate capable of withstanding 187 lb uplift at joint 2 and 158 lb uplift at joint 11.
- This truss is designed in accordance with the 2015 International Residential Code sections R502.11.1 and R802.10.2 and referenced standard ANSI/TPI 1.
- Graphical purlin representation does not depict the size or the orientation of the purlin along the top and/or bottom chord.

LOAD CASE(S) Standard

Job Q-2101667-1	Truss T6	Truss Type Monopitch	Qty 4	Ply 1	Brooklyn RH V2-Roof Job Reference (optional)
--------------------	-------------	-------------------------	----------	----------	---

Peak Truss Builders LLC, New Hill, user

Run: 8.43 S Feb 3 2021 Print: 8.430 S Feb 3 2021 MiTek Industries, Inc. Wed Jul 28 08:34:46

Page: 1

ID:8VteJ3uf_Za6gbz4RFmbwHz7PMC-Yh?Y60?aB2Gz69TcsDCgsmAgUTSEkkKYWPPCCybyN

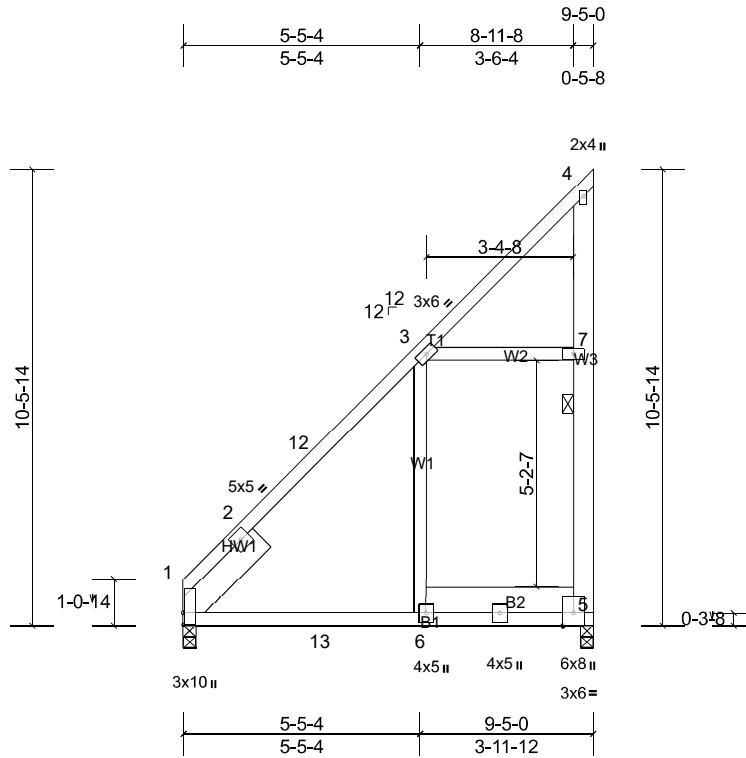

Scale = 1:53

Plate Offsets (X, Y): [1:0-3-4,0-0-3]

Loading	(psf)	Spacing	2-0-0	CSI		DEFL	in	(loc)	l/defl	L/d	PLATES	GRIP
TCLL (roof)	20.0	Plate Grip DOL	1.15	TC	0.64	Vert(LL)	0.13	6-10	>873	240	MT20	244/190
TCDL	10.0	Lumber DOL	1.15	BC	0.35	Vert(CT)	-0.21	6-10	>529	180		
BCLL	0.0*	Rep Stress Incr	YES	WB	0.11	Horz(CT)	0.07	1	n/a	n/a		
BCDL	10.0	Code	IRC2015/TPI2014	Matrix-MS							Weight: 89 lb	FT = 20%

LUMBER

TOP CHORD 2x4 SP No.1
 BOT CHORD 2x4 SP No.1 *Except* B2:2x8 SP No.2
 WEBS 2x4 SP No.3 *Except* W3:2x6 SP No.2
 SLIDER Left 2x8 SP No.2 -- 2-6-0

BRACING

TOP CHORD Structural wood sheathing directly applied or 6-0-0 oc purlins, except end verticals.
 BOT CHORD Rigid ceiling directly applied or 10-0-0 oc bracing.
 WEBS 1 Row at midpt 4-5

REACTIONS (lb/size) 1=367/0-3-8, (min. 0-1-8), 5=367/0-3-8, (min. 0-1-8)

Max Horiz 1=304 (LC 10)
 Max Uplift 5=-140 (LC 8)
 Max Grav 1=477 (LC 17), 5=554 (LC 16)

FORCES (lb) - Max. Comp./Max. Ten. - All forces 250 (lb) or less except when shown.

TOP CHORD 2-12=-360/169, 3-12=-354/210, 3-4=-245/372, 5-7=-328/184, 4-7=-323/182
 BOT CHORD 1-13=-359/445, 6-13=-168/281, 5-6=-168/281
 WEBS 3-7=-381/217

NOTES

- Wind: ASCE 7-10; Vult=120mph (3-second gust) Vasd=95mph; TCDL=6.0psf; BCDL=6.0psf; h=30ft; B=20ft; L=20ft; eave=4ft; Cat. II; Exp B; Enclosed; MWFRS (directional) and C-C Exterior (2) 0-0-0 to 3-0-0, Interior (1) 3-0-0 to 9-2-4 zone; cantilever left and right exposed ; end vertical left and right exposed;C-C for members and forces & MWFRS for reactions shown; Lumber DOL=1.60 plate grip DOL=1.60
- * This truss has been designed for a live load of 20.0psf on the bottom chord in all areas where a rectangle 3-06-00 tall by 2-00-00 wide will fit between the bottom chord and any other members, with BCDL = 10.0psf.
- Provide mechanical connection (by others) of truss to bearing plate capable of withstanding 140 lb uplift at joint 5.
- This truss is designed in accordance with the 2015 International Residential Code sections R502.11.1 and R802.10.2 and referenced standard ANSI/TPI 1.

LOAD CASE(S) Standard

MiTek recommends that Stabilizers and required cross bracing be installed during truss erection, in accordance with Stabilizer Installation guide.

Job Q-2101667-1	Truss T7GRD	Truss Type Flat Girder	Qty 1	Ply 1	Brooklyn RH V2-Roof Job Reference (optional)
--------------------	----------------	---------------------------	----------	----------	---

Peak Truss Builders LLC, New Hill, user

Run: 8.43 S Feb 3 2021 Print: 8.430 S Feb 3 2021 MiTek Industries, Inc. Wed Jul 28 08:34:47

Page: 1

ID:jobWdk9loei4UXw0PYe6EytCC-1tZwKM?CyMOqJ2pQMkRC3JT0uhYzC5TmA8yleybyM

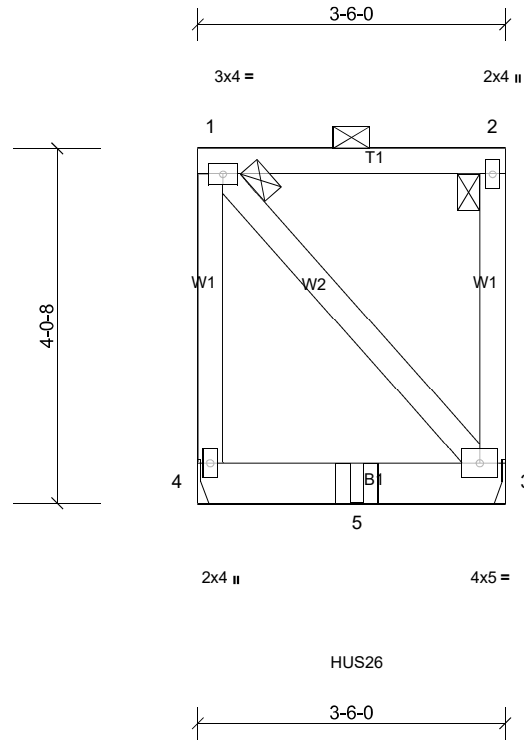

Scale = 1:26.2

Loading	(psf)	Spacing	2-0-0	CSI		DEFL	in	(loc)	l/defl	L/d	PLATES	GRIP
TCLL (roof)	20.0	Plate Grip DOL	1.15	TC	0.16	Vert(LL)	-0.02	3-4	>999	240	MT20	244/190
TCDL	10.0	Lumber DOL	1.15	BC	0.87	Vert(CT)	-0.05	3-4	>832	180		
BCLL	0.0*	Rep Stress Incr	NO	WB	0.03	Horz(CT)	0.00	3	n/a	n/a		
BCDL	10.0	Code	IRC2015/TPI2014	Matrix-MP							Weight: 30 lb	FT = 20%

LUMBER

TOP CHORD 2x4 SP No.1
 BOT CHORD 2x6 SP No.1
 WEBS 2x4 SP No.3

BRACING

TOP CHORD
 BOT CHORD

2-0-0 oc purlins: 1-2, except end verticals.

Rigid ceiling directly applied or 7-1-5 oc bracing.

MiTek recommends that Stabilizers and required cross bracing be installed during truss erection, in accordance with Stabilizer Installation guide.

REACTIONS (lb/size) 3=771/ Mechanical, (min. 0-1-8), 4=723/ Mechanical, (min. 0-1-8)

Max Horiz 4=-107 (LC 3)

Max Uplift 3=-165 (LC 4), 4=-158 (LC 3)

Max Grav 3=824 (LC 12), 4=774 (LC 13)

FORCES (lb) - Max. Comp./Max. Ten. - All forces 250 (lb) or less except when shown.

NOTES

- 1) Wind: ASCE 7-10; Vult=120mph (3-second gust) Vasd=95mph; TCDL=6.0psf; BCDL=6.0psf; h=30ft; B=20ft; L=20ft; eave=4ft; Cat. II; Exp B; Enclosed; MWFRS (directional); cantilever left and right exposed ; end vertical left and right exposed; Lumber DOL=1.60 plate grip DOL=1.60
- 2) Provide adequate drainage to prevent water ponding.
- 3) * This truss has been designed for a live load of 20.0psf on the bottom chord in all areas where a rectangle 3-06-00 tall by 2-00-00 wide will fit between the bottom chord and any other members.
- 4) Refer to girder(s) for truss to truss connections.
- 5) Provide mechanical connection (by others) of truss to bearing plate capable of withstanding 158 lb uplift at joint 4 and 165 lb uplift at joint 3.
- 6) This truss is designed in accordance with the 2015 International Residential Code sections R502.11.1 and R802.10.2 and referenced standard ANSI/TPI 1.
- 7) Graphical purlin representation does not depict the size or the orientation of the purlin along the top and/or bottom chord.
- 8) Use USP HUS26 (With 14-16d nails into Girder & 6-16d nails into Truss) or equivalent at 1-9-12 from the left end to connect truss(es) T5 (1 ply 2x4 SP) to back face of bottom chord.
- 9) Fill all nail holes where hanger is in contact with lumber.
- 10) In the LOAD CASE(S) section, loads applied to the face of the truss are noted as front (F) or back (B).

LOAD CASE(S) Standard

1) Dead + Roof Live (balanced): Lumber Increase=1.15, Plate Increase=1.15

Uniform Loads (lb/ft)

Vert: 1-2=-60, 3-4=-20

Concentrated Loads (lb)

Vert: 5=-1237 (B)

Job Q-2101667-1	Truss V1	Truss Type Valley	Qty 1	Ply 1	Brooklyn RH V2-Roof Job Reference (optional)
--------------------	-------------	----------------------	----------	----------	---

Peak Truss Builders LLC, New Hill, user

Run: 8.43 S Feb 3 2021 Print: 8.430 S Feb 3 2021 MiTek Industries, Inc. Wed Jul 28 08:34:47

Page: 1

ID:Whwu9pFSPrGHmtWJF_CLUzz7Ofr-1tZwKM?CyMOqJ2pQMkRC3JRjuazCwTmA8yleybyM

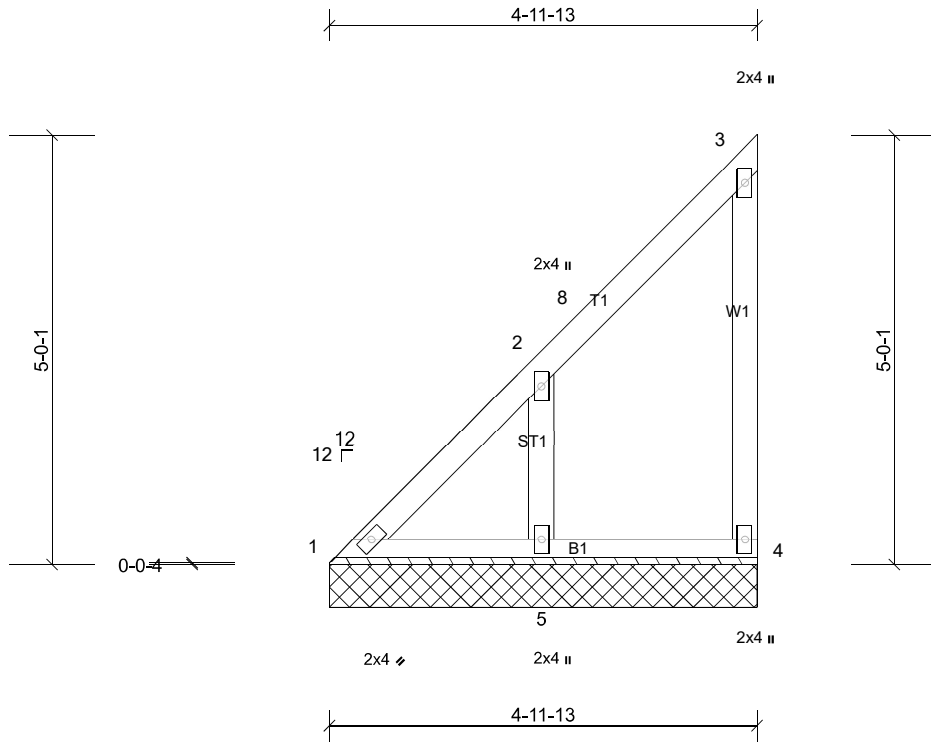

Scale = 1:26.9

Loading	(psf)	Spacing	2-0-0	CSI	DEFL	in	(loc)	l/defl	L/d	PLATES	GRIP	
TCLL (roof)	20.0	Plate Grip DOL	1.15	TC	0.31	Vert(LL)	n/a	-	n/a	999	MT20	244/190
TCDL	10.0	Lumber DOL	1.15	BC	0.04	Vert(TL)	n/a	-	n/a	999		
BCLL	0.0*	Rep Stress Incr	YES	WB	0.05	Horiz(TL)	0.00	4	n/a	n/a		
BCDL	10.0	Code	IRC2015/TPI2014	Matrix-MP							Weight: 27 lb	FT = 20%

LUMBER

TOP CHORD 2x4 SP No.1
 BOT CHORD 2x4 SP No.1
 WEBS 2x4 SP No.3
 OTHERS 2x4 SP No.3

BRACING

TOP CHORD Structural wood sheathing directly applied or 4-11-13 oc purlins, except end verticals.
 BOT CHORD Rigid ceiling directly applied or 10-0-0 oc bracing.

REACTIONS (lb/size) 1=76/4-11-13, (min. 0-1-8), 4=71/4-11-13, (min. 0-1-8), 5=241/4-11-13, (min. 0-1-8)
 Max Horiz 1=144 (LC 8)
 Max Uplift 1=-5 (LC 9), 4=-42 (LC 8), 5=-114 (LC 11)
 Max Grav 1=120 (LC 17), 4=89 (LC 16), 5=258 (LC 16)

MiTek recommends that Stabilizers and required cross bracing be installed during truss erection, in accordance with Stabilizer Installation guide.

FORCES (lb) - Max. Comp./Max. Ten. - All forces 250 (lb) or less except when shown.
 TOP CHORD 1-2=-253/240

NOTES

- 1) Wind: ASCE 7-10; Vult=120mph (3-second gust) Vasd=95mph; TCDL=6.0psf; BCDL=6.0psf; h=30ft; B=20ft; L=20ft; eave=4ft; Cat. II; Exp B; Enclosed; MWFRS (directional) and C-C Exterior (2) 0-0-4 to 3-0-4, Interior (1) 3-0-4 to 4-10-5 zone; cantilever left and right exposed ; end vertical left and right exposed;C-C for members and forces & MWFRS for reactions shown; Lumber DOL=1.60 plate grip DOL=1.60
- 2) Gable requires continuous bottom chord bearing.
- 3) * This truss has been designed for a live load of 20.0psf on the bottom chord in all areas where a rectangle 3-06-00 tall by 2-00-00 wide will fit between the bottom chord and any other members.
- 4) Provide mechanical connection (by others) of truss to bearing plate capable of withstanding 42 lb uplift at joint 4, 5 lb uplift at joint 1 and 114 lb uplift at joint 5.
- 5) This truss is designed in accordance with the 2015 International Residential Code sections R502.11.1 and R802.10.2 and referenced standard ANSI/TPI 1.

LOAD CASE(S) Standard

Job Q-2101667-1	Truss V2	Truss Type Valley	Qty 1	Ply 1	Brooklyn RH V2-Roof Job Reference (optional)
--------------------	-------------	----------------------	----------	----------	---

Peak Truss Builders LLC, New Hill, user

Run: 8.43 S Feb 3 2021 Print: 8.430 S Feb 3 2021 MiTek Industries, Inc. Wed Jul 28 08:34:48

Page: 1

ID:Whwu9pFSPrGHmtWJF_CLUzz7Ofr-V37JXh0rjfWhLTd?z4FglHrfHIE6ifQd?quWH5ytbyL

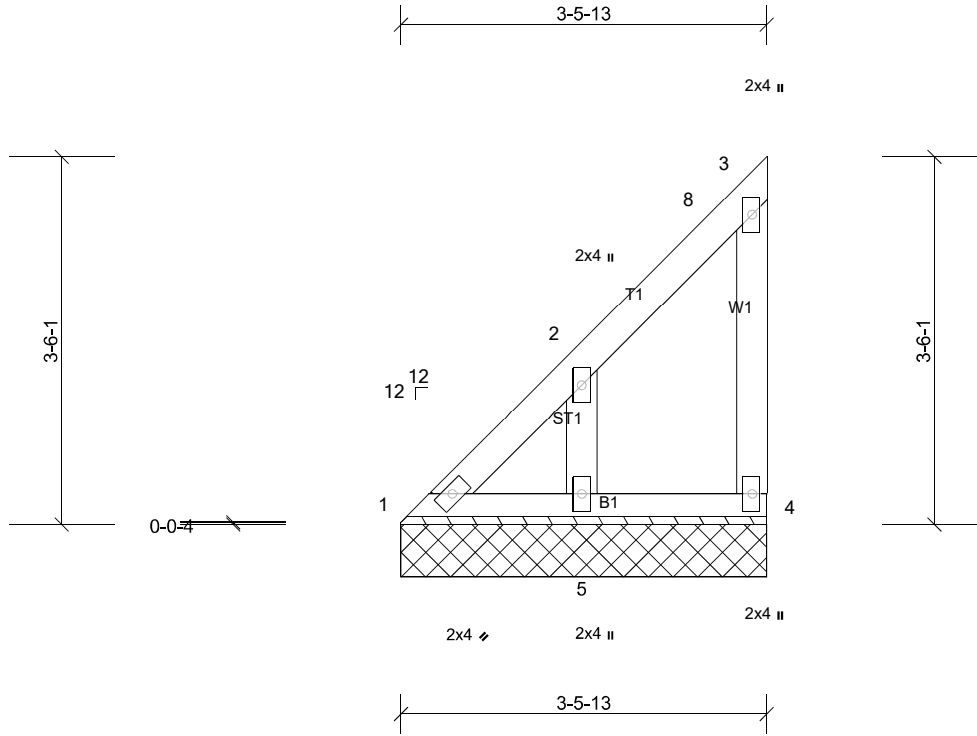

Scale = 1:22

Loading	(psf)	Spacing	2-0-0	CSI	DEFL	in	(loc)	I/defl	L/d	PLATES	GRIP	
TCLL (roof)	20.0	Plate Grip DOL	1.15	TC	0.13	Vert(LL)	n/a	-	n/a	999	MT20	244/190
TCDL	10.0	Lumber DOL	1.15	BC	0.02	Vert(TL)	n/a	-	n/a	999		
BCLL	0.0*	Rep Stress Incr	YES	WB	0.03	Horiz(TL)	0.00	4	n/a	n/a		
BCDL	10.0	Code	IRC2015/TPI2014	Matrix-MP							Weight: 18 lb	FT = 20%

LUMBER

TOP CHORD 2x4 SP No.1
 BOT CHORD 2x4 SP No.1
 WEBS 2x4 SP No.3
 OTHERS 2x4 SP No.3

BRACING

TOP CHORD Structural wood sheathing directly applied or 3-5-13 oc purlins, except end verticals.
 BOT CHORD Rigid ceiling directly applied or 10-0-0 oc bracing.

REACTIONS (lb/size) 1=54/3-5-13, (min. 0-1-8), 4=48/3-5-13, (min. 0-1-8), 5=165/3-5-13, (min. 0-1-8)
 Max Horiz 1=97 (LC 8)
 Max Uplift 1=-1 (LC 9), 4=-29 (LC 8), 5=-73 (LC 11)
 Max Grav 1=82 (LC 17), 4=61 (LC 16), 5=175 (LC 16)

MiTek recommends that Stabilizers and required cross bracing be installed during truss erection, in accordance with Stabilizer Installation guide.

FORCES (lb) - Max. Comp./Max. Ten. - All forces 250 (lb) or less except when shown.

NOTES

- 1) Wind: ASCE 7-10; Vult=120mph (3-second gust) Vasd=95mph; TCDL=6.0psf; BCDL=6.0psf; h=30ft; B=20ft; L=20ft; eave=4ft; Cat. II; Exp B; Enclosed; MWFRS (directional) and C-C Exterior (2) 0-0-4 to 3-0-4, Interior (1) 3-0-4 to 3-4-5 zone; cantilever left and right exposed; end vertical left and right exposed; C-C for members and forces & MWFRS for reactions shown; Lumber DOL=1.60 plate grip DOL=1.60
- 2) Gable requires continuous bottom chord bearing.
- 3) * This truss has been designed for a live load of 20.0psf on the bottom chord in all areas where a rectangle 3-06-00 tall by 2-00-00 wide will fit between the bottom chord and any other members.
- 4) Provide mechanical connection (by others) of truss to bearing plate capable of withstanding 29 lb uplift at joint 4, 1 lb uplift at joint 1 and 73 lb uplift at joint 5.
- 5) This truss is designed in accordance with the 2015 International Residential Code sections R502.11.1 and R802.10.2 and referenced standard ANSI/TPI 1.

LOAD CASE(S) Standard

Job Q-2101667-1	Truss V3	Truss Type Valley	Qty 1	Ply 1	Brooklyn RH V2-Roof Job Reference (optional)
--------------------	-------------	----------------------	----------	----------	---

Peak Truss Builders LLC, New Hill, user

Run: 8.43 S Feb 3 2021 Print: 8.430 S Feb 3 2021 MiTek Industries, Inc. Wed Jul 28 08:34:48

Page: 1

ID:Whwu9pFSPrGHmtWjF_CLUzz7Ofr-V37JXh0rjWWhLTd?z4FglHrgnlEsfid?quWH5ytbyL

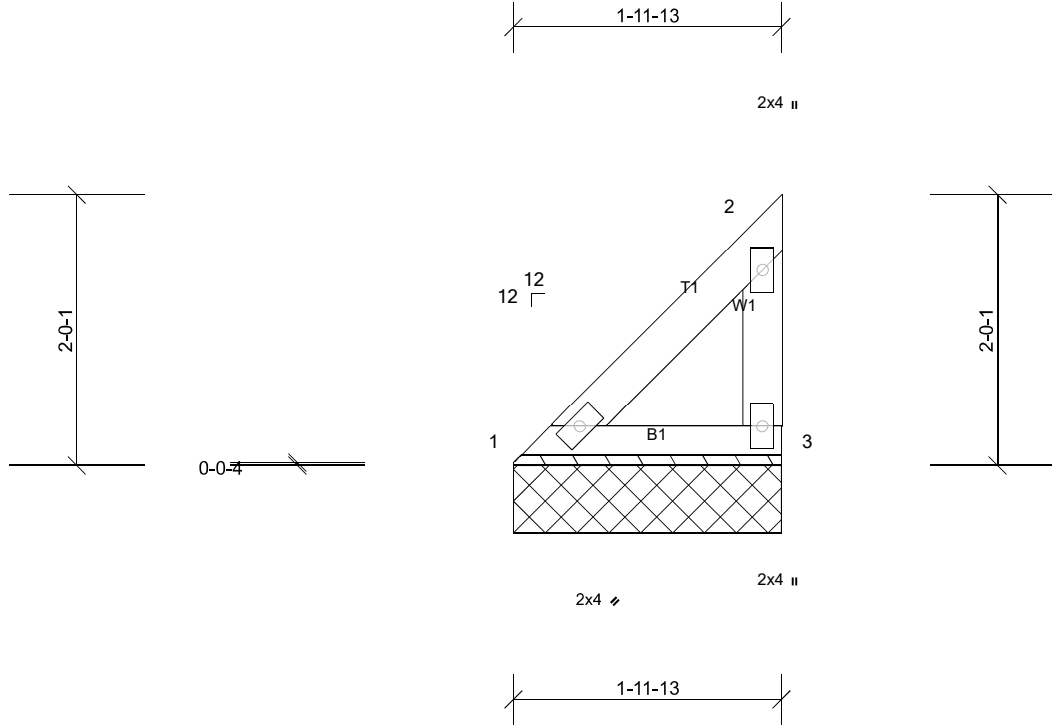

Scale = 1:17.1

Loading	(psf)	Spacing	2-0-0	CSI		DEFL	in	(loc)	I/defl	L/d	PLATES	GRIP
TCLL (roof)	20.0	Plate Grip DOL	1.15	TC	0.03	Vert(LL)	n/a	-	n/a	999	MT20	244/190
TCDL	10.0	Lumber DOL	1.15	BC	0.04	Vert(TL)	n/a	-	n/a	999		
BCLL	0.0*	Rep Stress Incr	YES	WB	0.00	Horiz(TL)	0.00	3	n/a	n/a		
BCDL	10.0	Code	IRC2015/TPI2014	Matrix-MP							Weight: 8 lb	FT = 20%

LUMBER

TOP CHORD 2x4 SP No.1
 BOT CHORD 2x4 SP No.1
 WEBS 2x4 SP No.3

BRACING

TOP CHORD Structural wood sheathing directly applied or 1-11-13 oc purlins, except end verticals.
 BOT CHORD Rigid ceiling directly applied or 10-0-0 oc bracing.

REACTIONS (lb/size) 1=74/1-11-13, (min. 0-1-8), 3=74/1-11-13, (min. 0-1-8)
 Max Horiz 1=50 (LC 8)
 Max Uplift 3=-19 (LC 11)
 Max Grav 1=76 (LC 17), 3=82 (LC 16)

MiTek recommends that Stabilizers and required cross bracing be installed during truss erection, in accordance with Stabilizer Installation guide.

FORCES (lb) - Max. Comp./Max. Ten. - All forces 250 (lb) or less except when shown.

NOTES

- 1) Wind: ASCE 7-10; Vult=120mph (3-second gust) Vasd=95mph; TCDL=6.0psf; BCDL=6.0psf; h=30ft; B=20ft; L=20ft; eave=4ft; Cat. II; Exp B; Enclosed; MWFRS (directional) and C-C Exterior (2) zone; cantilever left and right exposed; end vertical left and right exposed; C-C for members and forces & MWFRS for reactions shown; Lumber DOL=1.60 plate grip DOL=1.60
- 2) Gable requires continuous bottom chord bearing.
- 3) * This truss has been designed for a live load of 20.0psf on the bottom chord in all areas where a rectangle 3-06-00 tall by 2-00-00 wide will fit between the bottom chord and any other members.
- 4) Provide mechanical connection (by others) of truss to bearing plate capable of withstanding 19 lb uplift at joint 3.
- 5) This truss is designed in accordance with the 2015 International Residential Code sections R502.11.1 and R802.10.2 and referenced standard ANSI/TPI 1.

LOAD CASE(S) Standard

Job Q-2101667-1	Truss V5	Truss Type Valley	Qty 1	Ply 1	Brooklyn RH V2-Roof Job Reference (optional)
--------------------	-------------	----------------------	----------	----------	---

Peak Truss Builders LLC, New Hill, user

Run: 8.43 S Feb 3 2021 Print: 8.430 S Feb 3 2021 MiTek Industries, Inc. Wed Jul 28 08:34:49

Page: 1

ID:Whwu9pFSPrGHmtWJF_CLUzz7Ofr-zGhhl11TUzeYzdCBXnmvIUOf6hXeR5tmEUd3pXybyK

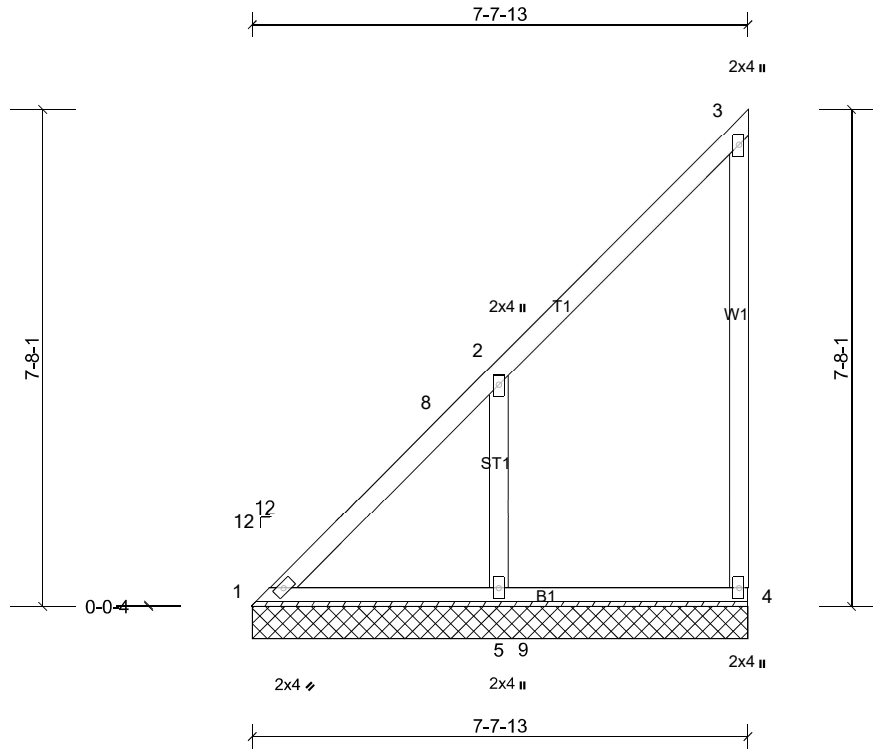

Scale = 1:35.6

Loading	(psf)	Spacing	2-0-0	CSI	DEFL	in	(loc)	l/defl	L/d	PLATES	GRIP	
TCLL (roof)	20.0	Plate Grip DOL	1.15	TC	0.82	Vert(LL)	n/a	-	n/a	999	MT20	244/190
TCDL	10.0	Lumber DOL	1.15	BC	0.13	Vert(TL)	n/a	-	n/a	999		
BCLL	0.0*	Rep Stress Incr	YES	WB	0.08	Horiz(TL)	0.00	4	n/a	n/a		
BCDL	10.0	Code	IRC2015/TPI2014	Matrix-MP							Weight: 42 lb	FT = 20%

LUMBER

TOP CHORD 2x4 SP No.1
 BOT CHORD 2x4 SP No.1
 WEBS 2x4 SP No.3
 OTHERS 2x4 SP No.3

BRACING

TOP CHORD Structural wood sheathing directly applied or 6-0-0 oc purlins, except end verticals.
 BOT CHORD Rigid ceiling directly applied or 10-0-0 oc bracing.

REACTIONS (lb/size) 1=116/7-7-13, (min. 0-1-8), 4=110/7-7-13, (min. 0-1-8),
 5=375/7-7-13, (min. 0-1-8)
 Max Horiz 1=228 (LC 8)
 Max Uplift 1=-13 (LC 9), 4=-66 (LC 8), 5=-187 (LC 11)
 Max Grav 1=182 (LC 17), 4=187 (LC 16), 5=461 (LC 16)

MiTek recommends that Stabilizers and required cross bracing be installed during truss erection, in accordance with Stabilizer Installation guide.

FORCES (lb) - Max. Comp./Max. Ten. - All forces 250 (lb) or less except when shown.
 TOP CHORD 1-8=-381/340, 2-8=-357/369
 WEBS 2-5=-324/229

NOTES

- 1) Wind: ASCE 7-10; Vult=120mph (3-second gust) Vasd=95mph; TC DL=6.0psf; BC DL=6.0psf; h=30ft; B=20ft; L=20ft; eave=4ft; Cat. II; Exp B; Enclosed; MWFRS (directional) and C-C Exterior (2) 0-0-4 to 3-0-4, Interior (1) 3-0-4 to 7-6-5 zone; cantilever left and right exposed ; end vertical left and right exposed; C-C for members and forces & MWFRS for reactions shown; Lumber DOL=1.60 plate grip DOL=1.60
- 2) Gable requires continuous bottom chord bearing.
- 3) * This truss has been designed for a live load of 20.0psf on the bottom chord in all areas where a rectangle 3-06-00 tall by 2-00-00 wide will fit between the bottom chord and any other members, with BC DL = 10.0psf.
- 4) Provide mechanical connection (by others) of truss to bearing plate capable of withstanding 66 lb uplift at joint 4, 13 lb uplift at joint 1 and 187 lb uplift at joint 5.
- 5) This truss is designed in accordance with the 2015 International Residential Code sections R502.11.1 and R802.10.2 and referenced standard ANSI/TPI 1.

LOAD CASE(S) Standard

Job Q-2101667-1	Truss V6	Truss Type Valley	Qty 1	Ply 1	Brooklyn RH V2-Roof Job Reference (optional)
--------------------	-------------	----------------------	----------	----------	---

Peak Truss Builders LLC, New Hill, user

Run: 8.43 S Feb 3 2021 Print: 8.430 S Feb 3 2021 MiTek Industries, Inc. Wed Jul 28 08:34:49

Page: 1

ID: _tUGN9G599O8O15vohja0Az7Ofq-zGhhl11TUzeYzdCBXnmvIUOk8hZiR6GmEUd3pXybyK

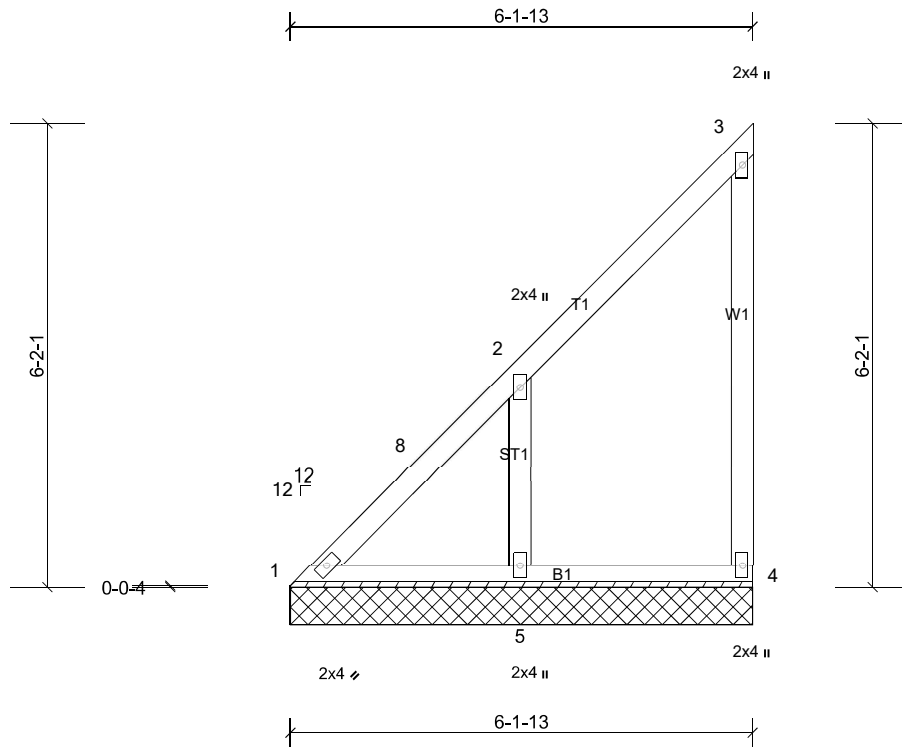

Scale = 1:30.7

Loading	(psf)	Spacing	2-0-0	CSI	DEFL	in	(loc)	l/defl	L/d	PLATES	GRIP	
TCLL (roof)	20.0	Plate Grip DOL	1.15	TC	0.50	Vert(LL)	n/a	-	n/a	999	MT20	244/190
TCDL	10.0	Lumber DOL	1.15	BC	0.06	Vert(TL)	n/a	-	n/a	999		
BCLL	0.0*	Rep Stress Incr	YES	WB	0.06	Horiz(TL)	0.00	4	n/a	n/a		
BCDL	10.0	Code	IRC2015/TPI2014	Matrix-MP							Weight: 33 lb	FT = 20%

LUMBER

TOP CHORD 2x4 SP No.1
 BOT CHORD 2x4 SP No.1
 WEBS 2x4 SP No.3
 OTHERS 2x4 SP No.3

BRACING

TOP CHORD Structural wood sheathing directly applied or 6-0-0 oc purlins, except end verticals.
 BOT CHORD Rigid ceiling directly applied or 10-0-0 oc bracing.

REACTIONS (lb/size) 1=93/6-1-13, (min. 0-1-8), 4=88/6-1-13, (min. 0-1-8), 5=299/6-1-13, (min. 0-1-8)
 Max Horiz 1=181 (LC 8)
 Max Uplift 1=-9 (LC 9), 4=-53 (LC 8), 5=-146 (LC 11)
 Max Grav 1=150 (LC 17), 4=110 (LC 16), 5=321 (LC 16)

MiTek recommends that Stabilizers and required cross bracing be installed during truss erection, in accordance with Stabilizer Installation guide.

FORCES (lb) - Max. Comp./Max. Ten. - All forces 250 (lb) or less except when shown.
 TOP CHORD 1-8=-313/276, 2-8=-295/299
 WEBS 2-5=-259/188

NOTES

- 1) Wind: ASCE 7-10; Vult=120mph (3-second gust) Vasd=95mph; TCDL=6.0psf; BCDL=6.0psf; h=30ft; B=20ft; L=20ft; eave=4ft; Cat. II; Exp B; Enclosed; MWFRS (directional) and C-C Exterior (2) 0-0-4 to 3-0-15, Interior (1) 3-0-15 to 6-0-5 zone; cantilever left and right exposed ; end vertical left and right exposed;C-C for members and forces & MWFRS for reactions shown; Lumber DOL=1.60 plate grip DOL=1.60
- 2) Gable requires continuous bottom chord bearing.
- 3) * This truss has been designed for a live load of 20.0psf on the bottom chord in all areas where a rectangle 3-06-00 tall by 2-00-00 wide will fit between the bottom chord and any other members.
- 4) Provide mechanical connection (by others) of truss to bearing plate capable of withstanding 53 lb uplift at joint 4, 9 lb uplift at joint 1 and 146 lb uplift at joint 5.
- 5) This truss is designed in accordance with the 2015 International Residential Code sections R502.11.1 and R802.10.2 and referenced standard ANSI/TPI 1.

LOAD CASE(S) Standard

Job Q-2101667-1	Truss V7	Truss Type Valley	Qty 1	Ply 1	Brooklyn RH V2-Roof Job Reference (optional)
--------------------	-------------	----------------------	----------	----------	---

Peak Truss Builders LLC, New Hill, user

Run: 8.43 S Feb 3 2021 Print: 8.430 S Feb 3 2021 MiTek Industries, Inc. Wed Jul 28 08:34:49

Page: 1

ID: _UGN9G599O8O15vohja0Az7Ofq-zGhh11TUzeyZdCBXnmvIUOnyhZ6R6TmEUd3pXybyK

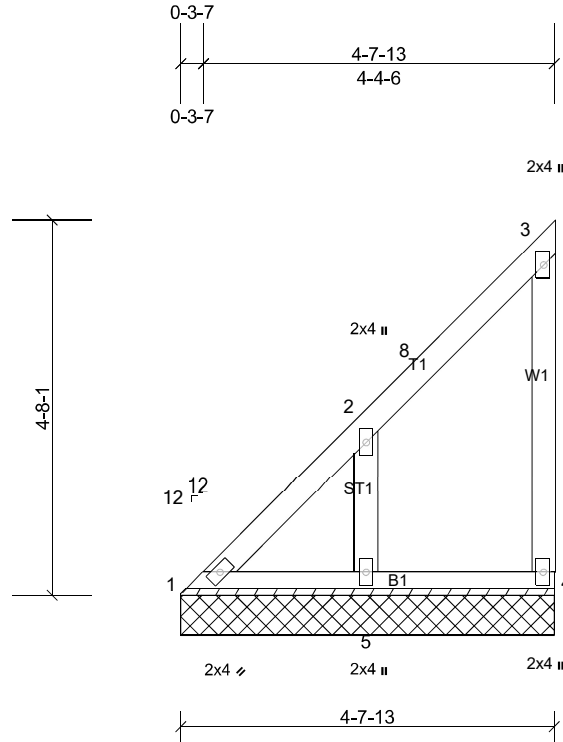

Scale = 1:28.7

Loading	(psf)	Spacing	2-0-0	CSI	DEFL	in	(loc)	l/defl	L/d	PLATES	GRIP	
TCLL (roof)	20.0	Plate Grip DOL	1.15	TC	0.26	Vert(LL)	n/a	-	n/a	999	MT20	244/190
TCDL	10.0	Lumber DOL	1.15	BC	0.03	Vert(TL)	n/a	-	n/a	999		
BCLL	0.0*	Rep Stress Incr	YES	WB	0.04	Horiz(TL)	0.00	4	n/a	n/a		
BCDL	10.0	Code	IRC2015/TPI2014	Matrix-MP							Weight: 25 lb	FT = 20%

LUMBER

TOP CHORD 2x4 SP No.1
 BOT CHORD 2x4 SP No.1
 WEBS 2x4 SP No.3
 OTHERS 2x4 SP No.3

BRACING

TOP CHORD Structural wood sheathing directly applied or 4-7-13 oc purlins, except end verticals.
 BOT CHORD Rigid ceiling directly applied or 10-0-0 oc bracing.

REACTIONS (lb/size) 1=71/4-7-13, (min. 0-1-8), 4=66/4-7-13, (min. 0-1-8), 5=224/4-7-13, (min. 0-1-8)
 Max Horiz 1=133 (LC 8)
 Max Uplift 1=-4 (LC 9), 4=-39 (LC 8), 5=-105 (LC 11)
 Max Grav 1=112 (LC 17), 4=82 (LC 16), 5=239 (LC 16)

MiTek recommends that Stabilizers and required cross bracing be installed during truss erection, in accordance with Stabilizer Installation guide.

FORCES (lb) - Max. Comp./Max. Ten. - All forces 250 (lb) or less except when shown.

NOTES

- 1) Wind: ASCE 7-10; Vult=120mph (3-second gust) Vasd=95mph; TCDL=6.0psf; BCDL=6.0psf; h=30ft; B=20ft; L=20ft; eave=4ft; Cat. II; Exp B; Enclosed; MWFRS (directional) and C-C Exterior (2) 0-0-4 to 3-0-4, Interior (1) 3-0-4 to 4-6-5 zone; cantilever left and right exposed; end vertical left and right exposed; C-C for members and forces & MWFRS for reactions shown; Lumber DOL=1.60 plate grip DOL=1.60
- 2) Gable requires continuous bottom chord bearing.
- 3) * This truss has been designed for a live load of 20.0psf on the bottom chord in all areas where a rectangle 3-06-00 tall by 2-00-00 wide will fit between the bottom chord and any other members.
- 4) Provide mechanical connection (by others) of truss to bearing plate capable of withstanding 39 lb uplift at joint 4, 4 lb uplift at joint 1 and 105 lb uplift at joint 5.
- 5) This truss is designed in accordance with the 2015 International Residential Code sections R502.11.1 and R802.10.2 and referenced standard ANSI/TPI 1.

LOAD CASE(S) Standard

Job Q-2101667-1	Truss V8	Truss Type Valley	Qty 1	Ply 1	Brooklyn RH V2-Roof Job Reference (optional)
--------------------	-------------	----------------------	----------	----------	---

Peak Truss Builders LLC, New Hill, user

Run: 8.43 S Feb 3 2021 Print: 8.430 S Feb 3 2021 MiTek Industries, Inc. Wed Jul 28 08:34:50

Page: 1

ID: tUGN9G599O8O15vohja0Az7Ofq-RSF3yN25FHmOannO5VH8qix?D5vdAZ_ws8NcLzytbyJ

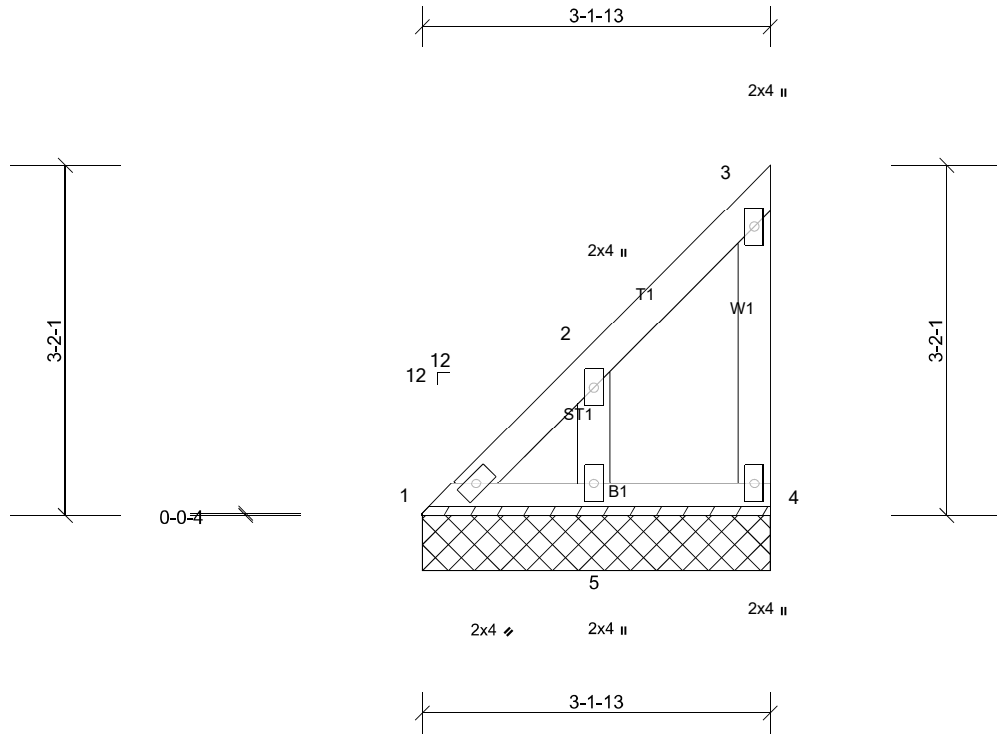

Scale = 1:20.9

Loading	(psf)	Spacing	2-0-0	CSI	DEFL	in	(loc)	I/defl	L/d	PLATES	GRIP	
TCLL (roof)	20.0	Plate Grip DOL	1.15	TC	0.10	Vert(LL)	n/a	-	n/a	999	MT20	244/190
TCDL	10.0	Lumber DOL	1.15	BC	0.02	Vert(TL)	n/a	-	n/a	999		
BCLL	0.0*	Rep Stress Incr	YES	WB	0.03	Horiz(TL)	0.00	4	n/a	n/a		
BCDL	10.0	Code	IRC2015/TPI2014	Matrix-MP							Weight: 16 lb	FT = 20%

LUMBER

TOP CHORD 2x4 SP No.1
 BOT CHORD 2x4 SP No.1
 WEBS 2x4 SP No.3
 OTHERS 2x4 SP No.3

BRACING

TOP CHORD Structural wood sheathing directly applied or 3-1-13 oc purlins, except end verticals.
 BOT CHORD Rigid ceiling directly applied or 10-0-0 oc bracing.

REACTIONS (lb/size) 1=49/3-1-13, (min. 0-1-8), 4=43/3-1-13, (min. 0-1-8), 5=148/3-1-13, (min. 0-1-8)
 Max Horiz 1=86 (LC 8)
 Max Uplift 4=-26 (LC 8), 5=64 (LC 11)
 Max Grav 1=74 (LC 17), 4=55 (LC 16), 5=157 (LC 16)

MiTek recommends that Stabilizers and required cross bracing be installed during truss erection, in accordance with Stabilizer Installation guide.

FORCES (lb) - Max. Comp./Max. Ten. - All forces 250 (lb) or less except when shown.

NOTES

- 1) Wind: ASCE 7-10; Vult=120mph (3-second gust) Vasd=95mph; TC DL=6.0psf; BC DL=6.0psf; h=30ft; B=20ft; L=20ft; eave=4ft; Cat. II; Exp B; Enclosed; MWFRS (directional) and C-C Exterior (2) zone; cantilever left and right exposed; end vertical left and right exposed; C-C for members and forces & MWFRS for reactions shown; Lumber DOL=1.60 plate grip DOL=1.60
- 2) Gable requires continuous bottom chord bearing.
- 3) * This truss has been designed for a live load of 20.0psf on the bottom chord in all areas where a rectangle 3-06-00 tall by 2-00-00 wide will fit between the bottom chord and any other members.
- 4) Provide mechanical connection (by others) of truss to bearing plate capable of withstanding 26 lb uplift at joint 4 and 64 lb uplift at joint 5.
- 5) This truss is designed in accordance with the 2015 International Residential Code sections R502.11.1 and R802.10.2 and referenced standard ANSI/TPI 1.

LOAD CASE(S) Standard

Job Q-2101667-1	Truss V9	Truss Type Valley	Qty 1	Ply 1	Brooklyn RH V2-Roof Job Reference (optional)
--------------------	-------------	----------------------	----------	----------	---

Peak Truss Builders LLC, New Hill, user

Run: 8.43 S Feb 3 2021 Print: 8.430 S Feb 3 2021 MiTek Industries, Inc. Wed Jul 28 08:34:50

Page: 1

ID: _tUGN9G599O8O15vohja0Az7Ofq-RSF3yN25FHmOannO5VH8qix0Q5vVAZNws8NcLzytbyJ

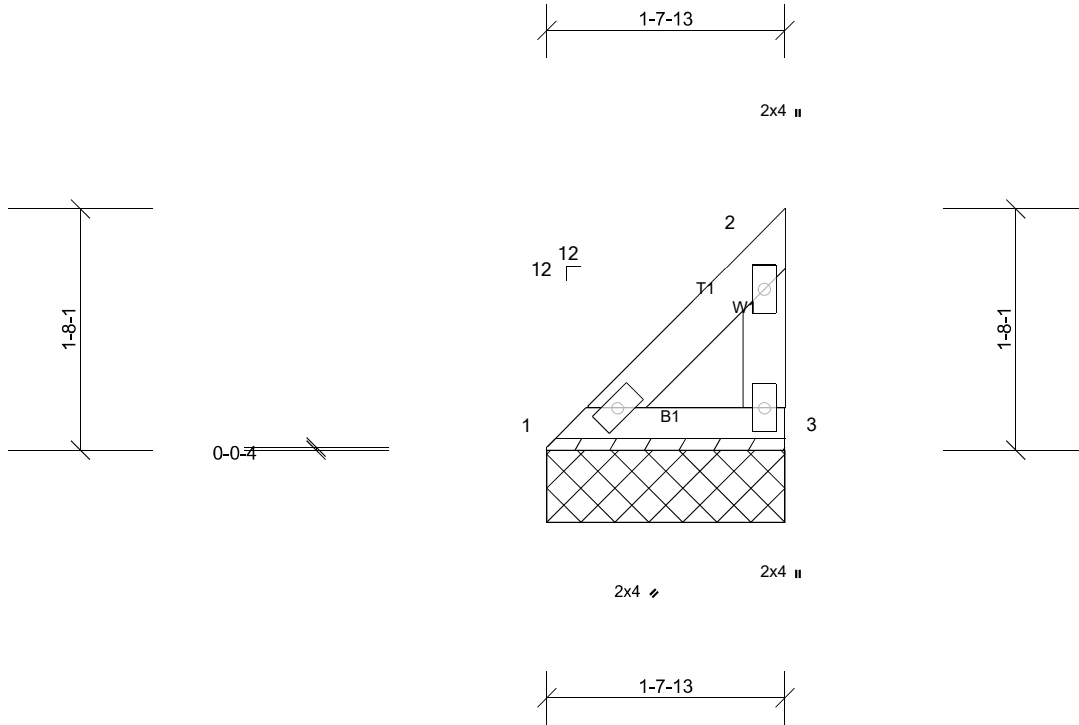

Scale = 1:16

Loading	(psf)	Spacing	2-0-0	CSI	DEFL	in	(loc)	I/defl	L/d	PLATES	GRIP	
TCLL (roof)	20.0	Plate Grip DOL	1.15	TC	0.02	Vert(LL)	n/a	-	n/a	999	MT20	244/190
TCDL	10.0	Lumber DOL	1.15	BC	0.02	Vert(TL)	n/a	-	n/a	999		
BCLL	0.0*	Rep Stress Incr	YES	WB	0.00	Horiz(TL)	0.00	3	n/a	n/a		
BCDL	10.0	Code	IRC2015/TPI2014	Matrix-MP							Weight: 7 lb	FT = 20%

LUMBER

TOP CHORD 2x4 SP No.1
 BOT CHORD 2x4 SP No.1
 WEBS 2x4 SP No.3

BRACING

TOP CHORD Structural wood sheathing directly applied or 1-7-13 oc purlins, except end verticals.
 BOT CHORD Rigid ceiling directly applied or 10-0-0 oc bracing.

REACTIONS (lb/size) 1=60/1-7-13, (min. 0-1-8), 3=60/1-7-13, (min. 0-1-8)
 Max Horiz 1=39 (LC 8)
 Max Uplift 3=-15 (LC 11)
 Max Grav 1=61 (LC 17), 3=67 (LC 16)

MiTek recommends that Stabilizers and required cross bracing be installed during truss erection, in accordance with Stabilizer Installation guide.

FORCES (lb) - Max. Comp./Max. Ten. - All forces 250 (lb) or less except when shown.

NOTES

- 1) Wind: ASCE 7-10; Vult=120mph (3-second gust) Vasd=95mph; TCDL=6.0psf; BCDL=6.0psf; h=30ft; B=20ft; L=20ft; eave=4ft; Cat. II; Exp B; Enclosed; MWFRS (directional) and C-C Exterior (2) zone; cantilever left and right exposed; end vertical left and right exposed; C-C for members and forces & MWFRS for reactions shown; Lumber DOL=1.60 plate grip DOL=1.60
- 2) Gable requires continuous bottom chord bearing.
- 3) * This truss has been designed for a live load of 20.0psf on the bottom chord in all areas where a rectangle 3-06-00 tall by 2-00-00 wide will fit between the bottom chord and any other members.
- 4) Provide mechanical connection (by others) of truss to bearing plate capable of withstanding 15 lb uplift at joint 3.
- 5) This truss is designed in accordance with the 2015 International Residential Code sections R502.11.1 and R802.10.2 and referenced standard ANSI/TPI 1.

LOAD CASE(S) Standard