



NC DEPARTMENT OF
**HEALTH AND
HUMAN SERVICES**

ROY COOPER • Governor
MANDY COHEN, MD, MPH • Secretary
MARK T. BENTON • Assistant Secretary for Public Health
Division of Public Health

COMMON FORM FOR LICENSED SOIL SCIENTIST COVID-19 PERMIT OPTION FOR NON-ENGINEERED SYSTEMS
See Instructions for Use in Appendix A

Except for "Date received", this Section to be completed by the LSS in accordance with S.L. 2020-97, Section 3.19 and G.S. 130A-336.2

LHD USE ONLY: Initial submittal of this NOI received: 08-23-21 by MTO
Date Initials

PART 1: Notice of Intent to Construct (NOI)

- New Expansion
 Repair – LHD Permit Number _____ Repair – EOP/LSS Permit Number _____

1. Facility Owner's name: (Owner, Company Name, Utility, Partnership, Individual, etc.): _____

Deane Manning Realty Profit Sharing Plan LLC

Mailing address: 2200 Premier Resort Blvd Unit B Ste 18 City: N Myrtle Beach State: SC Zip: 29582-9209

Telephone number: _____ E-mail Address: lec.harnett.newhomes@gmail.com

2. Licensed Soil Scientist (LSS) name: Thomas L. Boyce LSS License number: 1241

Mailing address: PO Box 81 City: Pittsboro State: NC Zip: 27312

Telephone number: 919-868-8135 E-mail Address: nc1ss1241@gmail.com

3. Licensed Geologist (LG) (if applicable) name: _____ License Number: _____

Mailing address: _____ City: _____ State: _____ Zip: _____

Telephone number: _____ E-mail Address: _____

4. Proof of Errors and Omissions or other appropriate liability insurance for the following persons is attached that includes the name of the insurer, name of the insured and the effective dates of coverage:

- LSS LG

5. Property location (physical address, tax parcel identification number or subdivision lot, block number of the property to be permitted): Carolina Seasons lot 62

County Name: Harnett

6. Type of facility: Place of residence No. Bedrooms: 3 No. Occupants: 6 max
 Place of business Basis for flow calculation: _____
 Place of public assembly Basis for flow calculation: _____

NC DEPARTMENT OF HEALTH AND HUMAN SERVICES • DIVISION OF PUBLIC HEALTH

LOCATION: 5605 Six Forks Road, Raleigh, NC 27609

MAILING ADDRESS: 1642 Mail Service Center, Raleigh, NC 27699-1642

www.ncdhhs.gov • TEL: 919-707-5854 • FAX: 919-845-3972

AN EQUAL OPPORTUNITY / AFFIRMATIVE ACTION EMPLOYER

- 7. Factors that would affect the wastewater load: none
- 8. Type, location, and classification (per Rule .1961) of wastewater system: yes
- 9. Design wastewater flow: 340 gpd
 Design wastewater strength: domestic high strength industrial process *(For industrial process wastewater, a Professional Engineer licensed in accordance with G.S. 89C shall design the on-site wastewater system.)*
- 10. A plat as defined in G.S. 130A-334(7a) is attached: Yes No
 A site plan as defined in G.S. 130A-334(13a) is attached: Yes No
In accordance with G.S. 130A-335(f), an LSS COVID-19 Permit with a plat is valid without expiration and an LSS COVID-19 Permit with a site plan is valid for five years.
- 11. Owner meets requirements of ownership or control of the system per 15A NCAC 18A .1938(j): Yes No
- 12. Easement, right of way or encroachment agreement required per 15A NCAC 18A .1938(j): Yes No
 If yes, documentation filed in _____ County Register of Deeds in Deed book _____ Page _____
- 13. Multi-party agreements required, as applicable, pursuant to 15A NCAC 18A .1937(h): Yes No
 If yes, agreements filed in _____ County Register of Deeds in Deed book _____ Page _____
- 14. Location of proposed or existing wells (drinking water, irrigation, geothermal, groundwater monitoring, sampling, etc.) and any potable and non-potable water conveyance lines is indicated on attached plans and complies with 15A NCAC 18A .1950: Yes No
 This is a saprolite system. Yes No
- 15. Evaluation(s) of soil conditions and site features in accordance with G.S. 130A-335(a1) signed and sealed by a LSS is attached: Yes No
- 16. Evaluation of geologic and hydrogeologic conditions signed and sealed by a LG is attached Yes NA
- 17. Proposed landscape, site, drainage, or soil modifications are attached: Yes NA

Attestation by LSS pursuant to S.L. 2020-97, Section 3.19 and G.S. 130A-336.2

I, Thomas J. Boyce hereby attest that the information required to be included with this Notice of Intent to Construct is accurate and complete to the best of my knowledge and that the proposed system shall meet applicable federal, State, and local laws, regulations, rules and ordinances, and that the proposed system does not require a Professional Engineer, licensed in accordance with G.S. 89C, and in accordance with 15A NCAC 18A .1938 and activities determined to be engineering as determined by the North Carolina Board of Examiners for Engineers and Surveyors."

Thomas J. Boyce
Signature of Licensed Soil Scientist

7-8-21
Date



NOTES:

LIABILITY: *The Department, the Department's authorized agents, or local health departments shall have no liability for wastewater systems designed, constructed, and installed pursuant to an LSS COVID-19 Permit Option [S.L. 2020-97, Section 3.19(d) and G.S. 130A-336.2]*

RIGHT OF ENTRY: *The submittal of this **Notice of Intent to Construct** grants right of entry to the Local Health Department and the State to the referenced property.*

ISSUANCE OF BUILDING PERMIT: *Once the LHD deems that the Notice of Intent to Construct is complete via signature in the section below, the owner may apply to the local permitting agency for a permit for electrical, plumbing, heating, air conditioning or other construction, location or relocation activity under any provision of general or special law pursuant to G.S. 130A-338.*



Mark RETH

This section for Local Health Department use only.

PART 2: LHD Completeness Review of the Notice of Intent to Construct

"(c) Completeness Review for Notice of Intent to Construct. -The local health department shall determine whether the notice of intent to construct required pursuant to subsection (b) of this section is complete within five business days after receiving the notice of intent to construct. A determination of completeness means that the notice of intent to construct includes all of the required components. If the local health department determines that the notice of intent to construct is incomplete, the local health department shall notify the owner and list the information needed to complete the notice. The owner may then submit additional information to the local health department to cure the deficiencies in the initial notice. The local health department shall make a final determination as to whether the notice of intent to construct is complete within five business days after the department receives the additional information. If the local health department fails to act within any time period set out in this subsection, the owner may treat the failure to act as a determination of completeness. The owner shall be able to apply for the building permit for the project upon the decision of completeness of the notice of intent by the local health department or if the local health department fails to act within the five business day time period."

The review for completeness of this Notice of Intent was conducted in accordance with G.S. 130A-336.2(c). This NOI is determined to be:

INCOMPLETE (If box is checked, Information in this section is required.)

Based upon review of information submitted in Part 1, the following items are missing: _____

Copies of this form listing missing items were sent to the LSS and the Owner on _____

via _____ with directions to re-submit missing items using Page 5 of this form.
Date
Email, FAX, USPS, hand-delivered

Print Name of Authorized Agent of the LHD *Signature of Authorized Agent of the LHD* *Date*

COMPLETE (If box is checked, information in this section is required.)

Based upon review of information submitted in Part 1 of this form, this NOI is deemed COMPLETE.

Copies of this signed form were sent to the LSS and the Owner on 9/8/21 via Email.
Date *Email, FAX, USPS, hand-delivered*

A copy of this NOI and tracking information was sent to the State on 9/8/21 via Email.
Date *Email, FAX, USPS, hand-delivered*

Mark A Osborne REHS [Signature] REHS 9/8/21
Print Name of Authorized Agent of the LHD *Signature of Authorized Agent of the LHD* *Date*

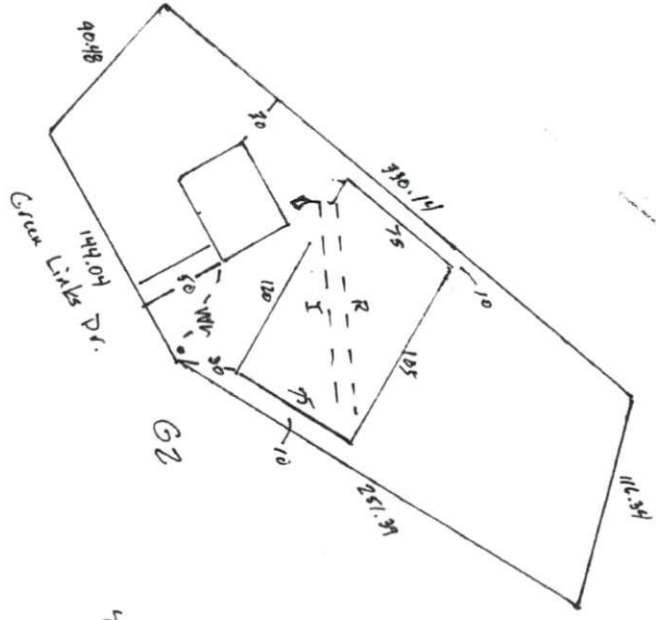

42' x 52' - 3 BDRM

1" = 100'



SOIL/SITE EVALUATION
 for ON-SITE WASTEWATER SYSTEM
 (Complete all fields in full)

OWNER: Deane Manning Realty Profit Sharing Plan APPLICATION DATE:
 ADDRESS: 2200 Premier Resort Blvd Unit B Ste 1B N Myrtle Beach SC 29582 DATE EVALUATED: 7-3-21
 PROPOSED FACILITY: 3 BDRM PROPOSED DESIGN FLOW (.1949): 360 PROPERTY SIZE: 1 ac
 LOCATION OF SITE: Carolina Seasons lot 62 PROPERTY RECORDED:
 WATER SUPPLY: Private Public Well Spring Other
 EVALUATION METHOD: Auger Boring Pit Cut TYPE OF WASTEWATER: Sewage Industrial Process Mixed

P R O F I L E #	.1940 LANDSCAPE POSITION/ SLOPE %	HORIZON DEPTH (IN.)	SOIL MORPHOLOGY (.1941)		OTHER PROFILE FACTORS				PROFILE CLASS & LTAR
			.1941 STRUCTURE/ TEXTURE	.1941 CONSISTENCE/ MINERALOGY	.1942 SOIL WETNESS/ COLOR	.1943 SOIL DEPTH	.1956 SAPR O CLASS	.1944 RESTR HORIZ	
12 3,4	LS 6-8%	0-48	gr ls	l exp	-	-	-	-	5 .8
2									
3									
4									

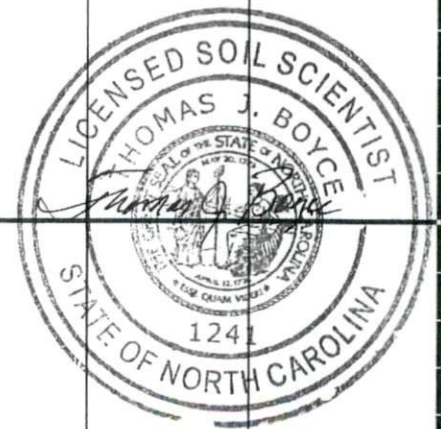

DESCRIPTION	INITIAL SYSTEM	REPAIR SYSTEM	OTHER FACTORS (.1946): <u>PS</u>
Available Space (.1945)	<u>PS</u>	<u>PS</u>	SITE CLASSIFICATION (.1948): <u>PS</u>
System Type(s)	<u>IIIg</u>	<u>IIIg</u>	EVALUATED BY: <u>TJB</u>
Site LTAR	<u>.8</u>	<u>.8</u>	OTHER(S) PRESENT: <u> </u>

COMMENTS: 1000 gal ST 112.5' x 8' x 30" Accepted