

FRONT ELEVATION
SCALE 1/4" = 1'-0"

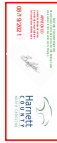

ATTIC VENTILATION:
THE NET FREE VENTILATING AREA SHALL BE NOT LESS THAN 1/10th OF THE AREA OF THE SPACE VENTILATED AT LEAST 10' FROM THE ROOF. THE REQUIRED VENTILATED AREA IS PROVIDED BY VENTILATORS LOCATED IN THE ATTIC AT LEAST 2 FEET ABOVE EAVE OR CORNER VENTS TO BE PROVIDED BY EAVE OR CORNER VENTS TO CROSS ATTIC AREA TO BE VENTILATED BY 32 SQ.FT.

1819/50 = 184 SQ.FT. NET FREE AREA

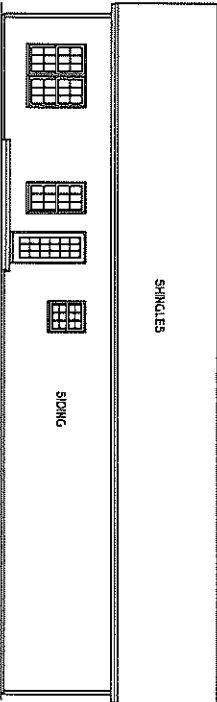

REAR ELEVATION
SCALE 1/8" = 1'-0"

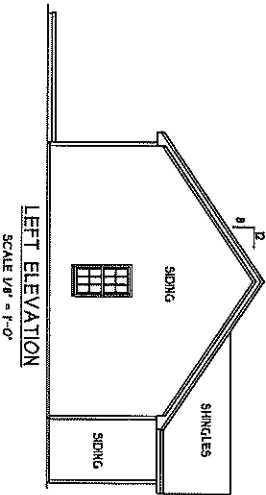

LEFT ELEVATION
SCALE 1/8" = 1'-0"

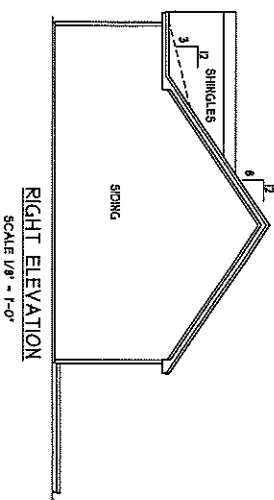

RIGHT ELEVATION
SCALE 1/8" = 1'-0"

ENERGY COMPLIANCE
R-VALUE = CEILING R-FACTOR .35
FLOORS R/F FOR JOHNSTON BAYNE COUNTY
ZONE 4 = MAX. GLAZING U-FACTOR .35
R-VALUE = CEILING PER WALLS PER
FLOORS R/F FOR WAKE COUNTY

FILE 020320	DATES 02/28/2020	H SQUARED HOME DESIGN, INC.	HEATHER HALL 185 HEATHERSTONE CT BENSON NC 27504 (818) 207-1403	SQUARE FOOTAGE: FIRST FLOOR = 1240 FRONT PORCH = 88 WOOD DECK = 144 GARAGE = 572	HEATED FOOTAGE: #1240	"THE DAKOTA II" (LEFT HAND GARAGE) JRT MANG. PROP.
				ANY DEVIATION OF THE SPECIFIED MEASUREMENTS OR MATERIALS SHALL BE THE RESPONSIBILITY OF THE CLIENT. H SQUARED HOME DESIGN, INC. IS NOT RESPONSIBLE FOR ANY CHANGES TO THE PLAN. THIS PLAN HAS BEEN DRAWN IN ACCORDANCE WITH NORTH CAROLINA STATE RESIDENTIAL BUILDING CODES 2008 EDITION.		

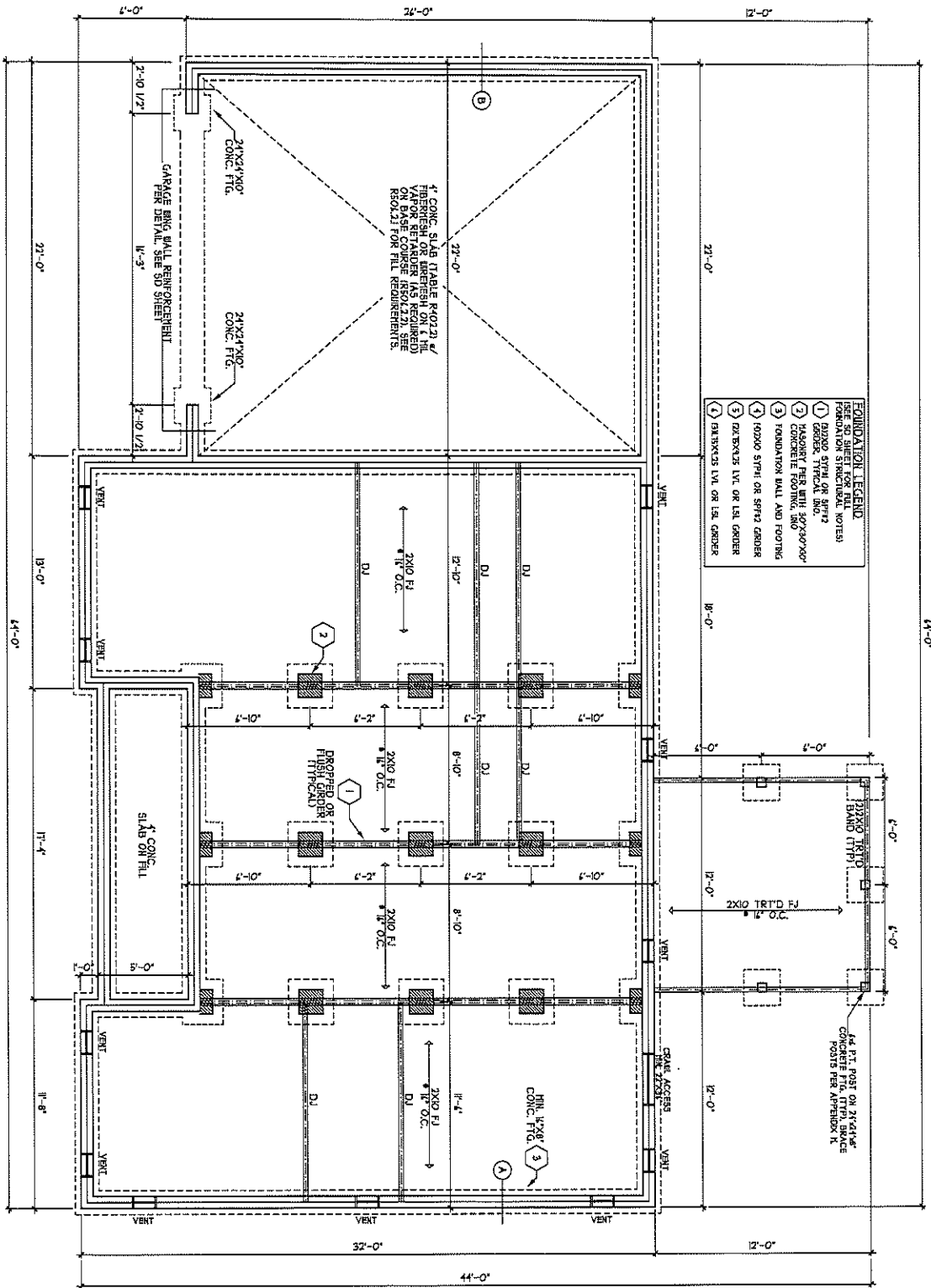

HEATHER HALL 185 HEATHERSTONE CT BENSON NC 27504 (919) 207-1403	H SQUARED HOME DESIGN, INC.	SQUARE FOOTAGE: FIRST FLOOR = 1240 FRONT PORCH = 88 WOOD DECK = 144 GARAGE = 572	HEATED FOOTAGE: #1240	"THE DAKOTA II" (LEFT HAND GARAGE) JRT MANG. PROP.
		DATE: 02/25/2020 1 STORY TITLE: 020320		

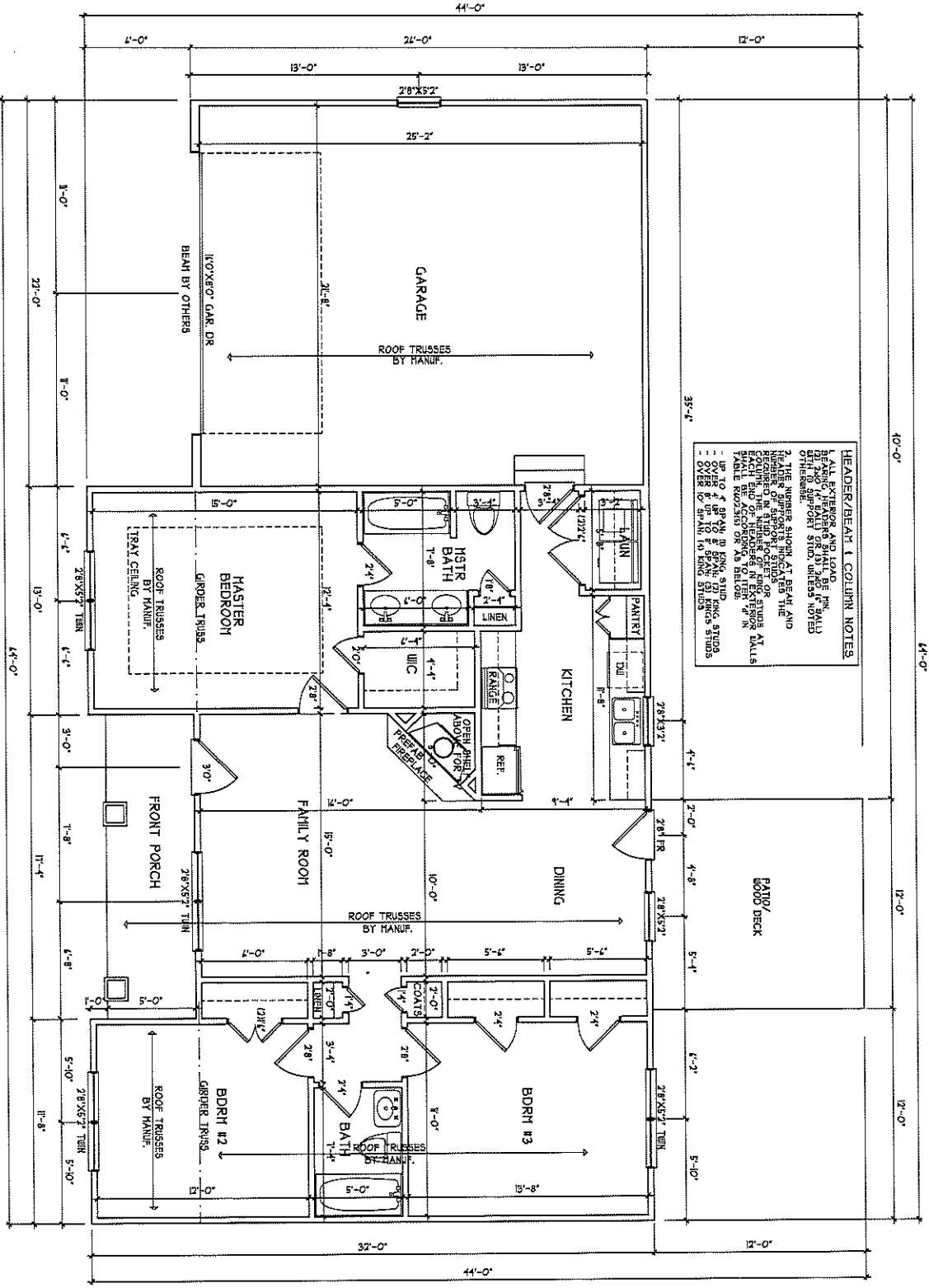

HEADER/BEAM & COLUMN NOTES

1. ALL HEADERS/BEAMS SHALL BE MIN. 2X8X5/2" UNLESS OTHERWISE NOTED.

2. THE NUMBER SHOWN AT EACH END AND NUMBER OF JOISTS SHALL BE THE NUMBER OF JOISTS TO BE SUPPORTED BY EACH END OF HEADER IN EXTENSION BAYS TABLE ROWS OR AS BELOW:

- UP TO 7 SPAN IN KING STUD
- OVER 7 UP TO 9 SPAN IN KING STUD
- OVER 9 UP TO 10 SPAN IN KING STUD
- OVER 10 SPAN IN KING STUD

REFER TO THE SHEETS FOR DETAILS AND STRUCTURAL NOTES

FIRST FLOOR PLAN

SCALE 1/4" = 1'-0"

 H SQUARED HOME DESIGN, INC.	HEATHER HALL 165 HEATHERSTONE CT BENSON NC 27504 (919) 207-1403	SQUARE FOOTAGE: FIRST FLOOR = 1240 FRONT PORCH = 85 WOOD DECK = 144 GARAGE = 572	HEATED FOOTAGE: #1240	"THE DAKOTA II" (LEFT HAND GARAGE) JRT MANG. PROP.	
	DATE: 02/25/2020	THIS PLAN HAS BEEN PREPARED BY AN ARCHITECT OR ARCHITECTURAL FIRM IN ACCORDANCE WITH THE CAROLINA STATE BOARD OF ARCHITECTURE.	ANY REVISIONS TO THIS PLAN SHALL BE INDICATED BY A REVISION NUMBER AND DATE.	THE ARCHITECT ASSUMES NO LIABILITY FOR THE PERFORMANCE OF ANY TRADES OR CONTRACTORS WORK.	THE ARCHITECT ASSUMES NO LIABILITY FOR THE PERFORMANCE OF ANY TRADES OR CONTRACTORS WORK.
	TEL: 020320 1 STORY	DATE: 02/25/2020	THIS PLAN HAS BEEN PREPARED BY AN ARCHITECT OR ARCHITECTURAL FIRM IN ACCORDANCE WITH THE CAROLINA STATE BOARD OF ARCHITECTURE.	ANY REVISIONS TO THIS PLAN SHALL BE INDICATED BY A REVISION NUMBER AND DATE.	THE ARCHITECT ASSUMES NO LIABILITY FOR THE PERFORMANCE OF ANY TRADES OR CONTRACTORS WORK.

TRUSS SYSTEM REQUIREMENTS
 1. ALL TRUSSES SHALL BE DESIGNED FOR THE FULL UNIFORM DEAD AND LIVE LOADS AS SPECIFIED IN ACCORDANCE WITH THE ROOFING MANUFACTURER'S REQUIREMENTS. ANY NEED TO CHANGE THE ROOF TRUSS TYPE SHALL BE APPROVED BY THE ARCHITECT.
 2. TRUSS SCHEMATICS (PROFILES) SHALL BE PREPARED AND SEALED BY TRUSS MANUFACTURER.
 3. ALL TRUSSES SHALL BE DESIGNED FOR THE FULL UNIFORM DEAD AND LIVE LOADS AS SPECIFIED IN ACCORDANCE WITH THE ROOFING MANUFACTURER'S REQUIREMENTS. ANY NEED TO CHANGE THE ROOF TRUSS TYPE SHALL BE APPROVED BY THE ARCHITECT.
 4. ALL REQUIRED ANCHORS FOR TRUSSES ARE TO BE SET OR BEARING SHALL MEET THE REQUIREMENTS AS SPECIFIED ON THE TRUSS SCHEMATICS.

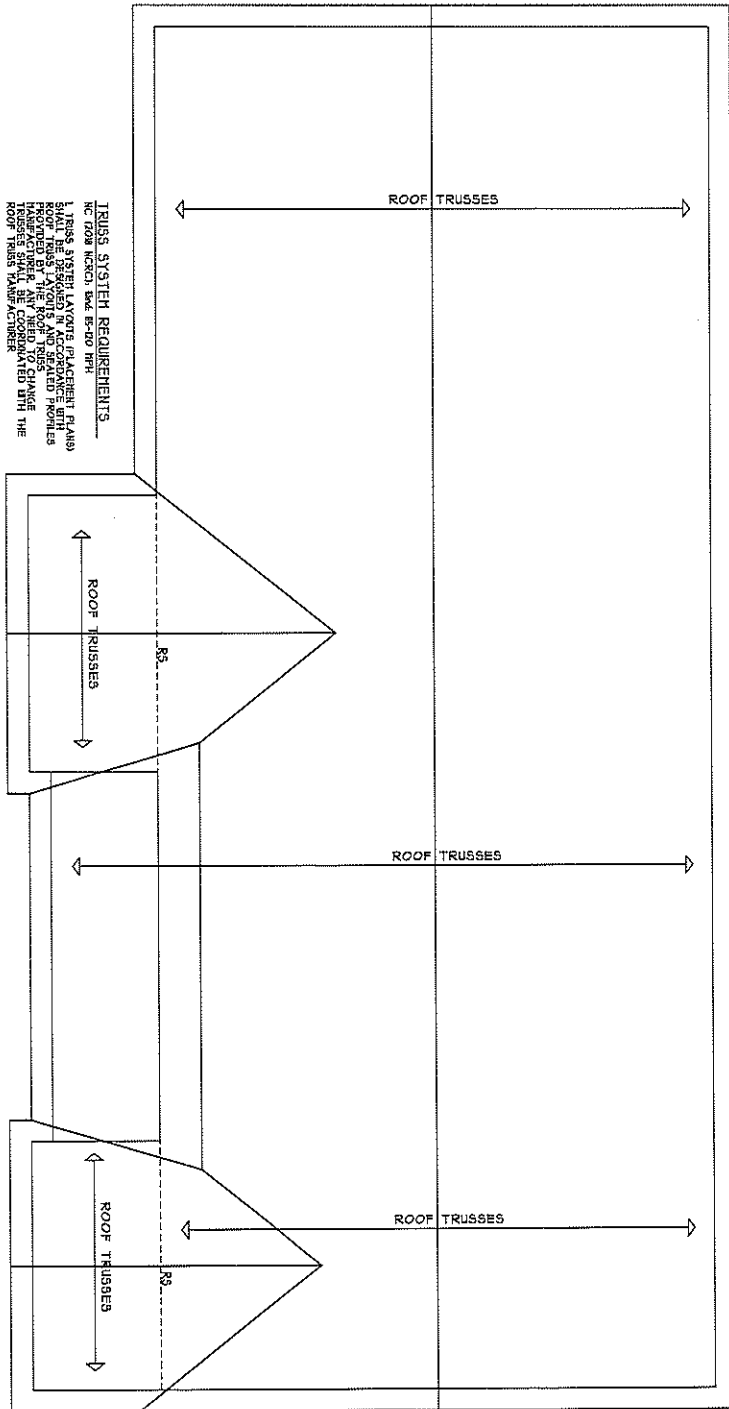

REFER TO THE SPECIFICATIONS FOR DETAILS AND STRUCTURAL NOTES

ROOF PLAN
 SCALE 1/4" = 1'-0"

 H SQUARED HOME DESIGN, INC.	HEATHER HALL 165 HEATHERSTONE CT BENSON NC 27504 (919) 207-1403	SQUARE FOOTAGE: FIRST FLOOR = 1240 FRONT PORCH = 86 WOOD DECK = 144 GARAGE = 572	HEATED FOOTAGE: #1240	"THE DAKOTA II" (LEFT HAND GARAGE) JRT MANG. PROP.
	DATE: 02/28/2020 ANY DEVIATION OF THE ORIGINAL DRAWINGS OR CHANGES TO THE DESIGN SHALL BE THE RESPONSIBILITY OF THE CLIENT. THIS PLAN HAS BEEN DRAWN IN ACCORDANCE WITH NORTH CAROLINA STATE RESIDENTIAL BUILDING CODES FOR PERMITS.	TEL: 020320 1 STORY		

Roof/Dropped Beams\FB1() (Dropped Beam)

Dry | 3 spans | No cant.

May 20, 2020 13:51:46

BC CALC® Member Report

Build 7493

Job name:

File name: 2000367A.mmdl

Address:

Description: Roof/Dropped Beams\FB1()

City, State, Zip:

Specifier:

Customer:

Designer:

Code reports: ESR-1040

Company:

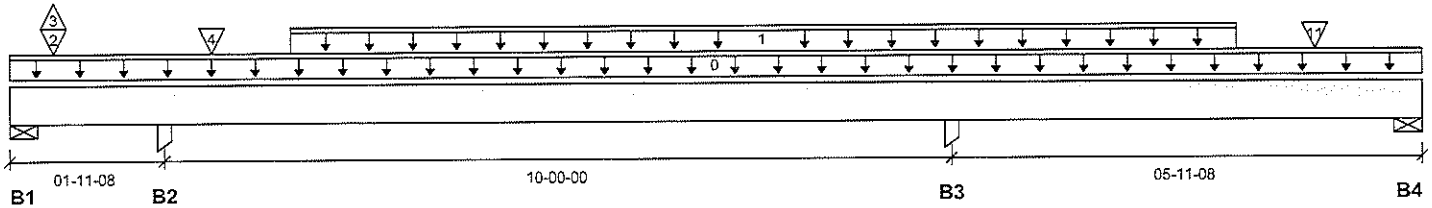

Reaction Summary (Down / Uplift) (lbs)

Bearing	Live	Dead	Snow	Wind	Roof Live
B1, 3-1/2"		0 / 242		290 / 77	71 / 380
B2, 5-1/2"		697 / 0		190 / 702	811 / 54
B3, 5-1/2"		602 / 0		161 / 594	653 / 0
B4, 3-1/2"		93 / 0		21 / 74	163 / 67

Load Summary

Tag	Description	Load Type	Ref.	Start	End	Loc.	Live 100%	Dead 90%	Snow 115%	Wind 160%	Roof Live 125%	Tributary
0	Self-Weight	Unf. Lin. (lb/ft)	L	00-00-00	17-11-00	Top		9				00-00-00
1	Smoothed Load	Unf. Lin. (lb/ft)	L	03-06-12	15-06-12	Top		57			72	n/a
2	M1(c1)	Conc. Pt. (lbs)	L	00-06-12	00-06-12	Top		64			50	n/a
3	M1(c1)	Conc. Pt. (lbs)	L	00-06-12	00-06-12	Top					-21	n/a
4	M1(c1)	Conc. Pt. (lbs)	L	02-06-12	02-06-12	Top		126			168	n/a
11	M1(c1)	Conc. Pt. (lbs)	L	16-06-12	16-06-12	Top		102			130	n/a

Controls Summary

	Value	% Allowable	Duration	Case	Location
Pos. Moment	779 ft-lbs	4.7%	125%	4	06-06-12
Neg. Moment	-1155 ft-lbs	7.1%	125%	5	01-11-08
End Shear	576 lbs	7.5%	125%	4	01-00-12
Cont. Shear	689 lbs	9.0%	125%	5	00-11-08
Total Load Deflection	L/999 (0.022")	n/a	n/a	4	07-00-12
Live Load Deflection	L/999 (0.012")	n/a	n/a	312	07-02-04
Total Neg. Defl.	L/999 (-0.003")	n/a	n/a	4	13-10-15
Max Defl.	0.022"	n/a	n/a	4	07-00-12
Span / Depth	13.0				

Bearing Supports

	Dim. (LxW)	Value	% Allow Support	% Allow Member	Material
B1	Wall/Plate 3-1/2" x 3-1/2"	29 lbs	0.6%	0.3%	Spruce-Pine-Fir
B1	Uplift	622 lbs			
B2	Column 5-1/2" x 3-1/2"	1508 lbs	10.8%	10.4%	Unspecified
B3	Column 5-1/2" x 3-1/2"	1255 lbs	9.0%	8.7%	Unspecified
B4	Wall/Plate 3-1/2" x 3-1/2"	256 lbs	4.9%	2.8%	Spruce-Pine-Fir

Cautions

Uplift of -622 lbs found at bearing B1.

BC CALC® Member Report
 Build 7493
 Job name:
 Address:
 City, State, Zip:
 Customer:
 Code reports: ESR-1040

File name: 2000367A.mmdl
 Description: RoofDropped Beams\FB1()
 Specifier:
 Designer:
 Company:

Notes

Design meets Code minimum (L/240) Total load deflection criteria.
 Design meets Code minimum (L/360) Live load deflection criteria.
 Design meets arbitrary (1") Maximum Total load deflection criteria.
 Design meets arbitrary (0.75") Maximum live load deflection criteria.
 Calculations assume unbraced length of Top: 01-10-08, Bottom: 01-10-08.
 BC CALC® analysis is based on IBC 2012.
 Wind loads determined from building geometry were used in selected product's verification.
 Design based on Dry Service Condition.

Connection Diagram: Full Length of Member

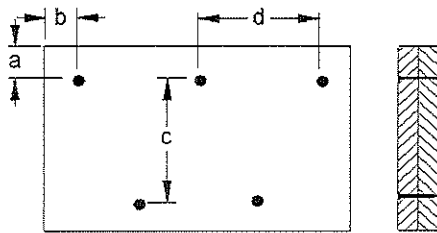

a minimum = 2" c = 5-1/4"
 b minimum = 3" d = 24"

Connectors are: 3-1/4 in. Pneumatic Gun Nails

Disclosure

Use of the Boise Cascade Software is subject to the terms of the End User License Agreement (EULA). Completeness and accuracy of input must be reviewed and verified by a qualified engineer or other appropriate expert to assure its adequacy, prior to anyone relying on such output as evidence of suitability for a particular application. The output here is based on building code-accepted design properties and analysis methods. Installation of Boise Cascade engineered wood products must be in accordance with current Installation Guide and applicable building codes. To obtain Installation Guide or ask questions, please call (800)232-0788 before installation.

BC CALC®, BC FRAMER®, AJS™, ALLJOIST®, BC RIM BOARD™, BCI®, BOISE GLULAM™, BC FloorValue®, VERSA-LAM®, VERSA-RIM PLUS®,

Roof/Dropped Beams\GDH(i19) (Dropped Beam)

BC CALC® Member Report

Dry | 1 span | No cant.

May 20, 2020 13:51:46

Build 7493

Job name:

File name: 2000367A.mmdl

Address:

Description: Roof/Dropped Beams\GDH(i19)

City, State, Zip:

Specifier:

Customer:

Designer:

Code reports: ESR-1040

Company:

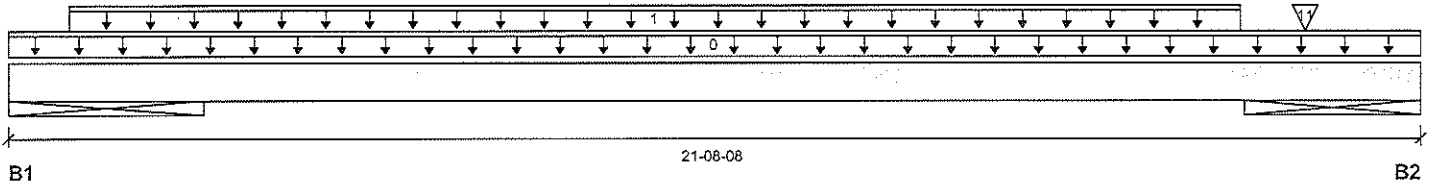

Reaction Summary (Down / Uplift) (lbs)

Bearing	Live	Dead	Snow	Wind	Roof Live
B1, 36"		2891 / 0		1374 / 1950	2804 / 0
B2, 32-1/2"		2878 / 0		1383 / 1999	2811 / 0

Load Summary

Tag	Description	Load Type	Ref.	Start	End	Loc.	100%	90%	115%	160%	Roof Live 125%	Tributary
0	Self-Weight	Unf. Lin. (lb/ft)	L	00-00-00	21-08-08	Top		18				00-00-00
1	Smoothed Load	Unf. Lin. (lb/ft)	L	00-11-04	18-11-04	Top		268			279	n/a
11	A(c1)	Conc. Pt. (lbs)	L	19-11-04	19-11-04	Top		557			600	n/a

Controls Summary

	Value	% Allowable	Duration	Case	Location
Pos. Moment	17173 ft-lbs	44.1%	125%	1	11-11-04
End Shear	3425 lbs	23.1%	125%	1	03-11-14
Total Load Deflection	L/356 (0.544")	67.5%	n/a	1	10-11-04
Live Load Deflection	L/718 (0.27")	50.2%	n/a	116	10-11-04
Max Defl.	0.544"	54.4%	n/a	1	10-11-04
Span / Depth	16.3				
Conc. Load (B1)	1107 lbs	8.0%	100%		
Conc. Load (B2)	1157 lbs	8.4%	100%		

Bearing Supports

	Dim. (LxW)	Value	% Allow Support	% Allow Member	Material
B1	Wall/Plate 36" x 5-1/4"	5695 lbs	4.2%	4.0%	Unspecified
B2	Wall/Plate 32-1/2" x 5-1/4"	5689 lbs	7.8%	4.4%	Spruce-Pine-Fir

Notes

Design meets Code minimum (L/240) Total load deflection criteria.
 Design meets Code minimum (L/360) Live load deflection criteria.
 Design meets arbitrary (1") Maximum Total load deflection criteria.
 Design meets arbitrary (0.75") Maximum live load deflection criteria.
 Calculations assume unbraced length of Top: 01-10-08, Bottom: 01-10-08.
 BC CALC® analysis is based on IBC 2012.
 Wind loads determined from building geometry were used in selected product's verification.
 Design based on Dry Service Condition.

BC CALC® Member Report

Build 7493

Job name:

File name: 2000367A.mmdl

Address:

Description: RoofDropped Beams\GDH(i19)

City, State, Zip:

Specifier:

Customer:

Designer:

Code reports: ESR-1040

Company:

Connection Diagram: Full Length of Member

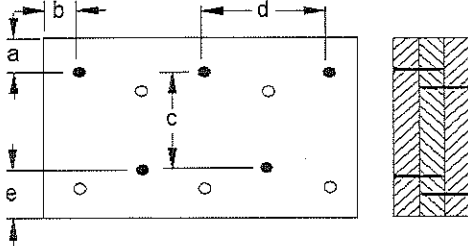

a minimum = 2" c = 7-7/8"
 b minimum = 3" d = 24"
 e minimum = 3"

Nailing applies to both sides of the member
 Connectors are: 3-1/4 in. Pneumatic Gun Nails

Disclosure

Use of the Boise Cascade Software is subject to the terms of the End User License Agreement (EULA). Completeness and accuracy of input must be reviewed and verified by a qualified engineer or other appropriate expert to assure its adequacy, prior to anyone relying on such output as evidence of suitability for a particular application. The output here is based on building code-accepted design properties and analysis methods. Installation of Boise Cascade engineered wood products must be in accordance with current Installation Guide and applicable building codes. To obtain Installation Guide or ask questions, please call (800)232-0788 before installation.

BC CALC®, BC FRAMER®, AJS™, ALLJOIST®, BC RIM BOARD™, BCI®, BOISE GLULAM™, BC FloorValue®, VERSA-LAM®, VERSA-RIM PLUS®,

Trenco

818 Soundside Rd
Edenton, NC 27932

Re: 2000367-2000367A
2307- JRT -DAKOTA II

The truss drawing(s) referenced below have been prepared by Truss Engineering Co. under my direct supervision based on the parameters provided by 84 Components - #2383.

Pages or sheets covered by this seal: I41377982 thru I41378003

My license renewal date for the state of North Carolina is December 31, 2020.

North Carolina COA: C-0844

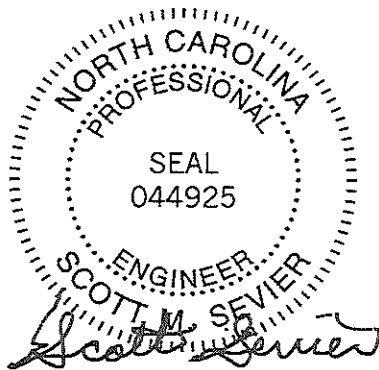

May 21, 2020

Sevier, Scott

IMPORTANT NOTE: The seal on these truss component designs is a certification that the engineer named is licensed in the jurisdiction(s) identified and that the designs comply with ANSI/TPI 1. These designs are based upon parameters shown (e.g., loads, supports, dimensions, shapes and design codes), which were given to MiTek or TRENCO. Any project specific information included is for MiTek's or TRENCO's customers file reference purpose only, and was not taken into account in the preparation of these designs. MiTek or TRENCO has not independently verified the applicability of the design parameters or the designs for any particular building. Before use, the building designer should verify applicability of design parameters and properly incorporate these designs into the overall building design per ANSI/TPI 1, Chapter 2.

Job 2000367-2000367A	Truss A	Truss Type ROOF TRUSS	Qty 10	Ply 1	2307- JRT -DAKOTA II	141377982
-------------------------	------------	--------------------------	-----------	----------	----------------------	-----------

84 Components (Dunn), Dunn, NC - 28334.

8.330 s May 6 2020 MiTek Industries, Inc. Wed May 20 13:01:53 2020 Page 1

ID:ceuvEDckNGn_oUaH?G0U8dzEclS-SLjawnL7XTJun8gGxhDR6I5kiJenG7ZlBzrNLzEbj

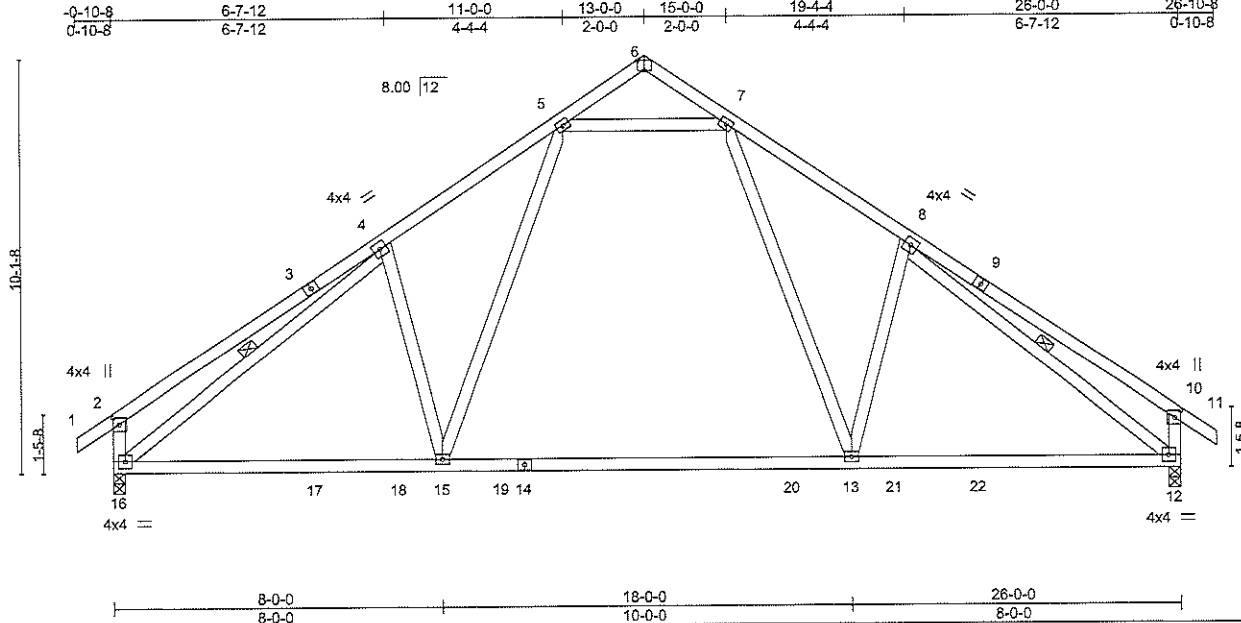

Plate Offsets (X,Y)-	[2:0-2-0.0-1-12], [6:0-2-0.Edge], [10:0-2-0.0-1-12]
----------------------	---

LOADING (psf)	SPACING-	CSL	DEFL.	PLATES	GRIP
TCLL 20.0	2-0-0	TC 0.64	in (loc) l/defl L/d	MT20	244/190
TCDL 10.0	Plate Grip DOL 1.15	BC 0.76	Vert(LL) -0.39 13-15 >798 240		
BCLL 0.0 *	Lumber DOL 1.15	WB 0.44	Vert(CT) -0.56 13-15 >551 180		
BCDL 10.0	Rep Stress Incr YES	Matrix-S	Horz(CT) 0.03 12 n/a n/a		
	Code IRC2015/TPI2014			Weight: 164 lb	FT = 20%

LUMBER-	BRACING-
TOP CHORD 2x4 SP No.2	TOP CHORD Structural wood sheathing directly applied or 4-9-12 oc purlins, except end verticals.
BOT CHORD 2x4 SP No.1	BOT CHORD Rigid ceiling directly applied or 10-0-0 oc bracing.
WEBS 2x4 SP No.3	WEBS 1 Row at midpt 4-16, 8-12

REACTIONS. (size) 16=0-3-8, 12=0-3-8
 Max Horz 16=273(LC 11)
 Max Uplift 16=-126(LC 12), 12=-126(LC 13)
 Max Grav 16=1165(LC 20), 12=1165(LC 21)

FORCES. (lb) - Max. Comp./Max. Ten. - All forces 250 (lb) or less except when shown.
 TOP CHORD 2-4=-381/239, 4-5=-1323/338, 7-8=-1323/338, 8-10=-381/239, 2-16=-403/228, 10-12=-402/228
 BOT CHORD 15-16=-130/1191, 13-15=-11/927, 12-13=-82/1056
 WEBS 7-13=-152/617, 8-13=-265/281, 5-15=-151/617, 4-15=-265/281, 4-16=-1197/24, 8-12=-1196/24, 5-7=-791/286

- NOTES-**
- Unbalanced roof live loads have been considered for this design.
 - Wind: ASCE 7-10; Vult=130mph (3-second gust) Vasd=103mph; TCDL=6.0psf; BCDL=6.0psf; h=30ft; Cat. II; Exp B; Enclosed; MWFRS (envelope) gable end zone and C-C Exterior(2) zone; cantilever left and right exposed; end vertical left and right exposed; C-C for members and forces & MWFRS for reactions shown; Lumber DOL=1.60 plate grip DOL=1.60
 - All plates are 3x4 MT20 unless otherwise indicated.
 - This truss has been designed for a 10.0 psf bottom chord live load nonconcurrent with any other live loads.
 - * This truss has been designed for a live load of 20.0psf on the bottom chord in all areas where a rectangle 3-6-0 tall by 2-0-0 wide will fit between the bottom chord and any other members, with BCDL = 10.0psf.
 - One H2.5A Simpson Strong-Tie connectors recommended to connect truss to bearing walls due to UPLIFT at jt(s) 16 and 12. This connection is for uplift only and does not consider lateral forces.
 - ATTIC SPACE SHOWN IS DESIGNED AS UNINHABITABLE.

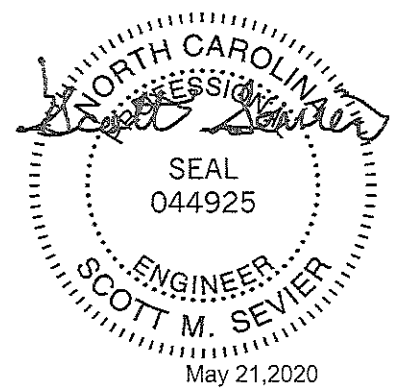

<p>WARNING - Verify design parameters and READ NOTES ON THIS AND INCLUDED MITEK REFERENCE PAGE MII-7473 rev. 10/03/2015 BEFORE USE.</p> <p>Design valid for use only with MiTek® connectors. This design is based only upon parameters shown, and is for an individual building component, not a truss system. Before use, the building designer must verify the applicability of design parameters and properly incorporate this design into the overall building design. Bracing indicated is to prevent buckling of individual truss web and/or chord members only. Additional temporary and permanent bracing is always required for stability and to prevent collapse with possible personal injury and property damage. For general guidance regarding the fabrication, storage, delivery, erection and bracing of trusses and truss systems, see ANSITPH Quality Criteria, DSB-89 and BCSI Building Component Safety Information available from Truss Plate Institute, 218 N. Lee Street, Suite 312, Alexandria, VA 22314.</p>	<p>ENGINEERING BY TRENCO <small>A MiTek Affiliate</small></p> <p>818 Soundside Road Edenton, NC 27932</p>
--	--

Job 2000367-2000367A	Truss A1	Truss Type Common	Qty 2	Ply 1	2307- JRT -DAKOTA II	I41377983
-------------------------	-------------	----------------------	----------	----------	----------------------	-----------

84 Components (Dunn), Dunn, NC - 28334,

8.330 s May 6 2020 MiTek Industries, Inc. Wed May 20 13:01:54 2020 Page 1

ID:ceuvEDckNGn_oUaH?G0U8dzEclS-xXGy7GMlInsPljsqfCSzJrHZ8efWiOjXriPvozEbjh

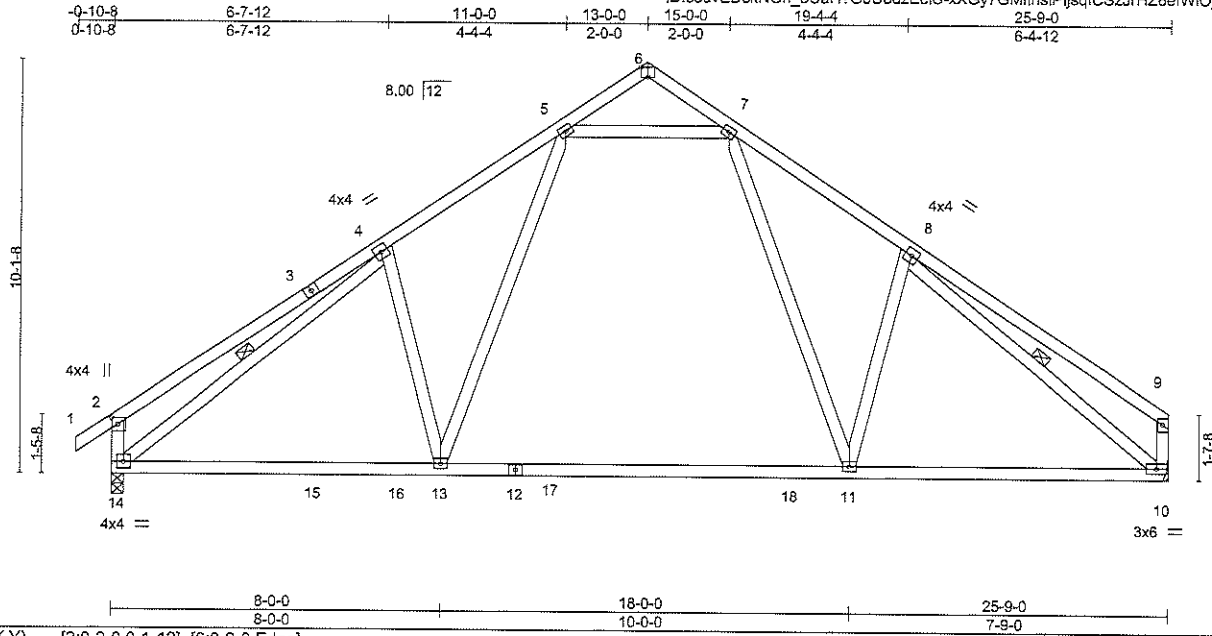

LOADING (psf)	SPACING- 2-0-0	CSI	DEFL.	PLATES	GRIP
TCLL 20.0	Plate Grip DOL 1.15	TC 0.63	in (loc) l/defl L/d	MT20	244/190
TCDL 10.0	Lumber DOL 1.15	BC 0.77	Vert(LL) -0.42 11-13 >728 240		
BCLL 0.0 *	Rep Stress Incr YES	WB 0.44	Vert(CT) -0.59 11-13 >514 180		
BCDL 10.0	Code IRC2015/TPI2014	Matrix-MS	Horz(CT) 0.03 10 n/a n/a		
				Weight: 161 lb	FT = 20%

LUMBER-	BRACING-
TOP CHORD 2x4 SP No.2	TOP CHORD Structural wood sheathing directly applied or 4-8-2 oc purlins, except end verticals.
BOT CHORD 2x4 SP No.1	BOT CHORD Rigid ceiling directly applied or 10-0-0 oc bracing.
WEBS 2x4 SP No.3	WEBS 1 Row at midpt 4-14, 8-10

REACTIONS. (size) 14=0-3-8, 10=Mechanical
 Max Horz 14=270(LC 11)
 Max Uplift 14=-125(LC 12), 10=-103(LC 13)
 Max Grav 14=1142(LC 19), 10=1049(LC 20)

FORCES. (lb) - Max. Comp./Max. Ten. - All forces 250 (lb) or less except when shown.
 TOP CHORD 2-4=-369/232, 4-5=-1291/330, 7-8=-1237/329, 8-9=-255/166, 2-14=-392/223, 9-10=-267/148
 BOT CHORD 13-14=-144/1158, 11-13=-43/883, 10-11=-123/975
 WEBS 4-13=-262/277, 5-13=-144/626, 7-11=-140/526, 8-11=-236/271, 4-14=-1174/29, 8-10=-1218/107, 5-7=-762/287

- NOTES-**
- 1) Unbalanced roof live loads have been considered for this design.
 - 2) Wind: ASCE 7-10; Vult=130mph (3-second gust) Vasd=103mph; TCCL=6.0psf; BCDL=6.0psf; h=30ft; Cat. II; Exp B; Enclosed; MWFRS (envelope) gable end zone and C-C Exterior(2) zone; cantilever left and right exposed; end vertical left and right exposed; C-C for members and forces & MWFRS for reactions shown; Lumber DOL=1.60 plate grip DOL=1.60
 - 3) All plates are 3x4 MT20 unless otherwise indicated.
 - 4) This truss has been designed for a 10.0 psf bottom chord live load nonconcurrent with any other live loads.
 - 5) * This truss has been designed for a live load of 20.0psf on the bottom chord in all areas where a rectangle 3-6-0 tall by 2-0-0 wide will fit between the bottom chord and any other members, with BCDL = 10.0psf.
 - 6) Refer to girder(s) for truss to truss connections.
 - 7) Provide mechanical connection (by others) of truss to bearing plate capable of withstanding 100 lb uplift at joint(s) except (it=lb) 10=103.
 - 8) One H2.5A Simpson Strong-Tie connectors recommended to connect truss to bearing walls due to UPLIFT at jt(s) 14. This connection is for uplift only and does not consider lateral forces.

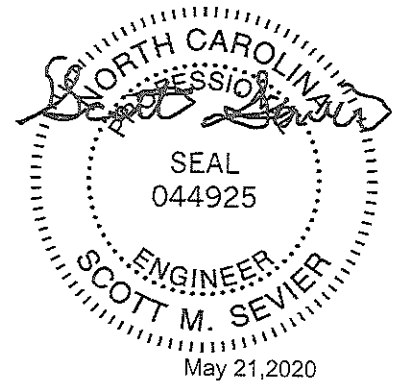

Job	Truss	Truss Type	Qty	Ply	2307- JRT -DAKOTA II	141377984
2000367-2000367A	A1E	Common Supported Gable	1	1	Job Reference (optional)	

84 Components (Dunn), Dunn, NC - 28334, 8.330 s May 6 2020 MiTek Industries, Inc. Wed May 20 13:01:57 2020 Page 1
 ID:ceuvEDckNgN_oUaH?G0U8dzEclS-L6y5llOdaiEKGRVnm9byTtJq7j7k9Dpx3W7zEbj

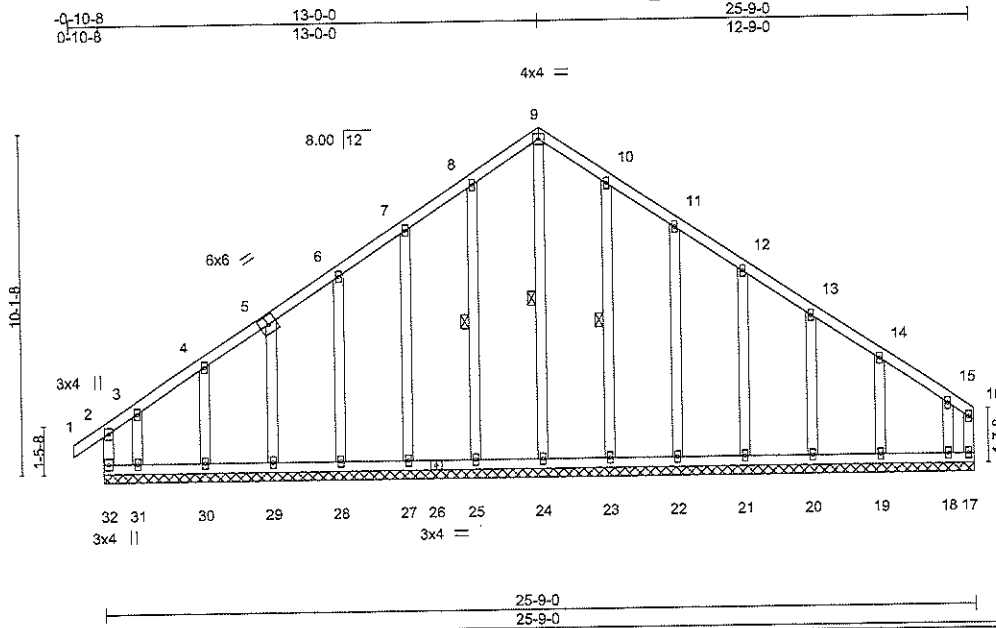

Scale = 1:65.6

LOADING (psf)	SPACING-	CSI.	DEFL.	PLATES	GRIP
TCLL 20.0	2-0-0	TC 0.28	in (loc) l/defl L/d	MT20	244/190
TCDL 10.0	Plate Grip DOL 1.15	BC 0.15	Vert(LL) -0.00 1 n/r 120		
BCLL 0.0	Lumber DOL 1.15	WB 0.14	Vert(CT) -0.00 1 n/r 90		
BCDL 10.0	Rep Stress Incr YES	Matrix-R	Horz(CT) -0.00 17 n/a n/a		
	Code IRC2015/TPI2014			Weight: 191 lb	FT = 20%

LUMBER-
 TOP CHORD 2x4 SP No.2
 BOT CHORD 2x4 SP No.2
 WEBS 2x4 SP No.3
 OTHERS 2x4 SP No.3

BRACING-
 TOP CHORD Structural wood sheathing directly applied or 6-0-0 oc purlins, except end verticals.
 BOT CHORD Rigid ceiling directly applied or 6-0-0 oc bracing, Except: 10-0-0 oc bracing: 31-32,30-31,29-30.
 WEBS 1 Row at midpt 9-24, 8-25, 10-23

REACTIONS. All bearings 25-9-0.
 (lb) - Max Horz 32=270(LC 9)
 Max Uplift All uplift 100 lb or less at joint(s) 25, 27, 28, 29, 30, 23, 22, 21, 20, 19 except 32=281(LC 8), 17=302(LC 11), 31=282(LC 9), 18=268(LC 8)
 Max Grav All reactions 250 lb or less at joint(s) 25, 27, 28, 29, 30, 23, 22, 21, 20, 19 except 32=335(LC 9), 17=306(LC 8), 24=270(LC 13), 31=332(LC 10), 18=349(LC 11)

FORCES. (lb) - Max. Comp./Max. Ten. - All forces 250 (lb) or less except when shown.
 TOP CHORD 7-8=-221/274, 8-9=-265/324, 9-10=-265/324, 10-11=-222/274
 WEBS 9-24=-291/175

- NOTES-**
- Unbalanced roof live loads have been considered for this design.
 - Wind: ASCE 7-10; Vult=130mph (3-second gust) Vasd=103mph; TCDL=6.0psf; BCDL=6.0psf; h=30ft; Cat. II; Exp B; Enclosed; MWFRS (envelope) gable end zone and C-C Exterior(2) zone; cantilever left and right exposed; end vertical left and right exposed; C-C for members and forces & MWFRS for reactions shown; Lumber DOL=1.60 plate grip DOL=1.60
 - Truss designed for wind loads in the plane of the truss only. For studs exposed to wind (normal to the face), see Standard Industry Gable End Details as applicable, or consult qualified building designer as per ANSI/TPI 1.
 - All plates are 2x4 MT20 unless otherwise indicated.
 - Gable requires continuous bottom chord bearing.
 - Truss to be fully sheathed from one face or securely braced against lateral movement (i.e. diagonal web).
 - Gable studs spaced at 2-0-0 oc.
 - This truss has been designed for a 10.0 psf bottom chord live load nonconcurrent with any other live loads.
 - * This truss has been designed for a live load of 20.0psf on the bottom chord in all areas where a rectangle 3-6-0 tall by 2-0-0 wide will fit between the bottom chord and any other members.
 - One H2.5A Simpson Strong-Tie connectors recommended to connect truss to bearing walls due to UPLIFT at jt(s) 32, 17, 25, 27, 28, 29, 30, 31, 23, 22, 21, 20, 19, and 18. This connection is for uplift only and does not consider lateral forces.

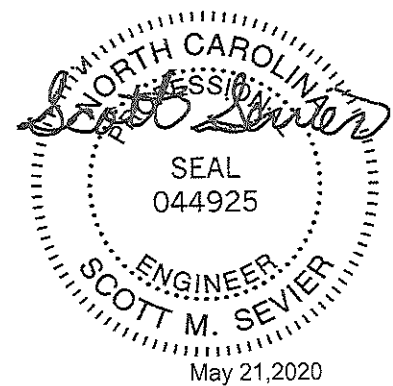

WARNING - Verify design parameters and READ NOTES ON THIS AND INCLUDED MITEK REFERENCE PAGE MII-7473 rev. 10/03/2015 BEFORE USE.
 Design valid for use only with MiTek® connectors. This design is based only upon parameters shown, and is for an individual building component, not a truss system. Before use, the building designer must verify the applicability of design parameters and properly incorporate this design into the overall building design. Bracing indicated is to prevent buckling of individual truss web and/or chord members only. Additional temporary and permanent bracing is always required for stability and to prevent collapse with possible personal injury and property damage. For general guidance regarding the fabrication, storage, delivery, erection and bracing of trusses and truss systems, see ANSI/TPI1 Quality Criteria, DSB-89 and BCSI Building Component Safety Information available from Truss Plate Institute, 218 N. Lee Street, Suite 312, Alexandria, VA 22314.

ENGINEERING BY
TRENCO
 A MiTek Affiliate
 818 Soundside Road
 Edenon, NC 27932

Job	Truss	Truss Type	Qty	Ply	2307- JRT -DAKOTA II	I41377985
2000367-2000367A	A2	Roof Special	4	1		

84 Components (Dunn),

Dunn, NC - 28334,

Job Reference (optional)

8.330 s May 6 2020 MiTek Industries, Inc. Wed May 20 13:01:58 2020 Page 1

ID:ceuvEDckNGn_oUaH?GOU8dzEclS-pJWtYePFL?MBtv0e3UHO89?_6j?6SU3JSTgc2ZzEbjd

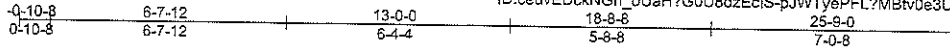

Scale = 1:62.7

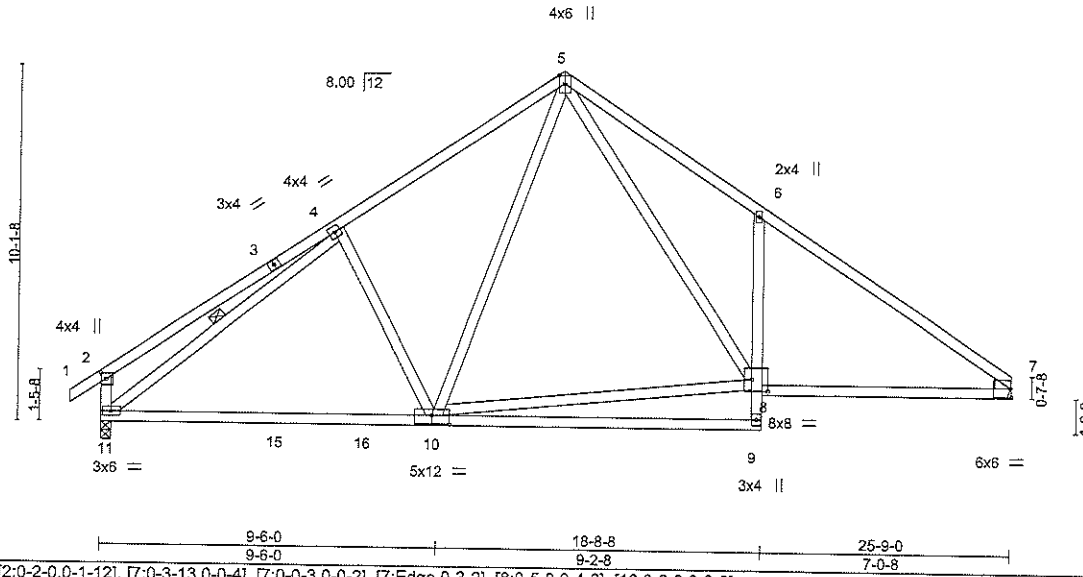

Plate Offsets (X,Y)-	[2:0-2-0,0-1-12], [7:0-3-13,0-0-4], [7:0-0-3,0-0-2], [7:Edge,0-3-2], [8:0-5-8,0-4-0], [10:0-6-0,0-3-0]
----------------------	--

LOADING (psf)	SPACING-	CSI.	DEFL.	PLATES	GRIP
TCLL 20.0	Truss Grip DOL 2-0-0	TC 0.54	in (loc) l/defl L/d	MT20	244/190
TCDL 10.0	Plate Grip DOL 1.15	BC 0.87	Vert(LL) -0.17 10-11 >999 240		
BCLL 0.0 *	Lumber DOL 1.15	WB 0.52	Vert(CT) -0.34 9-10 >917 180		
BCDL 10.0	Rep Stress Incr YES	Matrix-MS	Horz(CT) 0.03 7 n/a n/a		
	Code IRC2015/TPI2014			Weight: 161 lb	FT = 20%

LUMBER-	BRACING-
TOP CHORD 2x4 SP No.2	TOP CHORD Structural wood sheathing directly applied or 4-3-8 oc purlins, except end verticals.
BOT CHORD 2x4 SP No.2 *Except* 6-9: 2x4 SP No.3	BOT CHORD Rigid ceiling directly applied or 10-0-0 oc bracing.
WEBS 2x4 SP No.3	WEBS 1 Row at midpt 4-11
WEDGE	
Right: 2x4 SP No.3	

REACTIONS. (size) 11=0-3-8, 7=Mechanical
 Max Horz 11=-250(LC 10)
 Max Uplift 11=-125(LC 12), 7=-104(LC 13)
 Max Grav 11=1087(LC 1), 7=1023(LC 1)

FORCES. (lb) - Max. Comp./Max. Ten. - All forces 250 (lb) or less except when shown.
 TOP CHORD 2-4=-380/197, 4-5=-1106/324, 5-6=-1426/447, 6-7=-1459/270, 2-11=-403/196
 BOT CHORD 10-11=-185/1016, 6-8=-422/297, 7-8=-119/1127
 WEBS 4-10=-280/266, 5-10=-111/458, 8-10=-39/659, 5-8=-257/776, 4-11=-990/85

- NOTES-**
- 1) Unbalanced roof live loads have been considered for this design.
 - 2) Wind: ASCE 7-10; Vult=130mph (3-second gust) Vasd=103mph; TCDL=6.0psf; BCDL=6.0psf; h=30ft; Cat. II; Exp B; Enclosed; MWFRS (envelope) gable end zone and C-C Exterior(2) zone; cantilever left and right exposed; end vertical left and right exposed; C-C for members and forces & MWFRS for reactions shown; Lumber DOL=1.60 plate grip DOL=1.60
 - 3) This truss has been designed for a 10.0 psf bottom chord live load nonconcurrent with any other live loads.
 - 4) * This truss has been designed for a live load of 20.0psf on the bottom chord in all areas where a rectangle 3-6-0 tall by 2-0-0 wide will fit between the bottom chord and any other members, with BCDL = 10.0psf.
 - 5) Refer to girder(s) for truss to truss connections.
 - 6) Provide mechanical connection (by others) of truss to bearing plate capable of withstanding 100 lb uplift at joint(s) except (jt=lb) 7=104.
 - 7) One H2.5A Simpson Strong-Tie connectors recommended to connect truss to bearing walls due to UPLIFT at jt(s) 11. This connection is for uplift only and does not consider lateral forces.

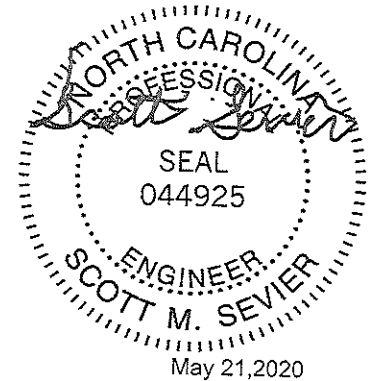

WARNING - Verify design parameters and READ NOTES ON THIS AND INCLUDED MITEK REFERENCE PAGE MII-7473 rev. 10/03/2015 BEFORE USE.
 Design valid for use only with MiTek® connectors. This design is based only upon parameters shown, and is for an individual building component, not a truss system. Before use, the building designer must verify the applicability of design parameters and properly incorporate this design into the overall building design. Bracing indicated is to prevent buckling of individual truss web and/or chord members only. Additional temporary and permanent bracing is always required for stability and to prevent collapse with possible personal injury and property damage. For general guidance regarding the fabrication, storage, delivery, erection and bracing of trusses and truss systems, see ANSITPH Quality Criteria, DSB-89 and BCSI Building Component Safety Information available from Truss Plate Institute, 218 N. Lee Street, Suite 312, Alexandria, VA 22314.

ENGINEERING BY
TRENCO
 A MiTek Affiliate
 818 Soundside Road
 Edenton, NC 27932

Job	Truss	Truss Type	Qty	Ply	2307- JRT -DAKOTA II	I41377986
2000367-2000367A	A3	ROOF TRUSS	8	1	Job Reference (optional)	

84 Components (Dunn), Dunn, NC - 28334,

8.330 s May 6 2020 Mitek Industries, Inc. Wed May 20 13:02:00 2020 Page 1

ID:ceuvEDckNGn_oUaH?G0U8dzEcIS-lheENJRWtdcv7DA0BvJsDa5JNXiFwPSbvn9j7RzEbjb

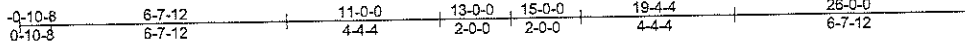

Scale = 1:62.7

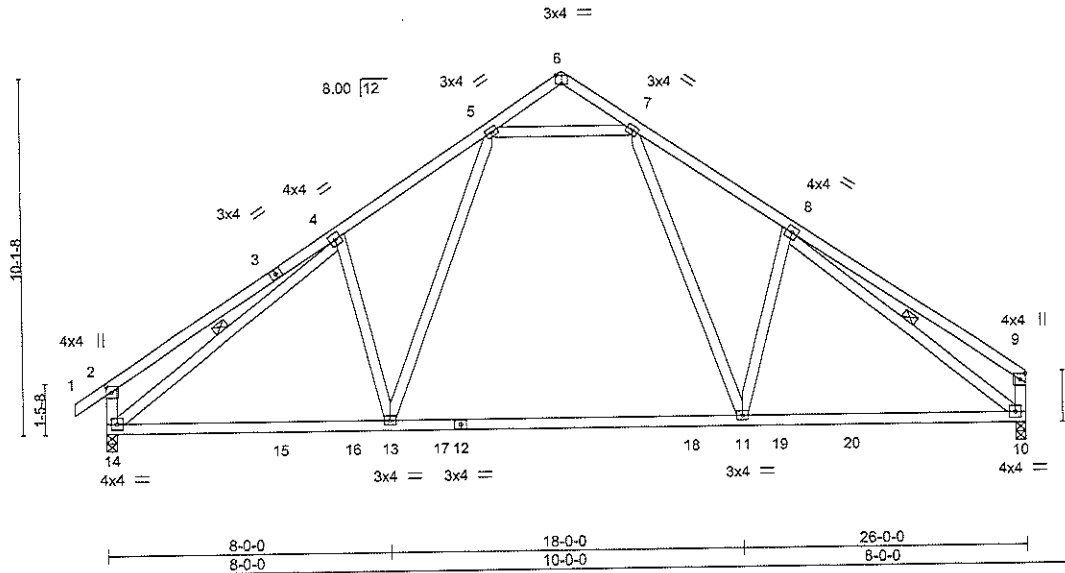

Plate Offsets (X,Y)--	[2:0-2-0,0-1-12], [6:0-2-0,Edge]							
LOADING (psf)	SPACING- 2-0-0	CSI.	DEFL.	in (loc)	l/defl	L/d	PLATES	GRIP
TCLL 20.0	Plate Grip DOL 1.15	TC 0.61	Vert(LL) -0.39	11-13	>798	240	MT20	244/190
TCDL 10.0	Lumber DOL 1.15	BC 0.76	Vert(CT) -0.56	11-13	>551	180		
BCLL 0.0 *	Rep Stress Incr YES	WB 0.46	Horz(CT) 0.03	10	n/a	n/a		
BCDL 10.0	Code IRC2015/TPI2014	Matrix-MS					Weight: 162 lb	FT = 20%

LUMBER-
TOP CHORD 2x4 SP No.2
BOT CHORD 2x4 SP No.1
WEBS 2x4 SP No.3

BRACING-
TOP CHORD Structural wood sheathing directly applied or 4-9-9 oc purlins, except end verticals.
BOT CHORD Rigid ceiling directly applied or 10-0-0 oc bracing.
WEBS 1 Row at midpt 4-14, 8-10

REACTIONS. (size) 14=0-3-8, 10=0-3-8
Max Horz 14=268(LC 9)
Max Uplift 14=-126(LC 12), 10=-105(LC 13)
Max Grav 14=1166(LC 20), 10=1106(LC 21)

FORCES. (lb) - Max. Comp./Max. Ten. - All forces 250 (lb) or less except when shown.
TOP CHORD 2-4=-371/232, 4-5=-1320/333, 7-8=-1329/336, 8-9=-291/175, 2-14=-394/223, 9-10=-292/156
BOT CHORD 13-14=-144/1184, 11-13=-37/920, 10-11=-123/1053
WEBS 7-11=-148/619, 8-11=-269/279, 5-13=-145/607, 4-13=-257/277, 4-14=-1203/32, 8-10=-1250/97, 5-7=-795/288

- NOTES-**
- Unbalanced roof live loads have been considered for this design.
 - Wind: ASCE 7-10; Vult=130mph (3-second gust) Vasd=103mph; TCDL=6.0psf; BCDL=6.0psf; h=30ft; Cat. II; Exp B; Enclosed; MWFRS (envelope) gable end zone and C-C Exterior(2) zone; cantilever left and right exposed; end vertical left and right exposed; C-C for members and forces & MWFRS for reactions shown; Lumber DOL=1.60 plate grip DOL=1.60
 - This truss has been designed for a 10.0 psf bottom chord live load nonconcurrent with any other live loads.
 - * This truss has been designed for a live load of 20.0psf on the bottom chord in all areas where a rectangle 3-6-0 tall by 2-0-0 wide will fit between the bottom chord and any other members, with BCDL = 10.0psf.
 - One H2.5A Simpson Strong-Tie connectors recommended to connect truss to bearing walls due to UPLIFT at jt(s) 14 and 10. This connection is for uplift only and does not consider lateral forces.
 - ATTIC SPACE SHOWN IS DESIGNED AS UNINHABITABLE.

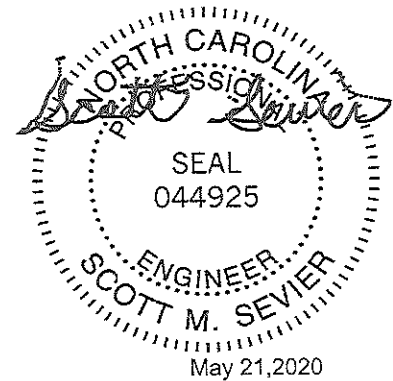

WARNING - Verify design parameters and READ NOTES ON THIS AND INCLUDED MITEK REFERENCE PAGE MH-7473 rev. 10/03/2015 BEFORE USE.
Design valid for use only with Mitek® connectors. This design is based only upon parameters shown, and is for an individual building component, not a truss system. Before use, the building designer must verify the applicability of design parameters and properly incorporate this design into the overall building design. Bracing indicated is to prevent buckling of individual truss web and/or chord members only. Additional temporary and permanent bracing is always required for stability and to prevent collapse with possible personal injury and property damage. For general guidance regarding the fabrication, storage, delivery, erection and bracing of trusses and truss systems, see ANSITPI1 Quality Criteria, DSB-89 and BCSI Building Component Safety Information available from Truss Plate Institute, 218 N. Lee Street, Suite 312, Alexandria, VA 22314.

ENGINEERING BY
TRENCO
A Mitek Affiliate
818 Soundside Road
Edenton, NC 27932

Job 2000367-2000367A	Truss A3A	Truss Type ROOF TRUSS	Qty 1	Ply 1	2307- JRT -DAKOTA II	141377967
-------------------------	--------------	--------------------------	----------	----------	----------------------	-----------

84 Components (Dunn), Dunn, NC - 28334.

8.330 s May 6 2020 MITek Industries, Inc. Wed May 20 13:02:01 2020 Page 1
 ID:ceuvEDckNGn_oUaH?GOU8dzEcIS-DuCbFR8awkmkMIDkdq5modU7w0Lf88QvHfuzEbj

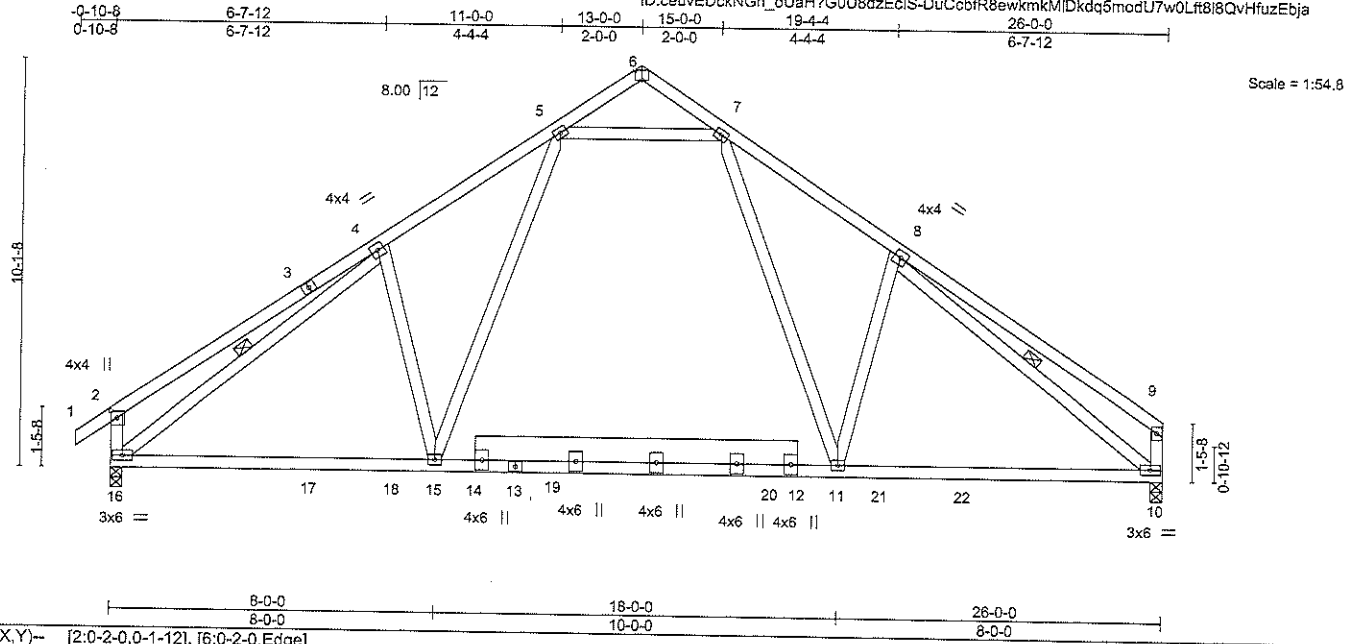

LOADING (psf)	SPACING-	2-0-0	CSI.	DEFL	in (loc)	l/defl	L/d	PLATES	GRIP
TCLL 20.0	Plate Grip DOL	1.15	TC 0.61	Vert(LL)	-0.17 15-16	>999	240	MT20	244/190
TCDL 10.0	Lumber DOL	1.15	BC 0.84	Vert(CT)	-0.24 15-16	>999	180		
BCLL 0.0 *	Rep Stress Incr	YES	WB 0.44	Horz(CT)	0.03 10	n/a	n/a		
BCDL 10.0	Code IRC2015/TP12014		Matrix-MS						
								Weight: 187 lb	FT = 20%

LUMBER-			BRACING-	
TOP CHORD	2x4 SP No.2		TOP CHORD	Structural wood sheathing directly applied or 4-10-6 oc purlins, except end verticals.
BOT CHORD	2x4 SP No.2 *Except		BOT CHORD	Rigid ceiling directly applied or 10-0-0 oc bracing.
WEBS	12-14: 2x8 SP No.2		WEBS	1 Row at midpt 4-16, 8-10
	2x4 SP No.3			

REACTIONS.	(size) 16=0-3-8, 10=0-3-8
	Max Horz 16=268(LC 9)
	Max Uplift 16=-126(LC 12), 10=-105(LC 13)
	Max Grav 16=1159(LC 20), 10=1099(LC 21)

FORCES.	(lb) - Max. Comp./Max. Ten. - All forces 250 (lb) or less except when shown.
TOP CHORD	2-4=-384/226, 4-5=-1282/336, 7-8=-1291/341, 8-9=-319/169, 2-16=-412/219, 9-10=-307/152
BOT CHORD	15-16=-147/1155, 11-15=-40/897, 10-11=-126/1025
WEBS	7-11=-149/596, 8-11=-271/278, 5-15=-146/583, 4-15=-260/275, 4-16=-1133/44, 8-10=-1179/109, 5-7=-772/291

- NOTES-**
- 1) Unbalanced roof live loads have been considered for this design.
 - 2) Wind: ASCE 7-10; Vuit=130mph (3-second gust) Vasd=103mph; TCDL=6.0psf; BCDL=6.0psf; h=30ft; Cat. II; Exp B; Enclosed; MWFRS (envelope) gable end zone and C-C Exterior(2) zone; cantilever left and right exposed; end vertical left and right exposed; C-C for members and forces & MWFRS for reactions shown; Lumber DOL=1.60 plate grip DOL=1.60
 - 3) All plates are 3x4 MT20 unless otherwise indicated.
 - 4) This truss has been designed for a 10.0 psf bottom chord live load nonconcurrent with any other live loads.
 - 5) * This truss has been designed for a live load of 20.0psf on the bottom chord in all areas where a rectangle 3-6-0 tall by 2-0-0 wide will fit between the bottom chord and any other members, with BCDL = 10.0psf.
 - 6) One H2.5A Simpson Strong-Tie connectors recommended to connect truss to bearing walls due to UPLIFT at j(s) 16 and 10. This connection is for uplift only and does not consider lateral forces.
 - 7) ATTIC SPACE SHOWN IS DESIGNED AS UNINHABITABLE.

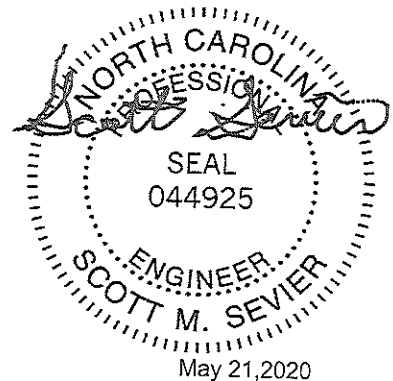

WARNING - Verify design parameters and READ NOTES ON THIS AND INCLUDED MITEK REFERENCE PAGE MIH-7473 rev. 10/03/2015 BEFORE USE.
 Design valid for use only with MITek® connectors. This design is based only upon parameters shown, and is for an individual building component, not a truss system. Before use, the building designer must verify the applicability of design parameters and properly incorporate this design into the overall building design. Bracing indicated is to prevent buckling of individual truss web and/or chord members only. Additional temporary and permanent bracing is always required for stability and to prevent collapse with possible personal injury and property damage. For general guidance regarding the fabrication, storage, delivery, erection and bracing of trusses and truss systems, see ANSUTPH Quality Criteria, DSB-89 and BCSI Building Component Safety Information available from Truss Plate Institute, 218 N. Lee Street, Suite 312, Alexandria, VA 22314.

ENGINEERING BY
TRENCO
 A MITek Affiliate
 818 Soundside Road
 Edenton, NC 27932

Job 2000367-2000367A	Truss A4	Truss Type ROOF TRUSS	Qty 5	Ply 1	2307- JRT -DAKOTA II	141377988
-------------------------	-------------	--------------------------	----------	----------	----------------------	-----------

84 Components (Dunn), Dunn, NC - 28334, 8.330 s May 6 2020 MiTek Industries, Inc. Wed May 20 13:02:02 2020 Page 1
 ID:ceuvEDckNGn_oUaH?G0U8dzEclS=i4l_o?SmPEscMWKPKMKI?AfcKNJOKquM4eqBKzEbjZ

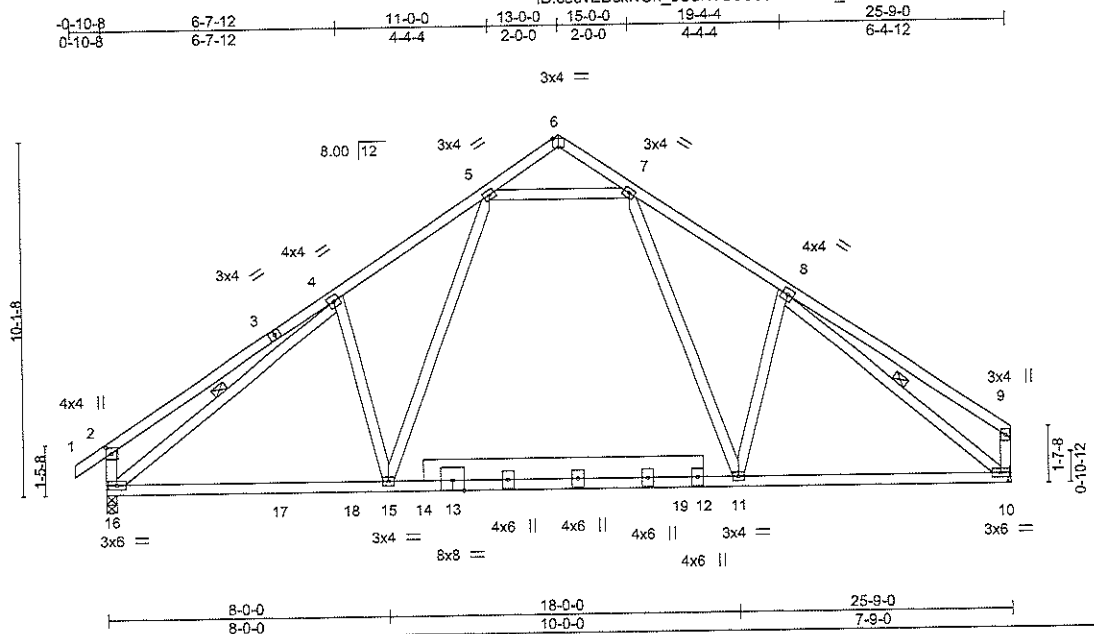

Scale = 1:63.1

Plate Offsets (X,Y)--	[2:0-2-0,0-1-12], [6:0-2-0,Edge]							
LOADING (psf)	SPACING- 2-0-0	CSI.	DEFL.	in (loc)	l/defl	L/d	PLATES	GRIP
TCLL 20.0	Plate Grip DOL 1.15	TC 0.63	Vert(LL) -0.17	15-16	>999	240	MT20	244/190
TCDL 10.0	Lumber DOL 1.15	BC 0.79	Vert(CT) -0.26	15-16	>999	180		
BCLL 0.0 *	Rep Stress Incr YES	WB 0.41	Horz(CT) 0.03	10	n/a	n/a		
BCDL 10.0	Code IRC2015/TPI2014	Matrix-MS					Weight: 186 lb	FT = 20%

LUMBER-		BRACING-	
TOP CHORD	2x4 SP No.2	TOP CHORD	Structural wood sheathing directly applied or 4-9-10 oc purlins, except end verticals.
BOT CHORD	2x4 SP No.2 *Except* 12-14: 2x8 SP No.2	BOT CHORD	Rigid ceiling directly applied or 10-0-0 oc bracing.
WEBS	2x4 SP No.3	WEBS	1 Row at midpt 4-16, 8-10

REACTIONS. (size) 16=0-3-8, 10=Mechanical
 Max Horz 16=270(LC 9)
 Max Uplift 16=-125(LC 12), 10=-103(LC 13)
 Max Grav 16=1132(LC 20), 10=1040(LC 21)

FORCES. (lb) - Max. Comp./Max. Ten. - All forces 250 (lb) or less except when shown.
 TOP CHORD 2-4=-381/226, 4-5=-1247/335, 7-8=-1193/334, 8-9=-265/160, 2-16=-408/219, 9-10=-273/144
 BOT CHORD 15-16=-147/1125, 11-15=-46/856, 10-11=-127/943
 WEBS 4-15=-264/275, 5-15=-145/599, 7-11=-142/499, 8-11=-239/269, 4-16=-1095/41, 8-10=-1140/119, 5-7=-757/290

- NOTES-**
- Unbalanced roof live loads have been considered for this design.
 - Wind: ASCE 7-10; Vuit=130mph (3-second gust) Vasd=103mph; TCDL=6.0psf; BCDL=6.0psf; h=30ft; Cat. II; Exp B; Enclosed; MWFRS (envelope) gable end zone and C-C Exterior(2) zone; cantilever left and right exposed; end vertical left and right exposed; C-C for members and forces & MWFRS for reactions shown; Lumber DOL=1.60 plate grip DOL=1.60
 - This truss has been designed for a 10.0 psf bottom chord live load nonconcurrent with any other live loads.
 - * This truss has been designed for a live load of 20.0psf on the bottom chord in all areas where a rectangle 3-6-0 tall by 2-0-0 wide will fit between the bottom chord and any other members, with BCDL = 10.0psf.
 - Refer to girder(s) for truss to truss connections.
 - Provide mechanical connection (by others) of truss to bearing plate capable of withstanding 100 lb uplift at joint(s) except (it=lb) 10=103.
 - One H2.5A Simpson Strong-Tie connectors recommended to connect truss to bearing walls due to UPLIFT at jt(s) 16. This connection is for uplift only and does not consider lateral forces.
 - ATTIC SPACE SHOWN IS DESIGNED AS UNINHABITABLE.

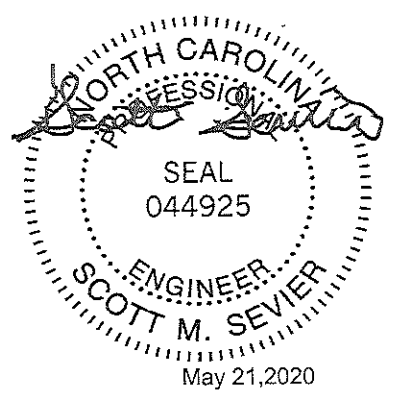

<p>WARNING - Verify design parameters and READ NOTES ON THIS AND INCLUDED MITEK REFERENCE PAGE MII-7473 rev. 10/03/2015 BEFORE USE.</p> <p>Design valid for use only with MiTek® connectors. This design is based only upon parameters shown, and is for an individual building component, not a truss system. Before use, the building designer must verify the applicability of design parameters and properly incorporate this design into the overall building design. Bracing indicated is to prevent buckling of individual truss web and/or chord members only. Additional temporary and permanent bracing is always required for stability and to prevent collapse with possible personal injury and property damage. For general guidance regarding the fabrication, storage, delivery, erection and bracing of trusses and truss systems, see ANSITP11 Quality Criteria, DSB-89 and BCSI Building Component Safety Information available from Truss Plate Institute, 218 N. Lee Street, Suite 312, Alexandria, VA 22314.</p>	<p>ENGINEERING BY TRENCO A MiTek Affiliate</p> <p>818 Soundside Road Edenton, NC 27932</p>
---	--

Job	Truss	Truss Type	Qty	Ply	2307- JRT -DAKOTA II	I41377989
2000367-2000367A	A4E	Common Supported Gable	1	1		

84 Components (Dunn), Dunn, NC - 28334,

8,330 s May 6 2020 MiTek Industries, Inc. Wed May 20 13:02:03 2020 Page 1
 ID:ceuvEDckNGn_oUaH?G0U8dzEciS-AGJM?LTOAY_T_gvbs2zrDjuoktX7rD2bkONkmzEbjY

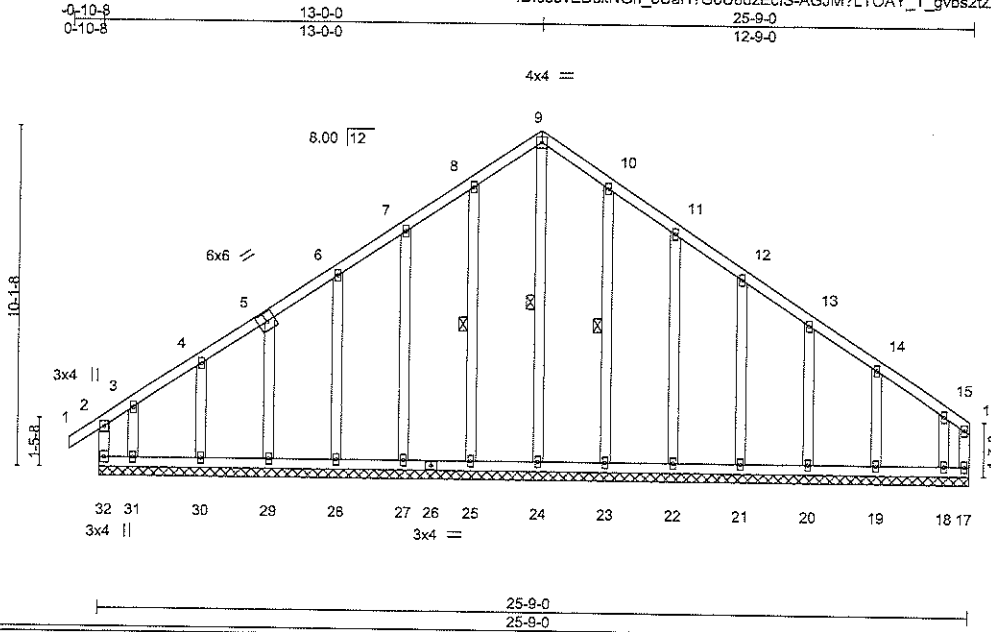

LOADING (psf)	SPACING-	2-0-0	CSI.	DEFL.	in (loc)	l/defl	L/d	PLATES	GRIP
TCLL 20.0	Plate Grip DOL	1.15	TC 0.28	Vert(LL)	-0.00	1	n/r	120	244/190
TCDL 10.0	Lumber DOL	1.15	BC 0.15	Vert(CT)	-0.00	1	n/r	90	
BCLL 0.0	Rep Stress Incr	YES	WB 0.14	Horz(CT)	-0.00	17	n/a	n/a	
BCDL 10.0	Code	IRC2015/TPI2014	Matrix-R						
								Weight: 191 lb	FT = 20%

LUMBER-	BRACING-
TOP CHORD 2x4 SP No.2	TOP CHORD Structural wood sheathing directly applied or 6-0-0 oc purlins, except end verticals.
BOT CHORD 2x4 SP No.2	BOT CHORD Rigid ceiling directly applied or 6-0-0 oc bracing. Except:
WEBS 2x4 SP No.3	10-0-0 oc bracing: 31-32,30-31,29-30.
OTHERS 2x4 SP No.3	WEBS 1 Row at midpt 9-24, 8-25, 10-23

REACTIONS. All bearings 25-9-0.
 (lb) - Max Horz 32=270(LC 9)
 Max Uplift All uplift 100 lb or less at joint(s) 25, 27, 28, 29, 30, 23, 22, 21, 20, 19 except 32=-281(LC 8), 17=-302(LC 11), 31=-282(LC 9), 18=-268(LC 8)
 Max Grav All reactions 250 lb or less at joint(s) 25, 27, 28, 29, 30, 23, 22, 21, 20, 19 except 32=335(LC 9), 17=306(LC 8), 24=270(LC 13), 31=332(LC 10), 18=349(LC 11)

FORCES. (lb) - Max. Comp./Max. Ten. - All forces 250 (lb) or less except when shown.
 TOP CHORD 7-8=-221/274, 8-9=-265/324, 9-10=-265/324, 10-11=-222/274
 WEBS 9-24=-291/175

- NOTES-**
- 1) Unbalanced roof live loads have been considered for this design.
 - 2) Wind: ASCE 7-10; Vult=130mph (3-second gust) Vasd=103mph; TCCL=6.0psf; BCDL=6.0psf; h=30ft; Cat. II; Exp B; Enclosed; MWFRS (envelope) gable end zone and C-C Exterior(2) zone; cantilever left and right exposed; end vertical left and right exposed; C-C for members and forces & MWFRS for reactions shown; Lumber DOL=1.60 plate grip DOL=1.60
 - 3) Truss designed for wind loads in the plane of the truss only. For studs exposed to wind (normal to the face), see Standard Industry Gable End Details as applicable, or consult qualified building designer as per ANSI/TPI 1.
 - 4) All plates are 2x4 MT20 unless otherwise indicated.
 - 5) Gable requires continuous bottom chord bearing.
 - 6) Truss to be fully sheathed from one face or securely braced against lateral movement (i.e. diagonal web).
 - 7) Gable studs spaced at 2-0-0 oc.
 - 8) This truss has been designed for a 10.0 psf bottom chord live load nonconcurrent with any other live loads.
 - 9) * This truss has been designed for a live load of 20.0psf on the bottom chord in all areas where a rectangle 3-6-0 tall by 2-0-0 wide will fit between the bottom chord and any other members.

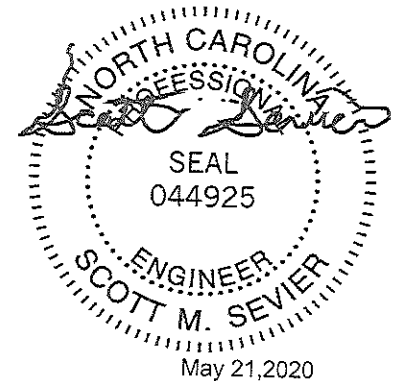

WARNING - Verify design parameters and READ NOTES ON THIS AND INCLUDED MITEK REFERENCE PAGE MII-7473 rev. 10/03/2015 BEFORE USE.

Design valid for use only with MiTek® connectors. This design is based only upon parameters shown, and is for an individual building component, not a truss system. Before use, the building designer must verify the applicability of design parameters and properly incorporate this design into the overall building design. Bracing indicated is to prevent buckling of individual truss web and/or chord members only. Additional temporary and permanent bracing is always required for stability and to prevent collapse with possible personal injury and property damage. For general guidance regarding the fabrication, storage, delivery, erection and bracing of trusses and truss systems, see ANSITPI® Quality Criteria, DSB-89 and BCSI Building Component Safety Information available from Truss Plate Institute, 218 N. Lee Street, Suite 312, Alexandria, VA 22314.



818 Soundside Road
 Edenton, NC 27932

Job 2000367-2000367A	Truss B1	Truss Type Roof Special	Qty 1	Ply 1	2307-JRT -DAKOTA II	141377992
-------------------------	-------------	----------------------------	----------	----------	---------------------	-----------

B4 Components (Dunn), Dunn, NC - 28334.

8,330 s May 6 2020 MiTek Industries, Inc. Wed May 20 13:02:08 2020 Page 1
ID:ceuvEDckNGn_oUaH7G0U8dzEclS-WE7F32XX?4cm4RnZfbTKYQmOIR4c65ni058P_zEbjT

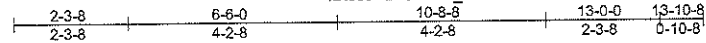

Scale = 1:44.6

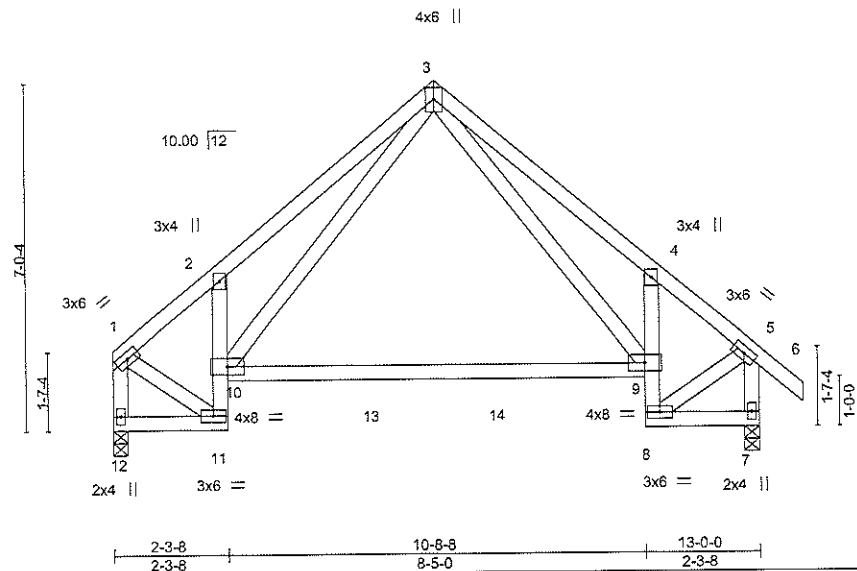

LOADING (psf)	SPACING-	2-0-0	CSI.	DEFL.	in (loc)	l/defl	L/d	PLATES	GRIP
TCLL 20.0	Plate Grip DOL	1.15	TC 0.23	Vert(LL)	-0.20 9-10	>762	240	MT20	244/190
TCDL 10.0	Lumber DOL	1.15	BC 0.76	Vert(CT)	-0.42 9-10	>362	180		
BCLL 0.0 *	Rep Stress Incr	YES	WB 0.17	Horz(CT)	0.11 7	n/a	n/a		
BCDL 10.0	Code IRC2015/TPI2014		Matrix-MS					Weight: 85 lb	FT = 20%

LUMBER-	BRACING-
TOP CHORD 2x4 SP No.2	TOP CHORD Structural wood sheathing directly applied or 6-0-0 oc purlins, except end verticals.
BOT CHORD 2x4 SP No.2	BOT CHORD Rigid ceiling directly applied or 6-0-0 oc bracing.
WEBS 2x4 SP No.3	

REACTIONS. (size) 12=0-3-8, 7=0-3-8
 Max Horz 12=-195(LC 8)
 Max Uplift 12=-42(LC 12), 7=-61(LC 13)
 Max Grav 12=506(LC 1), 7=572(LC 1)

FORCES. (lb) - Max. Comp./Max. Ten. - All forces 250 (lb) or less except when shown.
 TOP CHORD 1-2=-449/110, 2-3=-823/271, 3-4=-730/257, 4-5=-442/111, 1-12=-538/102, 5-7=-601/151
 BOT CHORD 2-10=-375/218, 9-10=-31/338, 4-9=-357/202
 WEBS 3-9=-153/441, 3-10=-172/523, 1-11=-79/358, 5-8=-48/353

- NOTES-**
- 1) Unbalanced roof live loads have been considered for this design.
 - 2) Wind: ASCE 7-10; Vult=130mph (3-second gust) Vasd=103mph; TCCL=6.0psf; BCDL=6.0psf; h=30ft; Cat. II; Exp B; Enclosed; MWFRS (envelope) gable end zone and C-C Exterior(2) zone; cantilever left and right exposed ; end vertical left and right exposed; C-C for members and forces & MWFRS for reactions shown; Lumber DOL=1.60 plate grip DOL=1.60
 - 3) This truss has been designed for a 10.0 psf bottom chord live load nonconcurrent with any other live loads.
 - 4) * This truss has been designed for a live load of 20.0psf on the bottom chord in all areas where a rectangle 3-6-0 tall by 2-0-0 wide will fit between the bottom chord and any other members, with BCDL = 10.0psf.
 - 5) One H2.5A Simpson Strong-Tie connectors recommended to connect truss to bearing walls due to UPLIFT at jt(s) 12 and 7. This connection is for uplift only and does not consider lateral forces.

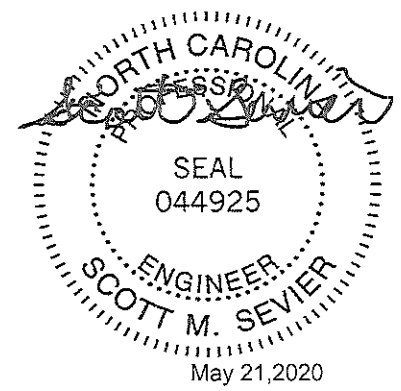

May 21, 2020

<p>WARNING - Verify design parameters and READ NOTES ON THIS AND INCLUDED MITEK REFERENCE PAGE MII-7473 rev. 10/03/2015 BEFORE USE. Design valid for use only with MiTek® connectors. This design is based only upon parameters shown, and is for an individual building component, not a truss system. Before use, the building designer must verify the applicability of design parameters and properly incorporate this design into the overall building design. Bracing indicated is to prevent buckling of individual truss web and/or chord members only. Additional temporary and permanent bracing is always required for stability and to prevent collapse with possible personal injury and property damage. For general guidance regarding the fabrication, storage, delivery, erection and bracing of trusses and truss systems, see ANSITP11 Quality Criteria, DSB-89 and BCSI Building Component Safety Information available from Truss Plate Institute, 218 N. Lee Street, Suite 312, Alexandria, VA 22314.</p>	<p>ENGINEERING BY TRENCO A MiTek Affiliate 818 Soundside Road Edenton, NC 27932</p>
---	---

Job 2000367-2000367A	Truss BE	Truss Type Common Supported Gable	Qty 1	Ply 1	2307-JRT -DAKOTA II	I41377993
-------------------------	-------------	--------------------------------------	----------	----------	---------------------	-----------

84 Components (Dunn), Dunn, NC - 28334,

8.330 s May 6 2020 MiTek Industries, Inc. Wed May 20 13:02:09 2020 Page 1

ID:ceuvEDckNGn_oUaH7G0U3dzEciS-QgdGOY9mNkdibMIC1_z4UzzY9yXXaKw_grixQzEbjs

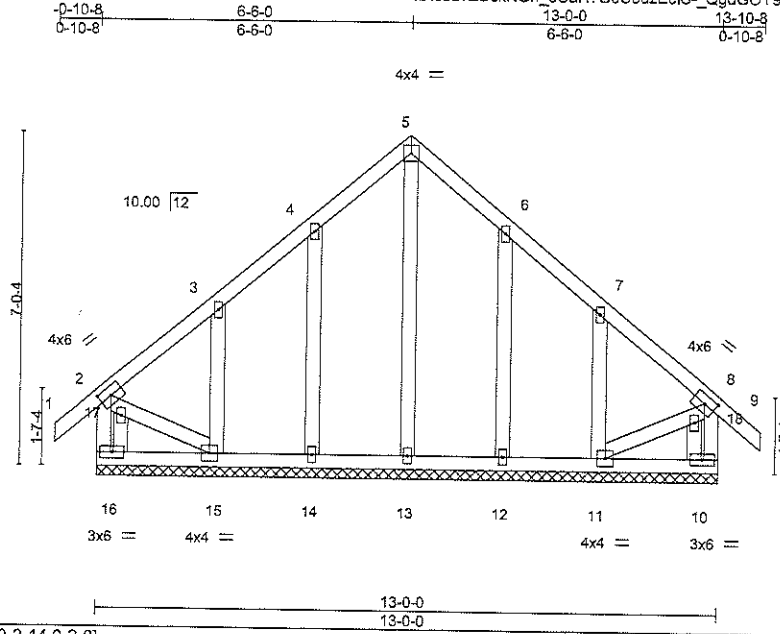

Scale = 1:46.3

Plate Offsets (X,Y)-- [2:0-2-14,0-2-0], [8:0-2-14,0-2-0]

LOADING (psf)	SPACING-	2-0-0	CSI.	DEFL.	in (loc)	l/defl	L/d	PLATES	GRIP
TCLL 20.0	Plate Grip DOL	1.15	TC 0.07	Vert(LL)	-0.00	9	n/r	MT20	244/190
TCDL 10.0	Lumber DOL	1.15	BC 0.05	Vert(CT)	-0.00	9	n/r		
BCLL 0.0 *	Rep Stress Incr	YES	WB 0.10	Horz(CT)	0.00	11	n/a		
BCDL 10.0	Code IRC2015/TP12014		Matrix-S						
								Weight: 95 lb	FT = 20%

LUMBER-
 TOP CHORD 2x4 SP No.2
 BOT CHORD 2x4 SP No.2
 WEBS 2x4 SP No.3
 OTHERS 2x4 SP No.3

BRACING-
 TOP CHORD Structural wood sheathing directly applied or 6-0-0 oc purlins, except end verticals.
 BOT CHORD Rigid ceiling directly applied or 6-0-0 oc bracing.

REACTIONS. All bearings 13-0-0.
 (lb) - Max Horz 16=-202(LC 10)
 Max Uplift All uplift 100 lb or less at joint(s) 16, 10, 14, 12 except 15=-169(LC 12), 11=-165(LC 13)
 Max Grav All reactions 250 lb or less at joint(s) 16, 10, 13, 14, 15, 12, 11

FORCES. (lb) - Max. Comp./Max. Ten. - All forces 250 (lb) or less except when shown.

NOTES-

- 1) Unbalanced roof live loads have been considered for this design.
- 2) Wind: ASCE 7-10; Vult=130mph (3-second gust) Vasd=103mph; TCDL=6.0psf; BCDL=6.0psf; h=30ft; Cat. II; Exp B; Enclosed; MWFRS (envelope) gable end zone and C-C Exterior(2) zone; cantilever left and right exposed; end vertical left and right exposed; C-C for members and forces & MWFRS for reactions shown; Lumber DOL=1.60 plate grip DOL=1.60
- 3) Truss designed for wind loads in the plane of the truss only. For studs exposed to wind (normal to the face), see Standard Industry Gable End Details as applicable, or consult qualified building designer as per ANSI/TP1 1.
- 4) All plates are 2x4 MT20 unless otherwise indicated.
- 5) Gable requires continuous bottom chord bearing.
- 6) Truss to be fully sheathed from one face or securely braced against lateral movement (i.e. diagonal web).
- 7) Gable studs spaced at 2-0-0 oc.
- 8) This truss has been designed for a 10.0 psf bottom chord live load nonconcurrent with any other live loads.
- 9) * This truss has been designed for a live load of 20.0psf on the bottom chord in all areas where a rectangle 3-6-0 tall by 2-0-0 wide will fit between the bottom chord and any other members.

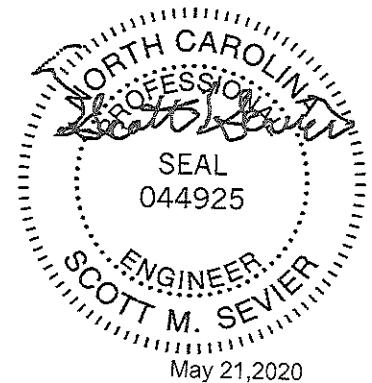

WARNING - Verify design parameters and READ NOTES ON THIS AND INCLUDED MITEK REFERENCE PAGE MI-7473 rev. 10/03/2015 BEFORE USE.

Design valid for use only with MiTek® connectors. This design is based only upon parameters shown, and is for an individual building component, not a truss system. Before use, the building designer must verify the applicability of design parameters and properly incorporate this design into the overall building design. Bracing indicated is to prevent buckling of individual truss web and/or chord members only. Additional temporary and permanent bracing is always required for stability and to prevent collapse with possible personal injury and property damage. For general guidance regarding the fabrication, storage, delivery, erection and bracing of trusses and truss systems, see ANSITP11 Quality Criteria, DSB-89 and BCSI Building Component Safety Information available from Truss Plate Institute, 218 N. Lee Street, Suite 312, Alexandria, VA 22314.

ENGINEERING BY
TRENCO
 A MiTek Alliance

818 Soundside Road
 Edenton, NC 27932

Job	Truss	Truss Type	Qty	Ply	2307- JRT -DAKOTA II	14137994
2000367-2000367A	BGR	Roof Special Girder	1	2	Job Reference (optional)	

84 Components (Dunn), Dunn, NC - 28334,

8.330 s May 6 2020 MiTek Industries, Inc. Wed May 20 13:02:12 2020 Page 1

ID:ceuvEDckNGn_oUah?G0U8dzEcIS-P?MmuQa22i7CZ35KuRXgi6bRNmNkm5Mge3MYzEbJP

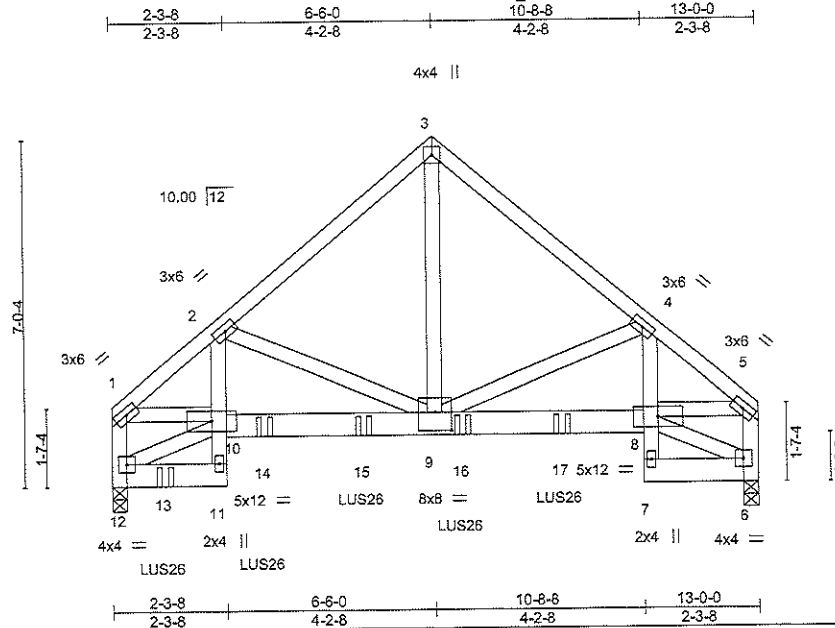

Scale = 1:44.6

Plate Offsets (X,Y) - [9;0-4-0,0-4-8]

LOADING (psf)	SPACING-	2-0-0	CSI.	DEFL.	in	(loc)	l/defl	L/d	PLATES	GRIP
TCLL 20.0	Plate Grip DOL	1.15	TC 0.29	Vert(LL)	-0.04	9-10	>999	240	MT20	244/190
TCDL 10.0	Lumber DOL	1.15	BC 0.87	Vert(CT)	-0.09	9-10	>999	180		
BCLL 0.0 *	Rep Stress Incr	NO	WB 0.74	Horz(CT)	0.06	6	n/a	n/a		
BCDL 10.0	Code IRC2015/TP12014		Matrix-MS						Weight: 197 lb	FT = 20%

LUMBER-

TOP CHORD 2x4 SP No.2
 BOT CHORD 2x6 SP No.2 *Except*
 2-11,4-7: 2x4 SP No.3
 WEBS 2x4 SP No.3

BRACING-

TOP CHORD Structural wood sheathing directly applied or 6-0-0 oc purlins, except end verticals.
 BOT CHORD Rigid ceiling directly applied or 10-0-0 oc bracing.

REACTIONS.

(size) 12=0-3-8, 6=0-3-8
 Max Horz 12=178(LC 11)
 Max Uplift 12=413(LC 12), 6=362(LC 13)
 Max Grav 12=3735(LC 1), 6=3288(LC 1)

FORCES. (lb) - Max. Comp./Max. Ten. - All forces 250 (lb) or less except when shown.

TOP CHORD 1-2=-4156/562, 2-3=-3092/450, 3-4=-3092/450, 4-5=-4254/553, 1-12=-3176/425,
 5-6=-3255/423
 BOT CHORD 10-11=-44/458, 2-10=-171/1009, 9-10=-468/3281, 8-9=-453/3338, 4-8=-154/1095
 WEBS 3-9=-449/3582, 4-9=-1141/267, 2-9=-1078/274, 1-10=-380/3096, 5-8=-414/3223

NOTES-

- 2-ply truss to be connected together with 10d (0.120"x3") nails as follows:
 Top chords connected as follows: 2x4 - 1 row at 0-9-0 oc.
 Bottom chords connected as follows: 2x6 - 2 rows staggered at 0-6-0 oc, 2x4 - 1 row at 0-7-0 oc.
 Webs connected as follows: 2x4 - 1 row at 0-9-0 oc.
- All loads are considered equally applied to all plies, except if noted as front (F) or back (B) face in the LOAD CASE(S) section. Ply to ply connections have been provided to distribute only loads noted as (F) or (B), unless otherwise indicated.
- Unbalanced roof live loads have been considered for this design.
- Wind: ASCE 7-10; Vult=130mph (3-second gust) Vasd=103mph; TC DL=6.0psf; BC DL=6.0psf; h=30ft; Cat. II; Exp B; Enclosed; MWFRS (envelope) gable end zone and C-C Exterior(2) zone; cantilever left and right exposed; end vertical left and right exposed; C-C for members and forces & MWFRS for reactions shown; Lumber DOL=1.60 plate grip DOL=1.60
- This truss has been designed for a 10.0 psf bottom chord live load nonconcurrent with any other live loads.
- * This truss has been designed for a live load of 20.0psf on the bottom chord in all areas where a rectangle 3-6-0 tall by 2-0-0 wide will fit between the bottom chord and any other members.
- Bearing at joint(s) 12, 6 considers parallel to grain value using ANSI/TP1 1 angle to grain formula. Building designer should verify capacity of bearing surface.
- One H2.5A Simpson Strong-Tie connectors recommended to connect truss to bearing walls due to UPLIFT at jt(s) 12 and 6. This connection is for uplift only and does not consider lateral forces.
- Use Simpson Strong-Tie LUS26 (4-10d Girder, 4-10d Truss) or equivalent spaced at 2-0-0 oc max. starting at 1-0-12 from the left end to 9-0-12 to connect truss(es) to back face of bottom chord.
- Fill all nail holes where hanger is in contact with lumber.
- Hanger(s) or other connection device(s) shall be provided sufficient to support concentrated load(s) 997 lb down and 123 lb up at 10-10-4 on bottom chord. The design/selection of such connection device(s) is the responsibility of others.

LOAD CASE(S) Standard

Continued on page 2

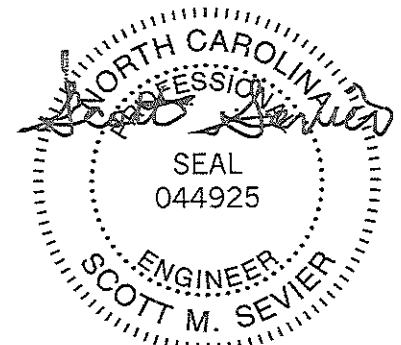

May 21, 2020

WARNING - Verify design parameters and READ NOTES ON THIS AND INCLUDED MITEK REFERENCE PAGE MH-7473 rev. 10/03/2015 BEFORE USE.

Design valid for use only with MiTek® connectors. This design is based only upon parameters shown, and is for an individual building component, not a truss system. Before use, the building designer must verify the applicability of design parameters and properly incorporate this design into the overall building design. Bracing indicated is to prevent buckling of individual truss web and/or chord members only. Additional temporary and permanent bracing is always required for stability and to prevent collapse with possible personal injury and property damage. For general guidance regarding the fabrication, storage, delivery, erection and bracing of trusses and truss systems, see ANSI/TP1 Quality Criteria, DSB-89 and BCSI Building Component Safety Information available from Truss Plate Institute, 218 N. Lee Street, Suite 312, Alexandria, VA 22314.

ENGINEERING BY
TRENCO
 A MITEK AFFILIATE

818 Soundside Road
 Edenton, NC 27932

Job 2000367-2000367A	Truss BGR	Truss Type Roof Special Girder	Qty 1	Ply 2	2307- JRT -DAKOTA II Job Reference (optional)	41377994
-------------------------	--------------	-----------------------------------	----------	----------	--	----------

84 Components (Dunn), Dunn, NC - 28334,

8.330 s May 6 2020 MiTek Industries, Inc. Wed May 20 13:02:12 2020 Page 2
ID:ceuvEDckNGn_oUaH?G0U8dzEclS-P?MmuQa22I7CZ35KuRXgi6bRNMmNkm5Mge3MYzEbjP

LOAD CASE(S) Standard

1) Dead + Roof Live (balanced): Lumber Increase=1.15, Plate Increase=1.15

Uniform Loads (plf)

Vert: 1-3=-60, 3-5=-60, 11-12=-20, 8-10=-20, 6-7=-20

Concentrated Loads (lb)

Vert: 8=-997(B) 13=-998(B) 14=-1003(B) 15=-1003(B) 16=-1003(B) 17=-1003(B)

WARNING - Verify design parameters and READ NOTES ON THIS AND INCLUDED MITEK REFERENCE PAGE MII-7473 rev. 10/03/2015 BEFORE USE.

Design valid for use only with MiTek® connectors. This design is based only upon parameters shown, and is for an individual building component, not a truss system. Before use, the building designer must verify the applicability of design parameters and properly incorporate this design into the overall building design. Bracing indicated is to prevent buckling of individual truss web and/or chord members only. Additional temporary and permanent bracing is always required for stability and to prevent collapse with possible personal injury and property damage. For general guidance regarding the fabrication, storage, delivery, erection and bracing of trusses and truss systems, see ANSITP11 Quality Criteria, DSB-89 and BCSI Building Component Safety Information available from Truss Plate Institute, 218 N. Lee Street, Suite 312, Alexandria, VA 22314.

ENGINEERING BY
TRENCO
A MiTek Affiliate

818 Soundside Road
Edenton, NC 27932

Job 2000367-2000367A	Truss C	Truss Type Common	Qty 2	Ply 1	2307- JRT -DAKOTA II Job Reference (optional)	I41377995
-------------------------	------------	----------------------	----------	----------	--	-----------

84 Components (Dunn), Dunn, NC - 28334,

8.330 s May 6 2020 MITek Industries, Inc. Wed May 20 13:02:13 2020 Page 1

ID:ceuvEDckNGn_oUaH?G0U8dzEcIS-tBw86mbgpcF3ACgWR82vFK7ZtmFITNIWulpv4BzEbjO

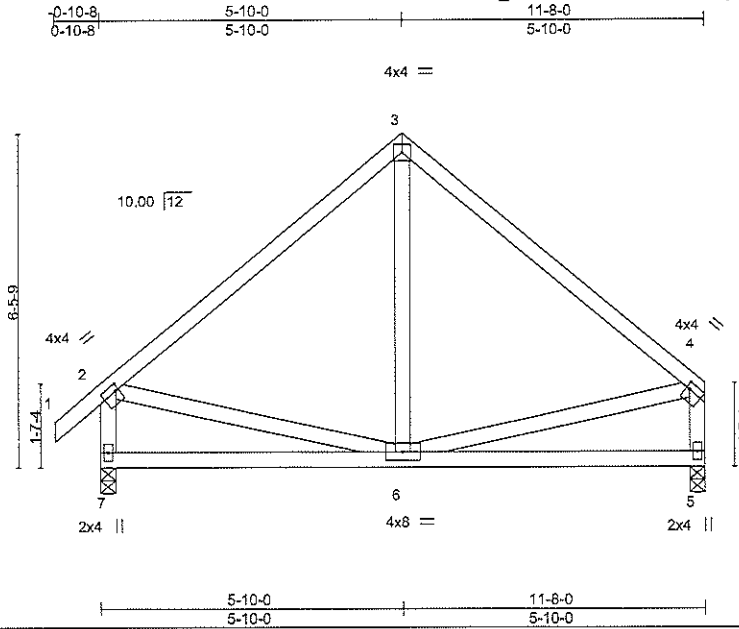

Scale = 1:42.7

Plate Offsets (X,Y)-- [2:0-0-12,0-1-8], [4:0-0-12,0-1-8]

LOADING (psf)	SPACING-	CSI.	DEFL.	in (loc)	l/def	L/d	PLATES	GRIP
TCLL 20.0	2-0-0	TC 0.50	Vert(LL)	-0.02	5-6	>999	MT20	244/190
TCDL 10.0	Plate Grip DOL 1.15	BC 0.28	Vert(CT)	-0.05	5-6	>999		
BCLL 0.0 *	Lumber DOL 1.15	WB 0.08	Horz(CT)	0.00	5	n/a		
BCDL 10.0	Rep Stress Incr YES	Matrix-MS						
	Code IRC2015/TPI2014						Weight: 71 lb	FT = 20%

LUMBER-
 TOP CHORD 2x4 SP No.2
 BOT CHORD 2x4 SP No.2
 WEBS 2x4 SP No.3

BRACING-
 TOP CHORD Structural wood sheathing directly applied or 6-0-0 oc purlins, except end verticals.
 BOT CHORD Rigid ceiling directly applied or 10-0-0 oc bracing.

REACTIONS. (size) 7=0-3-8, 5=0-3-8
 Max Horz 7=181(LC 9)
 Max Uplift 7=-56(LC 12), 5=-37(LC 13)
 Max Grav 7=519(LC 1), 5=452(LC 1)

FORCES. (lb) - Max. Comp./Max. Ten. - All forces 250 (lb) or less except when shown.
 TOP CHORD 2-3=-422/118, 3-4=-415/112, 2-7=-468/160, 4-5=-401/117

- NOTES-**
- 1) Unbalanced roof live loads have been considered for this design.
 - 2) Wind: ASCE 7-10; Vult=130mph (3-second gust) Vasd=103mph; TCDL=6.0psf; BCDL=6.0psf; h=30ft; Cat. II; Exp B; Enclosed; MWFRS (envelope) gable end zone and C-C Exterior(2) zone; cantilever left and right exposed; end vertical left and right exposed; C-C for members and forces & MWFRS for reactions shown; Lumber DOL=1.60 plate grip DOL=1.60
 - 3) This truss has been designed for a 10.0 psf bottom chord live load nonconcurrent with any other live loads.
 - 4) * This truss has been designed for a live load of 20.0psf on the bottom chord in all areas where a rectangle 3-6-0 tall by 2-0-0 wide will fit between the bottom chord and any other members.
 - 5) One H2.5A Simpson Strong-Tie connectors recommended to connect truss to bearing walls due to UPLIFT at jt(s) 7 and 5. This connection is for uplift only and does not consider lateral forces.

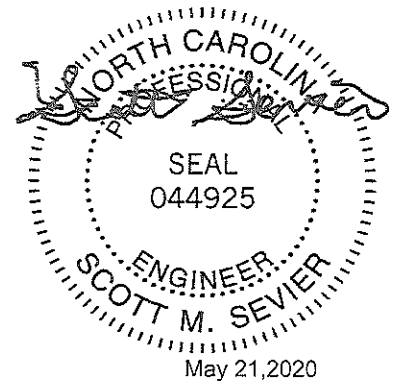

WARNING - Verify design parameters and READ NOTES ON THIS AND INCLUDED MITEK REFERENCE PAGE MH-7473 rev. 10/03/2015 BEFORE USE.

Design valid for use only with MITek® connectors. This design is based only upon parameters shown, and is for an individual building component, not a truss system. Before use, the building designer must verify the applicability of design parameters and properly incorporate this design into the overall building design. Bracing indicated is to prevent buckling of individual truss web and/or chord members only. Additional temporary and permanent bracing is always required for stability and to prevent collapse with possible personal injury and property damage. For general guidance regarding the fabrication, storage, delivery, erection and bracing of trusses and truss systems, see ANSITP1 Quality Criteria, DSB-89 and BCSI Building Component Safety Information available from Truss Plate Institute, 218 N. Lee Street, Suite 312, Alexandria, VA 22314.

ENGINEERING BY
TRENCO
 A MITek Affiliate

818 Soundside Road
 Edenton, NC 27932

Job 2000367-2000367A	Truss CE	Truss Type Common Supported Gable	Qty 1	Ply 1	2307- JRT -DAKOTA II	41377996
-------------------------	-------------	--------------------------------------	----------	----------	----------------------	----------

84 Components (Dunn), Dunn, NC - 28334,

Job Reference (optional)

8.330 s May 6 2020 MITek Industries, Inc. Wed May 20 13:02:14 2020 Page 1
ID:ceuvEDckNGn_oUaH?GOU8dzEcIS-LOUWJ6clawNwoMFI?rZ8nXgqHAfqCqz7yYTcdzEbjN

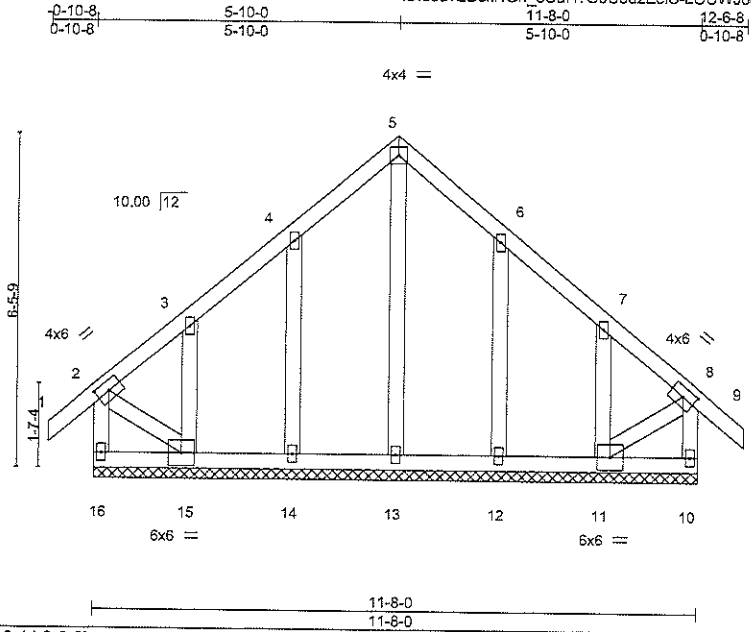

Scale = 1:42.7

Plate Offsets (X,Y)-- [2:0-2-14,0-2-0], [8:0-2-14,0-2-0]

LOADING (psf)	SPACING-	CSI.	DEFL.	PLATES	GRIP
TCLL 20.0	Plate Grip DOL 2-0-0	TC 0.07	in (loc) l/defl L/d	MT20	244/190
TCDL 10.0	Lumber DOL 1.15	BC 0.04	Vert(LL) -0.00 9 n/r 120		
BCLL 0.0 *	Rep Stress Incr YES	WB 0.08	Vert(CT) -0.00 9 n/r 90		
BCDL 10.0	Code IRC2015/TPI2014	Matrix-S	Horz(CT) 0.00 10 n/a n/a		
				Weight: 82 lb	FT = 20%

LUMBER-	BRACING-
TOP CHORD 2x4 SP No.2	TOP CHORD Structural wood sheathing directly applied or 6-0-0 oc purlins, except end verticals.
BOT CHORD 2x4 SP No.2	BOT CHORD Rigid ceiling directly applied or 6-0-0 oc bracing.
WEBS 2x4 SP No.3	
OTHERS 2x4 SP No.3	

REACTIONS. All bearings 11-8-0.
(lb) - Max Horz 16=188(LC 11)
Max Uplift All uplift 100 lb or less at joint(s) 16, 10, 14, 12 except 15=-159(LC 12), 11=-154(LC 13)
Max Grav All reactions 250 lb or less at joint(s) 16, 10, 13, 14, 15, 12, 11

FORCES. (lb) - Max. Comp./Max. Ten. - All forces 250 (lb) or less except when shown.

- NOTES-**
- 1) Unbalanced roof live loads have been considered for this design.
 - 2) Wind: ASCE 7-10; Vult=130mph (3-second gust) Vasd=103mph; TCCL=6.0psf; BCDL=6.0psf; h=30ft; Cat. II; Exp B; Enclosed; MWFRS (envelope) gable end zone and C-C Exterior(2) zone; cantilever left and right exposed; end vertical left and right exposed; C-C for members and forces & MWFRS for reactions shown; Lumber DOL=1.60 plate grip DOL=1.60
 - 3) Truss designed for wind loads in the plane of the truss only. For studs exposed to wind (normal to the face), see Standard Industry Gable End Details as applicable, or consult qualified building designer as per ANSI/TPI 1.
 - 4) All plates are 2x4 MT20 unless otherwise indicated.
 - 5) Gable requires continuous bottom chord bearing.
 - 6) Truss to be fully sheathed from one face or securely braced against lateral movement (i.e. diagonal web).
 - 7) Gable studs spaced at 2-0-0 oc.
 - 8) This truss has been designed for a 10.0 psf bottom chord live load nonconcurrent with any other live loads.
 - 9) * This truss has been designed for a live load of 20.0psf on the bottom chord in all areas where a rectangle 3-6-0 tall by 2-0-0 wide will fit between the bottom chord and any other members.

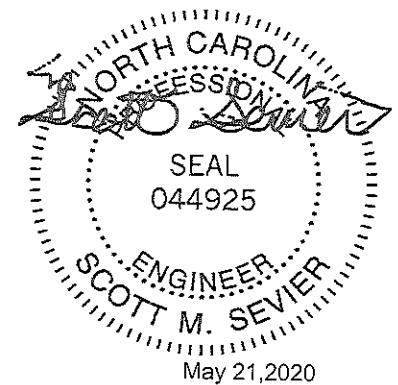

WARNING - Verify design parameters and READ NOTES ON THIS AND INCLUDED MITEK REFERENCE PAGE MII-7473 rev. 10/03/2015 BEFORE USE.

Design valid for use only with MITek® connectors. This design is based only upon parameters shown, and is for an individual building component, not a truss system. Before use, the building designer must verify the applicability of design parameters and properly incorporate this design into the overall building design. Bracing indicated is to prevent buckling of individual truss web and/or chord members only. Additional temporary and permanent bracing is always required for stability and to prevent collapse with possible personal injury and property damage. For general guidance regarding the fabrication, storage, delivery, erection and bracing of trusses and truss systems, see ANSITPH Quality Criteria, DSB-89 and BCST Building Component Safety Information available from Truss Plate Institute, 218 N. Lee Street, Suite 312, Alexandria, VA 22314.

ENGINEERING BY
TRENCO
A MITek Affiliate

818 Soundside Road
Edenton, NC 27932

Job 2000367-2000367A	Truss CGR	Truss Type Common Girder	Qty 1	Ply 2	2307- JRT -DAKOTA II	141377997
-------------------------	--------------	-----------------------------	----------	----------	----------------------	-----------

84 Components (Dunn), Dunn, NC - 28334,

8.330 s May 6 2020 MiTek Industries, Inc. Wed May 20 13:02:16 2020 Page 1

ID:ceuvEDckNGn_oUah?G0U8dzEclS-HmcHkodY6Xdd2gO57Gccsy1?8z89gdkybG1ZnWzEbjL

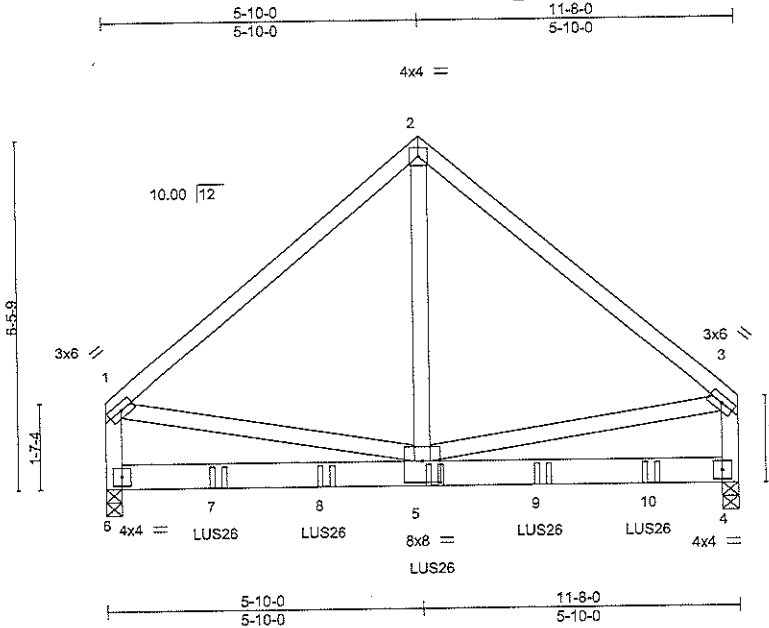

Scale = 1:140.9

Plate Offsets (X,Y)-- [5-0-4-0-0-4-12]

LOADING (psf)	SPACING-	CSL	DEFL.	in (loc)	l/defl	L/d	PLATES	GRIP
TCLL 20.0	2-0-0	TC 0.82	Vert(LL)	-0.05	5-6	>999	MT20	244/190
TCDL 10.0	Plate Grip DOL 1.15	BC 0.88	Vert(CT)	-0.10	5-6	>999		
BCLL 0.0 *	Lumber DOL 1.15	WB 0.57	Horz(CT)	0.00	4	n/a		
BCDL 10.0	Rep Stress Incr NO	Matrix-MS					Weight: 156 lb	FT = 20%
	Code IRC2015/TPI2014							

LUMBER-
 TOP CHORD 2x4 SP No.2
 BOT CHORD 2x6 SP No.2
 WEBS 2x4 SP No.3

BRACING-
 TOP CHORD Structural wood sheathing directly applied or 6-0-0 oc purlins, except end verticals.
 BOT CHORD Rigid ceiling directly applied or 10-0-0 oc bracing.

REACTIONS. (size) 6=0-3-8, 4=0-3-8
 Max Horz 6=-164(LC 31)
 Max Uplift 6=-315(LC 12), 4=-333(LC 13)
 Max Grav 6=2867(LC 1), 4=3028(LC 1)

FORCES. (lb) - Max. Comp./Max. Ten. - All forces 250 (lb) or less except when shown.
 TOP CHORD 1-2=-2517/350, 2-3=-2518/350, 1-6=-2052/302, 3-4=-2050/302
 BOT CHORD 5-6=-211/468, 4-5=-110/387
 WEBS 2-5=-265/2762, 1-5=-198/1516, 3-5=-200/1508

NOTES-

- 2-ply truss to be connected together with 10d (0.120"x3") nails as follows:
 Top chords connected as follows: 2x4 - 1 row at 0-9-0 oc.
 Bottom chords connected as follows: 2x6 - 2 rows staggered at 0-7-0 oc.
 Webs connected as follows: 2x4 - 1 row at 0-9-0 oc.
- All loads are considered equally applied to all plies, except if noted as front (F) or back (B) face in the LOAD CASE(S) section. Ply to ply connections have been provided to distribute only loads noted as (F) or (B), unless otherwise indicated.
- Unbalanced roof live loads have been considered for this design.
- Wind: ASCE 7-10; Vult=130mph (3-second gust) Vasd=103mph; TCDL=6.0psf; BCDL=6.0psf; h=30ft; Cat. II; Exp B; Enclosed; MWFRS (envelope) gable end zone and C-C Exterior(2) zone; cantilever left and right exposed; end vertical left and right exposed; C-C for members and forces & MWFRS for reactions shown; Lumber DOL=1.60 plate grip DOL=1.60
- This truss has been designed for a 10.0 psf bottom chord live load nonconcurrent with any other live loads.
- * This truss has been designed for a live load of 20.0psf on the bottom chord in all areas where a rectangle 3-6-0 tall by 2-0-0 wide will fit between the bottom chord and any other members.
- Bearing at joint(s) 6, 4 considers parallel to grain value using ANSI/TPI 1 angle to grain formula. Building designer should verify capacity of bearing surface.
- One H2.5A Simpson Strong-Tie connectors recommended to connect truss to bearing walls due to UPLIFT at j(s) 6 and 4. This connection is for uplift only and does not consider lateral forces.
- Use Simpson Strong-Tie LUS26 (4-10d Girder, 4-10d Truss) or equivalent spaced at 2-0-0 oc max. starting at 2-0-12 from the left end to 10-0-12 to connect truss(es) to back face of bottom chord.
- Fill all nail holes where hanger is in contact with lumber.

Continued on page 2

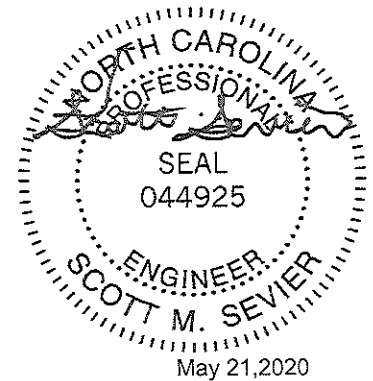

WARNING - Verify design parameters and READ NOTES ON THIS AND INCLUDED MITEK REFERENCE PAGE MII-7473 rev. 10/03/2015 BEFORE USE.
 Design valid for use only with MiTek® connectors. This design is based only upon parameters shown, and is for an individual building component, not a truss system. Before use, the building designer must verify the applicability of design parameters and properly incorporate this design into the overall building design. Bracing indicated is to prevent buckling of individual truss web and/or chord members only. Additional temporary and permanent bracing is always required for stability and to prevent collapse with possible personal injury and property damage. For general guidance regarding the fabrication, storage, delivery, erection and bracing of trusses and truss systems, see ANSI/TPI Quality Criteria, DSB-89 and BCSI Building Component Safety Information available from Truss Plate Institute, 218 N. Lee Street, Suite 312, Alexandria, VA 22314.

ENGINEERING BY
TRENCO
 A MiTek Affiliate
 816 Soundside Road
 Edenton, NC 27932

Job 2000367-2000367A	Truss CGR	Truss Type Common Girder	Qty 1	Ply 2	2307-JRT -DAKOTA II Job Reference (optional)	141377997
-------------------------	--------------	-----------------------------	----------	----------	---	-----------

84 Components (Dunn), Dunn, NC - 28334.

8.330 s May 6 2020 MiTek Industries, Inc. Wed May 20 13:02:16 2020 Page 2
ID:ceuvEDckNGn_cUaH?G0U8dzEclS-HmcHkodY6Xdd2gO57Gccsyf?8z89gdkybG1ZhWzEbjL

LOAD CASE(S) Standard

1) Dead + Roof Live (balanced): Lumber Increase=1.15, Plate Increase=1.15

Uniform Loads (plf)

Vert: 1-2=-60, 2-3=-60, 4-6=-20

Concentrated Loads (lb)

Vert: 5=-997(B) 7=-997(B) 8=-997(B) 9=-997(B) 10=-997(B)

WARNING - Verify design parameters and READ NOTES ON THIS AND INCLUDED MITEK REFERENCE PAGE MII-7473 rev. 10/03/2015 BEFORE USE.

Design valid for use only with MiTek® connectors. This design is based only upon parameters shown, and is for an individual building component, not a truss system. Before use, the building designer must verify the applicability of design parameters and properly incorporate this design into the overall building design. Bracing indicated is to prevent buckling of individual truss web and/or chord members only. Additional temporary and permanent bracing is always required for stability and to prevent collapse with possible personal injury and property damage. For general guidance regarding the fabrication, storage, delivery, erection and bracing of trusses and truss systems, see ANSITP11 Quality Criteria, DSB-89 and BCSI Building Component

Safety Information available from Truss Plate Institute, 218 N. Lee Street, Suite 312, Alexandria, VA 22314.

ENGINEERING BY
TRENCO
A MiTek Affiliate

818 Soundside Road
Edenton, NC 27932

Job	Truss	Truss Type	Qty	Ply	2307- JRT -DAKOTA II	141378000
2000367-2000367A	V2	Valley	1	1	Job Reference (optional)	

84 Components (Dunn), Dunn, NC - 28334.

8.330 s May 6 2020 MiTek Industries, Inc. Wed May 20 13:02:18 2020 Page 1
 ID:ceuvEDckNGn_oUaH?G0U8dzEcIS-E9j19Tfoe8tLH_YUEhe4yNqVsn0y8jfF2aWgmPzEbjj

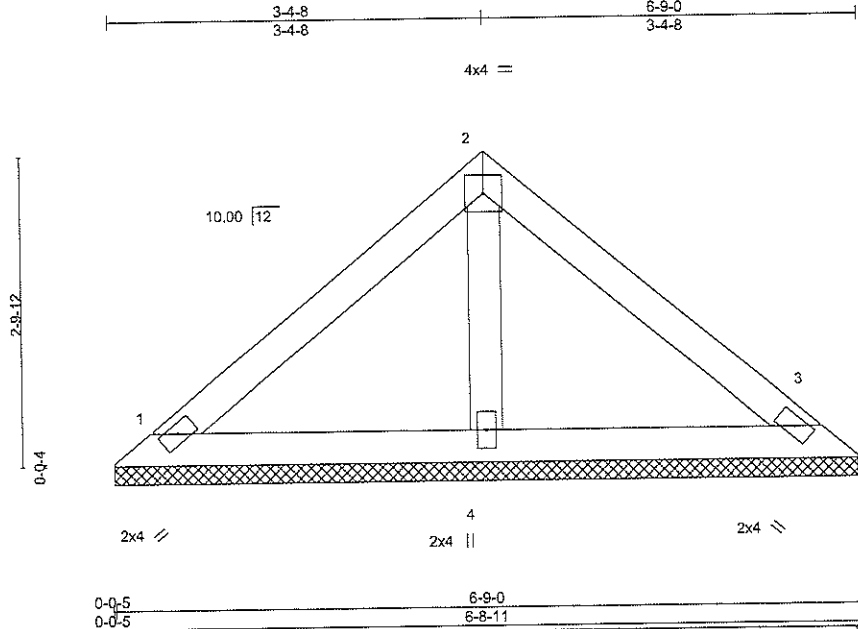

Scale = 1:20.0

LOADING (psf)	SPACING-	CSI.	DEFL.	PLATES	GRIP
TCLL 20.0	2-0-0	TC 0.16	in (loc) l/defl L/d	MT20	244/190
TCDL 10.0	Plate Grip DOL 1.15	BC 0.09	Vert(LL) n/a - n/a 999		
BCLL 0.0	Lumber DOL 1.15	WB 0.03	Vert(CT) n/a - n/a 999		
BCDL 10.0	Rep Stress Incr YES	Matrix-P	Horz(CT) 0.00 3 n/a n/a	Weight: 25 lb	FT = 20%
	Code IRC2015/TPI2014				

LUMBER-
 TOP CHORD 2x4 SP No.2
 BOT CHORD 2x4 SP No.2
 OTHERS 2x4 SP No.3

BRACING-
 TOP CHORD Structural wood sheathing directly applied or 6-0-0 oc purfins.
 BOT CHORD Rigid ceiling directly applied or 10-0-0 oc bracing.

REACTIONS. (size) 1=6-8-6, 3=6-8-6, 4=6-8-6
 Max Horz 1=-61(LC 8)
 Max Uplift 1=-29(LC 13), 3=-36(LC 13)
 Max Grav 1=136(LC 1), 3=136(LC 1), 4=203(LC 1)

FORCES. (lb) - Max. Comp./Max. Ten. - All forces 250 (lb) or less except when shown.

- NOTES-**
- 1) Unbalanced roof live loads have been considered for this design.
 - 2) Wind: ASCE 7-10; Vult=130mph (3-second gust) Vasd=103mph; TCDL=6.0psf; BCDL=6.0psf; h=30ft; Cat. II; Exp B; Enclosed; MWFRS (envelope) gable end zone and C-C Exterior(2) zone; cantilever left and right exposed; end vertical left and right exposed; C-C for members and forces & MWFRS for reactions shown; Lumber DOL=1.60 plate grip DOL=1.60
 - 3) Gable requires continuous bottom chord bearing.
 - 4) This truss has been designed for a 10.0 psf bottom chord live load nonconcurrent with any other live loads.
 - 5) * This truss has been designed for a live load of 20.0psf on the bottom chord in all areas where a rectangle 3-6-0 tall by 2-0-0 wide will fit between the bottom chord and any other members.

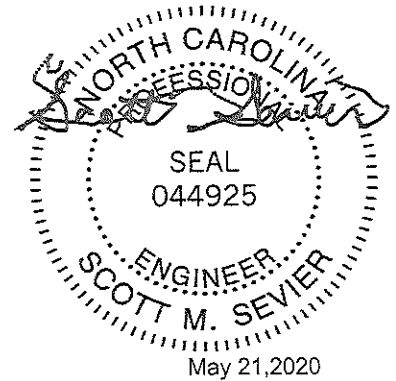

WARNING - Verify design parameters and READ NOTES ON THIS AND INCLUDED MITEK REFERENCE PAGE MH-7473 rev. 10/03/2015 BEFORE USE.

Design valid for use only with MiTek® connectors. This design is based only upon parameters shown, and is for an individual building component, not a truss system. Before use, the building designer must verify the applicability of design parameters and properly incorporate this design into the overall building design. Bracing indicated is to prevent buckling of individual truss web and/or chord members only. Additional temporary and permanent bracing is always required for stability and to prevent collapse with possible personal injury and property damage. For general guidance regarding the fabrication, storage, delivery, erection and bracing of trusses and truss systems, see ANSITPI1 Quality Criteria, DSB-89 and BCSI Building Component Safety Information available from Truss Plate Institute, 218 N. Lee Street, Suite 312, Alexandria, VA 22314.

ENGINEERING BY
TRENCO
 A MiTek Affiliate

818 Soundside Road
 Edenton, NC 27932

Job 2000367-2000367A	Truss V3	Truss Type Valley	Qty 1	Ply 1	2307- JRT -DAKOTA II	141378001
-------------------------	-------------	----------------------	----------	----------	----------------------	-----------

84 Components (Dunn), Dunn, NC - 28334.

8.330 s May 6 2020 MiTek Industries, Inc. Wed May 20 13:02:19 2020 Page 1
ID:ceuvEDckNGn_oUaH?G0U8dzEclS-iLHPMpfRPS?Cv77goP9JUbNhiBLd6POHEGDlrzEbj

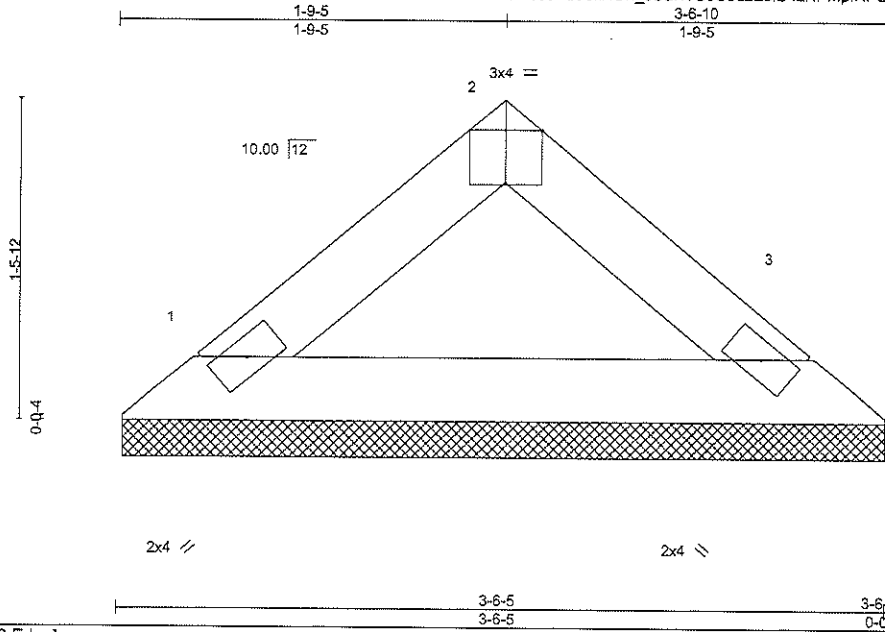

Scale = 1:10.2

Plate Offsets (X,Y) - [2:0-2:0,Edge]							
LOADING (psf)	SPACING-	CSI.	DEFL.	PLATES	GRIP		
TCLL 20.0	2-0-0	TC 0.03	in (loc) l/defl L/d	MT20	244/190		
TCDL 10.0	Plate Grip DOL 1.15	BC 0.09	Vert(LL) n/a - n/a 999				
BCLL 0.0 *	Lumber DOL 1.15	WB 0.00	Vert(CT) n/a - n/a 999				
BCDL 10.0	Rep Stress Incr YES	Matrix-P	Horz(CT) 0.00 3 n/a n/a				
	Code IRC2015/TPI2014						
						Weight: 11 lb	FT = 20%

LUMBER-	BRACING-
TOP CHORD 2x4 SP No.2	TOP CHORD Structural wood sheathing directly applied or 3-6-10 oc purlins.
BOT CHORD 2x4 SP No.2	BOT CHORD Rigid ceiling directly applied or 10-0-0 oc bracing.

REACTIONS. (size) 1=3-6-0, 3=3-6-0
 Max Horz 1=-28(LC 8)
 Max Uplift 1=-10(LC 12), 3=-10(LC 13)
 Max Grav 1=110(LC 1), 3=110(LC 1)

FORCES. (lb) - Max. Comp./Max. Ten. - All forces 250 (lb) or less except when shown.

- NOTES-**
- 1) Unbalanced roof live loads have been considered for this design.
 - 2) Wind: ASCE 7-10; Vult=130mph (3-second gust) Vasd=103mph; TCDL=6.0psf; BCDL=6.0psf; h=30ft; Cat. II; Exp B; Enclosed; MWFRS (envelope) gable end zone and C-C Exterior(2) zone; cantilever left and right exposed; end vertical left and right exposed; C-C for members and forces & MWFRS for reactions shown: Lumber DOL=1.60 plate grip DOL=1.60
 - 3) Gable requires continuous bottom chord bearing.
 - 4) This truss has been designed for a 10.0 psf bottom chord live load nonconcurrent with any other live loads.
 - 5) * This truss has been designed for a live load of 20.0psf on the bottom chord in all areas where a rectangle 3-6-0 tall by 2-0-0 wide will fit between the bottom chord and any other members.

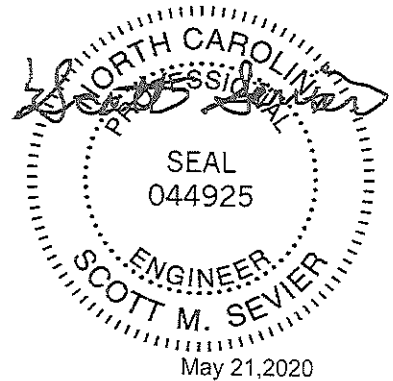

<p>WARNING - Verify design parameters and READ NOTES ON THIS AND INCLUDED MITEK REFERENCE PAGE MI-7473 rev. 10/03/2015 BEFORE USE.</p> <p>Design valid for use only with MiTek® connectors. This design is based only upon parameters shown, and is for an individual building component, not a truss system. Before use, the building designer must verify the applicability of design parameters and properly incorporate this design into the overall building design. Bracing indicated is to prevent buckling of individual truss web and/or chord members only. Additional temporary and permanent bracing is always required for stability and to prevent collapse with possible personal injury and property damage. For general guidance regarding the fabrication, storage, delivery, erection and bracing of trusses and truss systems, see ANSITP11 Quality Criteria, DSB-89 and BCSI Building Component Safety Information available from Truss Plate Institute, 218 N. Lee Street, Suite 312, Alexandria, VA 22314.</p>	<p>ENGINEERING BY TRENCO <small>A MITEK AFFILIATE</small></p> <p>818 Soundside Road Edenton, NC 27932</p>
--	--

Job	Truss	Truss Type	Qty	Ply	2307- JRT -DAKOTA II	I41378002
2000367-2000367A	V4	Valley	1	1	Job Reference (optional)	

84 Components (Dunn), Dunn, NC - 28334,

8.330 s May 6 2020 MiTek Industries, Inc. Wed May 20 13:02:20 2020 Page 1
 ID:ceuvEDckNGn_oUaH?G0U8dzEclS-AXroa9g3Am73WHisM6gY1owoGbgCcZzYVu?nqHzEbjH

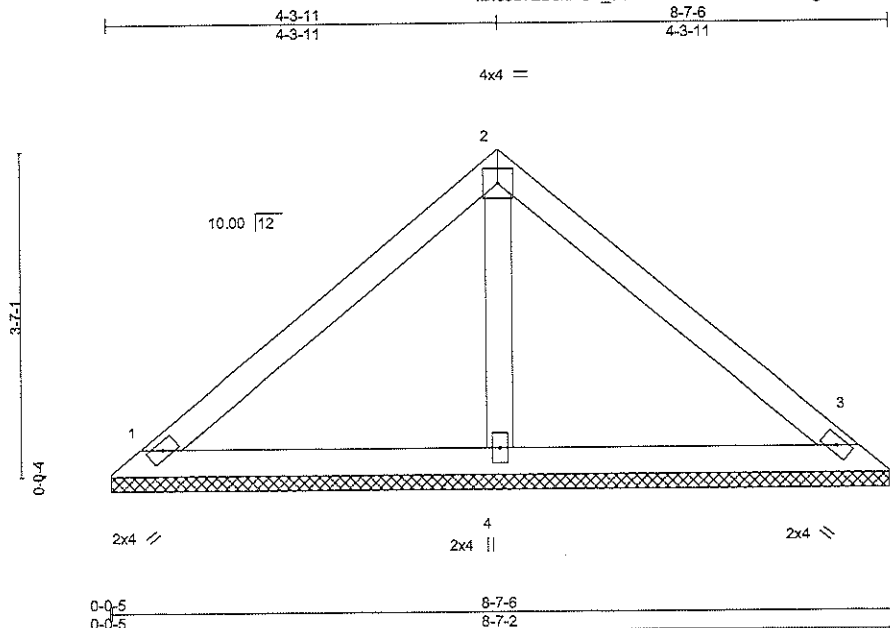

Scale = 1:24.4

LOADING (psf)	SPACING-	2-0-0	CSI.	DEFL.	in (loc)	l/defl	L/d	PLATES	GRIP
TCLL 20.0	Plate Grip DOL	1.15	TC 0.30	Vert(LL)	n/a	-	n/a	MT20	244/190
TCDL 10.0	Lumber DOL	1.15	BC 0.15	Vert(CT)	n/a	-	n/a		
BCLL 0.0	Rep Stress Incr	YES	WB 0.04	Horz(CT)	0.00	3	n/a		
BCDL 10.0	Code IRC2015/TPI2014		Matrix-P					Weight: 32 lb	FT = 20%

LUMBER-
 TOP CHORD 2x4 SP No.2
 BOT CHORD 2x4 SP No.2
 OTHERS 2x4 SP No.3

BRACING-
 TOP CHORD Structural wood sheathing directly applied or 6-0-0 oc purlins.
 BOT CHORD Rigid ceiling directly applied or 10-0-0 oc bracing.

REACTIONS. (size) 1=8-6-13, 3=8-6-13, 4=8-6-13
 Max Horz 1=-80(LC 8)
 Max Uplift 1=-37(LC 13), 3=-47(LC 13)
 Max Grav 1=179(LC 1), 3=179(LC 1), 4=266(LC 1)

FORCES. (lb) - Max. Comp./Max. Ten. - All forces 250 (lb) or less except when shown.

- NOTES-**
- 1) Unbalanced roof live loads have been considered for this design.
 - 2) Wind: ASCE 7-10; Vult=130mph (3-second gust) Vasd=103mph; TCDL=6.0psf; BCDL=6.0psf; h=30ft; Cat. II; Exp B; Enclosed; MWFRS (envelope) gable end zone and C-C Exterior(2) zone; cantilever left and right exposed; end vertical left and right exposed; C-C for members and forces & MWFRS for reactions shown; Lumber DOL=1.60 plate grip DOL=1.60
 - 3) Gable requires continuous bottom chord bearing.
 - 4) This truss has been designed for a 10.0 psf bottom chord live load nonconcurrent with any other live loads.
 - 5) * This truss has been designed for a live load of 20.0psf on the bottom chord in all areas where a rectangle 3-6-0 tall by 2-0-0 wide will fit between the bottom chord and any other members.

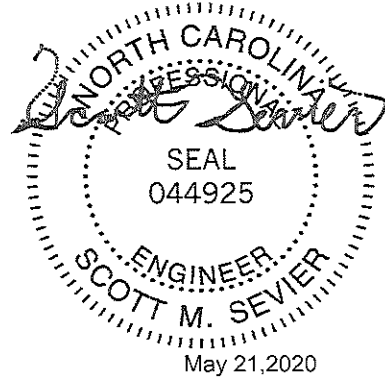

<p>WARNING - Verify design parameters and READ NOTES ON THIS AND INCLUDED MITEK REFERENCE PAGE MII-7473 rev. 10/03/2015 BEFORE USE. Design valid for use only with MiTek® connectors. This design is based only upon parameters shown, and is for an individual building component, not a truss system. Before use, the building designer must verify the applicability of design parameters and properly incorporate this design into the overall building design. Bracing indicated is to prevent buckling of individual truss web and/or chord members only. Additional temporary and permanent bracing is always required for stability and to prevent collapse with possible personal injury and property damage. For general guidance regarding the fabrication, storage, delivery, erection and bracing of trusses and truss systems, see ANSI/TPI1 Quality Criteria, DSB-89 and CSI Building Component Safety Information available from Truss Plate Institute, 218 N. Lee Street, Suite 312, Alexandria, VA 22314.</p>	<p>ENGINEERING BY TRENCO <small>A MiTek Affiliate</small></p> <p>818 Soundside Road Edenton, NC 27932</p>
---	---

Job	Truss	Truss Type	Qty	Ply	2307- JRT -DAKOTA II	141378003
2000367-2000367A	V5	Valley	1	1		

84 Components (Dunn), Dunn, NC - 28334.

8,330 s May 6 2020 MiTek Industries, Inc. Wed May 20 13:02:20 2020 Page 1

ID:ceuvEDckNGn_oUaH?G0U8dzEclS-AXroa9g3Am73WHisM6gY1owrRbj_cZLYVv?nqHzEbjH

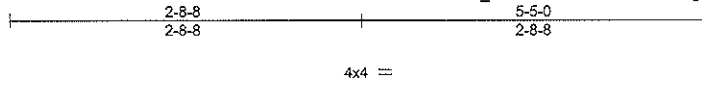

Scale = 1:17.1

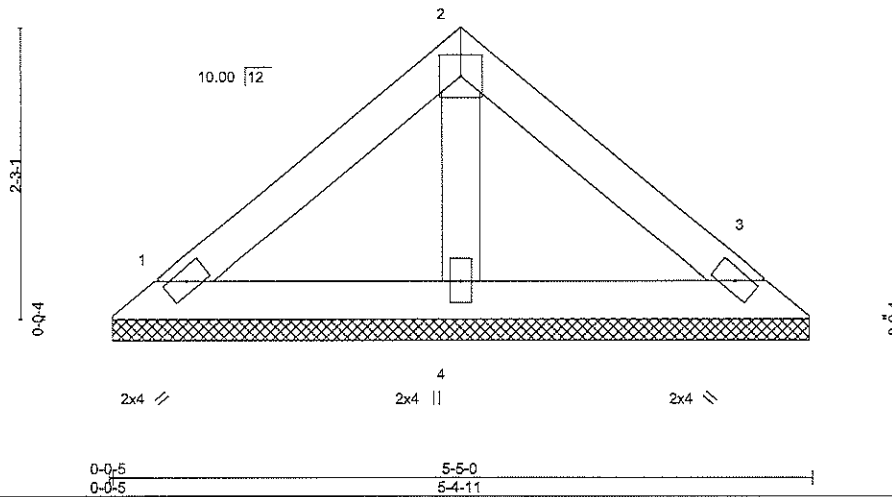

LOADING (psf)	SPACING-	CSL	DEFL.	PLATES	GRIP
TCLL 20.0	2-0-0	TC 0.09	in (loc) l/defl L/d	MT20	244/190
TCDL 10.0	Plate Grip DOL 1.15	BC 0.05	Vert(LL) n/a - n/a 999		
BCLL 0.0 *	Lumber DOL 1.15	WB 0.02	Vert(CT) n/a - n/a 999		
BCDL 10.0	Rep Stress Incr YES	Matrix-P	Horz(CT) 0.00 3 n/a n/a		
	Code IRC2015/TPI2014			Weight: 19 lb	FT = 20%

LUMBER-
 TOP CHORD 2x4 SP No.2
 BOT CHORD 2x4 SP No.2
 OTHERS 2x4 SP No.3

BRACING-
 TOP CHORD Structural wood sheathing directly applied or 5-5-0 oc purfins.
 BOT CHORD Rigid ceiling directly applied or 10-0-0 oc bracing.

REACTIONS. (size) 1=5-4-6, 3=5-4-6, 4=5-4-6
 Max Horz 1=-48(LC 8)
 Max Uplift 1=-22(LC 13), 3=-28(LC 13)
 Max Grav 1=106(LC 1), 3=106(LC 1), 4=157(LC 1)

FORCES. (lb) - Max. Comp./Max. Ten. - All forces 250 (lb) or less except when shown.

- NOTES-**
- 1) Unbalanced roof live loads have been considered for this design.
 - 2) Wind: ASCE 7-10; Vult=130mph (3-second gust) Vasd=103mph; TCDL=6.0psf; BCDL=6.0psf; h=30ft; Cat. II; Exp B; Enclosed; MWFRS (envelope) gable end zone and C-C Exterior(2) zone; cantilever left and right exposed; end vertical left and right exposed; C-C for members and forces & MWFRS for reactions shown; Lumber DOL=1.60 plate grip DOL=1.60
 - 3) Gable requires continuous bottom chord bearing.
 - 4) This truss has been designed for a 10.0 psf bottom chord live load nonconcurrent with any other live loads.
 - 5) * This truss has been designed for a live load of 20.0psf on the bottom chord in all areas where a rectangle 3-6-0 tall by 2-0-0 wide will fit between the bottom chord and any other members.

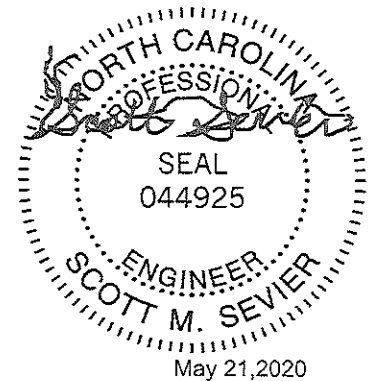

WARNING - Verify design parameters and READ NOTES ON THIS AND INCLUDED MITEK REFERENCE PAGE MI-7473 rev. 10/03/2015 BEFORE USE.
 Design valid for use only with MiTek® connectors. This design is based only upon parameters shown, and is for an individual building component, not a truss system. Before use, the building designer must verify the applicability of design parameters and properly incorporate this design into the overall building design. Bracing indicated is to prevent buckling of individual truss web and/or chord members only. Additional temporary and permanent bracing is always required for stability and to prevent collapse with possible personal injury and property damage. For general guidance regarding the fabrication, storage, delivery, erection and bracing of trusses and truss systems, see ANSI/TPI1 Quality Criteria, DSB-89 and BCSI Building Component Safety Information available from Truss Plate Institute, 218 N. Lee Street, Suite 312, Alexandria, VA 22314.

ENGINEERING BY
TRENCO
 A MiTek Affiliate
 818 Soundside Road
 Edenton, NC 27932

Symbols

PLATE LOCATION AND ORIENTATION

Center plate on joint unless x, y offsets are indicated. Dimensions are in ft-in-sixteenths. Apply plates to both sides of truss and fully embed teeth.

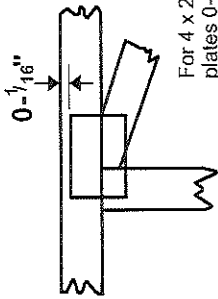

For 4 x 2 orientation, locate plates 0- 1/16" from outside edge of truss.

This symbol indicates the required direction of slots in connector plates.

* Plate location details available in MiTek 20/20 software or upon request.

PLATE SIZE

4 X 4

The first dimension is the plate width measured perpendicular to slots. Second dimension is the length parallel to slots.

LATERAL BRACING LOCATION



Indicated by symbol shown and/or by text in the bracing section of the output. Use T or I bracing if indicated.

BEARING

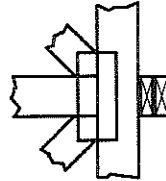

Indicates location where bearings (supports) occur. Icons vary but reaction section indicates joint number where bearings occur. Min size shown is for crusting only.

Industry Standards:

- ANSI/TPI1: National Design Specification for Metal Plate Connected Wood Truss Construction.
- DSB-89: Design Standard for Bracing.
- BCSI: Building Component Safety Information, Guide to Good Practice for Handling, Installing & Bracing of Metal Plate Connected Wood Trusses.

Numbering System

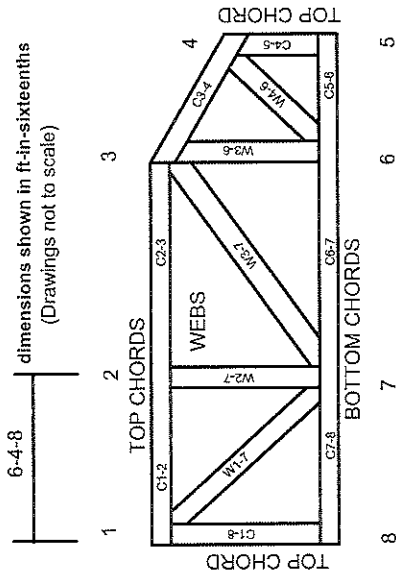

JOINTS ARE GENERALLY NUMBERED/CLOCKWISE AROUND THE TRUSS STARTING AT THE JOINT FARTHEST TO THE LEFT.

CHORDS AND WEBS ARE IDENTIFIED BY END JOINT NUMBERS/LETTERS.

PRODUCT CODE APPROVALS

ICC-ES Reports:

ESR-1311, ESR-1352, ESR1988
ER-3907, ESR-2362, ESR-1397, ESR-3282

Trusses are designed for wind loads in the plane of the truss unless otherwise shown.

Lumber design values are in accordance with ANSI/TPI 1 section 6.3 These truss designs rely on lumber values established by others.

© 2012 MiTek® All Rights Reserved

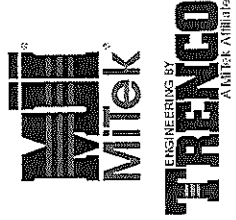

MiTek Engineering Reference Sheet: MII-7473 rev. 10/03/2015

General Safety Notes

Failure to Follow Could Cause Property Damage or Personal Injury

- Additional stability bracing for truss system, e.g. diagonal or X-bracing, is always required. See BCSI.
- Truss bracing must be designed by an engineer. For wide truss spacing, individual lateral braces themselves may require bracing, or alternative Top 1 bracing should be considered.
- Never exceed the design loading shown and never stack materials on inadequately braced trusses.
- Provide copies of this truss design to the building designer, erection supervisor, property owner and all other interested parties.
- Out members to bear tightly against each other.
- Place plates on each face of truss at each joint and embed fully. Knots and wane at joint locations are regulated by ANSI/TPI 1.
- Design assumes trusses will be suitably protected from the environment in accord with ANSI/TPI 1.
- Unless otherwise noted, moisture content of lumber shall not exceed 19% at time of fabrication.
- Unless expressly noted, this design is not applicable for use with fire retardant, preservative treated, or green lumber.
- Camber is a non-structural consideration and is the responsibility of truss fabricator. General practice is to camber for dead load deflection.
- Plate type, size, orientation and location dimensions indicated are minimum plating requirements.
- Lumber used shall be of the species and size, and in all respects, equal to or better than that specified.
- Top chords must be sheathed or purlins provided at spacing indicated on design.
- Bottom chords require lateral bracing at 10 ft. spacing, or less, if no ceiling is installed, unless otherwise noted.
- Connections not shown are the responsibility of others.
- Do not cut or alter truss member or plate without prior approval of an engineer.
- Install and load vertically unless indicated otherwise.
- Use of green or treated lumber may pose unacceptable environmental, health or performance risks. Consult with project engineer before use.
- Review all portions of this design (front, back, words and pictures) before use. Reviewing pictures alone is not sufficient.
- Design assumes manufacture in accordance with ANSI/TPI 1 Quality Criteria.

Job 2000367-2000367A	Truss V1	Truss Type Valley	Qty 1	Ply 1	2307- JRT -DAKOTA II	I41377999
-------------------------	-------------	----------------------	----------	----------	----------------------	-----------

84 Components (Dunn), Dunn, NC - 28334,

8,330 s May 6 2020 MITek Industries, Inc. Wed May 20 13:02:17 2020 Page 1
 ID:ceuvEDckNGn_oUaH?G0U8dzEciS-lz9fy7eAtrIUfqzHg_7rPAI11NeqPBt6pwn7DyzEbjK
 9-11-6

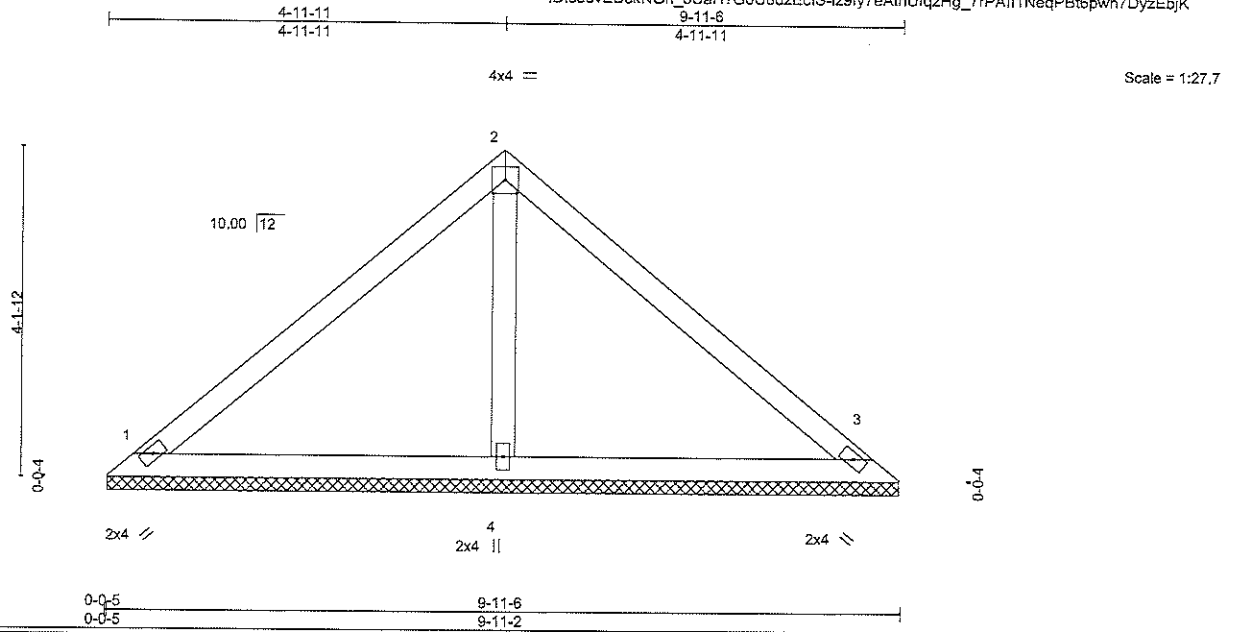

LOADING (psf)	SPACING-	CSI.	DEFL.	PLATES	GRIP
TCLL 20.0	2-0-0	TC 0.30	in (loc) l/defl L/d	MT20	244/190
TCDL 10.0	Plate Grip DOL 1.15	BC 0.21	Vert(LL) n/a - n/a 999		
BCLL 0.0 *	Lumber DOL 1.15	WB 0.07	Vert(CT) n/a - n/a 999		
BCDL 10.0	Rep Stress Incr YES	Matrix-S	Horz(CT) 0.00 3 n/a n/a	Weight: 38 lb	FT = 20%
	Code IRC2015/TPI2014				

LUMBER-

TOP CHORD 2x4 SP No.2
 BOT CHORD 2x4 SP No.2
 OTHERS 2x4 SP No.3

BRACING-

TOP CHORD Structural wood sheathing directly applied or 6-0-0 oc purlins.
 BOT CHORD Rigid ceiling directly applied or 10-0-0 oc bracing.

REACTIONS.

(size) 1=9-10-13, 3=9-10-13, 4=9-10-13
 Max Horz 1=-94(LC 8)
 Max Uplift 1=-32(LC 13), 3=-43(LC 13), 4=-7(LC 12)
 Max Grav 1=194(LC 1), 3=194(LC 1), 4=344(LC 1)

FORCES. (lb) - Max. Comp./Max. Ten. - All forces 250 (lb) or less except when shown.

NOTES-

- Unbalanced roof live loads have been considered for this design.
- Wind: ASCE 7-10; Vult=130mph (3-second gust) Vasd=103mph; TCDL=6.0psf; BCDL=6.0psf; h=30ft; Cat. II; Exp B; Enclosed; MWFRS (envelope) gable end zone and C-C Exterior(2) zone: cantilever left and right exposed ; end vertical left and right exposed;C-C for members and forces & MWFRS for reactions shown; Lumber DOL=1.60 plate grip DOL=1.60
- Gable requires continuous bottom chord bearing.
- This truss has been designed for a 10.0 psf bottom chord live load nonconcurrent with any other live loads.
- * This truss has been designed for a live load of 20.0psf on the bottom chord in all areas where a rectangle 3-6-0 tall by 2-0-0 wide will fit between the bottom chord and any other members.

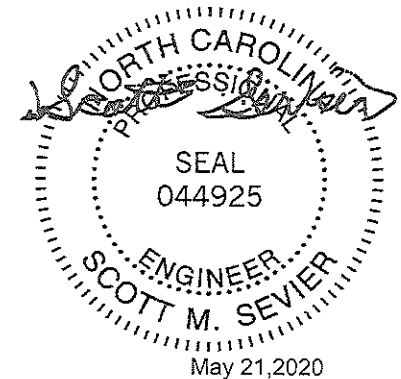

WARNING - Verify design parameters and READ NOTES ON THIS AND INCLUDED MITEK REFERENCE PAGE MII-7473 rev. 10/03/2015 BEFORE USE.

Design valid for use only with MITek® connectors. This design is based only upon parameters shown, and is for an individual building component, not a truss system. Before use, the building designer must verify the applicability of design parameters and properly incorporate this design into the overall building design. Bracing indicated is to prevent buckling of individual truss web and/or chord members only. Additional temporary and permanent bracing is always required for stability and to prevent collapse with possible personal injury and property damage. For general guidance regarding the fabrication, storage, delivery, erection and bracing of trusses and truss systems, see ANSI/TPI1 Quality Criteria, DSB-89 and BCSI Building Component Safety Information available from Truss Plate Institute, 218 N. Lee Street, Suite 312, Alexandria, VA 22314.

ENGINEERING BY
TRENCO
 A MITek Affiliate

818 Soundside Road
 Edenton, NC 27932

Job 2000367-2000367A	Truss M1	Truss Type Monopitch	Qty 9	Ply 1	2307- JRT -DAKOTA II	141377998
-------------------------	-------------	-------------------------	----------	----------	----------------------	-----------

84 Components (Dunn), Dunn, NC - 28334,

8.330 s May 6 2020 MiTek Industries, Inc. Wed May 20 13:02:16 2020 Page 1
ID:ceuvEDckNGn_oUaH?G0U8dzEclS-HmchKodY6Xdd2gO57GccsyI7dzlAgIfybG1ZhWzEbjL

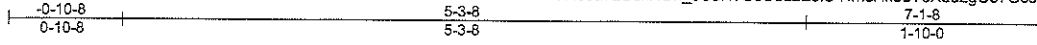

Scale = 1:17.1

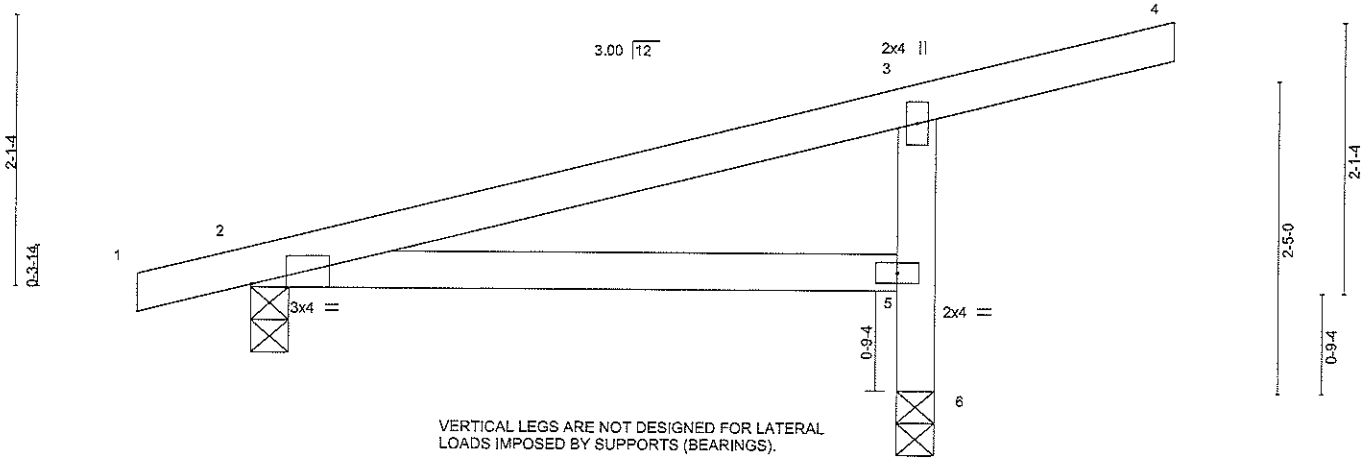

Plate Offsets (X,Y)-- [2:0-3-4,Edge]

LOADING (psf)	SPACING-	2-0-0	CSI.	DEFL.	in (loc)	l/defl	L/d	PLATES	GRIP
TCLL 20.0	Plate Grip DOL	1.15	TC 0.28	Vert(LL)	0.03 5-9	>999	240	MT20	244/190
TCDL 10.0	Lumber DOL	1.15	BC 0.24	Vert(CT)	-0.06 5-9	>999	180		
BCLL 0.0 *	Rep Stress Incr	YES	WB 0.00	Horz(CT)	0.00 6	n/a	n/a		
BCDL 10.0	Code IRC2015/TPI2014		Matrix-MP					Weight: 23 lb	FT = 20%

LUMBER-	BRACING-
TOP CHORD 2x4 SP No.2	TOP CHORD Structural wood sheathing directly applied or 5-3-8 oc purlins, except end verticals.
BOT CHORD 2x4 SP No.2	BOT CHORD Rigid ceiling directly applied or 10-0-0 oc bracing.
WEBS 2x4 SP No.3	

REACTIONS. (size) 2=0-3-8, 6=0-3-8
 Max Horz 2=92(LC 11)
 Max Uplift 2=-58(LC 8), 6=-96(LC 12)
 Max Grav 2=240(LC 1), 6=343(LC 1)

FORCES. (lb) - Max. Comp./Max. Ten. - All forces 250 (lb) or less except when shown.
 TOP CHORD 5-6=-343/231, 3-5=-283/242

- NOTES-**
- 1) Wind: ASCE 7-10; Vult=130mph (3-second gust) Vasd=103mph; TCCL=6.0psf; BCDL=6.0psf; h=30ft; Cat. II; Exp B; Enclosed; MWFRS (envelope) gable end zone and C-C Exterior(2) zone; cantilever left and right exposed; end vertical left and right exposed; C-C for members and forces & MWFRS for reactions shown; Lumber DOL=1.80 plate grip DOL=1.60
 - 2) This truss has been designed for a 10.0 psf bottom chord live load nonconcurrent with any other live loads.
 - 3) * This truss has been designed for a live load of 20.0psf on the bottom chord in all areas where a rectangle 3-6-0 tall by 2-0-0 wide will fit between the bottom chord and any other members.
 - 4) Bearing at joint(s) 6 considers parallel to grain value using ANSI/TPI 1 angle to grain formula. Building designer should verify capacity of bearing surface.
 - 5) One H2.5A Simpson Strong-Tie connectors recommended to connect truss to bearing walls due to UPLIFT at jt(s) 2 and 6. This connection is for uplift only and does not consider lateral forces.

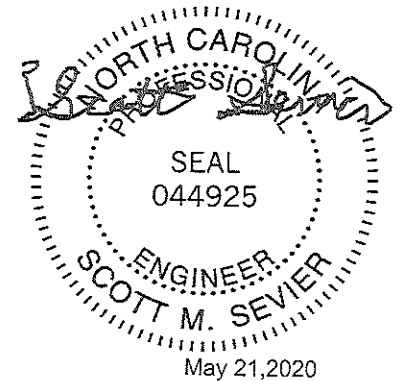

WARNING - Verify design parameters and READ NOTES ON THIS AND INCLUDED MITEK REFERENCE PAGE MII-7473 rev. 10/03/2015 BEFORE USE.
 Design valid for use only with MiTek® connectors. This design is based only upon parameters shown, and is for an individual building component, not a truss system. Before use, the building designer must verify the applicability of design parameters and properly incorporate this design into the overall building design. Bracing indicated is to prevent buckling of individual truss web and/or chord members only. Additional temporary and permanent bracing is always required for stability and to prevent collapse with possible personal injury and property damage. For general guidance regarding the fabrication, storage, delivery, erection and bracing of trusses and truss systems, see ANSI/TPI1 Quality Criteria, DSB-89 and BCSI Building Component Safety Information available from Truss Plate Institute, 218 N. Lee Street, Suite 312, Alexandria, VA 22314.

ENGINEERING BY TRENCO
 A MiTek Affiliate
 818 Soundside Road
 Edenton, NC 27932

Job 2000367-2000367A	Truss AE	Truss Type GABLE	Qty 1	Ply 1	2307- JRT -DAKOTA II	I41377990
84 Components (Dunn), Dunn, NC - 28334,		Job Reference (optional)				

8.330 s May 6 2020 MiTek Industries, Inc. Wed May 20 13:02:05 2020 Page 1

ID:ceuvEDckNGn_oUaH?G0U8dzEcIS-6R7Q1Vei9EBD_2_zTv1weoEXYZ2bhL32tUofzEbjW

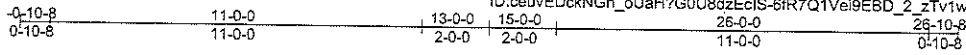

Scale = 1:65.6

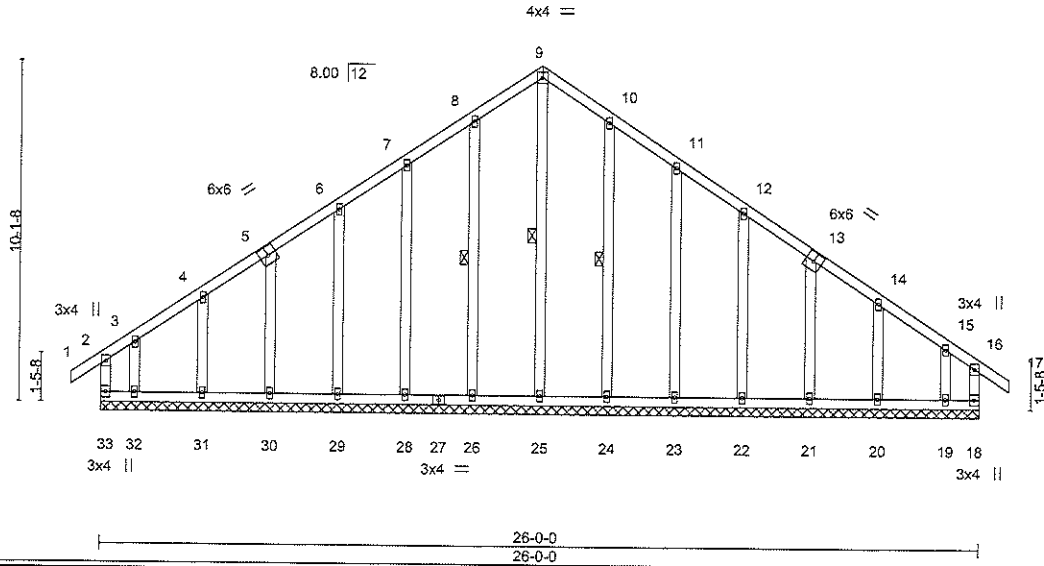

LOADING (psf)	SPACING-	CSI.	DEFL.	PLATES	GRIP
TCLL 20.0	2-0-0	TC 0.27	in (loc) l/defl L/d	MT20	244/190
TCDL 10.0	Plate Grip DOL 1.15	BC 0.15	Vert(LL) -0.00 17 n/r 120		
BCLL 0.0 *	Lumber DOL 1.15	WB 0.14	Vert(CT) -0.00 17 n/r 90		
BCDL 10.0	Rep Stress Incr YES	Matrix-R	Horz(CT) 0.01 18 n/a n/a		
	Code IRC2015/TPI2014			Weight: 194 lb	FT = 20%

LUMBER-
 TOP CHORD 2x4 SP No.2
 BOT CHORD 2x4 SP No.2
 WEBS 2x4 SP No.3
 OTHERS 2x4 SP No.3

BRACING-
 TOP CHORD Structural wood sheathing directly applied or 6-0-0 oc purlins, except end verticals.
 BOT CHORD Rigid ceiling directly applied or 6-0-0 oc bracing.
 WEBS 1 Row at midpt 9-25, 8-26, 10-24

REACTIONS. All bearings 26-0-0.
 (lb) - Max Horz 33=273(LC 11)
 Max Uplift All uplift 100 lb or less at joint(s) 26, 28, 29, 30, 31, 24, 23, 22, 21, 20 except 33=260(LC 8), 18=-209(LC 9), 32=-255(LC 9), 19=-216(LC 8)
 Max Grav All reactions 250 lb or less at joint(s) 18, 26, 28, 29, 30, 31, 24, 23, 22, 21, 20 except 33=303(LC 11), 25=269(LC 13), 32=320(LC 10), 19=279(LC 11)

FORCES. (lb) - Max. Comp./Max. Ten. - All forces 250 (lb) or less except when shown.
 TOP CHORD 7-8=-218/276, 8-9=-262/327, 9-10=-262/327, 10-11=-218/276
 WEBS 9-25=-294/172

- NOTES-**
- 1) Unbalanced roof live loads have been considered for this design.
 - 2) Wind: ASCE 7-10; Vult=130mph (3-second gust) Vasd=103mph; TCCL=6.0psf; BCCL=6.0psf; h=30ft; Cat. II; Exp B; Enclosed; MWFRS (envelope) gable end zone and C-C Exterior(2) zone; cantilever left and right exposed ; end vertical left and right exposed; C-C for members and forces & MWFRS for reactions shown; Lumber DOL=1.60 plate grip DOL=1.60
 - 3) Truss designed for wind loads in the plane of the truss only. For studs exposed to wind (normal to the face), see Standard Industry Gable End Details as applicable, or consult qualified building designer as per ANSI/TPI 1.
 - 4) All plates are 2x4 MT20 unless otherwise indicated.
 - 5) Gable requires continuous bottom chord bearing.
 - 6) Truss to be fully sheathed from one face or securely braced against lateral movement (i.e. diagonal web).
 - 7) Gable studs spaced at 2-0-0 oc.
 - 8) This truss has been designed for a 10.0 psf bottom chord live load nonconcurrent with any other live loads.
 - 9) * This truss has been designed for a live load of 20.0psf on the bottom chord in all areas where a rectangle 3-6-0 tall by 2-0-0 wide will fit between the bottom chord and any other members.
 - 10) N/A
 - 11) ATTIC SPACE SHOWN IS DESIGNED AS UNINHABITABLE.

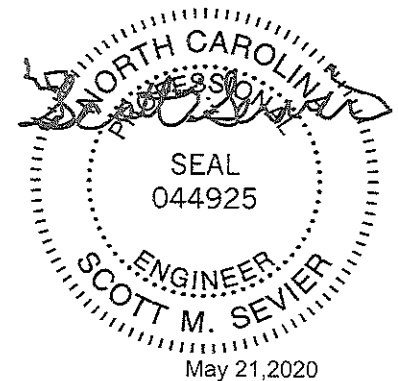

WARNING - Verify design parameters and READ NOTES ON THIS AND INCLUDED MITEK REFERENCE PAGE MII-7473 rev. 10/03/2015 BEFORE USE.
 Design valid for use only with MiTek® connectors. This design is based only upon parameters shown, and is for an individual building component, not a truss system. Before use, the building designer must verify the applicability of design parameters and properly incorporate this design into the overall building design. Bracing indicated is to prevent buckling of individual truss web and/or chord members only. Additional temporary and permanent bracing is always required for stability and to prevent collapse with possible personal injury and property damage. For general guidance regarding the fabrication, storage, delivery, erection and bracing of trusses and truss systems, see ANSI/TPH Quality Criteria, DSB-89 and BCSI Building Component Safety Information available from Truss Plate Institute, 218 N. Lee Street, Suite 312, Alexandria, VA 22314.

ENGINEERING BY
TRENCO
 A MiTek Affiliate
 818 Soundside Road
 Edenton, NC 27932

THIS LAYOUT IS INTENDED FOR THE PURPOSE OF TRUSS LOCATION AND PLACEMENT ONLY. REFER TO THE BUILDING PLANS FOR ACTUAL BUILDING CONSTRUCTION.

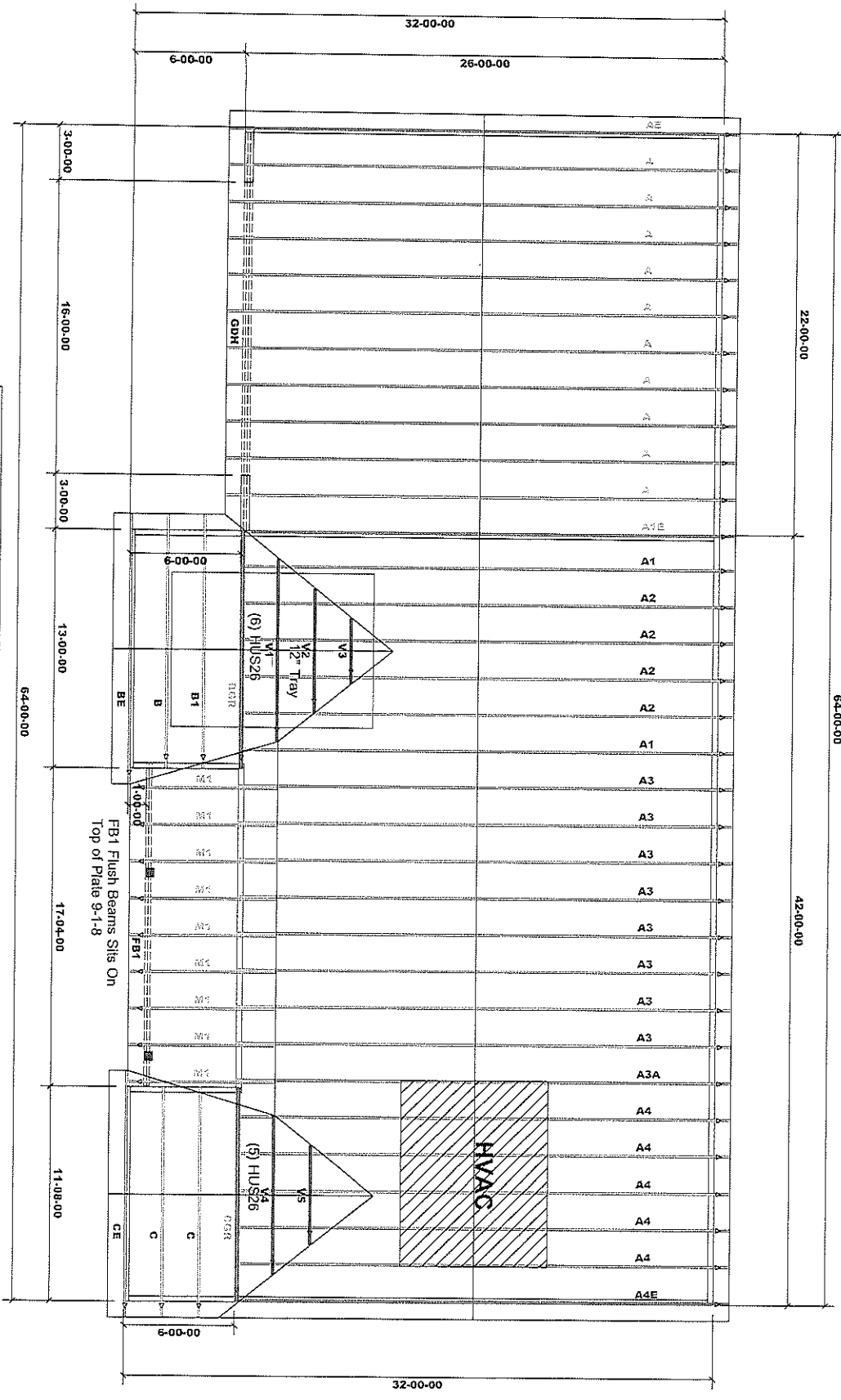

Fab Type	Net Qty	Piles	Products	Product	Length	Pile/D
MFD	2	2	1-3/4" x 9-1/4" VERSA-LAM® 2.0 3100 SP	18-00-00	FB1	
MFD	3	3	1-3/4" x 11-7/8" VERSA-LAM® 2.0 3100 SP	22-00-00	GPH	

Standard Roof Area 0
Zoned Roof Area 0

GENERAL NOTES:

- DO NOT CUT OR MODIFY TRUSSES
- TRUSSES ARE SPACED 24" ON CENTER UNLESS OTHERWISE NOTED
- REFER TO THE INDIVIDUAL TRUSS DESIGN DRAWINGS FOR THE LOCATION OF LATERAL BRACING AND MULTI-PLY CONNECTION REQUIREMENTS.
- PER ANSI TPI 1-2002 THE TRUSS ENGINEER IS RESPONSIBLE FOR TRUSS TO TRUSS CONNECTIONS AND TRUSS PLY TO PLY CONNECTIONS. THIS TRUSS LAYOUT PLAN RECOMMENDS TRUSS TO BEARING CONNECTIONS AND TRUSS TO BEAM CONNECTIONS WHICH SHALL BE REVIEWED BY THE BUILDING DESIGNER. IT IS THE RESPONSIBILITY OF THE BUILDING DESIGNER TO RESOLVE ALL ROOF FORCES ADEQUATELY TO THE FOUNDATION.

TOP LIVE LOAD: 20.0 PSF
TOP DEAD LOAD: 10.0 PSF
BOTTOM DEAD LOAD: 10.0 PSF
WIND SPEED: 130 mph

PROJECT: 2307- FAY - JRT - DAKOTA II
 CUSTOMER: 2307- 84 Fayetteville
 MODEL: THE DAKOTA II
 QUOTE #: 2000367
 PRINT DATE: 5/20/2020
 DRAWN BY: Rodney Evans
 SCALE: N.T.S.

DEDICATED TO QUALITY AND EXCELLENCE
 DUNN, NORTH CAROLINA 28534
 PHONE: 910.892.8100



Job 2000367-2000367A	Truss B	Truss Type Common	Qty 1	Ply 1	2307- JRT -DAKOTA II	141377991
-------------------------	------------	----------------------	----------	----------	----------------------	-----------

84 Components (Dunn), Dunn, NC - 28334,

8.330 s May 6 2020 MITek Industries, Inc. Wed May 20 13:02:07 2020 Page 1
 ID:ceuvEDckNGn_oUaH?G0U8dzEclS-21ZtrjWvEmUvSHCM5txV?3tUstLBD3g4dWMMbtXzEbjU

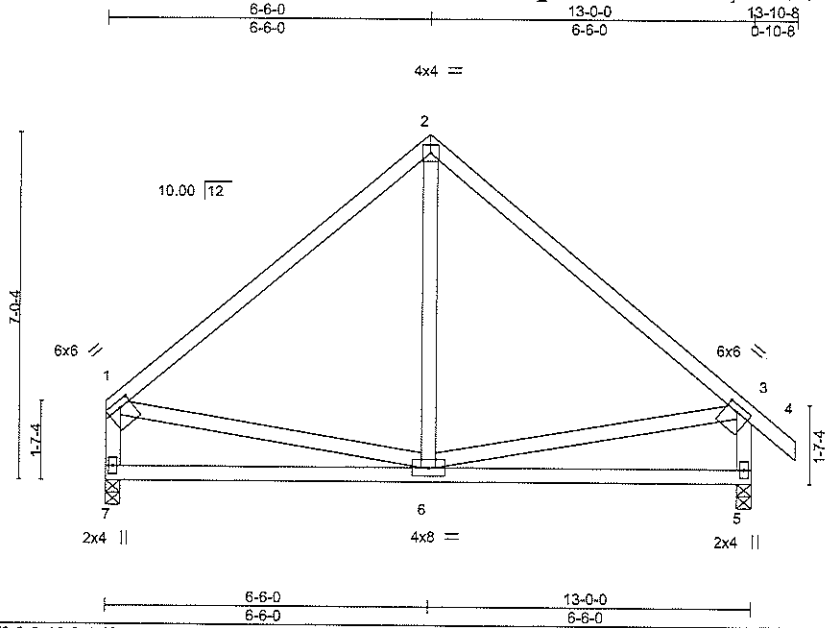

Scale = 1:44.6

Plate Offsets (X,Y)-- [1:0-2-12.0-1-8], [3:0-2-12.0-1-8]

LOADING (psf)	SPACING-	2-0-0	CSI.	DEFL.	in	(loc)	l/defl	L/d	PLATES	GRIP
TCLL 20.0	Plate Grip DOL	1.15	TC 0.66	Vert(LL)	-0.03	6-7	>999	240	MT20	244/190
TCDL 10.0	Lumber DOL	1.15	BC 0.36	Vert(CT)	-0.07	6-7	>999	180		
BCLL 0.0 *	Rep Stress Incr	YES	WB 0.09	Horz(CT)	0.00	5	n/a	n/a		
BCDL 10.0	Code IRC2015/TPI2014		Matrix-MS							
									Weight: 78 lb	FT = 20%

LUMBER-

TOP CHORD 2x4 SP No.2
 BOT CHORD 2x4 SP No.2
 WEBS 2x4 SP No.3

BRACING-

TOP CHORD Structural wood sheathing directly applied or 6'-0"-0 oc purlins, except end verticals.
 BOT CHORD Rigid ceiling directly applied or 10'-0"-0 oc bracing.

REACTIONS.

(size) 7=0-3-8, 5=0-3-8
 Max Horz 7=-195(LC 10)
 Max Uplift 7=-42(LC 12), 5=-61(LC 13)
 Max Grav 7=506(LC 1), 5=572(LC 1)

FORCES. (lb) - Max. Comp./Max. Ten. - All forces 250 (lb) or less except when shown.

TOP CHORD 1-2=-473/120, 2-3=-480/127, 1-7=-449/126, 3-5=-515/169
 BOT CHORD 6-7=-187/265

NOTES-

- Unbalanced roof live loads have been considered for this design.
- Wind: ASCE 7-10; Vult=130mph (3-second gust) Vasd=103mph; TCCL=6.0psf; BCDL=6.0psf; h=30ft; Cat. II; Exp B; Enclosed; MWFRS (envelope) gable end zone and C-C Exterior(2) zone; cantilever left and right exposed; end vertical left and right exposed; C-C for members and forces & MWFRS for reactions shown; Lumber DOL=1.60 plate grip DOL=1.60
- This truss has been designed for a 10.0 psf bottom chord live load nonconcurrent with any other live loads.
- * This truss has been designed for a live load of 20.0psf on the bottom chord in all areas where a rectangle 3'-6" tall by 2'-0" wide will fit between the bottom chord and any other members.
- One H2.5A Simpson Strong-Tie connectors recommended to connect truss to bearing walls due to UPLIFT at jt(s) 7 and 5. This connection is for uplift only and does not consider lateral forces.

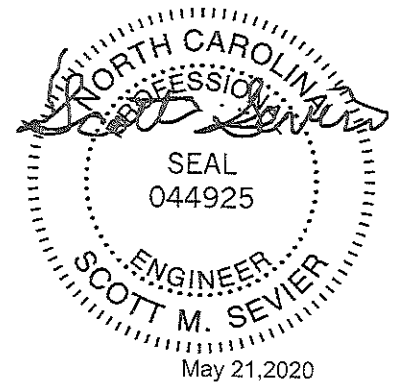

WARNING - Verify design parameters and READ NOTES ON THIS AND INCLUDED MITEK REFERENCE PAGE MIH-7473 rev. 10/03/2015 BEFORE USE.

Design valid for use only with MITek® connectors. This design is based only upon parameters shown, and is for an individual building component, not a truss system. Before use, the building designer must verify the applicability of design parameters and properly incorporate this design into the overall building design. Bracing indicated is to prevent buckling of individual truss web and/or chord members only. Additional temporary and permanent bracing is always required for stability and to prevent collapse with possible personal injury and property damage. For general guidance regarding the fabrication, storage, delivery, erection and bracing of trusses and truss systems, see ANSI/TPI1 Quality Criteria, DSS-89 and BCSI Building Component Safety Information available from Truss Plate Institute, 218 N. Lee Street, Suite 312, Alexandria, VA 22314.



818 Soundside Road
 Edenton, NC 27932