

**REVERSE**

THIS DRAWING HAS BEEN FULLY REVERSED PLEASE VERIFY ORIENTATION

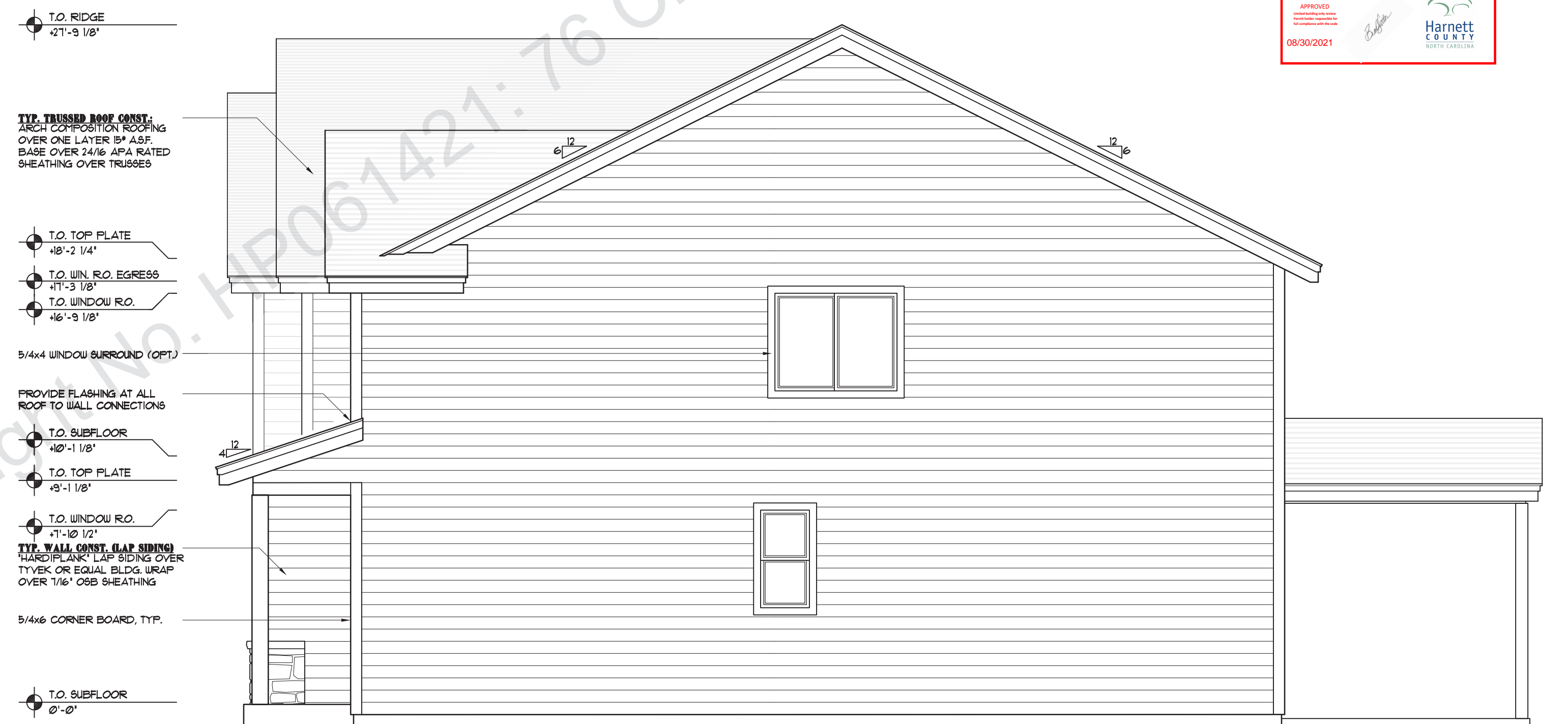

**FRONT ELEVATION**  
SCALE: 1/4"=1'-0"



**RIGHT ELEVATION**  
SCALE: 1/4"=1'-0"



DISREGARD STRUCTURAL ITEMS DENOTED ON THE ARCHITECTURAL PLANS. REFER TO THE SEALED STRUCTURAL PLANS FOR ALL STRUCTURAL SPECIFICATIONS. THE STRUCTURAL PLANS WERE ENGINEERED WITH FRAMING SPECIFICATIONS PROVIDED BY THE BUILDER.

**AVERY J**

PLAN NUMBER 52214J

2,325 TOTAL SQUARE FEET



THESE PLANS HAVE BEEN LICENSED FOR THE CONSTRUCTION OF ONE BUILDING ONLY. UNAUTHORIZED USE OR COPYING OF THE PLANS OR THE DESIGN THEREOF, VIOLATES RIGHTS UNDER THE COPYRIGHT ACT THAT INCLUDE PENALTIES OF UP TO \$200,000 PER WORK WILLFULLY INFRINGED. THESE PLANS HAVE BEEN PREPARED TO MEET IRC BUILDING CODES AND MAY REQUIRE ADAPTATION TO MEET SPECIFIC SITE CONDITIONS AND LOCAL BUILDING REGULATIONS. IT IS THE CONTRACTOR'S SOLE RESPONSIBILITY TO VERIFY ALL DIMENSIONS AND DETAILS PRIOR TO CONSTRUCTION FOR ERRORS AND OMISSIONS. PLEASE SEE YOUR LICENSE AGREEMENT FOR FURTHER INFORMATION.

JOB NAME: \_\_\_\_\_  
DATE: 01/2019 JDM

# REVERSE

THIS DRAWING HAS BEEN FULLY REVERSED PLEASE VERIFY ORIENTATION



## REAR ELEVATION

SCALE: 1/4"=1'-0"



## LEFT ELEVATION

SCALE: 1/4"=1'-0"

DISREGARD STRUCTURAL ITEMS DENOTED ON THE ARCHITECTURAL PLANS. REFER TO THE SEALED STRUCTURAL PLANS FOR ALL STRUCTURAL SPECIFICATIONS. THE STRUCTURAL PLANS WERE ENGINEERED WITH FRAMING SPECIFICATIONS PROVIDED BY THE BUILDER.

AVERY J

2,325 TOTAL SQUARE FEET

PLAN NUMBER 52214J



THESE PLANS HAVE BEEN LICENSED FOR THE CONSTRUCTION OF ONE BUILDING ONLY. UNAUTHORIZED USE OR COPYING OF THE PLANS OR THE DESIGN THEREOF, VIOLATES RIGHTS UNDER THE COPYRIGHT ACT THAT INCLUDE PENALTIES OF UP TO \$100,000 PER WORK WILLFULLY INFRINGED. THESE PLANS HAVE BEEN PREPARED TO MEET IRC BUILDING CODES AND MAY REQUIRE ADAPTATION TO MEET SPECIFIC SITE CONDITIONS AND LOCAL BUILDING REGULATIONS. IT IS THE CONTRACTOR'S SOLE RESPONSIBILITY TO VERIFY ALL DIMENSIONS AND DETAILS PRIOR TO CONSTRUCTION FOR ERRORS AND OMISSIONS. PLEASE SEE YOUR LICENSE AGREEMENT FOR FURTHER INFORMATION.

JOB NAME: \_\_\_\_\_  
DATE: 01/2019 JDM

2

**REVERSE**

THIS DRAWING HAS BEEN FULLY REVERSED PLEASE VERIFY ORIENTATION

**AVERY J**

PLAN NUMBER 52214J

2,325 TOTAL SQUARE FEET

**Sintel**  
DESIGN INC.  
16865 Boones Ferry Road, Suite 201, Lake Oswego, Oregon 97035  
Tel: (503) 624 0555 • Fax: (503) 624 0155  
www.sinteldesign.com

THESE PLANS HAVE BEEN LICENSED FOR THE CONSTRUCTION OF ONE BUILDING ONLY. UNAUTHORIZED USE OR COPYING OF THE PLANS OR THE DESIGN THE DEPICT, VIOLATES RIGHTS UNDER THE COPYRIGHT ACT THAT INCLUDE PENALTIES OF UP TO \$100,000 PER WORK WILLFULLY INFRINGED. THESE PLANS HAVE BEEN PREPARED TO MEET IRC BUILDING CODES AND MAY REQUIRE ADAPTATION TO MEET SPECIFIC SITE CONDITIONS AND LOCAL BUILDING REGULATIONS. IT IS THE CONTRACTOR'S SOLE RESPONSIBILITY TO VERIFY ALL DIMENSIONS AND DETAILS PRIOR TO CONSTRUCTION FOR ERRORS AND OMISSIONS. PLEASE SEE YOUR LICENSE AGREEMENT FOR FURTHER INFORMATION.

JOB NAME: \_\_\_\_\_  
DATE: 01/2019 JDM

**3**

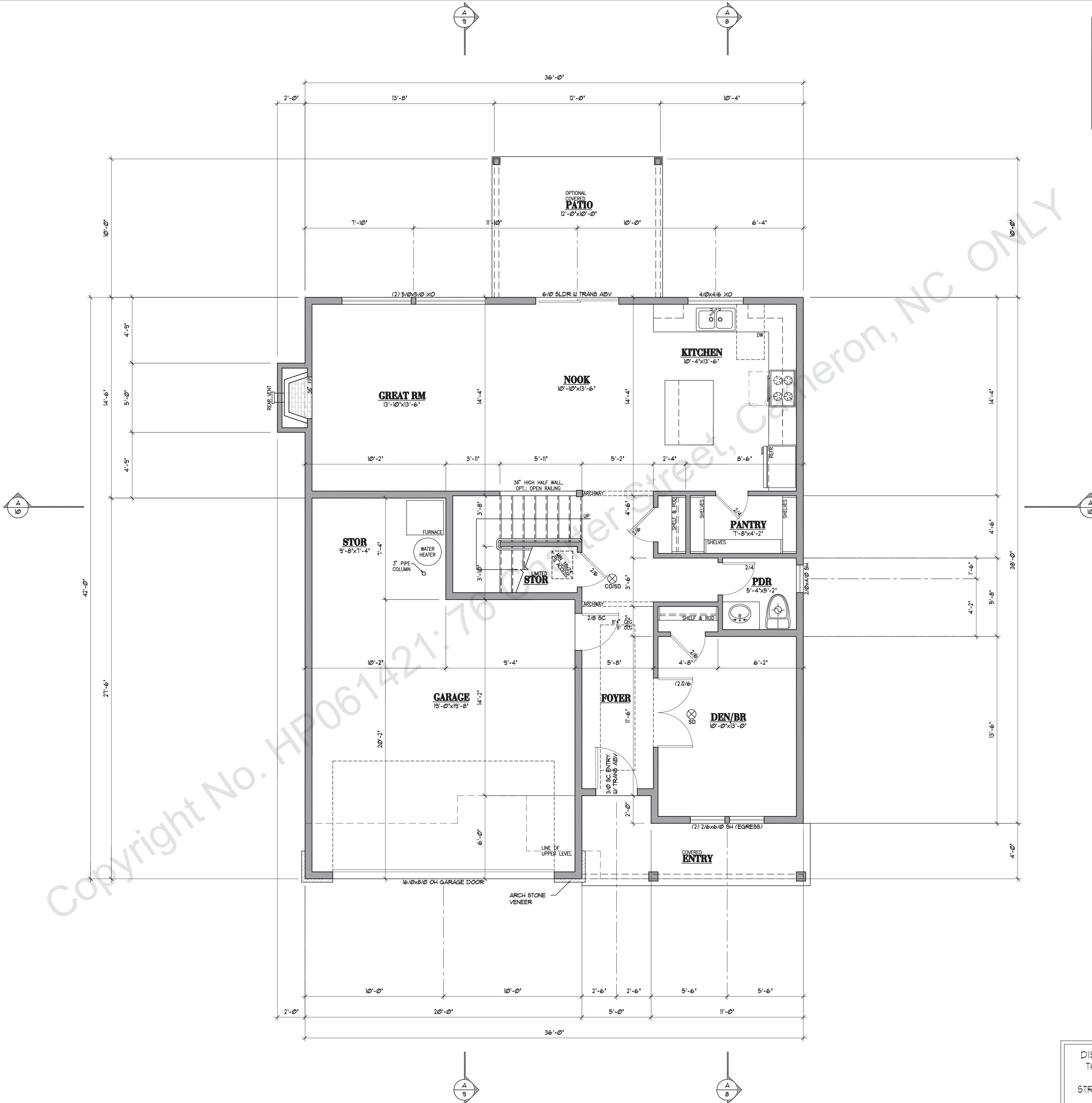

**MAIN LEVEL FLOOR PLAN**  
SCALE: 1/4"=1'-0" 967 SQ. FT.

DISREGARD STRUCTURAL ITEMS DENOTED ON THE ARCHITECTURAL PLANS. REFER TO THE SEALED STRUCTURAL PLANS FOR ALL STRUCTURAL SPECIFICATIONS. THE STRUCTURAL PLANS WERE ENGINEERED WITH FRAMING SPECIFICATIONS PROVIDED BY THE BUILDER



**REVERSE**  
 THIS DRAWING HAS BEEN FULLY REVERSED  
 PLEASE VERIFY ORIENTATION

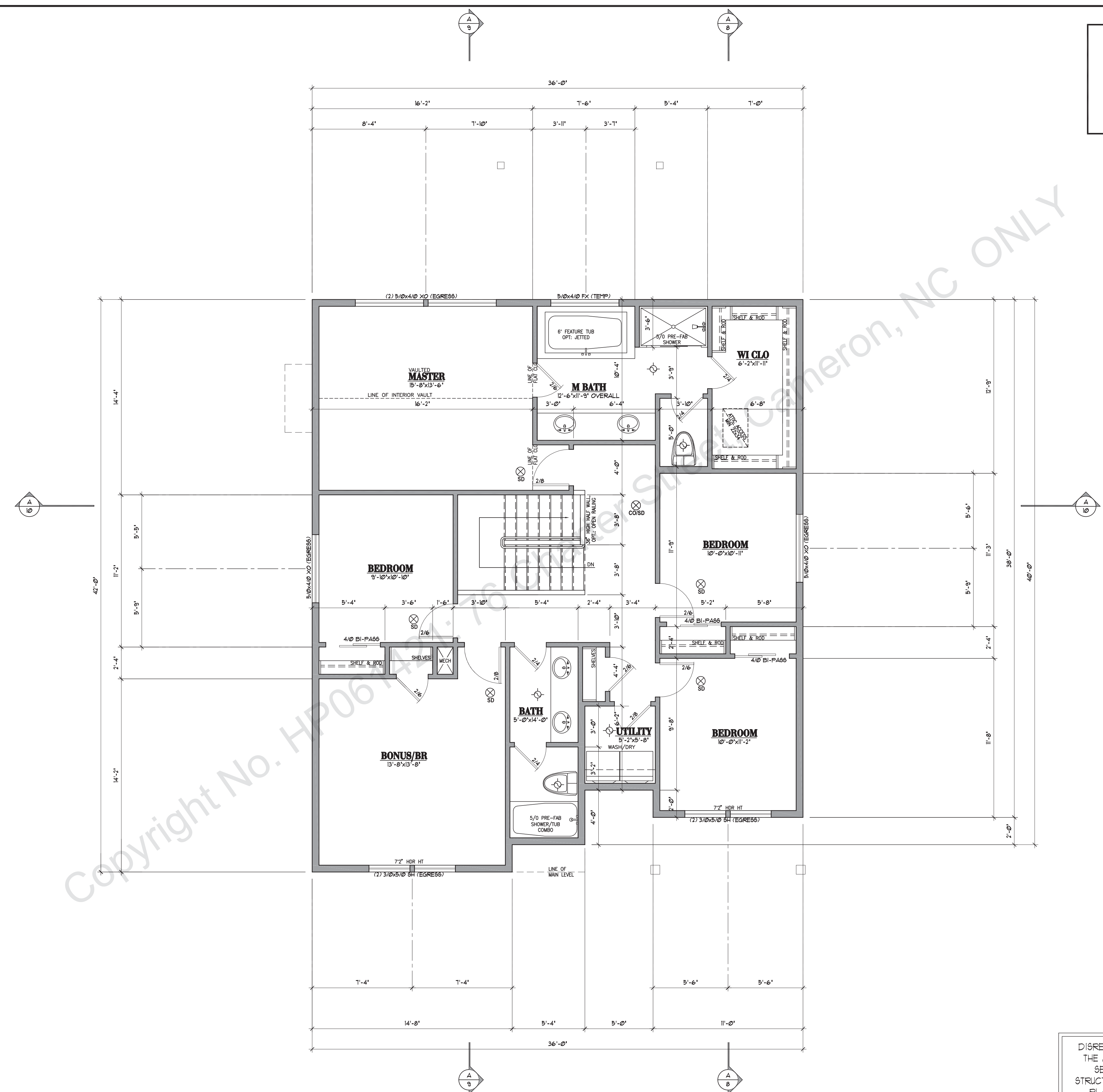

**UPPER LEVEL FLOOR PLAN**  
 SCALE: 1/4"=1'-0" 1,325 SQ. FT.

DISREGARD STRUCTURAL ITEMS DENOTED ON THE ARCHITECTURAL PLANS. REFER TO THE SEALED STRUCTURAL PLANS FOR ALL STRUCTURAL SPECIFICATIONS. THE STRUCTURAL PLANS WERE ENGINEERED WITH FRAMING SPECIFICATIONS PROVIDED BY THE BUILDER.

**AVERY J**

PLAN NUMBER 52214J

2,325 TOTAL SQUARE FEET

**Suntec**  
 DESIGN INC.  
 16865 Boones Ferry Road, Suite 201, Lake Oswego, Oregon 97035  
 Tel: (503) 624 0555-Fax: (503) 624 0155  
 www.suntecinteriordesign.com

THESE PLANS HAVE BEEN LICENSED FOR THE CONSTRUCTION OF ONE BUILDING ONLY. UNAUTHORIZED USE OR COPYING OF THE PLANS, OR THE DESIGN THEY DEPICT, INFRINGES RIGHTS UNDER THE COPYRIGHT ACT THAT INCLUDE PENALTIES OF UP TO \$100,000 PER WORK WILLFULLY INFRINGED. THESE PLANS HAVE BEEN PREPARED TO MEET IRC BUILDING CODES AND MAY REQUIRE ADAPTATION TO MEET SPECIFIC SITE CONDITIONS AND LOCAL BUILDING REGULATIONS. IT IS THE CONTRACTOR'S SOLE RESPONSIBILITY TO VERIFY ALL DIMENSIONS AND DETAILS PRIOR TO CONSTRUCTION FOR ERRORS AND OMISSIONS. PLEASE SEE YOUR LICENSE AGREEMENT FOR FURTHER INFORMATION.

JOB NAME: \_\_\_\_\_  
 DATE: 01/2019 JDM

**4**



# REVERSE

THIS DRAWING HAS BEEN FULLY REVERSED PLEASE VERIFY ORIENTATION

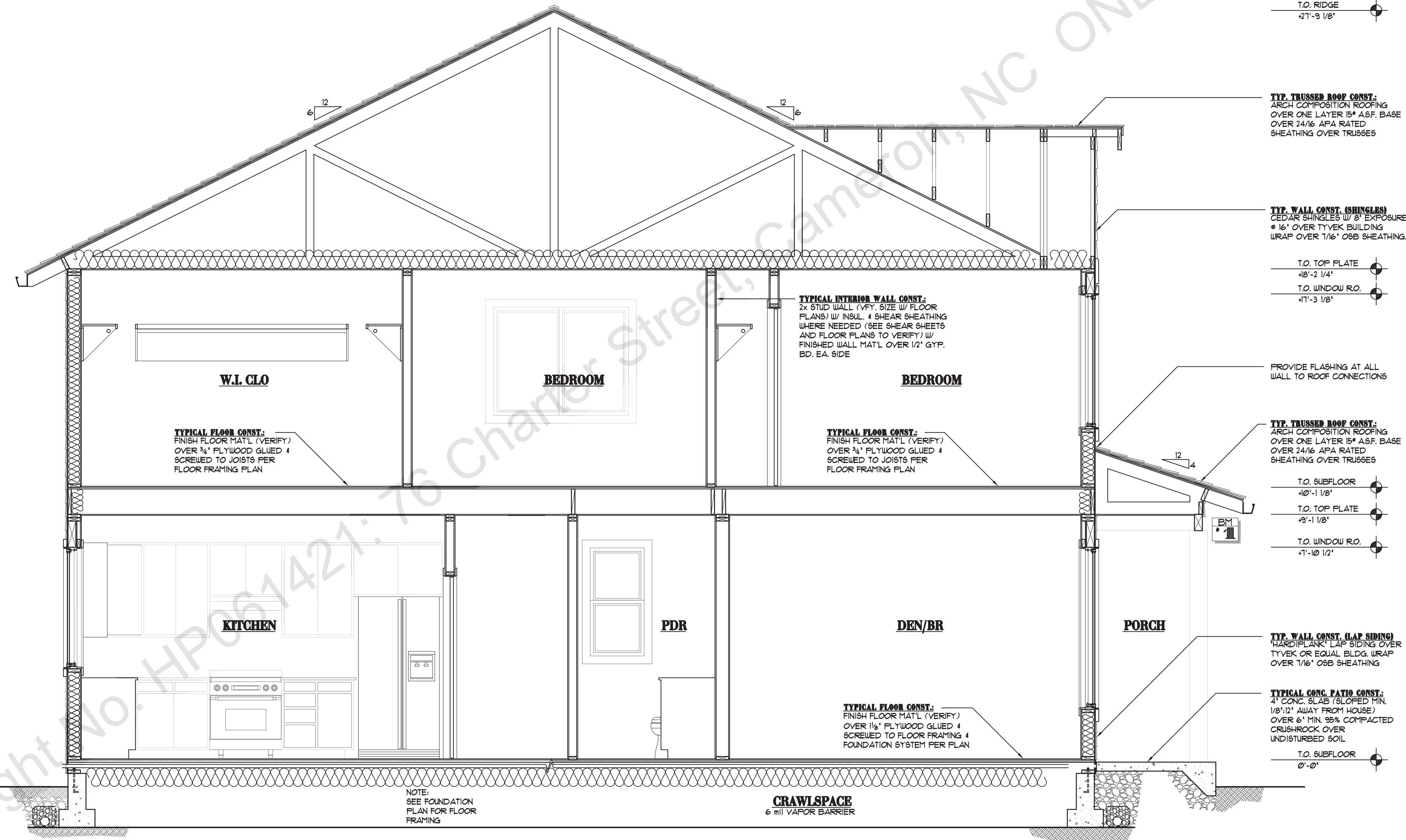

**A SECTION**  
SCALE: 3/8"=1'-0"

DISREGARD STRUCTURAL ITEMS DENOTED ON THE ARCHITECTURAL PLANS. REFER TO THE SEALED STRUCTURAL PLANS FOR ALL STRUCTURAL SPECIFICATIONS. THE STRUCTURAL PLANS WERE ENGINEERED WITH FRAMING SPECIFICATIONS PROVIDED BY THE BUILDER

2,325 TOTAL SQUARE FEET

PLAN NUMBER 52214J

**Sintel**  
DESIGN INC.  
16865 Boones Ferry Road, Suite 201, Lake Oswego, Oregon 97035  
Tel: (503) 624 0555 • Fax: (503) 624 0155  
www.sinteldesign.com

THESE PLANS HAVE BEEN LICENSED FOR THE CONSTRUCTION OF ONE BUILDING ONLY. UNAUTHORIZED USE OR COPYING OF THE PLANS OR THE DESIGN THEREOF, VIOLATES RIGHTS UNDER THE COPYRIGHT ACT THAT INCLUDE PENALTIES OF UP TO \$100,000 PER WORK WILLFULLY INFRINGED. THESE PLANS HAVE BEEN PREPARED TO MEET IRC BUILDING CODES AND MAY REQUIRE ADAPTATION TO MEET SPECIFIC SITE CONDITIONS AND LOCAL BUILDING REGULATIONS. IT IS THE CONTRACTOR'S SOLE RESPONSIBILITY TO VERIFY ALL DIMENSIONS AND DETAILS PRIOR TO CONSTRUCTION FOR ERRORS AND OMISSIONS. PLEASE SEE YOUR LICENSE AGREEMENT FOR FURTHER INFORMATION.

JOB NAME: \_\_\_\_\_  
DATE: 01/2019 JDM

8

**REVERSE**

THIS DRAWING HAS BEEN FULLY REVERSED PLEASE VERIFY ORIENTATION

**AVERY J**

2,325 TOTAL SQUARE FEET

PLAN NUMBER 52214J

**Sintel**  
DESIGN INC.  
16865 Boones Ferry Road, Suite 201, Lake Oswego, Oregon 97035  
Tel: (503) 624 0555 • Fax: (503) 624 0155  
www.sinteldesign.com

THESE PLANS HAVE BEEN LICENSED FOR THE CONSTRUCTION OF ONE BUILDING ONLY. UNAUTHORIZED USE OR COPYING OF THE PLANS OR THE DESIGN THEREOF, VIOLATES RIGHTS UNDER THE COPYRIGHT ACT THAT INCLUDE PENALTIES OF UP TO \$100,000 PER WORK WILLFULLY INFRINGED. THESE PLANS HAVE BEEN PREPARED TO MEET IRC BUILDING CODES AND MAY REQUIRE ADAPTATION TO MEET SPECIFIC SITE CONDITIONS AND LOCAL BUILDING REGULATIONS. IT IS THE CONTRACTOR'S SOLE RESPONSIBILITY TO VERIFY ALL DIMENSIONS AND DETAILS PRIOR TO CONSTRUCTION FOR ERRORS AND OMISSIONS. PLEASE SEE YOUR LICENSE AGREEMENT FOR FURTHER INFORMATION.

JOB NAME: \_\_\_\_\_  
DATE: 01/2019 JDM

**9**

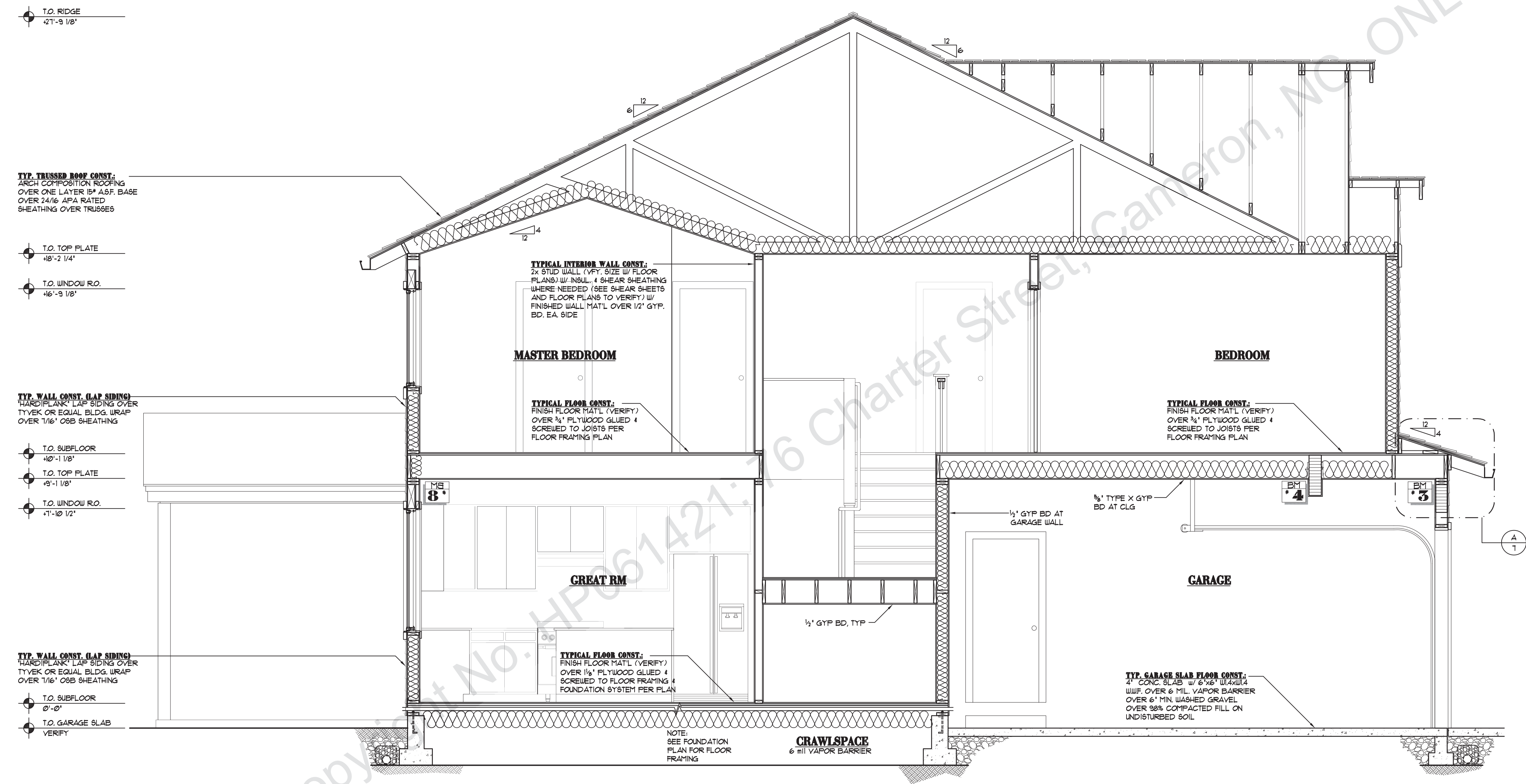

**A SECTION**  
9 SCALE: 3/8"=1'-0"

DISREGARD STRUCTURAL ITEMS DENOTED ON THE ARCHITECTURAL PLANS. REFER TO THE SEALED STRUCTURAL PLANS FOR ALL STRUCTURAL SPECIFICATIONS. THE STRUCTURAL PLANS WERE ENGINEERED WITH FRAMING SPECIFICATIONS PROVIDED BY THE BUILDER.



**REVERSE**

THIS DRAWING HAS BEEN  
FULLY REVERSED  
PLEASE VERIFY  
ORIENTATION

**AVERY J**

PLAN NUMBER 52214J

2,325 TOTAL SQUARE FEET

**Sintel**  
DESIGN INC.  
16865 Boones Ferry Road, Suite 201, Lake Oswego, Oregon 97035  
Tel: (503) 624 0555 • Fax: (503) 624 0155  
www.sinteldesign.com

THESE PLANS HAVE BEEN LICENSED FOR THE CONSTRUCTION OF ONE BUILDING ONLY. UNAUTHORIZED USE OR COPYING OF THE PLANS OR THE DESIGN THEREOF, VIOLATES RIGHTS UNDER THE COPYRIGHT ACT THAT INCLUDE PENALTIES OF UP TO \$100,000 PER WORK WILLFULLY INFRINGED. THESE PLANS HAVE BEEN PREPARED TO MEET IRC BUILDING CODES AND MAY REQUIRE ADAPTATION TO MEET SPECIFIC SITE CONDITIONS AND LOCAL BUILDING REGULATIONS. IT IS THE CONTRACTOR'S SOLE RESPONSIBILITY TO VERIFY ALL DIMENSIONS AND DETAILS PRIOR TO CONSTRUCTION FOR ERRORS AND OMISSIONS. PLEASE SEE YOUR LICENSE AGREEMENT FOR FURTHER INFORMATION.

JOB NAME: \_\_\_\_\_  
DATE: 01/2019 JDM

**10**

**TYP. TRUSSED ROOF CONST.:**  
ARCH COMPOSITION ROOFING  
OVER ONE LAYER 1/4" ASF. BASE  
OVER 24/16 APA RATED  
SHEATHING OVER TRUSSES

T.O. TOP FLATE  
+8'-2 1/4"  
T.O. WINDOW R.O.  
+6'-9 1/8"

**TYP. WALL CONST. (LAP SIDING):**  
HARD PLANK LAP SIDING OVER  
TYVEK OR EQUAL BLDG. WRAP  
OVER 1/8" OSB SHEATHING

T.O. SUBFLOOR  
+0'-1 1/8"  
T.O. TOP FLATE  
+9'-1 1/8"

T.O. SUBFLOOR  
0'-0"  
T.O. GARAGE SLAB  
VERIFY

**BEDROOM**

**BEDROOM**

**STORAGE**

**PANTRY**

**TYP. GARAGE SLAB FLOOR CONST.:**  
4" CONC. SLAB w/ 6"x6" W/4x4  
W/UF. OVER 6 MIL. VAPOR BARRIER  
OVER 6" MIN. WASHED GRAVEL  
OVER 88% COMPACTED FILL ON  
UNDISTURBED SOIL

**TYPICAL INTERIOR WALL CONST.:**  
2x STUD WALL (V.FY. SIZE w/ FLOOR  
PLANS) w/ INSUL. 4 SHEAR SHEATHING  
WHERE NEEDED (SEE SHEAR SHEETS  
AND FLOOR PLANS TO VERIFY) w/  
FINISHED WALL MATL. OVER 1/2" GYP.  
BD. EA. SIDE

**TYPICAL FLOOR CONST.:**  
FINISH FLOOR MATL. (VERIFY)  
OVER 3/4" PLYWOOD GLUED 4  
SCREWED TO JOISTS PER  
FLOOR FRAMING PLAN

**TYPICAL FLOOR CONST.:**  
FINISH FLOOR MATL. (VERIFY)  
OVER 3/4" PLYWOOD GLUED 4  
SCREWED TO FLOOR FRAMING 4  
FOUNDATION SYSTEM PER PLAN

NOTE:  
SEE FOUNDATION  
PLAN FOR FLOOR  
FRAMING

**CRAWLSPACE**  
6 mil VAPOR BARRIER

**A SECTION**  
10 SCALE: 3/8"=1'-0"

DISREGARD STRUCTURAL ITEMS DENOTED ON  
THE ARCHITECTURAL PLANS. REFER TO THE  
SEALED STRUCTURAL PLANS FOR ALL  
STRUCTURAL SPECIFICATIONS. THE STRUCTURAL  
PLANS WERE ENGINEERED WITH FRAMING  
SPECIFICATIONS PROVIDED BY THE BUILDER.



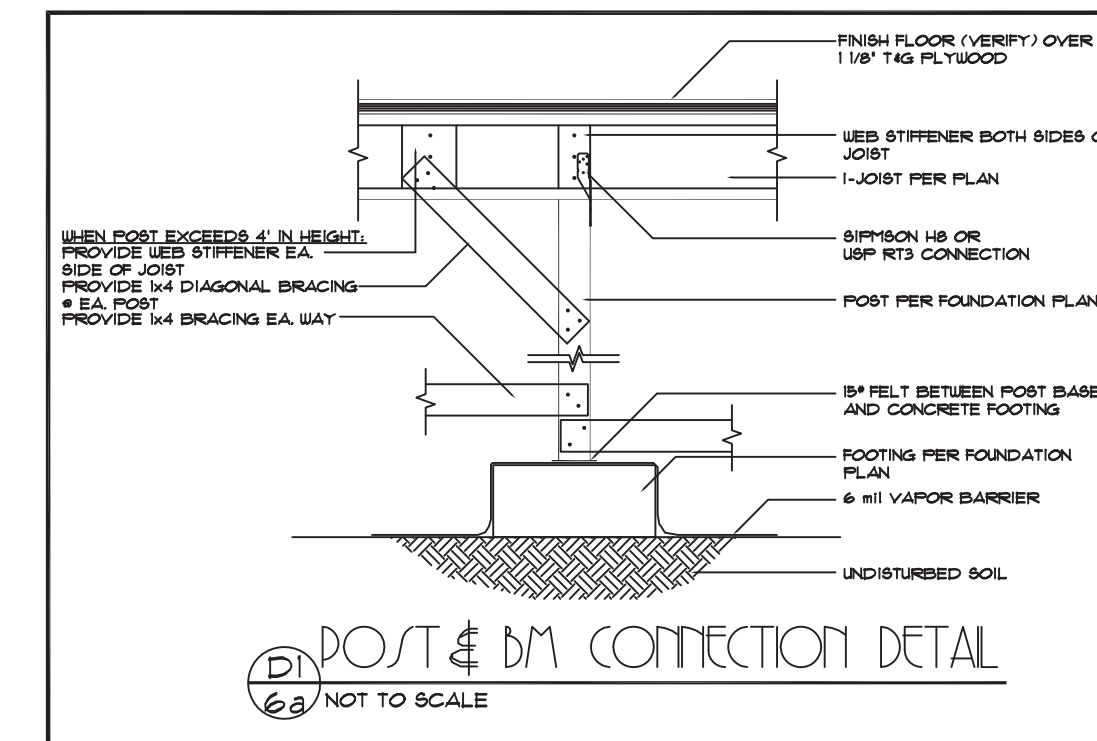
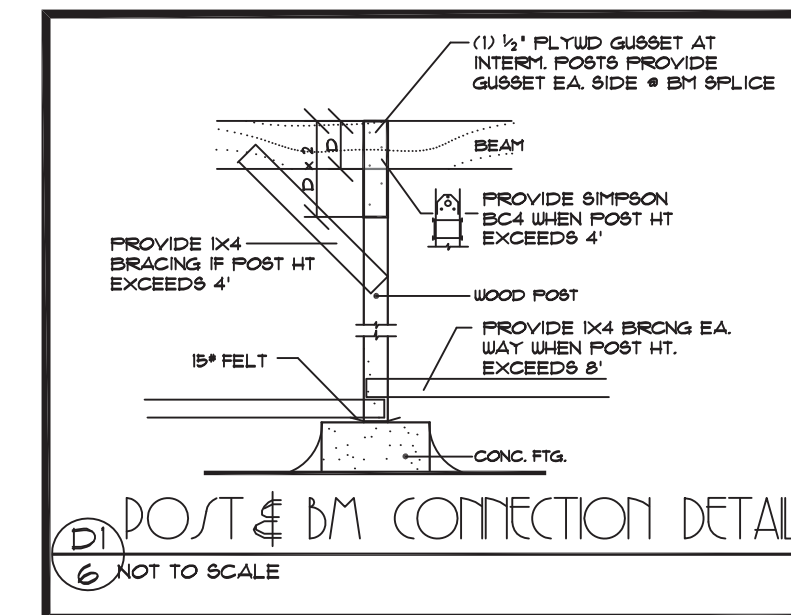
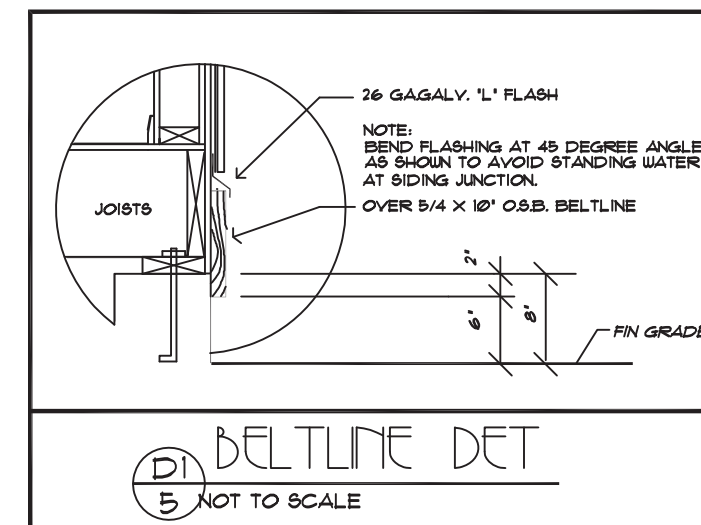
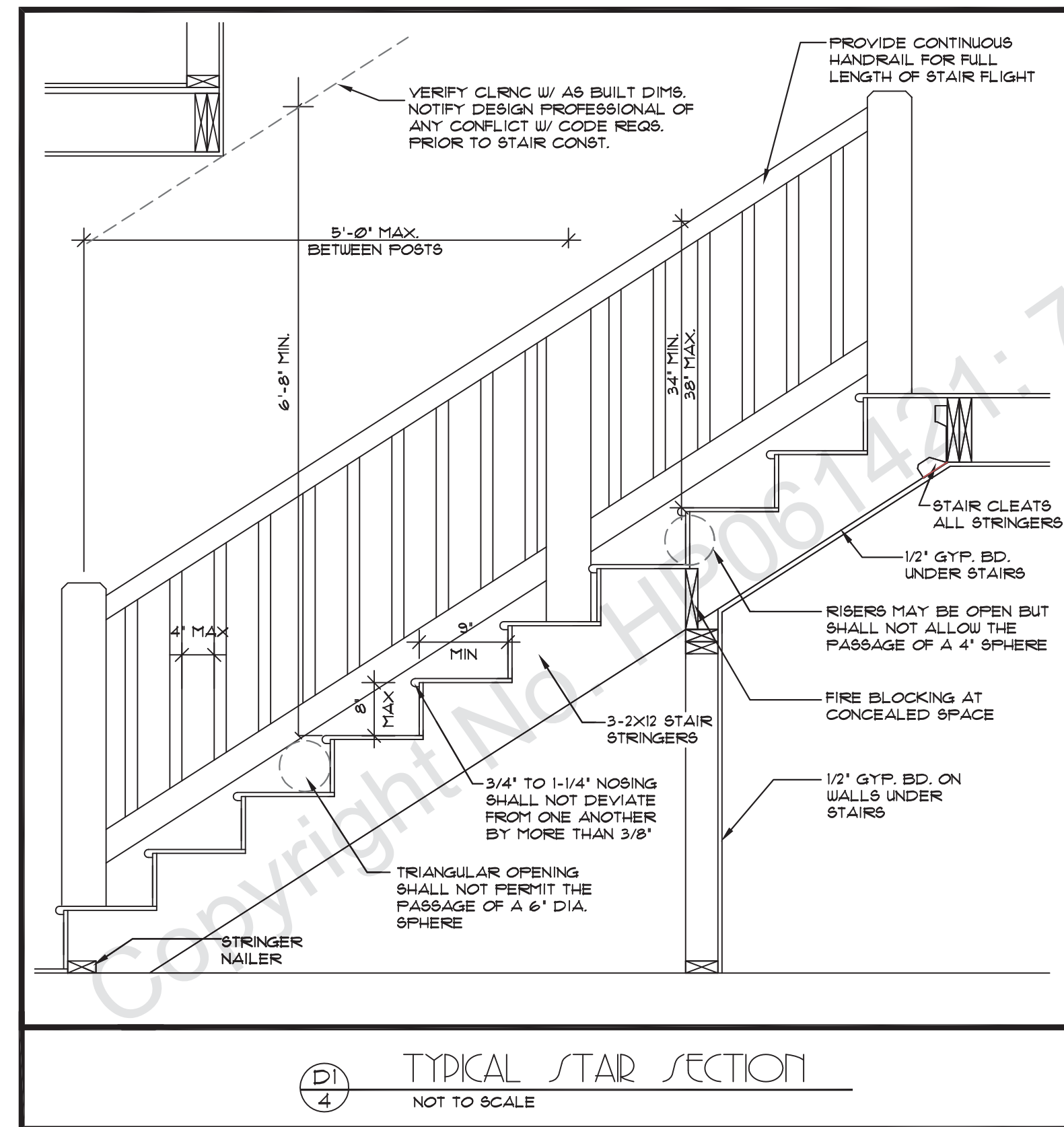
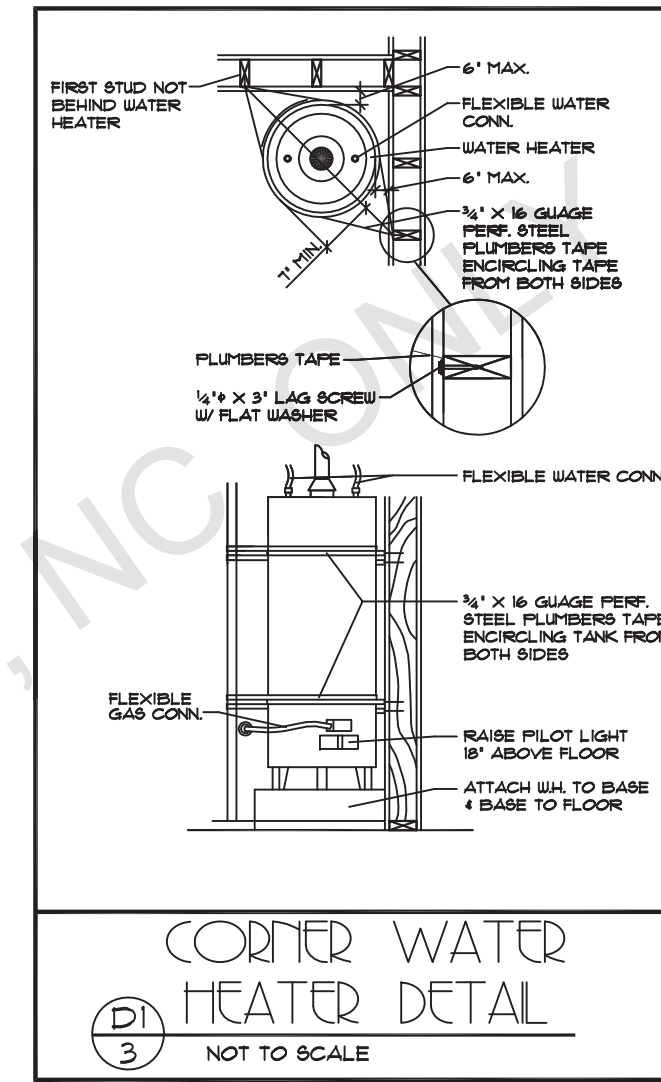
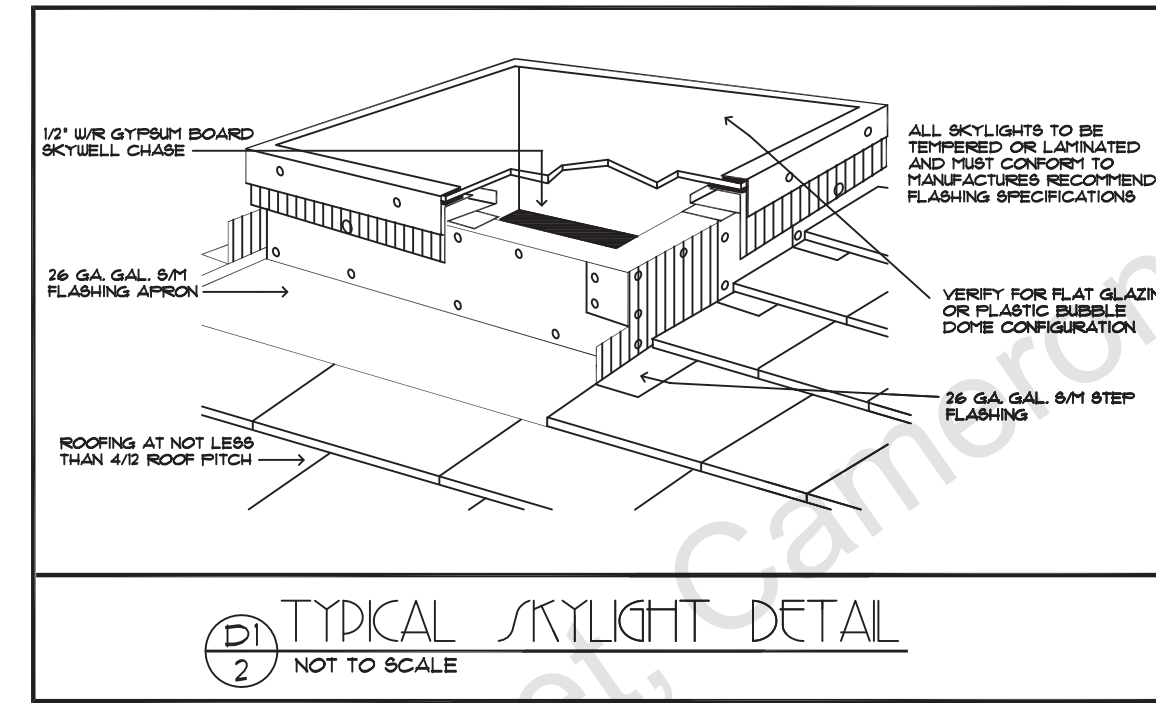
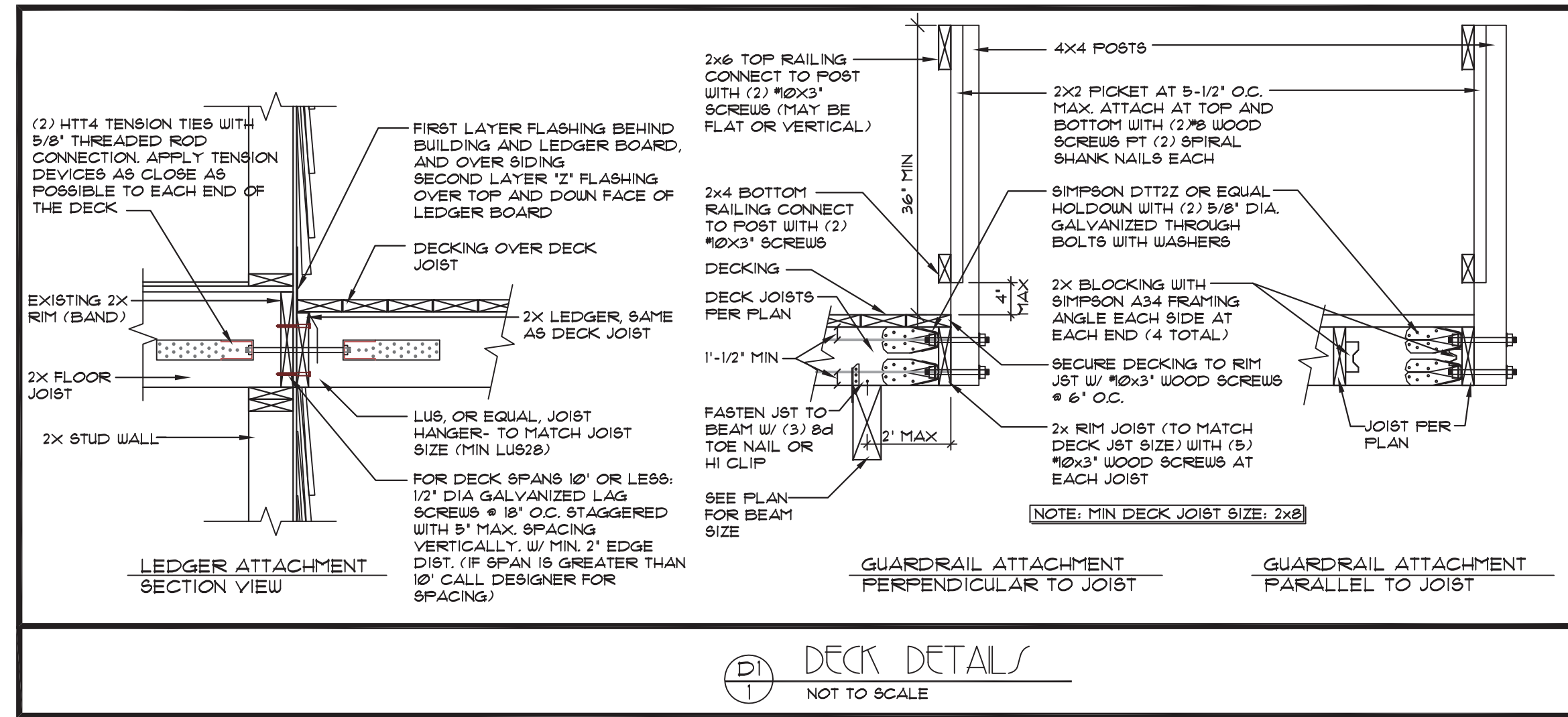

DISREGARD STRUCTURAL ITEMS DENOTED ON THE ARCHITECTURAL PLANS. REFER TO THE SEALED STRUCTURAL PLANS FOR ALL STRUCTURAL SPECIFICATIONS. THE STRUCTURAL PLANS WERE ENGINEERED WITH FRAMING SPECIFICATIONS PROVIDED BY THE BUILDER.

**Suntec**  
DESIGN INC.  
155 B Ave, Suite 105, Lake Oswego, Oregon 97034  
Tel: (503) 624-0555  
www.suntecdesign.com

THESE PLANS HAVE BEEN LICENSED FOR THE CONSTRUCTION OF ONE BUILDING ONLY. UNAUTHORIZED USE OR COPYING OF THE PLANS, OR THE DESIGN THEY DEPICT, INFRINGES RIGHTS UNDER THE COPYRIGHT ACT THAT INCLUDE PENALTIES OF UP TO \$100,000 PER WORK WILLFULLY INFRINGED. THESE PLANS HAVE BEEN PREPARED TO MEET CASO BUILDING CODES AND MAY REQUIRE ADAPTATION TO MEET SPECIFIC SITE CONDITIONS AND LOCAL BUILDING REGULATIONS. IT IS THE CONTRACTOR'S SOLE RESPONSIBILITY TO VERIFY ALL DIMENSIONS AND DETAILS PRIOR TO CONSTRUCTION FOR ERRORS AND OMISSIONS. PLEASE SEE YOUR LICENSE AGREEMENT FOR FURTHER INFORMATION.

SHEET: DETAILS  
DATE: 07/08

**D1**



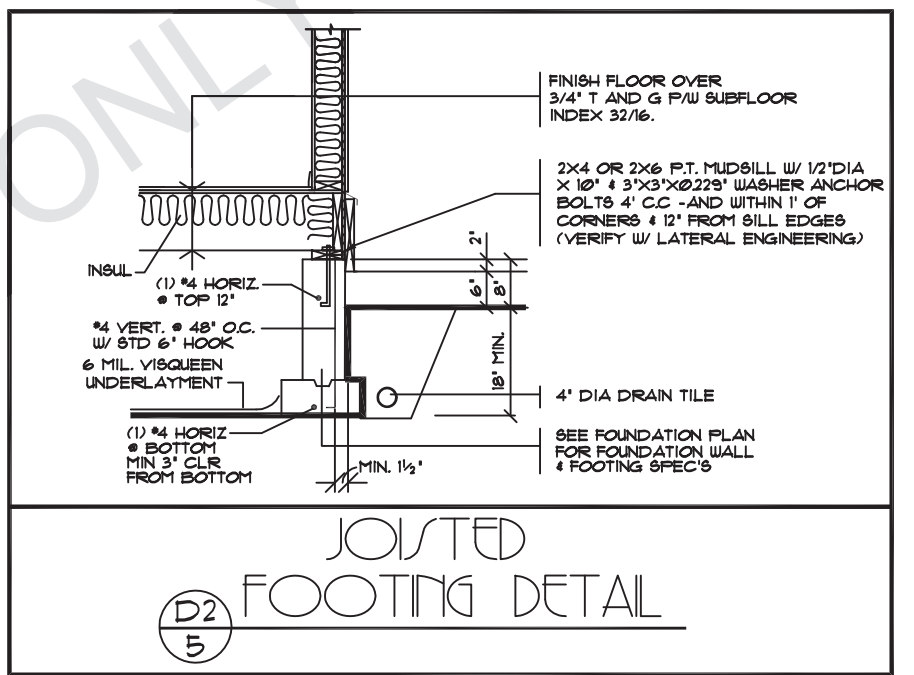
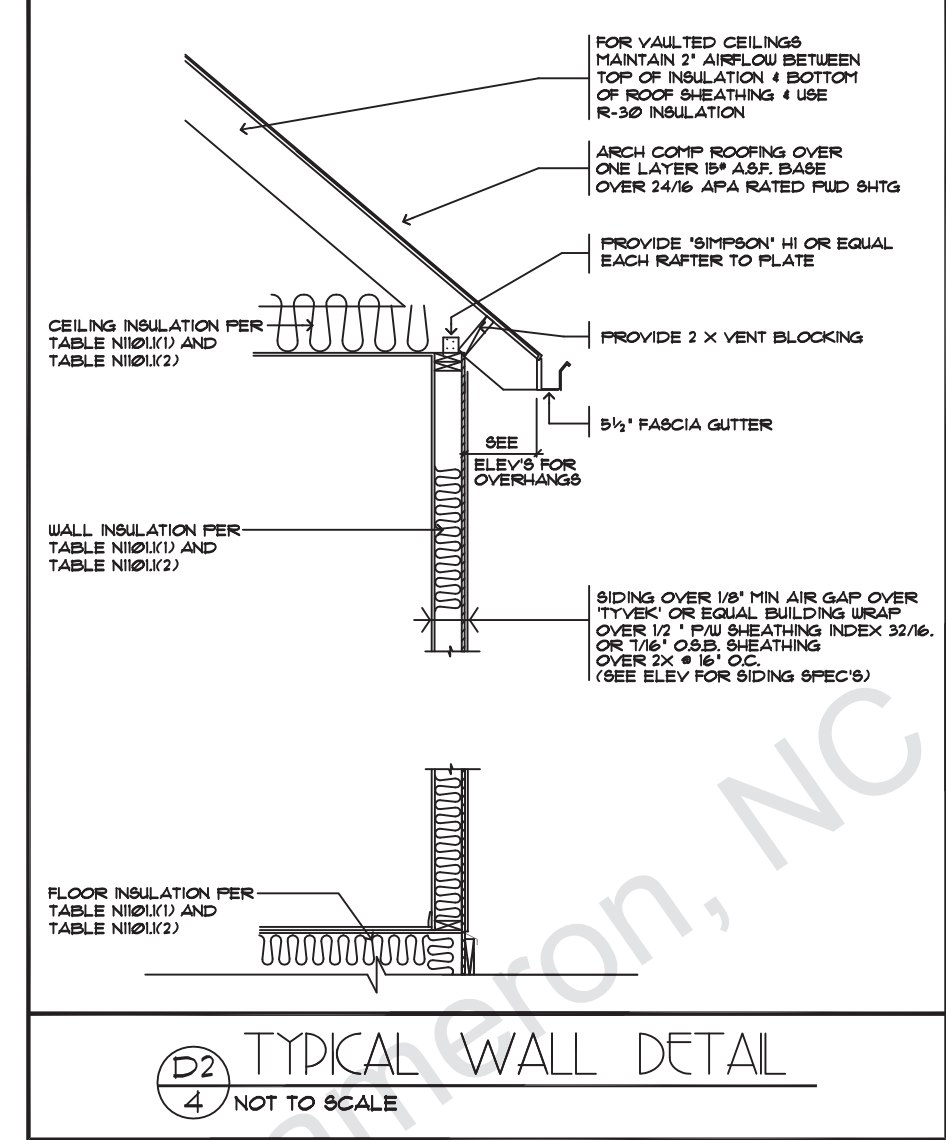
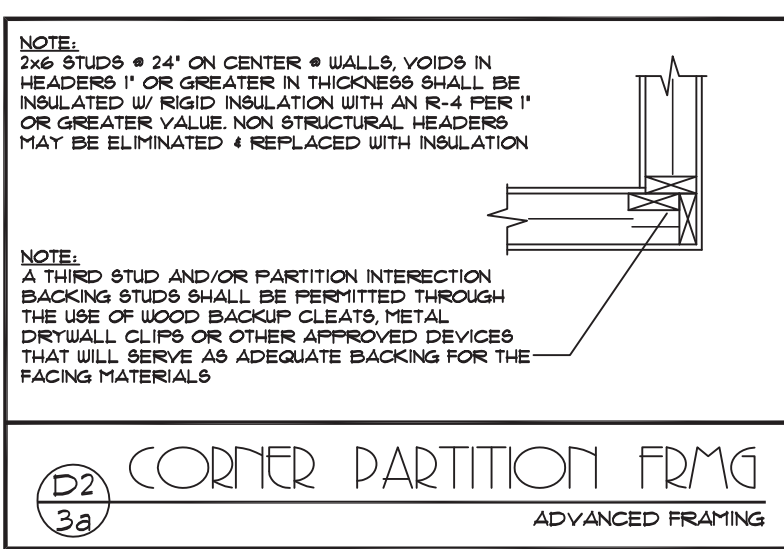
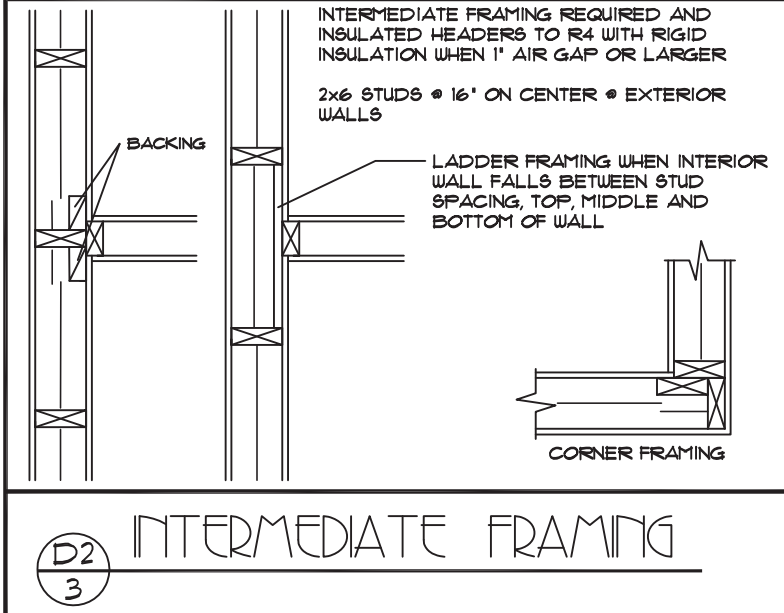
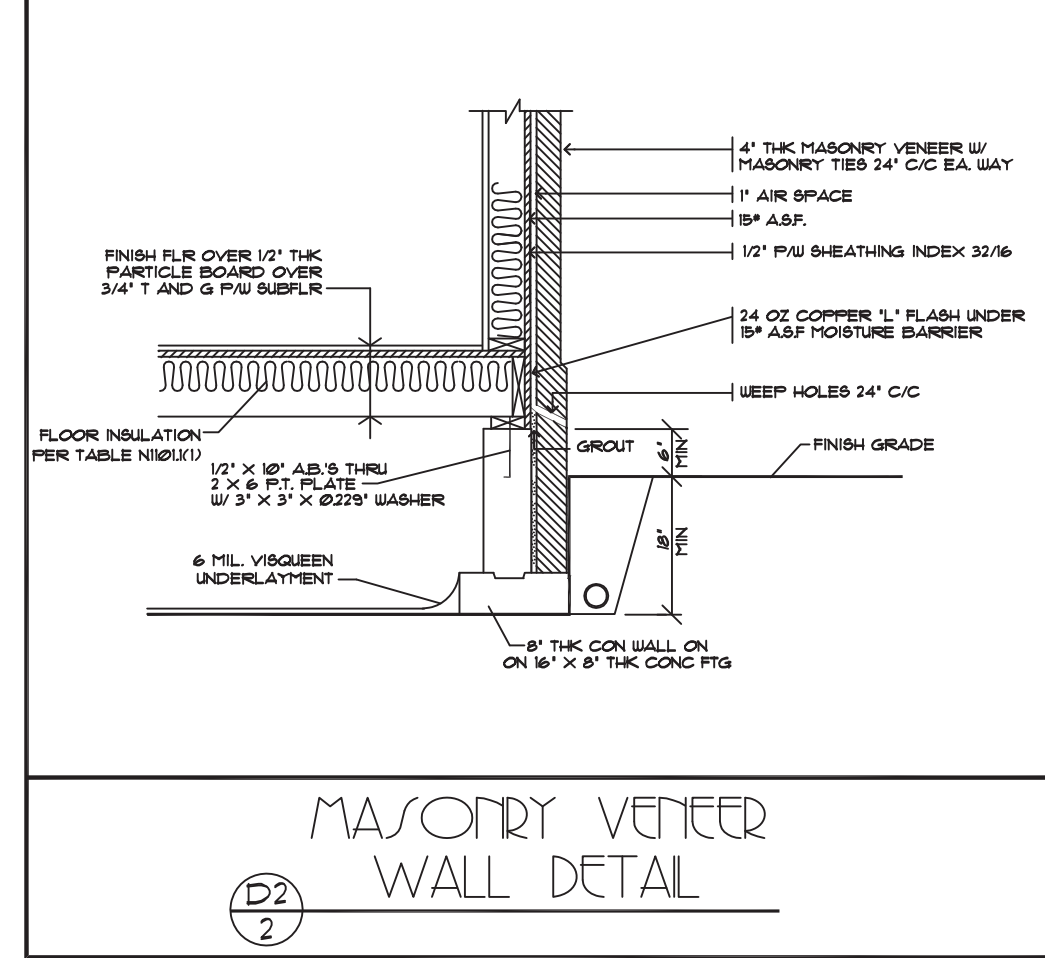
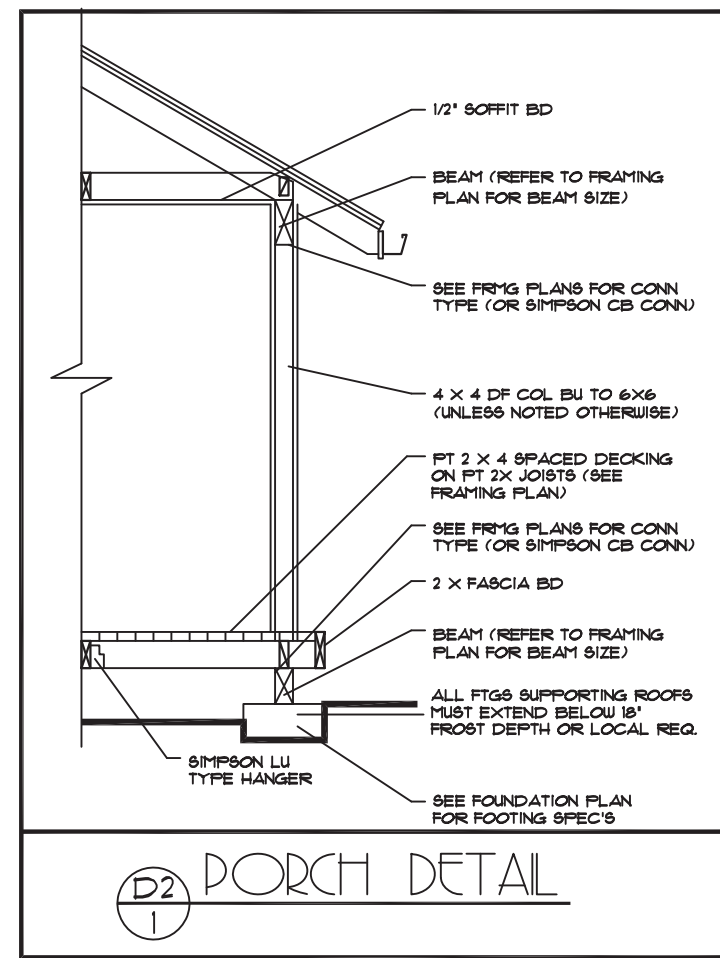

DISREGARD STRUCTURAL ITEMS DENOTED ON THE ARCHITECTURAL PLANS, REFER TO THE SEALED STRUCTURAL PLANS FOR ALL STRUCTURAL SPECIFICATIONS. THE STRUCTURAL PLANS WERE ENGINEERED WITH FRAMING SPECIFICATIONS PROVIDED BY THE BUILDER.

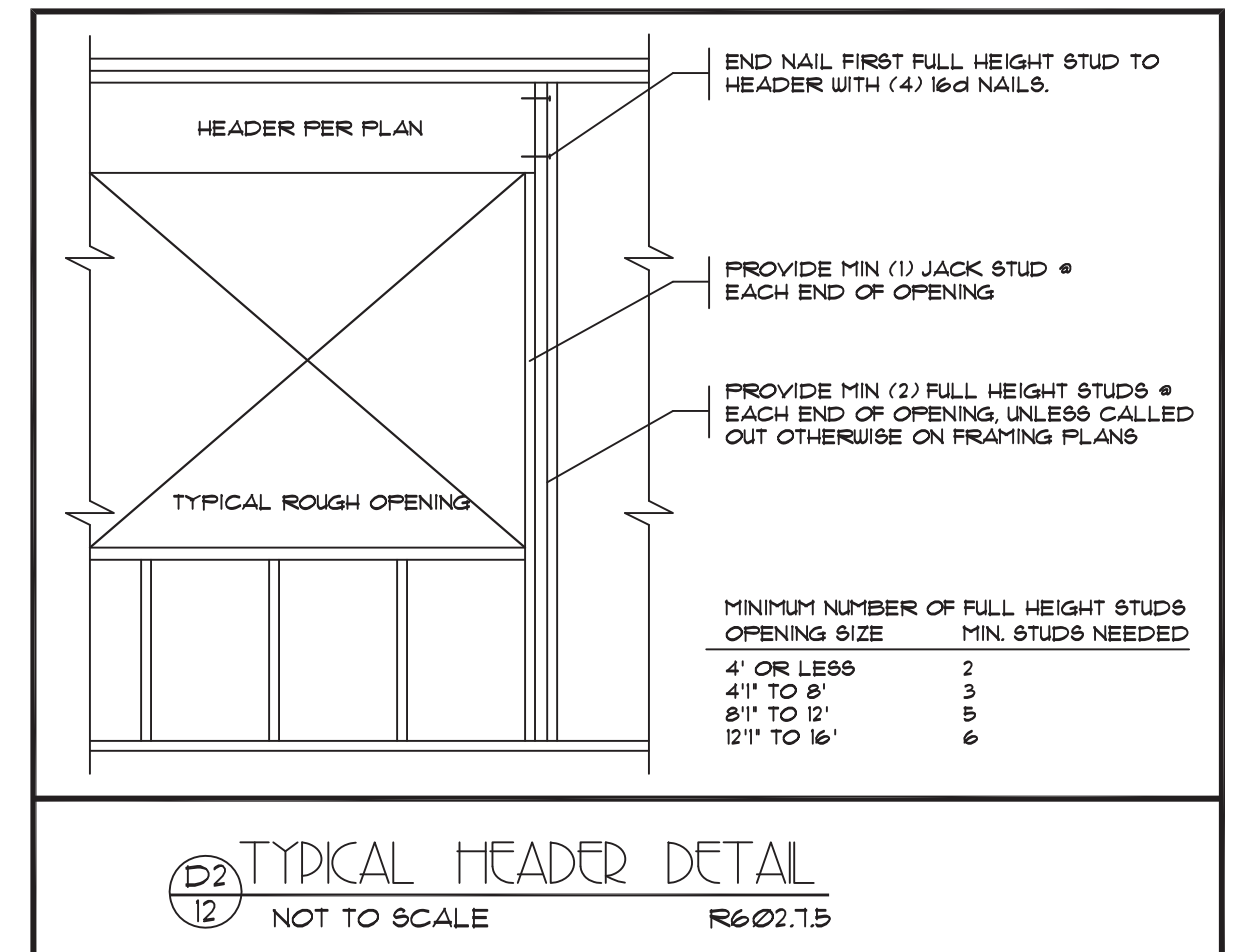
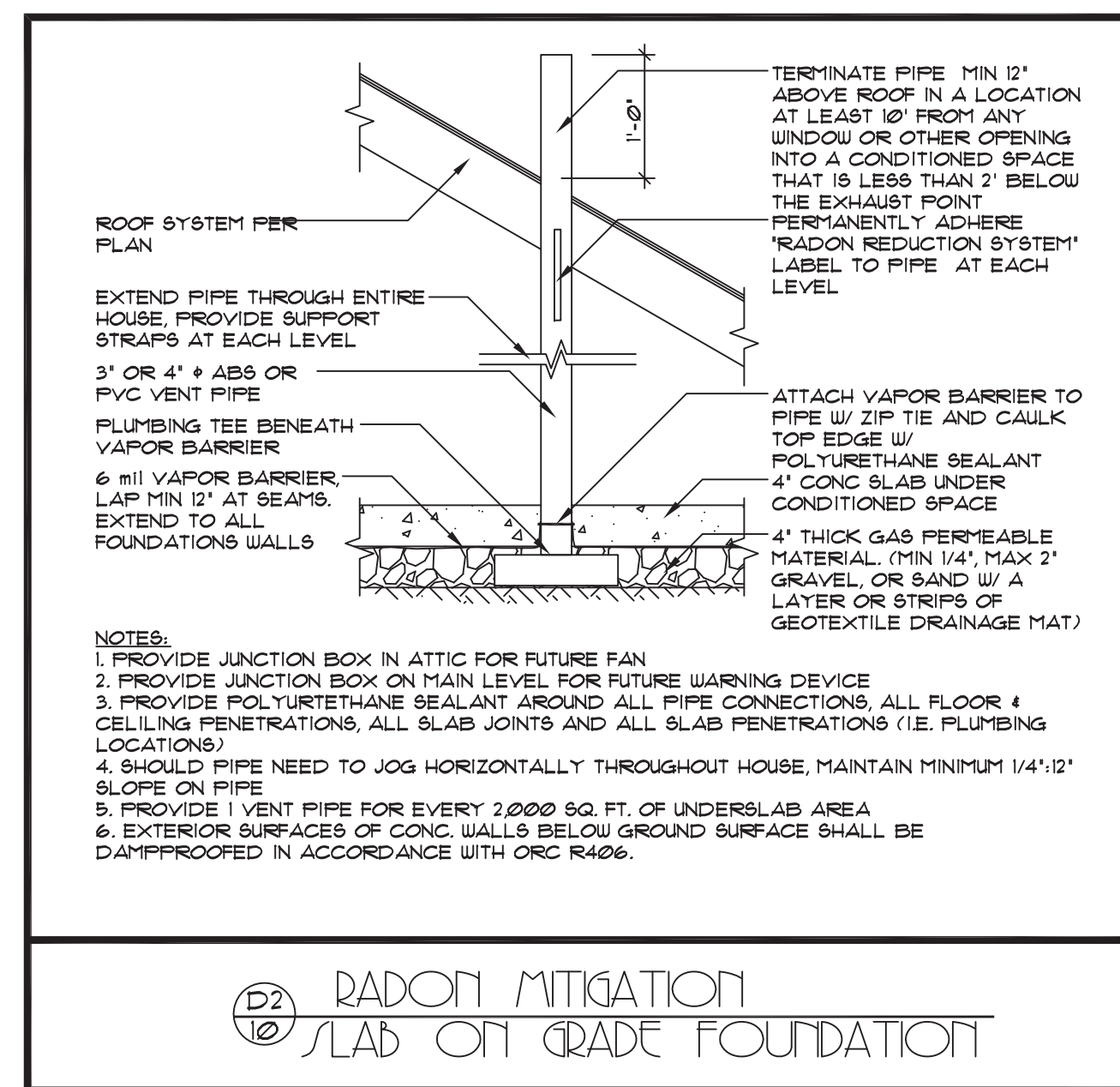
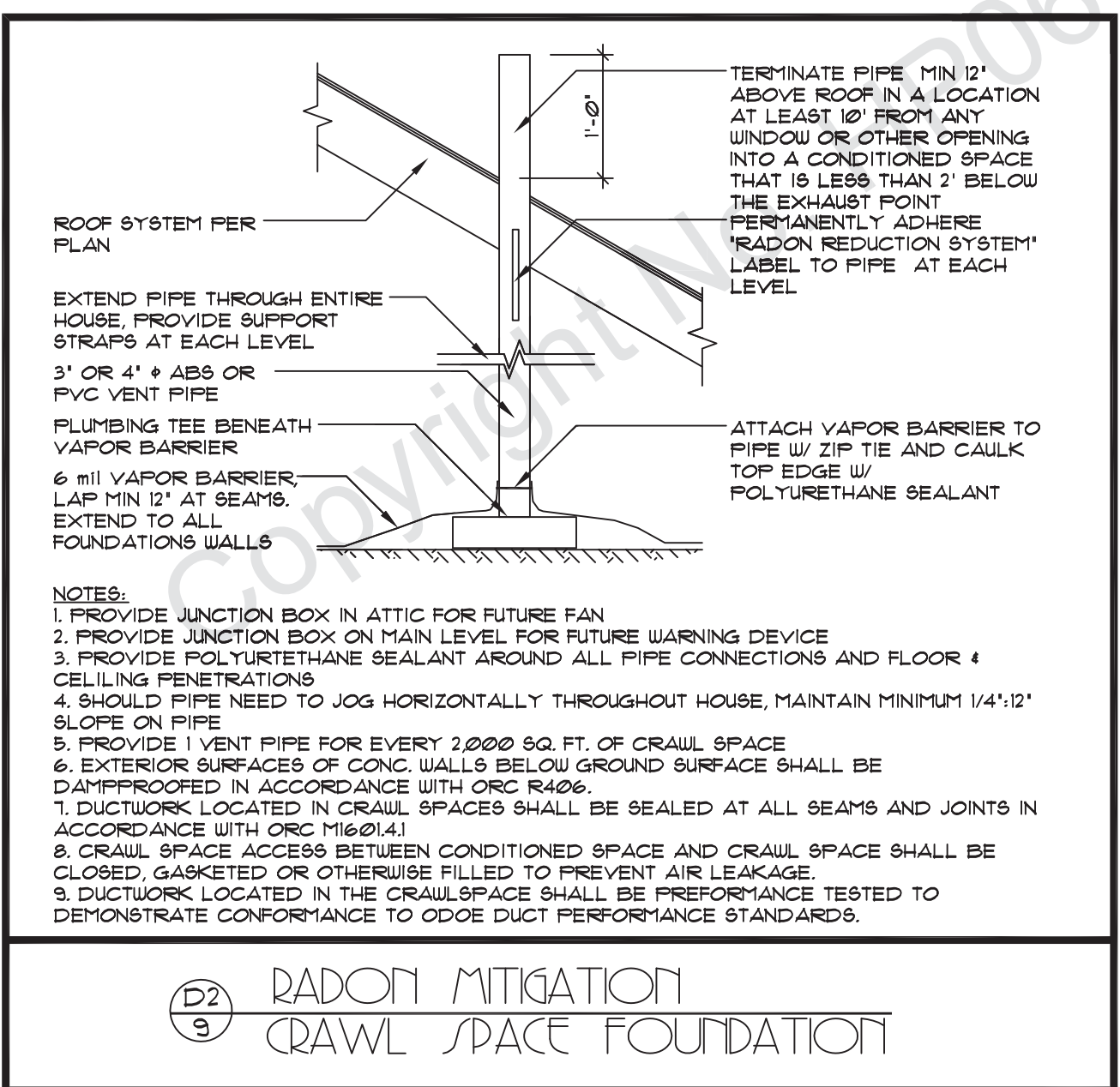
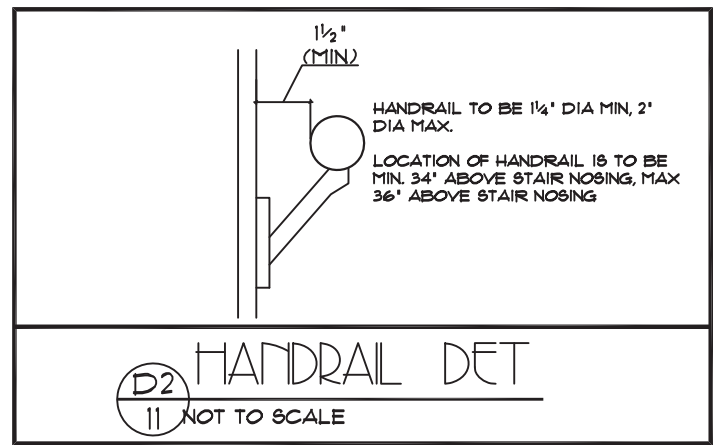
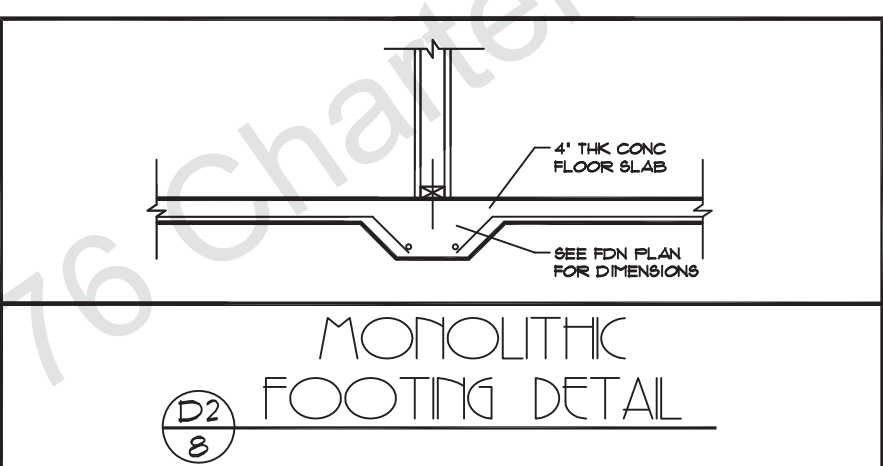
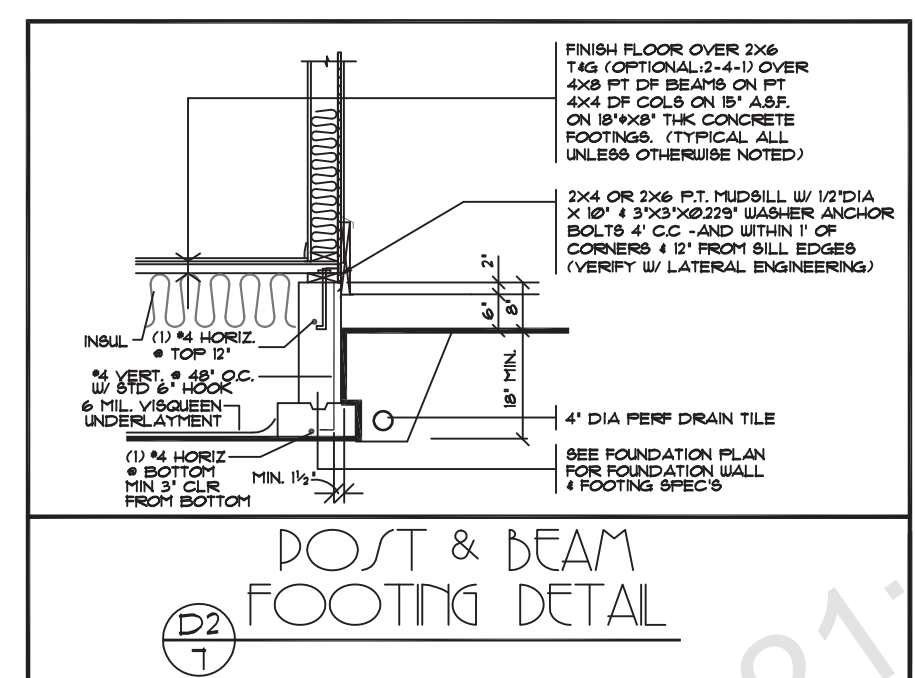
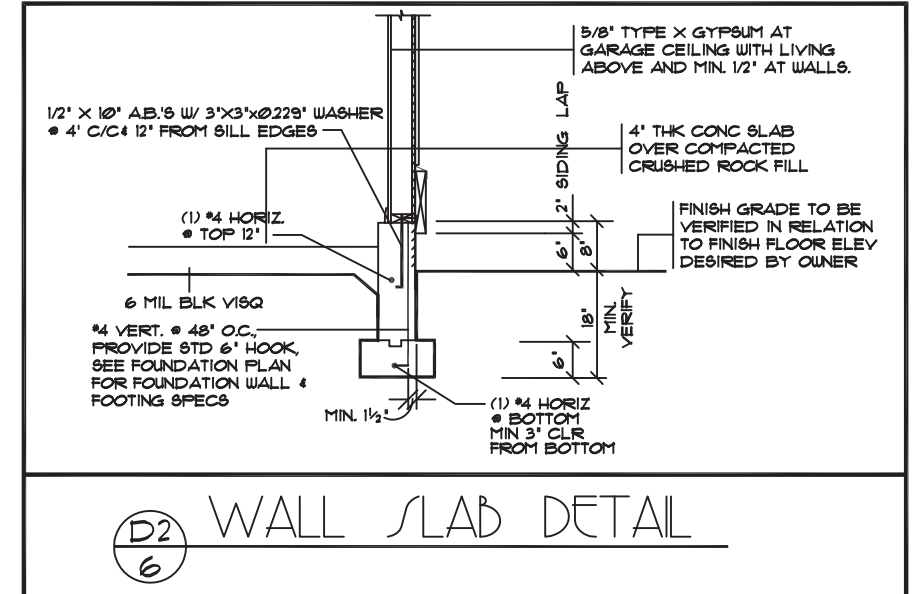

**Sunteel**  
DESIGN INC.  
WWW.SUNTEELDESIGN.COM  
Tel: (503) 624 0155 • 16865 Boones Ferry Road, Suite 103, Lake Oswego, Oregon 97035

THESE PLANS HAVE BEEN LICENSED FOR THE CONSTRUCTION OF ONE BUILDING ONLY. UNAUTHORIZED USE OR COPYING OF THESE PLANS, OR THE DESIGN THEREOF, INFRINGES RIGHTS UNDER THE COPYRIGHT ACT THAT INCLUDE PENALTIES OF UP TO \$100,000 PER WORK WILLFULLY INFRINGED. THESE PLANS HAVE BEEN PREPARED TO MEET CAROLINA BUILDING CODES AND MAY REQUIRE ADAPTATION TO MEET SPECIFIC SITE CONDITIONS AND LOCAL BUILDING REGULATIONS. IT IS THE CONTRACTOR'S SOLE RESPONSIBILITY TO VERIFY ALL DIMENSIONS AND DETAILS PRIOR TO CONSTRUCTION FOR ERRORS AND OMISSIONS. PLEASE SEE YOUR LICENSE AGREEMENT FOR FURTHER INFORMATION.

SHEET: DETAILS  
DATE: 12/2019

**D2**

DETAILS SHEET



## GENERAL NOTES

- ALL WORK IS TO COMPLY WITH THE LATEST ADOPTED VERSION OF THE ORSC CODE AND ANY APPLICABLE STATE, COUNTY OR LOCAL REGULATIONS.
- THE CONTRACTOR IS RESPONSIBLE TO CHECK THE PLANS AND IS TO NOTIFY THE DESIGNER OF ANY ERRORS OR OMISSIONS PRIOR TO THE START OF CONSTRUCTION.
- WRITTEN DIMENSIONS HAVE PRECEDENCE OVER SCALED DIMENSIONS.
- DESIGN LOADS: ROOF 30 PSF (LIVE LOAD)  
FLOOR 40 PSF (LIVE LOAD)  
STAIRS 100 PSF  
GARAGE FLOOR 25 PSF (20000' FT.)  
DECKS 75 PSF  
(IF YOUR LOCAL AREA REQUIRES DIFFERENT DESIGN LOADS, CONSULT WITH A LOCAL STRUCTURAL ENGINEER TO DETERMINE THE APPROPRIATE REVISIONS.)
- PROVIDE INSULATION BARRIERS AT EAVE VENTS BETWEEN RAFTERS.
- ALL SMOKE DETECTORS SHALL BE POWERED BY 110V CURRENT, CONNECTED TO HOUSE ELECTRICAL SYSTEM. INTERCONNECT WITH EACH ONE SO THAT IF ANY ONE TRIPS THEY WILL ALL SOUND. THEY SHALL ALSO HAVE A BATTERY BACKUP AND BE LOCATED IN EACH BEDROOM AND ON EACH FLOOR LEVEL. GUARDRAILS SHALL HAVE INTERMEDIATE RAILS SPACED SUCH THAT A SPHERE 4" IN DIA. CANNOT PASS THROUGH PROVIDE GROUNDING ELECTRODE AT ELECTRICAL SERVICE CONSISTING OF A MINIMUM 20' LENGTH OF 1/2" STEEL REINFORCEMENT OF EACH ELECTRODE SHALL EXTEND 12" MIN. ABOVE THE PLATE LINE.
- THE MAXIMUM AMOUNT OF WATER USED BY NEW PLUMBING FIXTURES: (EPA 1992 COMPLIANT)  
TOILETS 2.0 GALLONS/MINUTE  
SHOWER HEADS 2.0 GALLONS/MINUTE  
INTERIOR FAUCETS 2.0 GALLONS/MINUTE
- IN THE EVENT OF CONFLICT BETWEEN PERMITS, CODES AND REGULATIONS AND REFERENCED STANDARDS OF THESE SPECIFICATIONS, THE MORE STRINGENT PROVISIONS SHALL GOVERN REGULATIONS.
- STRUCTURAL SPECIFICATIONS AND DRAWINGS FOR THIS WORK HAVE BEEN PREPARED IN ACCORDANCE WITH GENERALLY ACCEPTED LATERAL DESIGN PRACTICE TO MEET MINIMUM REQUIREMENTS OF THE LATEST EDITION OF THE ORSC.
- SPECIFICATIONS AND DRAWINGS INDICATE FINISHED STRUCTURE. BUILDER SHALL BE RESPONSIBLE FOR CONSTRUCTION METHODS, PROCEDURES, AND CONDITIONS (INCLUDING SAFETY) EXCEPT AS SPECIFICALLY INDICATED OTHERWISE IN THE CONTRACT DOCUMENTS.
- CONSTRUCTION LOADS SHALL NOT OVERLOAD STRUCTURE NOR SHALL THEY BE IN EXCESS OF DESIGN LOADINGS INDICATED ON DRAWINGS.
- BUILDER SHALL VERIFY ALL DIMENSIONS, DIMENSIONS AND CONDITIONS SHOWN ON STRUCTURAL DRAWINGS OR NOTED IN STRUCTURAL SPECIFICATIONS. ANY VARIANCES WITHIN STRUCTURAL DRAWINGS AND SPECIFICATIONS OR WITHIN CONDITIONS ENCOUNTERED AT JOB SITE, SHALL BE REPORTED TO OWNER IN WRITING BEFORE COMMENCEMENT OF ANY WORK EFFECTED BY SUCH VARIANCE.
- BUILDER SHALL RIGIDLY ADHERE TO ALL LAWS, CODES, AND ORDINANCES WHICH APPLY TO THIS WORK. HE SHALL NOTIFY AND RECEIVE CLARIFICATION FROM OWNER IN WRITING OF ANY VARIATIONS BETWEEN CONTRACT DOCUMENTS AND GOVERNING REGULATIONS.
- ALL MANUFACTURED MATERIALS, COMPONENTS, FASTENERS, ASSEMBLIES, ETC. SHALL BE HANDLED AND INSTALLED IN ACCORDANCE WITH MANUFACTURER'S INSTRUCTIONS AND PROVISIONS OF APPLICABLE ICBO RESEARCH RECOMMENDATIONS, WHERE SPECIFIC MANUFACTURED PRODUCTS ARE CALLED FOR. GENERIC EQUALS WHICH MEET OR EXCEED ALL APPLICABLE STANDARDS AND SPECIFICATIONS MAY BE USED.
- NO VARIANCE BY A BUILDING OFFICIAL SHALL BE BINDING ON DESIGNER.
- BUILDER SHALL INVESTIGATE SITE DURING CLEARING AND EARTHWORK OPERATIONS FOR FILLED EXCAVATIONS OR BURIED STRUCTURES SUCH AS GAS MAINS, UTILITY LINES, FOUNDATIONS, ETC. IF ANY SUCH ITEMS ARE FOUND, OWNER SHALL BE NOTIFIED IMMEDIATELY.
- CARBON MONOXIDE DETECTORS SHALL BE PROVIDED IN ANY HOME WITH A GAS APPLIANCE. ONE SHALL BE LOCATED WITHIN EACH BEDROOM OR WITHIN 15' OR OF EACH BEDROOM DOORWAYS ON SEPARATE FLOORS REQUIRE SEPARATE DETECTORS.
- DISCHARGE COOKTOP RANGE VENT DUCTED TO OUTSIDE AIR WITH MIN 150 CFM INTERMITTENT RATED FAN.

## FOUNDATION NOTES

- FOOTINGS ARE TO BEAR ON UNDISTURBED LEVEL SOIL DEVOID OF ANY ORGANIC MATERIAL AND STEPPED AS REQUIRED TO MAINTAIN THE REQUIRED DEPTH BELOW THE FINAL GRADE.
- SOIL BEARING PRESSURE ASSUMED TO BE 1500 PSF.
- ANY FILL UNDER GRADE SUPPORTED SLABS TO BE A MINIMUM OF 4" GRANULAR MATERIAL COMPACTED TO 95%.
- CONCRETE TO DEVELOP A MIN. OF 2500 PSI AT 28 DAYS WITH A MIN. OF 6 BAGS OF CEMENT PER YARD AND A MAXIMUM SLUMP OF 4".
- CONCRETE SLABS TO HAVE CONTROL JOINTS AT 25' (MAXIMUM) INTERVALS EA WAY.
- CONCRETE SIDEWALKS TO HAVE 3/4" TOOLED JOINTS AT 5' OC. (MINIMUM).
- REINFORCING STEEL TO BE A-615 GRADE 40 WELDED WIRE MESH TO BE A-18.
- EXCAVATE THE SITE TO PROVIDE A MINIMUM OF 18" CLEARANCE UNDER ALL GIRDERS.
- COVER ENTIRE EXCAVATION WITH 1/2" MIL BLACK VISQUEEN AND EXTEND UP EDGEM WALLS TO PIT, MUDSILL, PROVIDE A MINIMUM OF 180 FT. OF VENTILATION AREA FOR EACH 150 SQ FT. OF CRACK/SPACE AREA. VENTS SHALL HAVE 1/4" OPENINGS IN CORROSION RESISTANT SCREEN.
- ALL WOOD IN CONTACT WITH CONCRETE TO BE PRESSURE TREATED OR PROTECTED WITH 304 PPM PROTECTANT.
- BEAM POCKETS IN CONCRETE TO HAVE 1/2" AIRSPACE AT SIDES AND ENDS WITH A MINIMUM BEARING OF 3".
- PROVIDE CRAWLSPACE DRAIN AS PER SEC. R409.1 OF ORSC.
- THE GRADE AWAY FROM FIND WALLS SHALL FALL 6" MIN. WITHIN FIRST 10'.
- SLOPE FOR PERMANENT FINLS AND CUT SLOPES SHALL NOT EXCEED 2 UNITS HORIZ. TO 1 UNIT VERT.
- BACKFILL SHALL NOT BE PLACED UNTIL WALL HAS SUFFICIENT STRENGTH AND HAS BEEN ANCHORED TO FLOOR ABOVE ON WALLS WITH MORE THAN 4 UNBALANCED BACKFILL.
- BUILDER SHALL BE RESPONSIBLE FOR SUPPORT OF ALL TEMPORARY EXCAVATIONS AND EXCAVATIONS.
- FOOTINGS SHALL BE FOUND ON FIRM, UNDISTURBED, NATIVE, FREE DRAINING SOILS. CONDITIONS FOUND TO BE OTHERWISE SHALL BE REPORTED TO OWNER.
- ALL GROUND OVER WHICH FOOTINGS AND SLABS-ON-GRADE ARE TO BE PLACED SHALL BE FREE OF EXPANSIVE OR COMPRESSIBLE DEBRIS AND ORGANIC MATERIAL.
- FOOTINGS AND SLABS-ON-GRADE CONCRETE SHALL NOT BE PLACED ON MUDDY OR FROZEN GROUND. SUB-GRADE FOR SLABS-ON-GRADE WHERE VAPOR BARRIER IS NOT REQUIRED SHALL BE DAMP AT THE OR CONCRETE PLACED.
- WOOD SOLE PLATES AT ALL EXTERIOR WALLS ON MONOLITHIC SLABS, AT ALL INTERIOR BRACE WALL PANELS ON MONOLITHIC SLABS AND AT ALL WOOD SILL PLATES SHALL BE ANCHORED TO THE FOUNDATION WITH MIN 1/2" X 1/2" BOLTS AT 6' OC. A 2029'X3'X3' WASHER SHALL BE TIGHTENED ON EACH ANCHOR BOLT. INSTALL MIN (2) BOLTS AT THE MIDDLE THIRD POINTS OF EACH PLATE.
- FOUNDATION WALLS BELOW GRADE SHALL BE DAMPROOFED FROM TOP OF THE FOOTING TO FINISHED GRADE WITH ANY OF THESE OPTIONS: 1) BITUMINOUS COATING; 2) 1/8" COATING OF SURFACE BONDING CEMENT COMPLYING WITH ASTM C 881; 3) 55 LBS ROLL ROOFING; 4) 16 MIL POLYETHYLENE; 5) 40 MIL FLEXIBLE POLYMER CEMENT.

## FRAMING NOTES

- ALL EXTERIOR WALL AND BEARING WALL OPENINGS TO HAVE 4X12 HEADERS UNLESS OTHERWISE INDICATED.
- JOISTS ARE TO BE ATTACHED TO FLUSH BEAMS ARE TO BE HUNG WITH 'SIMPSON' LUG TYPE OR EQUIV. 2x DOUBLE JOISTS THAT ARE ATTACHED TO FLUSH BEAMS ARE TO BE HUNG WITH 'SIMPSON' LUG TYPE OR EQUIV.
- PROVIDE DOUBLE JOISTS UNDER ALL PARALLEL PARTITIONS OVER.
- PROVIDE FIREBLOCKING, DRAFTSTOPS & FIRESTOPS AS PER THE ORSC SEC R602.8.
- LUMBER SPECIES:  
A. POSTS, BEAMS, HEADERS NO2 DOUG FIR  
B. SILLS, PLATES, BLOCKING NO3 DOUG FIR  
C. STUDS 2X4 GRADE DF  
D. POST AND BEAM DECKING UTILITY GRADE DF  
E. PLYWOOD SHEATHING 1/2" CDX PLY, 3/2" 16  
F. GULI-LAM BEAMS 16-2400 DRY ADH.  
SEE TABLE 602.3(1)
- NOTCHES IN SOLID LUMBER JOISTS, RAFTERS, AND BEAMS SHALL NOT EXCEED ONE-SIXTH OF THE DEPTH OF THE MEMBER. SHALL NOT BE LONGER THAN ONE-THIRD OF THE DEPTH OF THE MEMBER AND SHALL NOT BE LOCATED IN THE MIDDLE ONE-THIRD OF THE SPAN. NOTCHES AT THE ENDS OF THE MEMBER SHALL NOT EXCEED ONE-FOURTH THE DEPTH OF THE MEMBER. THE TENSION SIDE OF MEMBERS 4" (102mm) OR GREATER IN NOMINAL THICKNESS SHALL NOT BE NOTCHED EXCEPT AT ENDS OF THE MEMBERS. THE DIAMETER OF HOLES BORED OR CUT INTO MEMBERS SHALL NOT EXCEED ONE-THIRD THE DEPTH OF THE MEMBER. HOLES SHALL NOT BE CLOSER THAN 2" TO THE TOP OR BOTTOM OF THE MEMBER, OR TO ANY OTHER HOLE LOCATED IN THE MEMBER. WHERE THE MEMBER IS ALSO NOTCHED, THE HOLE SHALL NOT BE CLOSER THAN 2" (51mm) TO THE NOTCH.
- STUDS IN AN EXTERIOR WALL OR LOAD-BEARING PARTITIONS SHALL BE PERMITTED TO BE CUT OR NOTCHED TO A DEPTH NOT EXCEEDING 25% OF ITS WIDTH. STUDS IN NON-LOAD-BEARING PARTITIONS SHALL BE PERMITTED TO BE NOTCHED TO A DEPTH NOT TO EXCEED 50% OF A SINGLE STUD WIDTH. STUDS SHALL BE PERMITTED TO BE BORED OR DRILLED, PROVIDED THAT THE DIAMETER OF THE RESULTING HOLE IS NO GREATER THAN 40% OF THE STUD WIDTH. THE EDGE OF THE HOLE IS NO CLOSER THAN 5/8" (15.9mm) TO THE EDGE OF THE STUD, AND THE HOLE IS NOT LOCATED IN THE SAME SECTION AS A CUT OR NOTCH.
- INSTALL ALL HORIZONTAL MEMBERS WITH CROWN UP. ALL MEMBERS IN BEARING SHALL BE ACCURATELY CUT AND ALIGNED SO THAT ALL BEARINGS IS PROVIDED WITHOUT USE OF SHIMS, BEARING POSTS SHALL HAVE FULL BLOCKING OR SUPPORT UNDER.
- ALL JOISTS SHALL HAVE A MINIMUM OF 2" BEARING AT SUPPORTS. LAPPING JOISTS SHALL HAVE 6" LAPS CENTERED OVER INTERIOR SUPPORTS.
- LEDGERS AND STUD WALL FOUNDATION SILL PLATES SHALL BE BOLTED TO CONCRETE WITH ANCHOR BOLTS OF SIZE AND MINIMUM SPACING AS SHOWN ON DRAWINGS. AT LEAST TWO BOLTS SHALL BE PROVIDED FOR EACH PIECE WITH ONE BOLT WITHIN 12" OF EACH END.
- ALL PLYWOOD WALL SHEATHING SHALL BE APPLIED AS FOLLOWS: CENTER VERTICAL JOINTS OVER STUDS AND CENTER HORIZONTAL JOINT OVER 2" BLOCKING OR PLATE. NAIL TOP OF PANELS TO DOUBLE TOP PLATE AND NAIL BOTTOM OF PANELS TO ANCHORED SILL PLATE. APPLY GYPBUM BOARD SO THAT END JOINTS OF ADJACENT COURSE DO NOT OCCUR AT THE SAME STUD.

## ELECTRICAL REQUIREMENTS

- LIGHTING REQUIREMENTS:**  
AT LEAST ONE WALL SWITCH-CONTROLLED LIGHTING OUTLET SHALL BE INSTALLED IN EVERY HABITABLE ROOM AND IN BATHROOMS, HALLWAYS, STAIRWAYS, ATTACHED GARAGES, DETACHED GARAGES PROVIDED WITH ELECTRICAL POWER AND AT THE EXTERIOR SIDE OF GARAGE DOORS.
- STAIRWAY LIGHTING CONTROL:**  
ALL INTERIOR AND EXTERIOR STAIRWAYS SHALL BE PROVIDED WITH A MEANS OF ILLUMINATION TO THE STAIR, INCLUDING THE LANDINGS AND STAIRS, TO BE CONTROLLED BY A WALL SWITCH AT EACH FLOOR LEVEL. INTERIOR STAIRS SHALL BE PROVIDED WITH AN ARTIFICIAL LIGHT SOURCE LOCATED IN THE IMMEDIATE VICINITY OF EACH LANDING AT THE TOP AND BOTTOM OF THE STAIR. EXTERIOR STAIRS SHALL BE PROVIDED WITH AN ARTIFICIAL LIGHT SOURCE LOCATED IN THE IMMEDIATE VICINITY OF THE TOP LANDING OF THE STAIR. EXCEPTION: WHERE THE DIFFERENCE BETWEEN FLOOR LEVELS REQUIRES LESS THAN 6" STAIR RISES.
- FIXTURES IN CLOTHES CLOSETS:**  
SURFACE MOUNTED FLUORESCENT FIXTURES SHALL BE INSTALLED ON THE WALL ABOVE THE DOOR OR ON THE CEILING. PROVIDED THERE IS A MINIMUM CLEARANCE OF 6" BETWEEN THE FIXTURE AND THE NEAREST POINT OF A STORAGE SPACE.
- WET OR DAMP LOCATIONS:**  
FIXTURES INSTALLED IN WET OR DAMP LOCATIONS SHALL BE INSTALLED SO THAT WATER CANNOT ENTER OR ACCUMULATE IN WIRING COMPARTMENTS, LAMP HOLDERS OR OTHER ELECTRICAL PARTS. ALL FIXTURES INSTALLED IN WET LOCATIONS SHALL BE MARKED 'SUITABLE FOR WET LOCATIONS'. ALL FIXTURES INSTALLED IN DAMP LOCATIONS SHALL BE MARKED 'SUITABLE FOR WET LOCATIONS' OR 'SUITABLE FOR DAMP LOCATIONS'.
- LIGHT SWITCH ACCESS:**  
ALL SWITCHES SHALL BE LOCATED TO ALLOW OPERATION FROM A READILY ACCESSIBLE LOCATION.
- RECEPTACLE OUTLET REQUIREMENTS:**  
IN EVERY KITCHEN, FAMILY ROOM, DINING ROOM, LIVING ROOM, DEN, BEDROOM, OR SIMILAR ROOM OR AREA OF DWELLING UNITS, RECEPTACLE OUTLETS SHALL BE INSTALLED SO THAT NO POINT ALONG THE FLOOR LINE IN ANY WALL SPACE IS MORE THAN 6 FEET, MEASURED HORIZONTALLY FROM AN OUTLET IN THAT SPACE, INCLUDING ANY WALL SPACE THAT IS 2 FEET OR MORE IN WIDTH.
- KITCHENS:**  
RECEPTACLE OUTLETS, WITH GFI PROTECTION, SHALL BE INSTALLED EVERY 24" ON ALL COUNTER SPACES THAT MEASURE 12" OR WIDER.
- BATHROOMS:**  
AT LEAST ONE WALL RECEPTACLE OUTLET, WITH GFI PROTECTION, SHALL BE INSTALLED IN BATHROOMS ADJACENT TO EACH BATH LOCATION.
- OUTDOORS:**  
AT LEAST ONE RECEPTACLE OUTLET, WITH GFI PROTECTION, SHALL BE INSTALLED OUTDOORS AT THE FRONT AND BACK OF EACH DWELLING UNIT HAVING DIRECT ACCESS TO GRADE.
- HALLWAYS:**  
HALLWAYS OF 10 FEET OR MORE IN LENGTH SHALL HAVE AT LEAST ONE RECEPTACLE OUTLET.
- HVAC OUTLETS:**  
A CONDENSATE RECEPTACLE OUTLET SHALL BE INSTALLED FOR THE SERVICING OF HEATING, AIR-CONDITIONING AND REFRIGERATION EQUIPMENT LOCATED IN ATTICS AND CRAWL SPACES.
- WET LOCATIONS:**  
A RECEPTACLE INSTALLED IN A WET LOCATION SHALL BE IN A WEATHER PROOF ENCLOSURE, THE INTEGRITY OF WHICH IS NOT AFFECTED WHEN THE ATTACHMENT PLUG CAP IS INSERTED.

\*ADDITIONAL INFORMATION CAN BE FOUND IN THE OREGON RESIDENTIAL SPECIALTY CODE BOOK IN SECTIONS:

- E31-404 SWITCHES
- E31-406 RECEPTACLE OUTLETS
- E31-419 LIGHTING OUTLETS

### HIGH-EFFICIENCY INTERIOR LIGHTING SYSTEM:

- ALL PERMANENTLY INSTALLED LIGHTING FIXTURES SHALL CONTAIN HIGH EFFICACY LAMPS, SCREW-IN COMPACT FLUORESCENT AND LED LAMPS COMPLY WITH THIS REQUIREMENT. (EXCEPTION: TWO PERMANENTLY INSTALLED LIGHTING FIXTURES ARE NOT REQUIRED TO HAVE HIGH EFFICACY LAMPS)

### HIGH-EFFICIENCY EXTERIOR LIGHTING SYSTEM:

- ALL EXTERIOR LIGHTING FIXTURES AFFIXED TO THE EXTERIOR OF THE BUILDING SHALL CONTAIN HIGH EFFICACY LAMPS. (EXCEPTION: TWO PERMANENTLY INSTALLED LIGHTING FIXTURES ARE NOT TO HAVE HIGH EFFICACY LAMPS)

## TABLE N1101.1(1)

PERSCRIPTIVE ENVELOPE REQUIREMENTS

BUILDING COMPONENT	MIN. REQUIRED VALUE
WALL INSULATION- ABOVE GRADE	R-21 INTERMEDIATE c
WALL INSULATION- BELOW GRADE	R-15/R21
FLAT CEILING	R-49
VAULTED CEILING	R-30 RAFTER OR R-30/4 g1 SC1650R TRUSS
UNDERFLOORS	R-20
SLAB EDGE PERIMETER	R-15
HEATED SLAB INTERIOR	R-10
WINDOUS	U-0.30
SKYLIGHTS	U-0.50
EXTERIOR DOORS	U-0.20
EXTERIOR DRG W/ 23 SQ. FT. GLAZING	U-0.40
FORCED AIR DUCT INSULATION	R-8

- As allowed in Section N1101.4, thermal performance of a component may be adjusted provided that overall heat loss does not exceed the total resulting from conformance to the required U-values standards. Calculations to document equivalent heat loss shall be performed using the procedure and approved U-values contained in Table N1101.1(1).
- R-values used in this table are nominal, for the insulation only in standard wood framed construction and not for the entire assembly.
- Wall insulation requirements apply to all exterior wood framed, concrete or masonry walls that are above grade. This includes cripple walls and rim joist areas. Nominal compliance with R-21 insulation and Intermediate Framing (N1101.4.5) with insulated grade wood, concrete or masonry walls include all walls that are below grade and do not include those portions of such walls that extend more than 24 inches above grade. R-21 for insulation in framed cavity. R-15 continuous insulation.
- Insulation levels for ceilings that have limited attic/rafter depth such as dormers, bay windows or similar features totaling not more than 150 square feet in area may be reduced to not less than R-21 when reduced, the cavity shall be filled (except for required vent spaces) R-49 insulation installed to minimum 6-inches depth at top plate exterior of structure to achieve U-factor
- Vaulted ceiling surface area exceeding 50 percent of the total heated space floor area shall have a U-factor no greater than U-0.226 (equivalent to R-38 rafter or scissor truss with R-38 advanced framing)

n. A = Advanced frame construction. See section N1101.4.6

- Heated slab interior applies to concrete slab floors (both on and below grade) that incorporate a radiant heating system within the slab. Insulation shall be installed underneath the entire slab.

- Sliding glass doors shall comply with window performance requirements.

- Reduced area may not be used as a trade off criterion for thermal performance of any component.
- Skylights installed at 2 percent or less of total heated floor area shall be deemed to satisfy this requirement with vinyl, wood or thermally broken aluminum frames and double-pane glazing with low-emissivity coatings. Skylight U-factor is tested in the 20 degree overhead plane in accordance with NFRC standards.

- A maximum of 28 square feet of exterior door area per dwelling unit can have a U-factor of .54 or less.

- Glazing that is either double pane with low-e coating on one surface, or triple pane shall be deemed to comply with the U-0.30 requirement.

## TABLE N1101.1(2) ADDITIONAL MEASURES

ENVELOPE ENHANCEMENT MEASURES (SELECT ONE)	CONSERVATION MEASURE (SELECT ONE)
1. HIGH EFFICIENCY WALLS: EXTERIOR WALLS - U-0.045/R-21 CAVITY INSULATION + R-5 CONTINUOUS	1. UPGRADED FEATURES: EXTERIOR WALLS - U-0.051/R-23 INTERMEDIATE OR R-21 ADVANCED FRAMED FLOORS - U-0.016/R-38 AND WINDOUS - U-0.28 (AVERAGE UA)
2. UPGRADED FEATURES: EXTERIOR WALLS - U-0.051/R-23 INTERMEDIATE OR R-21 ADVANCED FLAT CEILING (e) - U-0.011/R60 AND FRAMED FLOORS - U-0.016/R-38	2. UPGRADED FEATURES: EXTERIOR WALLS - U-0.051/R-23 INTERMEDIATE OR R-21 ADVANCED FLAT CEILING (e) - U-0.011/R60 AND FRAMED FLOORS - U-0.016/R-38
3. SUPER INSULATED WINDOUS AND ATTIC OR FRAMED FLOORS: WINDOUS - U-0.22 (TRIPLE PANE LOW E), AND FLAT CEILING (e) - U-0.011/R60 OR FRAMED FLOORS - U-0.016/R-38	3. AIR SEALING HOPE AND DUCTS: MANDATORY AIR SEALING OF ALL WALL COVERINGS AT TOP PLATE AND AIR SEALING CHECKLIST (f) AND MECHANICAL WHOLE-BUILDING VENTILATION SYSTEM WITH RATES MEETING M193 OR ASHRAE 62.2, AND ALL DUCTS AND AIR HANDLERS CONTAINED WITHIN BUILDING ENVELOPE (d) OR ALL DUCTS SEALED WITH MASTIC (b)
4. HIGH EFFICIENCY THERMAL ENVELOPE (UA(g)): PROPOSED UA IS 15% LOWER THAN THE CODE UA	4. HIGH EFFICIENCY HVAC SYSTEM (a): GAS FIRED FURNACE OR BOILER AFUE 94%, OR AIR SOURCED HEAT PUMP HSPF 9.5/15.0 BEER COOLING, OR GROUND SOURCED HEAT PUMP COP 3.5 OR ENERGY STAR RATED
5. HIGH EFFICIENCY HVAC SYSTEM (a): GAS FIRED FURNACE OR BOILER AFUE 94%, OR AIR SOURCED HEAT PUMP HSPF 9.5/15.0 BEER COOLING, OR GROUND SOURCED HEAT PUMP COP 3.5 OR ENERGY STAR RATED	5. DUCTED HVAC SYSTEMS WITHIN CONDITIONED SPACE: ALL DUCTS AND AIR HANDLERS CONTAINED WITHIN BUILDING ENVELOPE (d) CANNOT BE COMBINED WITH MEASURE 5
6. DUCTLESS HEAT PUMP: DUCTLESS HEAT PUMP HSPF 10.0 IN PRIMARY ZONE OF DWELLING	6. DUCTLESS HEAT PUMP: DUCTLESS HEAT PUMP HSPF 10.0 IN PRIMARY ZONE OF DWELLING
7. HIGH EFFICIENCY WATER HEATER (c): NATURAL GAS / PROPANE WATER HEATER WITH UEF 0.85 OR ELECTRIC HEAT PUMP WATER HEATER TIER 1 NORTHERN CLIMATE SPECIFICATION PRODUCT	7. HIGH EFFICIENCY WATER HEATER (c): NATURAL GAS / PROPANE WATER HEATER WITH UEF 0.85 OR ELECTRIC HEAT PUMP WATER HEATER TIER 1 NORTHERN CLIMATE SPECIFICATION PRODUCT

FOR 91: 1 SQUARE FOOT = 0.093 M<sup>2</sup>; 1 WATT PER SQUARE FOOT = 10.8 W/M<sup>2</sup>

- Appliances located within the building thermal envelope shall have sealed combustion air installed. Combustion air shall be ducted directly from the outdoors.
- All duct joints and seams sealed with listed mastic; tape is only allowed at appliance or equipment connections (for service and replacement).
- Most sealing criteria of Performance Tested Comfort System program administered by the Bonneville Power Administration (BPA).
- Residential water heaters less than 55 gallon storage volume.
- A total of 5 percent of an HVAC system's ductwork shall be permitted to be located outside of the conditioned space. Ducts located outside the conditioned space shall have insulation installed as required in this code.
- The maximum vaulted ceiling surface area shall not be greater than 50 percent of the total heated floor space unless vaulted area has a U-factor no greater than U-0.226.
- Continuous air barrier. Additional requirement for sealing of all interior vertical wall covering to top plate framing. Sealing with foam gasket, caulk or other approved sealant listed for sealing wall covering material to structural material (example: gypsum board to wood stud framing).
- Table N1101.1(2) standard base case design. Code UA shall be at least 2 percent less than the Proposed Buildings U-values. Penetration less than 15 percent of the total vertical wall area may adjust to the Code UA to have 15 percent of the wall area as fenestration.

DISREGARD STRUCTURAL ITEMS DENOTED ON THE ARCHITECTURAL PLANS. REFER TO THE SEALED STRUCTURAL PLANS FOR ALL STRUCTURAL SPECIFICATIONS. THE STRUCTURAL PLANS WERE ENGINEERED WITH FRAMING SPECIFICATIONS PROVIDED BY THE BUILDER.

## SECTION N1107

LIGHTING

- ALL PERMANENTLY INSTALLED LIGHTING FIXTURES SHALL CONTAIN HIGH EFFICACY LAMPS, SCREW-IN COMPACT FLUORESCENT AND LED LAMPS COMPLY WITH THIS REQUIREMENT. (EXCEPTION: TWO PERMANENTLY INSTALLED LIGHTING FIXTURES ARE NOT REQUIRED TO HAVE HIGH EFFICACY LAMPS)
- ALL EXTERIOR LIGHTING FIXTURES AFFIXED TO THE EXTERIOR OF THE BUILDING SHALL CONTAIN HIGH EFFICACY LAMPS. (EXCEPTION: TWO PERMANENTLY INSTALLED LIGHTING FIXTURES ARE NOT REQUIRED TO HAVE HIGH EFFICACY LAMPS)

## FLOOR PLAN NOTES

- EACH BEDROOM TO HAVE A MINIMUM WINDOW OPENING OF 5.7 SQ FT WITH A MIN. WIDTH OF 20" AND A MIN. HEIGHT OF 21" AND A SILL LESS THAN 44" OFF THE FLOOR.
- ALL WINDOUS WITHIN 18" OF THE FLOOR AND WITHIN 34" OF ANY DOOR ARE TO HAVE TEMPERED GLAZING. SEE SECTION R308.4 IN ORSC FOR ADDITIONAL INFO.
- SKYLITES ARE TO BE GLAZED WITH TEMPERED GLASS ON OUTSIDE AND LAMINATED GLASS ON INSIDE (UNLESS FLEXIGLASS). GLASS TO HAVE MAXIMUM CLEAR SPAN OF 28". SKYLITE FRAME IS TO BE ATTACHED TO A 2" X CURB WITH MINIMUM OF 4" ABOVE ROOF PLANE.
- ALL TUB OR SHOWER ENCLOSURES ARE TO BE GLAZED WITH SAFETY GLAZING.
- ALL EXTERIOR WINDOUS ARE TO BE DOUBLE GLAZED AND ALL EXTERIOR DOORS ARE TO BE SOLID CORE WITH WEATHERSTRIPPING. PROVIDE 1/2" DEADBOLT LOCKS ON ALL EXTERIOR DOORS AND LOCKING DEVICES ON ALL DOORS OR WINDOUS WITHIN 10' (VERTICAL) OF GRADE. PROVIDE FREEP-HOLE # 54" (66" ABOVE FLOOR ON EXTERIOR DOORS).
- PROVIDE COMBUSTION AIR VENTS (W/ SCREEN AND BACK DAMPER) FOR FIREPLACES, WOOD STOVES AND ANY APPLIANCES WITH AN OPEN FLAME.
- Glazing that is either double pane with low-e coating on one surface, or triple pane shall be deemed to comply with the U-0.30 requirement.

**Suntec**  
DESIGN INC.  
16865 Boones Ferry Road, Suite 103, Lake Oswego, Oregon 97035  
Tel: (503) 624 0555-Fax: (503) 624 0155  
www.suntecbuildings.com

THESE PLANS HAVE BEEN LICENSED FOR THE CONSTRUCTION OF ONE BUILDING ONLY. UNAUTHORIZED USE OR COPYING OF THE PLANS, OR THE DESIGN THE DEFECT, INFRINGES RIGHTS UNDER THE COPYRIGHT ACT THAT INCLUDE PENALTIES OF UP TO \$100,000 PER WORK WILLFULLY INFRINGED. THESE PLANS HAVE BEEN PREPARED TO MEET CASO BUILDING CODES AND MAY REQUIRE ADAPTATION TO MEET SPECIFIC SITE CONDITIONS AND LOCAL BUILDING REGULATIONS. IT IS THE CONTRACTOR'S SOLE RESPONSIBILITY TO VERIFY ALL DIMENSIONS AND DETAILS PRIOR TO CONSTRUCTION FOR ERRORS AND OMISSIONS. PLEASE SEE YOUR LICENSE AGREEMENT FOR FURTHER INFORMATION.

SHEET: NOTES

DATE: 9/20/2019

N1



TABLE 602.3(1) FASTENER SCHEDULE FOR STRUCTURAL MEMBERS

ITEM	DESCRIPTION OF BUILDING ELEMENTS	NO. & TYPE OF FASTENER <sup>a,b,c</sup>	SPACING AND LOCATION
Roof			
1	Blocking between ceiling joists or rafters to top plate	4-8d box (2 1/2"x0.131") or 3-8d common (2 1/2"x0.131") or 3-10d box (3"x0.128") or 3-3"x0.131" nails	Toe nail
2	Ceiling joists to top plate	4-8d box (2 1/2"x0.131") or 3-8d common (2 1/2"x0.131") or 3-10d box (3"x0.128") or 3-3"x0.131" nails	Per joist, toe nail
3	Ceiling joists not attached to parallel rafter, laps over partitions (see Sections R602.3, R602.3.2, and Table R602.5.1(3))	4-10d box (2 1/2"x0.128") or 3-10d common (2 1/2"x0.162") or 4-3"x0.131" nails	Face nail
4	Ceiling joists attached to parallel rafter, heel joint (see Sections R602.3, R602.3.2, and Table R602.5.1(3))	Table R602.5.1(3)	Face nail
5	Collar tie to rafter, face nail or 1/4"x20 ga ridge strap to rafter	4-10d box (2 1/2"x0.131") or 3-10d common (2 1/2"x0.148") or 4-3"x0.131" nails	Face nail each rafter
6	Rafter or roof truss to plate	3-16d box (3 1/2"x0.135") or 3-10d common (3"x0.148") or 4-10d box (3"x0.128") or 4-3"x0.131" nails	2 toenails on one side and 1 toe nail on opposite side of each rafter or truss
7	Roof rafters to ridge, valley or hip rafters or roof rafter to minimum 2" ridge beam	4-16d box (3 1/2"x0.135") or 3-10d common (3"x0.148") or 4-10d box (3"x0.128") or 4-3"x0.131" nails	Toe nail
		3-16d box (3 1/2"x0.135") or 2-16d common (3 1/2"x0.162") or 3-3"x0.131" nails	End nail
Wall			
8	Stud to stud (not at braced wall panels)	16d common (3 1/2"x0.162") or 10d box (3 1/2"x0.128") or 3"x0.131" nails	24" o.c. face nail
9	Stud to stud and abutting studs at intersecting wall corners (at braced wall panels)	16d box (3 1/2"x0.135") or 3"x0.131" nails	12" o.c. face nail
		16d box (3 1/2"x0.162")	16" o.c. face nail
10	Built up header (2" to 2" header with 1/2" spacer)	16d common (3 1/2"x0.162") or 10d box (3 1/2"x0.135")	16" o.c. each edge face nail
11	Continuous header to stud	5-8d box (2 1/2"x0.131") or 4-8d common (2 1/2"x0.131") or 4-10d box (3"x0.128")	Toe nail
12	Top plate to top plate	16d common (3 1/2"x0.162") or 10d box (3 1/2"x0.128") or 3"x0.131" nails	12" o.c. face nail
13	Double top plate splice for SDC's A-D <sub>2</sub> with seismic braced wall line spacing less than 25'	8-16d common (3 1/2"x0.162") or 12-16d box (3 1/2"x0.135") or 12-10d box (3 1/2"x0.128") or 12-3"x0.131" nails	Face nail on each side of end joint (minimum 24" lap splice length)
	Double top plate splice for SDC's D <sub>1</sub> or D <sub>2</sub> and braced wall line spacing equal to or greater than 25'	12-16d box (3 1/2"x0.135")	Face nail on each side of end joint
14	Bottom plate to joist, rim joist, band joist, solid deck or blocking (not at braced wall panel)	16d common (3 1/2"x0.162") or 10d box (3 1/2"x0.135") or 3"x0.131" nails	16" o.c. face nail
15	Bottom plate to joist, rim joist, band joist, solid deck or blocking (at braced wall panel)	3-16d box (3 1/2"x0.135") or 2-16d common (3 1/2"x0.162") or 4-3"x0.131" nails	3 each 16" o.c. face nail 2 each 16" o.c. face nail 4 each 16" o.c. face nail
16	Top or bottom plate to stud	4-8d box (2 1/2"x0.131") or 3-8d common (2 1/2"x0.131") or 4-10d box (3"x0.128") or 4-3"x0.131" nails	Toe nail
		3-16d box (3 1/2"x0.135") or 2-16d common (3 1/2"x0.162") or 3-10d box (3"x0.128") or 3-3"x0.131" nails	End nail
17	Top plates, laps at corners and intersections	3-10d box (3"x0.128") or 2-16d common (3 1/2"x0.162") or 3-3"x0.131" nails	Face nail
18	1" brace to each stud and plate	3-8d box (2 1/2"x0.131") or 2-8d common (2 1/2"x0.131") or 2-10d box (3"x0.128") or 2 staples P <sub>4</sub>	Face nail
19	1"x6" sheathing to each bearing	3-8d box (2 1/2"x0.131") or 2-8d common (2 1/2"x0.131") or 2-10d box (3"x0.128") or 2 staples, 1" crown, 16 ga., P <sub>4</sub>	Face nail
20	1"x8" and wider sheathing to each bearing	3-8d box (2 1/2"x0.131") or 3-8d common (2 1/2"x0.131") or 3-10d box (3"x0.128") or 3 staples 1" crown, 16 ga., P <sub>4</sub>	Face nail

TABLE 602.3(1) FASTENER SCHEDULE FOR STRUCTURAL MEMBERS

ITEM	DESCRIPTION OF BUILDING ELEMENTS	NO. & TYPE OF FASTENER <sup>a,b,c</sup>	SPACING AND LOCATION	
Floor				
21	Joist to sill, top plate or girder	4-8d box (2 1/2"x0.131") or 3-8d common (2 1/2"x0.131") or 3-10d box (3"x0.128") or 3"x0.131" nails	Toe nail	
22	Rim joist, bandjoist or blocking to sill or top plate (roof applications also)	8d box (2 1/2"x0.131") or 8d common (2 1/2"x0.131") or 10d box (3"x0.128") or 3"x0.131" nails	4" o.c. toe nail	
23	1"x6" subfloor or less to each joist	3-8d box (2 1/2"x0.131") or 2-8d common (2 1/2"x0.131") or 3-10d box (3"x0.128") or 2 staples, 1" crown, 16 ga., P <sub>4</sub>	Face nail	
24	2" subfloor to joist or girder	3-16d box (3 1/2"x0.135") or 2-16d common (3 1/2"x0.162")	Blind and face nail	
25	2" planks (plank and beam - floor and roof)	3-16d box (3 1/2"x0.135") or 2-16d common (3 1/2"x0.162")	At each bearing, face nail	
26	Band or rim to joist	3-16d common (3 1/2"x0.162") or 4-10d box (3"x0.128") or 4-3"x0.131" nails or 4-3"x14 ga. staples, 7/16" crown	End nail	
27	Built-up girders and beams, 2 inch lumber layers	20d common (4"x0.192") or 10d box (3"x0.128") or 3-3"x0.131" nails	Nail each layer as follows: 32" o.c. at top and bottom, staggered	
		And: 2-20d common (4"x0.192") or 3-10d box (3"x0.128") or 3-3"x0.131" nails	24" o.c. face nail at top and bottom staggered on opposite sides	
28	Ledger strip supporting joists or rafters	4-16d box (3 1/2"x0.135") or 3-16d common (3 1/2"x0.162") or 4-10d box (3"x0.128") or 3-3"x0.131" nails	At each joist or rafter, face nail	
29	Bridging to joist	2-10d (3"x0.128")	Each end, toe nail	
SPACING OF FASTENERS				
ITEM	DESCRIPTION OF BUILDING ELEMENTS	NO. & TYPE OF FASTENER <sup>a,b,c</sup>	Edges (inches) <sup>d</sup>	Intermediate supports (inches) <sup>e,f</sup>
Wood structural panels, subfloor, roof and interior wall sheathing to framing and particleboard wall sheathing to framing. (see table R602.3(3) for wood structural panel exterior wall sheathing to wall framing)				
30	3/8" - 1/2"	6d common (2"x0.113") nail (subfloor, wall) or 8d common (2 1/2"x0.131") nail (roof)	6	12
31	1/2" - 1"	8d common (2 1/2"x0.131") nail (roof)	6	12
32	1 1/8" - 1 1/4"	10d common (3"x0.148") nail or 8d (2 1/2"x0.131") deformed nail	6	12
Other wall sheathing <sup>g</sup>				
33	1/2" structural cellulose fiberboard sheathing	1 1/2" galvanized roofing nail, 7/16" head diameter, or 1" crown staple 16 ga., 1 1/4" long	3	6
34	25/32" structural cellulose fiberboard sheathing	1 3/4" galvanized roofing nail, 7/16" head diameter, or 1" crown staple 16 ga., 1 1/4" long	3	6
35	1/2" gypsum sheathing	1 1/2" galvanized roofing nail; staple galvanized, 1 1/4" screws, Type W or S	7	7
36	5/8" gypsum sheathing	1 3/4" galvanized roofing nail; staple galvanized, 1 5/8" screws, Type W or S	7	7
Wood structural panels, combination subfloor underlayment to framing				
37	3/4" and less	6d deformed (2"x0.120") nail or 8d common (2 1/2"x0.131") nail	6	12
38	7/8" - 1"	8d common (2 1/2"x0.131") nail or 8d deformed (2 1/2"x0.131") nail	6	12
39	1 1/8" - 1 1/4"	10d common (3"x0.148") nail or 8d deformed (2 1/2"x0.131") nail	6	12

FOR S1: 1 INCH = 25.4 MM, 1 FOOT = 304.8 MM, 1 MPH = 0.447 M/S; 1 KSI = 6.895 MPa

a. ALL NAILS ARE SMOOTH-COMMON, BOX OR DEFORMED SHANKS EXCEPT WHERE OTHERWISE STATED. NAILS USED FOR FRAMING AND SHEATHING CONNECTIONS SHALL HAVE MINIMUM AVERAGE BENDING YIELD STRENGTHS AS SHOWN: 80 ksi (551 MPa) FOR SHANK DIAMETER OF 0.131 INCH (20d COMMON NAIL), 90 KSI FOR SHANK DIAMETERS LARGER THAN 0.142 INCH BUT NOT LARGER THAN 0.171 INCH, AND 100 KSI FOR SHANK DIAMETERS OF 0.142 INCH OR LESS.

b. STAPLES ARE 16 GAUGE WIRE AND HAVE A MINIMUM 7/16-INCH OD, CROWN WIDTH.

c. NAILS SHALL BE SPACED AT NOT MORE THAN 6 INCHES O.C. AT ALL SUPPORTS WHERE SPANS ARE 48 INCHES OR GREATER.

d. 4-FOOT-BY-8-FOOT OR 4-FOOT-BY-9-FOOT PANELS SHALL BE APPLIED VERTICALLY.

e. SPACING OF FASTENERS NOT INCLUDED IN THIS TABLE SHALL BE BASED ON TABLE 602.3(2).

f. WHERE THE ULTIMATE DESIGN WIND SPEED IS 150 MPH OR LESS, NAILS FOR ATTACHING WOOD STRUCTURAL PANEL ROOF SHEATHING TO GABLE END WALL FRAMING SHALL BE SPACED 6" ON CENTER, WHERE THE ULTIMATE DESIGN WIND SPEED IS GREATER THAN 150 MPH, NAILS FOR ATTACHING PANEL ROOF SHEATHING TO INTERMEDIATE SUPPORTS SHALL BE SPACED 6" ON CENTER FOR MINIMUM 48 INCH DISTANCES FROM RIDGES, EAVES AND GABLE END WALLS; AND 4 INCHES ON CENTER TO GABLE END WALL FRAMING.

g. GYPSUM SHEATHING SHALL CONFORM TO ASTM C1396 AND SHALL BE INSTALLED IN ACCORDANCE WITH GA 253. FIBERBOARD SHEATHING SHALL CONFORM TO ASTM C208.

h. SPACING OF FASTENERS ON FLOOR SHEATHING PANEL EDGES APPLIES TO PANEL EDGES SUPPORTED BY FRAMING MEMBERS AND REQUIRED BLOCKING AND AT ALL FLOOR PERIMETERS ONLY. SPACING OF FASTENERS ON ROOF SHEATHING PANEL EDGES APPLIES TO PANEL EDGES SUPPORTED BY FRAMING MEMBERS AND REQUIRED BLOCKING. BLOCKING TO ROOF OR FLOOR SHEATHING PANEL EDGES PERPENDICULAR TO THE FRAMING MEMBERS NEED NOT BE PROVIDED EXCEPT AS REQUIRED BY OTHER PROVISIONS OF THIS CODE. FLOOR PERIMETER SHALL BE SUPPORTED BY FRAMING MEMBERS OR SOLID BLOCKING.

i. WHERE A RAFTER FASTENED TO AN ADJACENT PARALLEL CEILING JOIST IN ACCORDANCE WITH THIS SCHEDULE, PROVIDE TWO TOE NAILS ON ONE SIDE OF THE RAFTER AND TOE NAILS FROM THE CEILING JOIST TO TOP PLATE IN ACCORDANCE WITH THIS SCHEDULE. THE TOE NAIL ON THE OPPOSITE SIDE OF THE RAFTER SHALL NOT BE REQUIRED.

j. INTERIOR NON-BRACED WALL LINES MAY BE NAILED WITH A MINIMUM 4-10d NAILS.

INSULATION SPECIFICATIONS

- ALL EXPOSED INSULATION IS TO HAVE A FLAME SPREAD RATING OF LESS THAN 25 & A SMOKE DENSITY RATING OF LESS THAN 450.
- PERIMETER CONC. WALLS TO BE PROTECTED W/ RIGID FIBERBOARD INSULATION FROM TOP OF CONC WALL TO NOT LESS THAN 2" BELOW GRADE.
- SLAB EDGE INSULATION IS TO BE R-15.
- HEATING DUCTS TO BE INSULATED W/ R-8.
- WINDOWS SHALL MEET REQUIRED U FACTORS FOR THE CONTRACTOR'S CHOSEN PATH OF COMPLIANCE SEE TABLE N102.1(1).
- ONE EXTERIOR DOOR MAY BE INSULATED TO A U-FACTOR OF 0.20. ALL OTHER EXTERIOR DOORS MAY NOT EXCEED 0.54.

TRUSS NOTE

SUBMIT TRUSS DESIGN FOR ENGINEERING PRIOR TO FABRICATION & VERIFY LOCATION OF GIRDER TRUSSES W/ TRUSS COMPANY PRIOR TO FORMING FOUNDATION WALLS AS TO PROVIDE FOR ADDITIONAL LOADING FROM VARYING TRUSS DESIGN. VERIFY ALL TRUSS SPANS & CONFIGURATIONS ON JOB SITE PRIOR TO FABRICATION.

DISREGARD STRUCTURAL ITEMS DENOTED ON THE ARCHITECTURAL PLANS. REFER TO THE SEALED STRUCTURAL PLANS FOR ALL STRUCTURAL SPECIFICATIONS. THE STRUCTURAL PLANS WERE ENGINEERED WITH FRAMING SPECIFICATIONS PROVIDED BY THE BUILDER.

**Sumtel**  
DESIGN INC.  
16865 Boones Ferry Road, Suite 103, Lake Oswego, Oregon 97035  
Tel: (503) 624 0555-Fax: (503) 624 0155  
www.sumtelinc.com

THESE PLANS HAVE BEEN LICENSED FOR THE CONSTRUCTION OF ONE BUILDING ONLY. UNAUTHORIZED USE OR COPIING OF THE PLANS, OR THE DESIGN THEREOF, INFRINGES RIGHTS UNDER THE COPYRIGHT ACT THAT INCLUDE PENALTIES OF UP TO \$100,000 PER WORK WILLFULLY INFRINGED. THESE PLANS HAVE BEEN PREPARED TO MEET OREGON BUILDING CODES AND MAY REQUIRE ADAPTATION TO MEET SPECIFIC SITE CONDITIONS AND LOCAL BUILDING REGULATIONS. IT IS THE CONTRACTOR'S SOLE RESPONSIBILITY TO VERIFY ALL DIMENSIONS AND DETAILS PRIOR TO CONSTRUCTION FOR ERRORS AND OMISSIONS. PLEASE SEE YOUR LICENSE AGREEMENT FOR FURTHER INFORMATION.

SHEET: NOTES  
DATE: 02/08









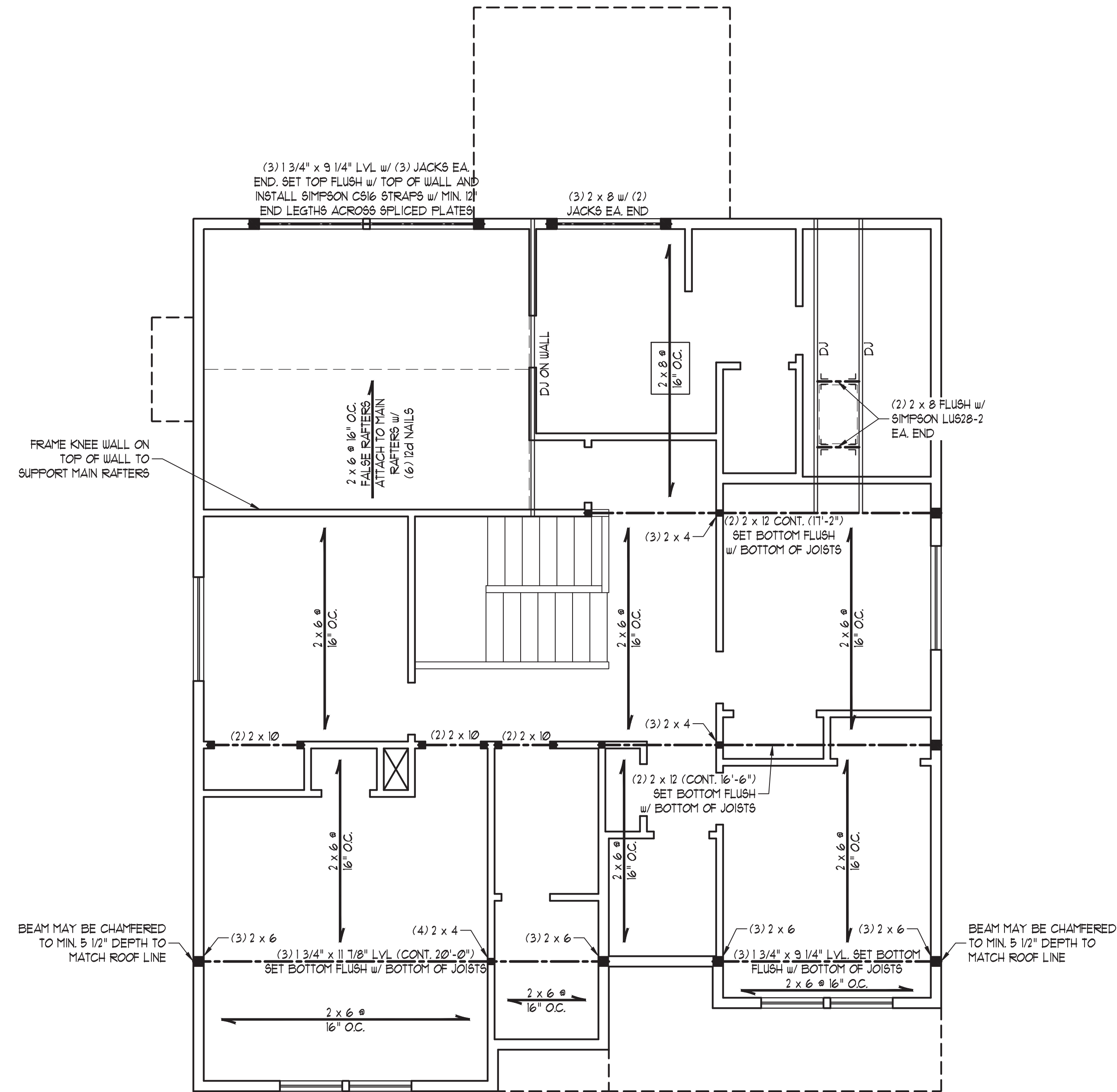

**BRACED WALL DESIGN NOTES:**

1. BRACED WALL DESIGN PER SECTION R602.10 OF THE NRC 2018 EDITION.
2. CS-WSP REFERS TO "CONTINUOUS SHEATHING - WOOD STRUCTURAL PANELS" CONTRACTOR IS TO INSTALL 1/2" OSB ON ALL EXTERIOR WALLS ATTACHED W/ 8d NAILS SPACED 6" O.C. ALONG PANEL EDGES AND 12" O.C. IN THE FIELD.
3. GB REFERS TO "GYPSUM BOARD" CONTRACTOR IS TO INSTALL 1/2" (MIN) GYPSUM WALL BOARD WHERE NOTED ON THE PLANS. FASTEN GB WITH 1 1/4" SCREWS OR 1 5/8" NAILS SPACED 1" O.C. ALONG PANEL EDGES AND IN THE FIELD INCLUDING TOP AND BOTTOM FLATES.
4. BRACED WALL DESIGN APPLIED IN WIND ZONES UP TO 130 MPH. FOR HIGH WIND ZONES BRACE WALLS ARE TO BE CONSTRUCTED IN ACCORDANCE WITH CHAPTER 45 OF THE NRC 2018 EDITION.
5. SEE NOTES AND DETAIL SHEETS FOR ADDITIONAL BRACED WALL INFORMATION.

**NOTE:**

1. PER SECTION R602.10.32 OF THE 2018 NRC, THE AMOUNT OF BRACING ON THE SECOND FLOOR EXCEEDS THE AMOUNT REQUIRED FOR THE FIRST FLOOR AND NO BRACED WALL ANALYSIS IS REQUIRED.
2. SHEATH ALL EXTERIOR WALLS WITH 1/2" OSB SHEATHING ATTACHED WITH 8d NAILS AT 6" O.C. ALONG PANEL EDGES AND 12" O.C. IN THE FIELD.

**STRUCTURAL NOTES:**

1. ALL FRAMING LUMBER TO BE #2 SFF (UNO).
2. ALL LOAD BEARING HEADERS TO BE (3) 2 x 6 (UNO).
3. WINDOW AND DOOR HEADERS TO BE SUPPORTED W/ (1) JACK STUD AND (1) KING STUD EA. END (UNO). SEE TABLE R602.15 FOR ADDITIONAL KING STUD REQUIREMENTS.
4. SQUARES DENOTE POINT LOADS WHICH REQUIRE SOLID BLOCKING TO GIRDER OR FOUNDATION. SQUARES TO BE (2) STUDS (UNO.)
5. REFER TO NOTES AND DETAIL SHEETS FOR ADDITIONAL STRUCTURAL INFORMATION.

TABLE R602.15  
MINIMUM NUMBER OF FULL HEIGHT STUDS AT EACH END OF HEADERS IN EXTERIOR WALLS

HEADER SPAN (FEET)	MAXIMUM STUD SPACING (INCHES) (PER TABLE R602.3.5)	
	16	24
UP TO 3'	1	1
4'	2	1
8'	3	2
12'	5	3
16'	6	4

**LEGEND**

CONT	CONTINUOUS
XJ	EXTRA JOIST
DJ	DOUBLE JOIST
TJ	TRIPLE JOIST
EA	EACH
( )	NUMBER OF STUDS
D&P	DOUBLE STUD POCKET
T&P	TRIPLE STUD POCKET
OC	ON CENTER
SFF	SPRUCE PINE FIR
SYP	SOUTHERN YELLOW PINE
TRTD	PRESSURE TREATED
TYP	TYPICAL
UNO	UNLESS NOTED OTHERWISE

**J.S. THOMPSON  
ENGINEERING, INC**  
606 WADE AVE., SUITE 104 RALEIGH, NC 27605  
PHONE: (919) 789-9919 FAX: (919) 789-9921  
N.C. LICENSE NO.: C-1733

AVERY J - 52214J  
76 CHARTER STREET  
CAMERON, NORTH CAROLINA  
SOLE SOURCE SOLUTION

DATE: JULY 29, 2021  
SCALE: 1/4" = 1'-0"  
DRAWN BY: SUNTEL DESIGN, INC  
ENGINEERED BY: ZHH

SHEET: 3 OF 4  
S-3  
ATTIC FLOOR  
FRAMING PLAN



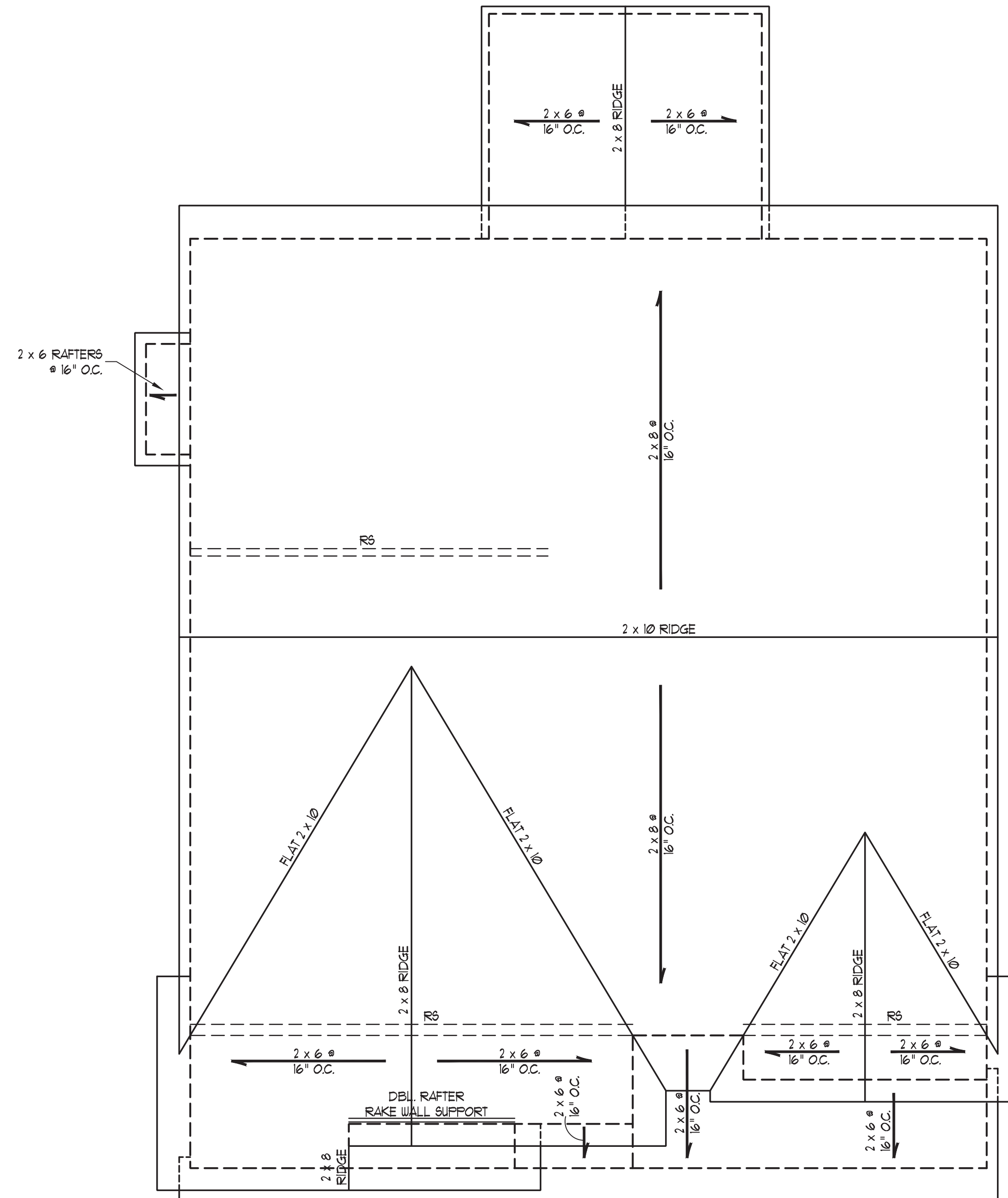

- STRUCTURAL NOTES:**
1. ALL FRAMING LUMBER TO BE #2 SFF (UNO).
  2. STICK FRAME OVER-FRAMED ROOF SECTIONS W/ 2 x 8 RIDGES, 2 x 6 RAFTERS @ 16" O.C. AND FLAT 2 x 10 VALLEYS.
  3. FASTEN FLAT VALLEYS TO RAFTERS WITH SIMPSON H25A HURRICANE TIES @ 32" O.C. MAX. PASS HURRICANE TIES THROUGH NOTCH IN ROOF SHEATHING. EACH RAFTER IS TO BE FASTENED TO THE FLAT VALLEY WITH A MIN. OF (6) 12d TOE NAILS.
  4. REFER TO SECTION R802.11 OF THE 2018 NRC FOR REQUIRED UPLIFT RESISTANCE AT RAFTERS.
  5. REFER TO NOTES AND DETAIL SHEETS FOR ADDITIONAL STRUCTURAL INFORMATION.

NOTE: REFER TO ARCHITECTURAL DRAWINGS FOR ROOF PITCHES, PLATE HEIGHTS, DIMENSIONS, OVERHANG WIDTHS, AND ATTIC VENT CALCS.

**LEGEND**

XR	EXTRA RAFTER
DR	DOUBLE RAFTER
TR	TRIPLE RAFTER
RS	RAFTER SUPPORT
CONT	CONTINUOUS
EA	EACH
OC	ON CENTER
SFF	SPRUCE PINE FIR
SYP	SOUTHERN YELLOW PINE
TYP	TYPICAL
UNO	UNLESS NOTED OTHERWISE

**J.S. THOMPSON ENGINEERING, INC**  
 606 WADE AVE., SUITE 104 RALEIGH, NC 27605  
 PHONE: (919) 789-9919 FAX: (919) 789-9921  
 N.C. LICENSE NO.: C-1733

EVERY J - 52214J  
 76 CHARTER STREET  
 CAMERON, NORTH CAROLINA  
 SOLE SOURCE SOLUTION

DATE: JULY 29, 2021  
 SCALE: 1/4" = 1'-0"  
 DRAWN BY: SUNTEL DESIGN, INC  
 ENGINEERED BY: ZHH



SHEET 4 OF 4  
 S-4  
 ROOF FRAMING PLAN

7/30/2021



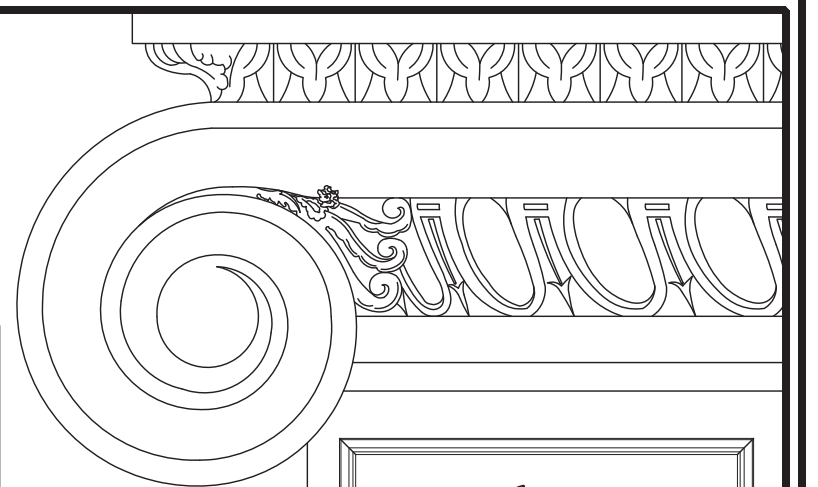

**GENERAL WALL BRACING NOTES:**

1. WALL BRACING DESIGNED IN ACCORDANCE WITH CHAPTER 6 OF THE 2018 NC RESIDENTIAL BUILDING CODE (NRC). TABLES AND FIGURES REFERENCED ARE FROM THE 2018 NRC.
2. SEE THIS SHEET FOR GENERAL DETAILS. REFER TO THE 2018 NRC FOR ADDITIONAL INFORMATION AS NEEDED.
3. BRACED EXTERIOR WALLS SUPPORTING ROOF TRUSSES AND RAFTERS, INCLUDING STORIES BELOW THE TOP FLOOR, HAVE BEEN DESIGNED PER R602.3.5 (3). WALL SHEATHING AND FASTENERS HAVE BEEN DESIGNED TO RESIST COMBINED UPLIFT AND SHEAR FORCES IN ACCORDANCE WITH ACCEPTED ENGINEERING PRACTICE.
4. SEE STRUCTURAL SHEETS FOR BRACED WALL LOCATIONS, DIMENSIONS, HOLD DOWN TYPE AND LOCATIONS, BRACED WALL LINE KEY WITH WALL DESIGN SUMMARY OF REQUIRED/PROVIDED TOTALS FOR EACH WALL LINE AND ANY SPECIAL NOTES OR REQUIREMENTS.
5. ALL EXTERIOR WALLS ARE TO BE SHEATHED WITH CS-WSP IN ACCORDANCE WITH SECTION R602.10.3 UNLESS NOTED OTHERWISE.
6. ALL EXTERIOR AND INTERIOR WALLS TO HAVE 1/2" GYPSUM INSTALLED. WHEN NOT USING METHOD "GB", GYPSUM TO BE FASTENED PER TABLE R102.3.5. METHOD GB TO BE FASTENED PER TABLE R602.10.1.
7. CS-WSP REFERS TO THE "CONTINUOUS SHEATHING - WOOD STRUCTURAL PANELS" WALL BRACING METHOD. 1/16" OSB SHEATHING IS TO BE INSTALLED ON ALL EXTERIOR WALLS ATTACHED w/ 6d COMMON NAILS OR 8d (2 1/2" LONG x Ø13" DIAMETER) NAILS SPACED 6" O.C. ALONG PANEL EDGES AND 12" O.C. IN THE FIELD (UNO).
8. GB REFERS TO THE "GYPSUM BOARD" WALL BRACING METHOD. 1/2" (MIN) GYPSUM WALL BOARD IS TO BE INSTALLED ON BOTH SIDES OF THE BRACED WALL FASTENED WITH 1 1/4" SCREWS OR 1 5/8" NAILS SPACED 1" O.C. ALONG PANEL EDGES INCLUDING TOP AND BOTTOM PLATES AND INTERMEDIATE SUPPORTS (UNO). VERIFY ALL FASTENER OPTIONS FOR 1/2" AND 5/8" GYPSUM PRIOR TO CONSTRUCTION. FOR INTERIOR FASTENER OPTIONS SEE TABLE R102.3.5. FOR EXTERIOR FASTENER OPTIONS SEE TABLE R602.3(1). EXTERIOR GB TO BE INSTALLED VERTICALLY.
9. REQUIRED BRACED WALL LENGTH FOR EACH SIDE OF THE CIRCUMSCRIBED RECTANGLE ARE INTERPOLATED PER TABLE R602.10.3. METHOD CS-WSP CONTRIBUTES ITS ACTUAL LENGTH, METHOD GB CONTRIBUTES 5 ITS ACTUAL LENGTH, AND METHOD PF CONTRIBUTES 15 TIMES ITS ACTUAL LENGTH.

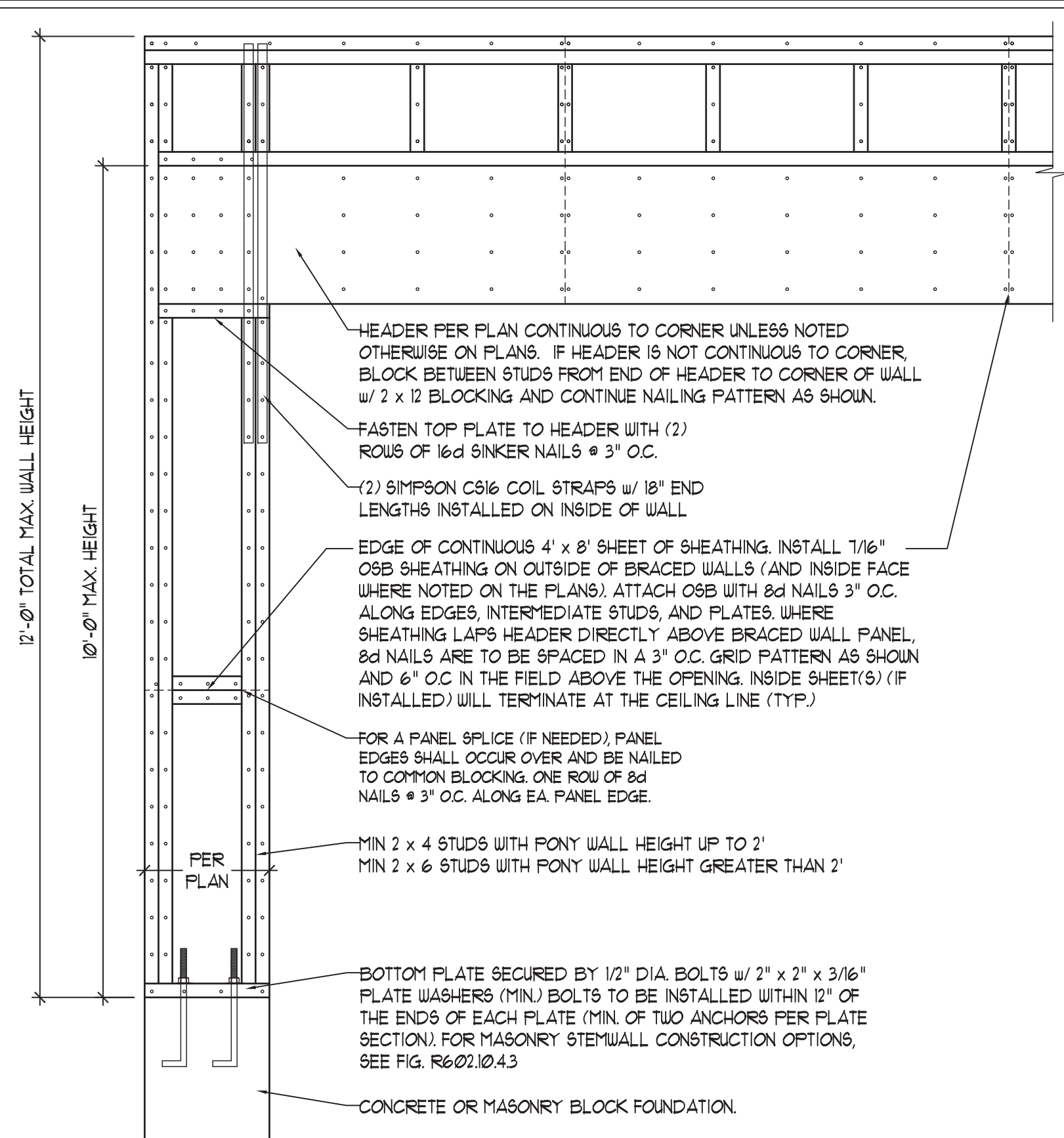

OVER CONCRETE OR MASONRY BLOCK FOUNDATION

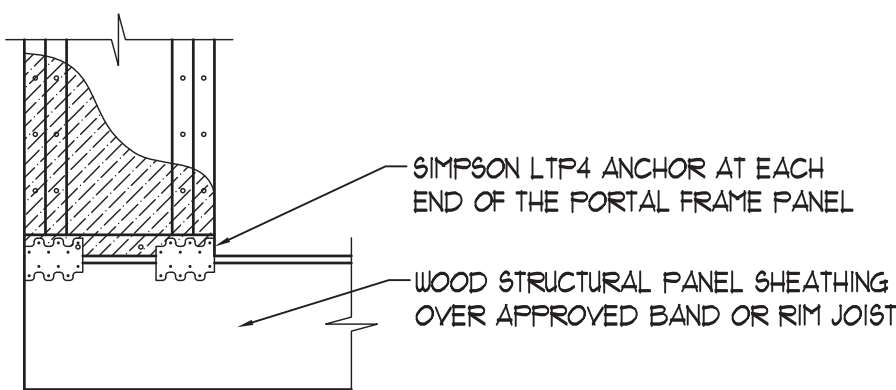

OVER RAISED WOOD FLOOR - FRAMING ANCHOR OPTION  
 \* APPLICABLE w/ GREATER THAN 12" KNEE WALL HEIGHTS IN CRAWL SPACE AND ABOVE FRAMED BASEMENT WALLS \*

**METHOD PF-PORTAL FRAME DETAIL ①**

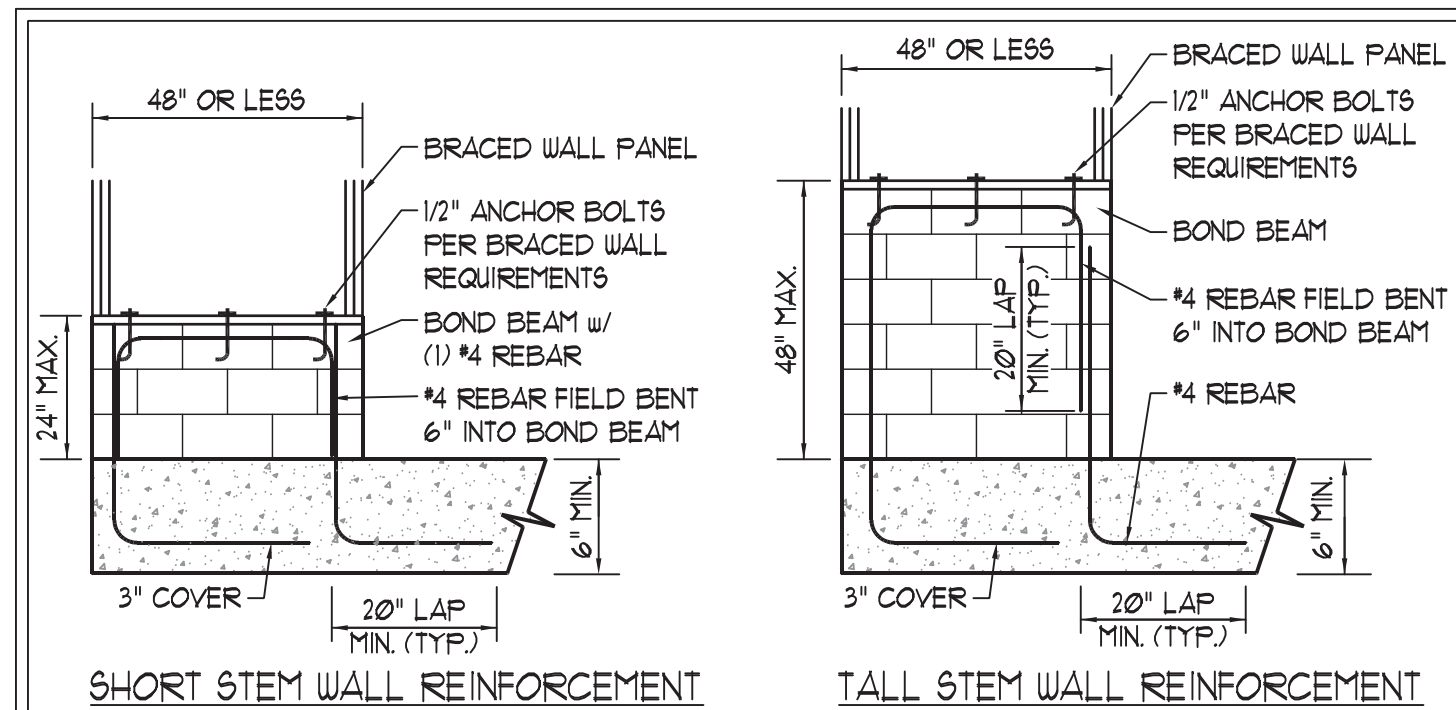

SHORT STEM WALL REINFORCEMENT TALL STEM WALL REINFORCEMENT

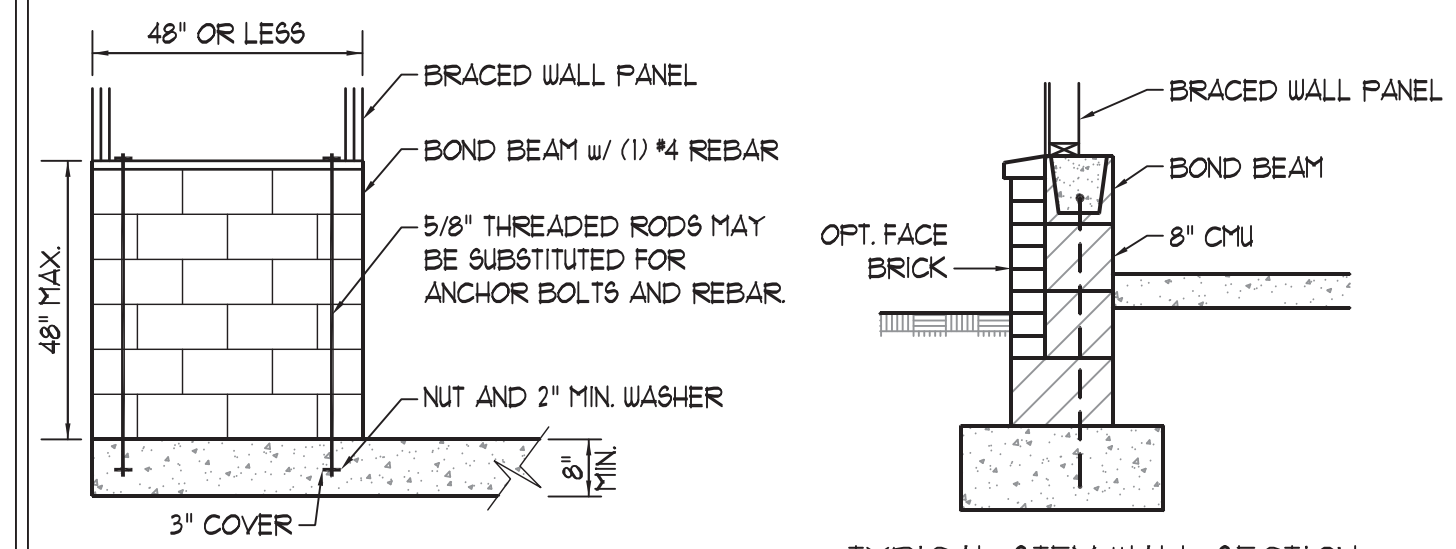

TYPICAL STEM WALL SECTION

RODS MAY BE INSTALLED USING AN ADHESIVE ANCHORING SYSTEM WITH A MINIMUM TENSILE CAPACITY OF 3750 LBS AND INSTALLED IN ACCORDANCE WITH MANUFACTURER'S SPECS.  
**OPTIONAL STEM WALL REINFORCEMENT**  
 NOTE: GROUT BOND BEAMS AND ALL CELLS WHICH CONTAIN REBAR, THREADED RODS AND ANCHOR BOLTS  
**MASONRY STEM WALLS SUPPORTING BRACED WALL PANELS ②**  
 PER FIGURE R602.10.4.3

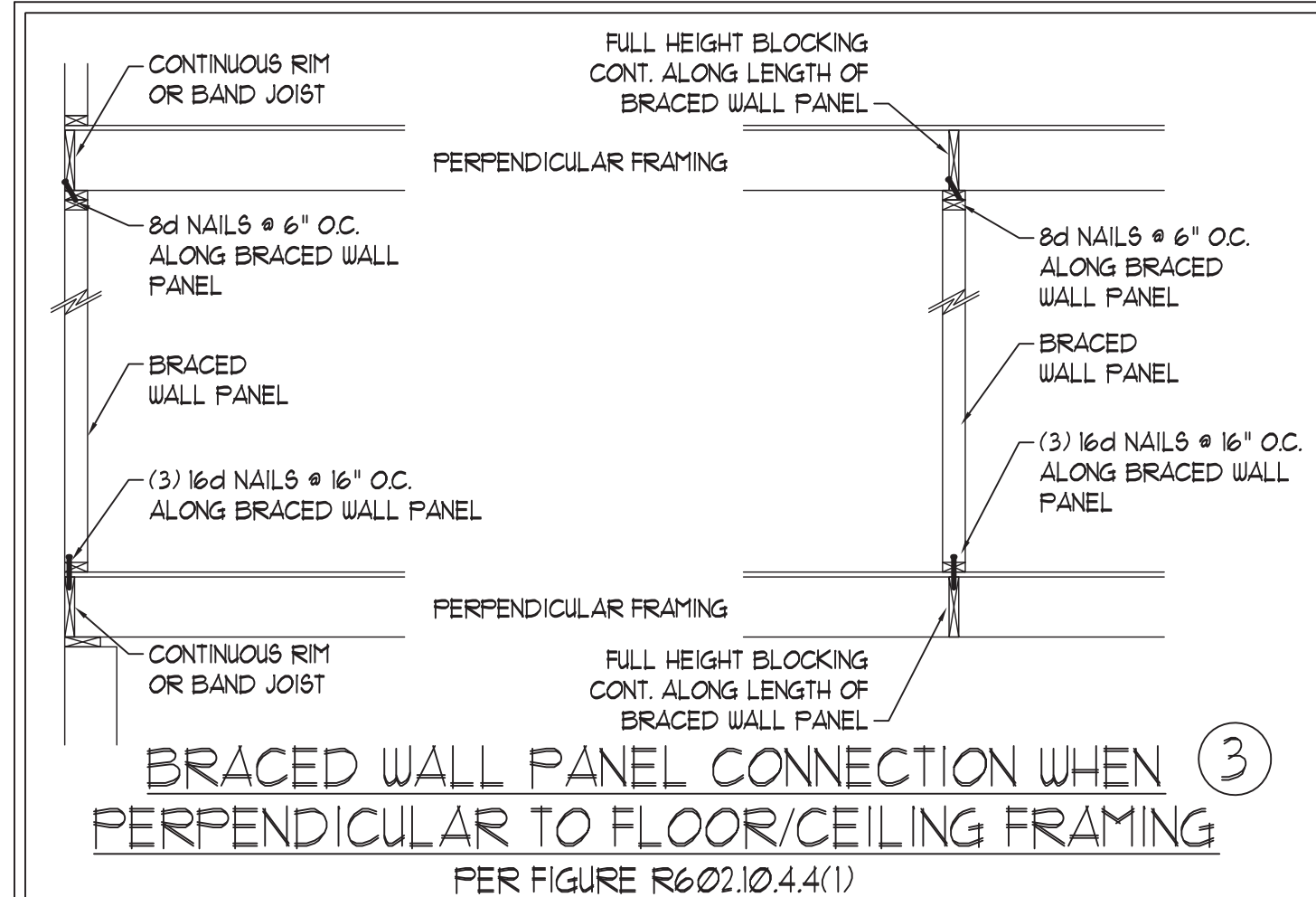

**BRACED WALL PANEL CONNECTION WHEN PERPENDICULAR TO FLOOR/CEILING FRAMING ③**  
 PER FIGURE R602.10.4.4(1)

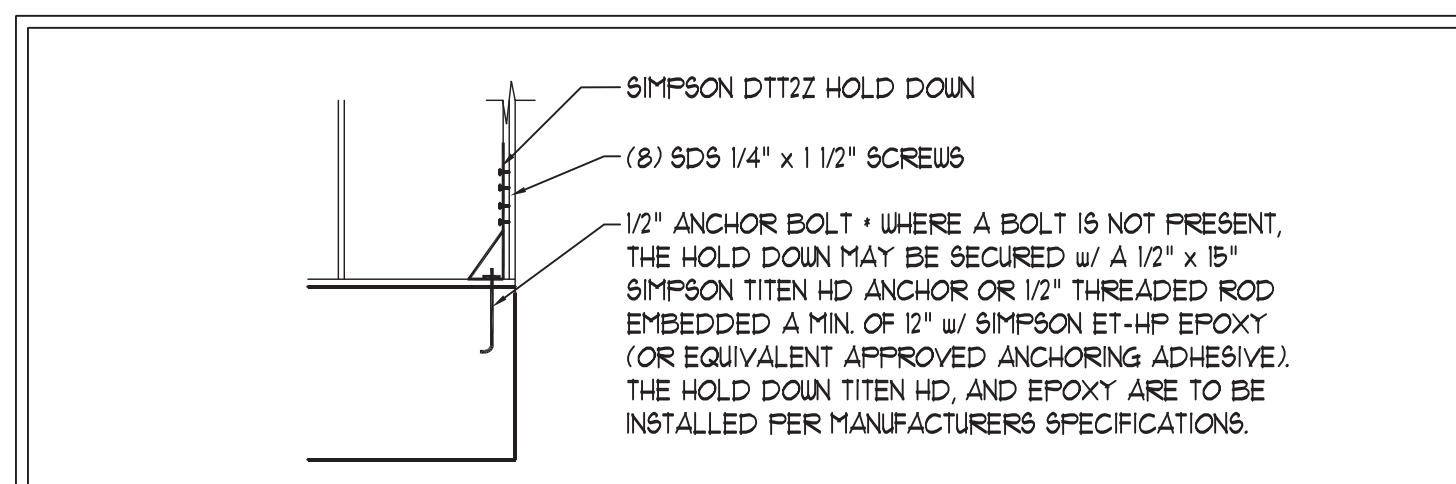

**HOLD DOWN DETAIL FOR MASONRY FOUNDATION OR MONOLITHIC SLAB ④**  
 \* APPLICABLE ONLY WHERE SPECIFIED ON PLAN \*

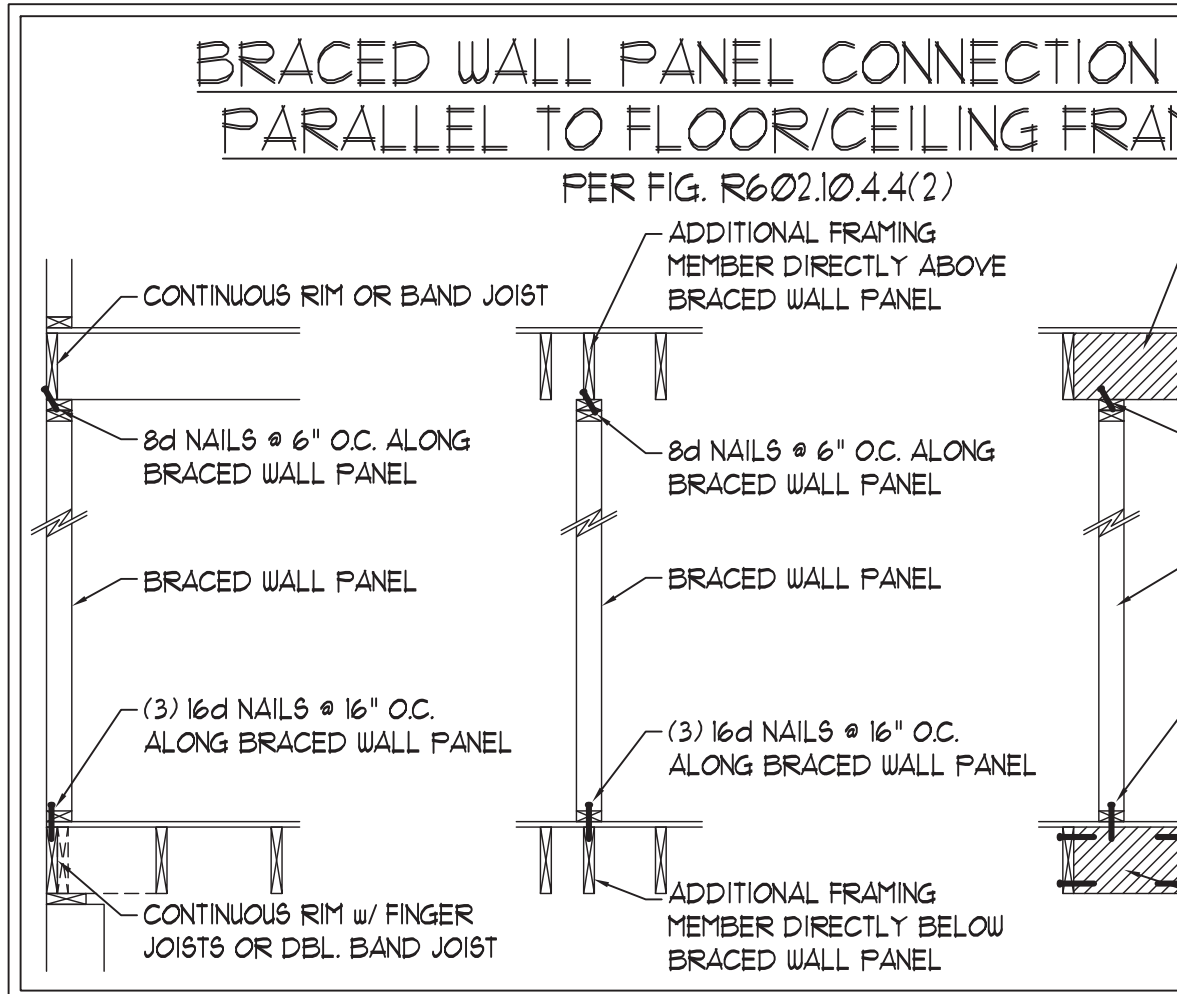
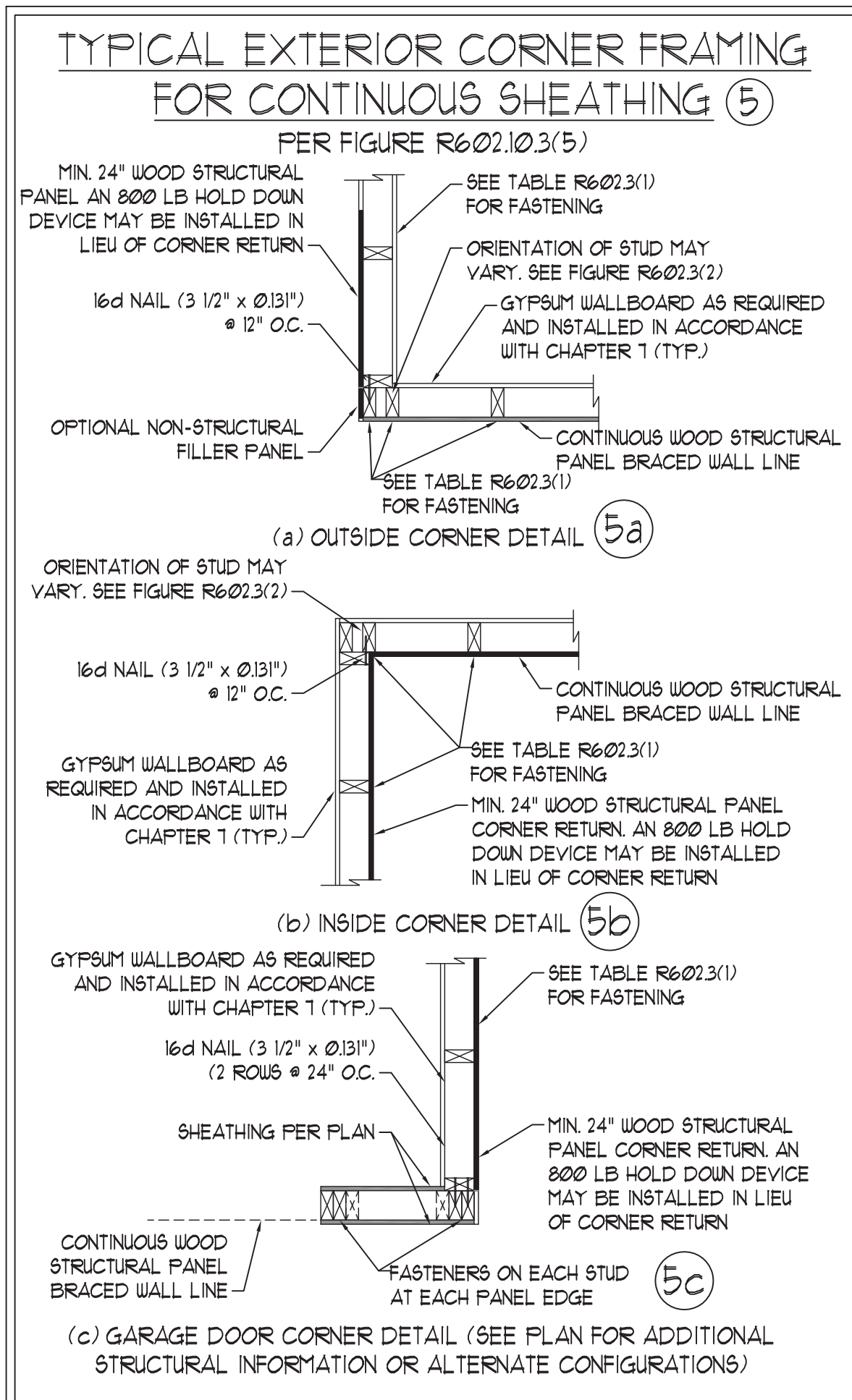

**BRACED WALL PANEL CONNECTION WHEN PARALLEL TO FLOOR/CEILING FRAMING ⑥**  
 PER FIG. R602.10.4.4(2)

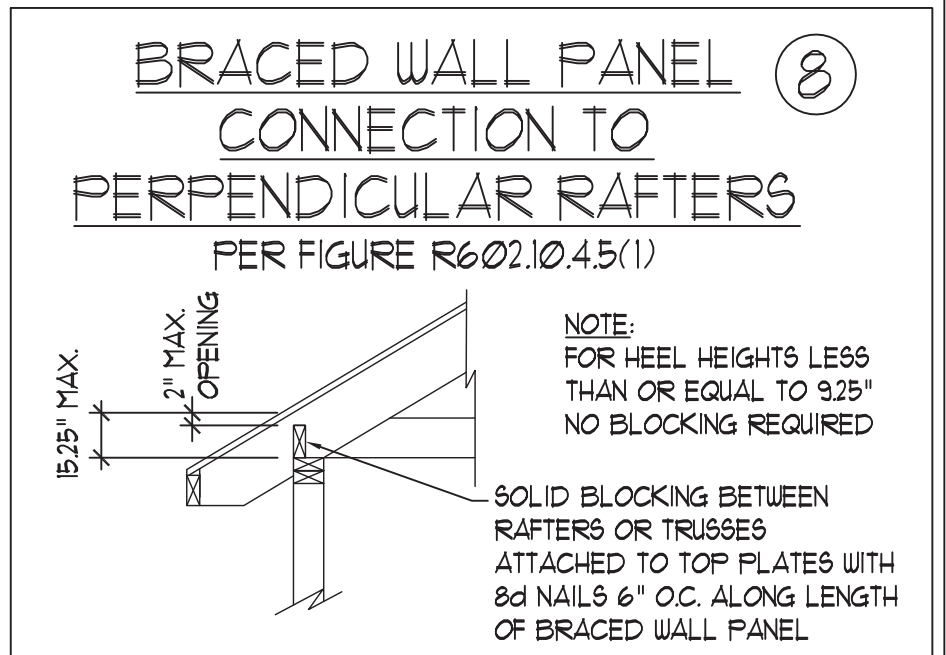
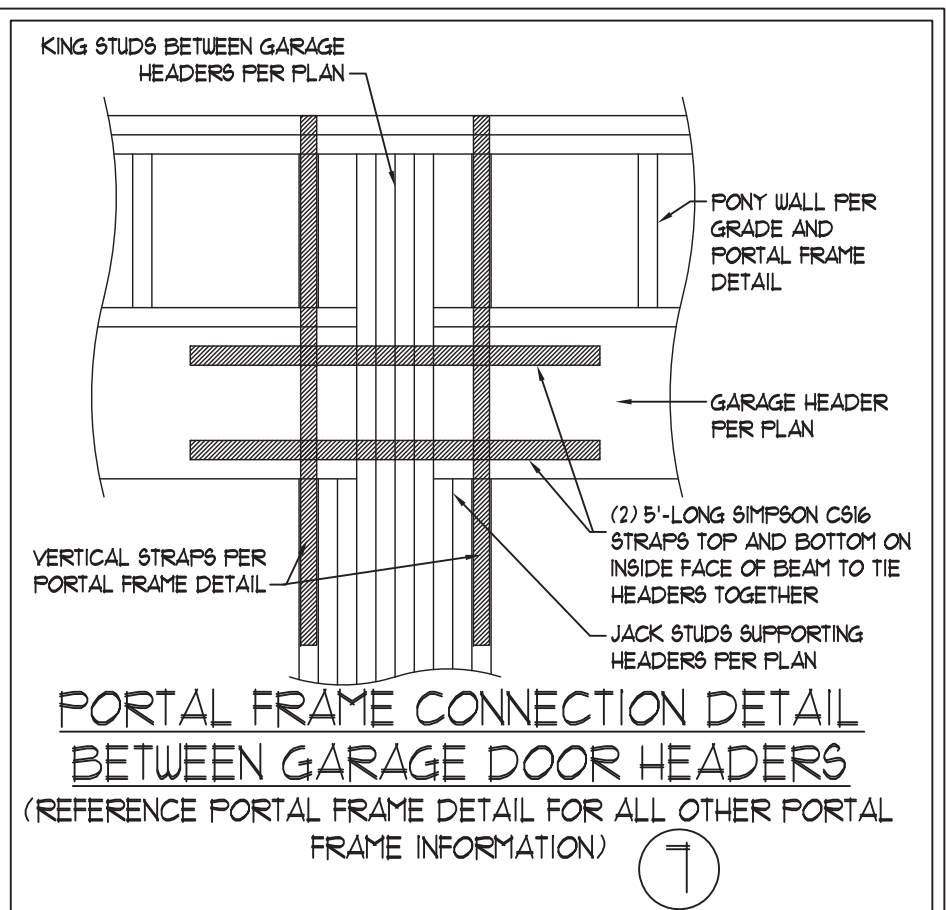

**BRACED WALL PANEL CONNECTION TO PERPENDICULAR RAFTERS ⑧**  
 PER FIGURE R602.10.4.5(1)

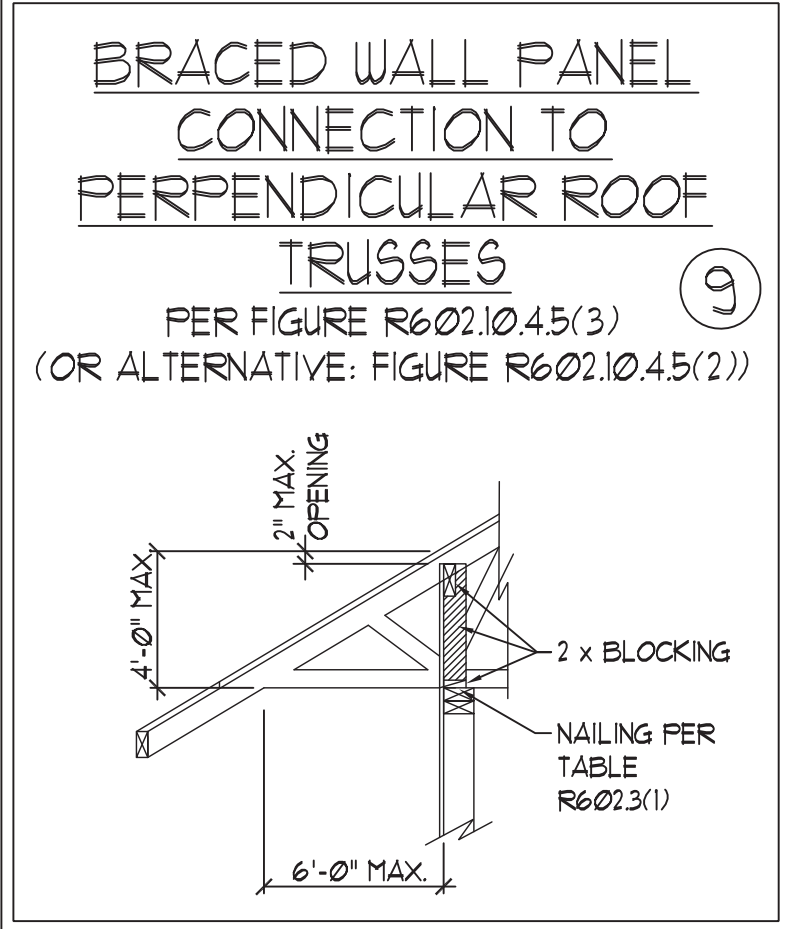

**BRACED WALL PANEL CONNECTION TO PERPENDICULAR ROOF TRUSSES ⑨**  
 PER FIGURE R602.10.4.5(3) (OR ALTERNATIVE: FIGURE R602.10.4.5(2))

This sealed page is to be used in conjunction with a full plan set engineered by J.S. Thompson Engineering, Inc. only. Use of this individual sealed page within architectural pages or shop drawings by others is a punishable offense under N.C. Statute § 89C-23

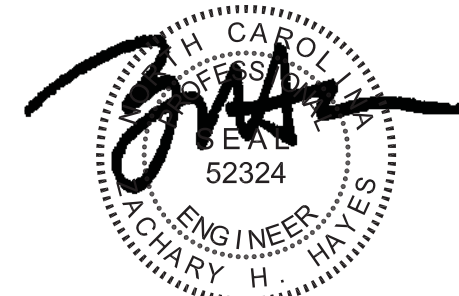

7/30/2021

**J.S. THOMPSON ENGINEERING, INC.**  
 606 WADE AVE., SUITE 104 RALEIGH, NC 27605  
 PHONE: (919) 789-9919 FAX: (919) 789-9921  
 N.C. LICENSE NO.: C-1733

**WALL BRACING NOTES AND DETAILS**

DATE: MAY 18, 2020  
 SCALE: 1/4" = 1'-0"  
 DRAWN BY: JST  
 ENGINEERED BY: JST

BRACED WALL NOTES AND DETAILS AND PF DETAIL



**GENERAL NOTES**

- ENGINEER'S SEAL APPLIES ONLY TO STRUCTURAL COMPONENTS INCLUDING ROOF RAFTERS, HIPS, VALLEYS, RIDGES, FLOORS, WALLS, BEAMS, HEADERS, COLUMNS, CANTILEVERS, OFFSET LOAD BEARING WALLS, PIERS, GIRDER SYSTEM AND FOOTING. ENGINEER'S SEAL DOES NOT CERTIFY DIMENSIONAL ACCURACY OF ARCHITECTURAL LAYOUT INCLUDING ROOF. ENGINEER'S SEAL DOES NOT APPLY TO I-JOIST OR FLOOR/ROOF TRUSS LAYOUT DESIGN AND ACCURACY.
- ALL CONSTRUCTION SHALL CONFORM TO THE LATEST REQUIREMENTS OF THE NORTH CAROLINA RESIDENTIAL CODE (NRC), 2018 EDITION, PLUS ALL LOCAL CODES AND REGULATIONS. THE STRUCTURAL ENGINEER IS NOT RESPONSIBLE FOR, AND WILL NOT HAVE CONTROL OF, CONSTRUCTION MEANS, METHODS, TECHNIQUES, SEQUENCES OR PROCEDURES, OR SAFETY PRECAUTIONS AND PROGRAMS IN CONNECTION WITH THE CONSTRUCTION WORK. NOR WILL THE ENGINEER BE RESPONSIBLE FOR THE CONTRACTOR'S FAILURE TO CARRY OUT THE CONSTRUCTION WORK IN ACCORDANCE WITH THE CONTRACT DOCUMENTS.
- STRUCTURAL DESIGN BASED ON THE PROVISIONS OF THE NRC, 2018 EDITION (R301.4 - R301.7)

DESIGN CRITERIA:	LIVE LOAD (PSF)	DEAD LOAD (PSF)	DEFLECTION (IN)
ATTIC WITH LIMITED STORAGE	20	10	L/240 (L/360 w/ BRITTLE FINISHES)
ATTIC WITHOUT STORAGE	10	10	L/360
DECKS	40	10	L/360
EXTERIOR BALCONIES	40	10	L/360
FIRE ESCAPES	40	10	L/360
HANDRAILS/GUARDRAILS	200 LB OR 50 (PLF)	10	L/360
PASSENGER VEHICLE GARAGE	50	10	L/360
ROOMS OTHER THAN SLEEPING ROOM	40	10	L/360
SLEEPING ROOMS	30	10	L/360
STAIRS	40	10	L/360
WIND LOAD	(BASED ON TABLE R301.2(4) WIND ZONE AND EXPOSURE)		
GROUND SNOW LOAD: P <sub>g</sub>	20 (PSF)		

- I-JOIST SYSTEMS DESIGNED WITH 12 PSF DEAD LOAD AND DEFLECTION (IN) OF L/480
  - FLOOR TRUSS SYSTEMS DESIGNED WITH 15 PSF DEAD LOAD
- FOR 15 AND 120 MPH WIND ZONES, FOUNDATION ANCHORAGE IS TO COMPLY WITH SECTION R403.1.6 OF THE NRC, 2018 EDITION. FOR 130 MPH, 140 MPH, AND 150 MPH WIND ZONES, FOUNDATION ANCHORAGE IS TO COMPLY WITH SECTION 450.4 OF THE NRC, 2018 EDITION.
  - ENERGY EFFICIENCY COMPLIANCE AND INSULATION VALUES OF THE BUILDING TO BE IN ACCORDANCE WITH CHAPTER II OF THE NRC, 2018 EDITION.

**FOOTING AND FOUNDATION NOTES**

- FOUNDATION DESIGN BASED ON A MINIMUM ALLOWABLE BEARING CAPACITY OF 2000 PSF. CONTACT GEOTECHNICAL ENGINEER IF BEARING CAPACITY IS NOT ACHIEVED.
- FOR ALL CONCRETE SLABS AND FOOTINGS, THE AREA WITHIN THE PERIMETER OF THE BUILDING ENVELOPE SHALL HAVE ALL VEGETATION TOP SOIL AND FOREIGN MATERIAL REMOVED. FILL MATERIAL SHALL BE FREE OF VEGETATION AND FOREIGN MATERIAL. THE FILL SHALL BE COMPACTED TO ASSURE UNIFORM SUPPORT OF THE SLAB, AND EXCEPT WHERE APPROVED, THE FILL DEPTHS SHALL NOT EXCEED 24" FOR CLEAN SAND OR GRAVEL. A 4" THICK BASED COURSE CONSISTING OF CLEAN GRADED SAND OR GRAVEL SHALL BE PLACED. A BASE COURSE IS NOT REQUIRED WHERE A CONCRETE SLAB IS INSTALLED ON WELL-DRAINED OR SAND-GRAVEL MIXTURE SOILS CLASSIFIED AS GROUP 1, ACCORDING TO THE UNITED SOIL CLASSIFICATION SYSTEM IN ACCORDANCE WITH TABLE R405.1 OF THE NRC, 2018 EDITION.
- PROPERLY DEWATER EXCAVATION PRIOR TO POURING CONCRETE WHEN BOTTOM OF CONCRETE SLAB IS AT OR BELOW WATER TABLE. IF APPLICABLE, 3/4" - 1" DEEP CONTROL JOINTS ARE TO BE SAUED WITHIN 4 TO 12 HOURS OF CONCRETE FINISHING AND WALL LOCATIONS HAVE BEEN MARKED. ADJUST WHERE NECESSARY.
- CONCRETE SHALL CONFORM TO SECTION R402.2 OF THE NRC, 2018 EDITION. CONCRETE REINFORCING STEEL TO BE ASTM A615 GRADE 60. WELDED WIRE FABRIC TO BE ASTM A185. MAINTAIN A MINIMUM CONCRETE COVER AROUND REINFORCING STEEL OF 3" IN FOOTINGS AND 1 1/2" IN SLABS. FOR POURED CONCRETE WALLS, CONCRETE COVER FOR REINFORCING STEEL MEASURED FROM THE INSIDE FACE OF THE WALL SHALL NOT BE LESS THAN 3/4". CONCRETE COVER FOR REINFORCING STEEL MEASURED FROM THE OUTSIDE FACE OF THE WALL SHALL NOT BE LESS THAN 1 1/2" FOR #5 BARS OR SMALLER, AND NOT LESS THAN 2" FOR #6 BARS OR LARGER.
- MASONRY UNITS TO CONFORM TO ACE 530/ASCE 5/TMS 402. MORTAR SHALL CONFORM TO ASTM C270.
- THE UNSUPPORTED HEIGHT OF MASONRY PIERS SHALL NOT EXCEED FOUR TIMES THEIR LEAST DIMENSION FOR UNFILLED HOLLOW CONCRETE MASONRY UNITS AND TEN TIMES THEIR LEAST DIMENSION FOR SOLID OR SOLID FILLED PIERS. PIERS MAY BE FILLED SOLID WITH CONCRETE OR TYPE M OR S MORTAR. PIERS AND WALLS SHALL BE CAPPED WITH 8" OF SOLID MASONRY.
- THE CENTER OF EACH OF THE PIERS SHALL BEAR IN THE MIDDLE THIRD OF ITS RESPECTIVE FOOTING. EACH GIRDER SHALL BEAR IN THE MIDDLE THIRD OF THE PIERS.
- ALL CONCRETE AND MASONRY FOUNDATION WALLS ARE TO BE CONSTRUCTED IN ACCORDANCE WITH THE PROVISIONS OF SECTION R404 OF THE NRC, 2018 EDITION OR IN ACCORDANCE WITH ACI 318, ACI 332, NCMA TR68-A OR ACE 530/ASCE 5/TMS 402. MASONRY FOUNDATION WALLS ARE TO BE REINFORCED PER TABLE R404.1(1), R404.1(2), R404.1(3), OR R404.1(4) OF THE NRC, 2018 EDITION. CONCRETE FOUNDATION WALLS ARE TO BE REINFORCED PER TABLE R404.1(5) OF THE NRC, 2018 EDITION. STEP CONCRETE FOUNDATION WALLS TO 2 x 6 FRAMED WALLS AT 16" O.C. WHERE GRADE PERMITS (UNO).



This sealed page is to be used in conjunction with a full plan set engineered by J.S. Thompson Engineering, Inc. only. Use of this individual sealed page within architectural pages or shop drawings by others is a punishable offense under N.C. Statute § 89C-23

**FRAMING NOTES**

- ALL FRAMING LUMBER SHALL BE #2 GFF MINIMUM (F<sub>b</sub> = 875 PSF, F<sub>v</sub> = 375 PSF, E = 1600000 PSF) UNLESS NOTED OTHERWISE (UNO). ALL TREATED LUMBER SHALL BE #2 SYP MINIMUM (F<sub>b</sub> = 975 PSF, F<sub>v</sub> = 175 PSF, E = 1600000 PSF) UNLESS NOTED OTHERWISE (UNO).
- LAMINATED VENEER LUMBER (LVL) SHALL HAVE THE FOLLOWING MINIMUM PROPERTIES: F<sub>b</sub> = 2600 PSF, F<sub>v</sub> = 285 PSF, E = 1900000 PSF. LAMINATED STRAND LUMBER (LSL) SHALL HAVE THE FOLLOWING MINIMUM PROPERTIES: F<sub>b</sub> = 2325 PSF, F<sub>v</sub> = 310 PSF, E = 1950000 PSF. PARALLEL STRAND LUMBER (PSL) UP TO 1" DEPTH SHALL HAVE THE FOLLOWING MINIMUM PROPERTIES: F<sub>c</sub> = 2500 PSF, E = 1800000 PSF. PARALLEL STRAND LUMBER (PSL) MORE THAN 1" DEPTH SHALL HAVE THE FOLLOWING MINIMUM PROPERTIES: F<sub>c</sub> = 2900 PSF, E = 2000000 PSF. INSTALL ALL CONNECTIONS PER MANUFACTURER'S SPECIFICATIONS.
- STRUCTURAL STEEL SHALL CONFORM TO THE FOLLOWING ASTM SPECIFICATIONS
 

A. W AND WT SHAPES:	ASTM A992
B. CHANNELS AND ANGLES:	ASTM A36
C. PLATES AND BARS:	ASTM A36
D. HOLLOW STRUCTURAL SECTIONS:	ASTM A500 GRADE B
E. STEEL PIPE:	ASTM A53, GRADE B, TYPE E OR S

- STEEL BEAMS SHALL BE SUPPORTED AT EACH END WITH A MINIMUM BEARING LENGTH OF 3 1/2" AND FULL FLANGE WIDTH (UNO). PROVIDE SOLID BEARING FROM BEAM SUPPORT TO FOUNDATION. BEAMS SHALL BE ATTACHED AT THE BOTTOM FLANGE TO EACH SUPPORT AS FOLLOWS (UNO):
 

A. WOOD FRAMING	(2) 1/2" DIA. x 4" LONG LAG SCREWS
B. CONCRETE	(2) 1/2" DIA. x 4" WEDGE ANCHORS
C. MASONRY (FULLY GROUTED)	(2) 1/2" DIA. x 4" LONG SIMPSON TITEN HD ANCHORS

LATERAL SUPPORT IS CONSIDERED ADEQUATE PROVIDING THE JOISTS ARE TOE NAILED TO THE 2x NAILER ON TOP OF THE STEEL BEAM, AND THE 2x NAILER IS SECURED TO THE TOP OF THE STEEL BEAM w/ (2) ROWS OF SELF TAPPING SCREWS @ 16" O.C. OR (2) ROWS OF 1/2" DIAMETER BOLTS @ 16" O.C. IF 1/2" BOLTS ARE USED TO FASTEN THE NAILER, THE STEEL BEAM SHALL BE FABRICATED w/ (2) ROWS OF 3/16" DIAMETER HOLES @ 16" O.C.

- SQUARES DENOTE POINT LOADS WHICH REQUIRE SOLID BLOCKING TO GIRDER OR FOUNDATION. SHADED SQUARES DENOTE POINT LOADS FROM ABOVE WHICH REQUIRE SOLID BLOCKING TO SUPPORTING MEMBER BELOW.
- ALL LOAD BEARING HEADERS TO CONFORM TO TABLE R602.1(1) AND R602.1(2) OF THE NRC, 2018 EDITION OR BE (2) 2 x 6 WITH (1) JACK AND (1) KING STUD EACH END (UNO) WHICHEVER IS GREATER ALL HEADERS TO BE SECURED TO EACH JACK STUD WITH (4) 8d NAILS. ALL BEAMS TO BE SUPPORTED WITH (2) STUDS AT EACH BEARING POINT (UNO). INSTALL KING STUDS PER SECTION R602.1.5 OF THE NORTH CAROLINA RESIDENTIAL CODE, 2018 EDITION.
- ALL BEAMS, HEADERS, OR GIRDER TRUSSES PARALLEL TO WALL ARE TO BEAR FULLY ON (1) JACK OR (2) STUDS MINIMUM OR THE NUMBER OF JACKS OR STUDS NOTED. ALL BEAMS OR GIRDER TRUSSES PERPENDICULAR TO WALL AND SUPPORTED BY (3) STUDS OR LESS ARE TO HAVE 1 1/2" MINIMUM BEARING (UNO). ALL BEAMS OR GIRDER TRUSSES PERPENDICULAR TO WALL AND SUPPORTED BY MORE THAN (3) STUDS OR OTHER NOTED COLUMN ARE TO BEAR FULLY ON SUPPORT COLUMN FOR ENTIRE WALL DEPTH (UNO). BEAM ENDS THAT BUTT INTO ONE ANOTHER ARE TO EACH BEAR EQUAL LENGTHS (UNO).
- FLITCH BEAMS SHALL BE BOLTED TOGETHER USING 1/2" DIAMETER BOLTS (ASTM A307) WITH WASHERS PLACED AT THREADED END OF BOLT. BOLTS SHALL BE SPACED AT 24" CENTERS (MAXIMUM), AND STAGGERED AT TOP AND BOTTOM OF BEAM (2" EDGE DISTANCE), WITH (2) BOLTS LOCATED AT 6" FROM EACH END (UNO).
- ALL I-JOIST OR TRUSS LAYOUTS ARE TO BE IN COMPLIANCE WITH THE OVERALL DESIGN SPECIFIED ON THE PLANS. ALL DEVIATIONS ARE TO BE BROUGHT TO THE ATTENTION OF THE ENGINEER OF RECORD PRIOR TO INSTALLATION.
- BRACED WALL PANELS SHALL BE CONSTRUCTED ACCORDING TO THE NORTH CAROLINA RESIDENTIAL CODE 2018 EDITION WALL BRACING CRITERIA. THE AMOUNT, LENGTH, AND LOCATION OF BRACING SHALL COMPLY WITH ALL APPLICABLE TABLES IN SECTION R602.10.
- PROVIDE DOUBLE JOIST UNDER ALL WALLS PARALLEL TO FLOOR JOISTS. PROVIDE SUPPORT UNDER ALL WALLS PARALLEL TO FLOOR TRUSSES OR I-JOISTS PER MANUFACTURER'S SPECIFICATIONS. INSTALL BLOCKING BETWEEN JOISTS OR TRUSSES FOR POINT LOAD SUPPORT FOR ALL POINT LOADS ALONG OFFSET LOAD LINES.
- FOR ALL HEADERS SUPPORTING BRICK VENEER THAT ARE LESS THAN 8'-0" IN LENGTH, REST A 6" x 4" x 5/16" STEEL ANGLE WITH 6" MINIMUM EMBEDMENT AT SIDES FOR BRICK SUPPORT (UNO). FOR ALL HEADERS 8'-0" AND GREATER IN LENGTH, BOLT A 6" x 4" x 5/16" STEEL ANGLE TO HEADER WITH 1/2" LAG SCREWS AT 12" O.C. STAGGERED FOR BRICK SUPPORT. FOR ALL BRICK SUPPORT AT ROOF LINES, BOLT A 6" x 4" x 5/16" STEEL ANGLE TO (2) 2 x 10 BLOCKING INSTALLED w/ (4) 12d NAILS EA. PLY BETWEEN WALL STUDS WITH (2) ROWS OF 1/2" LAG SCREWS AT 12" O.C. STAGGERED AND IN ACCORDANCE WITH SECTION R103.2(1) OF THE NRC, 2018 EDITION.
- FOR STICK FRAMED ROOFS: CIRCLES DENOTE (3) 2 x 4 POSTS FOR ROOF MEMBER SUPPORT. HIP SPLICES ARE TO BE SPACED A MINIMUM OF 8'-0". FASTEN MEMBERS WITH THREE ROWS OF 12d NAILS AT 16" O.C. FRAME DORMER WALLS ON TOP OF DOUBLE OR TRIPLE RAFTERS AS SHOWN (UNO).
- FOR TRUSSED ROOFS: FRAME DORMER WALLS ON TOP OF 2 x 4 LADDER FRAMING AT 24" O.C. BETWEEN ADJACENT ROOF TRUSSES. STICK FRAME OVER-FRAMED ROOF SECTIONS WITH 2 x 8 RIDGES, 2 x 6 RAFTERS AT 16" O.C. AND FLAT 2 x 10 VALLEYS (UNO).
- ALL 4 x 4 AND 6 x 6 POSTS TO BE INSTALLED WITH 100 LB CAPACITY UPLIFT CONNECTORS TOP AND BOTTOM (UNO). POSTS MAY BE SECURED USING ONE SIMPSON H6 OR L912 UPLIFT CONNECTOR FASTENED TO THE BAND AT THE BOTTOM AND THE BEAM AT THE TOP OF EACH POST. ONE 16" SECTION OF SIMPSON CS16 COIL STRAPPING WITH (8) 8d HDG NAILS AT EACH END MAY BE USED IN LIEU OF EACH TWIST STRAP IF DESIRED. FOR MASONRY OR CONCRETE FOUNDATION USE SIMPSON POST BASE.

**J.S. THOMPSON ENGINEERING, INC**  
 606 WADE AVE., SUITE 104 RALEIGH, NC 27605  
 PHONE: (919) 789-9919 FAX: (919) 789-9921  
 N.C. LICENSE NO.: C-1733

**STANDARD STRUCTURAL NOTES**

DATE: OCTOBER 29, 2019  
 SCALE: 1/4" = 1'-0"  
 DRAWN BY: JST  
 ENGINEERED BY: JST

SHEET:  
 STRUCTURAL NOTES