

Products					
Net Qty	Plies	Product	Length	PlotID	
9	1	11-7/8" BCI@ 4500s-1.8	21' 1 3/4"	FJ-1	
5	1	11-7/8" BCI@ 4500s-1.8	16' 8"	FJ-2	
9	1	11-7/8" BCI@ 4500s-1.8	14' 8"	FJ-3	
13	1	11-7/8" BCI@ 4500s-1.8	14' 7 1/4"	FJ-4	
2	1	11-7/8" BCI@ 4500s-1.8	11' 3"	FJ-5	
1	1	11-7/8" BCI@ 4500s-1.8	10' 3 1/4"	FJ-6	
12	1	1" x 11-7/8" BC RIM BOARD OSB	12' 0"	Rim1	
19	1	11-7/8" BCI@ 4500s-1.8	2' 0"	Bk1	

TOPSAIL
SEAL DATE 10-26-17
CRAWL I-JOIST LAYOUT

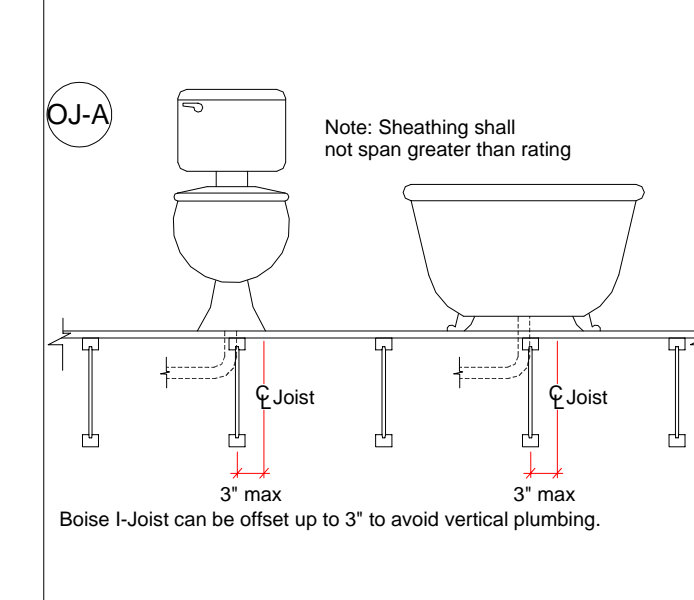
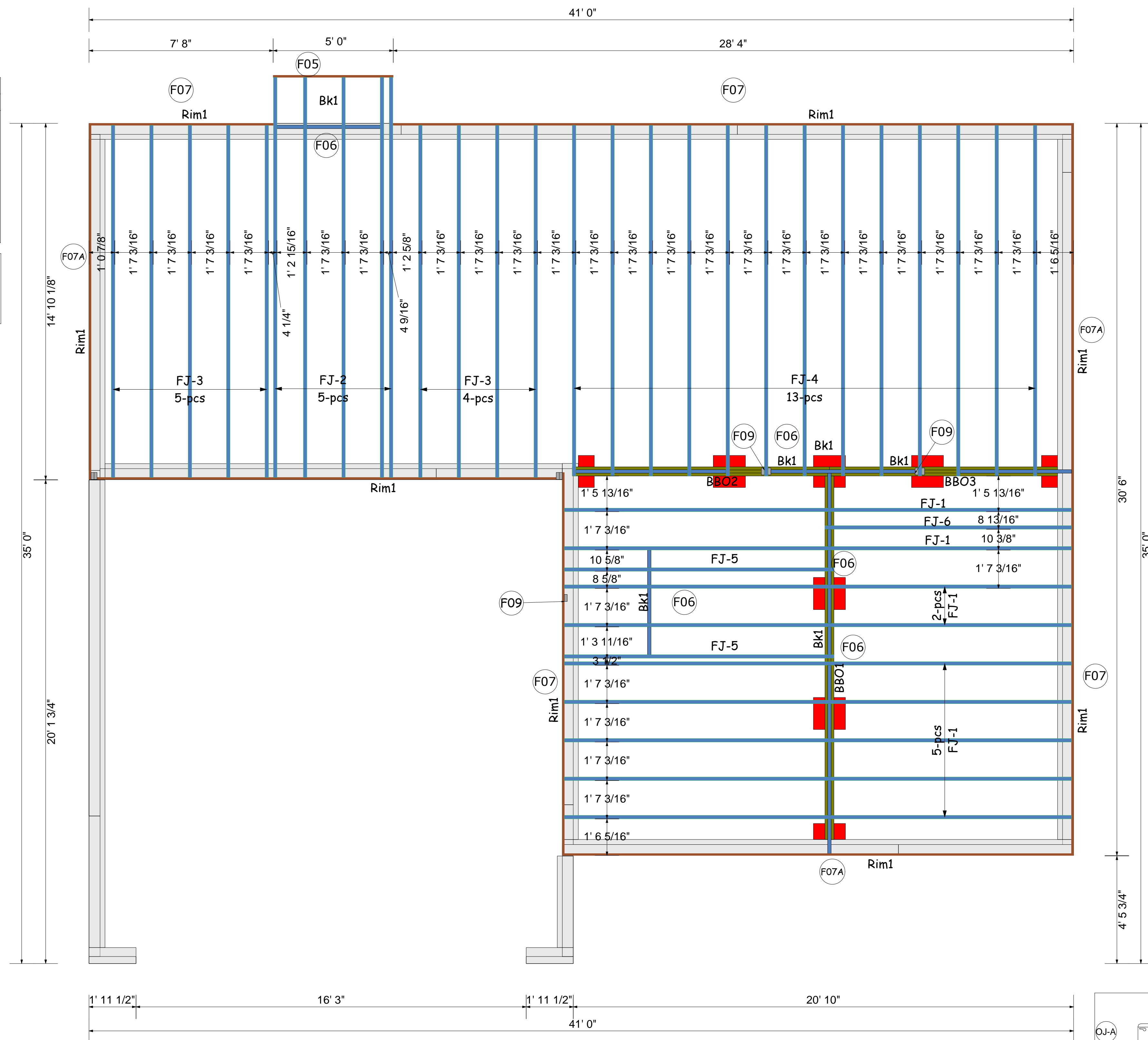

This layout and associated materials list has been prepared based on project plans and/or information provided to Builders FirstSource (BFS). It remains the responsibility of the builder, architect, designer, or other responsible persons to review this information to assure that it is appropriate, accurate, complete and complies with applicable building codes.

- GENERAL NOTES:**
- 1.) READ THE INSTALLATION GUIDE BEFORE FRAMING.
 - 2.) ALL WALLS SHOWN ARE LOAD BEARING UNLESS NOTED OTHERWISE. WALLS NOT SHOWN ARE CONSIDERED NON-LOAD BEARING.
 - 3.) UNLESS STATED OTHERWISE ALL CEILING & ROOF LOADS BRACE DIRECTLY TO LOAD BEARING WALLS SUPPORTED BY FOUNDATION.
 - 4.) CONTACT BUILDERS FIRSTSOURCE BEFORE MAKING ANY ALTERATIONS OR ADJUSTMENTS...FAILURE TO DO SO MAY RESULT IN COSTLY REPAIRS.

H & H HOMES
TOPSAIL - SWP-195
CRAWL EWP PLACEMENT PLAN
Builders FirstSource, Central Carolina Markets
DRAWN BY: CORY D DRIETZ DATE: 26DEC17
SCALE: NOT TO SCALE JOB NUMBER:

MINIMUM DESIGN DATA
LIVE LOAD 40 PSF
DEAD LOAD 10 PSF
TOTAL LOAD 50 PSF
DOL = 100%
DEFLECTION CRITERIA
L/480 (MINIMUM)
ARCHITECTURAL PLAN DATE
7-6-16
REVISED ARCH. PLAN DATE