

TrueHomes

IT'S ALL ABOUT U



TrueHomes
IT'S ALL ABOUT U
2649 Breckridge Centre Dr.
Suite 104
Monroe, N.C. 28110
704-271-1191

HEADER SCHEDULE

ALL INTERIOR BEARING AND EXTERIOR WALLS

- SPANS UP TO 3'-6" -- (2) 2x8's
- SPANS 3'-6" TO 6'-6" -- (2) 2x10's
- SPANS 6'-6" OR MORE -- SEE PLAN

**** SOUTH CAROLINA SPECIFIC NOTE ****
ALL OPENINGS IN THERMAL ENVELOPE MUST HAVE INSULATED HEADER PER CODE

EXTERIOR HINGED DOOR SCHEDULE

DOOR WIDTH		DOOR HEIGHT R.O.		
PLAN I.D.	R.O. WIDTH	8FT CEILING	9FT CEILING	10FT CEILING
3/0	3'-2 1/2"	82'-1/2"	82'-1/2"	98'-1/2"
2/8	2'-10 1/2"			
5/0	5'-3 5/8"			
5/4	5'-7 5/8"			
6/0	6'-3 5/8"			
SLIDING PATIO DOORS				
5/0	60'-1/8"	80'-1/2"	80'-1/2"	96'-1/2"
6/0	72'-1/8"	80'-1/2"	80'-1/2"	96'-1/2"

INTERIOR HINGED DOOR SCHEDULE

DOOR WIDTH		DOOR HEIGHT R.O.		
PLAN I.D.	R.O. WIDTH	8FT CEILING	9FT CEILING	10FT CEILING
1/4	1'-6"	82'-1/2" NOMINAL DOOR HEIGHT + 2'-1/2"	82'-1/2" NOMINAL DOOR HEIGHT + 2'-1/2"	98'-1/2" NOMINAL DOOR HEIGHT + 2'-1/2"
1/6	1'-8"			
1/8	1'-10"			
2/0	2'-2"			
2/4	2'-6"			
2/6	2'-8"			
2/8	2'-10"			
2/10	3'-0"			
3/0	3'-2"			
4/0	4'-2"			
5/0	5'-2"			
6/0	6'-2"			

◊ EXTERIOR DOOR ○ INTERIOR DOOR

INTERIOR PASS THRU SCHEDULE

FRAMED OPENING DIMENSIONS		
WALL HEIGHT	R.O. WIDTH	R.O. HEIGHT
8'-1	1/8" PLAN I.D. + 2"	82'-1/2"
9'-1	1/8" PLAN I.D. + 2"	94'-1/2"
10'-1	1/8" PLAN I.D. + 2"	98'-1/2"

ROUGH OPENING HEIGHTS ARE FOR DO, CO, & AO OPENINGS. SHIM HEIGHTS AS NEEDED TO MATCH INTERIOR HINGED DOOR CASING

INTERIOR DOORWAY OPENINGS:
DO = DRYWALL OPENING
CO = CASING OPENING
AO = ARCHED OPENING

GENERAL NOTES

- PLANS PERMITTED IN NORTH CAROLINA ARE DESIGNED TO MEET THE 2018 NORTH CAROLINA RESIDENTIAL BUILDING CODE, AS ISSUED BY THE STATE OF NORTH CAROLINA, AND PLANS PERMITTED IN SOUTH CAROLINA DESIGNED TO MEET 2018 INTERNATIONAL RESIDENTIAL BUILDING CODE AS ISSUED BY THE STATE OF SOUTH CAROLINA, WITH MODIFICATIONS AS REQUIRED TO MEET LOCAL BUILDING CODES FOR EACH APPLICABLE JURISDICTION.
- DO NOT SCALE DIMENSIONS FROM PRINTS. USE DIMENSIONS GIVEN OR CONSULT ARCHITECTURAL SERVICES DEPARTMENT FOR FURTHER CLARIFICATION.
- ALL DIMENSIONS ARE FROM WALL FRAMING (FACE OF STUD), NO FINISHED DIMENSIONS ARE GIVEN U.N.O.
- PROVIDE 2 STUDS BETWEEN ALL WINDOWS.(TYP)
- ACCESS DOORS BETWEEN HOUSE AND GARAGE AREAS TO BE 20-MINUTE FIRE RATED.
- ALL INTERIOR NON-LOAD BEARING WALLS TO BE 2x4 STUDS @ 24" O.C. (U.N.O.). OR AS SPECIFIED PER COMMUNITY SPECS & MUNICIPALITY REQUIREMENTS.
- ALL STRUCTURAL FRAMING LUMBER EXPOSED DIRECTLY TO THE WEATHER OR BEARING DIRECTLY ON MASONRY OR CONCRETE SHALL BE TREATED. ALL WOOD IN CONTACT WITH THE GROUND MUST BE GROUND-CONTACT APPROVED. ALL WOOD EXPOSED DIRECTLY TO THE WEATHER SHALL BE PROTECTED TO PREVENT THE OCCURRENCE OF ROT.
- ALL ANGLED WALLS ARE AT 45 DEGREES UNLESS NOTED OTHERWISE.
- REFER TO QUALITY STANDARDS AND/OR MANUFACTURER SPECS FOR WINDOW ROUGH OPENING SIZES. SEE ELEVATIONS FOR WINDOW HEADER HEIGHTS (U.N.O.).
- PROVIDE BLOCKING ABOVE WINDOWS AND DOORS 16" O.C.
- PROVIDE EXTRA STUDS AS INDICATED AT BEAM BEARING LOCATIONS.
- WALLS TO BE FRAMED WITH STUDS AT 16" O.C. AT KITCHEN WALLS WITH CABINETS AND AT TUB/SHOWER LOCATIONS (PER MANUF.).
- ALL COMMON CEILING BETWEEN GARAGE TO HOUSE PROVIDE 5/8" TYPE X GWB PER GARAGE SEPARATION REQUIREMENTS PER CODE. ALL JOINTS TO BE TAPED & MUDDER FOR FIRE SEPARATION. ALL STRUCTURES SUPPORTING FLOOR/CEILING ASSEMBLIES USED FOR SEPARATION REQUIRE NOT LESS THAN 1/2" GYP OR EQ. PER SECTION R302.6
- SEPARATE GARAGE FROM ATTIC WITH 5/8" TYPE X GWB SCUTTLE MINIMUM AND 2X SCUTTLE FRAMING MATERIAL.
- HEEL HEIGHTS: SEE ELEVATIONS SHEETS FOR TOP OF FASCIA DIMENSIONS TO GATHER PROPER HEEL HEIGHT REQUIREMENTS.
- PROVIDE AND INSTALL LOCALLY CERTIFIED SMOKE DETECTORS AND CARBON MONOXIDE DETECTORS AS REQUIRED BY NATIONAL FIRE PROTECTION ASSOCIATION AND MEETING THE REQUIREMENTS OF ALL GOVERNING CODES AND PER MANUFACTURER SPECS.
- STAIR TREAD DESIGN TO BE VERIFIED WITH SELECTIONS AND PO'S.
- PROVIDE 1 1/2" FLAT WALL FRAMING FOR ALL HVAC CHASES UNLESS NOTED OTHERWISE. SEE FRAMING SHEET GN FOR ADDITIONAL NOTES PER LOCAL CODES.
- FOR TRADITIONS, ELEMENTS, INTEGRITY, AND TRIBUTE SERIES, DOORS SHOULD BE LOCATED 4" OFF ADJACENT WALLS OR CENTERED IN THE WALL UNLESS NOTED OTHERWISE. DESIGNER SERIES SHOULD BE LOCATED 6" OFF ADJACENT WALLS OR CENTERED IN THE WALL UNLESS NOTED OTHERWISE.
- ALL HOMES TREATED WITH BORA-CARE TERMITE TREATMENT.
- SMURF DOORS ARE 21 1/2" x 39" NOMINAL (R.O. 22 1/2" x 40").
- SHEATH WALLS AND CEILINGS w/ OSB PER SPECS. IN FURN. ROOM LOCATIONS
- ALL PLANS ARE GENERATED WITH THE AID OF A COMPUTER AIDED DRAFTING SYSTEM.
- DIMENSION AND NOTATIONS ON PLANS HAVE PREFERENCE OVER GRAPHIC DEPICTIONS AND SHOULD BE UTILIZED TO SETTLE ANY DISCREPANCIES - ANY DISCREPANCIES FOUND SHOULD BE FORWARDED TO THE ARCHITECTURAL SERVICES DEPARTMENT FOR RESOLUTION.
- TYPICAL FOUNDATION AND ENGINEERING CONSTRUCTION DETAILS ARE SHOWN IN RESPECTIVE PLANS. TYPICAL DETAILS SHALL APPLY TO ALL SITUATIONS OCCURRING ON THE PLAN THAT ARE THE SAME OR SIMILAR TO THOSE SPECIALLY DETAILED. THE APPLICABILITY OF THE DETAIL TO ITS LOCATION ON THE DRAWINGS CAN BE DETERMINED BY THE TITLE OF THE DETAIL. SUCH DETAILS SHALL APPLY WITHER OR NOT THEY ARE REFERENCED AT EACH LOCATION.
- ALL CONSTRUCTION SPECIFICATION NOT COVERED ON THIS SHEET, OR IN PLAN SETS AND GENERAL SPECIFICATIONS, ARE TO MEET ALL APPLICABLE STATE AND LOCAL BUILDING CODES.
- HOUSE CONSTRUCTION IS TYPICAL 2X4 STUDS AT 16" O.C. AT ALL EXTERIOR WALLS UNLESS OTHERWISE NOTED. WALLS THAT ARE TO BE BALLOON FRAMED OR CONSTRUCTED WITH 2X6 STUDS WILL BE NOTED AS SUCH. ALL BASEMENT FRAMED WALLS TO BE 2X4 STUDS FOR ONE-STORY PLANS AND 2X6 STUDS FOR LOAD BEARING WALLS ON TWO-STORY PLANS UNLESS OTHERWISE NOTED.
- PLANS ARE GENERATED FROM A COMMON GRAPHIC DATABASE WITH MODIFICATIONS AS REQUIRED TO ADAPT PLANS TO LOCAL BUILDING CONDITIONS AND SPECS FOR EACH LOCALITY.
- TRUE HOMES RESERVES THE RIGHT TO MAKE MODIFICATIONS TO FLOOR PLANS, DIMENSIONS, MATERIALS, AND SPECIFICATIONS WITHOUT NOTICE. THESE DRAWINGS ARE FOR THE PURPOSE OF CONVEYING AN ARCHITECTURAL CONCEPT ONLY.

RALEIGH DESIGN CRITERIA

- DESIGN LOADS ARE ALL DEAD LOADS PLUS:
 - SLEEPING ROOMS.....30 PSF
 - ALL OTHER FLOORS.....40 PSF
 - BALCONIES.....40 PSF
 - ATTIC FLOOR LIVE LOADING WITH THE FOLLOWING:
 - AREA ACCESSIBLE BY STAIRS.....40 PSF
 - ROOF SLOPES >3:12.....20 PSF
 - ROOF SLOPES <3:12.....10 PSF
 - ROOF LIVE LOAD.....20 PSF
 - WIND LOAD.....115 MPH
 - SNOW LOAD.....20 PSF
 - SEISMIC ZONE.....B
 - DESIGN IS COMPLIANT WITH 2018 NCRG ENERGY CODE N1102.2 PRESCRIPTIVE FOR CLIMATE ZONE 4A

REVISION LOG

1. DATE:	DRAWN BY:
2. DATE:	DRAWN BY:
3. DATE:	DRAWN BY:
4. DATE:	DRAWN BY:

THE 'JASPER'

WALKER GROVE

LOT 13
TBD WALKER GROVE LANE
LILLINGTON, NC 27546

COMMUNITY SPECS

- MONO FOUNDATION
- VINYL SIDING / VINYL SOFFIT
- 2 CAR GARAGE

SQUARE FOOTAGE

FIRST FLOOR	1120 SQ.FT.
SECOND FLOOR	1262 SQ.FT.
TOTAL LIVABLE	2382 SQ.FT.
FRONT COVERED PORCH	98 SQ.FT.
2-CAR GARAGE	450 SQ.FT.
REAR COVERED PORCH	130 SQ.FT.
OVERALL HT. (FF to Ridge)	28'-11"
PLATE HEIGHT(S)	9' / 8'

ELEMENTS

HELP HOTLINES	TABLE OF CONTENTS
"WHEN IN DOUBT, GIVE US A SHOUT"	CS COVER SHEET
TRUE BUILDER: (To be filled in by Builder on site)	A2.1 FIRST FLOOR PLAN
NAME: _____	A2.2 SECOND FLOOR PLAN
NUMBER: _____	A3.1 FRONT & SIDE ELEVATIONS
ARCHITECTURAL SERVICES:	A3.2 REAR & SIDE ELEVATIONS
<ul style="list-style-type: none"> Missing or Conflicting Dimensions Plan Legibility Missing Options 	A4.1 STAIR SECTIONS
Mon-Fri: 8am - 5pm CHARLOTTE MKTS: 704-681-2032 ALL OTHER MKTS: 704-993-1861 E-mail: CADISSUE@truhomesusa.com	E1.1 FIRST FLOOR ELECTRICAL PLAN
ESTIMATING:	E1.2 SECOND FLOOR ELECTRICAL PLAN
<ul style="list-style-type: none"> Missing Material or Shortage Purchase Order Questions 	S1 FOUNDATION PLAN
Mon-Fri: 8am - 5pm ALL MKTS: 704-681-2032	S2.1 FIRST FLOOR FRAMING
	S3.1 ROOF FRAMING PLAN
	GN GENERAL STRUCTURAL NOTES
	ST-1 STEEL BEAM DETAILS
	D1 TYP. FOUNDATION DETAILS
	D3 TYP FLASHING DETAIL
	D4 TYP. PORTAL FRAME DETAIL - PPH
	D5 TYP FIREPLACE DETAILS
	D5.1 TYP STAIR DETAILS
	D5.2 TYP STAIR DETAILS
	D5.3 TYP STAIR DETAILS
	D9 TYP CORNICE DETAILS
	D10 TRIM DETAILS

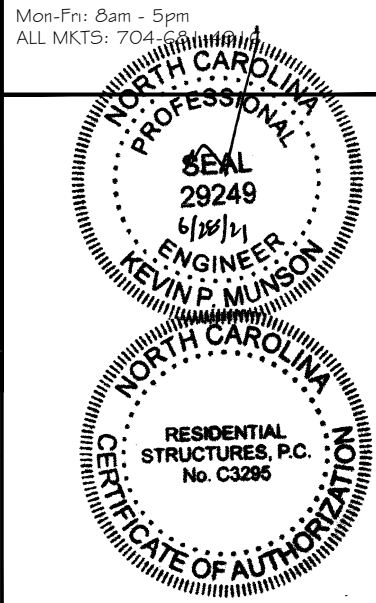

RESIDENTIAL STRUCTURES, P.C.
3410 N. Davidson St.
Charlotte, N.C. 28203
Seal For Structural Only

UPGRADED ELEVATION ORIGINAL CONTRACT ID#: XXXXX

WALKER GROVE
LOT# 13

JASPER
2304
HARNETT

Copyright True Homes L.L.C. All rights reserved. The duplication, reproduction, copying, sale, rental, licensing, or any other distribution or use of these drawings, any portion thereof, or the plans depicted herein is strictly prohibited.

PREPARED BY:
SARAH

DATE:
6-23-21

SCALE:
NOT TO SCALE

REVIEWED BY:
PETER

SHEET:
CS

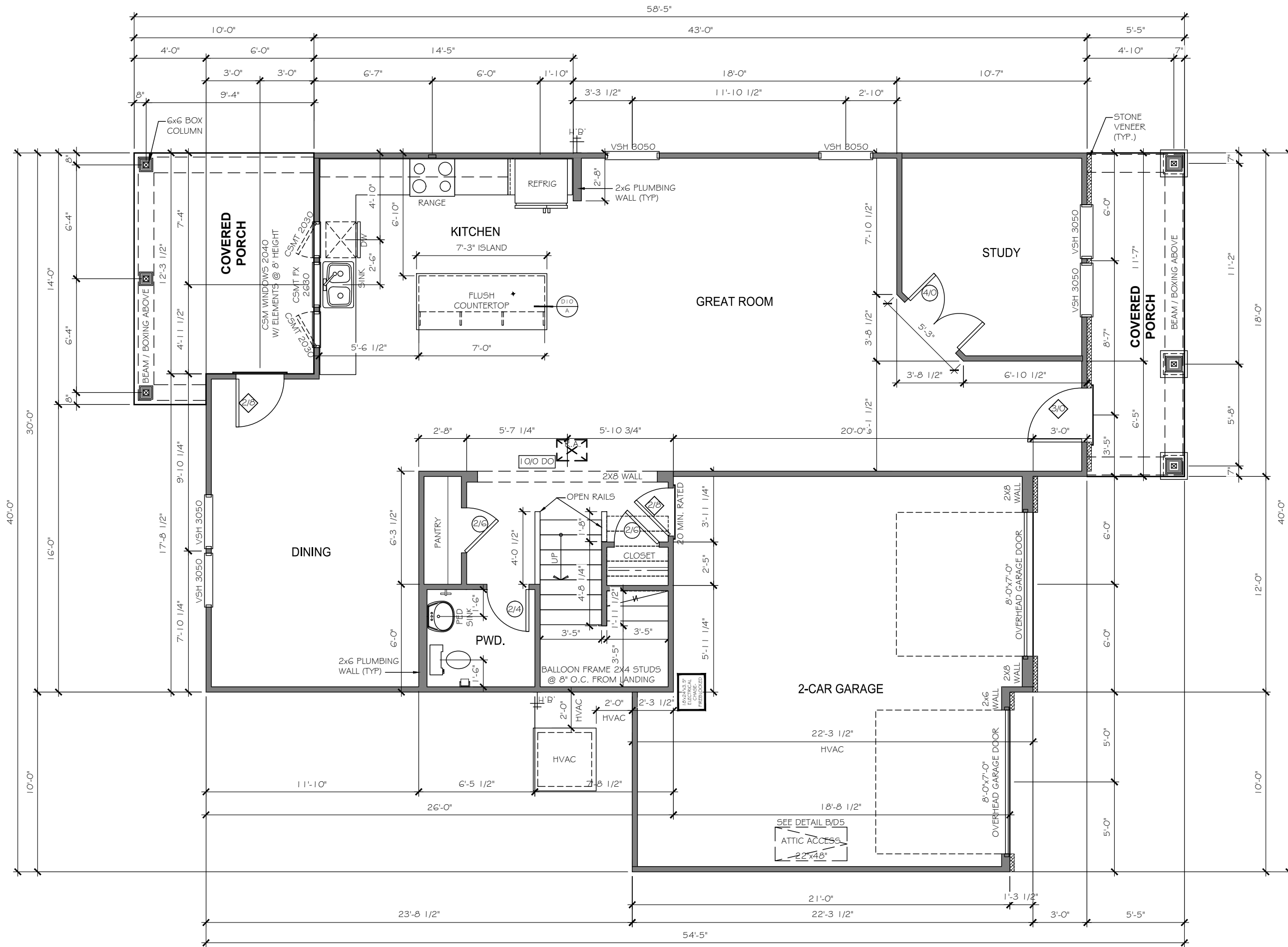

2304 - FIRST FLOOR PLAN

TrueHomes
 IT'S ALL ABOUT U
 2649 Breckridge Centre Dr.
 Suite 104
 Monroe, N.C. 28110
 704-271-1191

WALKER GROVE
 LOT# 13

JASPER
 2304

HARNETT

Copyright True Homes L.L.C. All rights reserved. The duplication, reproduction, copying, sale, rental, licensing, or any other distribution or use of these drawings, any portion thereof, or the plans depicted hereon is strictly prohibited.
 PREPARED BY:
 SARAH
 DATE:
 6-23-21
 SCALE:
 3/16" = 1'-0"
 REVIEWED BY:
 PETER

SHEET:
 A2.1

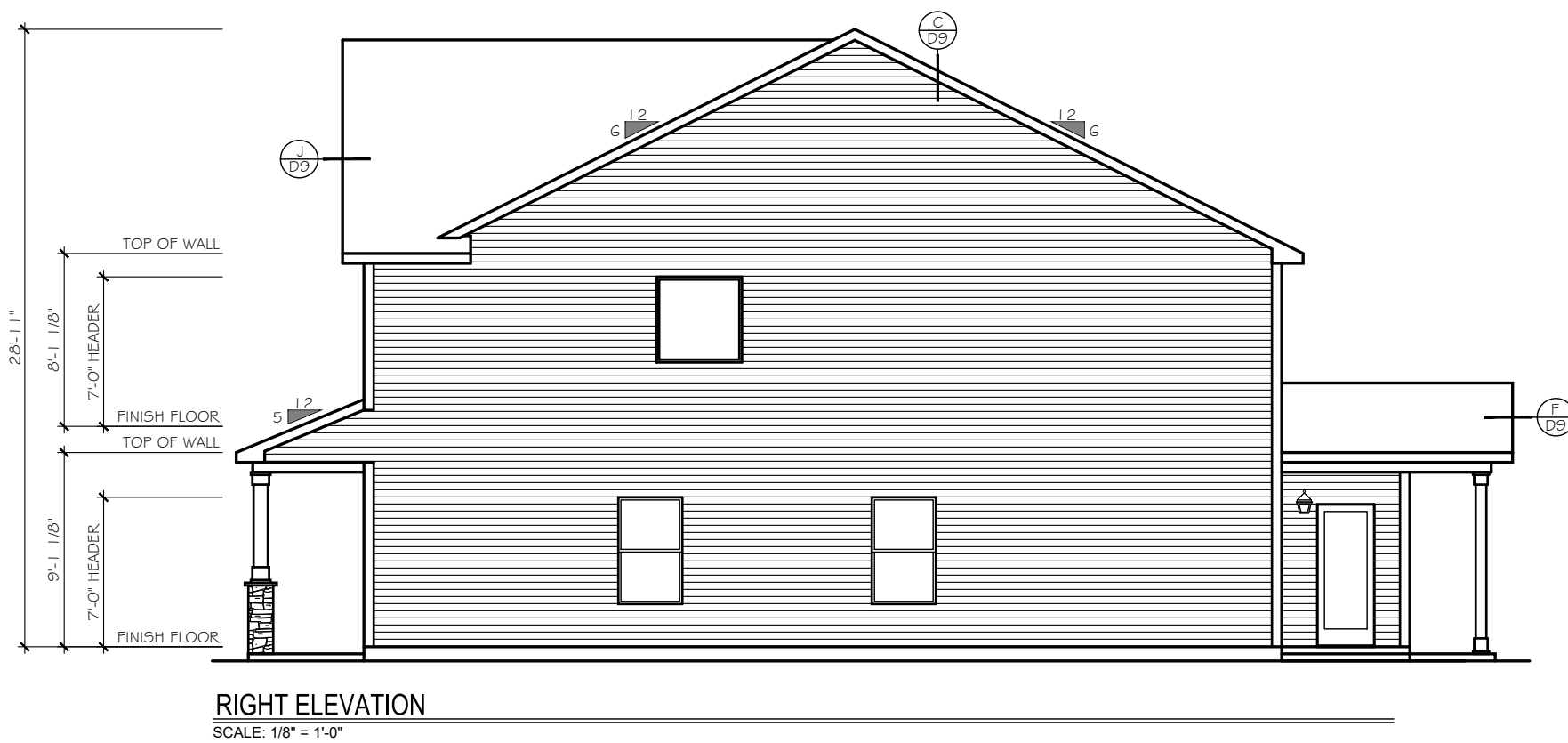
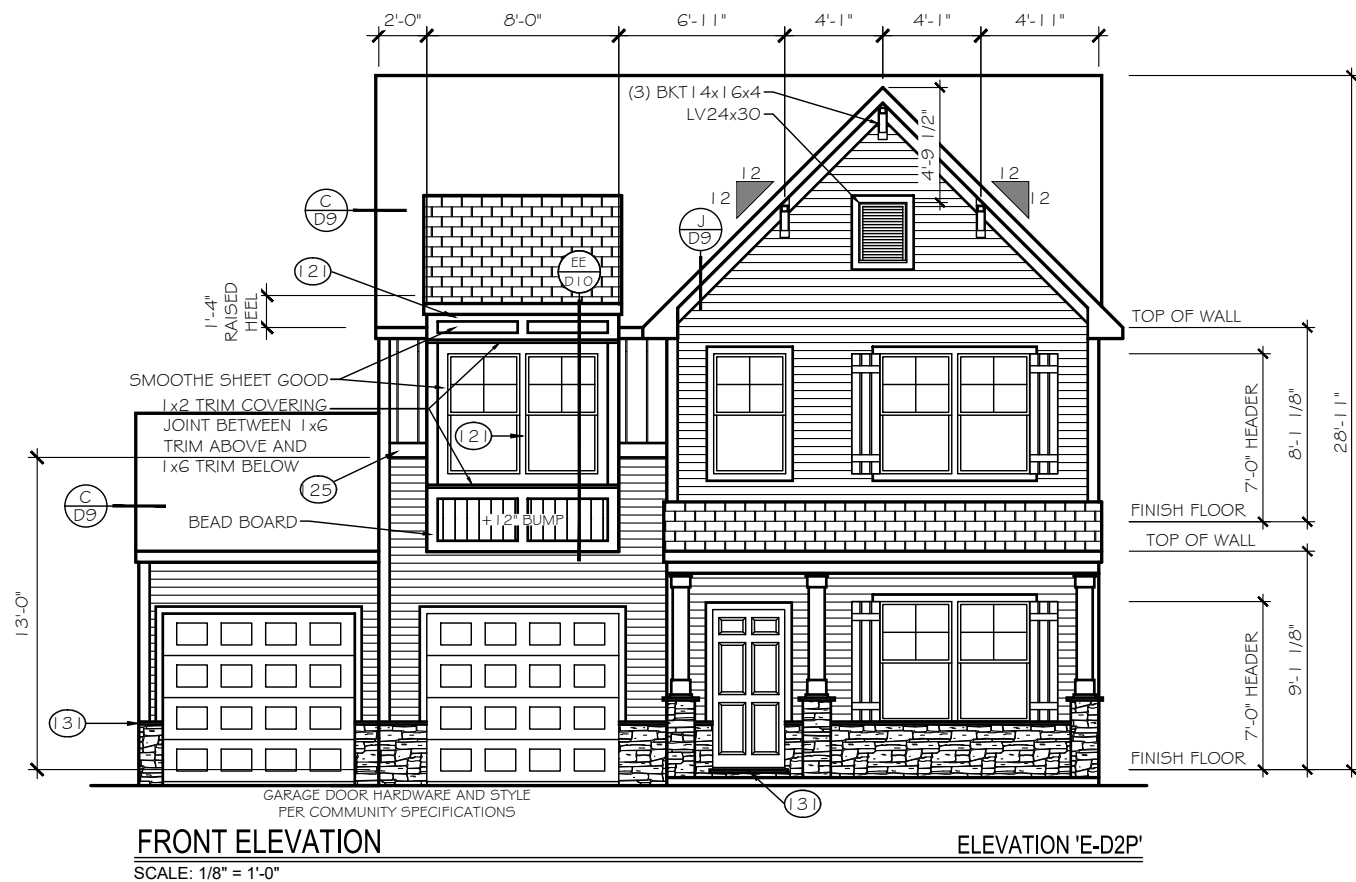

EXTERIOR MATERIAL LEGEND			
	B-N-B SIDING		STONE
	SHAKE SIDING		METAL ROOF
	HORIZONTAL SIDING		ROOF SHINGLE
	BRICK		SCALLOP SIDING

KEY NOTES	
(15)	FLASHING
(17)	VINYL SHUTTER
(20)	BRICKMOLD TRIM
(21)	1x4 TRIM BOARD
(23)	1x6 TRIM BOARD
(25)	1x8 TRIM BOARD
(28)	1x10 FRIEZE BOARD
(3)	1-1/2" THICK STONE CAP
(35)	ROWLOCK SILL
(37)	BRICK JACK ARCH
(39)	SOLDIER COURSE
(41)	PRECAST KEYSTONE
FOUNDATION REVEAL MAY VARY BASED ON SITE CONDITIONS, FINAL GRADING, & COMMUNITY SPECS.	
1x4 TRIM WHERE SHOWN AT WINDOWS AND DOORS UNLESS OTHERWISE NOTED	
SEE ROOF FRAMING PLANS FOR OVERHANG DIMENSIONS AND DORMER LOCATIONS	

TrueHomes
IT'S ALL ABOUT U
2649 Breckridge Centre Dr.
Suite 104
Monroe, N.C. 28110
704-271-1191

WALKER GROVE
LOT# 13

JASPER
2304

HARNETT

Copyright True Homes L.L.C. All rights reserved. The duplication, reproduction, copying, sale, rental, licensing, or any other distribution or use of these drawings, any portion thereof, or the plans depicted hereon is strictly prohibited.
PREPARED BY:
SARAH
DATE:
6-23-21
SCALE:
1/8" = 1'-0"
REVIEWED BY:
PETER

SHEET:
A3.1

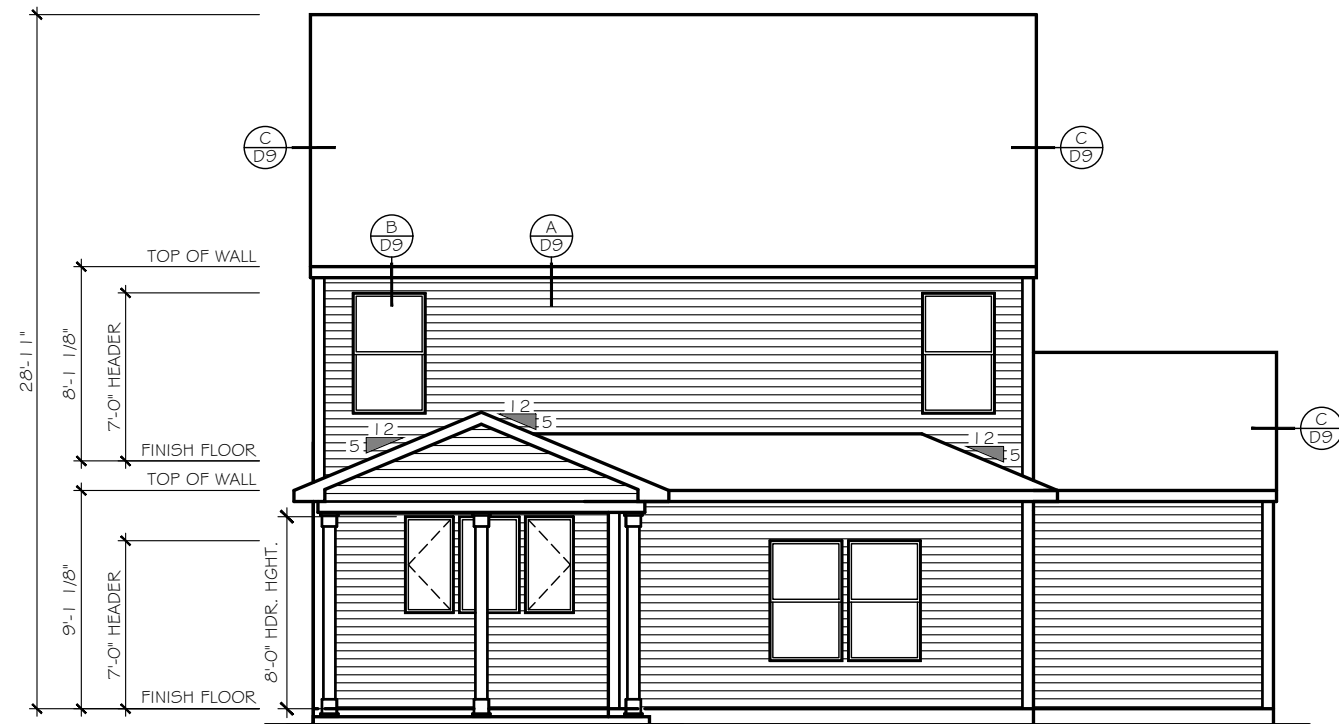

REAR ELEVATION - 2304
SCALE: 1/8" = 1'-0"

EXTERIOR MATERIAL LEGEND			
	B-N-B SIDING		STONE
	SHAKE SIDING		METAL ROOF
	HORIZONTAL SIDING		ROOF SHINGLE
	BRICK		SCALLOP SIDING

- FOUNDATION REVEAL MAY VARY BASED ON SITE CONDITIONS, FINAL GRADING, & COMMUNITY SPECS.
- KEY NOTES**
- (15) FLASHING
 - (17) VINYL SHUTTER
 - (20) BRICKMOLD TRIM
 - (21) 1X4 TRIM BOARD
 - (23) 1X6 TRIM BOARD
 - (25) 1X8 TRIM BOARD
 - (26) 1X10 FRIEZE BOARD
 - (31) 1 - 1/2" THICK STONE CAP
 - (35) ROWLOCK SILL
 - (37) BRICK JACK ARCH
 - (39) SOLDIER COURSE
 - (41) PRECAST KEYSTONE
- 1x4 TRIM WHERE SHOWN AT WINDOWS AND DOORS UNLESS OTHERWISE NOTED
- SEE ROOF FRAMING PLANS FOR OVERHANG DIMENSIONS AND DORMER LOCATIONS

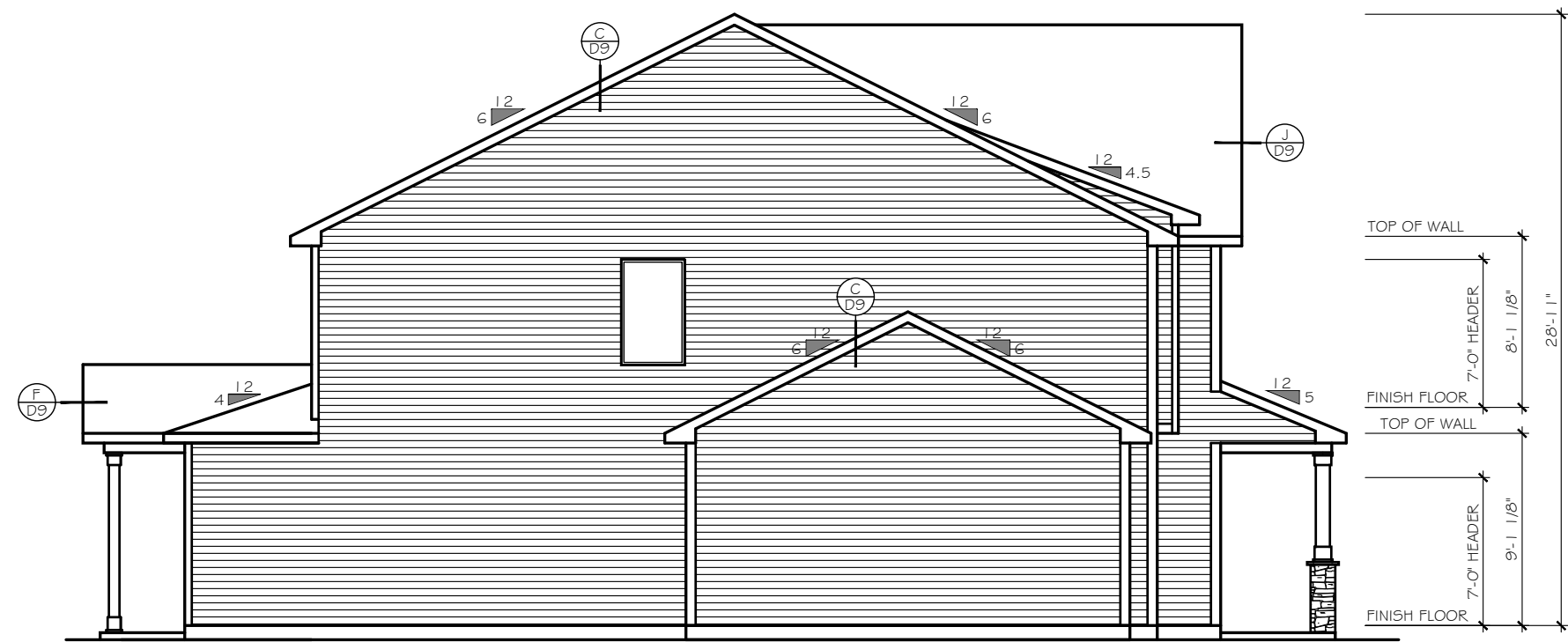

LEFT ELEVATION - 2304
SCALE: 1/8" = 1'-0"

TrueHomes
IT'S ALL ABOUT U
2649 Breckridge Centre Dr.
Suite 104
Monroe, N.C. 28110
704-271-1191

WALKER GROVE
LOT# 13

JASPER
2304

HARNETT

Copyright True Homes L.L.C. All rights reserved. The duplication, reproduction, copying, sale, rental, licensing, or any other distribution or use of these drawings, any portion thereof, or the plans depicted hereon is strictly prohibited.

PREPARED BY:
SARAH

DATE:
6-23-21

SCALE:
1/8" = 1'-0"

REVIEWED BY:
PETER

SHEET:
A3.2

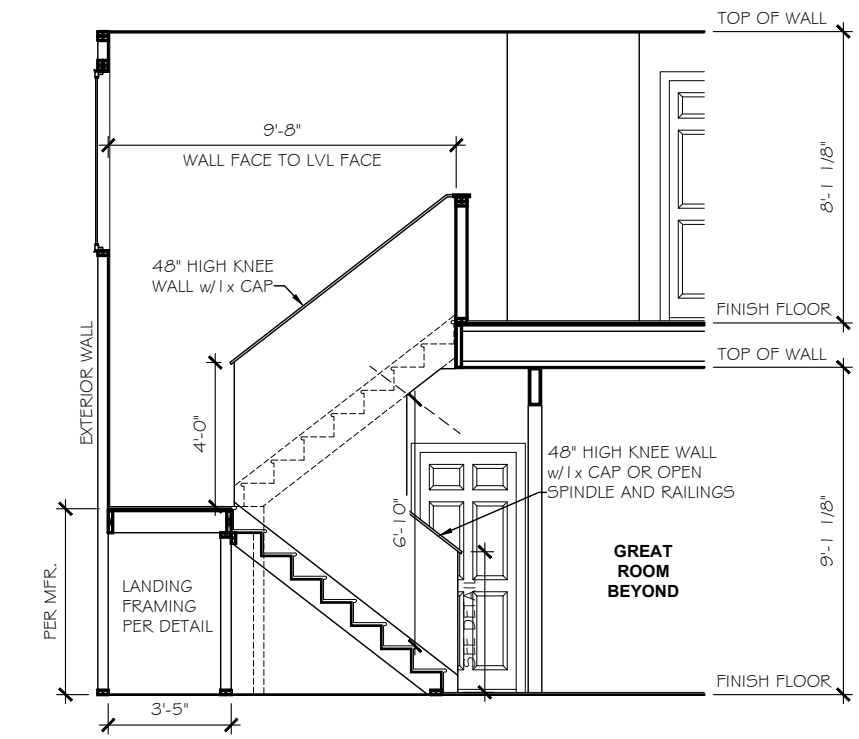

STAIR SECTION
 SCALE: 3/16" = 1'-0"

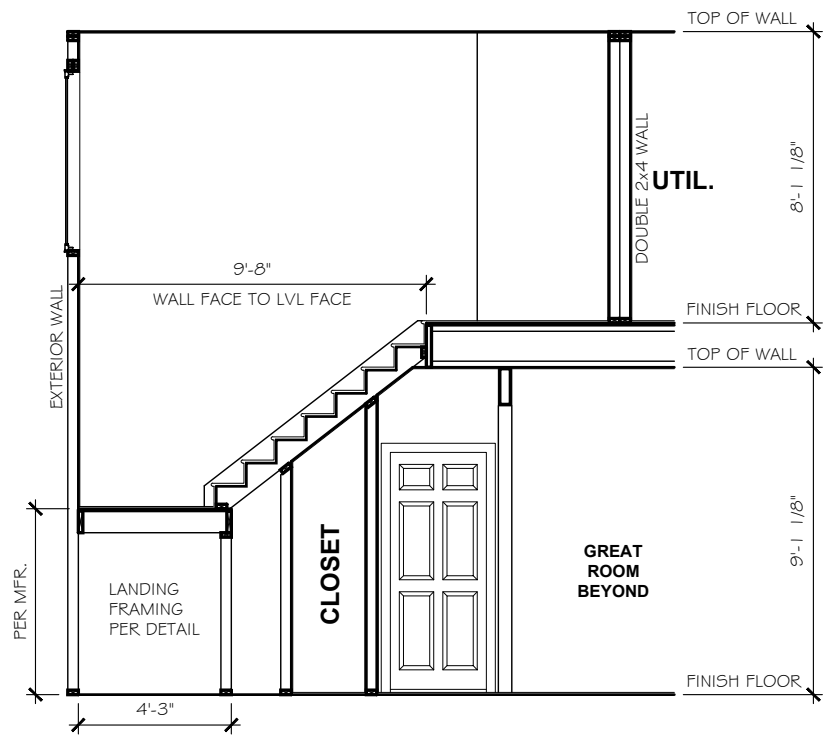

9" PLATE
 2300-2303 SECOND FLOOR

Copyright True Homes L.L.C. All rights reserved. The duplication, reproduction, copying, sale, rental, licensing, or any other distribution or use of these drawings, any portion thereof, or the plans depicted hereon is strictly prohibited.

PREPARED BY:
 SARAH
 DATE:
 6-23-21
 SCALE:
 AS SHOWN
 REVIEWED BY:
 PETER

SHEET:
A4.1

ELECTRICAL LEGEND	
*	INDICATES ADDITIONAL OUTLET PER CLIENT
(D)	OUTLET 110V (D=DEDICATED CIRCUIT)
5' AFF	RECESSED OUTLET 110V
(D)	OUTLET 220V (D=DEDICATED CIRCUIT)
WP	OUTLET 110V WATER PROOF
GFI	OUTLET 110V GFI (D=DEDICATED CIRCUIT)
(D)	FLOOR OUTLET 110V
(D)	SWITCHED OUTLET
USB	DUAL USB OUTLET (3.1 AMP)
77" AFF	EXT. RECESSED OUTLET # TV w/ COVER
TV	TV WALL JACK
(D)	PHONE / DATA JACK
(T)	THERMOSTAT
(S)	SMOKE / CO DETECTOR
(S)	SMOKE DETECTOR
(S)	SWITCH
(S)	3-WAY SWITCH
(S)	4-WAY SWITCH
(D)	DIMMER SWITCH
(P)	PUSH BUTTON
(L)	WALL MOUNT LIGHT FIXTURE
(L)	CEILING LIGHT
(L)	HANGING LIGHT
(J)	JUNCTION BOX / PREWIRE
(R)	RECESSED CAN LIGHT
(L)	LED CAN LIGHT
(V)	VAPOR PROOF CAN LIGHT
(L)	MINI-CAN LIGHT
(L)	UNDER CABINET LIGHT
(S)	WALL SCONCE (STD 72" AFF UNO)
(L)	FLOOD LIGHT - LOCATION TO BE VERIFIED IN FIELD WITH BUILDER/CLIENT
(L)	PENDANT LIGHT (6'-7" AFF STD)
(F)	EXHAUST FAN
(F)	EXHAUST FAN / LIGHT
(K)	KEYLESS ENTRY
(F)	CEILING FAN PRE-WIRE OR FIXTURE AS NOTED
(E)	ELECTRIC PANEL (METER LOCATION MAY VARY)
(D)	DISCONNECT BOX
(H)	DED. HOT TUB CIRCUIT (50amp, 240v GFI)
(E)	EV CHARGING OUTLET (30amp, 220v GFI)

LOW VOLTAGE LEGEND	
TEC CAN	
(W)	36" WHIP IN WALL (NO OUTLET)
HD LINK	
5' AFF HD-L	
(C)	CHASE PIPE
(C)	HDMI CABLE
(C)	2 CAT5E DATA
(C)	TV/DATA JACK
(C)	110v OUTLET (RECESSED AFF)
(C)	110v OUTLET (STANDARD)
CHASE PIPE	
5' AFF CH-P	
(C)	CHASE PIPE WALL PLATES (OUTLET SEPARATE)
(S)	SPEAKER
(PWS)	PRE-WIRE FOR SPEAKER
(W)	WALL PLATE CONTROL
CHECK SELECTIONS FOR COMPLETE LOW VOLTAGE LAYOUT.	
LOW VOLTAGE TRADE RESPONSIBLE FOR LOCATING AND INSTALLING ALL SELECTED PRODUCTS.	

ELECTRICAL QUANTITIES		
Count	Name	Visibility
1	Lights	Exhaust Fan
1	Lights	Can Light VP
2	switch	Push Button
2	Lights	Hanging Light
2	Jacks	Thermostat
2	Lights	Flood Light
2	Jacks	TV Jack
2	Jacks	Phone Jack
3	Detectors	Smoke/Carbon Monoxide Detector
3	Lights	Pendant Light
3	Receptacle	WP
3	Lights	Exhaust Fan/Light
4	Detectors	Smoke Detector
4	Ceiling Fan 1.1	w/ Flush Mount Std.
5	Lights	LED Ceiling Light
7	Lights	Carnage Light
8	Lights	Can Light
12	Lights	Ceiling Light
15	Receptacle	GFI
15	switch	3-Way Switch
31	switch	Single Pole Switch
41	Receptacle	110V

CHECK SELECTIONS FOR CPI LAYOUT. ALL TV, PHONE, CABLE, AUDIO, AND SECURITY SYSTEM OUTLETS WILL BE LOCATED PER CPI LAYOUT, REGARDLESS OF WHETHER TV AND PHONE ARE SHOWN.

ELECTRICAL TO BE PLACED PER CODE IN THE FIELD. SEE QUALITY STANDARDS FOR HEIGHTS
PLACE GAS METER MAX 15' AWAY FROM ELECTRICAL METER IF APPLICABLE

ELEC. NOTICE
ROOMS WITH WAINSCOT PER SELECTIONS REQUIRE OUTLETS TO BE PLACED 1'-0" FROM CORNER OR CENTERED ON WALL AT STANDARD HEIGHT (U.N.O.).
EXCLUDES HALLWAYS

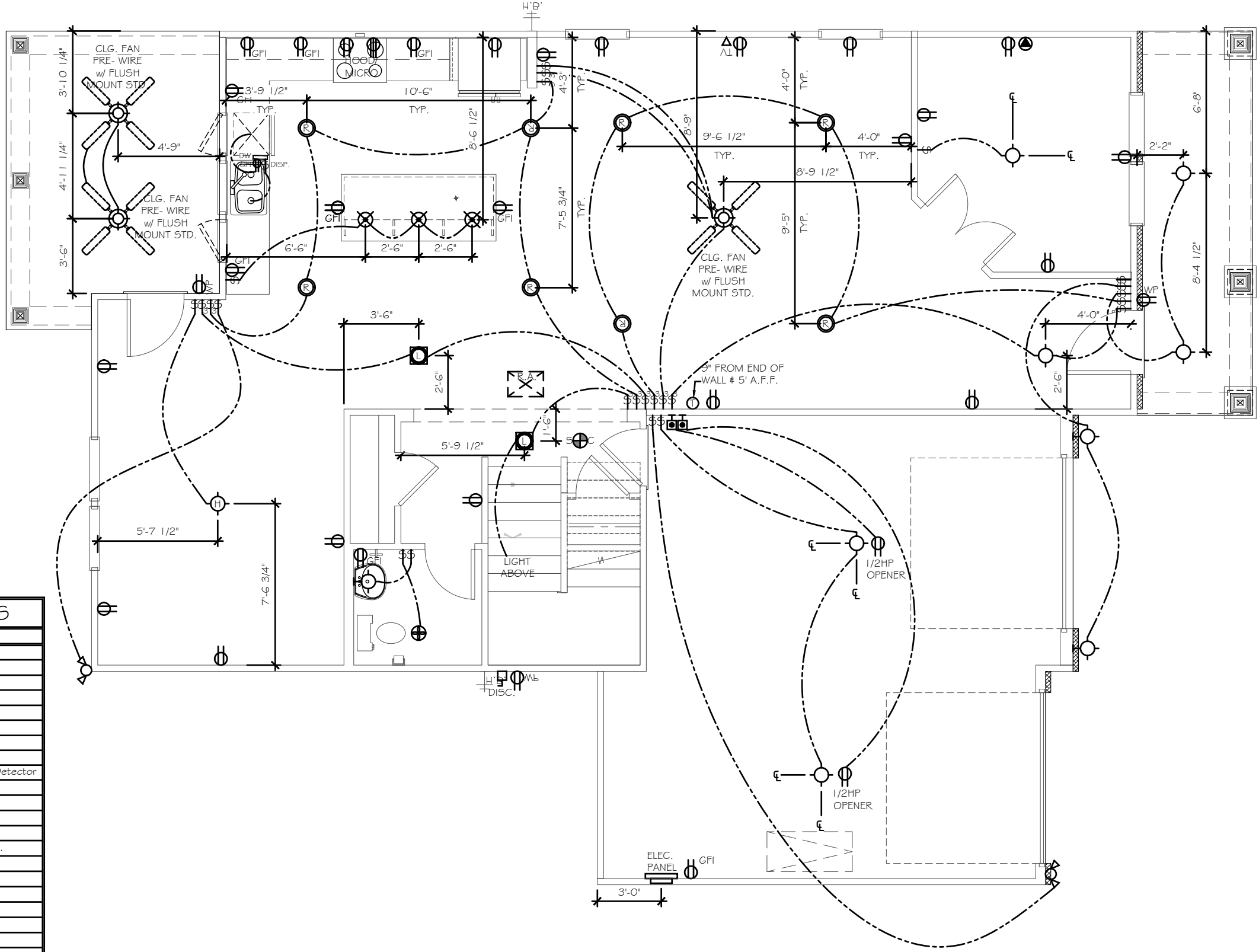

TrueHomes
IT'S ALL ABOUT U
2649 Breckridge Centre Dr.
Suite 104
Monroe, N.C. 28110
704-271-1191

WALKER GROVE
LOT# 13

JASPER
2304
HARNETT

Copyright True Homes L.L.C. All rights reserved. The duplication, reproduction, copying, sale, rental, licensing, or any other distribution or use of these drawings, any portion thereof, or the plans depicted herein is strictly prohibited.
PREPARED BY:
SARAH
DATE:
6-23-21
SCALE:
3/16"=1'-0"
REVIEWED BY:
PETER

SHEET:
E1.1

2304 - FIRST FLOOR PLAN

ELECTRICAL LEGEND	
*	INDICATES ADDITIONAL OUTLET PER CLIENT
Ⓞ	OUTLET 110V (D=DEDICATED CIRCUIT)
5' AFF	RECESSED OUTLET 110V
Ⓞ	OUTLET 220V (D=DEDICATED CIRCUIT)
Ⓞ	OUTLET 110V WATER PROOF
GFI	OUTLET 110V GFI (D=DEDICATED CIRCUIT)
Ⓞ	FLOOR OUTLET 110V
Ⓞ	SWITCHED OUTLET
USB	DUAL USB OUTLET (3.1 AMP)
77" AFF	EXT. RECESSED OUTLET & TV w/ COVER
TV	TV WALL JACK
Ⓞ	PHONE / DATA JACK
Ⓞ	THERMOSTAT
S	SMOKE / CO DETECTOR
S	SMOKE DETECTOR
Ⓞ	SWITCH
Ⓞ	3-WAY SWITCH
Ⓞ	4-WAY SWITCH
Ⓞ	DIMMER SWITCH
Ⓞ	PUSH BUTTON
Ⓞ	WALL MOUNT LIGHT FIXTURE
Ⓞ	CEILING LIGHT
Ⓞ	HANGING LIGHT
J	JUNCTION BOX / PREWIRE
Ⓞ	RECESSED CAN LIGHT
Ⓞ	LED CAN LIGHT
Ⓞ	VAPOR PROOF CAN LIGHT
Ⓞ	MINI-CAN LIGHT
I	UNDER CABINET LIGHT
Ⓞ	WALL SCONCE (STD 72" AFF UNO)
Ⓞ	FLOOD LIGHT - LOCATION TO BE VERIFIED IN FIELD WITH BUILDER/CLIENT
Ⓞ	PENDANT LIGHT (6'-7" AFF STD)
Ⓞ	EXHAUST FAN
Ⓞ	EXHAUST FAN / LIGHT
Ⓞ	KEYLESS ENTRY
Ⓞ	CEILING FAN PRE-WIRE OR FIXTURE AS NOTED
Ⓞ	ELECTRIC PANEL (METER LOCATION MAY VARY)
DISC.	DISCONNECT BOX
HTC	DED. HOT TUB CIRCUIT (50amp, 240v GFI)
Ⓞ	EV CHARGING OUTLET (30amp, 220v GFI)

LOW VOLTAGE LEGEND	
TEC CAN	
Ⓞ	36" WHIP IN WALL
Ⓞ	(NO OUTLET)
HD LINK	
5' AFF	HD-L
•	CHASE PIPE
•	HDMI CABLE
•	2 CAT5E DATA
•	TV/DATA JACK
•	110v OUTLET (RECESSED AFF)
•	110v OUTLET (STANDARD)
CHASE PIPE	
5' AFF	CH-F
•	CHASE PIPE WALL PLATES (OUTLET SEPARATE)
S	SPEAKER
PWS	PRE-WIRE FOR SPEAKER
●	WALL PLATE CONTROL
CHECK SELECTIONS FOR COMPLETE LOW VOLTAGE LAYOUT.	
LOW VOLTAGE TRADE RESPONSIBLE FOR LOCATING AND INSTALLING ALL SELECTED PRODUCTS.	

CHECK SELECTIONS FOR CFI LAYOUT. ALL TV, PHONE, CABLE, AUDIO, AND SECURITY SYSTEM OUTLETS WILL BE LOCATED PER CFI LAYOUT, REGARDLESS OF WHETHER TV AND PHONE ARE SHOWN.

ELECTRICAL TO BE PLACED PER CODE IN THE FIELD. SEE QUALITY STANDARDS FOR HEIGHTS
PLACE GAS METER MAX 15' AWAY FROM ELECTRICAL METER IF APPLICABLE

ELEC. NOTICE
ROOMS WITH WAINSCOT PER SELECTIONS REQUIRE OUTLETS TO BE PLACED 1'-0" FROM CORNER OR CENTERED ON WALL AT STANDARD HEIGHT (U.N.O.).
EXCLUDES HALLWAYS

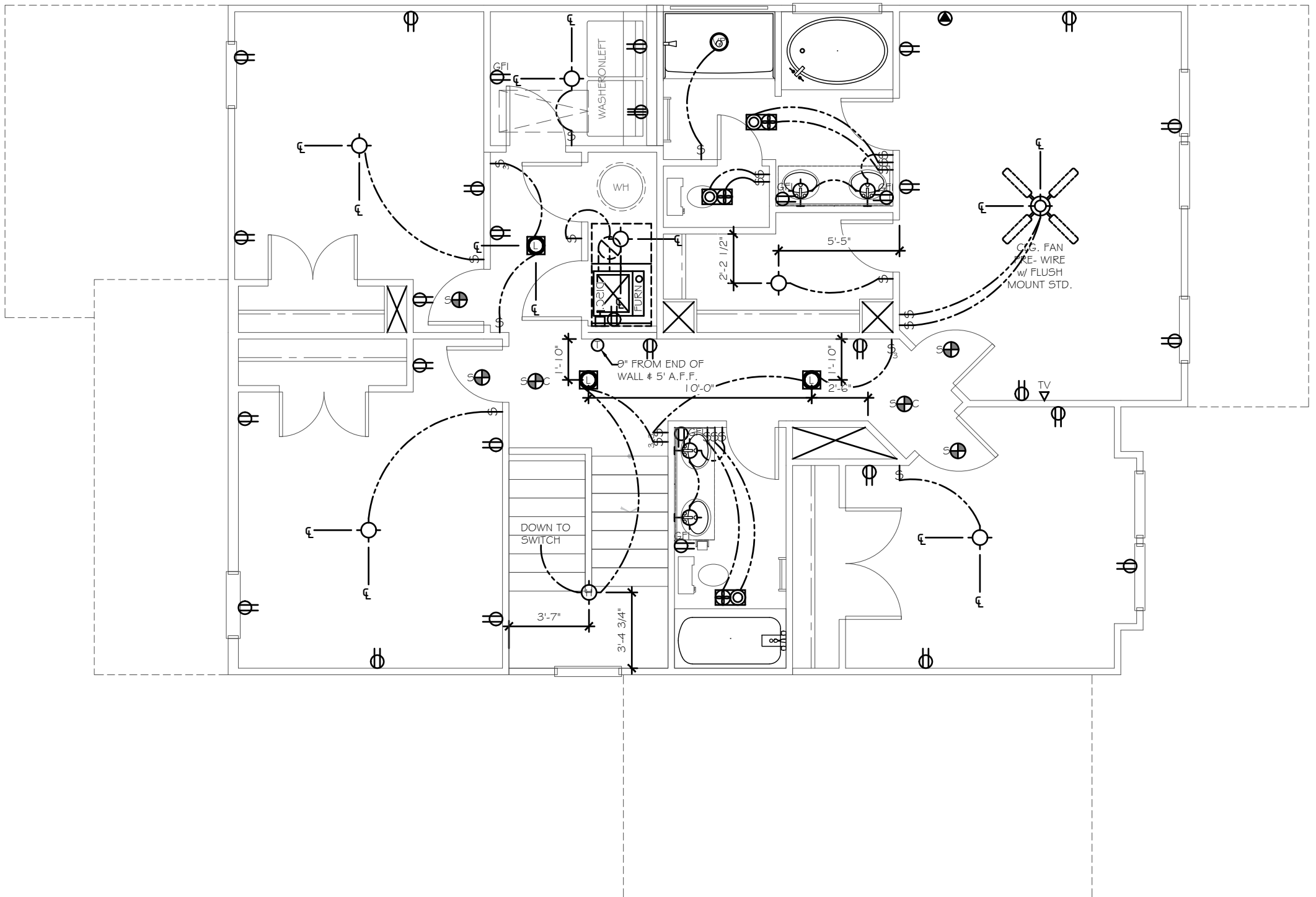

2304 - SECOND FLOOR PLAN

TrueHomes
IT'S ALL ABOUT U
2649 Breckridge Centre Dr.
Suite 104
Monroe, N.C. 28110
704-271-1191

WALKER GROVE
LOT# 13

JASPER
2304

HARNETT

Copyright True Homes L.L.C. All rights reserved. The duplication, reproduction, copying, sale, rental, licensing, or any other distribution or use of these drawings, any portion thereof, or the plans depicted hereon is strictly prohibited.
PREPARED BY:
SARAH
DATE:
6-23-21
SCALE:
3/16"=1'-0"
REVIEWED BY:
PETER

SHEET:
E1.2

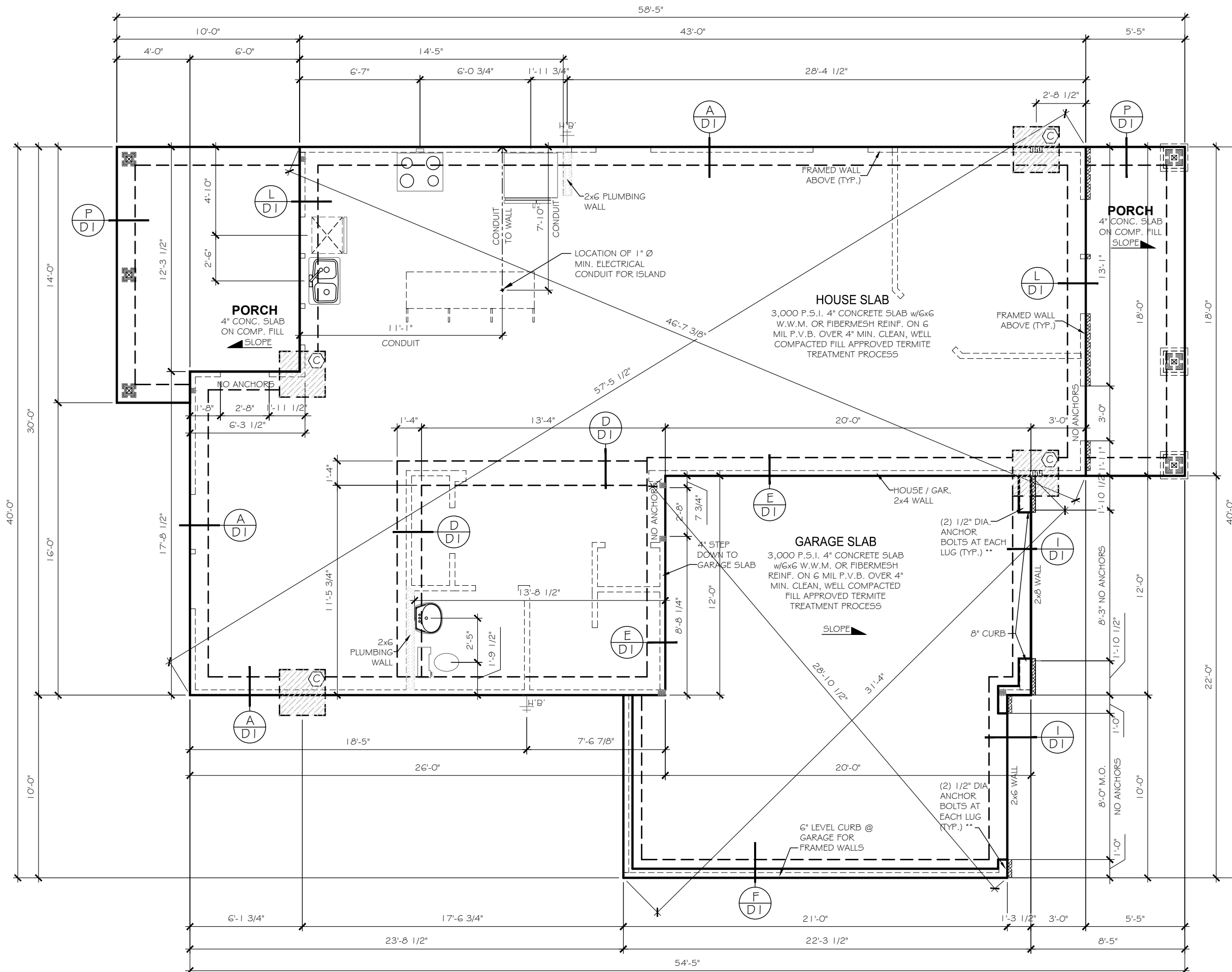

PAD FOOTING SIZES	
KEYNOTE	SIZE
A	18"x18"x8" w/3-#4's E.W.
B	24"x24"x12" w/4-#4's E.W.
C	30"x30"x12" w/4-#4's E.W.
D	36"x36"x12" w/4-#4's E.W.
E	48"x48"x12" w/6-#4's E.W.
F	36"x60"x12" w/#4's @ 6" O.C. E.W.

LENGTH x WIDTH x DEPTH [REBAR REQ'D]
DEPTH TO INCLUDE SLAB THICKNESS

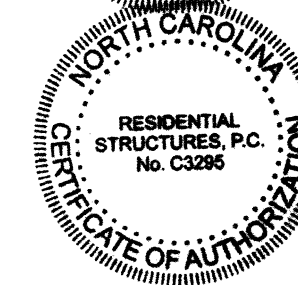

RESIDENTIAL STRUCTURES, P.C.
3410 N. Davidson St.
Charlotte, N.C. 28205
Seal For Structural Only

TrueHomes
IT'S ALL ABOUT U
2649 Breckridge Centre Dr.
Suite 104
Monroe, N.C. 28110
704-271-1191

WALKER GROVE
LOT# 13

JASPER
2304
HARNETT

Copyright True Homes L.L.C. All rights reserved. The duplication, reproduction, copying, sale, rental, licensing, or any other distribution or use of these drawings, any portion thereof, or the plans depicted hereon is strictly prohibited.
PREPARED BY:
SARAH
DATE:
6-23-21
SCALE:
3/16"=1'-0"
REVIEWED BY:
PETER

SHEET:
S1

2304 - MONO FOUNDATION PLAN

****SEE COVER PAGE FOR**
ROUGH OPENING DIMENSIONS**

KING / JACK STUD SCHEDULE		POST SCHEDULE	
		2x4 STUDS	2x6 STUDS
△ (2) JACKS	△ (2) JACKS	△ (2) JACKS	△ (2) JACKS
△ (1) JACK # (1) KING	△ (1) JACK # (1) KING	△ (1) JACK # (1) KING	△ (1) JACK # (1) KING
△ (1) JACK # (2) KINGS	△ (1) JACK # (2) KINGS	△ (1) JACK # (2) KINGS	△ (1) JACK # (2) KINGS
△ (1) JACK # (3) KINGS	△ (1) JACK # (3) KINGS	△ (1) JACK # (3) KINGS	△ (1) JACK # (3) KINGS
△ (2) JACKS # (1) KING	△ (2) JACKS # (1) KING	△ (2) JACKS # (1) KING	△ (2) JACKS # (1) KING
△ (2) JACKS # (2) KINGS	△ (2) JACKS # (2) KINGS	△ (2) JACKS # (2) KINGS	△ (2) JACKS # (2) KINGS
△ (2) JACKS # (3) KINGS	△ (2) JACKS # (3) KINGS	△ (2) JACKS # (3) KINGS	△ (2) JACKS # (3) KINGS
△ (3) JACKS # (3) KINGS	△ (3) JACKS # (3) KINGS	△ (3) JACKS # (3) KINGS	△ (3) JACKS # (3) KINGS
△ (4) JACKS # (4) KINGS	△ (4) JACKS # (4) KINGS	△ (4) JACKS # (4) KINGS	△ (4) JACKS # (4) KINGS
		EX: (2) 2X4	EX: (2) 2X6
		NUMBER INSIDE CALLOUT INDICATES TOTAL NUMBER OF STUDS.	
		4X4 POST	6X6 POST
		LETTER 'P' INSIDE CALLOUT INDICATES A SOLID 4x4 or 6x6 POST	

CODE REFERENCE PER STATE		
NORTH CAROLINA :2018 NCRC (TABLE R602.10.1)		
SOUTH CAROLINA :2018 IRC (TABLE R602.10.4)		
STRUCTURAL LEGEND		
	BEARING WALL	
	METHOD GB OF LOCAL CODE	
	BEARING WALL W/ METHOD GB OF LOCAL CODE	
	CENTER OF BEAM / JOIST / GIRDER TRUSS	
	METHOD CS-WSP (UNO)	
	INTERIOR SHEAR WALL PER HIGH WIND NOTE 1.C	
	USP LSTA24 HOLDDOWN OR EQ.	
	USP STAD I 4 HOLDDOWN OR EQ.	
	USP DTB-TZ HOLDDOWN OR EQ.	
	USP PHD8 HOLDDOWN OR EQ.	
	USP RS-150 COIL STRAP HOLDDOWN (36" LONG - 12" MIN. END LAP)	
WALL BRACING NOTE		
<ul style="list-style-type: none"> 115 MPH WIND ZONE - EXP. B 8, 9 OR 10 FT. WALL HEIGHT ENGINEERED WALL BRACING DESIGN MEETS OR EXCEEDS THE INTENT OF THE: 2018 NCRC - NORTH CAROLINA 2018 IRC - SOUTH CAROLINA 		
METHOD	MATERIAL	FASTENER SPACING
CS-WSP	MIN. 3/8" OSB	6" EDGES, 12" FIELD
GB	MIN. 1/2" GYP	7" EDGES, 7" FIELD
ALL WOOD STRUCTURAL PANEL BRACING SHALL BE ATTACHED TO FRAMING OR BLOCKING, EXCEPT GB BRACING. HORIZONTAL JOINTS SHALL NOT BE REQ'D TO BE BLOCKED WHEN JOINTS ARE FINISHED.		
ALTERNATE SILL PLATE ANCHORAGE ILO STRAPS 1/2" ANCHOR BOLTS @ 6'-0" O.C. w/ 7" EMBEDMENT INTO MASONRY or EQUIVALENT MECHANICAL FASTENER- MAX 12" FROM WALL CORNERS		
SEE TRUSS HEEL BLOCKING/SHEATHING REQUIREMENTS SHEET D3		

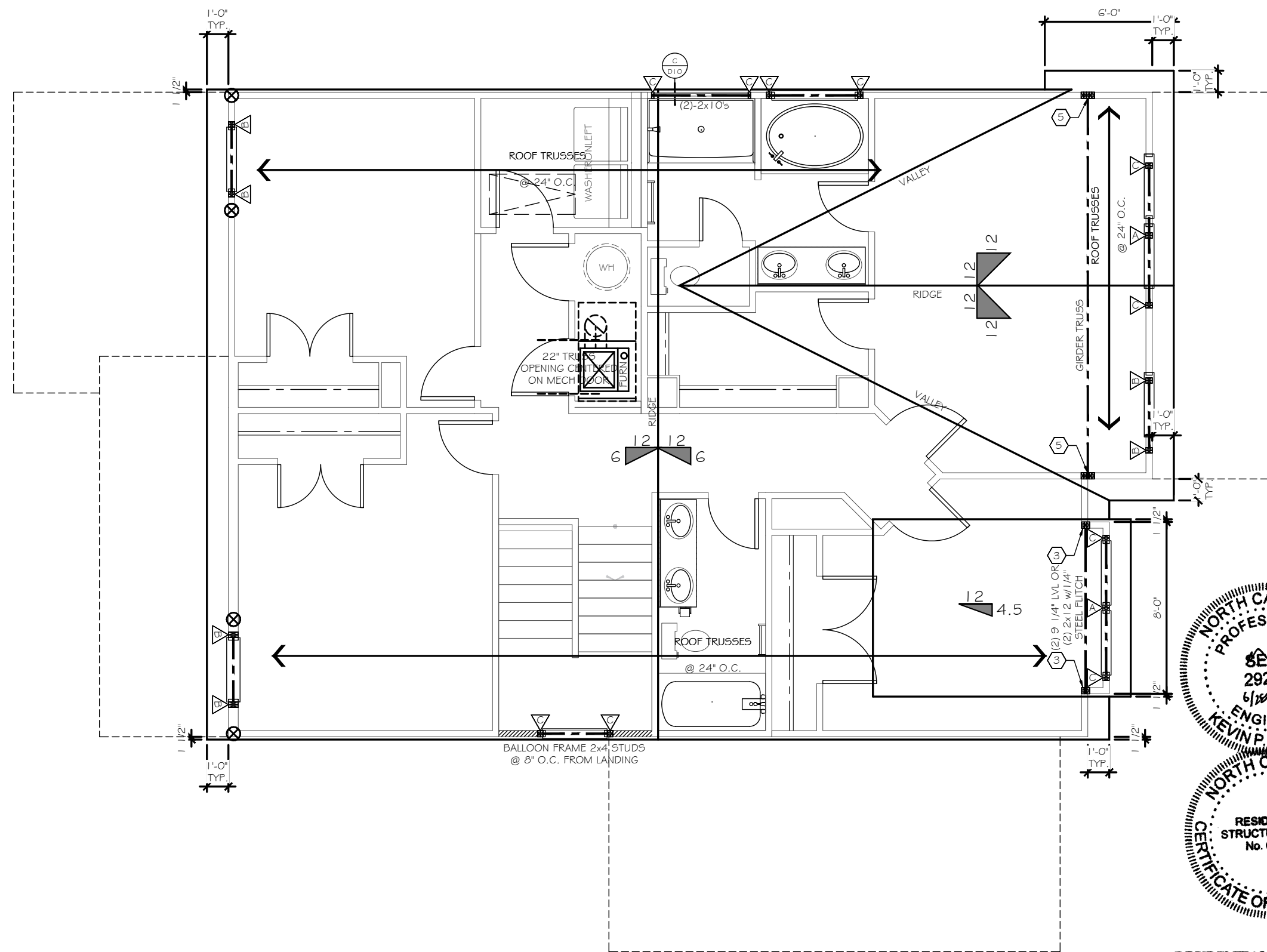

ROOF FRAMING PLAN

TrueHomes
IT'S ALL ABOUT U
2649 Breckridge Centre Dr.
Suite 104
Monroe, N.C. 28110
704-271-1191

WALKER GROVE
LOT# 13

JASPER
2304
HARNETT

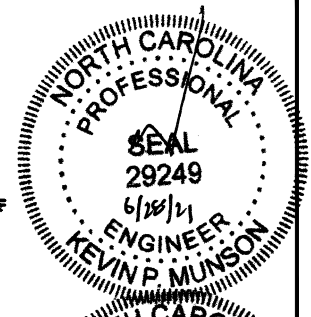

RESIDENTIAL STRUCTURES, P.C.
3410 N. Davidson St.
Charlotte, N.C. 28205
Seal For Structural Only

Copyright True Homes L.L.C. All rights reserved. The duplication, reproduction, copying, sale, rental, licensing, or any other distribution or use of these drawings, any portion thereof, or the plans depicted hereon is strictly prohibited.
PREPARED BY: SARAH
DATE: 6-23-21
SCALE: 3/16"=1'-0"
REVIEWED BY: PETER

SHEET:
S3.1

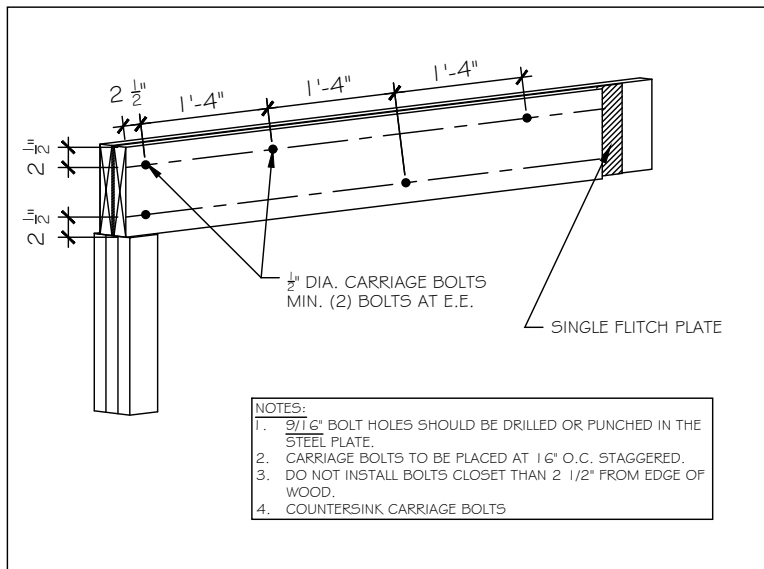

STL-1 SINGLE FLITCH BEAM

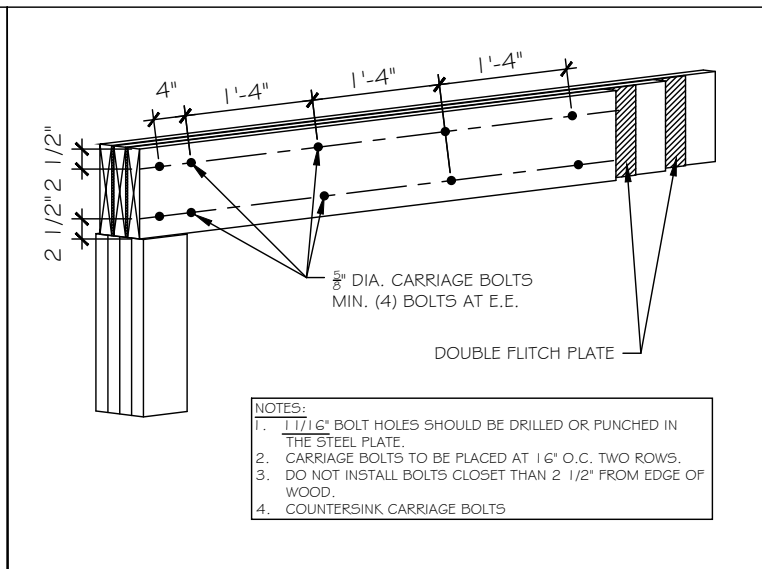

STL-2 DOUBLE FLITCH BEAM

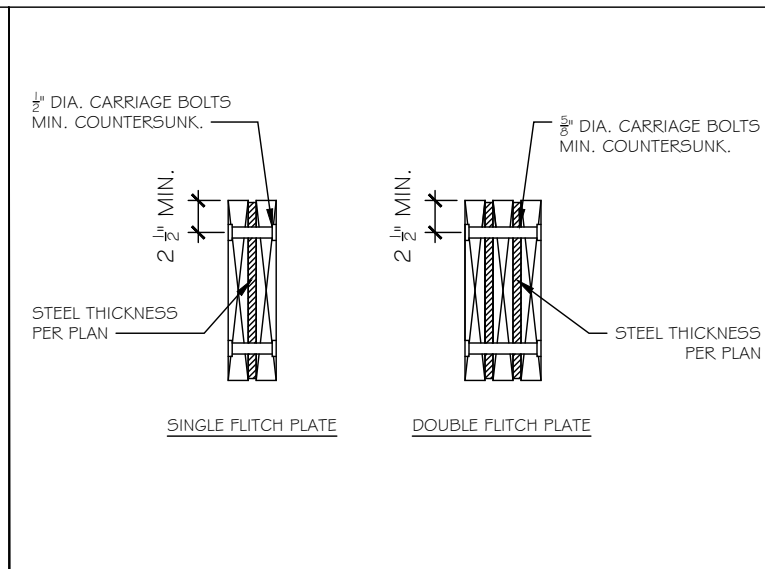

STL-3 FLITCH BEAM

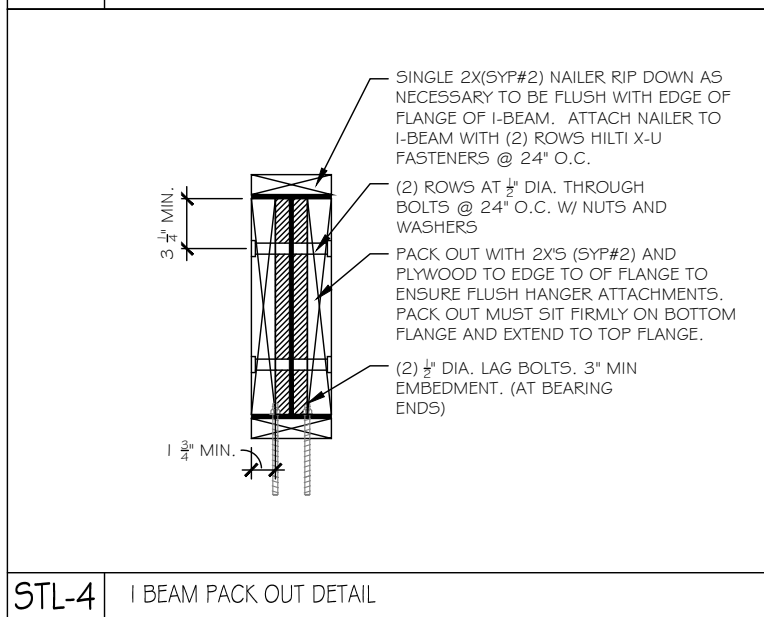

STL-4 I BEAM PACK OUT DETAIL

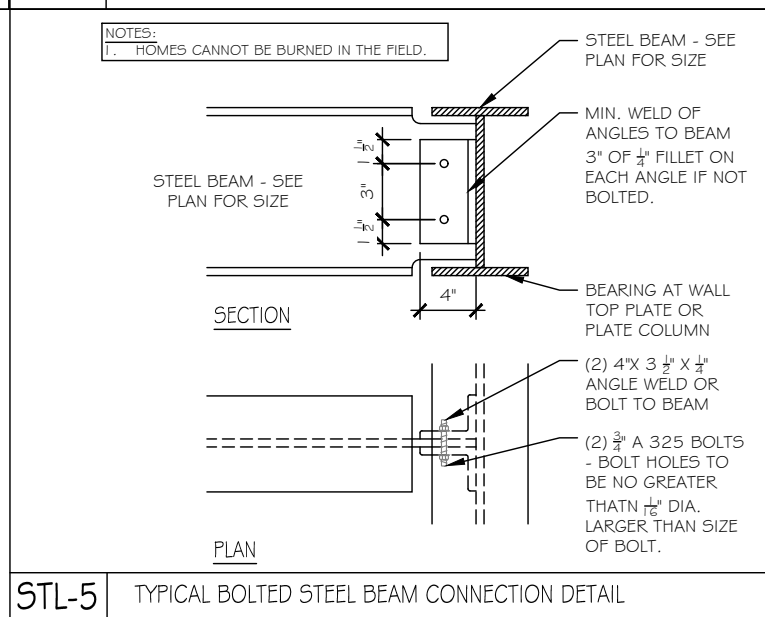
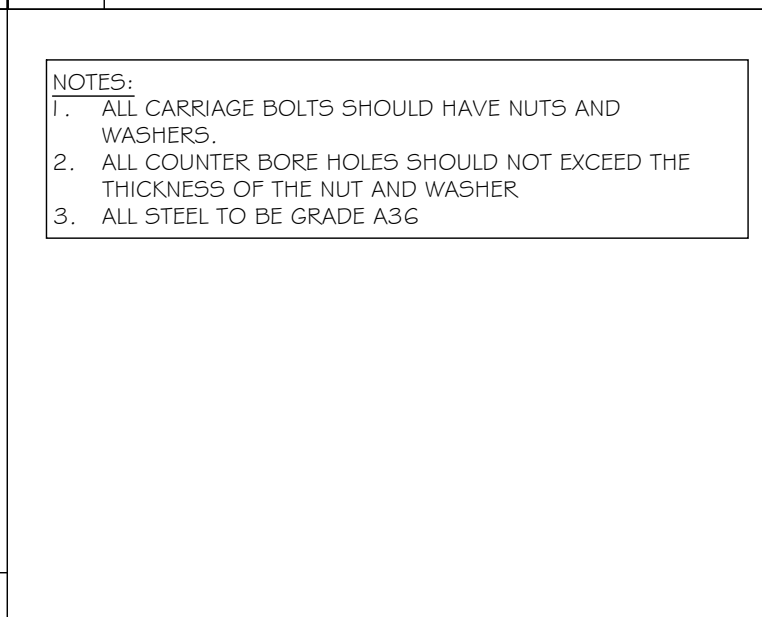

STL-5 TYPICAL BOLTED STEEL BEAM CONNECTION DETAIL

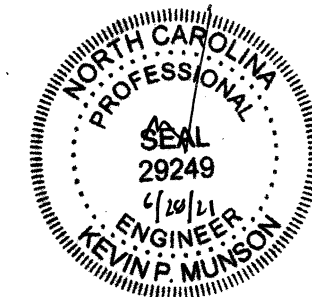

RESIDENTIAL STRUCTURES, P.C.
3410 N. Davidson St.
Charlotte, N.C. 28205
Seal For Structural Only

TrueHomes
IT'S ALL ABOUT U
2649 Breckridge Centre Dr.
Suite 104
Monroe, N.C. 28110
704-271-1191

WALKER GROVE
LOT# 13

JASPER
2304

HARNETT

Copyright True Homes L.L.C. All rights reserved. The duplication, reproduction, copying, sale, rental, licensing, or any other distribution or use of these drawings, any portion thereof, or the plans depicted hereon is strictly prohibited.

PREPARED BY:
SARAH

DATE:
6-23-21

SCALE:
1/4" = 1'-0"

REVIEWED BY:
PETER

SHEET:
ST-1

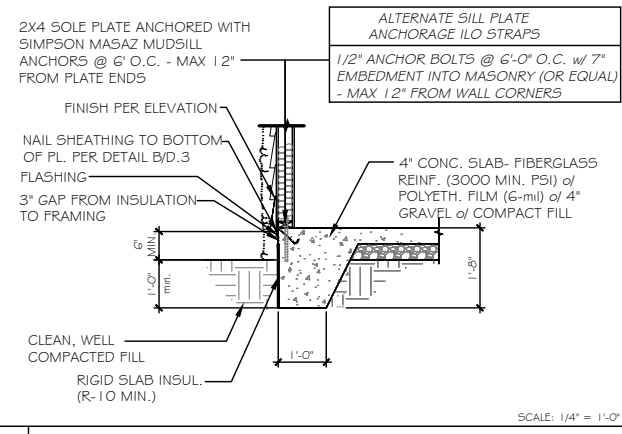

A TYP. SLAB HOUSE TO GRADE

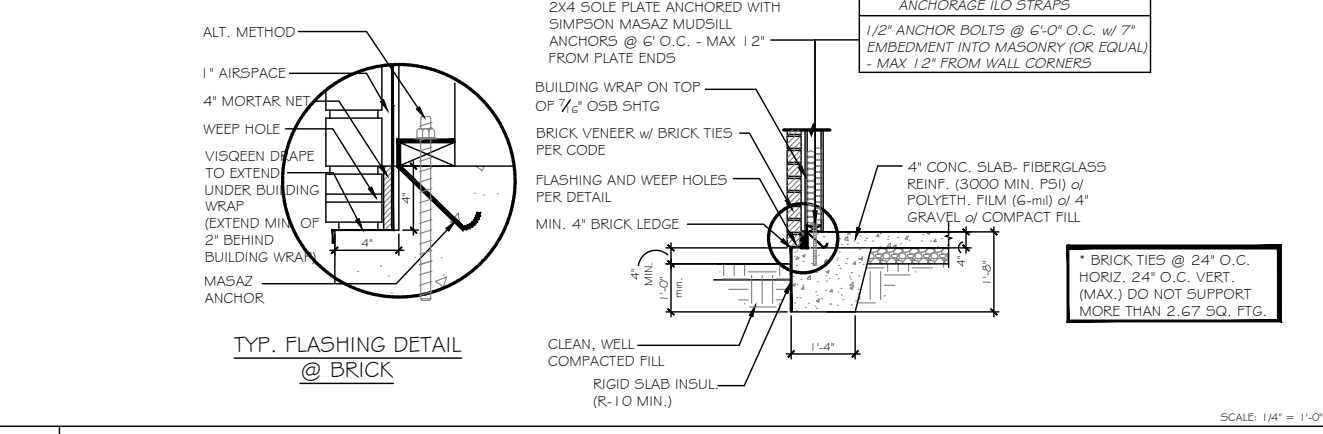

B TYP. SLAB HOUSE TO GRADE w/ BRICK

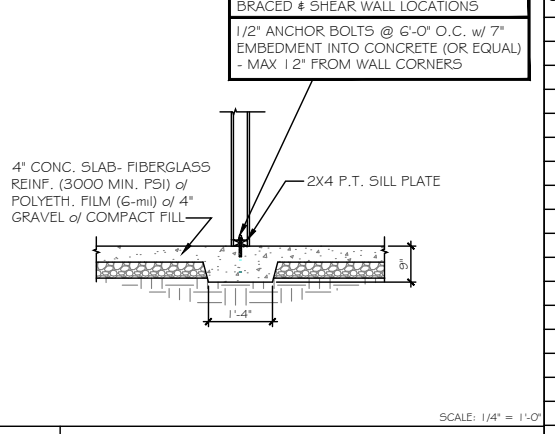

D TYP. THICKENED SLAB DETAIL

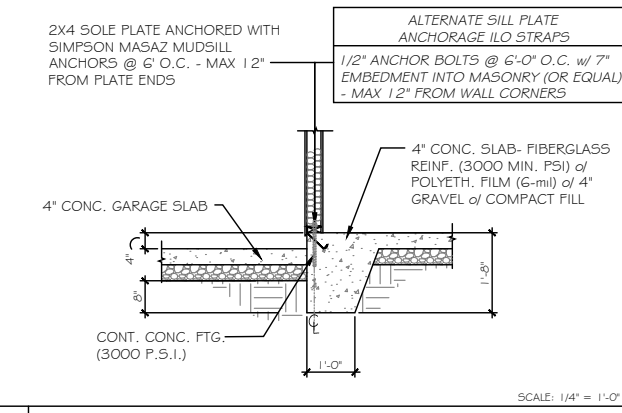

E TYP. SLAB - HOUSE TO GARAGE

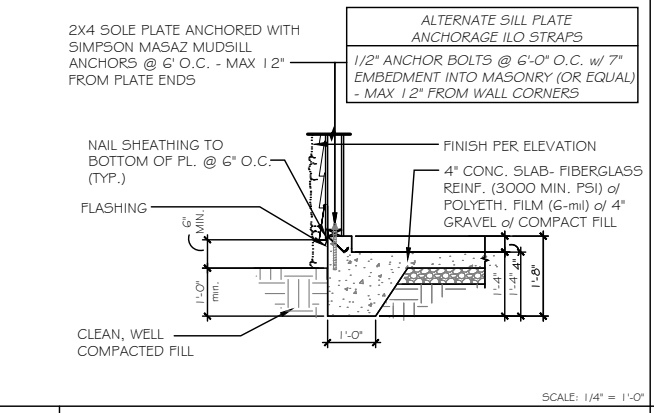

F TYP. SLAB - GARAGE TO GRADE

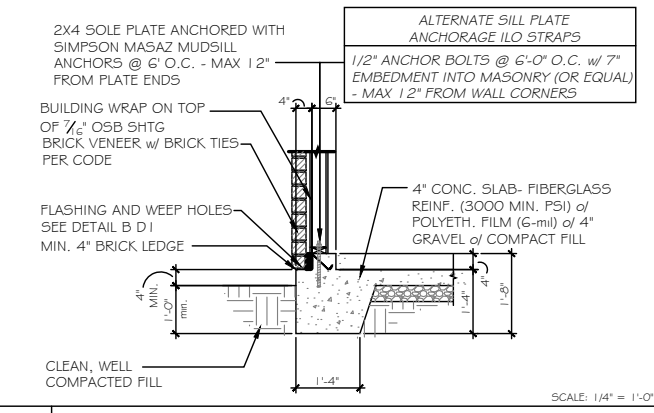

G TYP. SLAB - GARAGE TO GRADE w/ BRICK

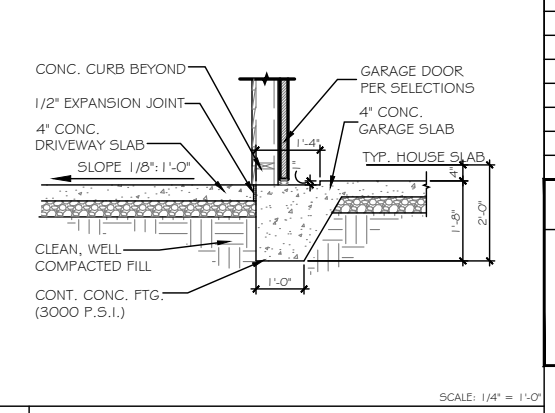

I TYP. GARAGE TO DRIVE

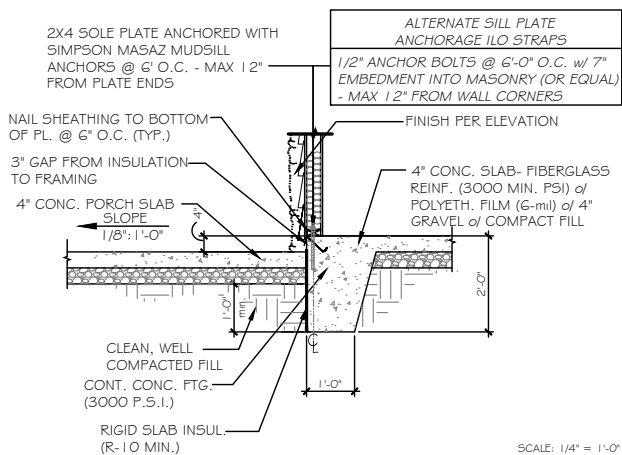

L TYP. SLAB - HOUSE TO PORCH

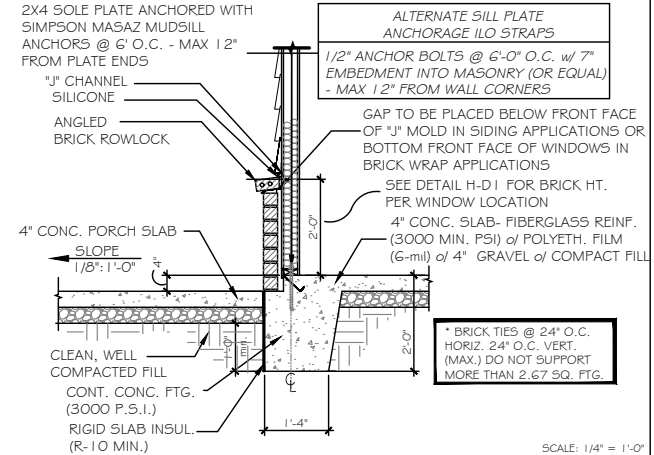

N TYP. SLAB - WAINSCOTING BRICK DETAIL @ PORCH

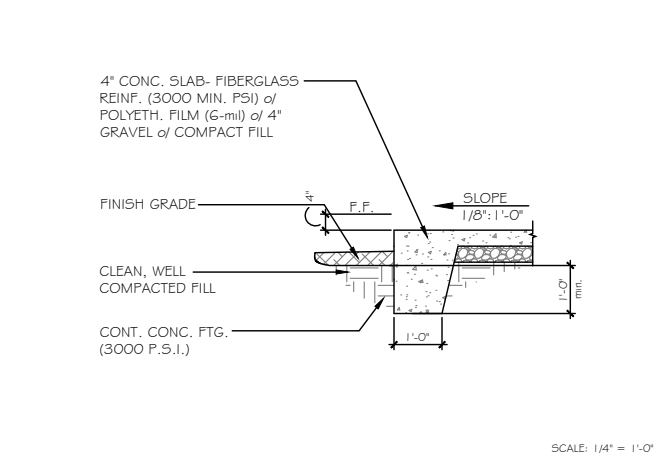

P TYP. PORCH END DETAIL

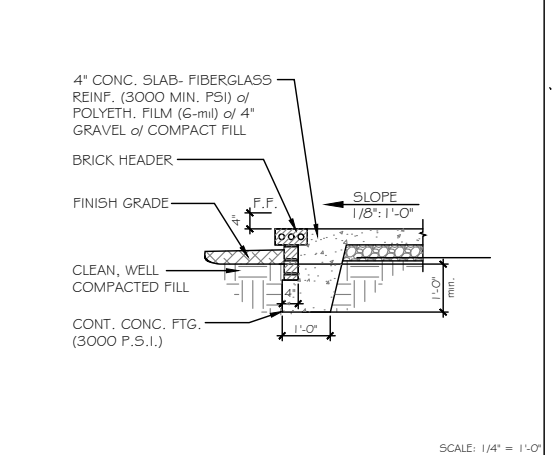

Q PORCH END DETAIL w/ BRICK

MONOSLAB
RALEIGH/TRIAD

NOTES:
CORROSION RESISTANT CORRUGATED METAL TIES - 22 GAUGE, 7/8" WIDE, 6" LONG. PLACE MAX. HORIZONTAL SPACING 24" HORIZ., NOT TO SUPPORT GREATER THAN 2.67 SQ. FT. WALL AREA.
WEEP HOLES TO BE PLACED AT EVERY OTHER HEAD JOINT ON THE BOTTOM COURSE OF BRICK.
VISQUEEN DRAPE TO EXTEND UNDER BUILDING WRAP (EXTEND MIN. OF 2" BEHIND BUILDING WRAP)
PROVIDE WEEP HOLES PER CODES
BRICK TIES @ 24" O.C. HORIZ. 24" O.C. VERT. (MAX.) DO NOT SUPPORT MORE THAN 2.67 SQ. FTG.
BRICK & CMU TO BE INTEGRALLY BONDED PER CODE

REF. NO.	USP
ABA44Z	PA44E-TZ
BC52-2/4	BC4010-TZ
CS-16	RS150
DTT2Z-5D52.5	DTB-TZ
H2.5A	RT7
H2.5A	RT7A
LS-30	MP3
LSTA24	LSTA24
MASAZ	FA3-TZ
STHD14	STAD14
HHUS410	THD410
A24	TDL5
A21	JA1
LSU26	L5SH15-TZ
EPB44	EPB4408
BC6	C66
BC4	C44
LU528-2	JU528-2
LU526	JU526
ABA66	PA66E-TZ
C522	RS-22R
HDU4-5D5	PHD4A
EPB66T	EPB6608
HDQ8-5D3Z	PHD8
LSTA36	LSTA36
A34	MP34

COASTAL & CHARLESTON ONLY
ALTERNATE HOLDDOWN

MITEK PFM1461640 ANCHOR SCREWS w/ 3/4"x3"x3" @ 4' O.C.

MITEK HTT45 HOLDDOWN OR EQ.

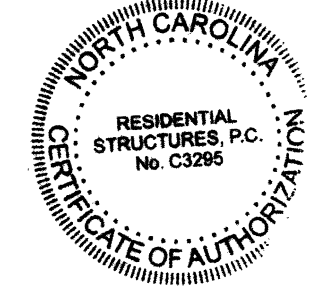
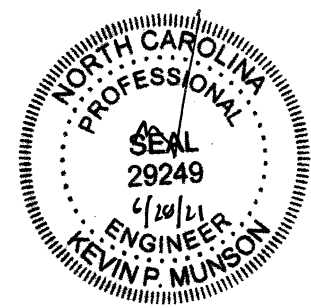

RESIDENTIAL STRUCTURES, P.C.
3410 N. Davidson St.
Charlotte, N.C. 28205
Seal For Structural Only

TrueHomes
IT'S ALL ABOUT YOU
2649 Breckridge Centre Dr.
Suite 104
Monroe, N.C. 28110
704-271-1191

WALKER GROVE
LOT# 13

JASPER 2304
HARNETT

Copyright True Homes L.L.C. All rights reserved. The duplication, reproduction, copying, sale, rental, licensing, or any other distribution or use of these drawings, in whole or in part, without the written consent of True Homes L.L.C. is strictly prohibited.

PREPARED BY:
SARAH
DATE:
6-23-21
SCALE:
1/4" = 1'-0"
REVIEWED BY:
PETER

SHEET:
D1

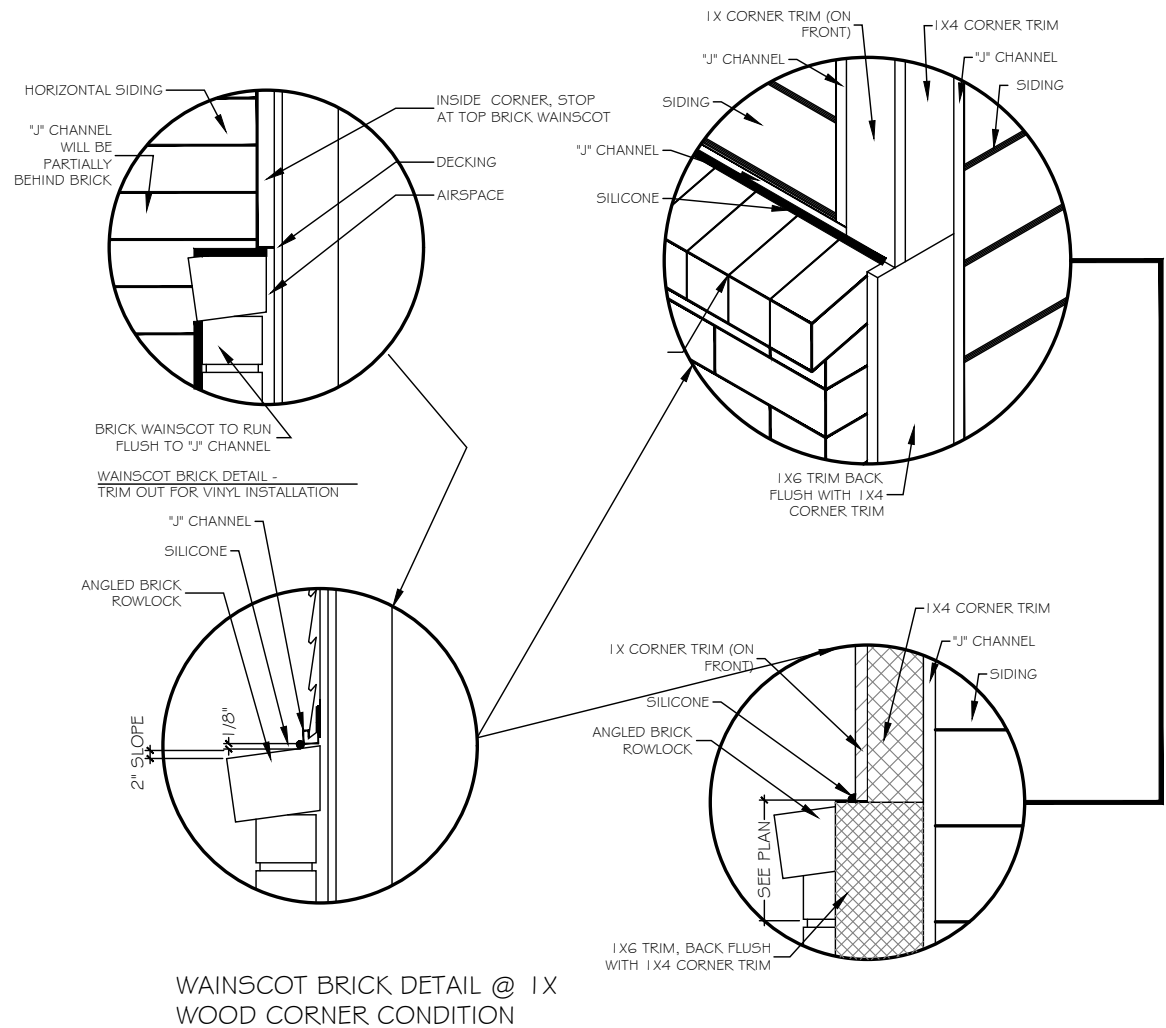

A FLASHING @ WAINSCOTING BRICK DETAIL
SCALE: 1/4" = 1'-0"

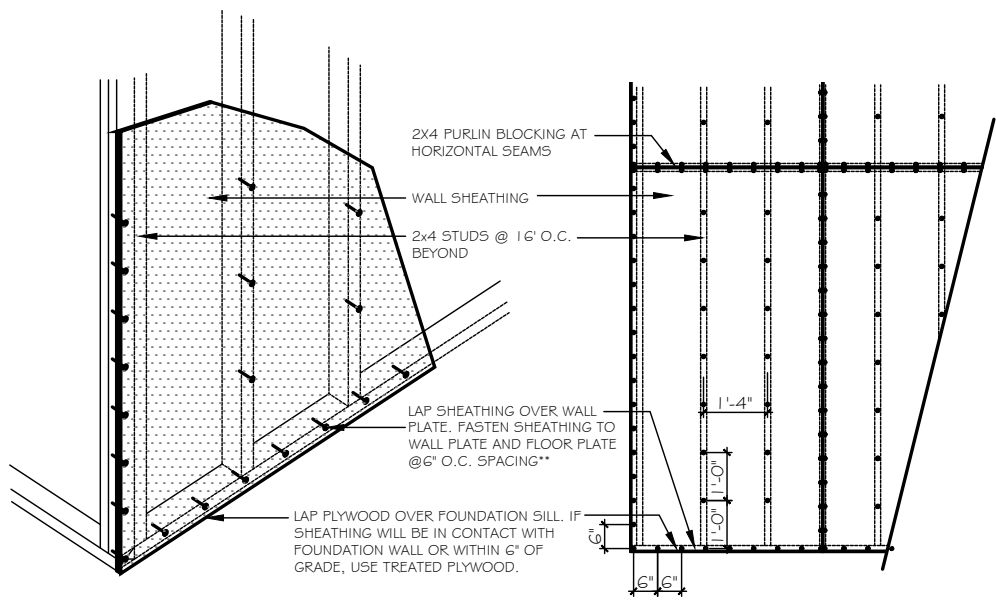

B TYP. NAILING PATTERN
SCALE: 1/4" = 1'-0"

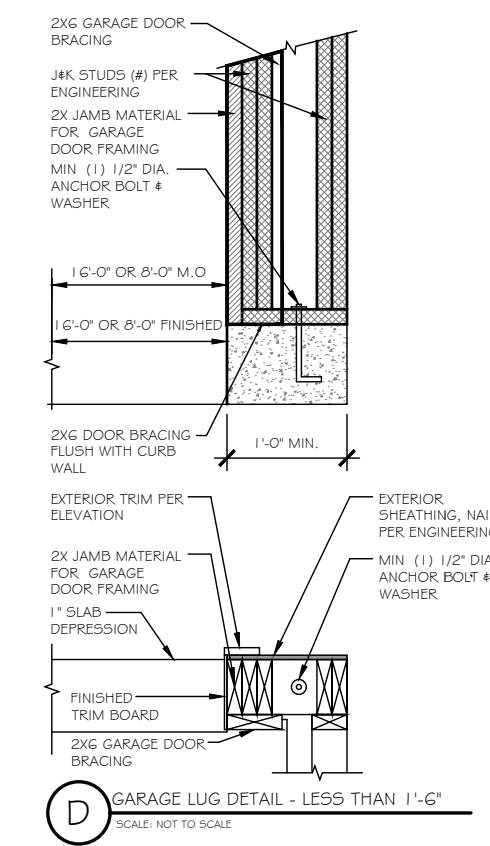
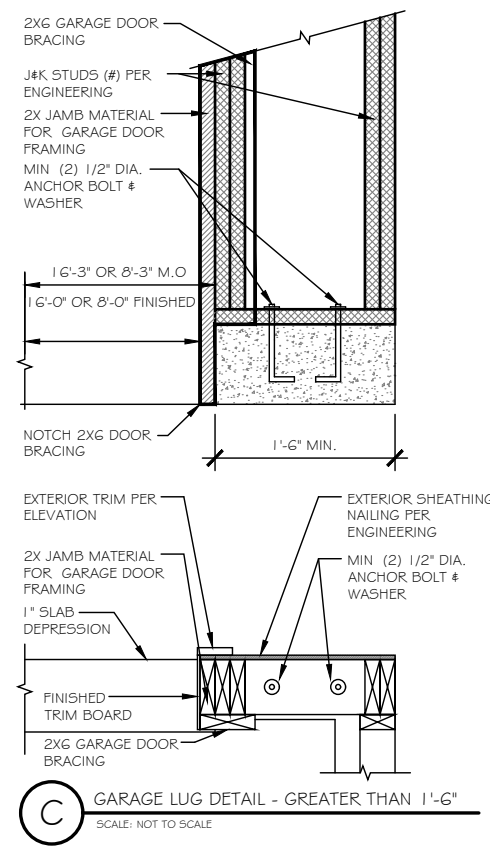

C GARAGE LUG DETAIL - GREATER THAN 1'-6"
SCALE: NOT TO SCALE

D GARAGE LUG DETAIL - LESS THAN 1'-6"
SCALE: NOT TO SCALE

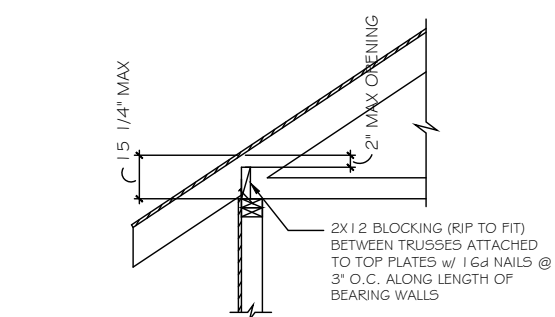

E TRUSS BLOCKING REQUIREMENTS
N.T.S.

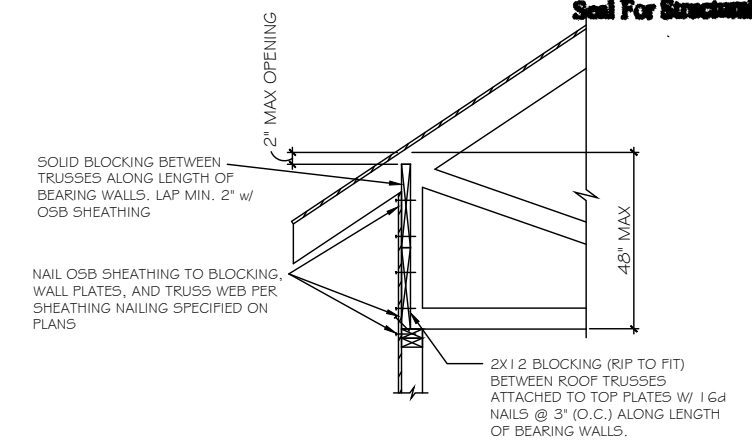

E TRUSS BLOCKING REQUIREMENTS
N.T.S.

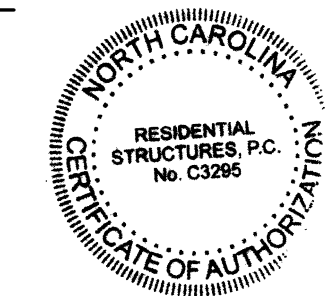
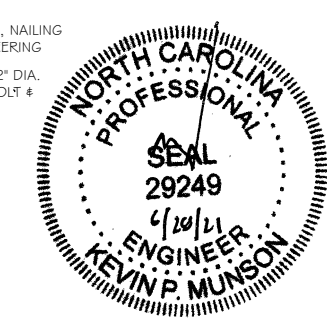

RESIDENTIAL STRUCTURES, P.C.
3410 N. Davidson St.
Charlotte, N.C. 28205
Seal For Structural Only

TrueHomes
IT'S ALL ABOUT YOU
2649 Breckridge Centre Dr.
Suite 104
Monroe, N.C. 28110
704-271-1191

WALKER GROVE
LOT# 13

JASPER
2304

HARNETT

Copyright True Homes L.L.C. All rights reserved. The duplication, reproduction, copying, sale, rental, licensing, or any other distribution or use of these drawings, any portion thereof, or the plans depicted herein is strictly prohibited.
PREPARED BY:
SARAH
DATE:
6-23-21
SCALE:
AS SHOWN
REVIEWED BY:
PETER

SHEET:
D3

WALL BRACING HAS BEEN DESIGNED IN ACCORDANCE WITH THE 2018 NCRC AND/OR THE 2018 IRC AS ALLOWED PER SECTION R602.10.

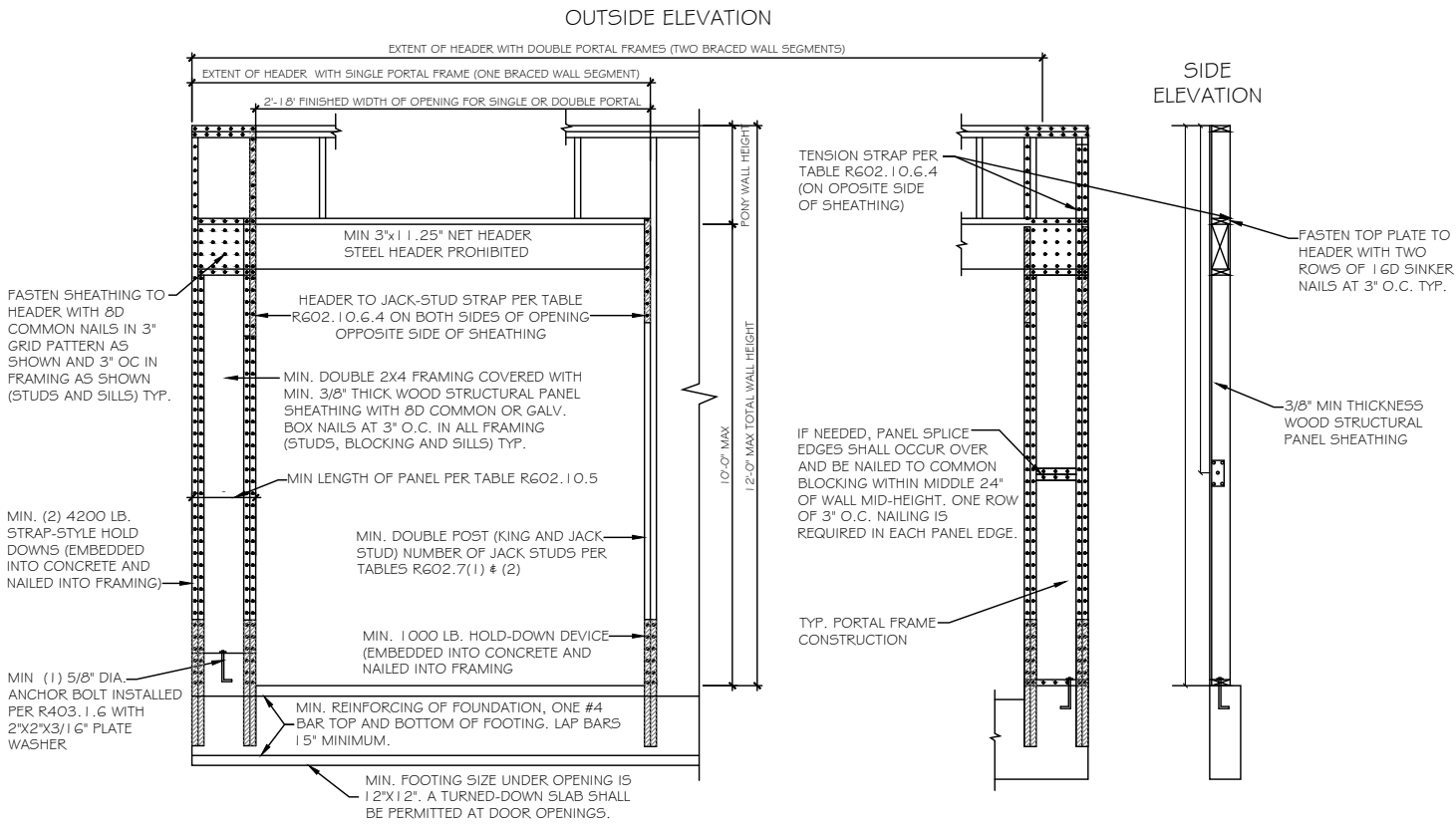

A PORTAL FRAME METHOD PFH DETAIL

SCALE: 3/8" = 1'-0"

AS A SUBSTITUTE FOR THE USP STAD14 HOLD-DOWN STRAPS LOCATED ON EACH SIDE OF THE GARAGE DOOR OPENING, SIMPSON HDQ8-SD53 (OR USP PHD8) HOLD-DOWNS MAY BE INSTALLED. THE SIMPSON HDQ8-SD53 (USP PHD8) HOLD-DOWNS MAY BE INSTALLED WITH 7/8" THREADED ROD AND SHOULD BE EMBEDDED A MINIMUM OF 8" INTO THE CONCRETE FOOTING OR GROUTED CMU BLOCK WITH HIGH STRENGTH EPOXY. ADDITIONALLY, A 5/8" EXPANSION ANCHOR (6" MIN EMBEDMENT) OR 5/8"x 6" SIMPSON TITEN HD ANCHOR MAY BE INSTALLED AS A REPLACEMENT FOR THE 5/8" "WET SET" ANCHOR BOLT SHOWN IN THE PORTAL FRAMING WITH HOLD-DOWNS DETAIL.

PFH METHOD: PORTAL FRAME WITH HOLD DOWNS GARAGE DOORS AND OPENINGS 6' TO 18'

REF NO.	USP
ABA44Z	PA44E-TZ
BCS2-2/4	BC4010-TZ
C5-1G	R5150
DTT2Z-SD52.5	DTB-TZ
H2.5A	RT7
H2.5A	RT7A
L5-30	MP3
LSTA24	LSTA24
MASAZ	FA3-TZ
STHD14	STAD14
HHU5410	THD410
A24	TDL5
A21	JA1
LSU26	LSSH15-TZ
EPB44	EPB4408
BC6	C66
BC4	C44
LUS28-2	JUS28-2
LUS26	JUS26
ABAGG	PAGGE-TZ
CS22	RS-22R
HDU4-SD5	PHD4A
EPB66T	EPB6608
HDQ8-SD3Z	PHD8
LSTA36	LSTA36
A34	MP34

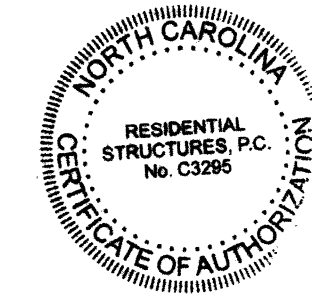
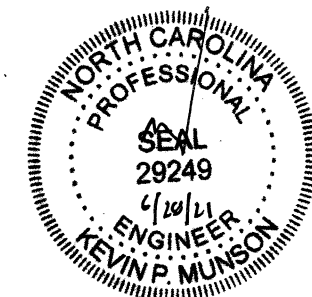

RESIDENTIAL STRUCTURES, P.C.
3410 N. Davidson St.
Charlotte, N.C. 28205
Seal For Structural Only

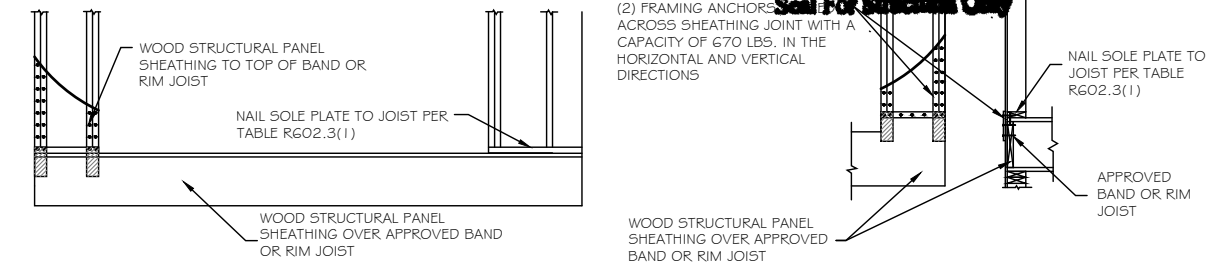

A OVER RAISED WOOD FLOOR - FRAMING ANCHOR OPTION

SCALE: 3/8" = 1'-0" (WHEN PORTAL SHEATHING DOES NOT LAP OVER BAND OR RIM JOIST)

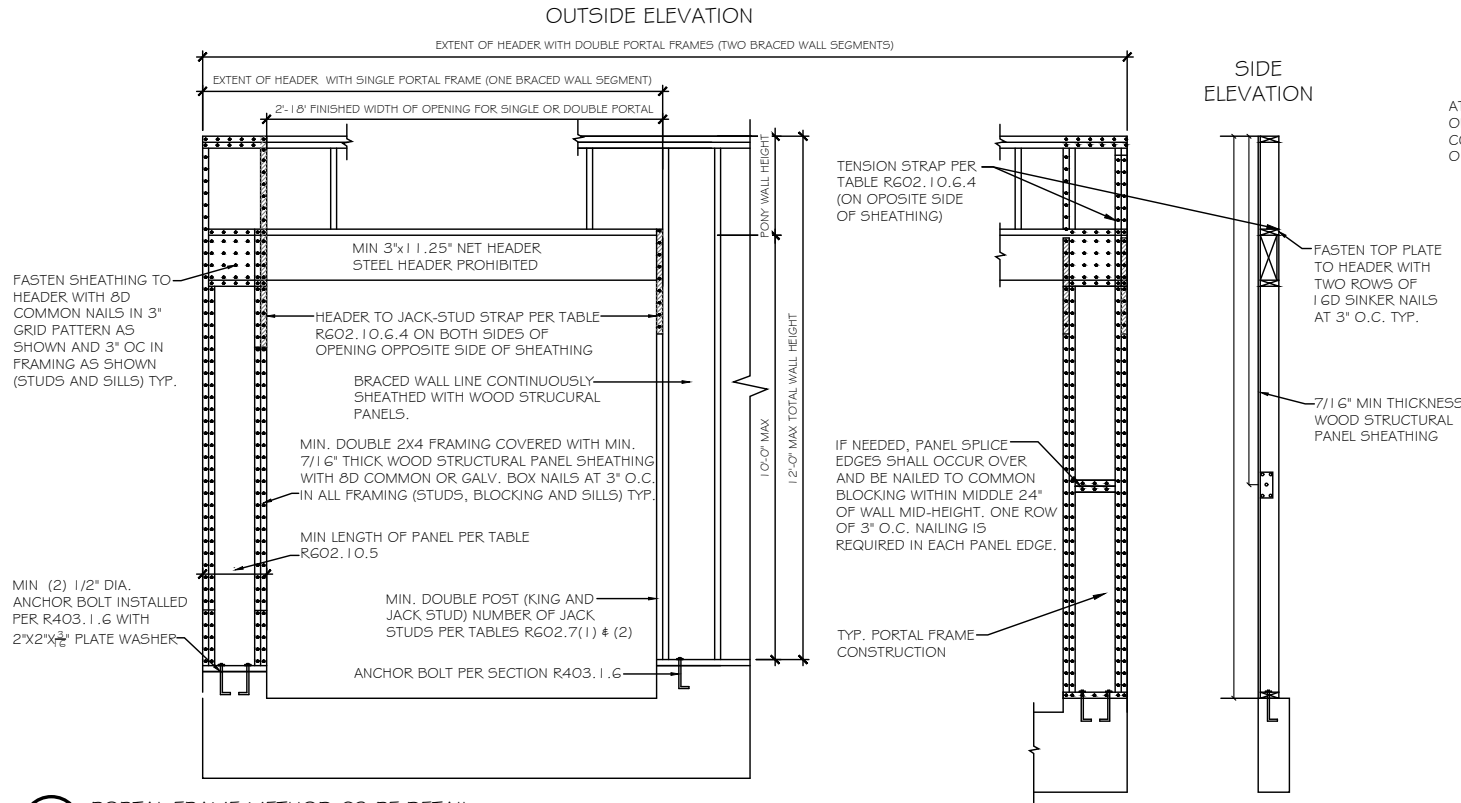

A PORTAL FRAME METHOD CS-PF DETAIL

SCALE: 3/8" = 1'-0"

CS-PF METHOD: CONTINUOUSLY SHEATHED PORTAL FRAME-GARAGE DOOR GARAGE DOORS AND OPENINGS 6' AND GREATER

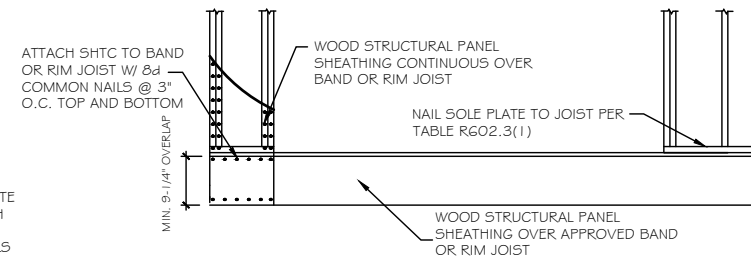

B OVER RAISED WOOD FLOOR - OVERLAP OPTION

SCALE: 3/8" = 1'-0" (WHEN PORTAL SHEATHING LAPS OVER BAND OR RIM JOIST)

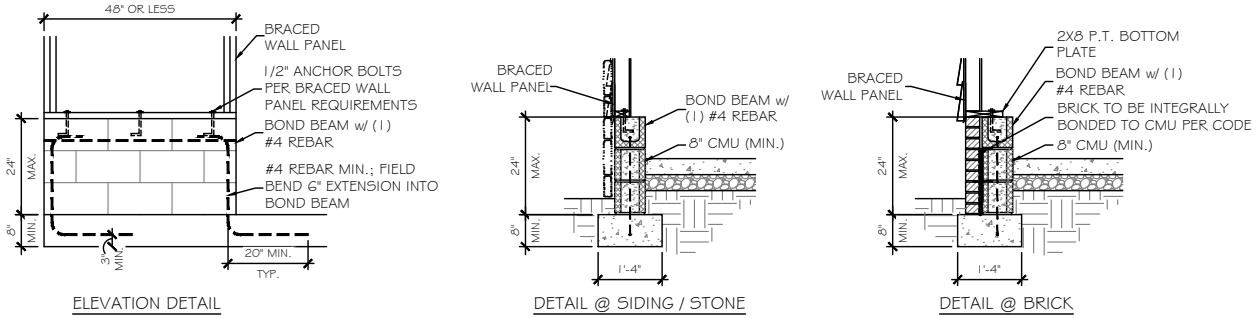

C MASONRY STEM WALL SUPPORTING BRACED WALL PANEL DETAILS

SCALE: 3/8" = 1'-0"

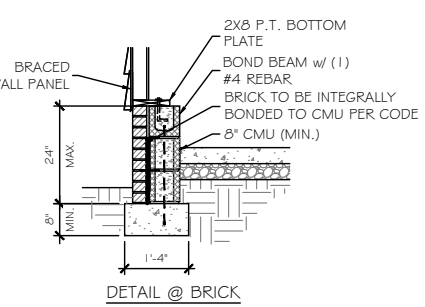

PER 2018 I.R.C. SHORT STEM WALL REINFORCEMENT

TrueHomes
IT'S ALL ABOUT U
2649 Breckridge Centre Dr.
Suite 104
Monroe, N.C. 28110
704-271-1191

WALKER GROVE
LOT# 13

JASPER
2304
HARNETT

Copyright True Homes L.L.C. All rights reserved. The duplication, reproduction, copying, sale, rental, licensing, or any other distribution or use of these drawings, any portion thereof, or the plans depicted herein is strictly prohibited.
PREPARED BY:
SARAH
DATE:
6-23-21
SCALE:
AS SHOWN
REVIEWED BY:
PETER

SHEET:
D4

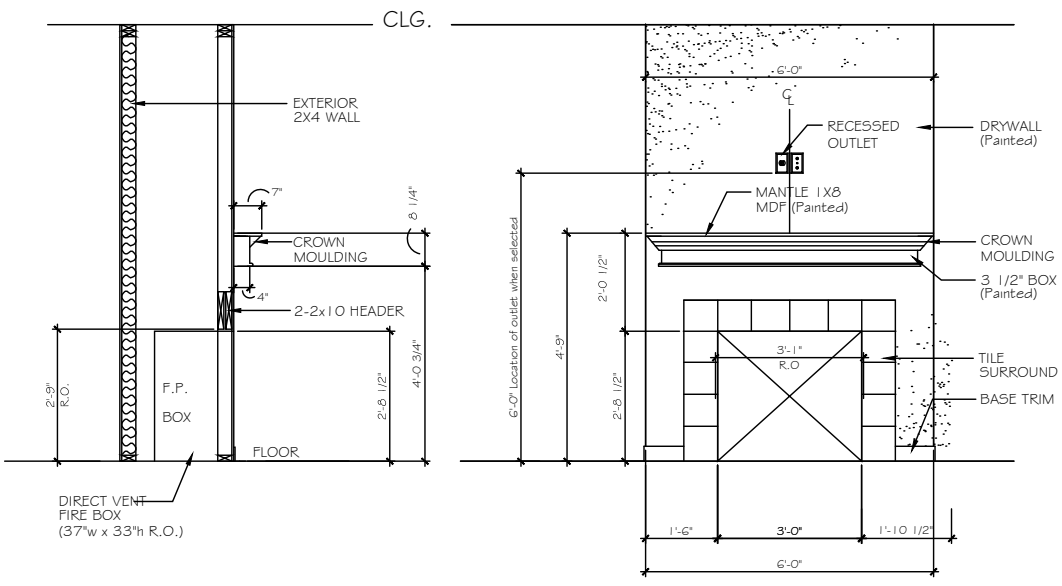

A FIREPLACE OPTION 1
SCALE: 3/8" = 1'-0"

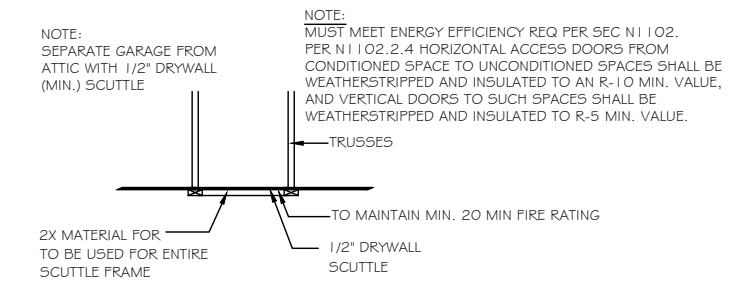

B ATTIC ACCESS PANEL DETAIL
SCALE: N.T.S.

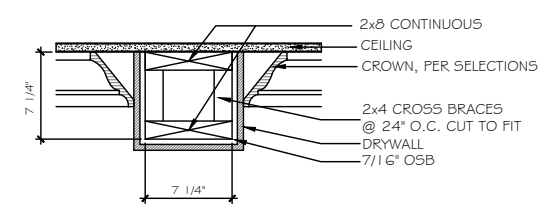

C 8" DRYWALL BEAM DETAIL - LIVING/DINING/STUDY
SCALE: N.T.S.

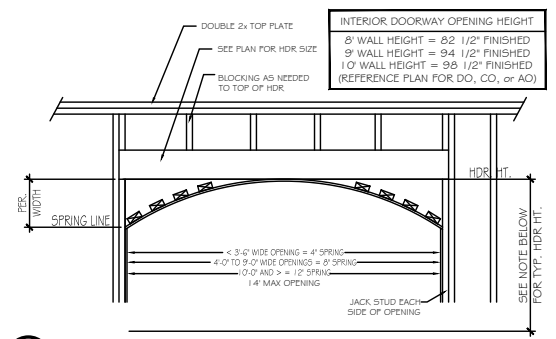

D ARCHED OPENING DETAIL
SCALE: 3/8" = 1'-0"

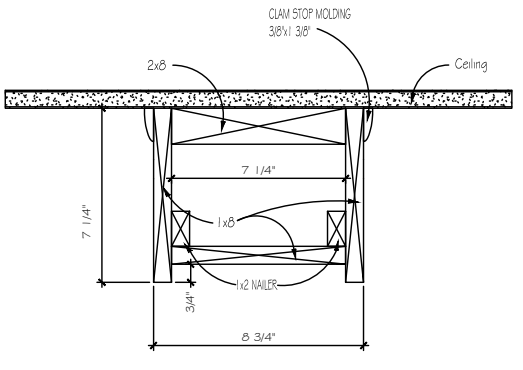

E 9" CEILING
*WOOD FAUX BEAMS KITCHEN/NOOK ONLY

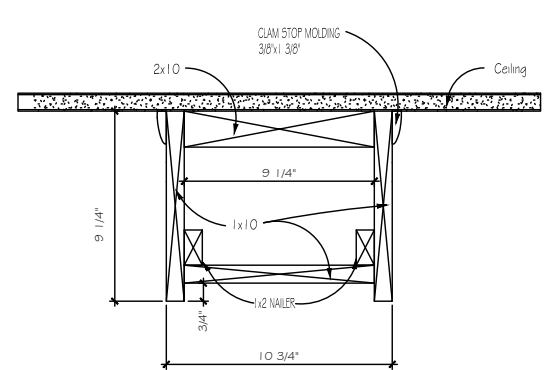

F 10" CEILING
*WOOD FAUX BEAMS KITCHEN/NOOK ONLY

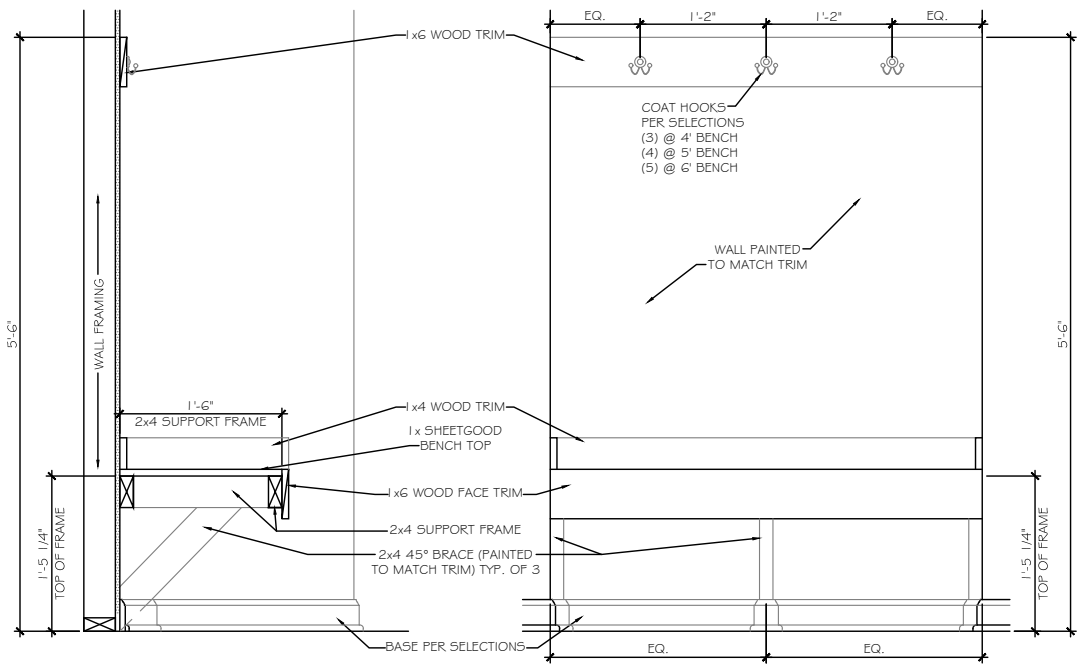

SECTION AT OPEN BENCH
SCALE: NOT TO SCALE WALL END CONDITION

ELEVATION AT OPEN BENCH
SCALE: NOT TO SCALE WALL END CONDITION

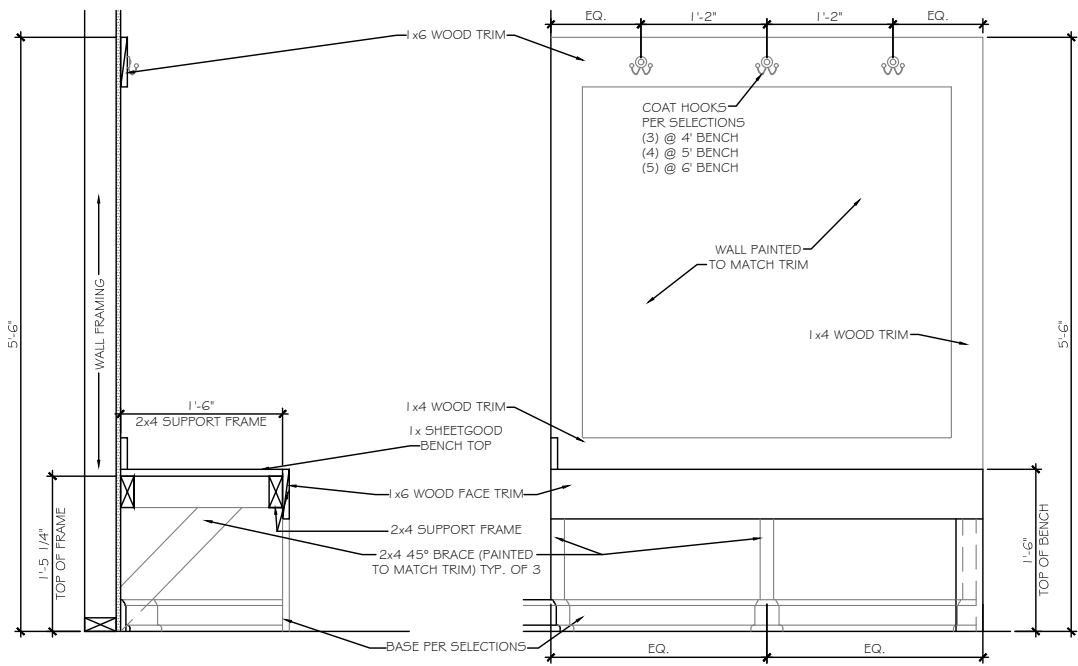
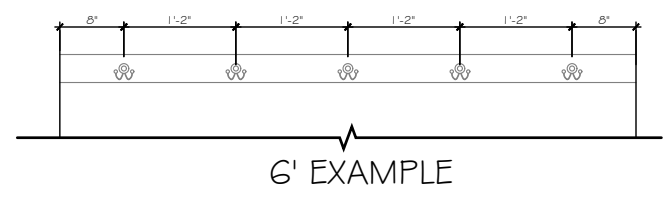
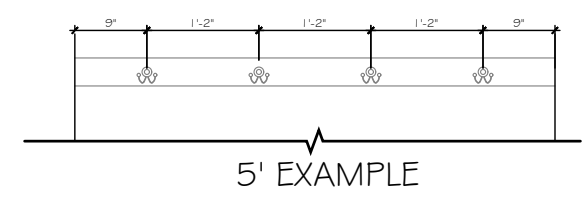

SECTION AT OPEN BENCH
SCALE: NOT TO SCALE OPEN END CONDITION

ELEVATION AT OPEN BENCH
SCALE: NOT TO SCALE OPEN END CONDITION

TrueHomes
IT'S ALL ABOUT U
2649 Breckridge Centre Dr.
Suite 104
Monroe, N.C. 28110
704-271-1191

WALKER GROVE
LOT# 13

JASPER
2304

HARNETT

Copyright True Homes L.L.C. All rights reserved. The duplication, reproduction, copying, sale, rental, licensing, or any other distribution or use of these drawings, any portion thereof, or the plans depicted herein is strictly prohibited.

PREPARED BY:
SARAH
DATE:
6-23-21
SCALE:
AS SHOWN
REVIEWED BY:
PETER

SHEET:
D5

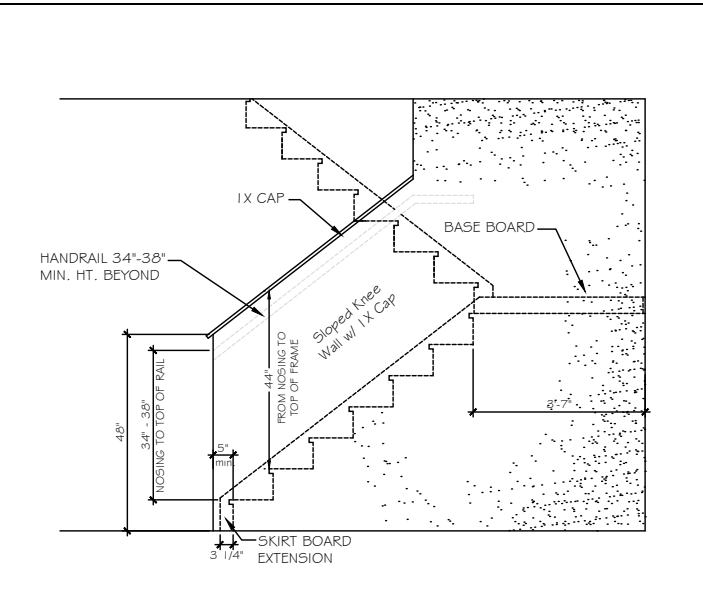

ST-1 48° SLOPED WALL w/ 1x CAP

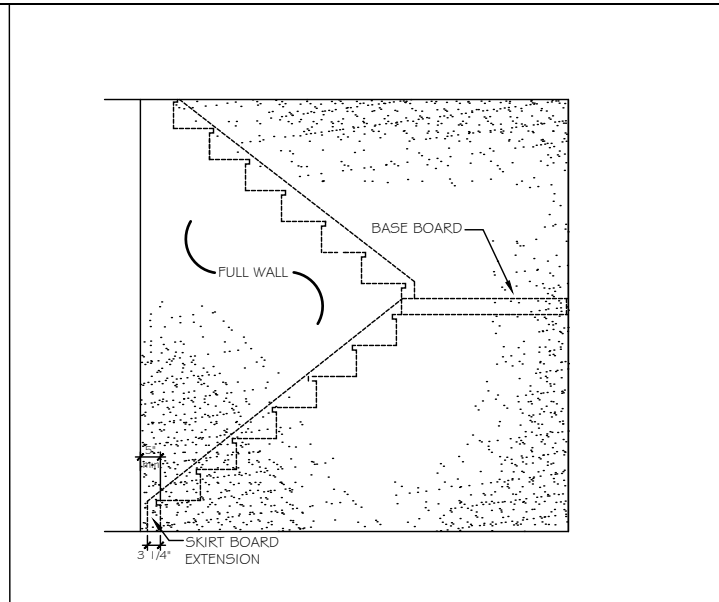

ST-2 FULL WALL

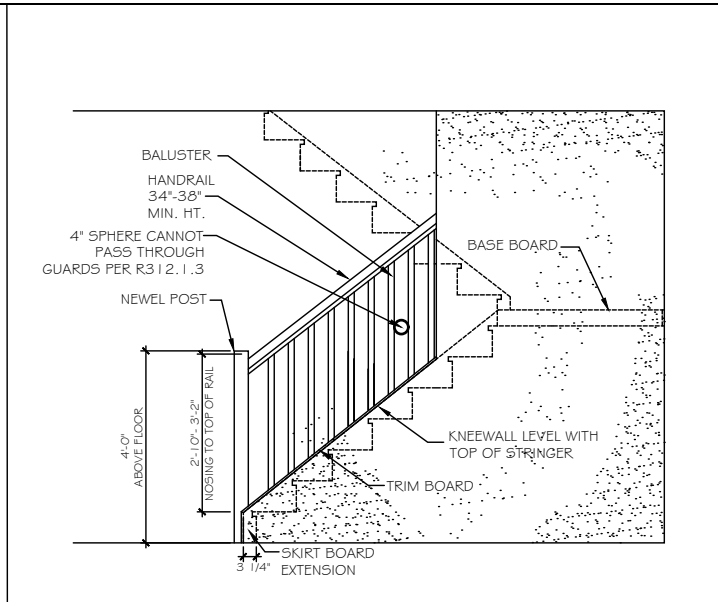

ST-3 OPT. OPEN RAIL

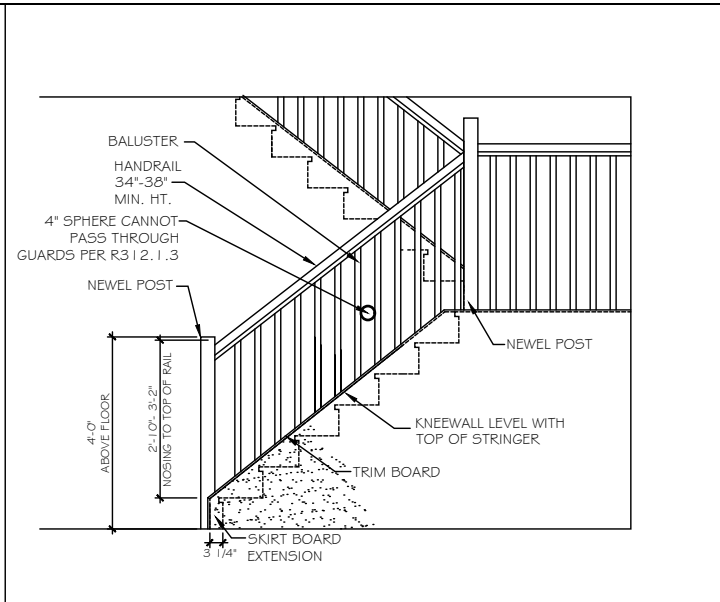

ST-4 OPT. OPEN RAIL FULL STAIR

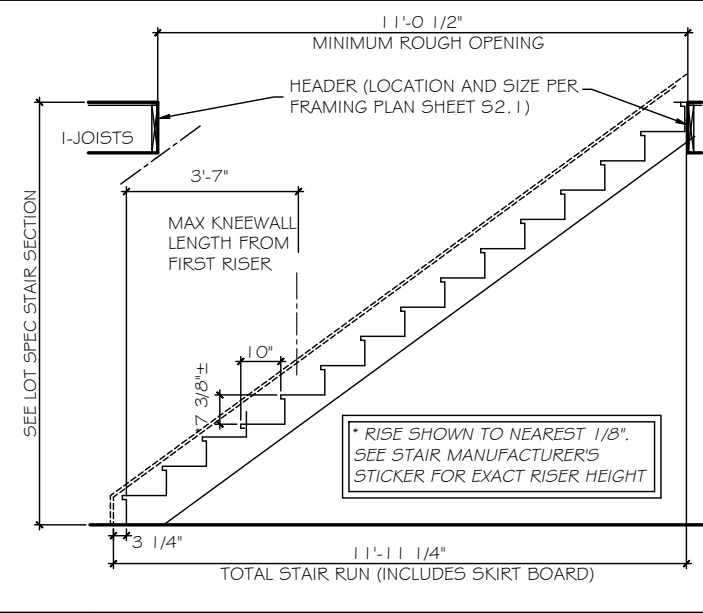

ST-5 STRAIGHT STAIR SECTION - 8ft CEILING HEIGHT w/ 11 7/8" FLOOR SYSTEM

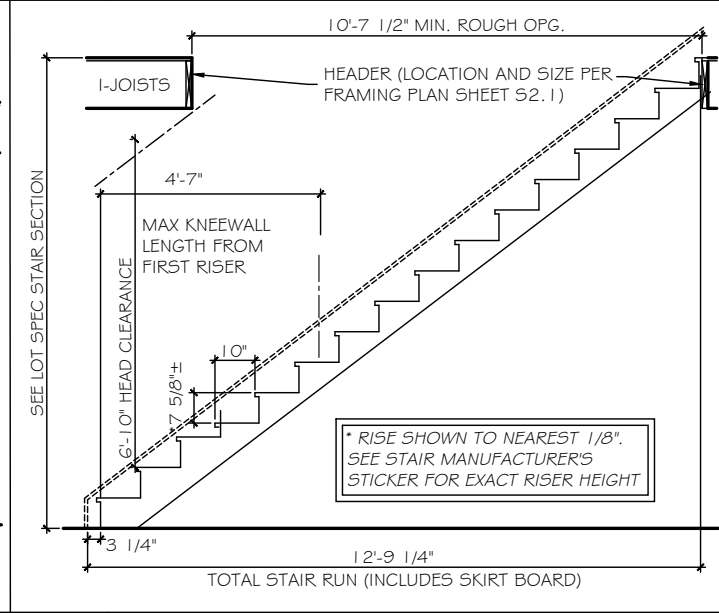

ST-6 STRAIGHT STAIR SECTION - 9ft CEILING HEIGHT w/ 11 7/8" FLOOR SYSTEM

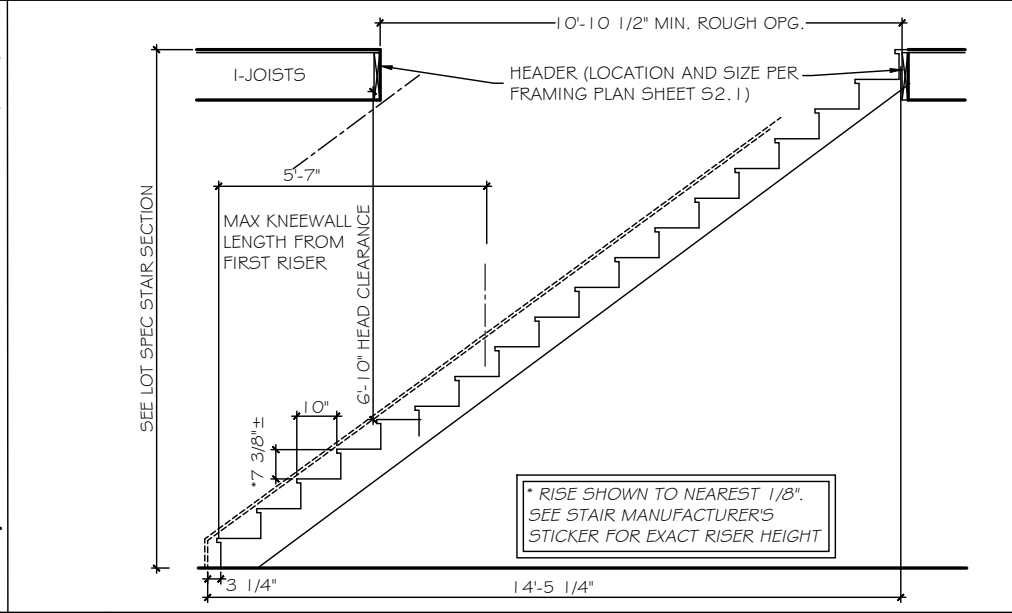

ST-7 STRAIGHT STAIR SECTION - 10ft CEILING HEIGHT w/ 11 7/8" FLOOR SYSTEM

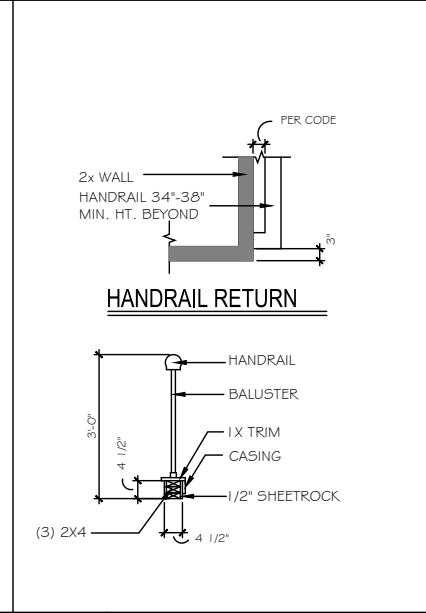

ST-8 HANDRAILS

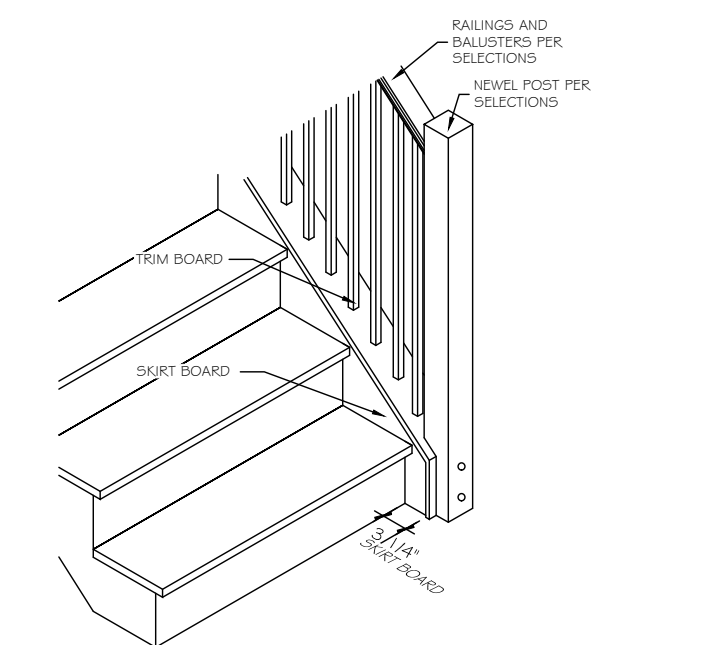

ST-9 OPT. OPEN RAIL - ISO

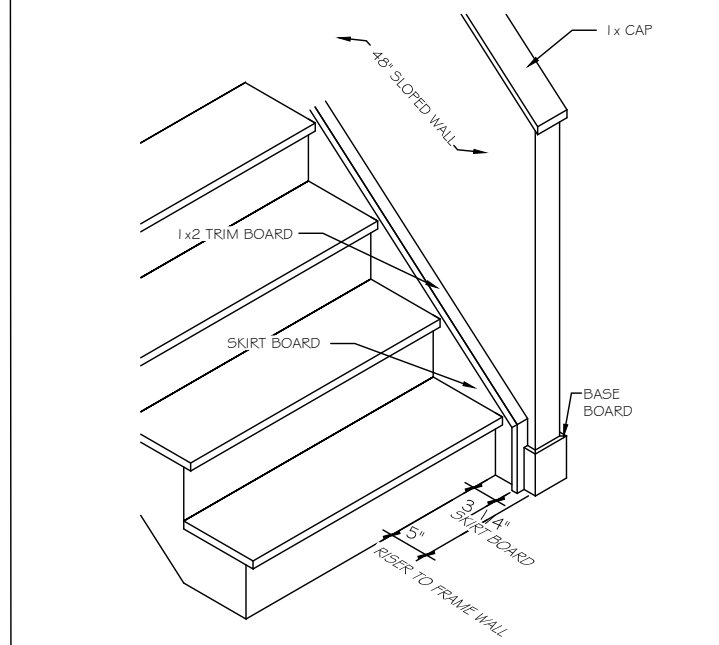

ST-10 48° SLOPED WALL w/ 1x CAP - ISO

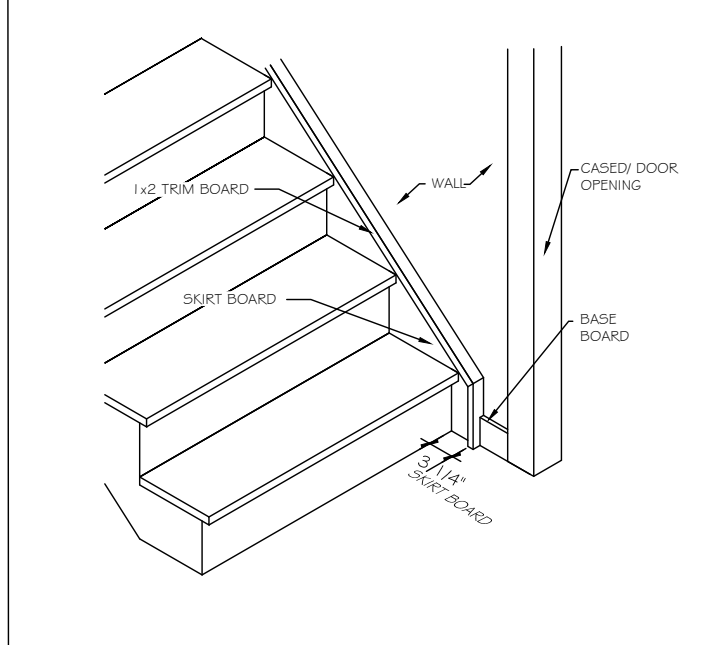

ST-11 STAIRS @ CASSED OPENING - ISO

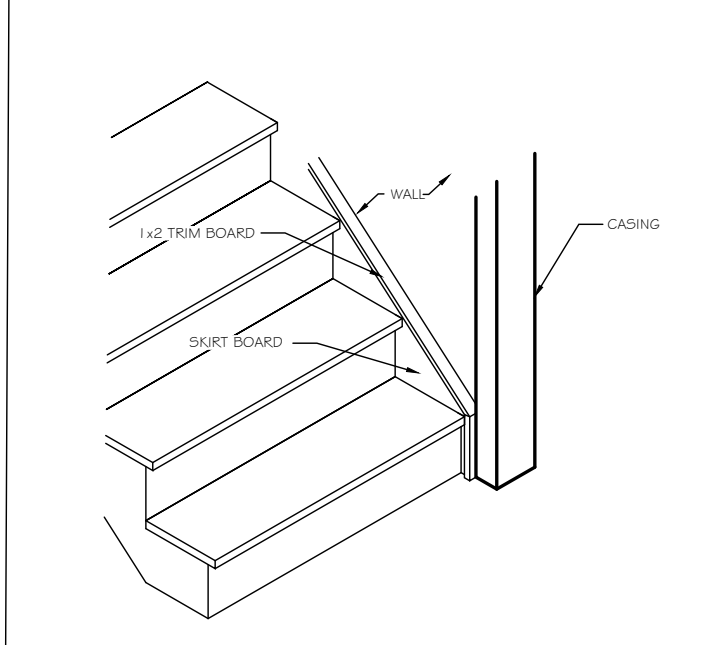

ST-12 TRIM SKIRT BOARD @ CASSED OPENING

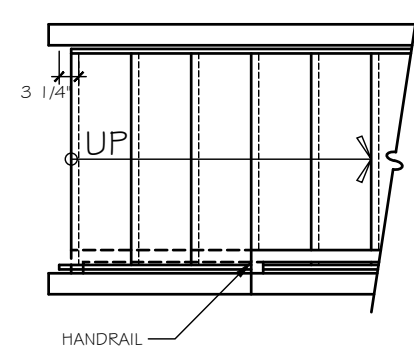
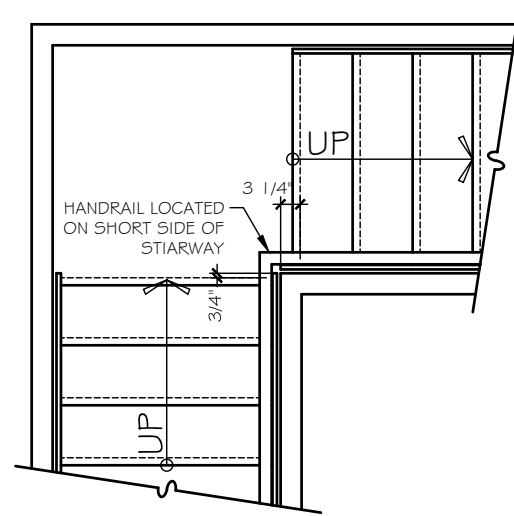
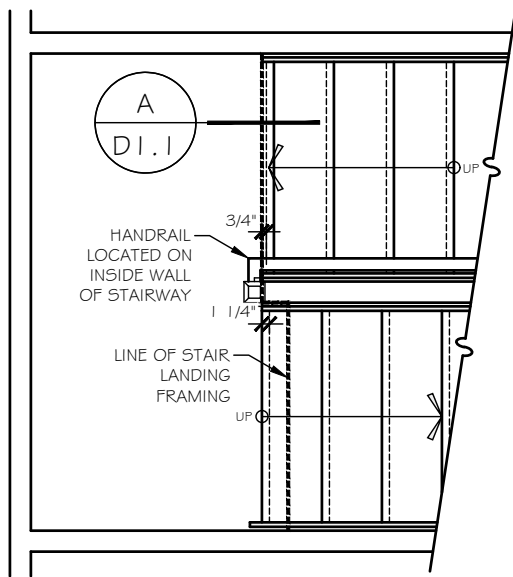
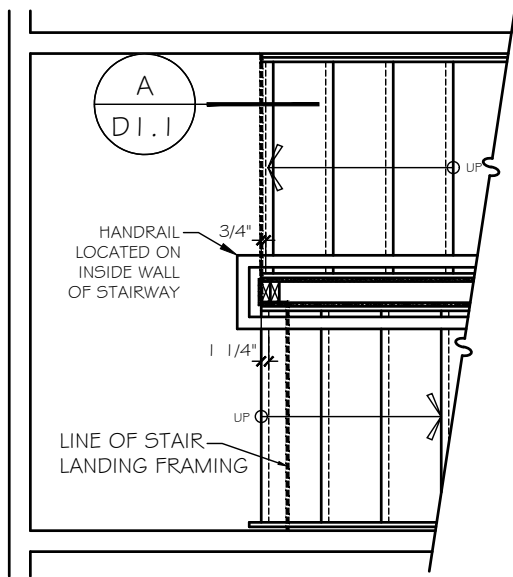

FOR STRAIGHT RUN STAIRWAYS WITHOUT AN INTERMEDIATE LANDING BETWEEN FLOORS, THE HANDRAIL SHOULD BE LOCATED ON THE SAME SIDE AS A FIRST FLOOR HALF WALL OR OPEN RAIL; IF BOTH SIDES HAVE A FIRST FLOOR HALF WALL OR OPEN RAIL, OR IF NONE EXIST, LOCATE THE HANDRAIL ON THE RIGHT SIDE OF THE STAIRWAY

ST-13 STAIR LANDING HALF WALL w/ CAP

ST-14 STAIR LANDING NEWEL POST & BALUSTRADES

ST-15 STAIR LANDING FULL WALL

ST-15a STAIR w/o INTERMEDIATE LANDING

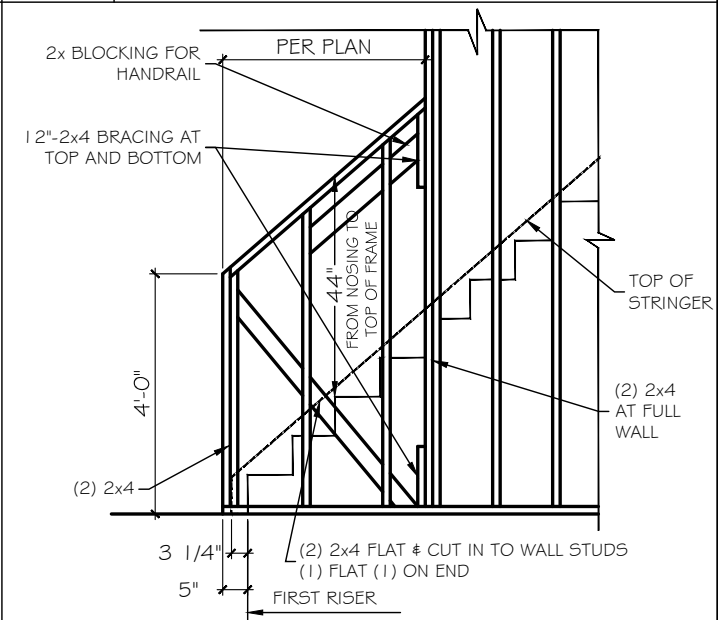
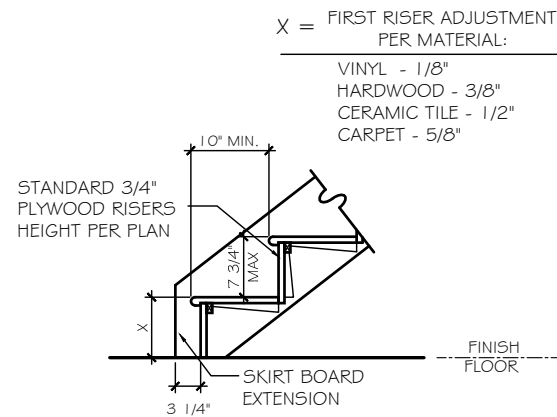
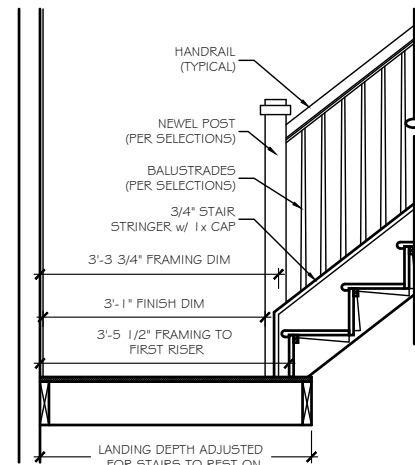
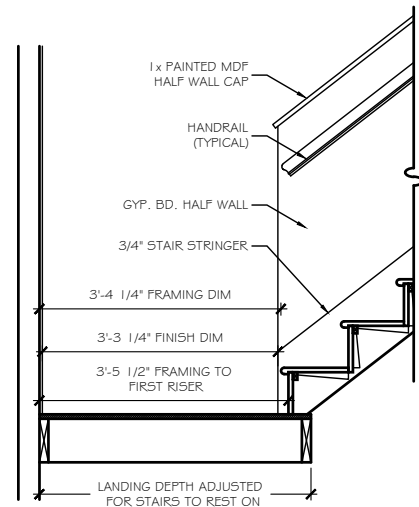

ST-17 SECTION A- SLOPED WALL

ST-18 SECTION A- OPEN RAIL

ST-19 STAIR SECTION - FIRST FLOOR

ST-16 SLOPED WALL @ STAIRS - FRAMING

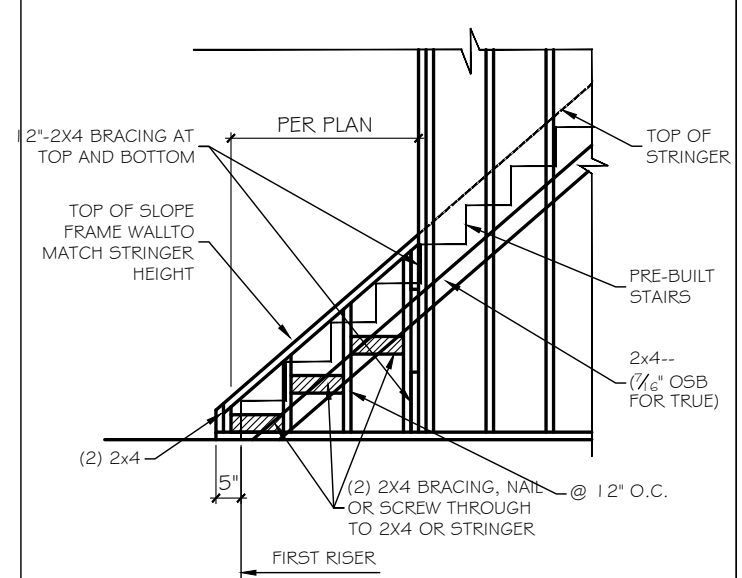
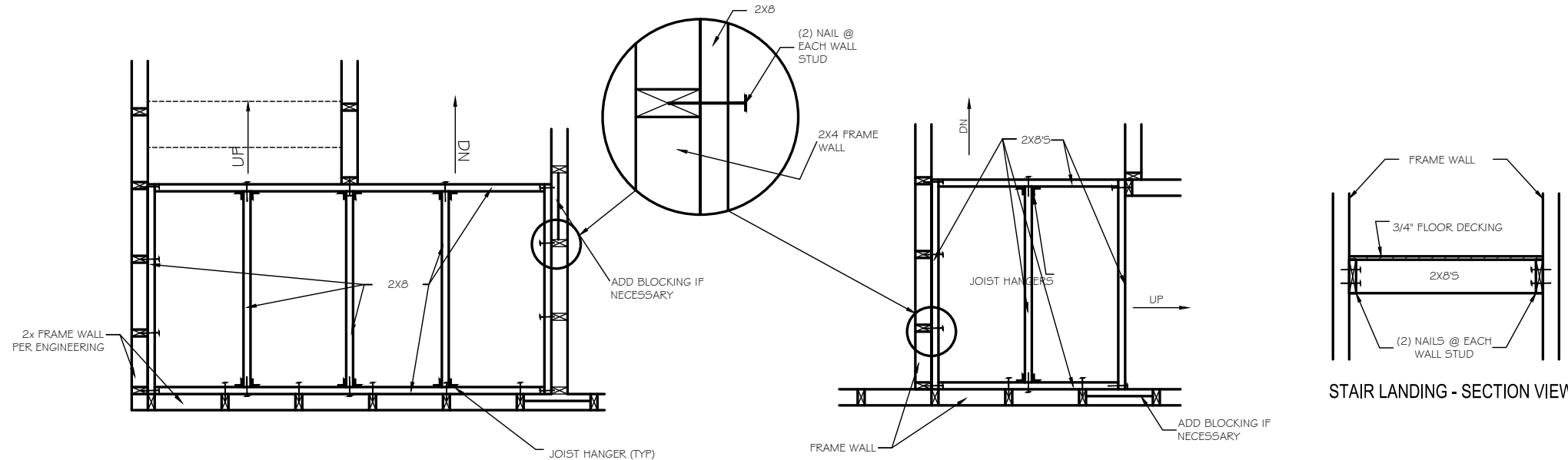

ST-21 STAIR LANDING - PLAN VIEW

ST-20 OPEN RAIL - CURB WALL FRAMING

TrueHomes
IT'S ALL ABOUT U
2649 Breckridge Centre Dr.
Suite 104
Monroe, N.C. 28110
704-271-1191

WALKER GROVE

LOT# 13

JASPER
2304

HARNETT

Copyright True Homes L.L.C. All rights reserved. The duplication, reproduction, copying, sale, rental, licensing, or any other distribution or use of these drawings, any portion thereof, or the plans depicted hereon is strictly prohibited.

PREPARED BY:
SARAH
DATE:
6-23-21
SCALE:
AS SHOWN
REVIEWED BY:
PETER

SHEET:
D5.2

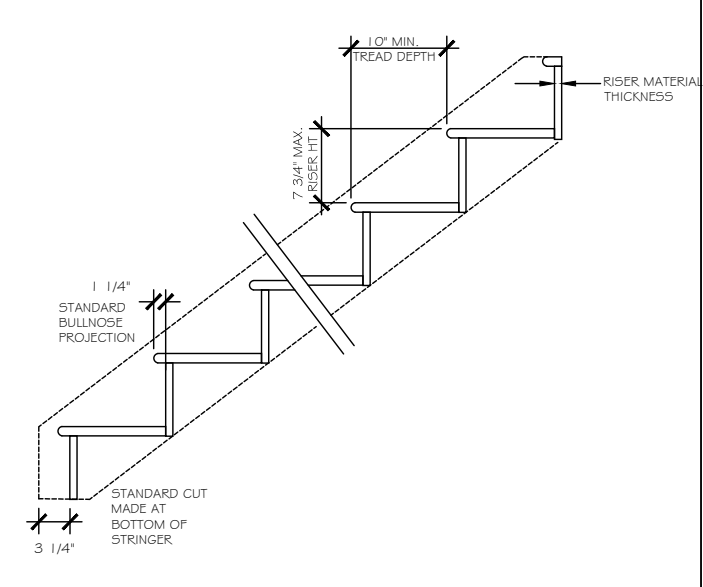
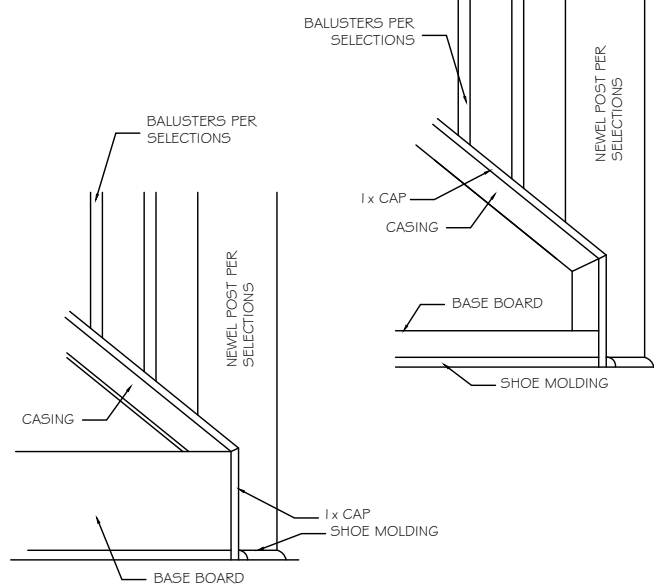
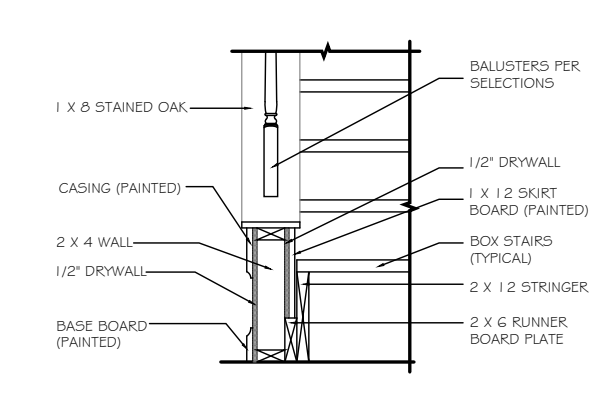
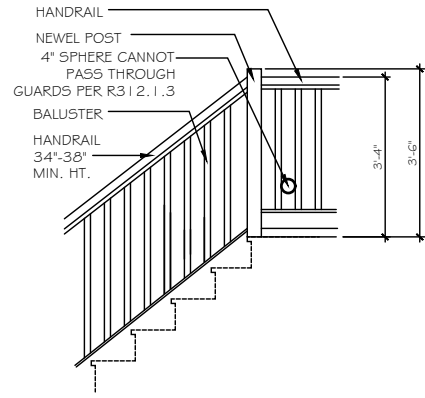

ST-23 OPT. OPEN RAIL AT LANDING

ST-24 SECTION @ CURB WALL

ST-25 OUTSIDE TRIM @ STAIR CURB WALL

STAIR SECTION

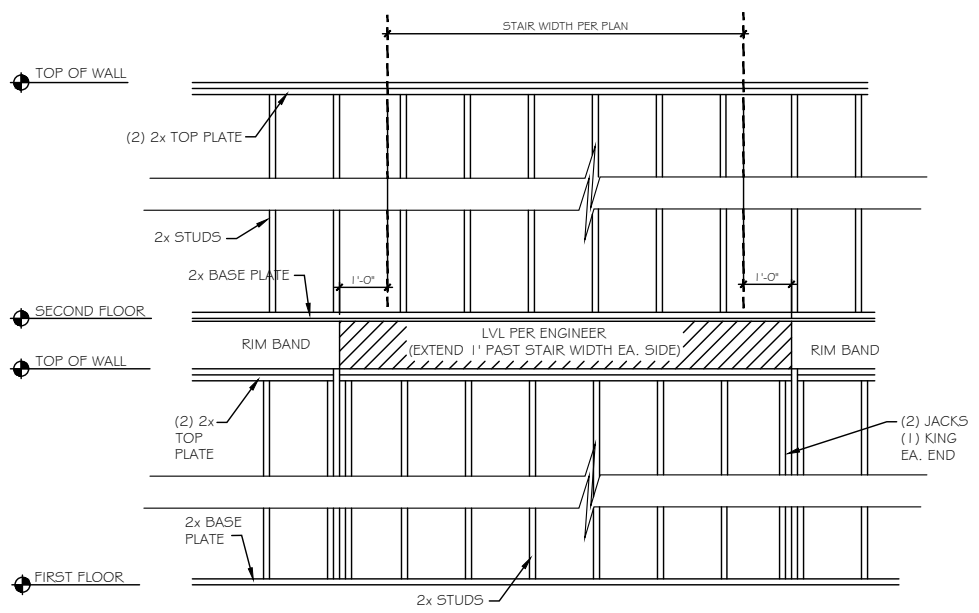
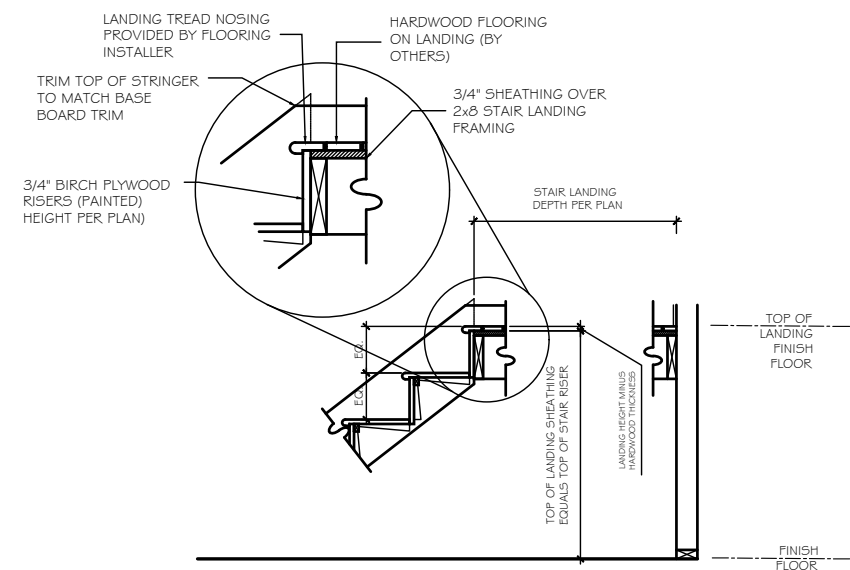

ST-26 STAIR SECTION - HARDWOOD STAIRS AND LANDING

ST-28 EXTERIOR WALL FRAMING @ U-SHAPED STAIRS in BALLOON FRAMING

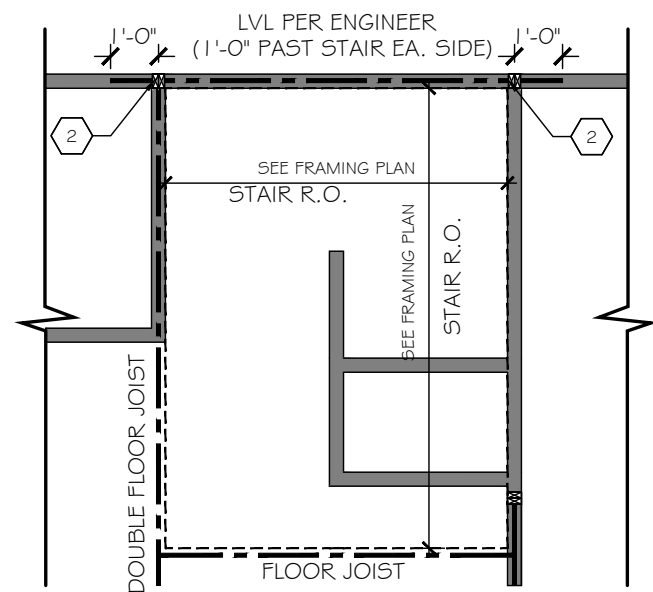
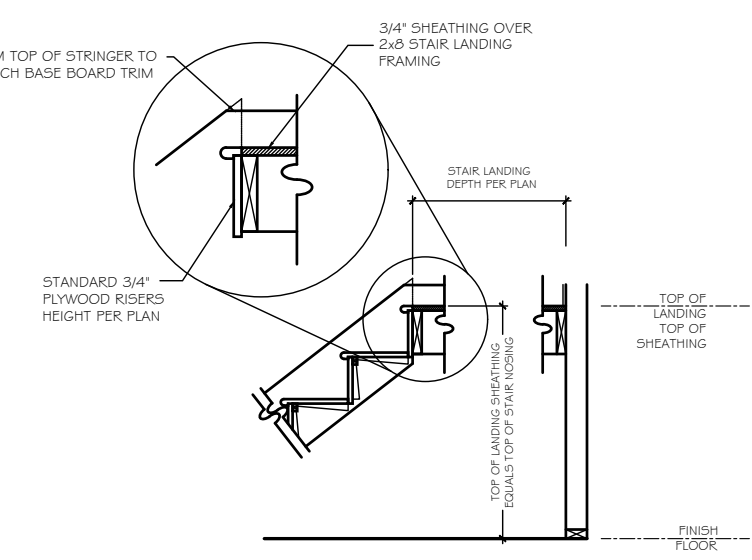

ST-27 STAIR SECTION - CARPET STAIRS AND LANDING

ST-28 EXTERIOR WALL FRAMING @ U-SHAPED STAIRS in BALLOON FRAMING

TrueHomes
 IT'S ALL ABOUT U
 2649 Breckridge Centre Dr.
 Suite 104
 Monroe, N.C. 28110
 704-271-1191

WALKER GROVE
 LOT# 13

JASPER
 2304
 HARNETT

Copyright True Homes L.L.C. All rights reserved. The duplication, reproduction, copying, sale, rental, licensing, or any other distribution or use of these drawings, any portion thereof, or the plans depicted hereon is strictly prohibited.
 PREPARED BY:
 SARAH
 DATE:
 6-23-21
 SCALE:
 AS SHOWN
 REVIEWED BY:
 PETER

SHEET:
D5.3

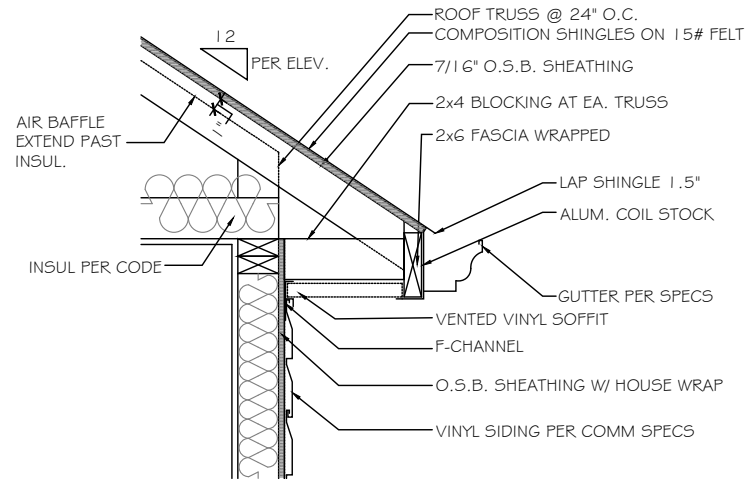

A CORNICE DETAIL - VINYL/VINYL
SCALE: NOT TO SCALE SIDES & REAR

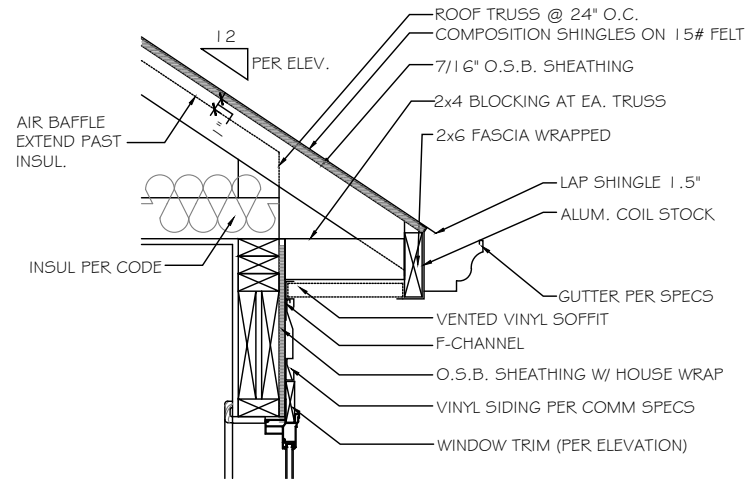

B CORNICE DETAIL - VINYL/VINYL
SCALE: NOT TO SCALE OVER WINDOW

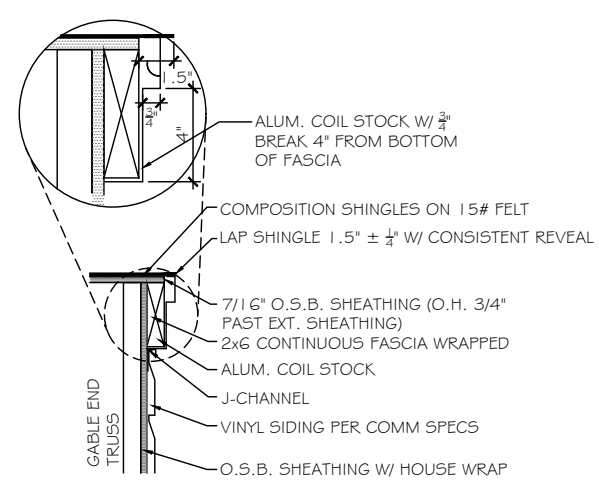

C FLUSH RAKE DETAIL - VINYL/VINYL
SCALE: NOT TO SCALE GABLE END

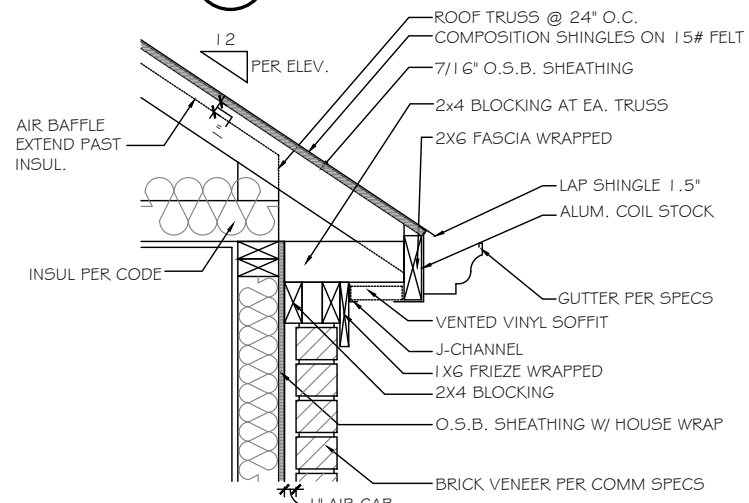

D BRICK CORNICE DETAIL - VINYL/VINYL
SCALE: NOT TO SCALE FRONT

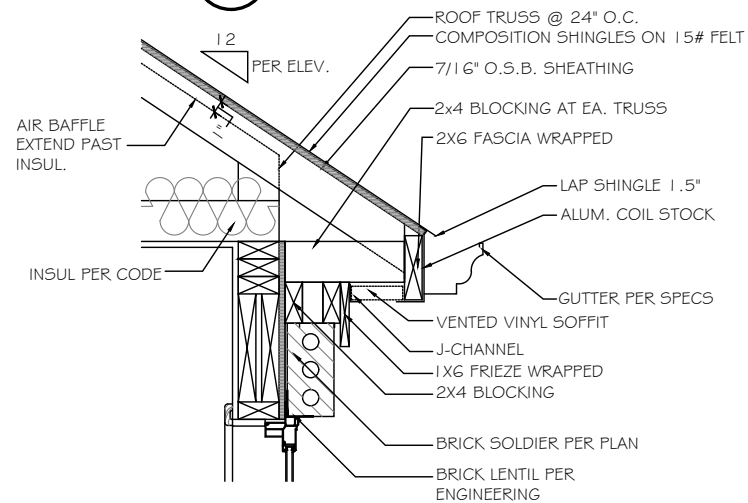

E BRICK CORNICE DETAIL - VINYL/VINYL
SCALE: NOT TO SCALE OVER WINDOW

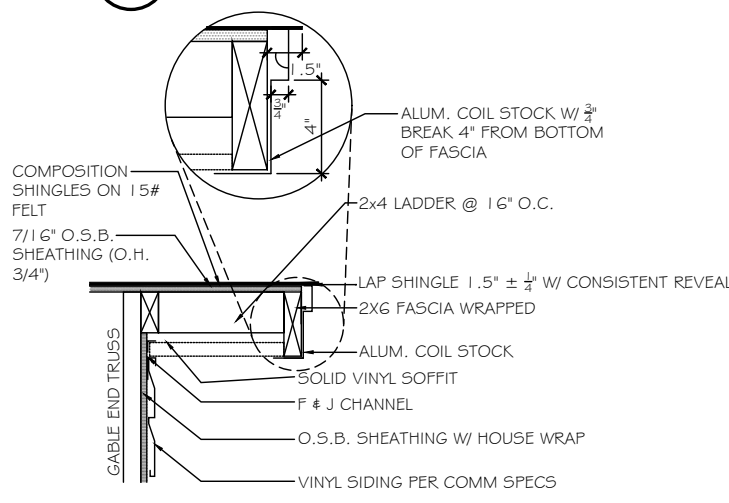

F RAKE OVERHANG DETAIL - VINYL/VINYL
SCALE: NOT TO SCALE GABLE END SIDE

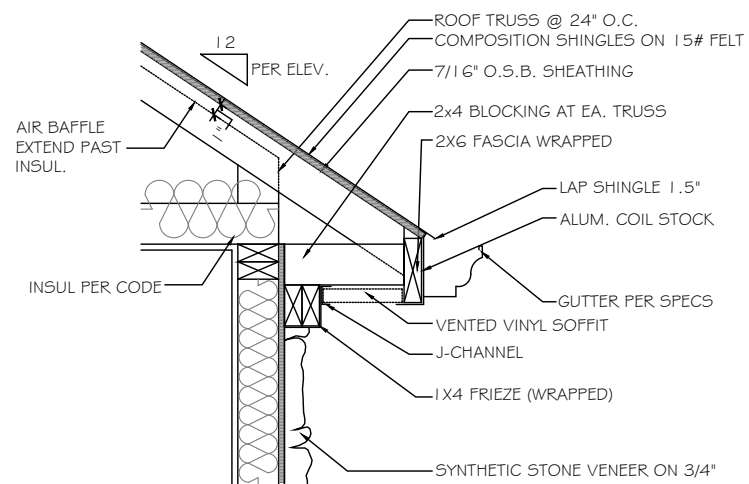

G STONE CORNICE DETAIL - VINYL/VINYL
SCALE: NOT TO SCALE FRONT & REAR

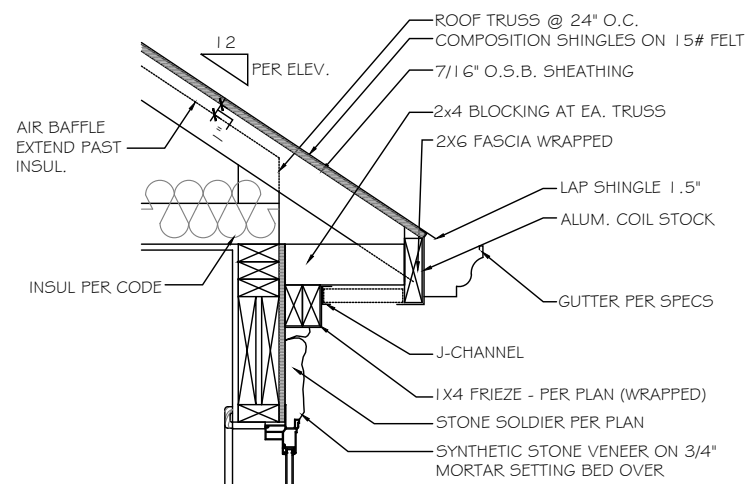

H STONE CORNICE DETAIL - VINYL/VINYL
SCALE: NOT TO SCALE OVER WINDOW

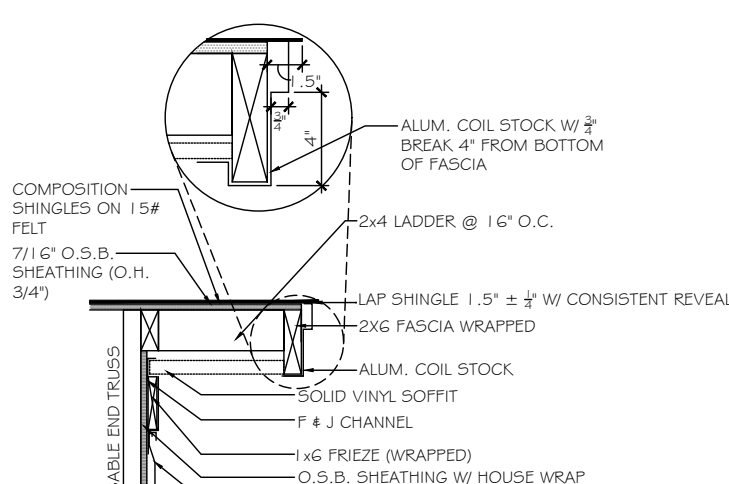

J RAKE OVERHANG DETAIL w/ FRIEZE - VINYL/VINYL
SCALE: NOT TO SCALE FRONT

TrueHomes
IT'S ALL ABOUT U
2649 Breckridge Centre Dr.
Suite 104
Monroe, N.C. 28110
704-271-1191

WALKER GROVE
LOT# 13

JASPER
2304

HARNETT

Copyright True Homes L.L.C. All rights reserved. The duplication, reproduction, copying, sale, rental, licensing, or any other distribution or use of these drawings, any portion thereof, or the plans depicted hereon is strictly prohibited.
PREPARED BY:
SARAH
DATE:
6-23-21
SCALE:
AS SHOWN
REVIEWED BY:
PETER

SHEET:
D9

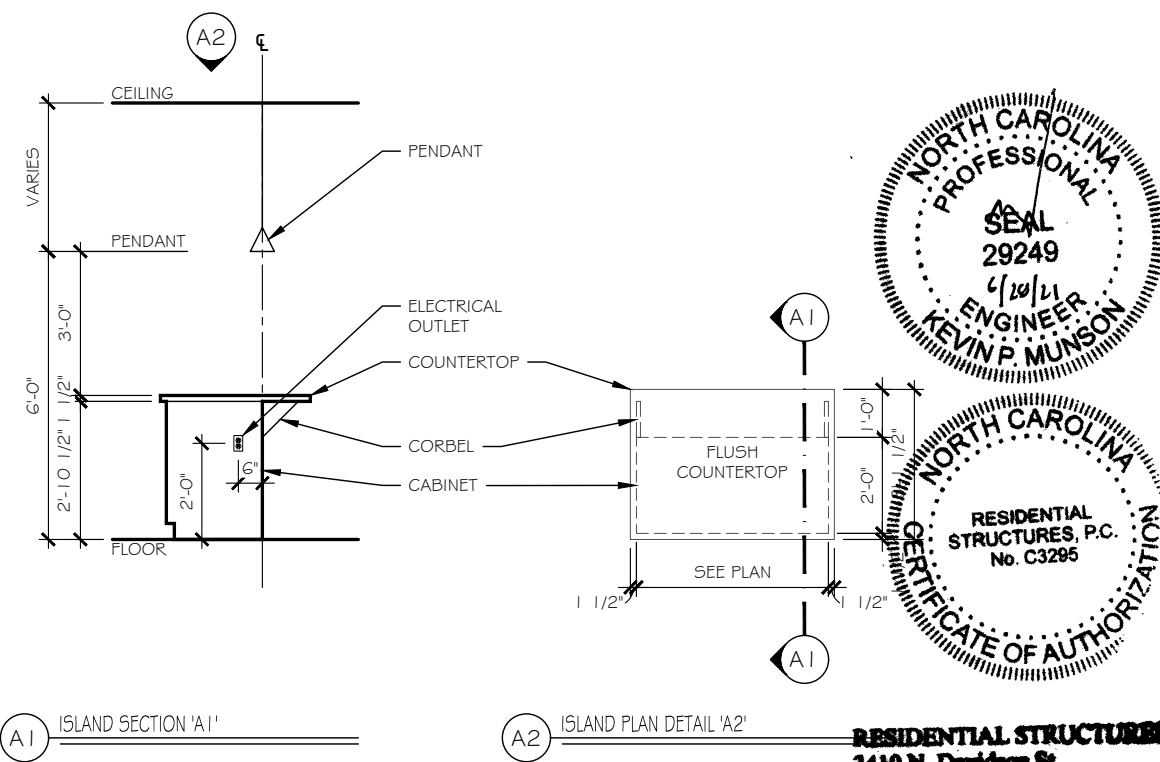

A1 ISLAND SECTION 'A1' **A2** ISLAND PLAN DETAIL 'A2'

A KITCHEN ISLAND DETAILS - FLUSH COUNTERTOP w/ CABINET ONLY

RESIDENTIAL STRUCTURES, INC.
 3410 N. Davidson St.
 Charlotte, N.C. 28205
 Seal For Structural Only

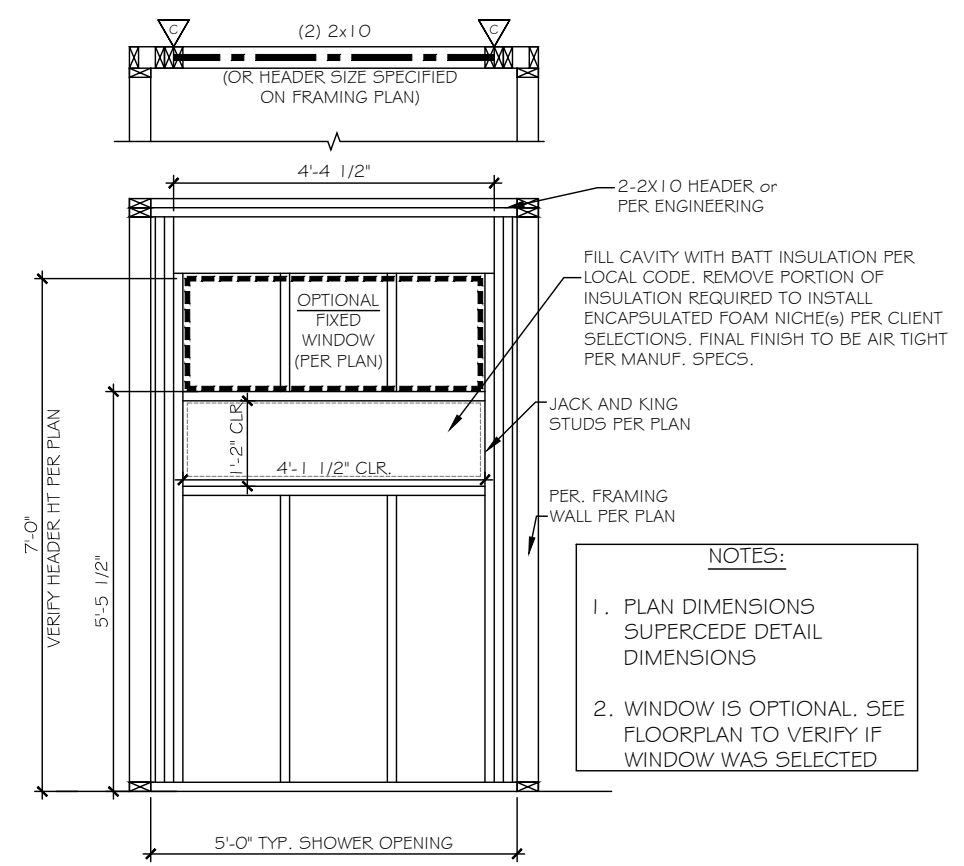

C TILE WALL NICHE DETAIL

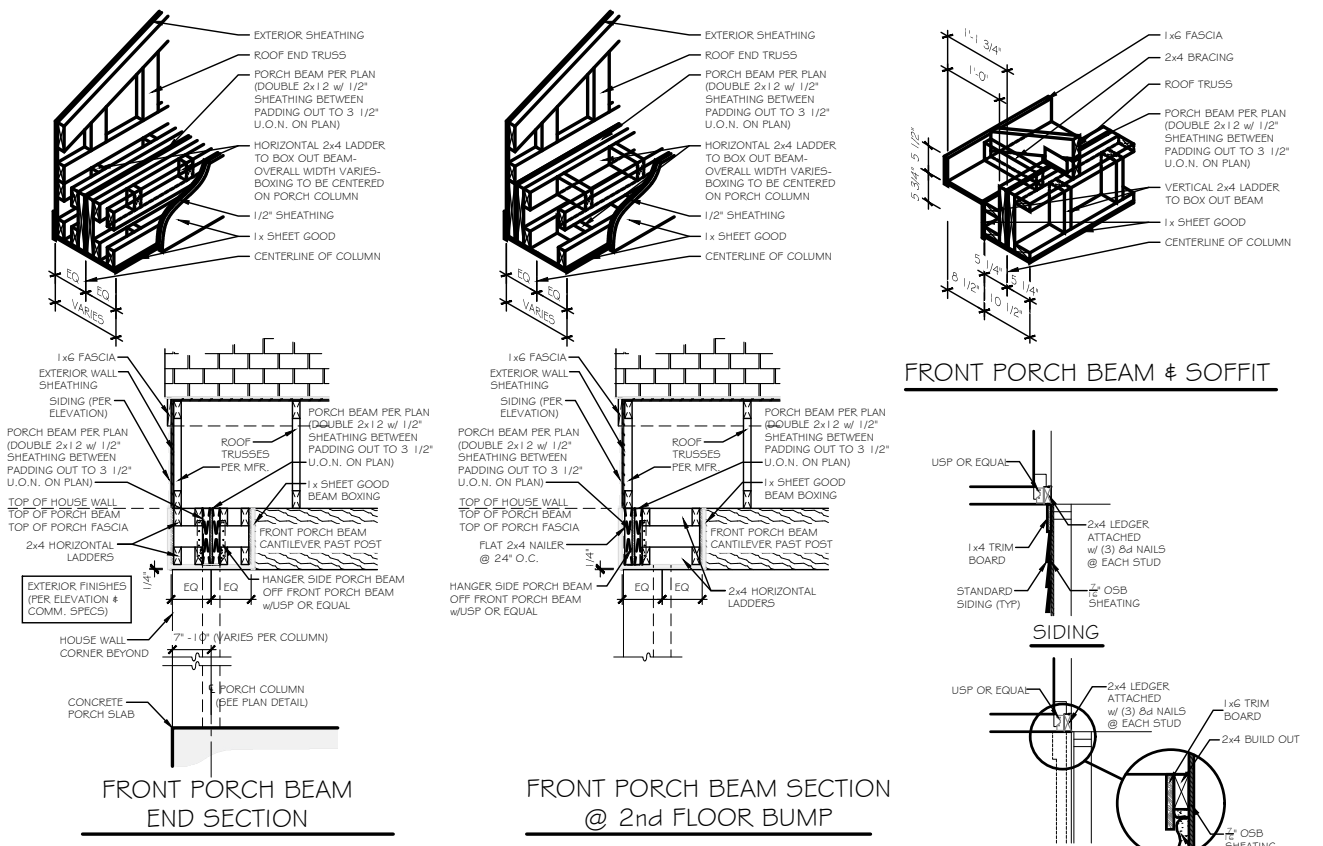

FRONT PORCH BEAM END SECTION **FRONT PORCH BEAM SECTION @ 2nd FLOOR BUMP**

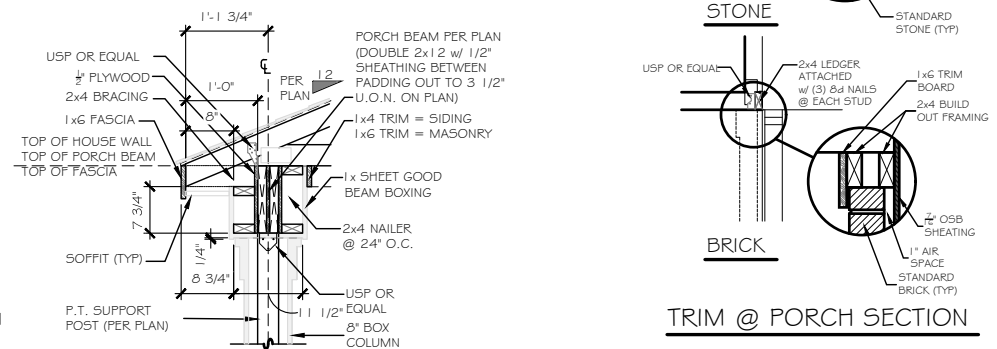

TRIM @ PORCH SECTION

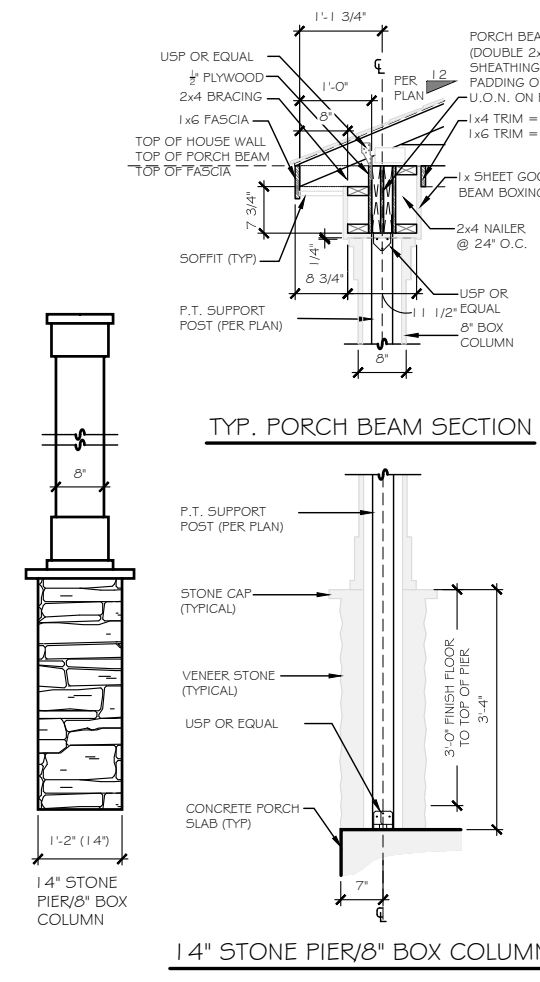

B FRONT PORCH COLUMN DETAIL

NOTE: PLAN DIMENSIONS SUPERCEDE DETAIL DIMENSIONS

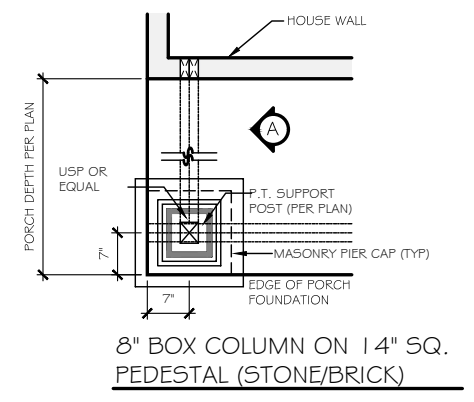

8" BOX COLUMN ON 14" SQ. PEDESTAL (STONE/BRICK)

TrueHomes
 IT'S ALL ABOUT U
 2649 Breckridge Centre Dr.
 Suite 104
 Monroe, N.C. 28110
 704-271-1191

WALKER GROVE

LOT# 13

JASPER 2304

HARNETT

Copyright True Homes L.L.C. All rights reserved. The duplication, reproduction, copying, sale, rental, licensing, or any other distribution or use of these drawings, any portion thereof, or the plans depicted hereon is strictly prohibited.

PREPARED BY:
SARAH

DATE:
 6-23-21

SCALE:
 AS SHOWN

REVIEWED BY:
PETER

SHEET:
D10