

Academy at Anderson Creek 1113 - 187 Scholar Drive, Spring Lake,  
28390 Harnett County  
Created: 4/5/2021

House Plan: Paxton III  
Elevation: A  
Stone/Brick Option: Option #1 see MSS Foundation: Crawl  
Foundation Finish: 3 Sides Parged  
Garage Hand: Right  
Garage: 2 Car Front  
Garage Door: (2) 8x8  
Front Porch: Concrete  
Roof: Truss  
Siding: Fiber Cement  
Ceiling Height 1st Floor: 9'  
Ceiling Height 2nd Floor: 9'  
Door Frame Height 1st Floor: 83"  
Door Frame Height 2nd Floor: 83"  
Windows 1st Floor: 6/0 Front only, 5/0 side&rear  
Windows 2nd Floor: 5/0

**OPTIONS**  
10 ft. Depth Screen Porch  
Study in Lieu of Bedroom #5  
Rec Room  
Trey Ceiling in Master Bedroom

Total Heated SQ FT: 3026  
Total Unheated SQ FT: 672  
Total SQ FT: 3698

Bedrooms:4+ Rec Room+ Study  
Full Bathrooms: 3  
Half Bathrooms: 0



THIS PLAN CONFORMS TO THE 2018 EDITION OF THE  
I.R.C. / NORTH CAROLINA RESIDENTIAL CODE.

**FRONT ELEVATION "C"**  
SCALE: -----1/8" = 1'-0"  
STONE OPTION #2

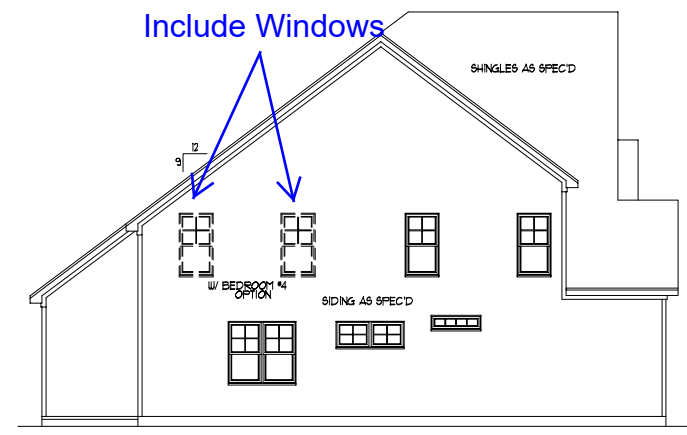

**LEFT SIDE ELEVATION**  
SCALE: -----1/16" = 1'-0"

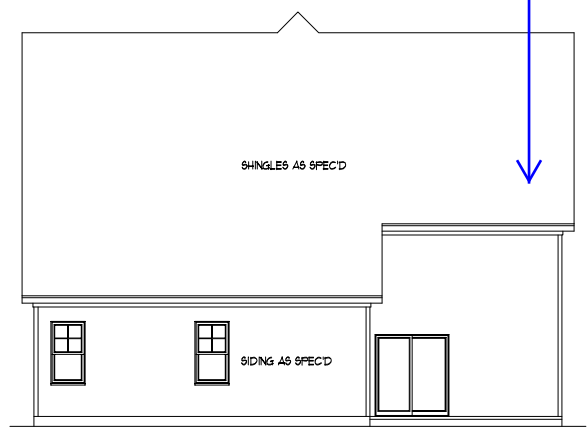

**REAR ELEVATION**  
SCALE: -----1/16" = 1'-0"

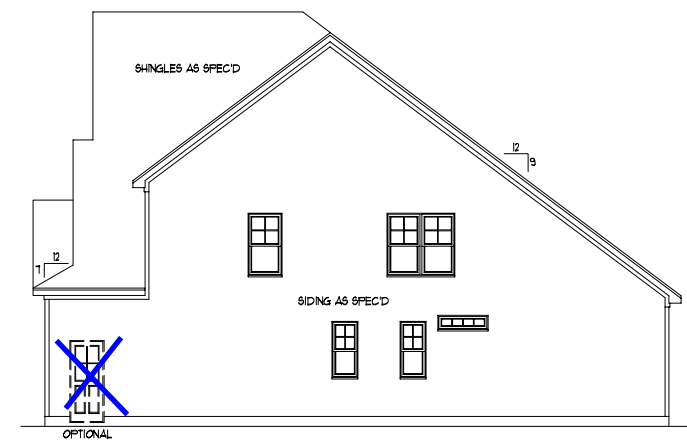

**RIGHT SIDE ELEVATION**  
SCALE: -----1/16" = 1'-0"

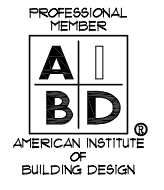

**DYNAMIC DESIGN GROUP, INC**  
David D Grorud  
(919) 601-1406  
DynamicDesignGroup@gmail.com

The drawings and specifications (plans) contained on these pages are the property of Dynamic Design Group and are offered to the named client or contractor for a conditional one time use. The conditional use is limited to the lot and subdivision specified herein, and only for said location. COPYRIGHT 2021  
Contractor shall verify all conditions and dimensions prior to construction. Any error or omissions shall be reported to Dynamic Design Group for corrections or justification. Once construction has commenced, the contractor shall assume all responsibility. Dimensions govern over scale, code governs over dimensions.

CAPITOL  
PROJECT FOR: CITY HOMES  
LOCATION: MULTI  
LOT: MULTI  
SUBDIVISION: MULTI  
COUNTY: MULTI

**PAXTON III**  
PLAN NAME  
**B-2379-44GR**  
PLAN I.D.  
**2-2-21**  
DATE

**A-1C**  
SHEET

The drawings and specifications (plans) contained on these pages are the property of Dynamic Design Group and are offered to the named client or contractor for a conditional one time use. The conditional use is limited to the lot and subdivision specified herein, and only for said location. COPYRIGHT 2021  
 Contractor shall verify all conditions and dimensions prior to construction. Any error or omissions shall be reported to Dynamic Design Group for corrections or justification. Once construction has commenced, the contractor shall assume all responsibility. Dimensions govern over scale, code governs over dimensions.

CAPITOL  
 PROJECT FOR: CITY HOMES  
 LOCATION: MULTI  
 LOT: MULTI  
 SUBDIVISION: MULTI  
 COUNTY: MULTI

**PAXTON III**  
 PLAN NAME  
**B-2379-44GR** 2-2-21  
 PLAN I.D. DATE

**A-2**  
 SHEET

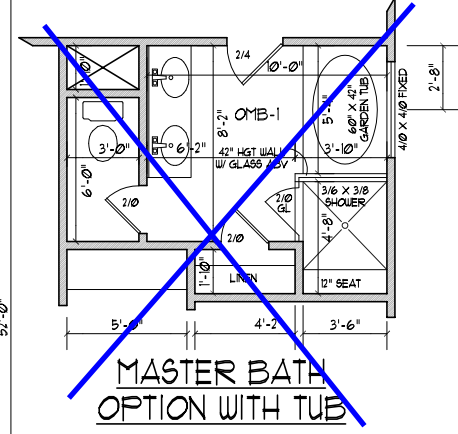
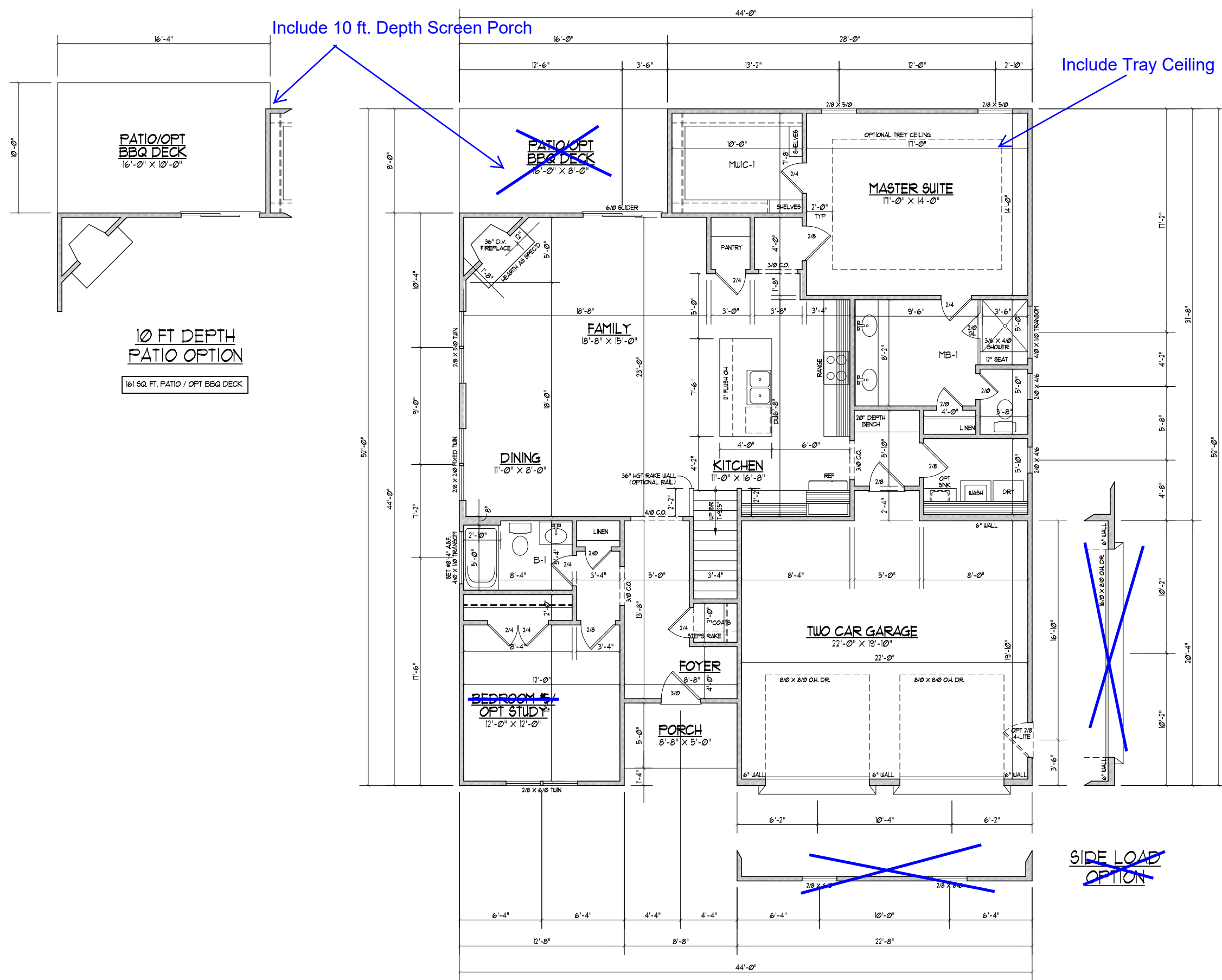

**FIRST FLOOR PLAN**  
 SCALE: ----- 1/8" = 1'-0"

1512 HEATED SQ. FT.  
 468 SQ. FT. GARAGE  
 43 SQ. FT. COVERED PORCH  
 128 SQ. FT. PATIO / OPT BBQ DECK

- NOTES:
- 9'-0" CLG. HGT. (9' - 1 1/2" FLT. HGT.) UNLESS OTHERWISE NOTED.
  - ALL WALLS DRAIN AT 4" WIDTHS
  - SET WINDOWS AT 1'-10" A.S.F. UNLESS OTHERWISE NOTED.
  - DIMENSIONS ARE TO FRAMING UNLESS OTHERWISE NOTED.
  - CONSULT WINDOW MANUFACTURER'S SPECS. FOR EGRESS REQUIREMENTS, PRESSURE RATINGS, & ROUGH OPENINGS.
  - ELECTRICAL LAYOUT BY BUILDER

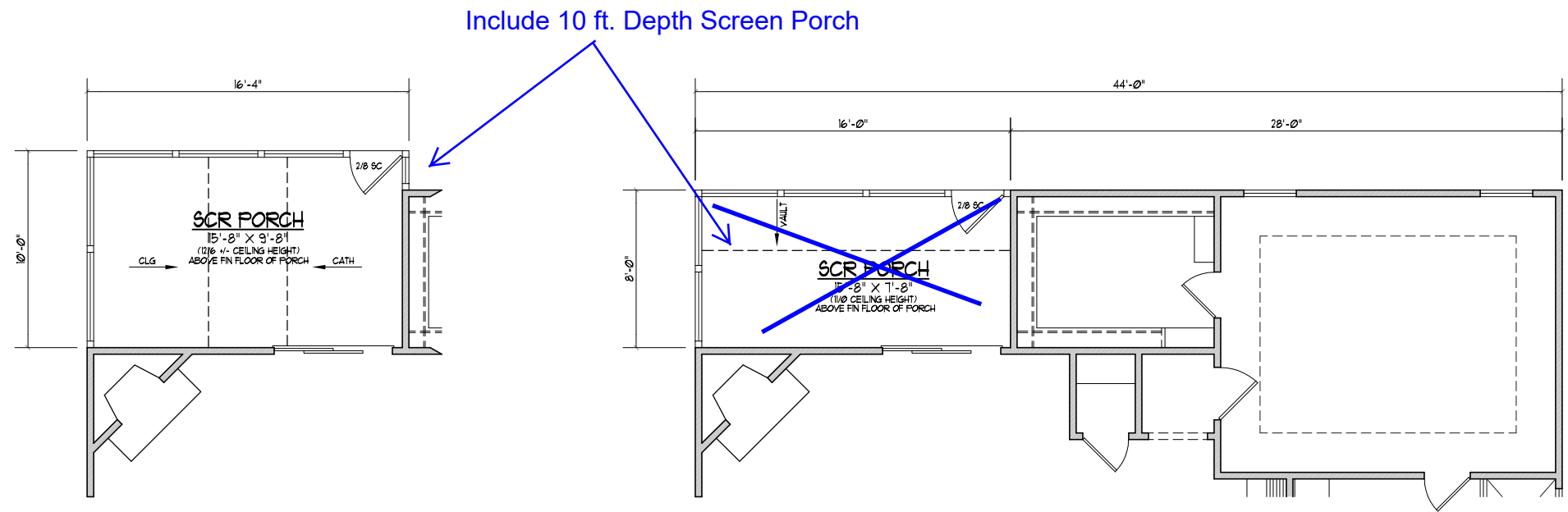

**10 FT DEPTH SCREEN PORCH OPTION**  
 SCALE: ----- 1/8" = 1'-0"  
 161 SQ. FT. SCREEN PORCH

**SCREEN PORCH**  
 SCALE: ----- 1/8" = 1'-0"  
 128 SQ. FT. SCREEN PORCH

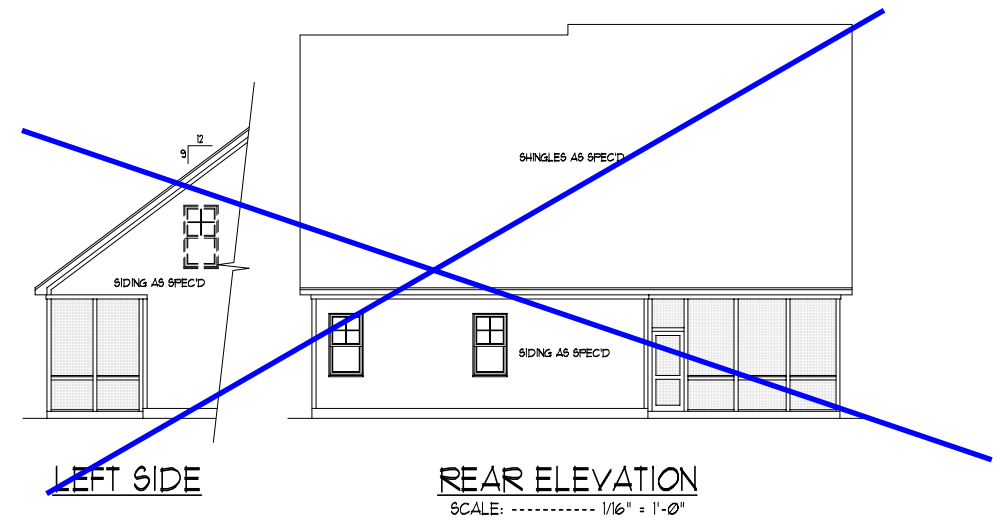

**LEFT SIDE**

**REAR ELEVATION**  
 SCALE: ----- 1/16" = 1'-0"

Include 10 ft. Depth Screen Porch →



**LEFT SIDE**

**REAR ELEVATION**  
 SCALE: ----- 1/16" = 1'-0"

**RIGHT SIDE**

**SCREEN PORCH OPTIONS**

CAPITOL  
 PROJECT FOR: CITY HOMES  
 LOCATION: MULTI  
 LOT: MULTI  
 SUBDIVISION: MULTI  
 COUNTY: MULTI

**PAXTON III**  
 PLAN NAME  
**B-2379-44GR**  
 PLAN I.D.  
**2-2-21**  
 DATE

**A-2** SCREEN PORCH OPTIONS  
 SHEET

The drawings and specifications (plans) contained on these pages are the property of Dynamic Design Group and are offered to the named client or contractor for a conditional one time use. The conditional use is limited to the lot and subdivision specified herein, and only for said location. COPYRIGHT 2021  
 Contractor shall verify all conditions and dimensions prior to construction. Any error or omissions shall be reported to Dynamic Design Group for corrections or justification. Once construction has commenced, the contractor shall assume all responsibility. Dimensions govern over scale, code governs over dimensions.

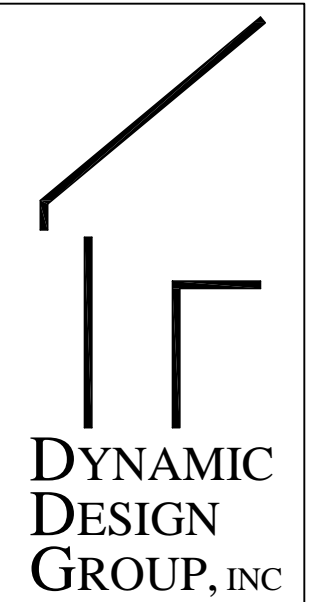

**DYNAMIC DESIGN GROUP, INC**  
 David D Grorud  
 (919) 601-1406  
 DynamicDesignGroup@gmail.com

The drawings and specifications (plans) contained on these pages are the property of Dynamic Design Group and are offered to the named client or contractor for a conditional one time use. The conditional use is limited to the lot and subdivision specified herein, and only for said location. COPYRIGHT 2021  
 Contractor shall verify all conditions and dimensions prior to construction. Any error or omissions shall be reported to Dynamic Design Group for corrections or justification. Once construction has commenced, the contractor shall assume all responsibility. Dimensions govern over scale, code governs over dimensions.

CAPITOL  
 PROJECT FOR: CITY HOMES  
 LOCATION: MULTI  
 LOT: MULTI  
 SUBDIVISION: MULTI  
 COUNTY: MULTI

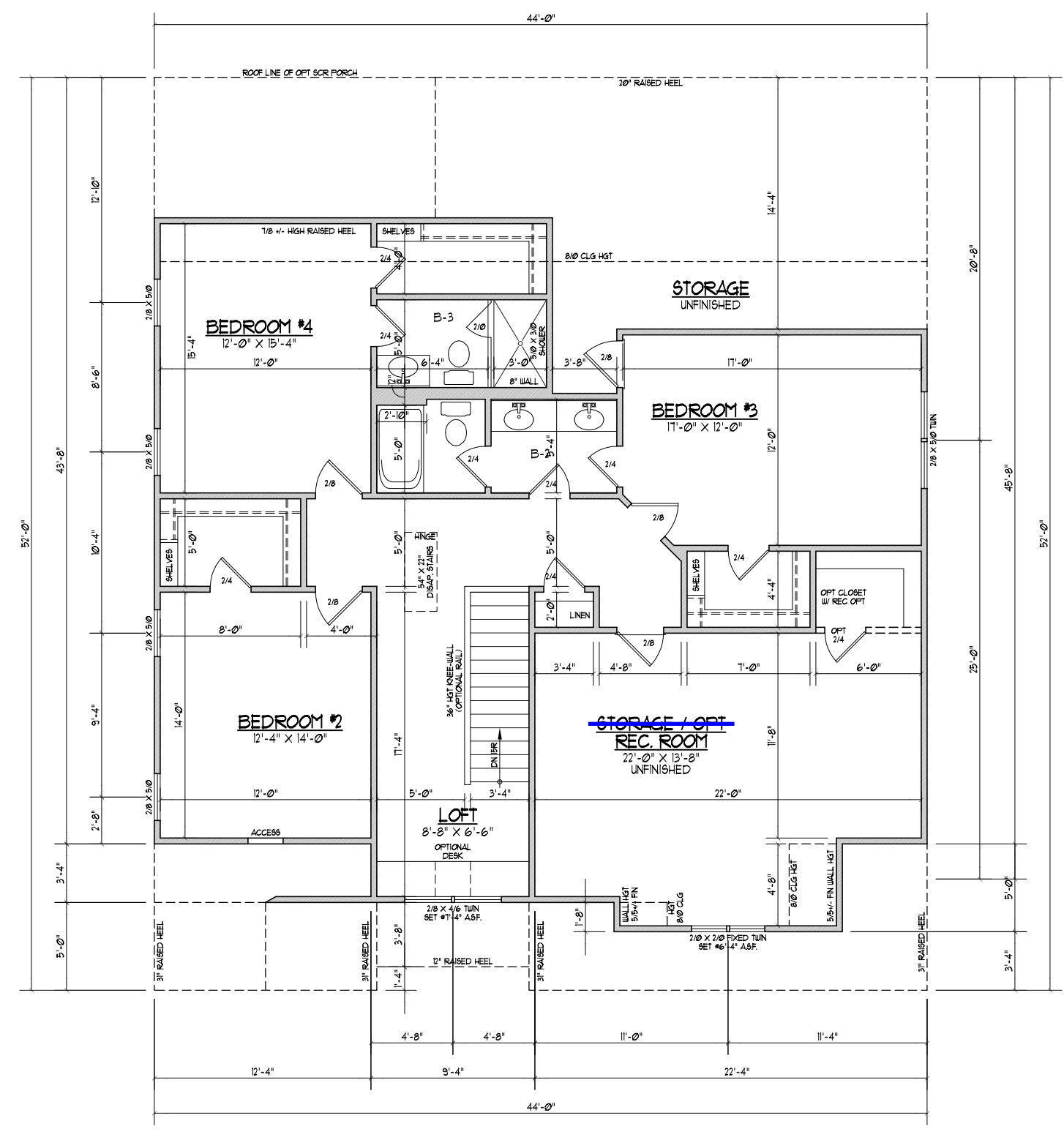

← Include Rec Room

ELEVATION "C"  
 SECOND FLOOR PLAN  
 W/ BEDROOM #4 / BATH OPTION  
 SCALE ----- 1/8"=1'-0"

1091 HEATED SQ. FT.  
 378 UNFIN. STORAGE/OPT REC RM SQ. FT.

- NOTES:
- 1) 0'-0" CLG. HGT. (8' - 1 1/2" FLT. HGT.) UNLESS OTHERWISE NOTED.
  - 2) ALL WALLS DRAWN AT 4" WIDTHS UNLESS OTHERWISE NOTED.
  - 3) SET WINDOWS AT 6'-8" A.S.F. UNLESS OTHERWISE NOTED.
  - 4) DIMENSIONS ARE TO FRAMING UNLESS OTHERWISE NOTED.
  - 5) CONSULT WINDOW MANUFACTURER'S SPECS. FOR EGRESS REQUIREMENTS, PRESSURE RATINGS, & ROUGH OPNG'S.

**PAXTON III**  
 PLAN NAME  
**B-2379-44GR** 2-2-21  
 PLAN I.D. DATE  
**A-3C**  
 SHEET

**OPTIONAL ELECTRICAL ITEMS**  
 WITH ALL LIGHTS LISTED RESPECTIVE SWITCHES ARE ASSUMED

RECESSED LIGHTS
FLUORESCENT LIGHT IN LIEU OF RECESSED CANS @ KITCHEN ONLY
CEILING FANS IN LIEU OF FLUSH MOUNT
FLOODLIGHTS
HANGING LIGHTS @ KITCHEN
UNDER CABINET LIGHTS
EXTERIOR LIGHTS AT GARAGE DOOR

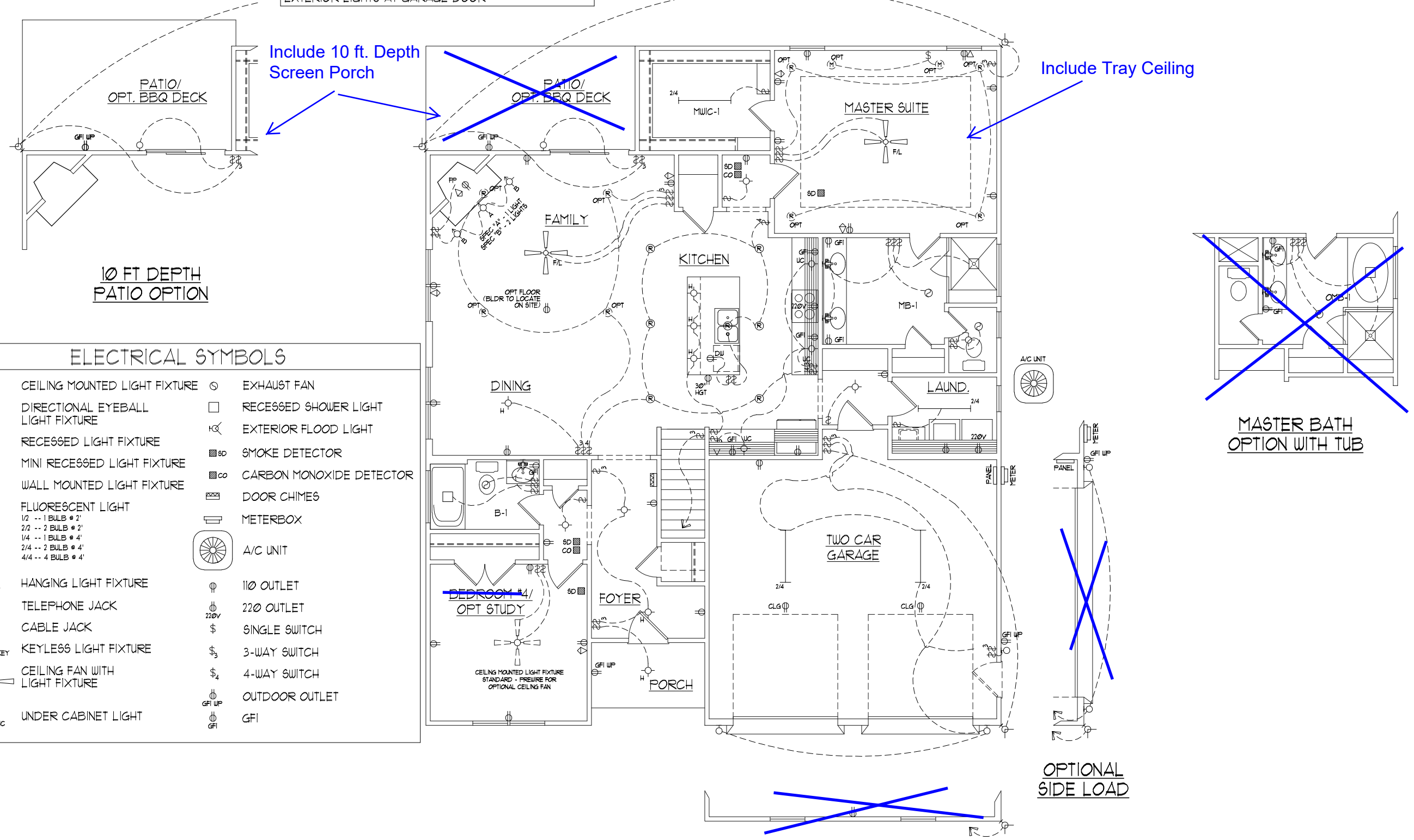

**10 FT DEPTH PATIO OPTION**

**ELECTRICAL SYMBOLS**

⊙	CEILING MOUNTED LIGHT FIXTURE	⊙	EXHAUST FAN
⊙	DIRECTIONAL EYEBALL LIGHT FIXTURE	□	RECESSED SHOWER LIGHT
⊙	RECESSED LIGHT FIXTURE	⊙	EXTERIOR FLOOD LIGHT
⊙	MINI RECESSED LIGHT FIXTURE	SD	SMOKE DETECTOR
⊙	WALL MOUNTED LIGHT FIXTURE	CO	CARBON MONOXIDE DETECTOR
I	FLUORESCENT LIGHT 1/2 -- 1 BULB @ 2' 2/2 -- 2 BULB @ 2' 1/4 -- 1 BULB @ 4' 2/4 -- 2 BULB @ 4' 4/4 -- 4 BULB @ 4'	DC	DOOR CHIMES
⊙	HANGING LIGHT FIXTURE	M	METERBOX
▷	TELEPHONE JACK	⊙	A/C UNIT
◁	CABLE JACK	⊙	110 OUTLET
⊙	KEYLESS LIGHT FIXTURE	⊙	220 OUTLET
⊙	CEILING FAN WITH LIGHT FIXTURE	\$	SINGLE SWITCH
⊙	UNDER CABINET LIGHT	\$	3-WAY SWITCH
		\$	4-WAY SWITCH
		⊙	OUTDOOR OUTLET
		⊙	GFI

**FIRST FLOOR ELECTRICAL LAYOUT**

**DYNAMIC DESIGN GROUP, INC**  
 David D Grorud  
 (919) 601-1406  
 DynamicDesignGroup@gmail.com

The drawings and specifications (plans) contained on these pages are the property of Dynamic Design Group and are offered to the named client or contractor for a conditional one time use. The conditional use is limited to the lot and subdivision specified herein, and only for said location. COPYRIGHT 2021

Contractor shall verify all conditions and dimensions prior to construction. Any error or omissions shall be reported to Dynamic Design Group for corrections or justification. Once construction has commenced, the contractor shall assume all responsibility. Dimensions govern over scale, code governs over dimensions.

PROJECT FOR: CAPITOL CITY HOMES  
 LOCATION: MULTI  
 LOT: MULTI  
 SUBDIVISION: MULTI  
 COUNTY: MULTI

**PAXTON III**  
 PLAN NAME  
**B-2379-44GR** 2-2-21 DATE  
 PLAN I.D.

**E-1**  
 SHEET

The drawings and specifications (plans) contained on these pages are the property of Dynamic Design Group and are offered to the named client or contractor for a conditional one time use. The conditional use is limited to the lot and subdivision specified herein, and only for said location. COPYRIGHT 2021  
 Contractor shall verify all conditions and dimensions prior to construction. Any error or omissions shall be reported to Dynamic Design Group for corrections or justification. Once construction has commenced, the contractor shall assume all responsibility. Dimensions govern over scale, code governs over dimensions.

CAPITOL  
 PROJECT FOR: CITY HOMES  
 LOCATION: MULTI  
 LOT: MULTI  
 SUBDIVISION: MULTI  
 COUNTY: MULTI

**PAXTON III**  
 PLAN NAME  
**B-2379-44GR** 2-2-21  
 PLAN I.D. DATE

**E-1** SCREEN PORCH OPTIONS  
 SHEET

Include 10 ft. Depth Screen Porch

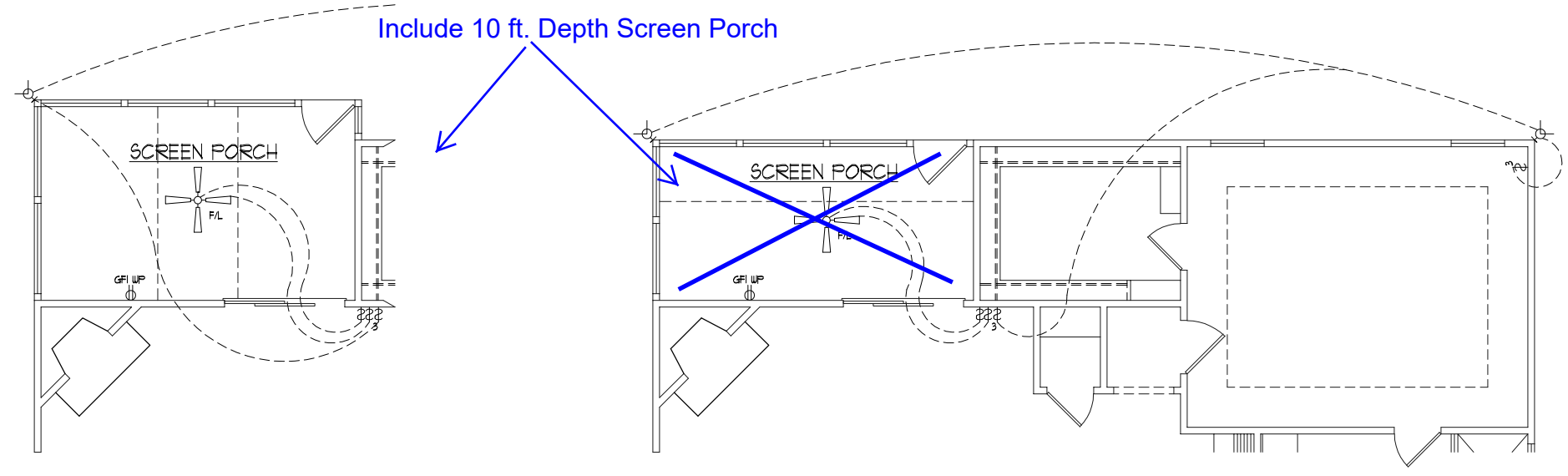

10 FT DEPTH SCREEN PORCH OPTION

8 FT DEPTH SCREEN PORCH OPTION

**ELECTRICAL SYMBOLS**

	CEILING MOUNTED LIGHT FIXTURE		EXHAUST FAN
	DIRECTIONAL EYEBALL LIGHT FIXTURE		RECESSED SHOWER LIGHT
	RECESSED LIGHT FIXTURE		EXTERIOR FLOOD LIGHT
	MINI RECESSED LIGHT FIXTURE		SMOKE DETECTOR
	WALL MOUNTED LIGHT FIXTURE		CARBON MONOXIDE DETECTOR
	FLUORESCENT LIGHT		DOOR CHIMES
1/2 -- 1 BULB @ 2'			METERBOX
2/2 -- 2 BULB @ 2'			A/C UNIT
1/4 -- 1 BULB @ 4'			110 OUTLET
2/4 -- 2 BULB @ 4'			220 OUTLET
4/4 -- 4 BULB @ 4'			SINGLE SWITCH
	HANGING LIGHT FIXTURE		3-WAY SWITCH
	TELEPHONE JACK		4-WAY SWITCH
	CABLE JACK		OUTDOOR OUTLET
	KEYLESS LIGHT FIXTURE		GFI
	CEILING FAN WITH LIGHT FIXTURE		
	UNDER CABINET LIGHT		

OPTIONAL SCREEN PORCHES



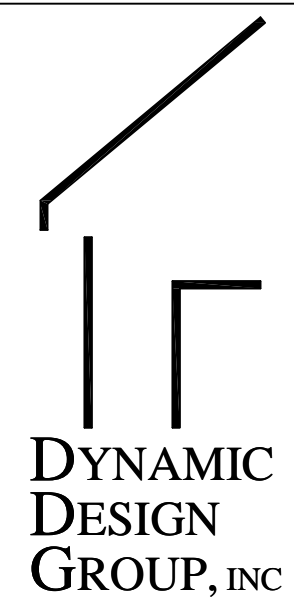

David D Grorud  
 (919) 601-1406  
 DynamicDesignGroup@gmail.com

The drawings and specifications (plans) contained on these pages are the property of Dynamic Design Group and are offered to the named client or contractor for a conditional one time use. The conditional use is limited to the lot and subdivision specified herein, and only for said location. COPYRIGHT 2021  
 Contractor shall verify all conditions and dimensions prior to construction. Any error or omissions shall be reported to Dynamic Design Group for corrections or justification. Once construction has commenced, the contractor shall assume all responsibility. Dimensions govern over scale, code governs over dimensions.

CAPITOL  
 PROJECT FOR: CITY HOMES  
 LOCATION: MULTI  
 LOT: MULTI  
 SUBDIVISION: MULTI  
 COUNTY: MULTI

**PAXTON III**  
 PLAN NAME  
**B-2379-44GR** 2-2-21  
 PLAN I.D. DATE

**E-2**  
 SHEET

Include 10 ft. Depth Screen Porch

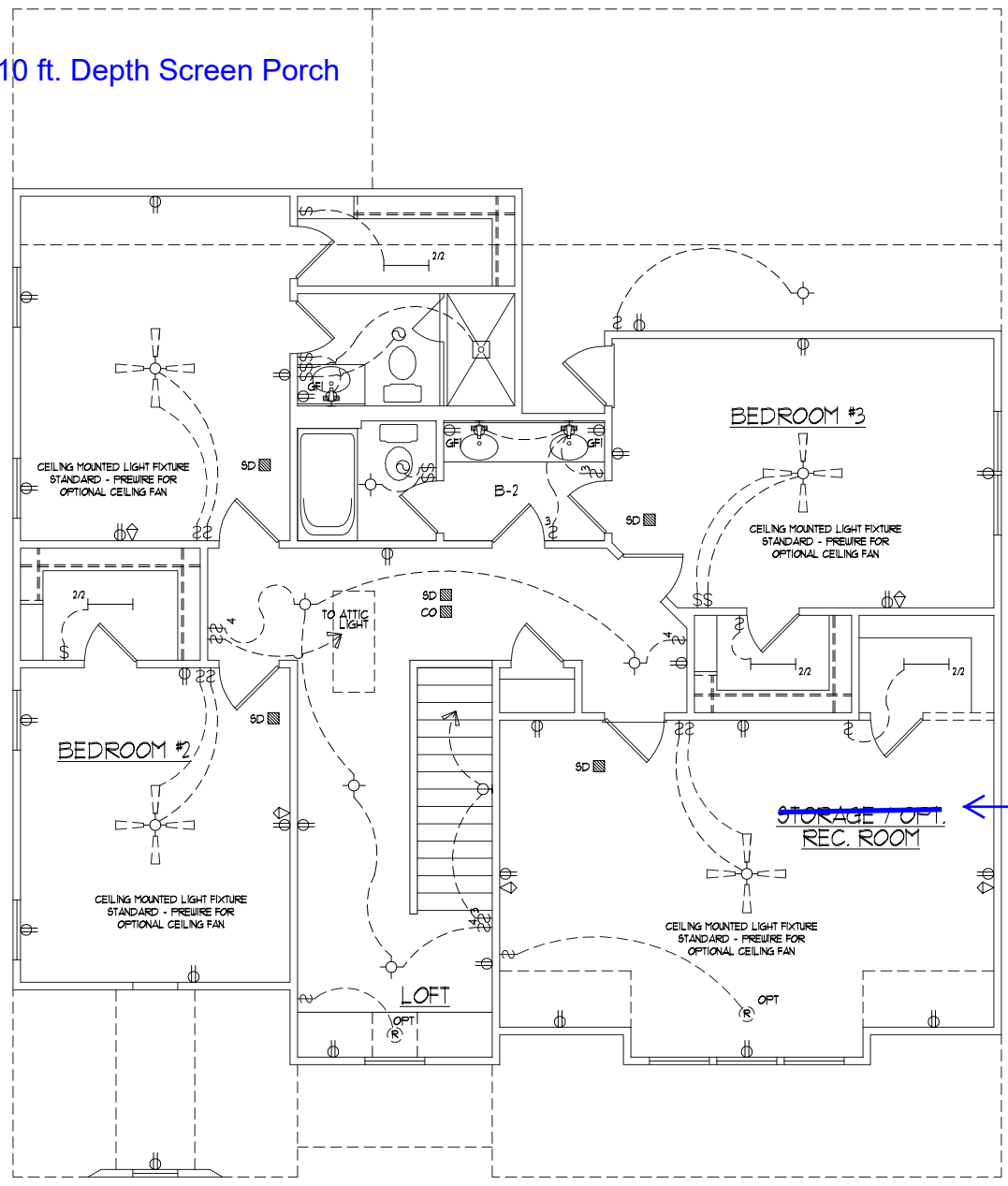

ELEVATION "A"

ELECTRICAL SYMBOLS

- ⊕ CEILING MOUNTED LIGHT FIXTURE
- ⊕ DIRECTIONAL EYEBALL LIGHT FIXTURE
- ⊗ RECESSED LIGHT FIXTURE
- ⊙ MINI RECESSED LIGHT FIXTURE
- ⊖ WALL MOUNTED LIGHT FIXTURE
- FLUORESCENT LIGHT  
 1/2 -- 1 BULB @ 2'  
 2/2 -- 2 BULB @ 2'  
 1/4 -- 1 BULB @ 4'  
 2/4 -- 2 BULB @ 4'  
 4/4 -- 4 BULB @ 4'
- ⊕ HANGING LIGHT FIXTURE
- ▷ TELEPHONE JACK
- ◁ CABLE JACK
- ⊕ KEY KEYLESS LIGHT FIXTURE
- ⊕ CEILING FAN WITH LIGHT FIXTURE
- ⊕ UC UNDER CABINET LIGHT
- ⊙ EXHAUST FAN
- RECESSED SHOWER LIGHT
- ⊕ EXTERIOR FLOOD LIGHT
- ⊕ SMOKE DETECTOR
- ⊕ CO CARBON MONOXIDE DETECTOR
- ⊕ DOOR CHIMES
- ⊕ METERBOX
- ⊕ A/C UNIT
- ⊕ 110 OUTLET
- ⊕ 220V 220 OUTLET
- \$ SINGLE SWITCH
- \$3 3-WAY SWITCH
- \$4 4-WAY SWITCH
- ⊕ OFI OUTDOOR OUTLET
- ⊕ GFI

Include Rec Room

SECOND FLOOR  
 ELECTRICAL LAYOUT  
 W/ BEDROOM #4 / BATH OPTION

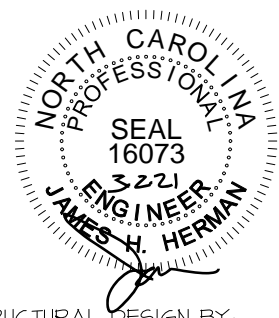

STRUCTURAL DESIGN BY:  
 SOUTHERN ENGINEERS, P.A.  
 3716 BENSON DRIVE RALEIGH, NC 27609  
 LICENSE: C-1287, PHONE: 919-878-1617  
 PROJECT #: 21-2316-GR

- Engineers seal applies only to structural components on this document. Seal does not include construction means, methods, techniques, sequences, procedures or safety precautions.
- Any deviations or discrepancies on plans are to be brought to the immediate attention of Southern Engineers. Failure to do so will void Southern Engineer's liability.
- Seal is valid for a project permitted within one year from date of seal.
- Use of these plans constitutes approval of terms and conditions as defined in the customer agreement.

REFER TO "SD" SHEET(S) FOR STANDARD DETAILS, BRACING DETAILS AND STRUCTURAL NOTES.

WALL VENTED CRAWL SPACE	
REQUIRED	
1637	SQ. FT. / 50 = 10.91 SQ. FT. OF VENTILATION

CLOSED CRAWL SPACE VENTILATION METHODS	
(SEE REFERENCED SECTIONS IN CODE BOOK FOR DETAILED INSTRUCTIONS)	
(R409.5.1) DEHUMIDIFIER	A PERMANENTLY INSTALLED DEHUMIDIFIER SHALL BE PROVIDED IN THE CRAWL SPACE WITH THE MINIMUM RATED CAPACITY OF 5 PINTS PER DAY.
(R409.5.2) SUPPLY AIR	1637 SQ. FT. / 30 = 56 CFM
(R409.5.3) HOUSE AIR	1637 SQ. FT. / 50 = 34 CFM
(R409.5.4) EXHAUST FAN	1637 SQ. FT. / 50 = 34 CFM
(R409.5.5) CONDITIONED SPACE	THE CRAWL SPACE SHALL BE DESIGNED AS A HEATED AND COOLED, CONDITIONED SPACE WITH WALL INSULATION INSTALLED AS PER THE REQUIREMENTS OF SECTION R409.5.1.

CRAWL SPACE FOUNDATION PLAN  
 W/ BEDROOM #4 / BATH OPTION  
 SCALE: 1/8"=1'-0"

NOTES:  
 1) SEE SHEET D-1 FOR DETAILS.  
 2) DIMENSIONS ARE TO EXTERIOR OF FOUNDATION.

Include 10 ft. Depth Screen Porch

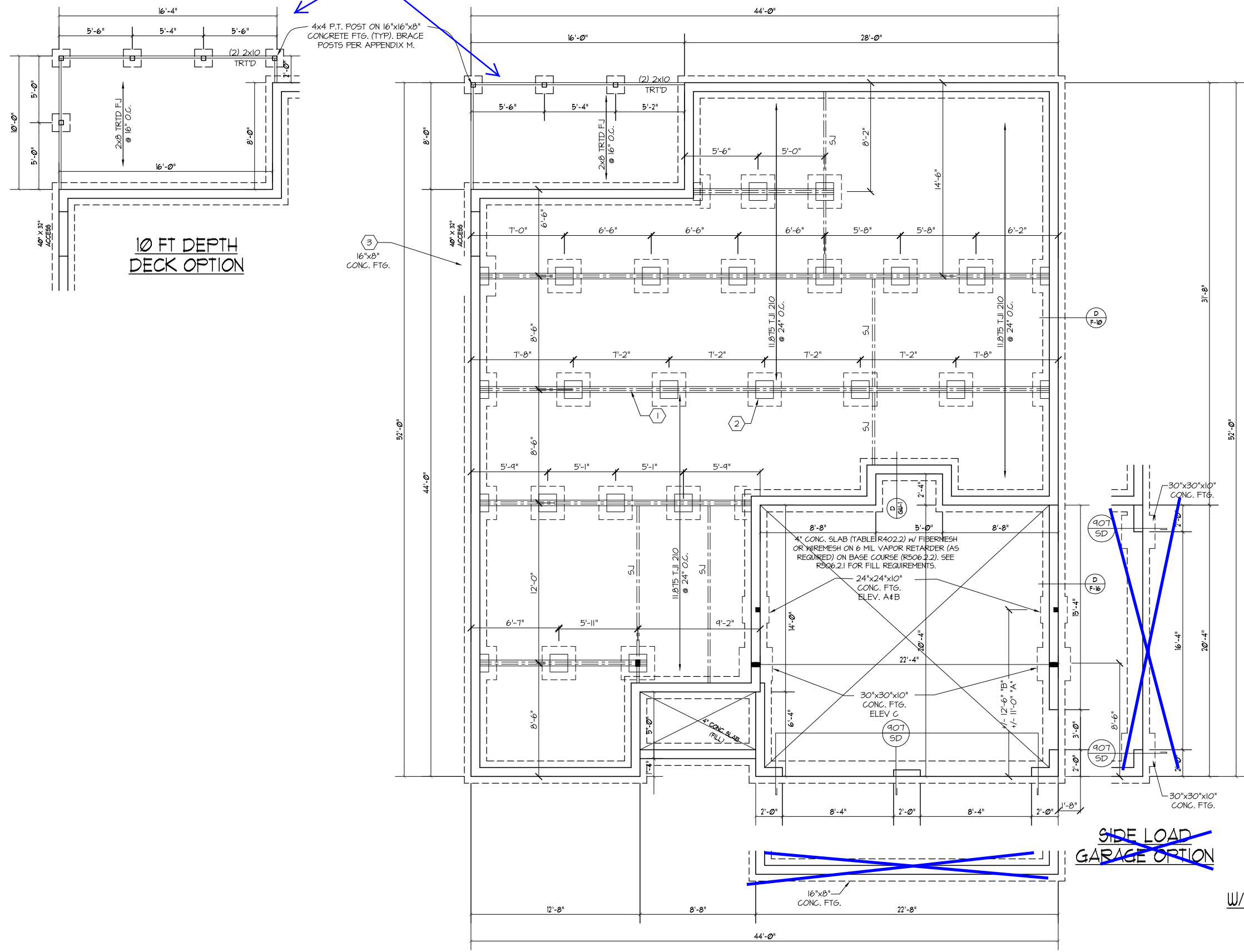

**DYNAMIC DESIGN GROUP, INC**  
 David D Grorud  
 (919) 601-1406  
 DynamicDesignGroup@gmail.com

The drawings and specifications (plans) contained on these pages are the property of Dynamic Design Group and are offered to the named client or contractor for a conditional one time use. The conditional use is limited to the lot and subdivision specified herein, and only for said location. COPYRIGHT 2021

Contractor shall verify all conditions and dimensions prior to construction. Any error or omissions shall be reported to Dynamic Design Group for corrections or justification. Once construction has commenced, the contractor shall assume all responsibility. Dimensions govern over scale, code governs over dimensions.

CAPITOL PROJECT FOR: CITY HOMES  
 LOCATION: MULTI  
 LOT: MULTI  
 SUBDIVISION: MULTI  
 COUNTY: MULTI

**PAXTON III**  
 PLAN NAME  
**B-2379-44GR**  
 PLAN I.D.  
**2-2-21**  
 DATE

**S-1**  
 SHEET



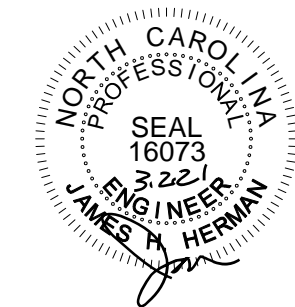

STRUCTURAL DESIGN BY:  
 SOUTHERN ENGINEERS, P.A.  
 3716 BENSON DRIVE RALEIGH, NC 27609  
 LICENSE: C-1287, PHONE: 919-878-1617  
 PROJECT #: 21-2316-GL

- Engineers seal applies only to structural components on this document. Seal does not include construction means, methods, techniques, sequences, procedures or safety precautions.
- Any deviations or discrepancies on plans are to be brought to the immediate attention of Southern Engineers. Failure to do so will void Southern Engineer's liability.
- Seal is valid for a project permitted within one year from date of seal.
- Use of these plans constitutes approval of terms and conditions as defined in the customer agreement.

REFER TO "SD" SHEET(S) FOR STANDARD DETAILS, BRACING DETAILS AND STRUCTURAL NOTES.

**DYNAMIC DESIGN GROUP, INC**  
 David D Grorud  
 (919) 601-1406  
 DynamicDesignGroup@gmail.com

The drawings and specifications (plans) contained on these pages are the property of Dynamic Design Group and are offered to the named client or contractor for a conditional one time use. The conditional use is limited to the lot and subdivision specified herein, and only for said location. COPYRIGHT 2021  
 Contractor shall verify all conditions and dimensions prior to construction. Any error or omissions shall be reported to Dynamic Design Group for corrections or justification. Once construction has commenced, the contractor shall assume all responsibility. Dimensions govern over scale, code governs over dimensions.

CAPITOL PROJECT FOR: CITY HOMES  
 LOCATION: MULTI  
 LOT: MULTI  
 SUBDIVISION: MULTI  
 COUNTY: MULTI

**PAXTON III**  
 PLAN NAME  
**B-2379-44GR**  
 PLAN I.D.  
 2-2-21  
 DATE

**S-1** SCREEN PORCH OPTIONS SHEET

Include 10 ft. Depth Screen Porch

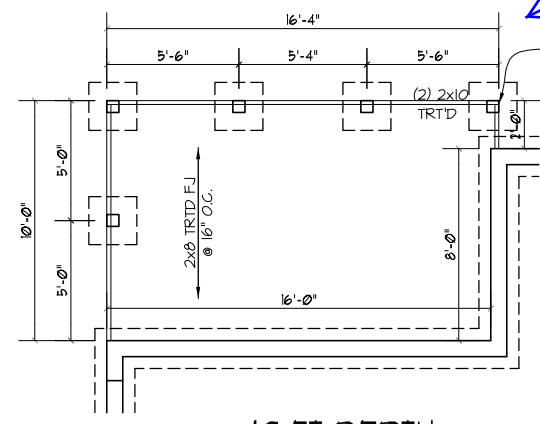

10 FT DEPTH SCREEN PORCH OPTION

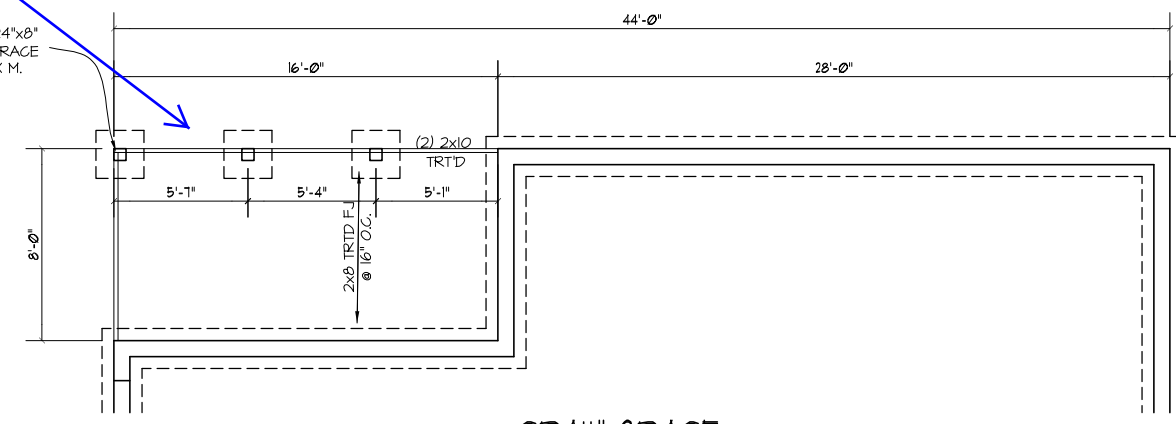

CRAWLSPACE FOUNDATION

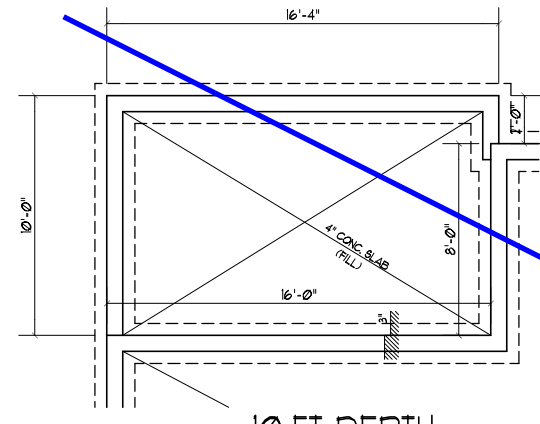

10 FT DEPTH SCREEN PORCH OPTION

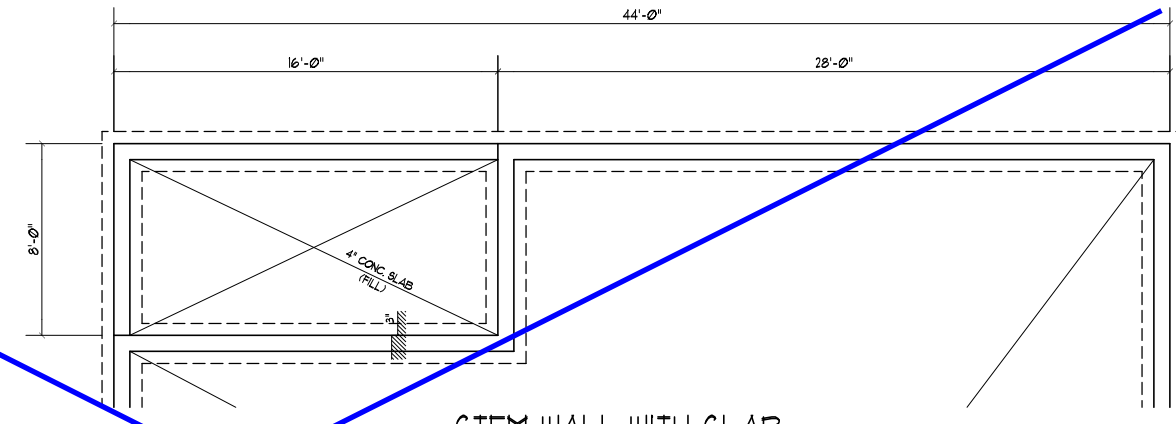

STEM WALL WITH SLAB FOUNDATION

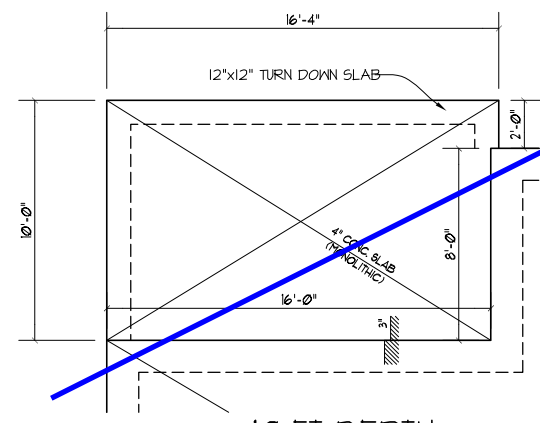

10 FT DEPTH SCREEN PORCH OPTION

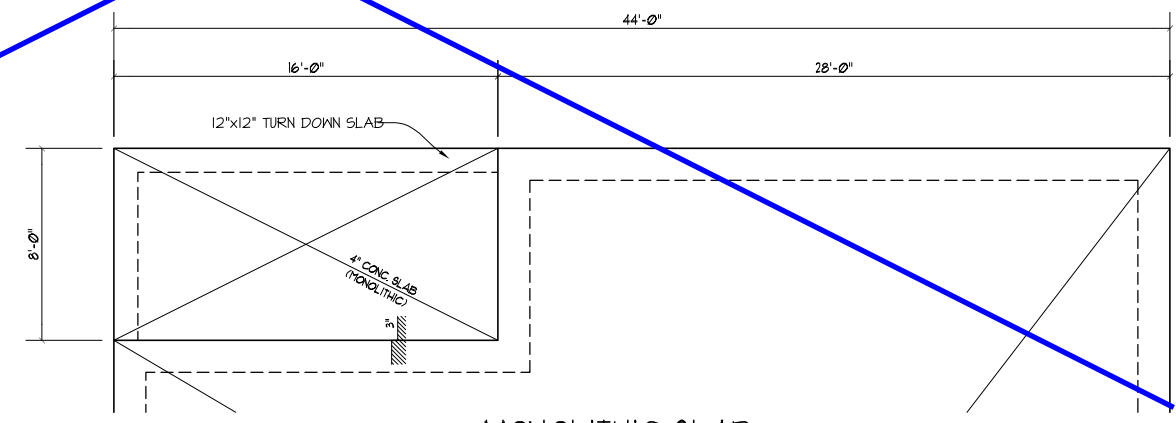

MONOLITHIC SLAB FOUNDATION

OPTIONAL SCREEN PORCH FOUNDATION PLANS  
 SCALE: ..... 1/8"=1'-0"

**WOOD "I" JOISTS**  
(SHALL BE ONE OF THE FOLLOWING):

- TJI 210 BY I-LEVEL
- LPI 20 PLUS BY LP
- BCI 5000s I.B BY BC

- ALL WOOD "I" JOISTS SHALL BE INSTALLED ACCORDING TO MANUFACTURER'S SPECIFICATIONS.
- INSTALL SQUASH BLOCKS, WEB STIFFENERS, ETC. AS REQUIRED BY AND ACCORDING TO THE I-JOIST MANUFACTURER'S SPECIFICATIONS AND INSTRUCTIONS.
- HANGERS FOR I-JOISTS ARE THE RESPONSIBILITY OF THE I-JOIST SUPPLIER.

STRUCTURAL DESIGN BY:  
SOUTHERN ENGINEERS, P.A.  
3716 BENSON DRIVE RALEIGH, NC 27609  
LICENSE: C-1287, PHONE: 919-878-1617  
PROJECT #: 21-2316-GR

- Engineers seal applies only to structural components on this document. Seal does not include construction means, methods, techniques, sequences, procedures or safety precautions.
- Any deviations or discrepancies on plans are to be brought to the immediate attention of Southern Engineers. Failure to do so will void Southern Engineer's liability.
- Seal is valid for a project permitted within one year from date of seal.
- Use of these plans constitutes approval of terms and conditions as defined in the customer agreement.

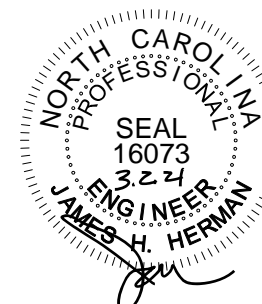

REFER TO "SD" SHEET(S) FOR STANDARD DETAILS, BRACING DETAILS AND STRUCTURAL NOTES.

Include 10 ft. Depth Screen Porch

Include Tray Ceiling

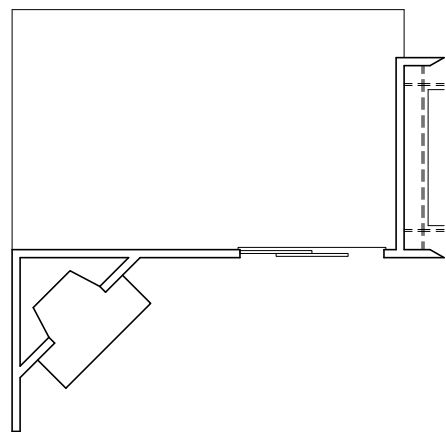

**WHOLE HOUSE BRACING SUMMARY**  
TOTAL REQUIRED BRACING: 52  
TOTAL PROVIDED BRACING: 45  
(IN FEET)

**FRAMING NOTES**

NC (2018 NRCG); Wind: 115-120 mph

- BRACING METHOD AND TYPE: CONTINUOUSLY SHEATHED WSP. CS-WSP. NOTE THAT THE WALL BRACING AMOUNT PROVIDED ON THE PLANS (DETAILS AND SPECIFICATIONS) IS GREATER THAN THE AMOUNT OF WALL BRACING REQUIRED BY SECTION R602.10 OF THE CODE. SEE NOTES BELOW FOR DETAILS AND SPECIFICATIONS FOR WALL BRACING AND WALL FRAMING.
- EXTERIOR WALL SHEATHING: WALLS SHALL BE BRACED BY SHEATHING WALLS ON ALL STORIES WITH WOOD STRUCTURAL PANEL SHEATHING (WSP) (EXPOSURE B: 7/16", EXPOSURE C: 15/32"). SHEATHING SHALL BE ATTACHED WITH 8d NAILS AT A 6"X12" NAILING PATTERN (6" OC AT PANEL EDGES AND 12" OC AT INTERMEDIATE SUPPORTS). INSTALL BLOCKING AT ALL PANEL EDGES.
- WSP SHEATHING SHALL EXTEND TO THE UPPERMOST DOUBLE BEARING PLATE. BLOCK AT ROOF PER SECTION R602.10.4.5 AND ATTACH BRACED WALLS PER CODE. WSP SHEATHING BETWEEN FLOORS SHALL BE SPLICED ALONG CONTINUOUS BAND OR THE WSP SHEATHING MAY BE SPLICED ACROSS STUDS (CONTINUOUS ACROSS FLOOR SYSTEM) WITH BLOCKING AT PANEL EDGES. (MINIMUM 12" BEYOND FLOOR BREAK) OR OTHER APPROVED METHOD.
- "HD" = HOLD-DOWN: HOLD-DOWN DEVICE (NOTED AS "HD" ON PLANS) SHALL BE AN 800 POUND CAPACITY ASSEMBLY AS NOTED ON PLANS. SEE DETAILS FOR HD ASSEMBLY.  
• \*\*GROUND/FIRST FLOOR: USE "HD HOLD-DOWN DETAIL" ON SD SHEET (OR EQUIV.)  
• \*\*UPPER FLOORS: ATTACH BASE OF KING STUD WITH A SIMPSON CS22 STRAP DOWN ACROSS THE BAND AND DOWN TO A STUD BELOW OR HEADER BELOW. EXTEND STRAP 1" MIN ALONG EACH STUD (OR HEADER) AND ATTACH EACH END W/ (1) 8d NAILS.
- INTERIOR BRACED WALL: (NOTED AS "IBW" ON PLANS) ATTACH 1/2" GYPSUM BOARD (GB) ON EACH SIDE OF WALL WITH A MIN. OF 5d COOLER NAILS OR #6 SCREWS @ 1' O.C. ALONG THE EDGES AND AT INTERMEDIATE SUPPORTS.
- INTERIOR BRACED WALL-WOOD STRUCTURAL PANEL: (NOTED AS "IBW-WSP" ON PLANS) ATTACH ONE SIDE WITH 3/8" WSP SHEATHING WITH 8d NAILS AT A 6"X12" NAILING PATTERN (6" OC AT PANEL EDGES AND 12" OC AT INTERMEDIATE SUPPORTS). INSTALL BLOCKING AT ALL PANEL EDGES. ATTACH GB OVER WSP AS REQUIRED. ATTACH OPPOSITE SIDE WITH 1/2" GB WITH A MIN. OF 5d COOLER NAILS OR #6 SCREWS @ 1' O.C. ALONG THE EDGES AND AT INTERMEDIATE SUPPORTS.

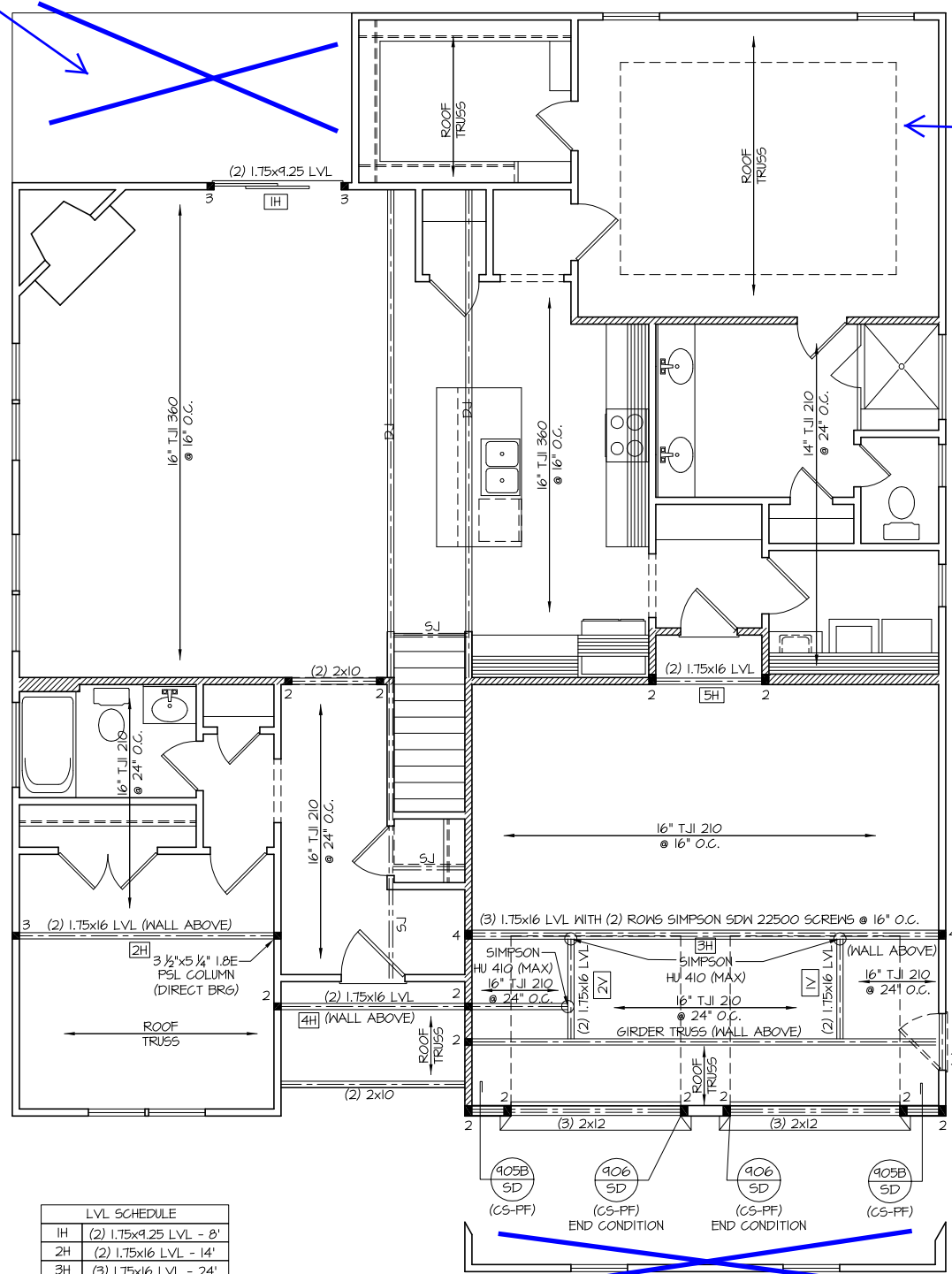

LVL SCHEDULE	
1H	(2) 1.75x9.25 LVL - 8'
2H	(2) 1.75x16 LVL - 14'
3H	(3) 1.75x16 LVL - 24'
4H	(2) 1.75x16 LVL - 16'
5H	(2) 1.75x16 LVL - 6'
1V	(2) 1.75x16 LVL - 6'
2V	(2) 1.75x16 LVL - 6'

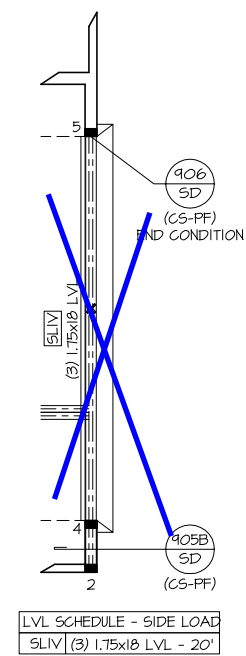

**TRUSS SYSTEM REQUIREMENTS**  
NC (2018 NRCG); Wind: 115-120 mph

- TRUSS SYSTEM LAYOUTS (PLACEMENT PLANS) SHALL BE DESIGNED IN ACCORDANCE WITH SEALED STRUCTURAL PLANS. ANY NEED TO CHANGE TRUSSES SHALL BE COORDINATED WITH SOUTHERN ENGINEERS.
- TRUSS SCHEMATICS (PROFILES) SHALL BE PREPARED AND SEALED BY TRUSS MANUFACTURER.
- ALL TRUSSES SHALL BE DESIGNED FOR BEARING ON SPF #2 OR #3 PLATES OR LEDGERS (UNO).
- ALL REQUIRED ANCHORS FOR TRUSSES DUE TO UPLIFT OR BEARING SHALL MEET THE REQUIREMENTS AS SPECIFIED ON THE TRUSS SCHEMATICS.

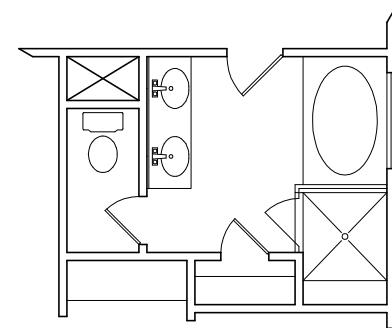

**HEADER/BEAM & COLUMN NOTES**

- ALL EXTERIOR AND LOAD BEARING HEADERS SHALL BE MIN. (2)2x6 (4" WALL) OR (3)2x6 (6" WALL) WITH (1) SUPPORT STUD, UNLESS NOTED OTHERWISE.
- THE NUMBER SHOWN AT BEAM AND HEADER SUPPORTS INDICATES THE NUMBER OF STUD POCKET OR COLUMN. THE NUMBER OF KING STUDS AT EACH END OF HEADERS IN EXTERIOR WALLS SHALL BE ACCORDING TO ITEM "d" IN TABLE R602.3(5) OR AS BELOW PER NCD01 COMMENTARY "KING STUDS AT WALL OPENINGS" REVISED 1-9-2020:  
  - UP TO 3' SPAN: (1) KING STUD
  - OVER 3' UP TO 6' SPAN: (2) KING STUDS
  - OVER 6' UP TO 9' SPAN: (3) KING STUDS
  - OVER 9' UP TO 12' SPAN: (4) KING STUDS
  - OVER 12' UP TO 15' SPAN: (5) KING STUDS

**ELEVATION "C"**  
**FIRST FLOOR CEILING /**  
**STRUCTURAL PLAN**  
**W/ BEDROOM #4 / BATH OPTION**

SCALE: ----- 1/8" = 1'-0"

- NOTES:
- 1) SHADED WALLS DENOTE LOAD BEARING WALLS.
  - 2) ■ DENOTES SOLID STUDS.

**DYNAMIC DESIGN GROUP, INC**  
David D Grorud  
(919) 601-1406  
DynamicDesignGroup@gmail.com

The drawings and specifications (plans) contained on these pages are the property of Dynamic Design Group and are offered to the named client or contractor for a conditional one time use. The conditional use is limited to the lot and subdivision specified herein, and only for said location. COPYRIGHT 2021  
Contractor shall verify all conditions and dimensions prior to construction. Any error or omissions shall be reported to Dynamic Design Group for corrections or justification. Once construction has commenced, the contractor shall assume all responsibility. Dimensions govern over scale, code governs over dimensions.

CAPITOL  
PROJECT FOR: CITY HOMES  
LOCATION: MULTI  
LOT: MULTI  
SUBDIVISION: MULTI  
COUNTY: MULTI

**PAXTON III**  
PLAN NAME  
**B-2379-44GR**  
PLAN I.D.  
**2-2-21**  
DATE

**S-2C**  
SHEET

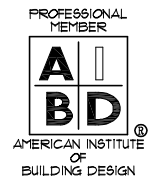
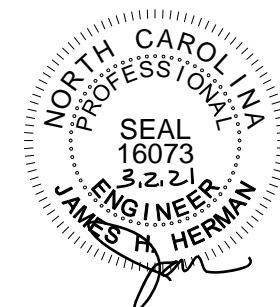

STRUCTURAL DESIGN BY:  
 SOUTHERN ENGINEERS, P.A.  
 3716 BENSON DRIVE RALEIGH, NC 27609  
 LICENSE: C-1287, PHONE: 919-878-1617  
 PROJECT #: 21-2316-GR

- Engineers seal applies only to structural components on this document. Seal does not include construction means, methods, techniques, sequences, procedures or safety precautions.
- Any deviations or discrepancies on plans are to be brought to the immediate attention of Southern Engineers. Failure to do so will void Southern Engineer's liability.
- Seal is valid for a project permitted within one year from date of seal.
- Use of these plans constitutes approval of terms and conditions as defined in the customer agreement.

REFER TO "SD" SHEET(S) FOR STANDARD DETAILS, BRACING DETAILS AND STRUCTURAL NOTES.

**DYNAMIC DESIGN GROUP, INC**  
 David D Grorud  
 (919) 601-1406  
 DynamicDesignGroup@gmail.com

The drawings and specifications (plans) contained on these pages are the property of Dynamic Design Group and are offered to the named client or contractor for a conditional one time use. The conditional use is limited to the lot and subdivision specified herein, and only for said location. COPYRIGHT 2021

Contractor shall verify all conditions and dimensions prior to construction. Any error or omissions shall be reported to Dynamic Design Group for corrections or justification. Once construction has commenced, the contractor shall assume all responsibility. Dimensions govern over scale, code governs over dimensions.

CAPITOL  
 PROJECT FOR: CITY HOMES  
 LOCATION: MULTI  
 LOT: MULTI  
 SUBDIVISION: MULTI  
 COUNTY: MULTI

**PAXTON III**  
 PLAN NAME  
**B-2379-44GR**  
 PLAN I.D.  
**2-2-21**  
 DATE

**S-2** SCREEN PORCH OPTIONS SHEET

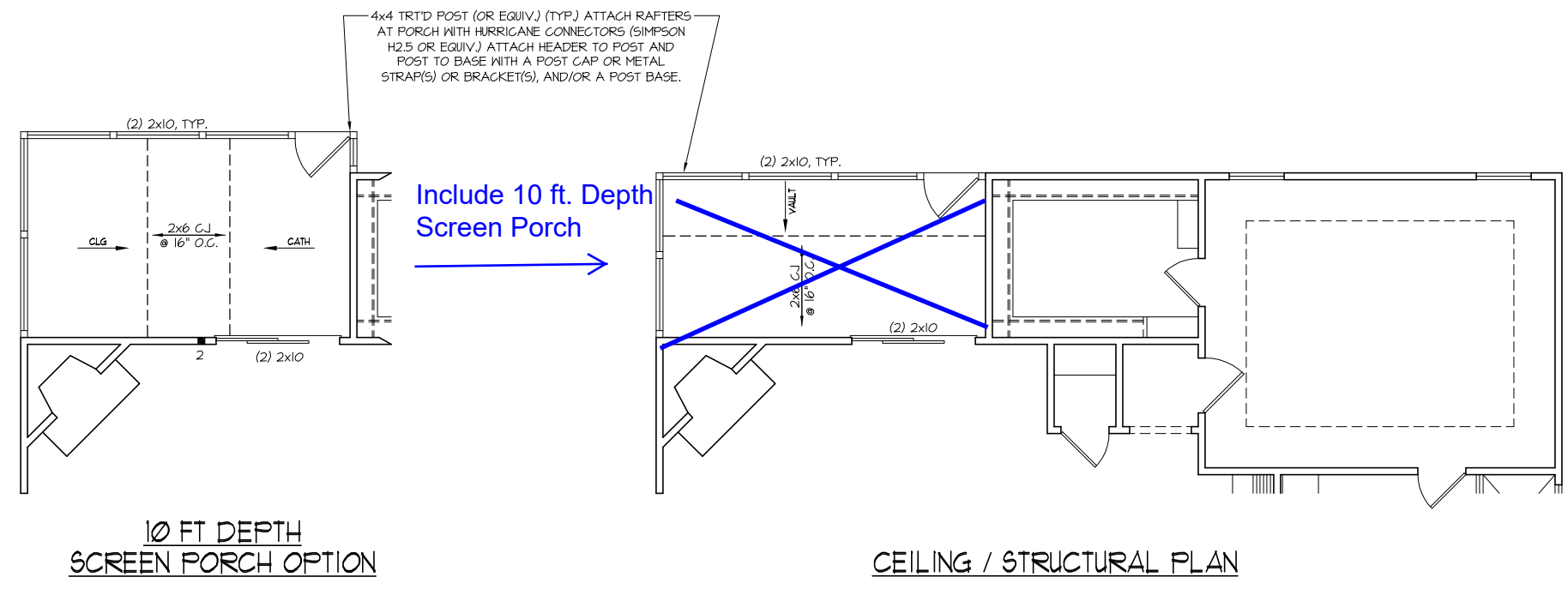

10 FT DEPTH SCREEN PORCH OPTION

CEILING / STRUCTURAL PLAN

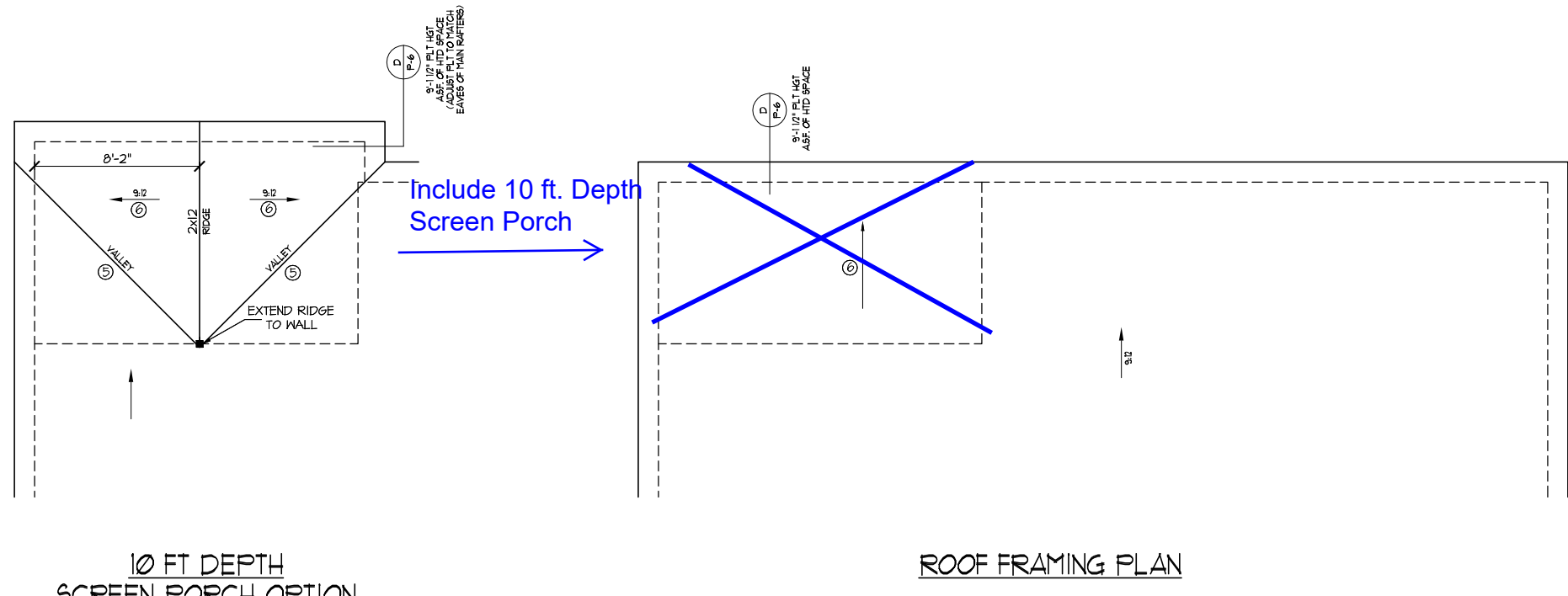

10 FT DEPTH SCREEN PORCH OPTION

ROOF FRAMING PLAN

**ROOF FRAMING NOTES:**

- NC (2018 NRC): Wind: 115-120 mph
- ① 2x8 @ 16" O.C. WITH 2x10 RIDGE, UNO.
  - ② (2) 2x10 OR 1.75x11.875 LVL HIP. (2) 2x10 HIPs MAY BE SPLICED WITH A MIN. 6'-0" OVERLAP AT CENTER
  - ③ (2) 2x10 OR 1.75x9.25 LVL VALLEY. DO NOT SPLICE VALLEYS
  - ④ 1.75x11.875 LVL OR (2)1.75x9.25 LVL VALLEY
  - ⑤ FALSE FRAME VALLEY ON 2x10 FLAT PLATE
  - ⑥ 2x6 RAFTERS @ 16" O.C. W/ 2x8 RIDGE, UNO.
  - ⑦ 2x10 RAFTERS @ 16" O.C. W/ 2x12 RIDGE, UNO.
  - ⑧ EXTEND RIDGE 12" BEYOND INTERSECTION
- "SR" = SINGLE RAFTER
  - "DR" = DOUBLE RAFTER
  - "TR" = TRIPLE RAFTER
  - "RS" = ROOF SUPPORT
  - "■" = (3) STUD OR 4x4 POST FOR ROOF SUPPORT (USE 2x6 OR 6x6 FOR SUPPORT POSTS OVER 10'-0" IN HEIGHT)
  - ATTACH VAULTED RAFTERS WITH HURRICANE CLIPS: SIMPSON "H-2.5A" OR EQUIVALENT
  - INSTALL RAFTER TIES AND COLLAR TIES PER SECTION R802.3.1 OF THE 2018 NC RESIDENTIAL CODE.

**SCREEN PORCH OPTIONS**  
 SCALE: ..... 1/8" = 1'-0"

**FRAMING NOTES**

NC (2018 NCRG): Wind: 115-120 mph

- BRACING METHOD AND TYPE: CONTINUOUSLY SHEATHED WSP. CS-WSP. NOTE THAT THE WALL BRACING AMOUNT PROVIDED ON THE PLANS (DETAILS AND SPECIFICATIONS) IS GREATER THAN THE AMOUNT OF WALL BRACING REQUIRED BY SECTION R602.10 OF THE CODE. SEE NOTES BELOW FOR DETAILS AND SPECIFICATIONS FOR WALL BRACING AND WALL FRAMING.
- EXTERIOR WALL SHEATHING: WALLS SHALL BE BRACED BY SHEATHING WALLS ON ALL STORIES WITH WOOD STRUCTURAL PANEL SHEATHING (WSP) (EXPOSURE B: 7/16", EXPOSURE C: 15/32"). SHEATHING SHALL BE ATTACHED WITH 8d NAILS AT A 6"/12" NAILING PATTERN (6" OC AT PANEL EDGES AND 12" OC AT INTERMEDIATE SUPPORTS). INSTALL BLOCKING AT ALL PANEL EDGES.
- WSP SHEATHING SHALL EXTEND TO THE UPPERMOST DOUBLE BEARING PLATE. BLOCK AT ROOF PER SECTION R602.10.4.5 AND ATTACH BRACED WALLS PER CODE. WSP SHEATHING BETWEEN FLOORS SHALL BE SPLICED ALONG CONTINUOUS BAND OR THE WSP SHEATHING MAY BE SPLICED ACROSS STUDS (CONTINUOUS ACROSS FLOOR SYSTEM) WITH BLOCKING AT PANEL EDGES. (MINIMUM 12" BEYOND FLOOR BREAK) OR OTHER APPROVED METHOD.
- "HD" = HOLD-DOWN. HOLD-DOWN DEVICE (NOTED AS "HD" ON PLANS) SHALL BE AN 800 POUND CAPACITY ASSEMBLY AS NOTED ON PLANS. SEE DETAILS FOR HD ASSEMBLY.
  - \*\*GROUND/FIRST FLOOR: USE "HD HOLD-DOWN DETAIL" ON SD SHEET (OR EQUIV.)
  - \*\*UPPER FLOORS: ATTACH BASE OF KING STUD WITH A SIMPSON C522 STRAP DOWN ACROSS THE BAND AND DOWN TO A STUD BELOW OR HEADER BELOW. EXTEND STRAP 7" MIN ALONG EACH STUD (OR HEADER) AND ATTACH EACH END W/ (1) 8d NAILS.
- INTERIOR BRACED WALL: (NOTED AS "IBW" ON PLANS) ATTACH 1/2" GYPSUM BOARD (GB) ON EACH SIDE OF WALL WITH A MIN. OF 5d COOLER NAILS OR #6 SCREWS @ 1" O.C. ALONG THE EDGES AND AT INTERMEDIATE SUPPORTS.
- INTERIOR BRACED WALL-WOOD STRUCTURAL PANEL: (NOTED AS "IBW-WSP" ON PLANS). ATTACH ONE SIDE WITH 3/8" WSP SHEATHING WITH 8d NAILS AT A 6"/12" NAILING PATTERN (6" OC AT PANEL EDGES AND 12" OC AT INTERMEDIATE SUPPORTS). INSTALL BLOCKING AT ALL PANEL EDGES. ATTACH GB OVER WSP AS REQUIRED. ATTACH OPPOSITE SIDE WITH 1/2" GB WITH A MIN. OF 5d COOLER NAILS OR #6 SCREWS @ 1" O.C. ALONG THE EDGES AND AT INTERMEDIATE SUPPORTS.

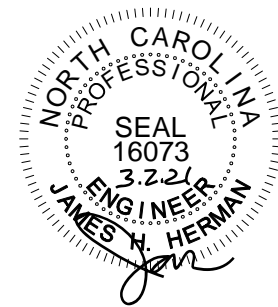
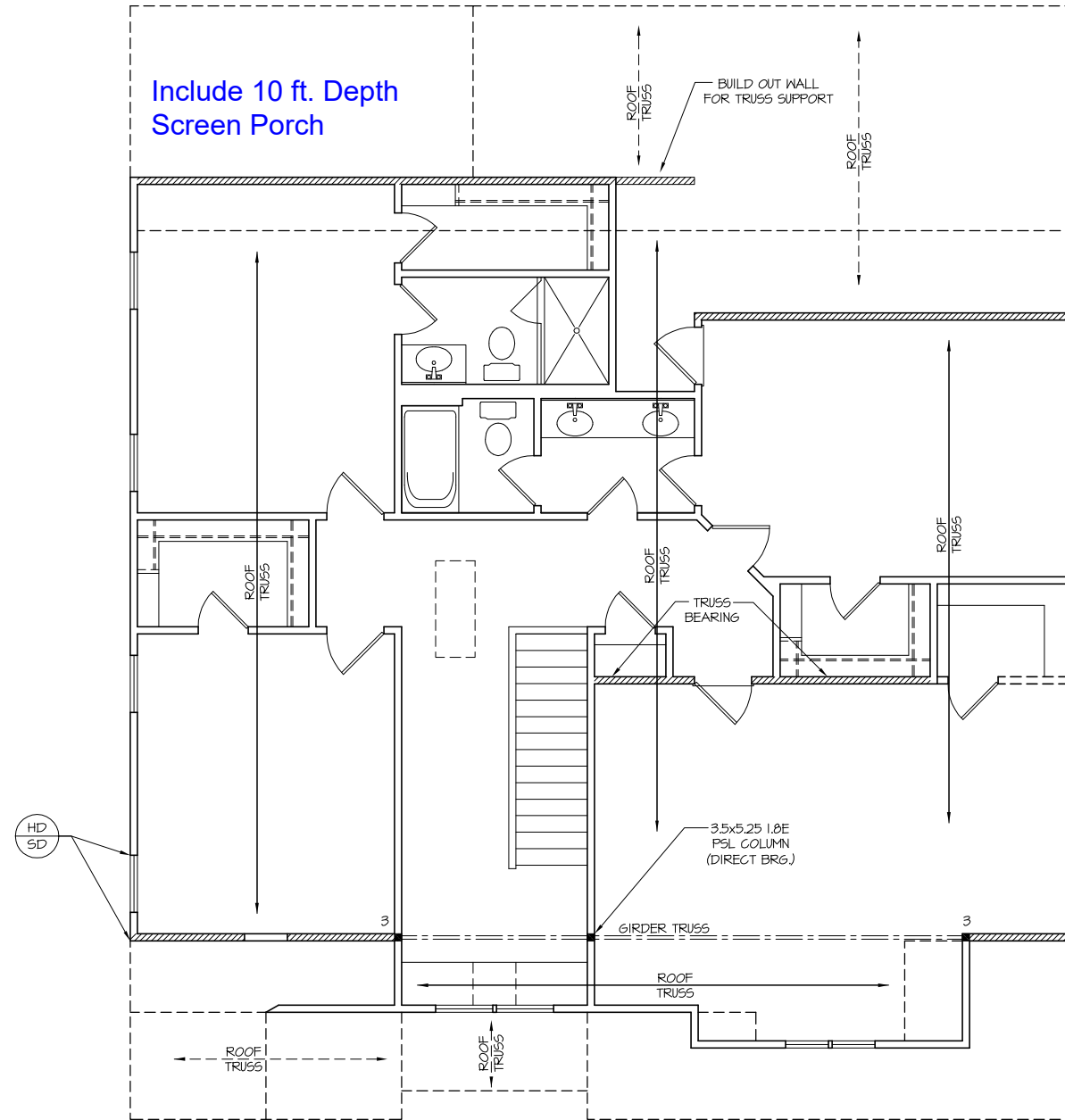

STRUCTURAL DESIGN BY:  
SOUTHERN ENGINEERS, P.A.  
3716 BENSON DRIVE RALEIGH, NC 27609  
LICENSE: C-1207, PHONE: 919-870-1617  
PROJECT #: 21-2316-GR

- Engineers seal applies only to structural components on this document. Seal does not include construction means, methods, techniques, sequences, procedures or safety precautions.
- Any deviations or discrepancies on plans are to be brought to the immediate attention of Southern Engineers. Failure to do so will void Southern Engineer's liability.
- Seal is valid for a project permitted within one year from date of seal.
- Use of these plans constitutes approval of terms and conditions as defined in the customer agreement.

REFER TO "SD" SHEET(S) FOR STANDARD DETAILS, BRACING DETAILS AND STRUCTURAL NOTES.

**TRUSS SYSTEM REQUIREMENTS**

NC (2018 NCRG): Wind: 115-120 mph

- TRUSS SYSTEM LAYOUTS (PLACEMENT PLANS) SHALL BE DESIGNED IN ACCORDANCE WITH SEALED STRUCTURAL PLANS. ANY NEED TO CHANGE TRUSSES SHALL BE COORDINATED WITH SOUTHERN ENGINEERS.
- TRUSS SCHEMATICS (PROFILES) SHALL BE PREPARED AND SEALED BY TRUSS MANUFACTURER.
- ALL TRUSSES SHALL BE DESIGNED FOR BEARING ON SPF #2 OR #3 PLATES OR LEDGERS (UNO).
- ALL REQUIRED ANCHORS FOR TRUSSES DUE TO UPLIFT OR BEARING SHALL MEET THE REQUIREMENTS AS SPECIFIED ON THE TRUSS SCHEMATICS.

**HEADER/BEAM & COLUMN NOTES**

- ALL EXTERIOR AND LOAD BEARING HEADERS SHALL BE MIN. (2)2x6 (4" WALL) OR (3)2x6 (6" WALL) WITH (1) SUPPORT STUD, UNLESS NOTED OTHERWISE.
- THE NUMBER SHOWN AT BEAM AND HEADER SUPPORTS INDICATES THE NUMBER OF SUPPORT STUDS REQUIRED IN STUD POCKET OR COLUMN. THE NUMBER OF KING STUDS AT EACH END OF HEADERS IN EXTERIOR WALLS SHALL BE ACCORDING TO ITEM "d" IN TABLE R602.3(5) OR AS BELOW PER NCDOL COMMENTARY "KING STUDS AT WALL OPENINGS" REVISED 1-4-2020:
  - UP TO 3' SPAN: (1) KING STUD
  - OVER 3' UP TO 6' SPAN: (2) KING STUDS
  - OVER 6' UP TO 9' SPAN: (3) KING STUDS
  - OVER 9' UP TO 12' SPAN: (4) KING STUDS
  - OVER 12' UP TO 15' SPAN: (5) KING STUDS

ELEVATION "C"  
SECOND FLOOR CEILING /  
STRUCTURAL PLAN  
W/ BEDROOM #4 / BATH OPTION

SCALE ----- 1/8"=1'-0"

NOTES:  
1) SHADED WALLS DENOTE LOAD BEARING WALLS.  
2) ■ DENOTES SOLID STUDS.

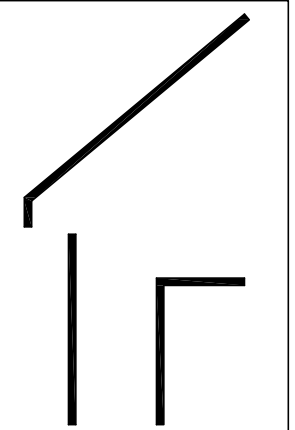

**DYNAMIC  
DESIGN  
GROUP, INC**

David D Grorud  
(919) 601-1406  
DynamicDesignGroup@gmail.com

The drawings and specifications (plans) contained on these pages are the property of Dynamic Design Group and are offered to the named client or contractor for a conditional one time use. The conditional use is limited to the lot and subdivision specified herein, and only for said location. COPYRIGHT 2021

Contractor shall verify all conditions and dimensions prior to construction. Any error or omissions shall be reported to Dynamic Design Group for corrections or justification. Once construction has commenced, the contractor shall assume all responsibility. Dimensions govern over scale, code governs over dimensions.

CAPITOL  
PROJECT FOR: CITY HOMES  
LOCATION: MULTI  
LOT: MULTI  
SUBDIVISION: MULTI  
COUNTY: MULTI

**PAXTON III**  
PLAN NAME  
**B-2379-44GR**  
PLAN I.D.  
**2-2-21**  
DATE

**S-3C**  
SHEET



Include 10 ft. Depth Screen Porch

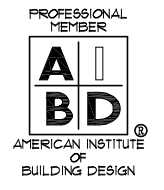
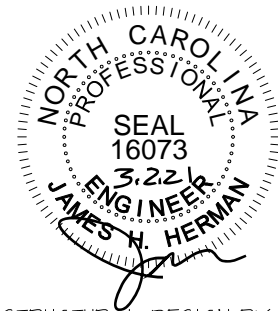
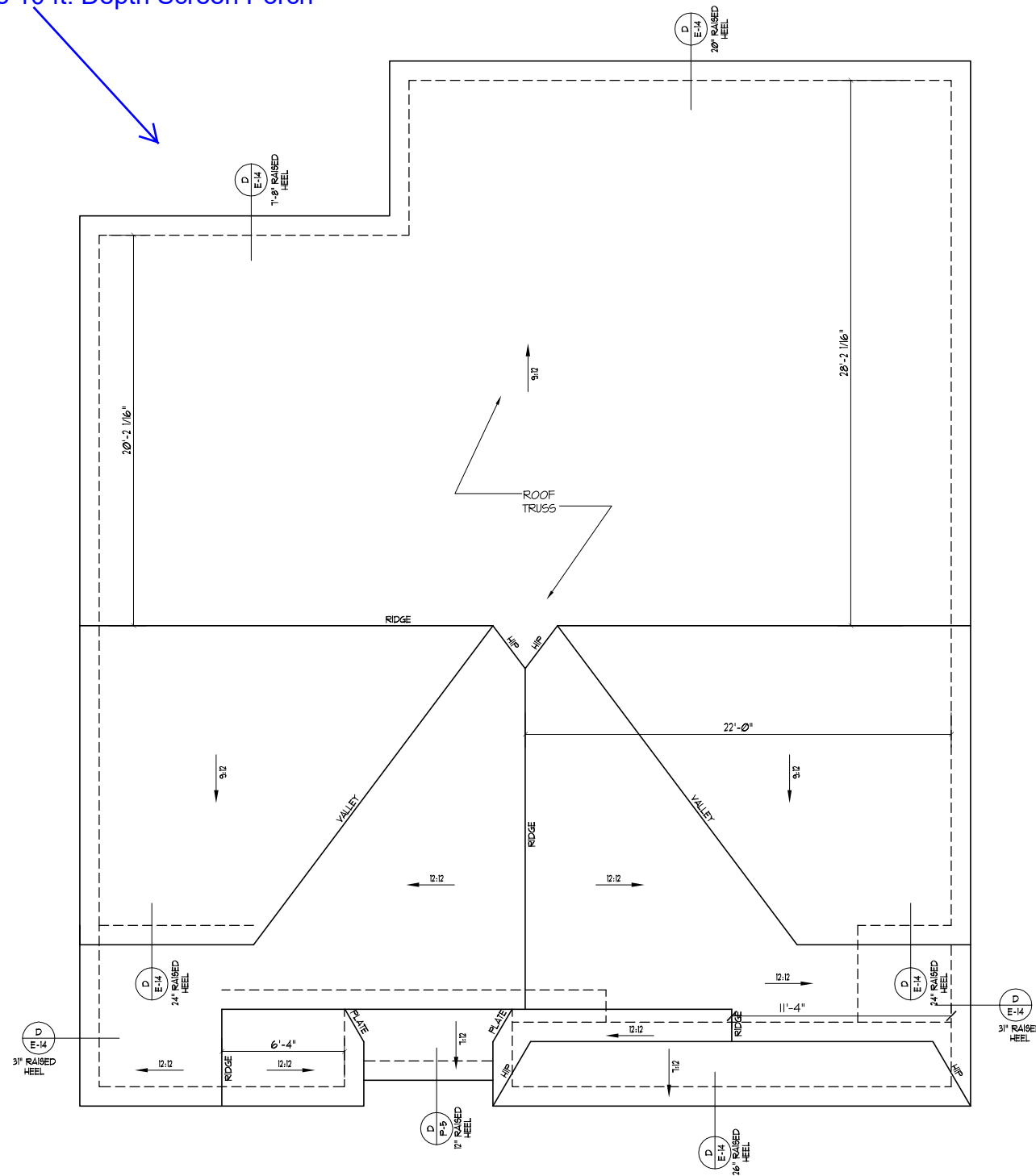

STRUCTURAL DESIGN BY:  
 SOUTHERN ENGINEERS, P.A.  
 3716 BENSON DRIVE RALEIGH, NC 27609  
 LICENSE: C-1287, PHONE: 919-878-1617  
 PROJECT #: 21-2316-GR

- Engineers seal applies only to structural components on this document. Seal does not include construction means, methods, techniques, sequences, procedures or safety precautions.
- Any deviations or discrepancies on plans are to be brought to the immediate attention of Southern Engineers. Failure to do so will void Southern Engineer's liability.
- Seal is valid for a project permitted within one year from date of seal.
- Use of these plans constitutes approval of terms and conditions as defined in the customer agreement.

REFER TO "SD" SHEET(S) FOR STANDARD DETAILS, BRACING DETAILS AND STRUCTURAL NOTES.

**TRUSS SYSTEM REQUIREMENTS**  
 NC (2018 NCR): Wind: 115-120 mph

1. TRUSS SYSTEM LAYOUTS (PLACEMENT PLANS) SHALL BE DESIGNED IN ACCORDANCE WITH SEALED STRUCTURAL PLANS. ANY NEED TO CHANGE TRUSSES SHALL BE COORDINATED WITH SOUTHERN ENGINEERS.
2. TRUSS SCHEMATICS (PROFILES) SHALL BE PREPARED AND SEALED BY TRUSS MANUFACTURER.
3. ALL TRUSSES SHALL BE DESIGNED FOR BEARING ON SPF #2 OR #3 PLATES OR LEDGERS (UNO).
4. ALL REQUIRED ANCHORS FOR TRUSSES DUE TO UPLIFT OR BEARING SHALL MEET THE REQUIREMENTS AS SPECIFIED ON THE TRUSS SCHEMATICS.

ATTIC VENTILATION	
REQUIRED	
* 2271	SQ. FT. OF ATTIC / 300 = 7.59 SQ. FT. OF INLET & OUTLET
PROVIDED	
(INLET) SOFFIT	07 SQ. FT. PER x 64 LINEAR FT. = 4.48 SQ. FT. (TOTAL OF 48% OF VENT. INLET)
(OUTLET) RIDGE	11 SQ. FT. PER x 44 LINEAR FT. = 4.84 SQ. FT. (TOTAL OF 52% OF VENT. OUTLET)
	9.32 TOTAL SQ. FT. OF VENT.

\* INCLUDES OPT SCREEN PORCH

**ELEVATION "C"**  
**ROOF FRAMING PLAN**  
 W/ BEDROOM #4 / BATH OPTION  
 SCALE ----- 1/8"=1'-0"

- NOTES:
- 1) SEE SHEET D-1 FOR DETAILS.
  - 2) DIMENSIONS ARE FROM EXT. OF FRAMING TO CENTER LINE OF RIDGE.

**DYNAMIC DESIGN GROUP, INC**  
 David D Grorud  
 (919) 601-1406  
 DynamicDesignGroup@gmail.com

The drawings and specifications (plans) contained on these pages are the property of Dynamic Design Group and are offered to the named client or contractor for a conditional one time use. The conditional use is limited to the lot and subdivision specified herein, and only for said location. COPYRIGHT 2021

Contractor shall verify all conditions and dimensions prior to construction. Any error or omissions shall be reported to Dynamic Design Group for corrections or justification. Once construction has commenced, the contractor shall assume all responsibility. Dimensions govern over scale, code governs over dimensions.

CAPITOL  
 PROJECT FOR: CITY HOMES  
 LOCATION: MULTI  
 LOT: MULTI  
 SUBDIVISION: MULTI  
 COUNTY: MULTI

**PAXTON III**

PLAN NAME: B-2379-44GR      DATE: 2-2-21

PLAN I.D.:

**S-4C**  
 SHEET

**STRUCTURAL NOTES**

NC (2018 NCRC): Wind: 115-120 mph

- ENGINEER'S SEAL APPLIES ONLY TO STRUCTURAL COMPONENTS INCLUDING ROOF RAFTERS, HIPs, VALLEYS, RIDGES, FLOORS, WALLS, BEAMS AND HEADERS, COLUMNS, GANTRYBEAMS, OFFSET LOAD BEARING WALLS, PIER & GIRDER SYSTEM, FOOTING, AND PILING SYSTEM. ENGINEER'S SEAL DOES NOT CERTIFY DIMENSIONAL ACCURACY OR ARCHITECTURAL LAYOUT INCLUDING ROOF SYSTEM. ALL REQUIREMENTS FOR PROFESSIONAL CERTIFICATION SHALL BE PROVIDED BY THE APPROPRIATE PROFESSIONAL. SOUTHERN ENGINEERS, P.A. CERTIFIES ONLY THE STRUCTURAL COMPONENTS AS SPECIFICALLY STATED.
- ALL CONSTRUCTION SHALL CONFORM TO THE LATEST REQUIREMENTS OF RESIDENTIAL CODE, PLUS ALL LOCAL CODES AND REGULATIONS. THE STRUCTURAL ENGINEER IS NOT RESPONSIBLE FOR, AND WILL NOT HAVE CONTROL OF, CONSTRUCTION MEANS, METHODS, TECHNIQUES, SEQUENCES OR PROCEDURES, OR FOR SAFETY PRECAUTIONS AND PROGRAMS IN CONNECTION WITH THE CONSTRUCTION WORK. NOR WILL THE ENGINEER BE RESPONSIBLE FOR THE CONTRACTOR'S FAILURE TO CARRY OUT THE CONSTRUCTION WORK IN ACCORDANCE WITH THE CONTRACT DOCUMENTS. "CONSTRUCTION REVIEW" SERVICES ARE NOT PART OF OUR CONTRACT. ALL MEMBERS SHALL BE FRAMED, ANCHORED, TIED AND BRACED IN ACCORDANCE WITH GOOD CONSTRUCTION PRACTICE AND THE BUILDING CODE.
- DESIGN LOADS (LISTED AS: LIVE LOAD, DEAD LOAD, DEFLECTION)
  - ROOMS OTHER THAN SLEEPING ROOMS: (40 PSF, 10 PSF, L/360)
  - SLEEPING ROOMS: (30 PSF, 10 PSF, L/360)
  - ATTIC WITH PERMANENT STAIR: (40 PSF, 10 PSF, L/360)
  - ATTIC WITHOUT PERMANENT STAIR: (20 PSF, 10 PSF, L/360)
  - ATTIC WITHOUT STORAGE: (10 PSF, 10 PSF, L/240)
  - STAIRS: (40 PSF, 10 PSF, L/360)
  - EXTERIOR BALCONIES: (60 PSF, 10 PSF, L/360)
  - DECKs: (40 PSF, 10 PSF, L/360)
  - GUARDRAILS AND HANDRAILS: (200 LBS)
  - PASSENGER VEHICLE GARAGES: (50 PSF, 10 PSF, L/360)
  - FIRE ESCAPES: (40 PSF, 10 PSF, L/360)
  - SNOW: (20 PSF)
- WALLS SHALL BE BRACED BY SHEATHING WALLS ON ALL STORIES WITH WOOD STRUCTURAL PANELS. SEE FRAMING NOTES FOR THICKNESS AND NAILING REQUIREMENTS.
- SEE APPENDIX M (DCA6) FOR EXTERIOR DECK REQUIREMENTS INCLUDING ATTACHMENTS FOR LATERAL LOADS.
- CONCRETE SHALL HAVE A MINIMUM 28 DAY STRENGTH OF 3000 PSI AND A MAXIMUM SLUMP OF 5 INCHES UNLESS NOTED OTHERWISE (NO). AIR ENTRAINMENT PER TABLE 402.2. ALL CONCRETE SHALL BE PROPORTIONED, MIXED, HANDLED, SAMPLED, TESTED, AND PLACED IN ACCORDANCE WITH ACI STANDARDS. ALL SAMPLES FOR PUMPING SHALL BE TAKEN FROM THE EXIT END OF THE PUMP. CONTROL JOINTS IN SLABS SHALL BE SPACED ON A GRID OF +30 TIMES THE DEPTH (D). CONTROL JOINTS SHALL BE SAWCUT TO A DEPTH OF 1/3. (I.E. 4" CONCRETE SLABS SHALL HAVE 1 1/2" DEEP CONTROL JOINTS SAWCUT IN SLAB ON A +10'-0" x +10'-0" GRID).
- ALLOWABLE SOIL BEARING PRESSURE ASSUMED TO BE 2000 PSF. THE CONTRACTOR MUST CONTACT A GEOTECHNICAL ENGINEER AND THE STRUCTURAL ENGINEER IF UNSATISFACTORY SUBSURFACE CONDITIONS ARE ENCOUNTERED. THE SURFACE AREA ADJACENT TO THE FOUNDATION WALL SHALL BE PROVIDED WITH ADEQUATE DRAINAGE, AND SHALL BE GRADED SO AS TO DRAINSURFACE WATER AWAY FROM FOUNDATION WALLS.
- ALL FRAMING LUMBER SHALL BE SPF #2 (Fb = 875 PSI) UNLESS NOTED OTHERWISE (NO). ALL TREATED LUMBER SHALL BE SYP # 2. PLATE MATERIAL MAY BE SPF # 3 OR SYP #3 (Fb(perp) = 425 PSI - MIN).
  - L.V.L. SHALL BE LAMINATED VENEER LUMBER: Fb=2600 PSI, Fv=285 PSI, E=1.4x10<sup>10</sup> PSI.
  - P.S.L. SHALL BE PARALLEL STRAND LUMBER: Fb=2400 PSI, Fv=240 PSI, E=2.0x10<sup>10</sup> PSI.
  - L.S.L. SHALL BE LAMINATED STRAND LUMBER: Fb=2250 PSI, Fv=400 PSI, E=1.55x10<sup>10</sup> PSI. INSTALL ALL CONNECTIONS PER MANUFACTURERS INSTRUCTIONS.
- ALL ROOF TRUSS AND I-JOIST LAYOUTS SHALL BE PREPARED IN ACCORDANCE WITH THE SEALED STRUCTURAL DRAWINGS. TRUSSES AND I-JOISTS SHALL BE INSTALLED ACCORDING TO THE MANUFACTURE'S SPECIFICATIONS. ANY CHANGE IN TRUSS OR I-JOIST LAYOUT SHALL BE COORDINATED WITH SOUTHERN ENGINEERS.
- ALL STRUCTURAL STEEL SHALL BE ASTM A-36. STEEL BEAMS SHALL BE SUPPORTED AT EACH END WITH A MINIMUM BEARING LENGTH OF 3 1/2 INCHES AND FULL FLANGE WIDTH. PROVIDE SOLID BEARING FROM BEAM SUPPORT TO FOUNDATION. BEAMS SHALL BE ATTACHED TO EACH SUPPORT WITH TWO LAG SCREWS (1/2" DIAMETER x 4" LONG). LATERAL SUPPORT IS CONSIDERED ADEQUATE PROVIDING THE JOIST ARE TOE NAILED TO THE SOLE PLATE, AND SOLE PLATE IS NAILED OR BOLTED TO THE BEAM FLANGE @ 48" O.C. ALL STEEL TUBING SHALL BE ASTM A500. LAP ALL REBAR SPLICES 30 BAR DIAMETERS.
- REBAR SHALL BE DEFORMED STEEL, ASTM615, GRADE 60.
- FLITCH BEAMS SHALL BE BOLTED TOGETHER USING (2) ROWS OF 1/2" DIAMETER BOLTS (ASTM A325) WITH WASHERS PLACED UNDER THE THREADED END OF BOLT. BOLTS SHALL BE SPACED AT 24" O.C. (MAX), AND STAGGERED AT THE TOP AND BOTTOM OF BEAM (2" EDGE DISTANCE), WITH 2 BOLTS LOCATED AT 6" FROM EACH END.
- BRICK LINTELS (WHEN REQUIRED) SHALL BE 3 1/2"x3 1/2"x1/4" STEEL ANGLE FOR UP TO 6'-0" SPAN AND 6"x4"x5/16" STEEL ANGLE WITH 6" LEG VERTICAL FOR SPANS UP TO 9'-0". SEE PLANS FOR SPANS OVER 9'-0". SEE ALSO SECTION RT03.7.3 LINTELS.

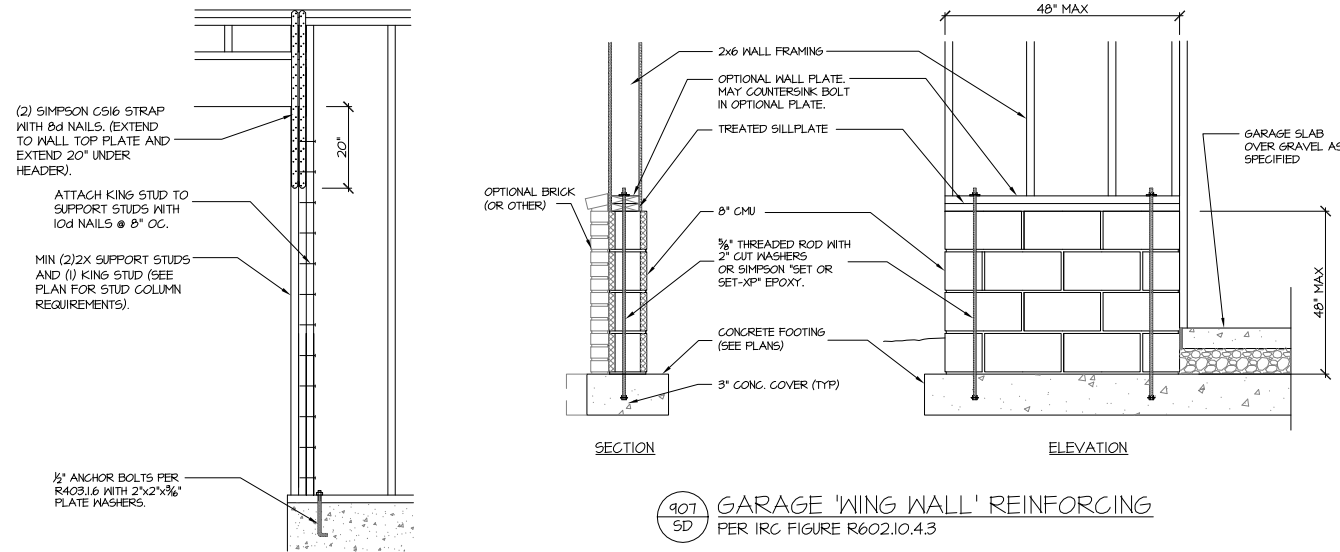

**906** CS-PF: END CONDITION DETAIL  
 (FOR USE WITH SINGLE CS-PF CONDITION)  
 DETAIL AND APPLICATION BASED ON NCRC FIGURE R602.10.1 - PORTAL FRAME CONSTRUCTION

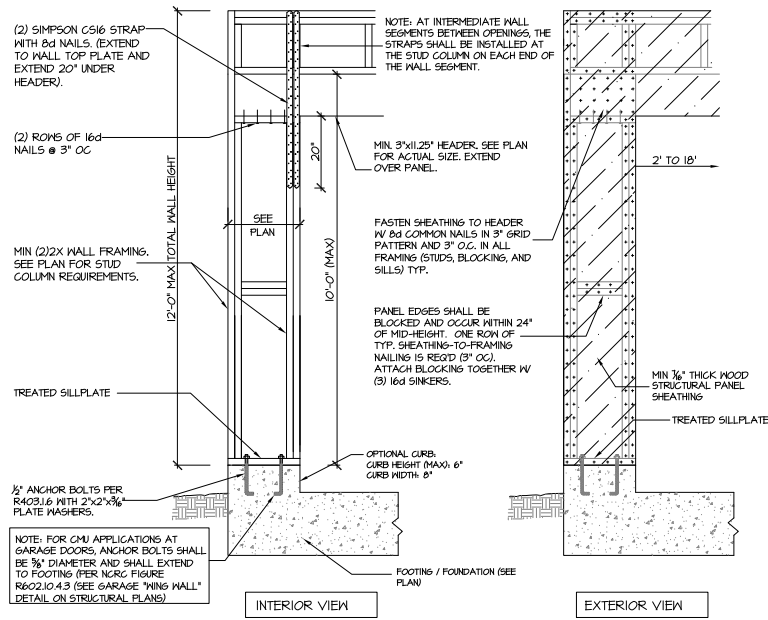

**905B** CS-PF: CONTINUOUS PORTAL FRAME CONSTRUCTION  
 DETAIL AND APPLICATION BASED ON NCRC FIGURE R602.10.1 - PORTAL FRAME CONSTRUCTION

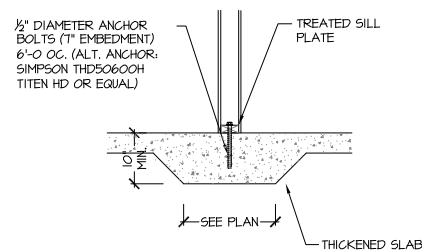

**115-120** **104A** THICKENED SLAB  
 MPH SD (INTERIOR BEARING WALL)

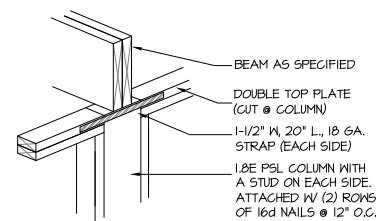

**205B** DIRECT BEAM BEARING  
 SD NTS

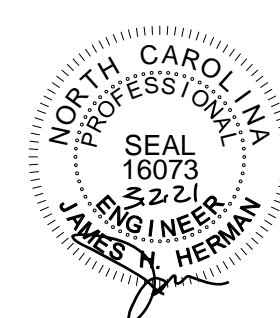

STRUCTURAL DESIGN BY:  
 SOUTHERN ENGINEERS, P.A.  
 3716 BENSON DRIVE RALEIGH, NC 27609  
 LICENSE: C-1287, PHONE: 919-878-1617  
 PROJECT #: 21-2316-GR

- Engineers seal applies only to structural components on this document. Seal does not include construction means, methods, techniques, sequences, procedures or safety precautions.
- Any deviations or discrepancies on plans are to be brought to the immediate attention of Southern Engineers. Failure to do so will void Southern Engineers' liability.
- Seal is valid for a project permitted within one year from date of seal.
- Use of these plans constitutes approval of terms and conditions as defined in the customer agreement.

**DYNAMIC DESIGN GROUP, INC**

David D Grorud  
 (919) 601-1406  
 DynamicDesignGroup@gmail.com

The drawings and specifications (plans) contained on these pages are the property of Dynamic Design Group and are offered to the named client or contractor for a conditional one time use. The conditional use is limited to the lot and subdivision specified herein, and only for said location. COPYRIGHT 2021

Contractor shall verify all conditions and dimensions prior to construction. Any error or omissions shall be reported to Dynamic Design Group for corrections or justification. Once construction has commenced, the contractor shall assume all responsibility. Dimensions govern over scale, code governs over dimensions.

PROJECT FOR: CAPITOL CITY HOMES  
 LOCATION: MULTI  
 LOT: MULTI  
 SUBDIVISION: MULTI  
 COUNTY: MULTI

**PAXTON III**  
 PLAN NAME  
**B-2379-44GR**  
 PLAN I.D.  
**2-2-21**  
 DATE

**SD SHEET**



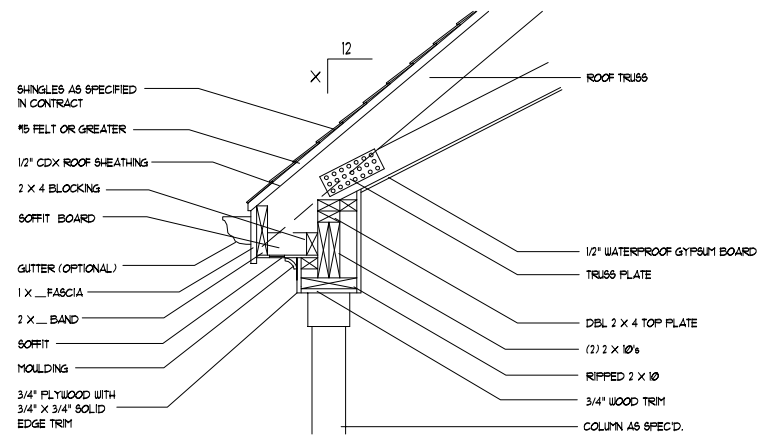

D  
P-6 (NTS)

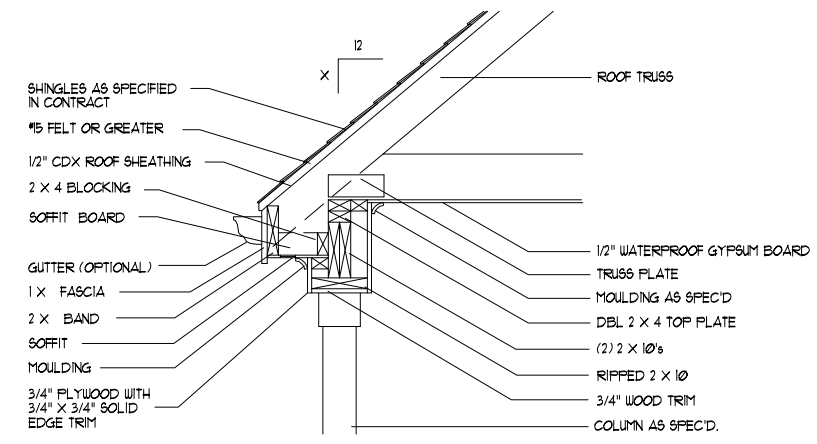

D  
P-5 (NTS)

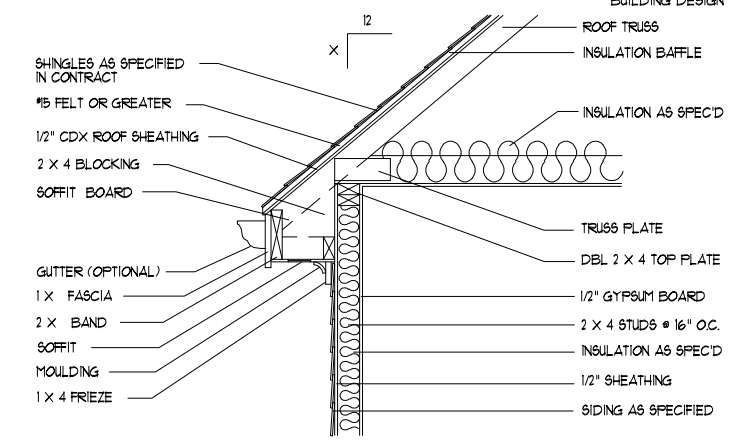

D  
E-14 (NTS)

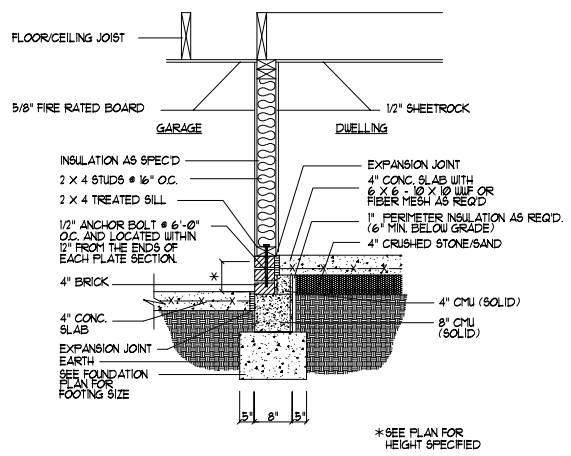

D  
GU-1A (NTS)

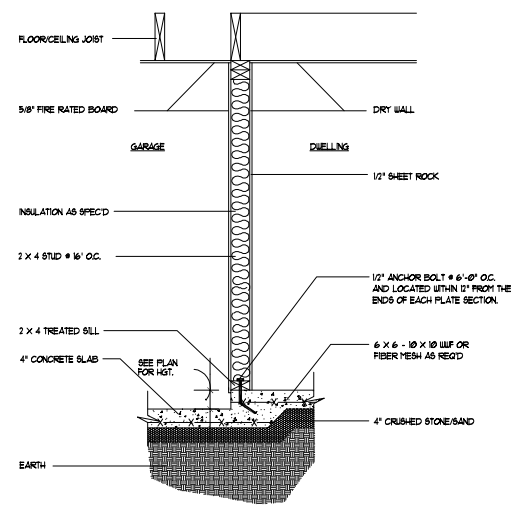

D  
GU-1B (NTS)

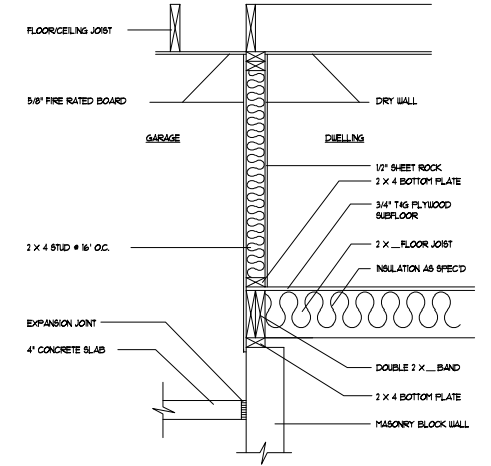

D  
GU-1C (NTS)

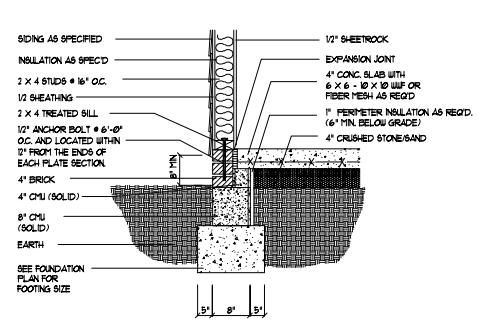

D  
F-16A (NTS)

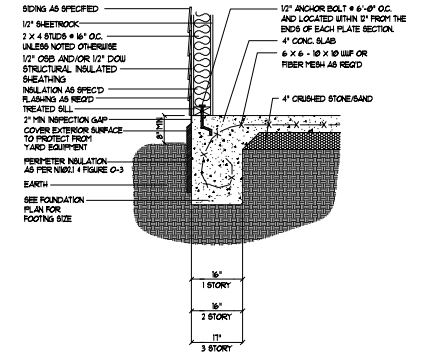

D  
F-16B (NTS)

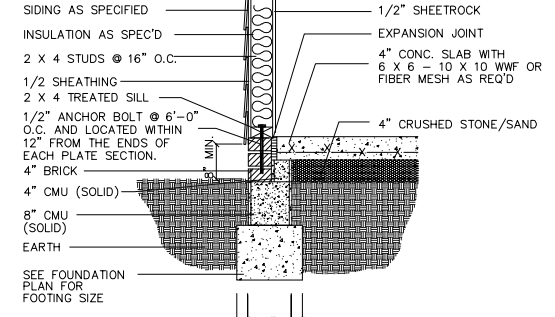

D  
F-16A (NTS)

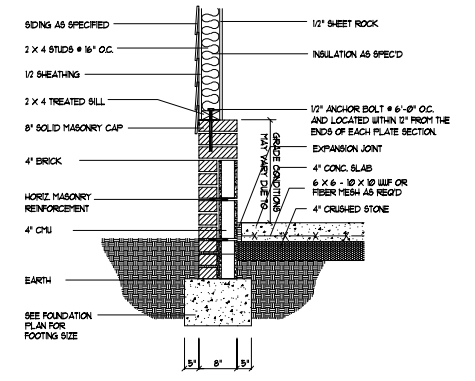

D  
F-16 (NTS)

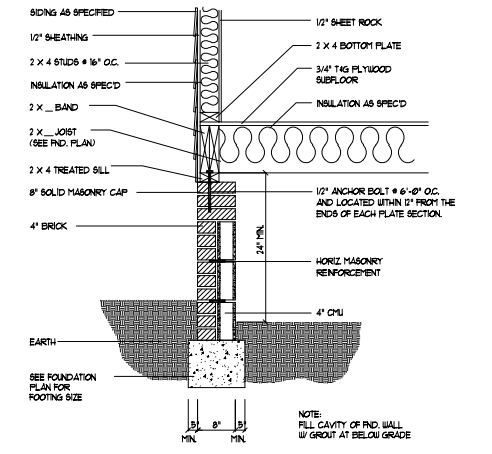

D  
F-16 (NTS)

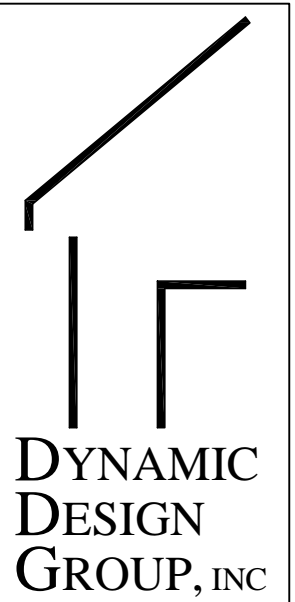

David D Grourd  
 (919) 601-1406  
 DynamicDesignGroup@gmail.com

The drawings and specifications (plans) contained on these pages are the property of Dynamic Design Group and are offered to the named client or contractor for a conditional one time use. The conditional use is limited to the lot and subdivision specified herein, and only for said location. COPYRIGHT 2021

Contractor shall verify all conditions and dimensions prior to construction. Any error or omissions shall be reported to Dynamic Design Group for corrections or justification. Once construction has commenced, the contractor shall assume all responsibility. Dimensions govern over scale, code governs over dimensions.

CAPITOL  
 PROJECT FOR: CITY HOMES  
 LOCATION: MULTI  
 LOT: MULTI  
 SUBDIVISION: MULTI  
 COUNTY: MULTI

**PAXTON III**  
 PLAN NAME  
**B-2379-44GR**  
 2-2-21  
 DATE  
 PLAN I.D.

**D-1A**  
 SHEET

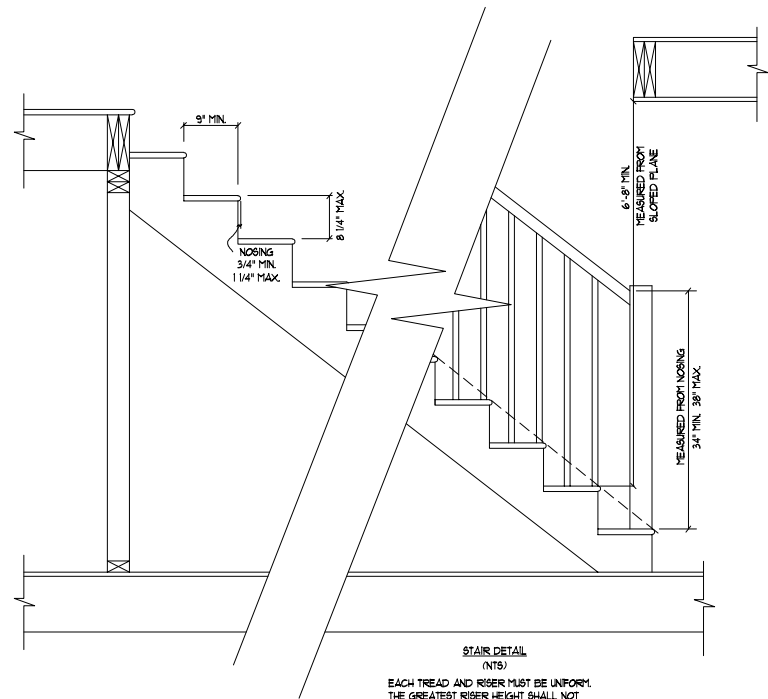

EACH TREAD AND RISER MUST BE UNIFORM. THE GREATEST RISER HEIGHT SHALL NOT EXCEED THE SMALLEST BY MORE THAN 3/8". THE GREATEST TREAD DEPTH SHALL NOT EXCEED THE SMALLEST BY MORE THAN 3/8". THE TOP AND BOTTOM RISER OF INTERIOR STAIRS SHALL NOT EXCEED THE SMALLEST RISER BY MORE THAN 3/4". SEE FLOOR PLAN FOR ACTUAL SPECIFICATIONS.

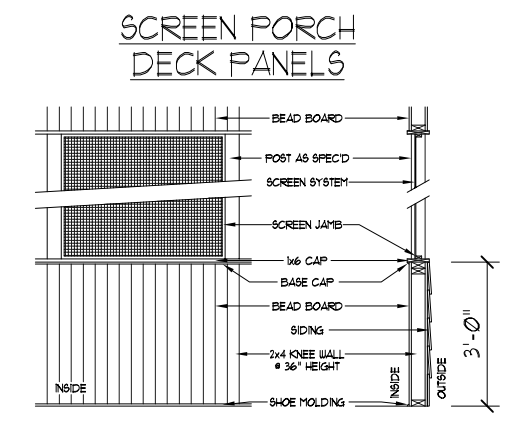
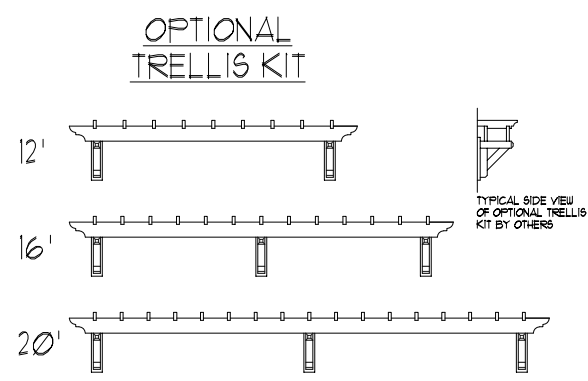

**DYNAMIC DESIGN GROUP, INC**  
 David D Grorud  
 (919) 601-1406  
 DynamicDesignGroup@gmail.com

The drawings and specifications (plans) contained on these pages are the property of Dynamic Design Group and are offered to the named client or contractor for a conditional one time use. The conditional use is limited to the lot and subdivision specified herein, and only for said location. COPYRIGHT 2021  
 Contractor shall verify all conditions and dimensions prior to construction. Any error or omissions shall be reported to Dynamic Design Group for corrections or justification. Once construction has commenced, the contractor shall assume all responsibility. Dimensions govern over scale, code governs over dimensions.

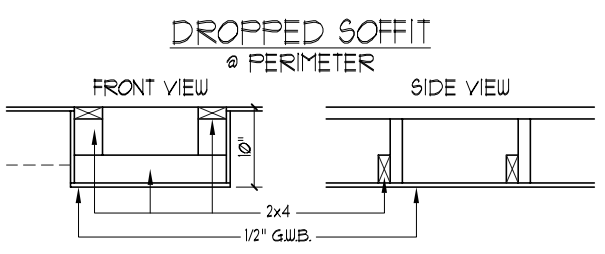

FAUX BEAM

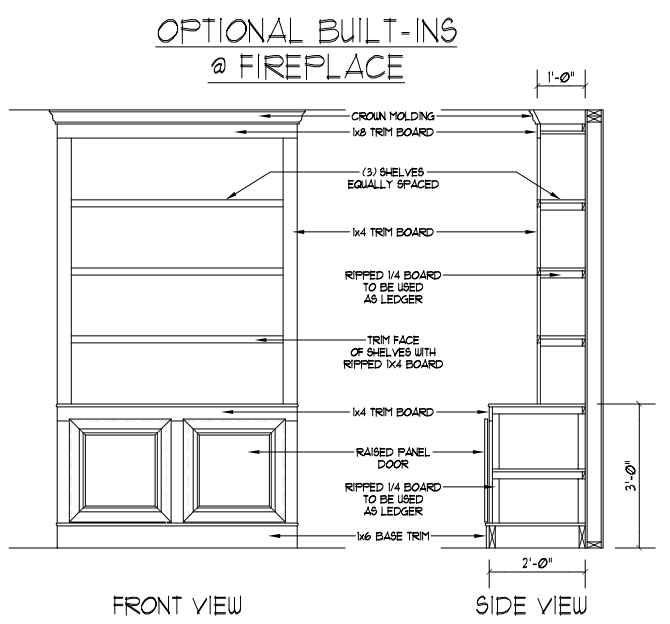
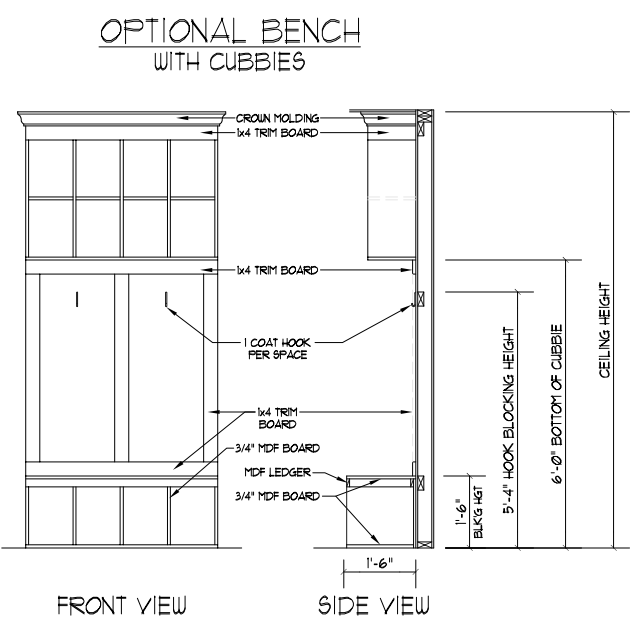
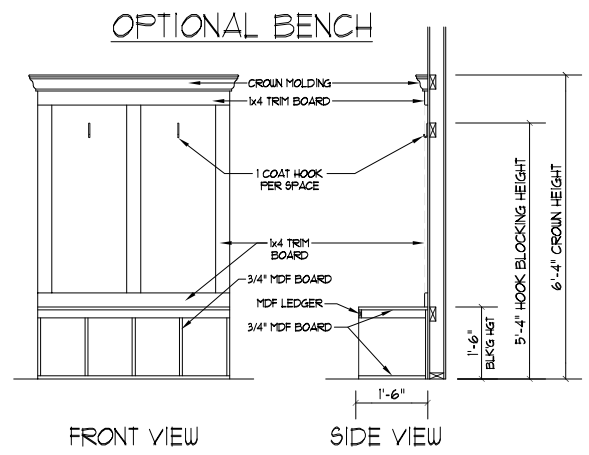
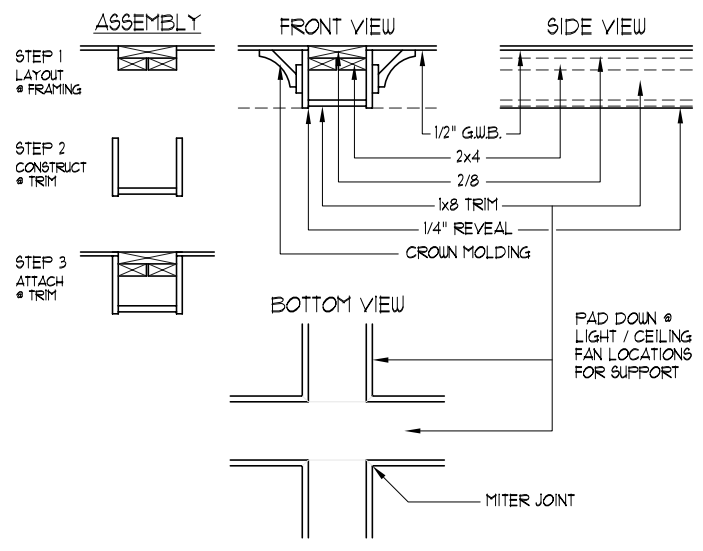

CAPITOL PROJECT FOR: CITY HOMES  
 LOCATION: MULTI  
 LOT: MULTI  
 SUBDIVISION: MULTI  
 COUNTY: MULTI

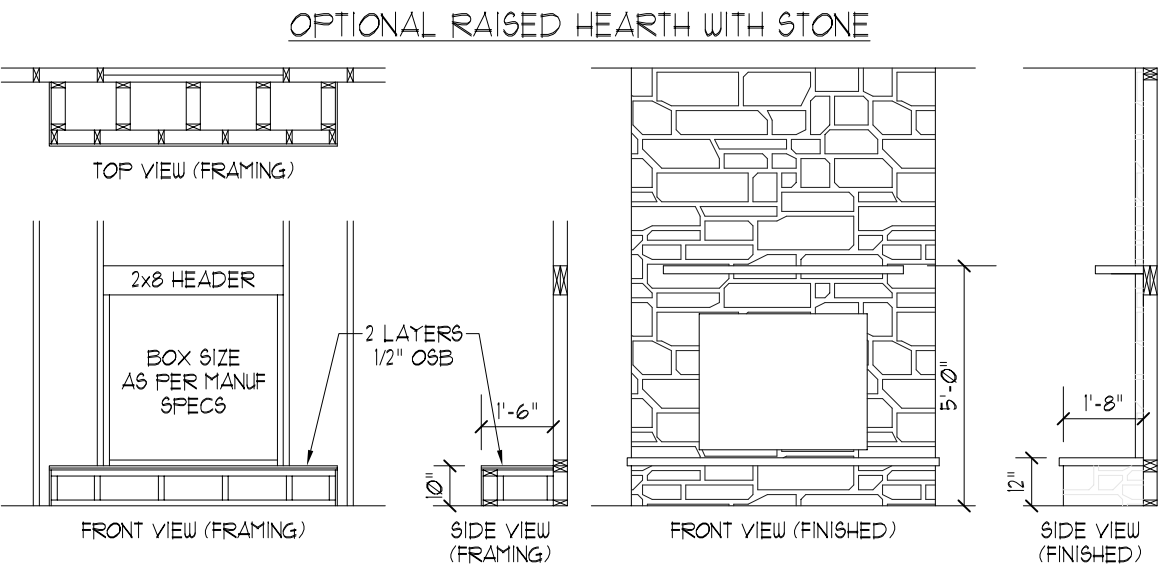
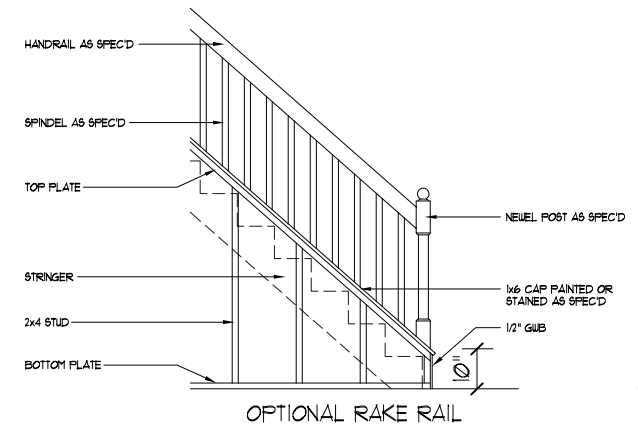

**PAXTON III**  
 PLAN NAME  
**B-2379-44GR**  
 PLAN I.D.  
**2-2-21**  
 DATE  
**D-1B**  
 SHEET