

RE: J0621-4088  
Lot 12 Pendegraft Rd.

Trenco  
818 Soundside Rd  
Edenton, NC 27932

**Site Information:**

Customer: Project Name: J0621-4088  
Lot/Block: Model:  
Address: Subdivision:  
City: State:

**General Truss Engineering Criteria & Design Loads (Individual Truss Design Drawings Show Special Loading Conditions):**

Design Code: IRC2015/TPI2014 Design Program: MiTek 20/20 8.3  
Wind Code: ASCE 7-10 Wind Speed: 130 mph  
Roof Load: 40.0 psf Floor Load: N/A psf

This package includes 13 individual, dated Truss Design Drawings and 0 Additional Drawings.

No.	Seal#	Truss Name	Date
1	E15207762	A1	6/29/2021
2	E15207763	A2	6/29/2021
3	E15207764	A2-P	6/29/2021
4	E15207765	A3	6/29/2021
5	E15207766	A4	6/29/2021
6	E15207767	B1	6/29/2021
7	E15207768	B2	6/29/2021
8	E15207769	G01	6/29/2021
9	E15207770	G02	6/29/2021
10	E15207771	M01	6/29/2021
11	E15207772	M02	6/29/2021
12	E15207773	P1	6/29/2021
13	E15207774	P2	6/29/2021

The truss drawing(s) referenced above have been prepared by Truss Engineering Co. under my direct supervision based on the parameters provided by Comtech, Inc - Fayetteville.

Truss Design Engineer's Name: Galinski, John

My license renewal date for the state of North Carolina is December 31, 2021.

North Carolina COA: C-0844

IMPORTANT NOTE: The seal on these truss component designs is a certification that the engineer named is licensed in the jurisdiction(s) identified and that the designs comply with ANSI/TPI 1. These designs are based upon parameters shown (e.g., loads, supports, dimensions, shapes and design codes), which were given to TRENCO. Any project specific information included is for TRENCO customers file reference purpose only, and was not taken into account in the preparation of these designs. TRENCO has not independently verified the applicability of the design parameters or the designs for any particular building. Before use, the building designer should verify applicability of design parameters and properly incorporate these designs into the overall building design per ANSI/TPI 1, Chapter 2.



June 29, 2021

Job	Truss	Truss Type	Qty	Ply	Lot 12 Pendegrift Rd.	E15207762
J0621-4088	A1	GABLE	1	1		

Comtech, Inc., Fayetteville, NC - 28314,

8.330 s Oct 7 2020 MiTek Industries, Inc. Mon Dec 14 10:48:00 2020 Page 1

ID:0iJ2hz3vp6ahZXSx7jdYHSym1hi-z4B2pRAPgSwwlbnk396\_J6BPxktQ4gWRzTfR19y940z

0-10-8 18-0-0 36-0-0 36-10-8  
 0-10-8 18-0-0 18-0-0 0-10-8

Scale = 1:61.3

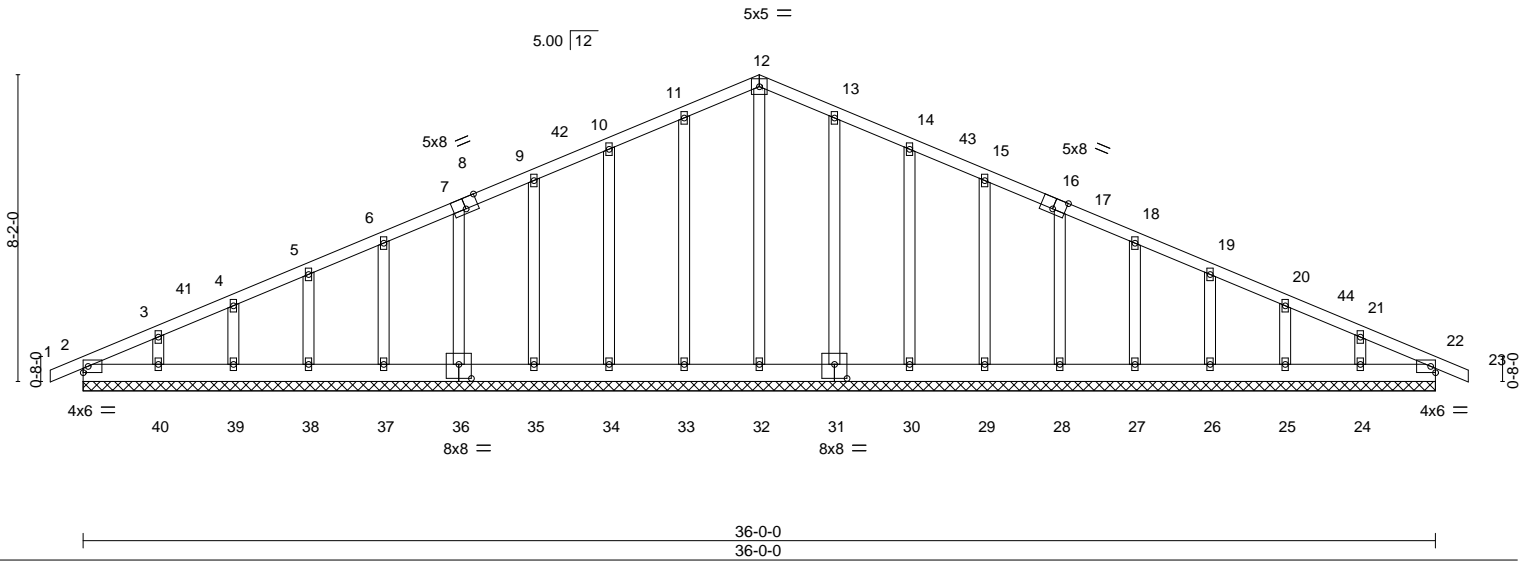

Plate Offsets (X,Y)-- [7:0-1-14,0-0-0], [8:0-4-0,Edge], [8:0-0-0,0-1-12], [16:0-4-0,Edge], [16:0-0-0,0-1-12], [17:0-1-14,0-0-0], [31:0-4-0,0-4-8], [36:0-4-0,0-4-8]

LOADING (psf)	SPACING-	CSL	DEFL.	in (loc)	l/defl	L/d	PLATES	GRIP
TCLL 20.0	Plate Grip DOL 1.15	TC 0.06	Vert(LL) -0.00	22	n/r	120	MT20	244/190
TCDL 10.0	Lumber DOL 1.15	BC 0.02	Vert(CT) -0.00	22	n/r	120		
BCLL 0.0 *	Rep Stress Incr YES	WB 0.13	Horz(CT) 0.01	22	n/a	n/a		
BCDL 10.0	Code IRC2015/TPI2014	Matrix-S					Weight: 244 lb	FT = 20%

**LUMBER-**  
 TOP CHORD 2x4 SP No.1  
 BOT CHORD 2x6 SP No.1  
 OTHERS 2x4 SP No.2

**BRACING-**  
 TOP CHORD Structural wood sheathing directly applied or 6'-0-0 oc purlins.  
 BOT CHORD Rigid ceiling directly applied or 10'-0-0 oc bracing.

**REACTIONS.** All bearings 36-0-0.  
 (lb) - Max Horz 2=-159(LC 17)  
 Max Uplift All uplift 100 lb or less at joint(s) 2, 22, 33, 34, 35, 36, 37, 38, 39, 40, 31, 30, 29, 28, 27, 26, 25, 24  
 Max Grav All reactions 250 lb or less at joint(s) 2, 22, 32, 33, 34, 35, 36, 37, 38, 39, 40, 31, 30, 29, 28, 27, 26, 25, 24

**FORCES.** (lb) - Max. Comp./Max. Ten. - All forces 250 (lb) or less except when shown.  
 TOP CHORD 10-11=-85/252, 11-12=-101/296, 12-13=-101/296, 13-14=-85/253

- NOTES-**
- Unbalanced roof live loads have been considered for this design.
  - Wind: ASCE 7-10; Vult=130mph (3-second gust) Vasd=103mph; TCCL=6.0psf; BCDL=6.0psf; h=15ft; Cat. II; Exp C; Enclosed; MWFRS (envelope) gable end zone and C-C Corner(3) 0-10-8 to 3-6-5, Exterior(2) 3-6-5 to 18-0-0, Corner(3) 18-0-0 to 22-4-13, Exterior(2) 22-4-13 to 36-10-8 zone; C-C for members and forces & MWFRS for reactions shown; Lumber DOL=1.60 plate grip DOL=1.60
  - Truss designed for wind loads in the plane of the truss only. For studs exposed to wind (normal to the face), see Standard Industry Gable End Details as applicable, or consult qualified building designer as per ANSI/TPI 1.
  - All plates are 2x4 MT20 unless otherwise indicated.
  - Gable requires continuous bottom chord bearing.
  - Gable studs spaced at 2'-0-0 oc.
  - This truss has been designed for a 10.0 psf bottom chord live load nonconcurrent with any other live loads.
  - \* This truss has been designed for a live load of 20.0psf on the bottom chord in all areas with a clearance greater than 6'-0-0 between the bottom chord and any other members, with BCDL = 10.0psf.
  - Provide mechanical connection (by others) of truss to bearing plate capable of withstanding 100 lb uplift at joint(s) 2, 22, 33, 34, 35, 36, 37, 38, 39, 40, 31, 30, 29, 28, 27, 26, 25, 24.



December 14, 2020

Job	Truss	Truss Type	Qty	Ply	Lot 12 Pendegrift Rd.	E15207763
J0621-4088	A2	COMMON	4	1		

Comtech, Inc., Fayetteville, NC - 28314,

8.330 s Oct 7 2020 MiTek Industries, Inc. Mon Dec 14 10:48:01 2020 Page 1

ID:0iJ2hz3vp6ahZXsX7jdYHSym1hi-RGkQ0nB1RmeNNILwcteDsJkV3828p62bC7P\_Zby940y

0-10-8 9-1-12 18-0-0 26-10-4 36-0-0 36-10-8  
 0-10-8 9-1-12 8-10-4 8-10-4 9-1-12 0-10-8

Scale = 1:62.5

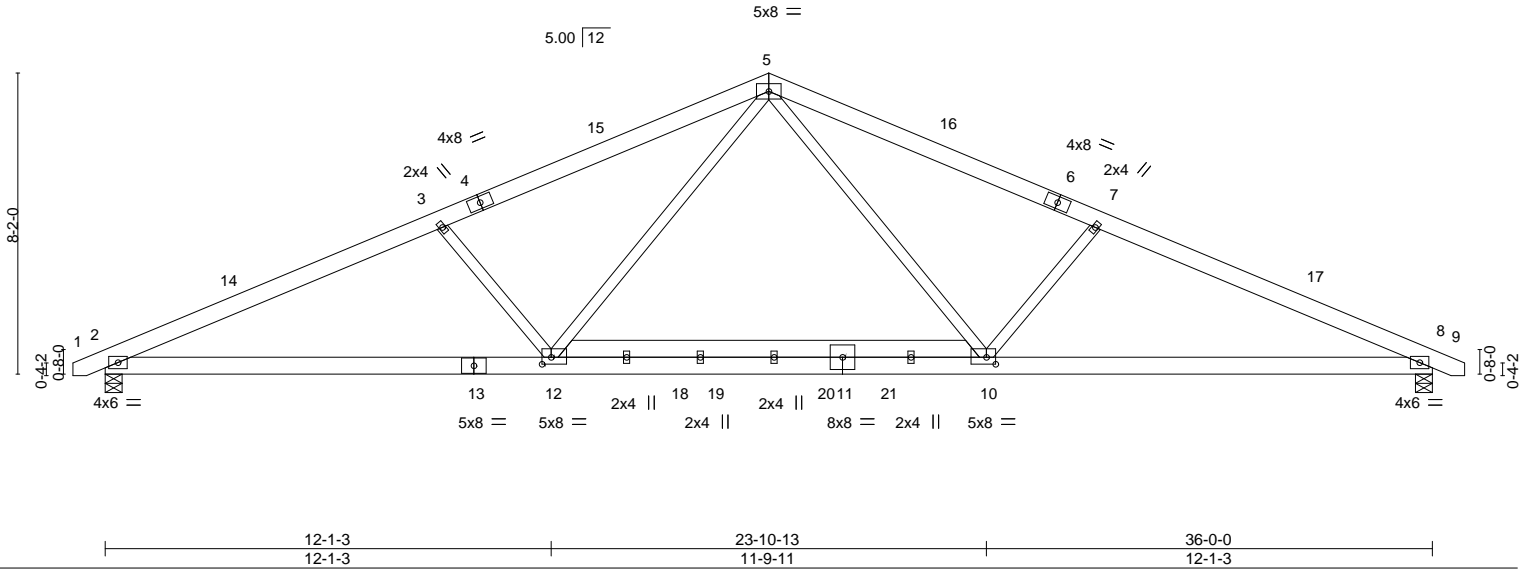

Plate Offsets (X,Y)-- [10:0-3-0,0-2-4], [12:0-3-0,0-2-4]

LOADING (psf)	SPACING-	CSI.	DEFL.	PLATES	GRIP
TCLL 20.0	2-0-0	TC 0.35	in (loc) l/defl L/d	MT20	244/190
TCDL 10.0	Plate Grip DOL 1.15	BC 0.75	Vert(LL) -0.22 10-12 >999 360		
BCLL 0.0 *	Lumber DOL 1.15	WB 0.24	Vert(CT) -0.55 10-12 >780 240		
BCDL 10.0	Rep Stress Incr YES	Matrix-S	Horz(CT) 0.08 8 n/a n/a		
	Code IRC2015/TPI2014		Wind(LL) 0.07 2-12 >999 240	Weight: 248 lb	FT = 20%

**LUMBER-**  
 TOP CHORD 2x6 SP No.1  
 BOT CHORD 2x6 SP No.1  
 WEBS 2x4 SP No.2 \*Except\*  
 10-12: 2x6 SP No.1

**BRACING-**  
 TOP CHORD Structural wood sheathing directly applied or 4-1-3 oc purlins.  
 BOT CHORD Rigid ceiling directly applied or 10-0-0 oc bracing.

**REACTIONS.** (size) 2=0-5-8, 8=0-5-8  
 Max Horz 2=-93(LC 13)  
 Max Uplift 2=-2(LC 12), 8=-2(LC 13)  
 Max Grav 2=1577(LC 1), 8=1577(LC 1)

**FORCES.** (lb) - Max. Comp./Max. Ten. - All forces 250 (lb) or less except when shown.  
 TOP CHORD 2-3=-3053/329, 3-5=-2733/293, 5-7=-2733/293, 7-8=-3053/329  
 BOT CHORD 2-12=-205/2722, 10-12=-21/1832, 8-10=-206/2722  
 WEBS 5-10=0/993, 7-10=-518/317, 5-12=0/993, 3-12=-518/317

- NOTES-**
- Unbalanced roof live loads have been considered for this design.
  - Wind: ASCE 7-10; Vult=130mph (3-second gust) Vasd=103mph; TCCL=6.0psf; BCDL=6.0psf; h=15ft; Cat. II; Exp C; Enclosed; MWFRS (envelope) and C-C Exterior(2) -0-8-5 to 3-8-8, Interior(1) 3-8-8 to 18-0-0, Exterior(2) 18-0-0 to 22-4-13, Interior(1) 22-4-13 to 36-8-5 zone:C-C for members and forces & MWFRS for reactions shown; Lumber DOL=1.60 plate grip DOL=1.60
  - 200.0lb AC unit load placed on the bottom chord, 18-0-0 from left end, supported at two points, 3-0-0 apart.
  - This truss has been designed for a 10.0 psf bottom chord live load nonconcurrent with any other live loads.
  - \* This truss has been designed for a live load of 20.0psf on the bottom chord in all areas where a rectangle 3-6-0 tall by 2-0-0 wide will fit between the bottom chord and any other members, with BCDL = 10.0psf.
  - Provide mechanical connection (by others) of truss to bearing plate capable of withstanding 100 lb uplift at joint(s) 2, 8.



December 14, 2020

Job	Truss	Truss Type	Qty	Ply	Lot 12 Pendegrift Rd.	E15207764
J0621-4088	A2-P	COMMON	2	1		

Comtech, Inc., Fayetteville, NC - 28314,

8.330 s Oct 7 2020 MiTek Industries, Inc. Mon Dec 14 10:48:03 2020 Page 1

ID:0iJ2hz3vp6ahZXSx7jdYHSym1hi-NfsBRTCHyNu5d3UJkHghxkppqHxhwH?LfRu5eTy940w

0-10-8 9-1-12 18-0-0 26-10-4 36-0-0 36-10-8  
 0-10-8 9-1-12 8-10-4 8-10-4 9-1-12 0-10-8

Scale = 1:62.5

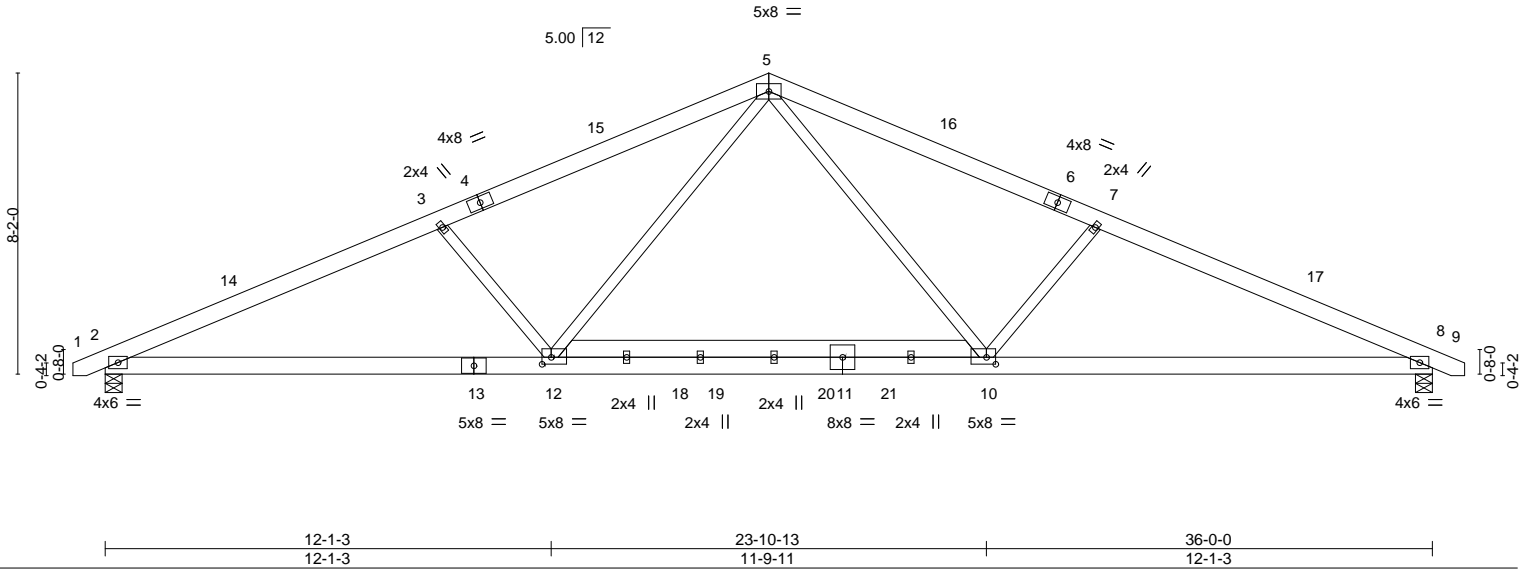

Plate Offsets (X,Y)-- [10:0-3-0,0-2-4], [12:0-3-0,0-2-4]

LOADING (psf)	SPACING-	CSI.	DEFL.	in (loc)	l/defl	L/d	PLATES	GRIP
TCLL 20.0	Plate Grip DOL 1.15	TC 0.43	Vert(LL) -0.23	10-12	>999	360	MT20	244/190
TCDL 10.0	Lumber DOL 1.15	BC 0.86	Vert(CT) -0.57	10-12	>750	240		
BCLL 0.0 *	Rep Stress Incr NO	WB 0.26	Horz(CT) 0.08	8	n/a	n/a		
BCDL 10.0	Code IRC2015/TPI2014	Matrix-S	Wind(LL) 0.08	2-12	>999	240		
							Weight: 248 lb	FT = 20%

**LUMBER-**  
 TOP CHORD 2x6 SP No.1  
 BOT CHORD 2x6 SP No.1  
 WEBS 2x4 SP No.2 \*Except\*  
 10-12: 2x6 SP No.1

**BRACING-**  
 TOP CHORD Structural wood sheathing directly applied or 3-11-4 oc purlins.  
 BOT CHORD Rigid ceiling directly applied or 10-0-0 oc bracing.

**REACTIONS.** (size) 2=0-5-8, 8=0-5-8  
 Max Horz 2=-99(LC 17)  
 Max Uplift 2=-9(LC 12), 8=-9(LC 13)  
 Max Grav 2=1669(LC 1), 8=1669(LC 1)

**FORCES.** (lb) - Max. Comp./Max. Ten. - All forces 250 (lb) or less except when shown.  
 TOP CHORD 2-3=-3227/366, 3-5=-2886/329, 5-7=-2886/329, 7-8=-3227/366  
 BOT CHORD 2-12=-233/2877, 10-12=-33/1935, 8-10=-234/2877  
 WEBS 5-10=0/1047, 7-10=-552/336, 5-12=0/1047, 3-12=-552/336

- NOTES-**
- Unbalanced roof live loads have been considered for this design.
  - Wind: ASCE 7-10; Vult=130mph (3-second gust) Vasd=103mph; TCDL=6.0psf; BCDL=6.0psf; h=15ft; Cat. II; Exp C; Enclosed; MWFRS (envelope) and C-C Exterior(2) -0-8-5 to 3-8-8, Interior(1) 3-8-8 to 18-0-0, Exterior(2) 18-0-0 to 22-4-13, Interior(1) 22-4-13 to 36-8-5 zone:C-C for members and forces & MWFRS for reactions shown; Lumber DOL=1.60 plate grip DOL=1.60
  - 200.0lb AC unit load placed on the bottom chord, 18-0-0 from left end, supported at two points, 3-0-0 apart.
  - This truss has been designed for a 10.0 psf bottom chord live load nonconcurrent with any other live loads.
  - \* This truss has been designed for a live load of 20.0psf on the bottom chord in all areas where a rectangle 3-6-0 tall by 2-0-0 wide will fit between the bottom chord and any other members, with BCDL = 10.0psf.
  - Provide mechanical connection (by others) of truss to bearing plate capable of withstanding 100 lb uplift at joint(s) 2, 8.



December 14, 2020

Job	Truss	Truss Type	Qty	Ply	Lot 12 Pendegraft Rd.	E15207765
J0621-4088	A3	COMMON	8	1		

Comtech, Inc., Fayetteville, NC - 28314,

8.330 s Oct 7 2020 MiTek Industries, Inc. Mon Dec 14 10:48:04 2020 Page 1  
 ID:0iJ2hz3vp6ahZXSx7jdYHSym1hi-rrQZfoDvjh0xED3VI?BwUyM?lL5y0Tx1u5deAwy940v

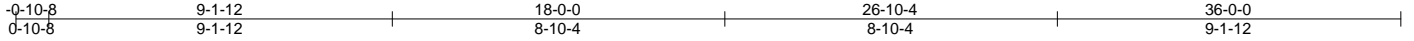

Scale = 1:61.3

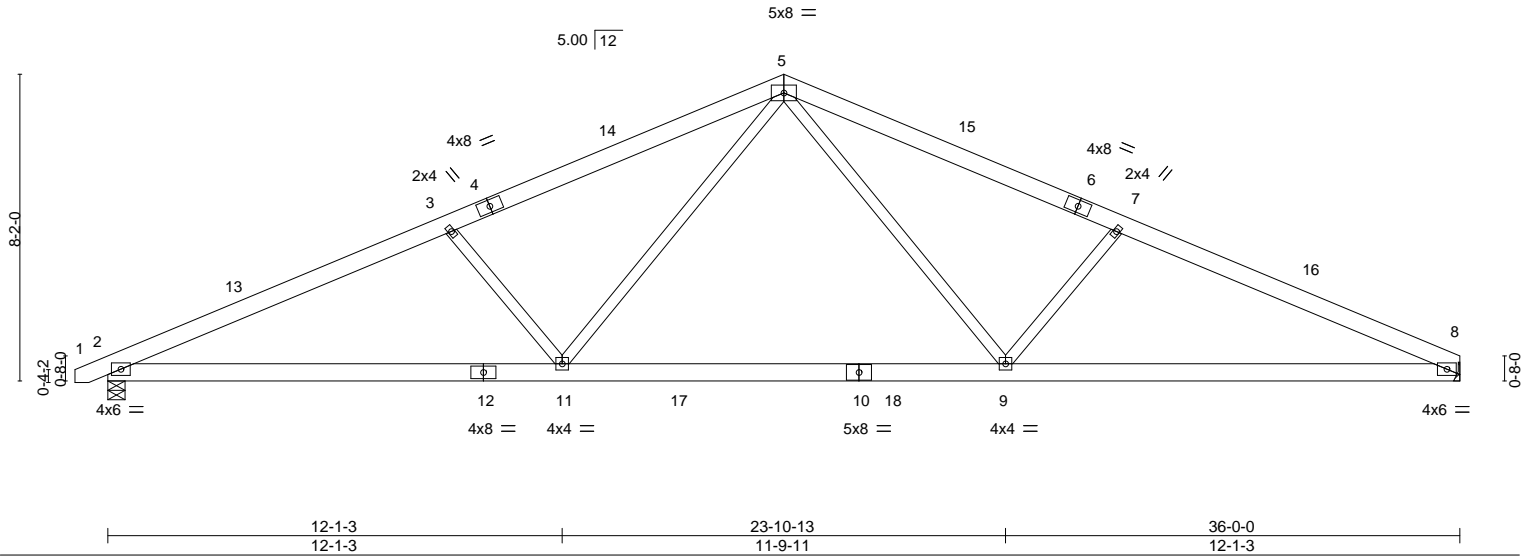

<b>LOADING</b> (psf)	<b>SPACING-</b>	<b>CSI.</b>	<b>DEFL.</b>	<b>PLATES</b>	<b>GRIP</b>
TCLL 20.0	2-0-0	TC 0.39	in (loc) l/defl L/d	MT20	244/190
TCDL 10.0	Plate Grip DOL 1.15	BC 0.62	Vert(LL) -0.33 9-11 >999 360		
BCLL 0.0 *	Lumber DOL 1.15	WB 0.23	Vert(CT) -0.46 9-11 >929 240		
BCDL 10.0	Rep Stress Incr YES	Matrix-S	Horz(CT) 0.07 8 n/a n/a		
	Code IRC2015/TPI2014		Wind(LL) 0.07 11 >999 240	Weight: 220 lb	FT = 20%

<b>LUMBER-</b>	<b>BRACING-</b>
TOP CHORD 2x6 SP No.1	TOP CHORD Structural wood sheathing directly applied or 4-1-11 oc purlins.
BOT CHORD 2x6 SP No.1	BOT CHORD Rigid ceiling directly applied or 10-0-0 oc bracing.
WEBS 2x4 SP No.2	

**REACTIONS.** (size) 2=0-5-8, 8=Mechanical  
 Max Horz 2=95(LC 16)  
 Max Uplift 2=-102(LC 12), 8=-90(LC 13)  
 Max Grav 2=1483(LC 1), 8=1427(LC 1)

**FORCES.** (lb) - Max. Comp./Max. Ten. - All forces 250 (lb) or less except when shown.  
 TOP CHORD 2-3=-2795/606, 3-5=-2523/575, 5-7=-2541/593, 7-8=-2823/631  
 BOT CHORD 2-11=-464/2490, 9-11=-207/1686, 8-9=-470/2523  
 WEBS 5-9=-120/956, 7-9=-556/311, 5-11=-115/931, 3-11=-534/302

- NOTES-**
- Unbalanced roof live loads have been considered for this design.
  - Wind: ASCE 7-10; Vult=130mph (3-second gust) Vasd=103mph; TCDL=6.0psf; BCDL=6.0psf; h=15ft; Cat. II; Exp C; Enclosed; MWFRS (envelope) and C-C Exterior(2) -0-8-5 to 3-8-8, Interior(1) 3-8-8 to 18-0-0, Exterior(2) 18-0-0 to 22-4-13, Interior(1) 22-4-13 to 35-11-0 zone; C-C for members and forces & MWFRS for reactions shown; Lumber DOL=1.60 plate grip DOL=1.60
  - This truss has been designed for a 10.0 psf bottom chord live load nonconcurrent with any other live loads.
  - \* This truss has been designed for a live load of 30.0psf on the bottom chord in all areas where a rectangle 3-6-0 tall by 2-0-0 wide will fit between the bottom chord and any other members, with BCDL = 10.0psf.
  - Refer to girder(s) for truss to truss connections.
  - Provide mechanical connection (by others) of truss to bearing plate capable of withstanding 100 lb uplift at joint(s) 8 except (jt=lb) 2=102.



December 14, 2020

Job	Truss	Truss Type	Qty	Ply	Lot 12 Pendegrift Rd.	E15207766
J0621-4088	A4	GABLE	1	1		

Comtech, Inc. Fayetteville, NC - 28314,

8.330 s Oct 7 2020 MiTek Industries, Inc. Mon Dec 14 10:48:06 2020 Page 1

ID:0iJ2hz3vp6ahZXSx7jdYHSym1hi-oEYJ4UEAFIGfUWDuPQDOZNRQ9wmUO0KLP6IFoy940t

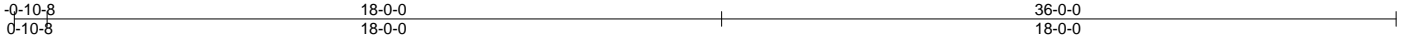

Scale = 1:61.5

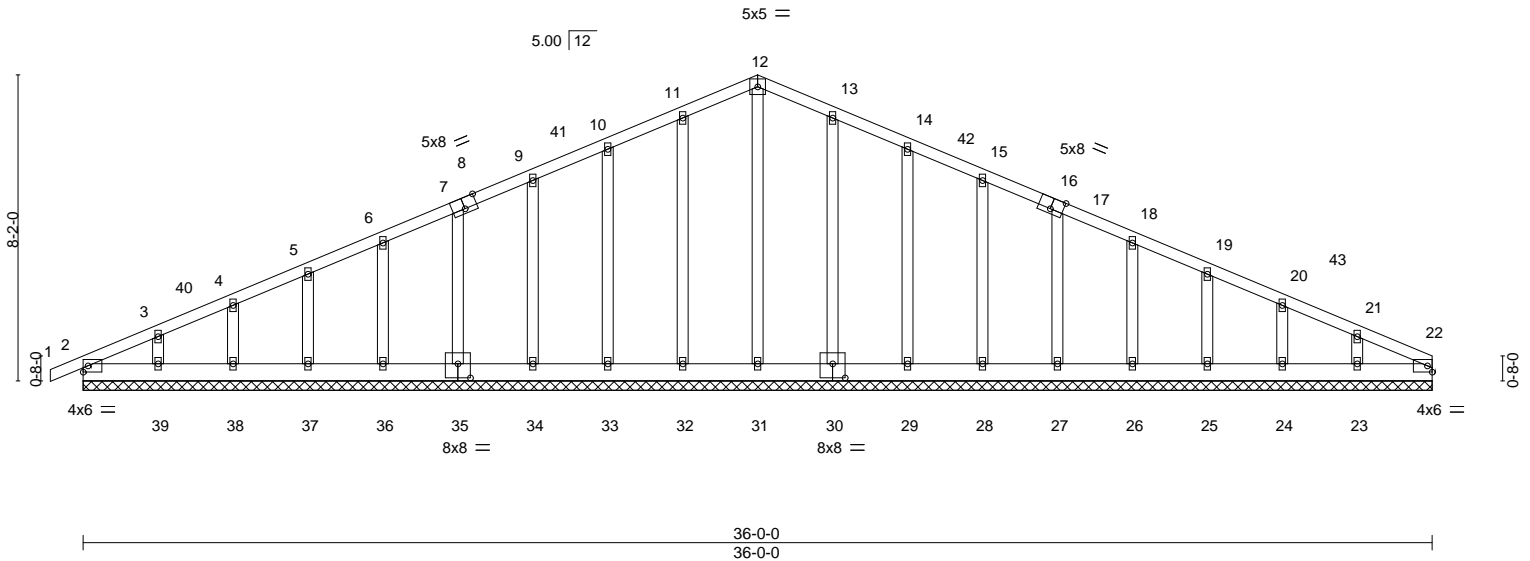

Plate Offsets (X,Y)--	[7:0-1-14,0-0-0], [8:0-4-0,Edge], [8:0-0-0,0-1-12], [16:0-4-0,Edge], [16:0-0-0,0-1-12], [17:0-1-14,0-0-0], [30:0-4-0,0-4-8], [35:0-4-0,0-4-8]
-----------------------	---

LOADING (psf)	SPACING-	CSI.	DEFL.	in (loc)	l/defl	L/d	PLATES	GRIP
TCLL 20.0	Plate Grip DOL 1.15	TC 0.06	Vert(LL) -0.00	1	n/r	120	MT20	244/190
TCDL 10.0	Lumber DOL 1.15	BC 0.02	Vert(CT) -0.00	1	n/r	120		
BCLL 0.0 *	Rep Stress Incr YES	WB 0.13	Horz(CT) 0.01	22	n/a	n/a		
BCDL 10.0	Code IRC2015/TPI2014	Matrix-S					Weight: 243 lb	FT = 20%

LUMBER-	BRACING-
TOP CHORD 2x4 SP No.1	TOP CHORD Structural wood sheathing directly applied or 6-0-0 oc purlins.
BOT CHORD 2x6 SP No.1	BOT CHORD Rigid ceiling directly applied or 10-0-0 oc bracing.
OTHERS 2x4 SP No.2	

**REACTIONS.** All bearings 36-0-0.  
 (lb) - Max Horz 2=161(LC 12)  
 Max Uplift All uplift 100 lb or less at joint(s) 2, 32, 33, 34, 35, 36, 37, 38, 39, 30, 29, 28, 27, 26, 25, 24, 23  
 Max Grav All reactions 250 lb or less at joint(s) 2, 22, 31, 32, 33, 34, 35, 36, 37, 38, 39, 30, 29, 28, 27, 26, 25, 24, 23

**FORCES.** (lb) - Max. Comp./Max. Ten. - All forces 250 (lb) or less except when shown.  
 TOP CHORD 10-11=-84/251, 11-12=-101/295, 12-13=-101/298, 13-14=-84/255

- NOTES-**
- Unbalanced roof live loads have been considered for this design.
  - Wind: ASCE 7-10; Vult=130mph (3-second gust) Vasd=103mph; TCDL=6.0psf; BCDL=6.0psf; h=15ft; Cat. II; Exp C; Enclosed; MWFRS (envelope) gable end zone and C-C Corner(3) 0-10-8 to 3-6-5, Exterior(2) 3-6-5 to 18-0-0, Corner(3) 18-0-0 to 22-4-13, Exterior(2) 22-4-13 to 36-0-0 zone;C-C for members and forces & MWFRS for reactions shown; Lumber DOL=1.60 plate grip DOL=1.60
  - Truss designed for wind loads in the plane of the truss only. For studs exposed to wind (normal to the face), see Standard Industry Gable End Details as applicable, or consult qualified building designer as per ANSI/TPI 1.
  - All plates are 2x4 MT20 unless otherwise indicated.
  - Gable requires continuous bottom chord bearing.
  - Gable studs spaced at 2-0-0 oc.
  - This truss has been designed for a 10.0 psf bottom chord live load nonconcurrent with any other live loads.
  - \* This truss has been designed for a live load of 20.0psf on the bottom chord in all areas with a clearance greater than 6-0-0 between the bottom chord and any other members, with BCDL = 10.0psf.
  - Provide mechanical connection (by others) of truss to bearing plate capable of withstanding 100 lb uplift at joint(s) 2, 32, 33, 34, 35, 36, 37, 38, 39, 30, 29, 28, 27, 26, 25, 24, 23.



December 14, 2020

**WARNING - Verify design parameters and READ NOTES ON THIS AND INCLUDED MITEK REFERENCE PAGE MII-7473 rev. 5/19/2020 BEFORE USE.**  
 Design valid for use only with MiTek® connectors. This design is based only upon parameters shown, and is for an individual building component, not a truss system. Before use, the building designer must verify the applicability of design parameters and properly incorporate this design into the overall building design. Bracing indicated is to prevent buckling of individual truss web and/or chord members only. Additional temporary and permanent bracing is always required for stability and to prevent collapse with possible personal injury and property damage. For general guidance regarding the fabrication, storage, delivery, erection and bracing of trusses and truss systems, see **ANSI/TPI1 Quality Criteria, DSB-89 and BCSI Building Component Safety Information** available from Truss Plate Institute, 2670 Crain Highway, Suite 203 Waldorf, MD 20601

**ENGINEERING BY**  
**TRENCO**  
 A MiTek Affiliate  
 818 Soundside Road  
 Edenton, NC 27932

Job	Truss	Truss Type	Qty	Ply	Lot 12 Pendegrift Rd.	E15207767
J0621-4088	B1	GABLE	1	1		

Comtech, Inc., Fayetteville, NC - 28314,

8.330 s Oct 7 2020 MiTek Industries, Inc. Mon Dec 14 10:48:08 2020 Page 1  
 ID:0iJ2hz3vp6ahZXSx7jdYHSym1hi-kcf4UAGQnwnWNjqNGXrGseoXmAycFyJRdpjbsJhy940r



4x6 =

Scale = 1:46.4

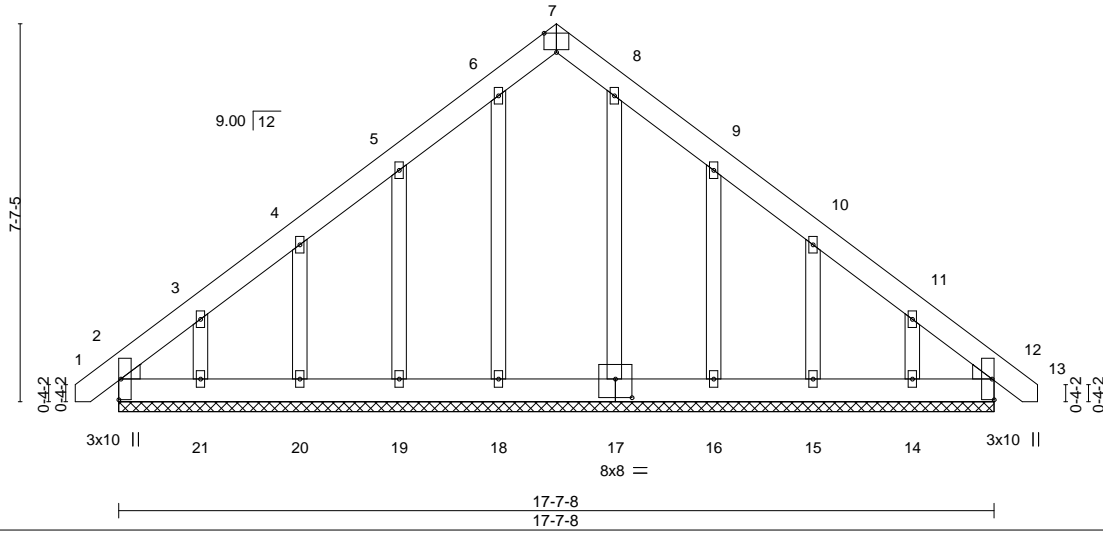

Plate Offsets (X,Y)-- [2:0-0-6,0-3-10], [2:0-0-3,0-0-4], [7:0-3-0,Edge], [12:0-0-6,0-3-10], [12:0-0-3,0-0-4], [17:0-4-0,0-4-8]

LOADING (psf)	SPACING-	CSI.	DEFL.	in (loc)	l/defl	L/d	PLATES	GRIP
TCLL 20.0	Plate Grip DOL 1.15	TC 0.04	Vert(LL) -0.00	12	n/r	120	MT20	244/190
TCDL 10.0	Lumber DOL 1.15	BC 0.02	Vert(CT) -0.00	12	n/r	120		
BCLL 0.0 *	Rep Stress Incr YES	WB 0.07	Horz(CT) 0.00	12	n/a	n/a		
BCDL 10.0	Code IRC2015/TPI2014	Matrix-S						
							Weight: 142 lb	FT = 20%

**LUMBER-**  
 TOP CHORD 2x6 SP No.1  
 BOT CHORD 2x6 SP No.1  
 OTHERS 2x4 SP No.2  
 WEDGE  
 Left: 2x4 SP No.3 , Right: 2x4 SP No.3

**BRACING-**  
 TOP CHORD Structural wood sheathing directly applied or 6-0-0 oc purlins.  
 BOT CHORD Rigid ceiling directly applied or 10-0-0 oc bracing.

**REACTIONS.** All bearings 17-7-8.  
 (lb) - Max Horz 2=171(LC 10)  
 Max Uplift All uplift 100 lb or less at joint(s) 2, 19, 20, 21, 16, 15, 14, 12  
 Max Grav All reactions 250 lb or less at joint(s) 2, 18, 19, 20, 21, 17, 16, 15, 14, 12

**FORCES.** (lb) - Max. Comp./Max. Ten. - All forces 250 (lb) or less except when shown.

- NOTES-**
- Unbalanced roof live loads have been considered for this design.
  - Wind: ASCE 7-10; Vult=130mph (3-second gust) Vasd=103mph; TCCL=6.0psf; BCDL=6.0psf; h=15ft; Cat. II; Exp C; Enclosed; MWFRS (envelope) and C-C Corner(3) 0-8-11 to 3-7-12, Exterior(2) 3-7-12 to 8-9-12, Corner(3) 8-9-12 to 13-2-9, Exterior(2) 13-2-9 to 18-4-3 zone;C-C for members and forces & MWFRS for reactions shown; Lumber DOL=1.60 plate grip DOL=1.60
  - Truss designed for wind loads in the plane of the truss only. For studs exposed to wind (normal to the face), see Standard Industry Gable End Details as applicable, or consult qualified building designer as per ANSI/TPI 1.
  - All plates are 2x4 MT20 unless otherwise indicated.
  - Gable requires continuous bottom chord bearing.
  - Gable studs spaced at 2-0-0 oc.
  - This truss has been designed for a 10.0 psf bottom chord live load nonconcurrent with any other live loads.
  - \* This truss has been designed for a live load of 20.0psf on the bottom chord in all areas with a clearance greater than 6-0-0 between the bottom chord and any other members, with BCDL = 10.0psf.
  - Provide mechanical connection (by others) of truss to bearing plate capable of withstanding 100 lb uplift at joint(s) 2, 19, 20, 21, 16, 15, 14, 12.



December 14,2020

**WARNING - Verify design parameters and READ NOTES ON THIS AND INCLUDED MITEK REFERENCE PAGE MII-7473 rev. 5/19/2020 BEFORE USE.**  
 Design valid for use only with MiTek® connectors. This design is based only upon parameters shown, and is for an individual building component, not a truss system. Before use, the building designer must verify the applicability of design parameters and properly incorporate this design into the overall building design. Bracing indicated is to prevent buckling of individual truss web and/or chord members only. Additional temporary and permanent bracing is always required for stability and to prevent collapse with possible personal injury and property damage. For general guidance regarding the fabrication, storage, delivery, erection and bracing of trusses and truss systems, see **ANSI/TPI1 Quality Criteria, DSB-89 and BCSI Building Component Safety Information** available from Truss Plate Institute, 2670 Crain Highway, Suite 203 Waldorf, MD 20601



818 Soundside Road  
 Edenton, NC 27932

Job	Truss	Truss Type	Qty	Ply	Lot 12 Pendegrift Rd.	E15207768
J0621-4088	B2	Common Girder	1	2	Job Reference (optional)	

Comtech, Inc, Fayetteville, NC - 28314,

8.330 s Oct 7 2020 MiTek Industries, Inc. Mon Dec 14 10:48:10 2020 Page 1  
 ID:0iJ2hz3vp6ahZXSx7jdYHSym1hi-g?nqvslgJXm5y8XfeGIKjDct9m8aQ6hvG14zOZy940p

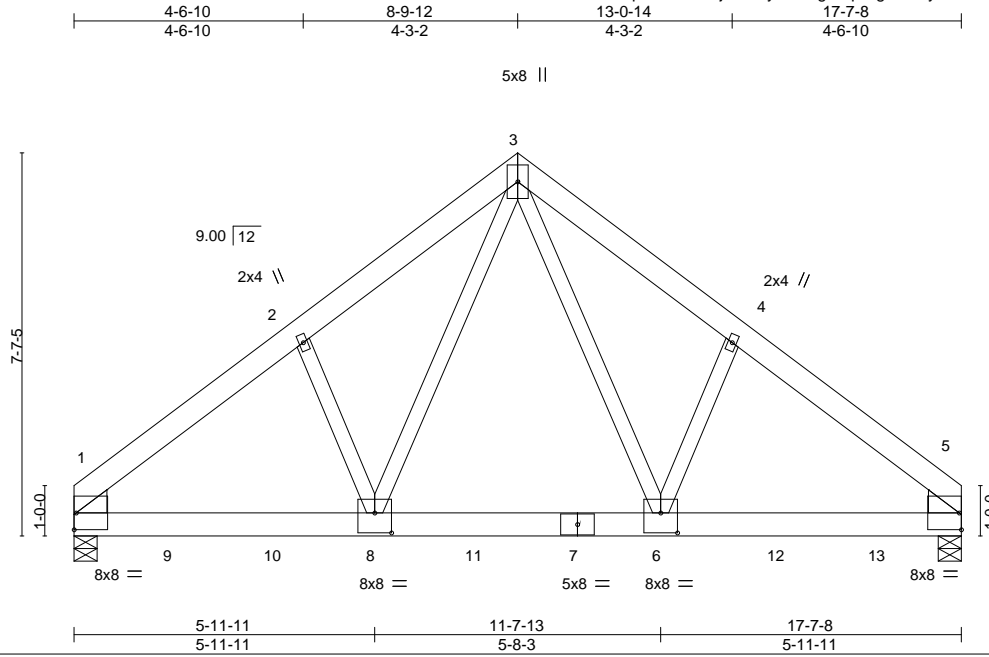

Scale = 1:45.8

Plate Offsets (X,Y)-- [1:0-0-4,0-0-3], [1:0-5-6,0-0-6], [5:0-5-6,0-0-6], [5:0-0-4,0-0-3], [6:0-4-0,0-4-12], [8:0-4-0,0-4-12]

LOADING (psf)	SPACING-	CSI.	DEFL.	in (loc)	l/defl	L/d	PLATES	GRIP
TCLL 20.0	Plate Grip DOL 1.15	TC 0.97	Vert(LL) -0.07	1-8	>999	360	MT20	244/190
TCDL 10.0	Lumber DOL 1.15	BC 0.60	Vert(CT) -0.15	1-8	>999	240		
BCLL 0.0 *	Rep Stress Incr NO	WB 0.54	Horz(CT) 0.03	5	n/a	n/a		
BCDL 10.0	Code IRC2015/TPI2014	Matrix-S	Wind(LL) 0.05	1-8	>999	240		
							Weight: 259 lb	FT = 20%

**LUMBER-**  
 TOP CHORD 2x6 SP No.1  
 BOT CHORD 2x6 SP 2400F 2.0E  
 WEBS 2x4 SP No.2  
 WEDGE  
 Left: 2x6 SP No.1 , Right: 2x6 SP No.1

**BRACING-**  
 TOP CHORD Structural wood sheathing directly applied or 5-10-11 oc purlins.  
 BOT CHORD Rigid ceiling directly applied or 10-0-0 oc bracing.

**REACTIONS.** (size) 1=0-5-8, 5=0-5-8  
 Max Horz 1=170(LC 24)  
 Max Uplift 1=-435(LC 8), 5=-444(LC 9)  
 Max Grav 1=6247(LC 1), 5=6381(LC 1)

**FORCES.** (lb) - Max. Comp./Max. Ten. - All forces 250 (lb) or less except when shown.  
 TOP CHORD 1-2=-7349/535, 2-3=-7051/598, 3-4=-7059/598, 4-5=-7357/535  
 BOT CHORD 1-8=-411/5448, 6-8=-240/3992, 5-6=-350/5454  
 WEBS 3-6=-382/4380, 4-6=-191/571, 3-8=-380/4363, 2-8=-191/571

- NOTES-**
- 2-ply truss to be connected together with 10d (0.131"x3") nails as follows:  
 Top chords connected as follows: 2x6 - 2 rows staggered at 0-9-0 oc.  
 Bottom chords connected as follows: 2x6 - 2 rows staggered at 0-6-0 oc.  
 Webs connected as follows: 2x4 - 1 row at 0-9-0 oc.
  - All loads are considered equally applied to all plies, except if noted as front (F) or back (B) face in the LOAD CASE(S) section. Ply to ply connections have been provided to distribute only loads noted as (F) or (B), unless otherwise indicated.
  - Unbalanced roof live loads have been considered for this design.
  - Wind: ASCE 7-10; Vult=130mph (3-second gust) Vasd=103mph; TCDL=6.0psf; BCDL=6.0psf; h=15ft; Cat. II; Exp C; Enclosed; MWFRS (envelope); Lumber DOL=1.60 plate grip DOL=1.60
  - This truss has been designed for a 10.0 psf bottom chord live load nonconcurrent with any other live loads.
  - \* This truss has been designed for a live load of 20.0psf on the bottom chord in all areas where a rectangle 3-6-0 tall by 2-0-0 wide will fit between the bottom chord and any other members, with BCDL = 10.0psf.
  - Provide mechanical connection (by others) of truss to bearing plate capable of withstanding 100 lb uplift at joint(s) except (jt=lb) 1=435, 5=444.
  - Hanger(s) or other connection device(s) shall be provided sufficient to support concentrated load(s) 1407 lb down and 110 lb up at 1-11-4, 1407 lb down and 110 lb up at 3-11-4, 1407 lb down and 110 lb up at 5-11-4, 1407 lb down and 110 lb up at 7-11-4, 1407 lb down and 110 lb up at 9-11-4, 1407 lb down and 110 lb up at 11-11-4, and 1407 lb down and 110 lb up at 13-11-4, and 1407 lb down and 110 lb up at 15-11-4 on bottom chord. The design/selection of such connection device(s) is the responsibility of others.

**LOAD CASE(S)** Standard  
 1) Dead + Roof Live (balanced): Lumber Increase=1.15, Plate Increase=1.15



December 14, 2020

Continued on page 2

**WARNING - Verify design parameters and READ NOTES ON THIS AND INCLUDED MITEK REFERENCE PAGE MII-7473 rev. 5/19/2020 BEFORE USE.**  
 Design valid for use only with MiTek® connectors. This design is based only upon parameters shown, and is for an individual building component, not a truss system. Before use, the building designer must verify the applicability of design parameters and properly incorporate this design into the overall building design. Bracing indicated is to prevent buckling of individual truss web and/or chord members only. Additional temporary and permanent bracing is always required for stability and to prevent collapse with possible personal injury and property damage. For general guidance regarding the fabrication, storage, delivery, erection and bracing of trusses and truss systems, see **ANSI/TPI1 Quality Criteria, DSB-89 and BCSI Building Component Safety Information** available from Truss Plate Institute, 2670 Crain Highway, Suite 203 Waldorf, MD 20601



818 Soundside Road  
 Edenton, NC 27932



Job	Truss	Truss Type	Qty	Ply	Lot 12 Pendegrift Rd.	E15207768
J0621-4088	B2	Common Girder	1	2	Job Reference (optional)	

Comtech, Inc, Fayetteville, NC - 28314,

8.330 s Oct 7 2020 MiTek Industries, Inc. Mon Dec 14 10:48:10 2020 Page 2  
 ID:0iJ2hz3vp6ahZXSx7jdYHSym1hi-g?qvslgJXm5y8XfeGIKjDct9m8aQ6hvG14zOZy940p

**LOAD CASE(S)** Standard

Uniform Loads (plf)

Vert: 1-3=-60, 3-5=-60, 1-5=-20

Concentrated Loads (lb)

Vert: 7=-1407(B) 6=-1407(B) 8=-1407(B) 9=-1407(B) 10=-1407(B) 11=-1407(B) 12=-1407(B) 13=-1407(B)

**WARNING - Verify design parameters and READ NOTES ON THIS AND INCLUDED MITEK REFERENCE PAGE MII-7473 rev. 5/19/2020 BEFORE USE.**

Design valid for use only with MiTek® connectors. This design is based only upon parameters shown, and is for an individual building component, not a truss system. Before use, the building designer must verify the applicability of design parameters and properly incorporate this design into the overall building design. Bracing indicated is to prevent buckling of individual truss web and/or chord members only. Additional temporary and permanent bracing is always required for stability and to prevent collapse with possible personal injury and property damage. For general guidance regarding the fabrication, storage, delivery, erection and bracing of trusses and truss systems, see **ANSI/TPI1 Quality Criteria, DSB-89 and BCSI Building Component Safety Information** available from Truss Plate Institute, 2670 Crain Highway, Suite 203 Waldorf, MD 20601



818 Soundside Road  
 Edenton, NC 27932

Job	Truss	Truss Type	Qty	Ply	Lot 12 Pendegrift Rd.	E15207769
J0621-4088	G01	GABLE	1	1		

Comtech, Inc. Fayetteville, NC - 28314,

8.330 s Oct 7 2020 MiTek Industries, Inc. Mon Dec 14 10:48:11 2020 Page 1

ID:0iJ2hz3vp6ahZXSx7jdYHSym1hi-8BLC7ClI4ruyaH6rCzpZGQ9HKAd09hn3VhqWw0y940o  
20-8-0 21-6-8 0-10-8

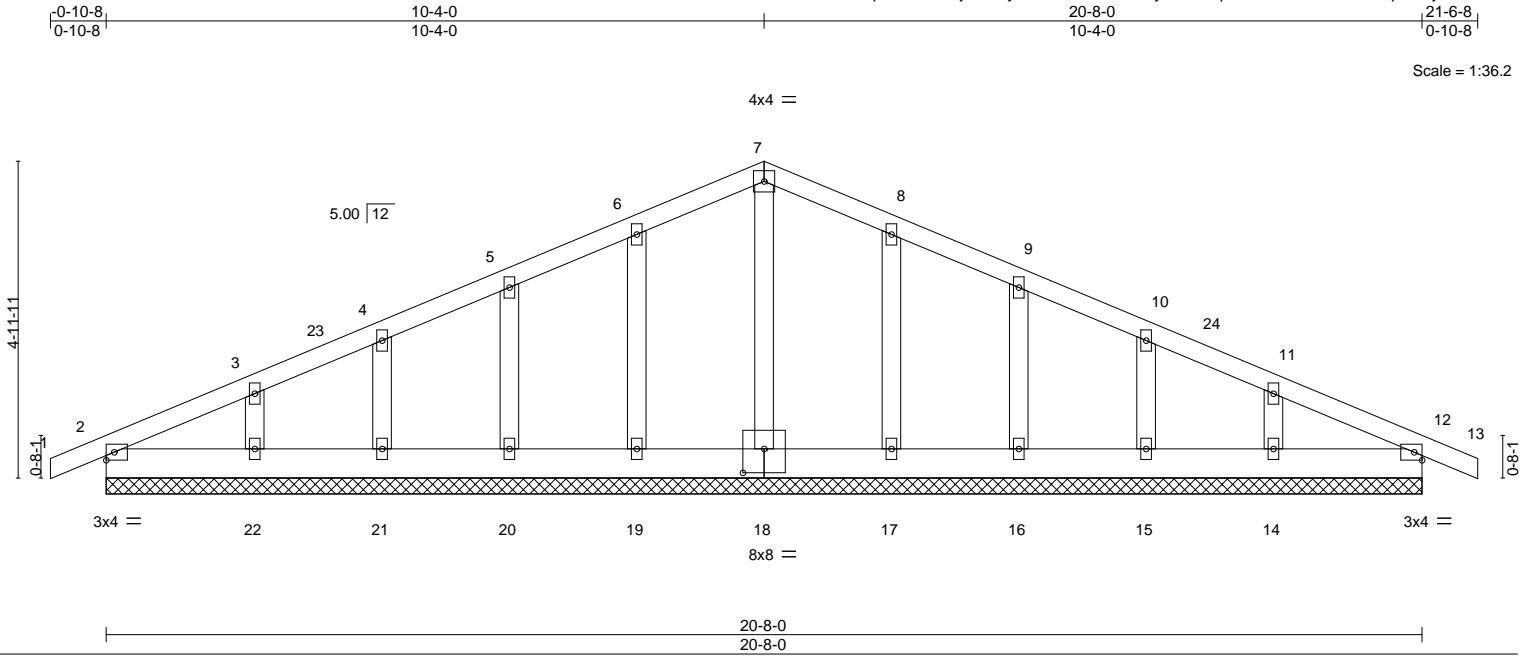

Plate Offsets (X,Y)-- [18-0-4-0-0-4-8]

LOADING (psf)	SPACING-	CSL.	DEFL.	in (loc)	l/defl	L/d	PLATES	GRIP
TCLL 20.0	Plate Grip DOL 1.15	TC 0.05	Vert(LL) -0.00	12	n/r	120	MT20	244/190
TCDL 10.0	Lumber DOL 1.15	BC 0.02	Vert(CT) -0.00	12	n/r	120		
BCLL 0.0 *	Rep Stress Incr NO	WB 0.04	Horz(CT) 0.00	12	n/a	n/a		
BCDL 10.0	Code IRC2015/TPI2014	Matrix-S						
							Weight: 117 lb	FT = 20%

**LUMBER-**  
TOP CHORD 2x4 SP No.1  
BOT CHORD 2x6 SP No.1  
OTHERS 2x4 SP No.2

**BRACING-**  
TOP CHORD Structural wood sheathing directly applied or 6-0-0 oc purlins.  
BOT CHORD Rigid ceiling directly applied or 10-0-0 oc bracing.

**REACTIONS.** All bearings 20-8-0.  
(lb) - Max Horz 2=94(LC 16)  
Max Uplift All uplift 100 lb or less at joint(s) 12, 2, 19, 20, 21, 22, 17, 16, 15, 14  
Max Grav All reactions 250 lb or less at joint(s) 12, 2, 18, 19, 20, 21, 22, 17, 16, 15, 14

**FORCES.** (lb) - Max. Comp./Max. Ten. - All forces 250 (lb) or less except when shown.

**NOTES-**

- Unbalanced roof live loads have been considered for this design.
- Wind: ASCE 7-10; Vult=130mph (3-second gust) Vasd=103mph; TCDL=6.0psf; BCDL=6.0psf; h=15ft; Cat. II; Exp C; Enclosed; MWFRS (envelope) gable end zone and C-C Exterior(2) -0-10-8 to 3-6-5, Interior(1) 3-6-5 to 10-4-0, Exterior(2) 10-4-0 to 16-4-0, Interior(1) 16-4-0 to 21-6-8 zone;C-C for members and forces & MWFRS for reactions shown; Lumber DOL=1.60 plate grip DOL=1.60
- Truss designed for wind loads in the plane of the truss only. For studs exposed to wind (normal to the face), see Standard Industry Gable End Details as applicable, or consult qualified building designer as per ANSI/TPI 1.
- All plates are 2x4 MT20 unless otherwise indicated.
- Gable requires continuous bottom chord bearing.
- Gable studs spaced at 2-0-0 oc.
- This truss has been designed for a 10.0 psf bottom chord live load nonconcurrent with any other live loads.
- \* This truss has been designed for a live load of 20.0psf on the bottom chord in all areas with a clearance greater than 6-0-0 between the bottom chord and any other members.
- Provide mechanical connection (by others) of truss to bearing plate capable of withstanding 100 lb uplift at joint(s) 12, 2, 19, 20, 21, 22, 17, 16, 15, 14.



December 14,2020

**WARNING - Verify design parameters and READ NOTES ON THIS AND INCLUDED MITEK REFERENCE PAGE MII-7473 rev. 5/19/2020 BEFORE USE.**

Design valid for use only with MiTek® connectors. This design is based only upon parameters shown, and is for an individual building component, not a truss system. Before use, the building designer must verify the applicability of design parameters and properly incorporate this design into the overall building design. Bracing indicated is to prevent buckling of individual truss web and/or chord members only. Additional temporary and permanent bracing is always required for stability and to prevent collapse with possible personal injury and property damage. For general guidance regarding the fabrication, storage, delivery, erection and bracing of trusses and truss systems, see

**ANSI/TPI1 Quality Criteria, DSB-89 and BCSI Building Component**

**Safety Information** available from Truss Plate Institute, 2670 Crain Highway, Suite 203 Waldorf, MD 20601



818 Soundside Road  
Edenton, NC 27932

Job	Truss	Truss Type	Qty	Ply	Lot 12 Pendegrift Rd.	E15207770
J0621-4088	G02	COMMON	5	1		

Comtech, Inc. Fayetteville, NC - 28314,

8.330 s Oct 7 2020 MiTek Industries, Inc. Mon Dec 14 10:48:12 2020 Page 1  
ID:0iJ2hz3vp6ahZXSx7jdYHSym1hi-cNvaKYJxr8OpCRg1mgKopehJ5Zn7u7xCkLZ3SSy940n

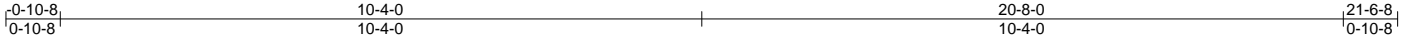

Scale = 1:37.1

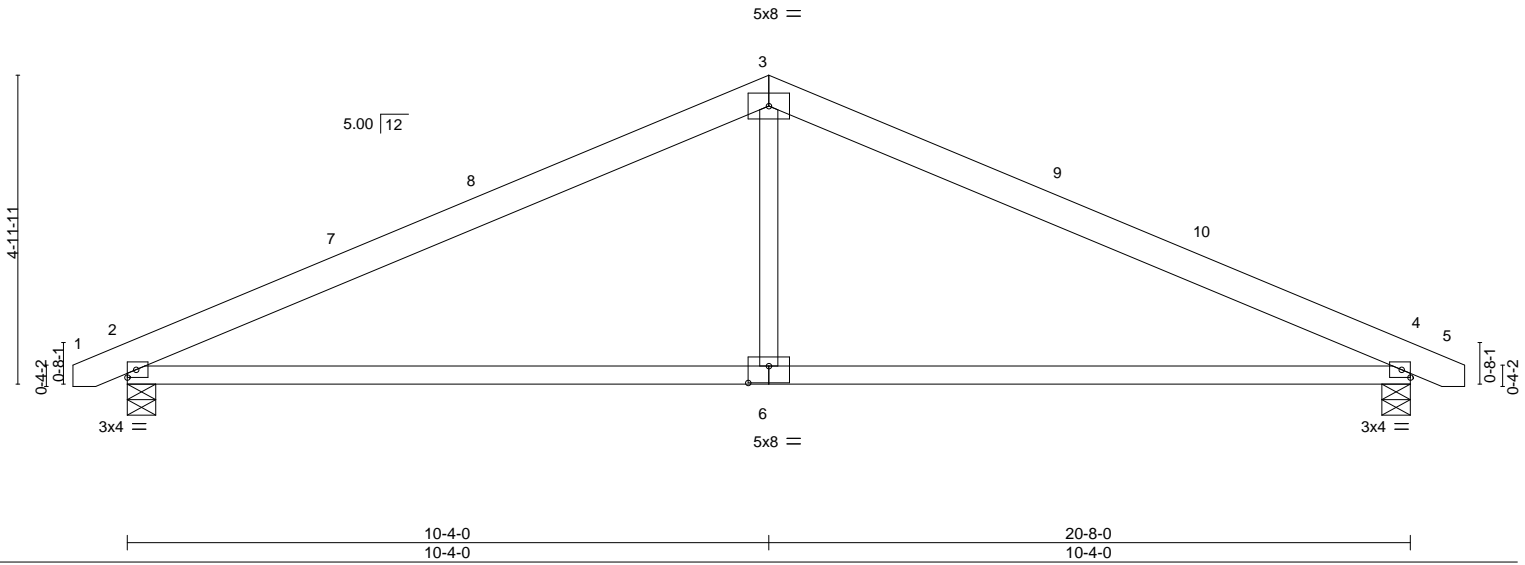

Plate Offsets (X,Y)-- [6:0-4-0,0-3-4]

LOADING (psf)	SPACING-	CSI.	DEFL.	in (loc)	l/defl	L/d	PLATES	GRIP
TCLL 20.0	Plate Grip DOL 1.15	TC 0.62	Vert(LL) -0.19	2-6	>999	360	MT20	244/190
TCDL 10.0	Lumber DOL 1.15	BC 0.79	Vert(CT) -0.40	2-6	>606	240		
BCLL 0.0 *	Rep Stress Incr YES	WB 0.11	Horz(CT) 0.03	4	n/a	n/a		
BCDL 10.0	Code IRC2015/TPI2014	Matrix-S	Wind(LL) 0.06	2-6	>999	240	Weight: 94 lb	FT = 20%

**LUMBER-**  
TOP CHORD 2x6 SP No.1  
BOT CHORD 2x4 SP No.1  
WEBS 2x4 SP No.2

**BRACING-**  
TOP CHORD Structural wood sheathing directly applied or 5-4-12 oc purlins.  
BOT CHORD Rigid ceiling directly applied or 10-0-0 oc bracing.

**REACTIONS.** (size) 4=0-5-8, 2=0-5-8  
Max Horz 2=-55(LC 13)  
Max Uplift 4=-63(LC 13), 2=-63(LC 12)  
Max Grav 4=864(LC 1), 2=864(LC 1)

**FORCES.** (lb) - Max. Comp./Max. Ten. - All forces 250 (lb) or less except when shown.  
TOP CHORD 2-3=-1216/288, 3-4=-1216/288  
BOT CHORD 2-6=-140/1030, 4-6=-140/1030  
WEBS 3-6=0/468

- NOTES-**
- Unbalanced roof live loads have been considered for this design.
  - Wind: ASCE 7-10; Vult=130mph (3-second gust) Vasd=103mph; TC DL=6.0psf; BCDL=6.0psf; h=15ft; Cat. II; Exp C; Enclosed; MWFRS (envelope) and C-C Exterior(2) -0-8-5 to 3-8-8, Interior(1) 3-8-8 to 10-4-0, Exterior(2) 10-4-0 to 14-8-13, Interior(1) 14-8-13 to 21-4-5 zone; C-C for members and forces & MWFRS for reactions shown; Lumber DOL=1.60 plate grip DOL=1.60
  - This truss has been designed for a 10.0 psf bottom chord live load nonconcurrent with any other live loads.
  - \* This truss has been designed for a live load of 20.0psf on the bottom chord in all areas with a clearance greater than 6-0-0 between the bottom chord and any other members.
  - Provide mechanical connection (by others) of truss to bearing plate capable of withstanding 100 lb uplift at joint(s) 4, 2.



December 14, 2020

**WARNING - Verify design parameters and READ NOTES ON THIS AND INCLUDED MITEK REFERENCE PAGE MII-7473 rev. 5/19/2020 BEFORE USE.**  
Design valid for use only with MiTek® connectors. This design is based only upon parameters shown, and is for an individual building component, not a truss system. Before use, the building designer must verify the applicability of design parameters and properly incorporate this design into the overall building design. Bracing indicated is to prevent buckling of individual truss web and/or chord members only. Additional temporary and permanent bracing is always required for stability and to prevent collapse with possible personal injury and property damage. For general guidance regarding the fabrication, storage, delivery, erection and bracing of trusses and truss systems, see **ANSI/TPI1 Quality Criteria, DSB-89 and BCSI Building Component Safety Information** available from Truss Plate Institute, 2670 Crain Highway, Suite 203 Waldorf, MD 20601



818 Soundside Road  
Edenton, NC 27932

Job	Truss	Truss Type	Qty	Ply	Lot 12 Pendegraft Rd.	E15207771
J0621-4088	M01	MONOPITCH SUPPORTED	2	1		

Comtech, Inc., Fayetteville, NC - 28314,

8,330 s Oct 7 2020 MiTek Industries, Inc. Mon Dec 14 10:48:13 2020 Page 1  
 ID:0iJ2hz3vp6ahZXSx7jdYHSym1hi-4aTzYtKZcS8gpbFEJOr1LrEcBzJxdbzMy?Jd?uy940m



Scale = 1:11.5

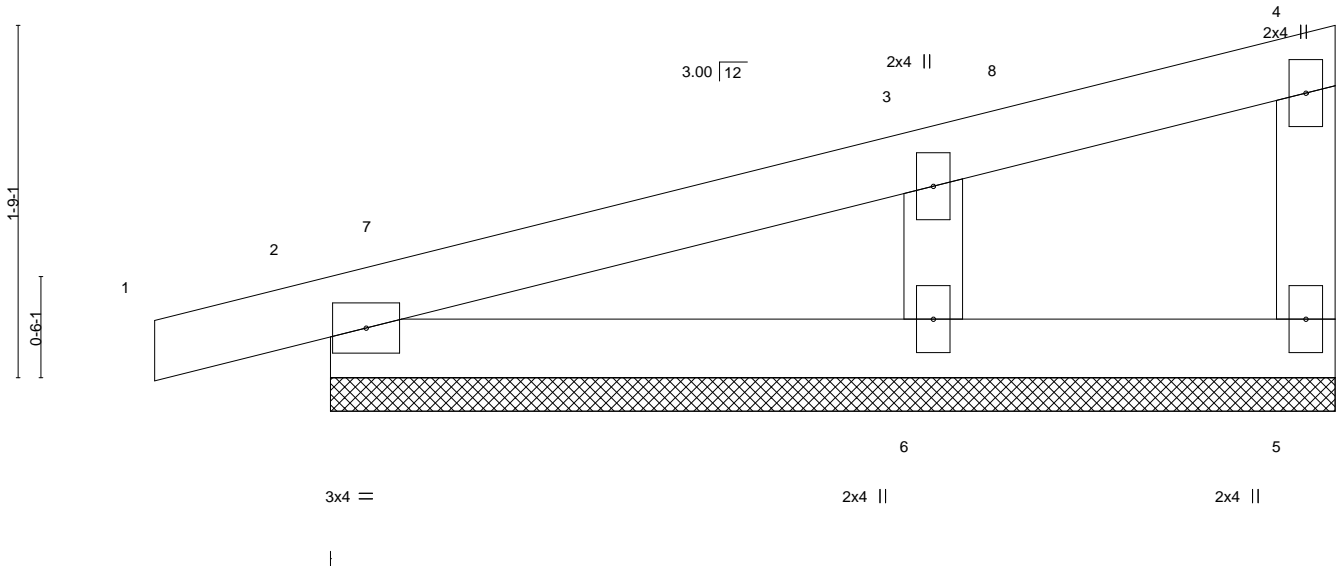

<b>LOADING</b> (psf)	<b>SPACING-</b>	<b>CSI.</b>	<b>DEFL.</b>	<b>PLATES</b>	<b>GRIP</b>
TCLL 20.0	2-0-0	TC 0.09	in (loc) l/defl L/d	MT20	244/190
TCDL 10.0	Plate Grip DOL 1.15	BC 0.05	Vert(LL) -0.00 1 n/r 120		
BCLL 0.0 *	Lumber DOL 1.15	WB 0.05	Vert(CT) 0.00 1 n/r 120		
BCDL 10.0	Rep Stress Incr YES	Matrix-P	Horz(CT) 0.00 n/a n/a	Weight: 19 lb	FT = 20%
	Code IRC2015/TPI2014				

**LUMBER-**

TOP CHORD 2x4 SP No.1  
 BOT CHORD 2x4 SP No.1  
 WEBS 2x4 SP No.2  
 OTHERS 2x4 SP No.2

**BRACING-**

TOP CHORD Structural wood sheathing directly applied or 5-0-0 oc purlins.  
 BOT CHORD Rigid ceiling directly applied or 10-0-0 oc bracing.

**REACTIONS.**

(size) 5=5-0-0, 2=5-0-0, 6=5-0-0  
 Max Horz 2=47(LC 8)  
 Max Uplift 5=-7(LC 8), 2=-37(LC 8), 6=-34(LC 12)  
 Max Grav 5=41(LC 1), 2=160(LC 1), 6=240(LC 1)

**FORCES.** (lb) - Max. Comp./Max. Ten. - All forces 250 (lb) or less except when shown.

WEBS 3-6=-176/310

**NOTES-**

- 1) Wind: ASCE 7-10; Vult=130mph (3-second gust) Vasd=103mph; TCDL=6.0psf; BCDL=6.0psf; h=15ft; Cat. II; Exp C; Enclosed; MWFRS (envelope) and C-C Corner(3) -0-10-8 to 3-6-5, Exterior(2) 3-6-5 to 4-10-4 zone; C-C for members and forces & MWFRS for reactions shown; Lumber DOL=1.60 plate grip DOL=1.60
- 2) Truss designed for wind loads in the plane of the truss only. For studs exposed to wind (normal to the face), see Standard Industry Gable End Details as applicable, or consult qualified building designer as per ANSI/TPI 1.
- 3) Gable requires continuous bottom chord bearing.
- 4) Gable studs spaced at 2-0-0 oc.
- 5) This truss has been designed for a 10.0 psf bottom chord live load nonconcurrent with any other live loads.
- 6) \* This truss has been designed for a live load of 20.0psf on the bottom chord in all areas with a clearance greater than 6-0-0 between the bottom chord and any other members.
- 7) Provide mechanical connection (by others) of truss to bearing plate capable of withstanding 100 lb uplift at joint(s) 5, 2, 6.
- 8) Beveled plate or shim required to provide full bearing surface with truss chord at joint(s) 2.



December 14, 2020

**WARNING - Verify design parameters and READ NOTES ON THIS AND INCLUDED MITEK REFERENCE PAGE MII-7473 rev. 5/19/2020 BEFORE USE.**

Design valid for use only with MiTek® connectors. This design is based only upon parameters shown, and is for an individual building component, not a truss system. Before use, the building designer must verify the applicability of design parameters and properly incorporate this design into the overall building design. Bracing indicated is to prevent buckling of individual truss web and/or chord members only. Additional temporary and permanent bracing is always required for stability and to prevent collapse with possible personal injury and property damage. For general guidance regarding the fabrication, storage, delivery, erection and bracing of trusses and truss systems, see

**ANSI/TPI1 Quality Criteria, DSB-89 and BCSI Building Component**

**Safety Information** available from Truss Plate Institute, 2670 Crain Highway, Suite 203 Waldorf, MD 20601



818 Soundside Road  
 Edenton, NC 27932

Job	Truss	Truss Type	Qty	Ply	Lot 12 Pendegrft Rd.	E15207772
J0621-4088	M02	MONOPITCH	8	1		

Comtech, Inc, Fayetteville, NC - 28314,

8.330 s Oct 7 2020 MiTek Industries, Inc. Mon Dec 14 10:48:13 2020 Page 1  
 ID:0iJ2hz3vp6ahZXSx7jdYHSym1hi-4aTzYtKZcS8gpbFEJOr1LrEZ6zGbdbPMY?Jd?uy940m



Scale = 1:11.3

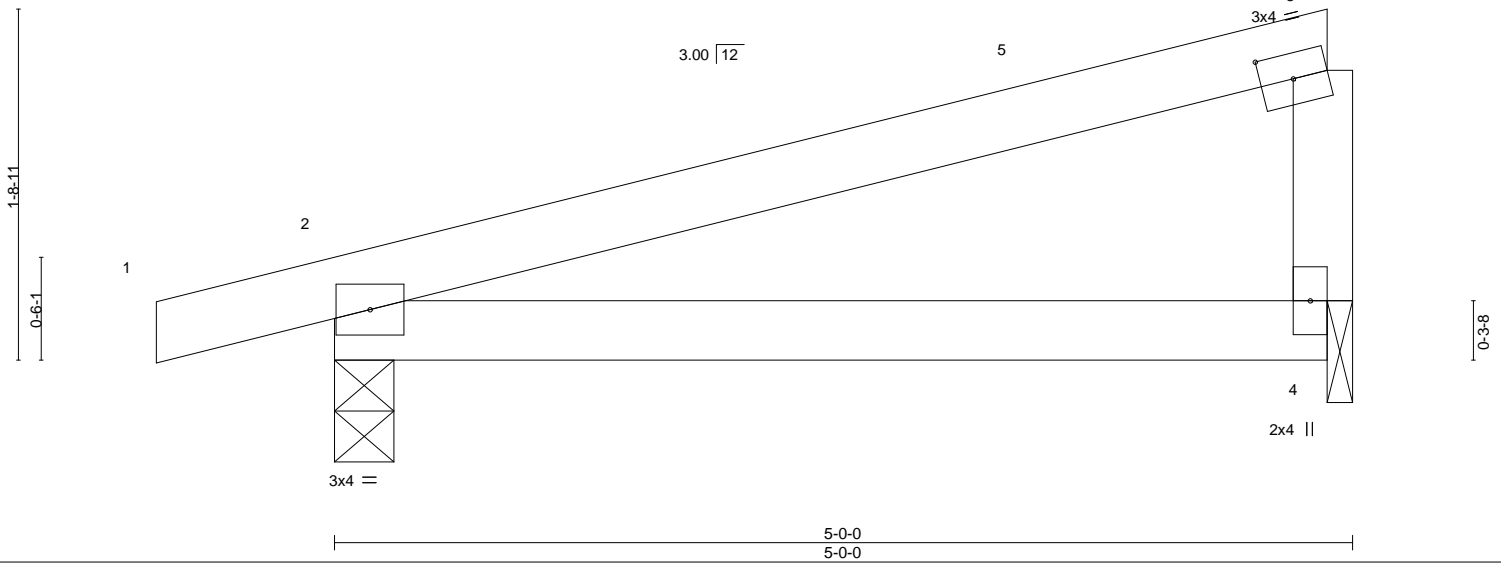

Plate Offsets (X,Y)-- [3:0-1-15,0-1-8]

LOADING (psf)	SPACING-		CSI.	DEFL.	in	(loc)	l/defl	L/d	PLATES	GRIP
TCLL 20.0	Plate Grip DOL 1.15	2-0-0	TC 0.28	Vert(LL) -0.03	2-4	>999	360		MT20	244/190
TCDL 10.0	Lumber DOL 1.15		BC 0.20	Vert(CT) -0.05	2-4	>999	240			
BCLL 0.0 *	Rep Stress Incr YES		WB 0.03	Horz(CT) 0.00	4	n/a	n/a			
BCDL 10.0	Code IRC2015/TPI2014		Matrix-P	Wind(LL) 0.00	2	****	240		Weight: 18 lb	FT = 20%

**LUMBER-**

TOP CHORD 2x4 SP No.1  
 BOT CHORD 2x4 SP No.1  
 WEBS 2x4 SP No.2

**BRACING-**

TOP CHORD Structural wood sheathing directly applied or 5-0-0 oc purlins.  
 BOT CHORD Rigid ceiling directly applied or 10-0-0 oc bracing.

**REACTIONS.**

(size) 2=0-3-8, 4=0-1-8  
 Max Horz 2=47(LC 8)  
 Max Uplift 2=-54(LC 8), 4=-25(LC 12)  
 Max Grav 2=256(LC 1), 4=181(LC 1)

**FORCES.** (lb) - Max. Comp./Max. Ten. - All forces 250 (lb) or less except when shown.

**NOTES-**

- 1) Wind: ASCE 7-10; Vult=130mph (3-second gust) Vasd=103mph; TCDL=6.0psf; BCDL=6.0psf; h=15ft; Cat. II; Exp C; Enclosed; MWFRS (envelope) and C-C Exterior(2) -0-10-8 to 3-6-5, Interior(1) 3-6-5 to 4-10-1 zone; C-C for members and forces & MWFRS for reactions shown; Lumber DOL=1.60 plate grip DOL=1.60
- 2) This truss has been designed for a 10.0 psf bottom chord live load nonconcurrent with any other live loads.
- 3) \* This truss has been designed for a live load of 20.0psf on the bottom chord in all areas with a clearance greater than 6-0-0 between the bottom chord and any other members.
- 4) Bearing at joint(s) 4 considers parallel to grain value using ANSI/TPI 1 angle to grain formula. Building designer should verify capacity of bearing surface.
- 5) Provide mechanical connection (by others) of truss to bearing plate at joint(s) 4.
- 6) Provide mechanical connection (by others) of truss to bearing plate capable of withstanding 100 lb uplift at joint(s) 2, 4.



December 14, 2020

**WARNING - Verify design parameters and READ NOTES ON THIS AND INCLUDED MITEK REFERENCE PAGE MII-7473 rev. 5/19/2020 BEFORE USE.**

Design valid for use only with MiTek® connectors. This design is based only upon parameters shown, and is for an individual building component, not a truss system. Before use, the building designer must verify the applicability of design parameters and properly incorporate this design into the overall building design. Bracing indicated is to prevent buckling of individual truss web and/or chord members only. Additional temporary and permanent bracing is always required for stability and to prevent collapse with possible personal injury and property damage. For general guidance regarding the fabrication, storage, delivery, erection and bracing of trusses and truss systems, see

**ANSI/TPI1 Quality Criteria, DSB-89 and BCSI Building Component**

**Safety Information** available from Truss Plate Institute, 2670 Crain Highway, Suite 203 Waldorf, MD 20601



818 Soundside Road  
 Edenton, NC 27932

Job	Truss	Truss Type	Qty	Ply	Lot 12 Pendegrift Rd.	E15207773
J0621-4088	P1	GABLE	2	1		

Comtech, Inc., Fayetteville, NC - 28314,

8.330 s Oct 7 2020 MiTek Industries, Inc. Mon Dec 14 10:48:14 2020 Page 1

ID:0iJ2hz3vp6ahZXSx7jdYHSym1hi-Zm1LIDLBNmGXRIqQt5NGu3mhHNZ2M2RVBF2AXLy940I

0-4-8  
0-4-8

8-0-0  
8-0-0

Scale = 1:15.7

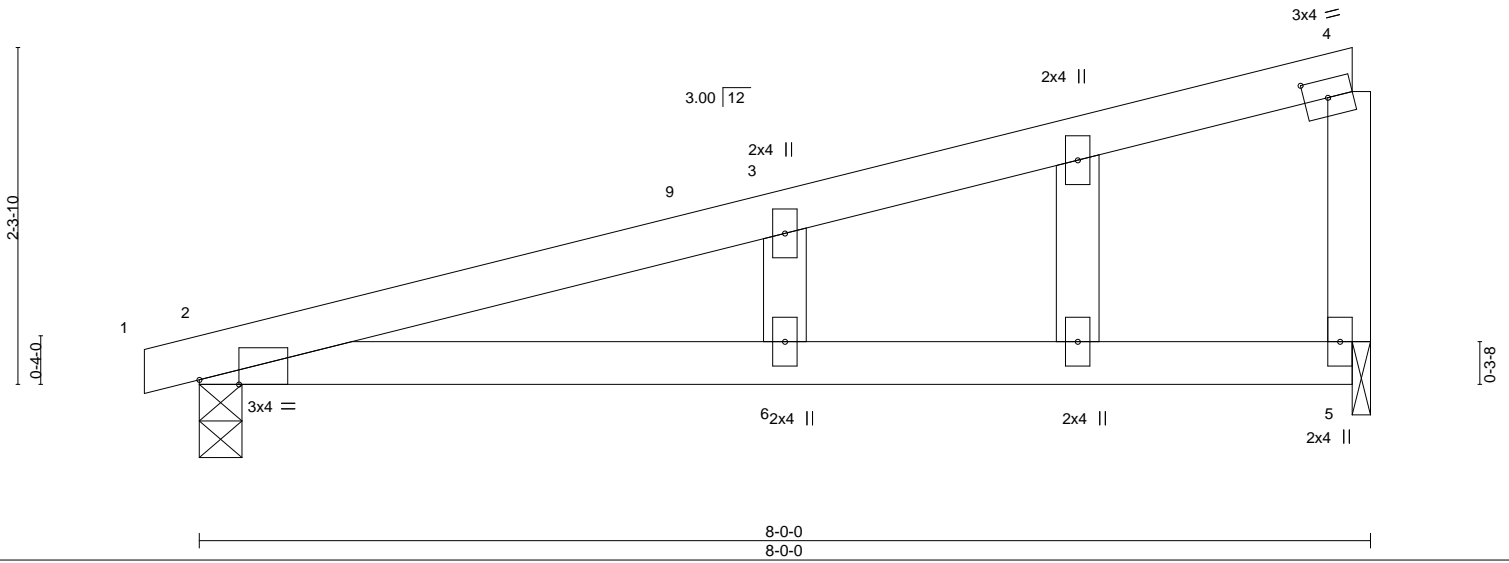

Plate Offsets (X,Y)-- [2:0-3-4, Edge], [4:0-1-15, 0-1-8]

LOADING (psf)	SPACING-	CSI.	DEFL.	in	(loc)	l/defl	L/d	PLATES	GRIP
TCLL 20.0	2-0-0	TC 0.45	Vert(LL)	-0.16	6	>562	360	MT20	244/190
TCDL 10.0	Plate Grip DOL 1.15	BC 0.44	Vert(CT)	-0.33	6	>280	240		
BCLL 0.0 *	Lumber DOL 1.15	WB 0.04	Horz(CT)	-0.00	5	n/a	n/a		
BCDL 10.0	Rep Stress Incr YES	Matrix-S	Wind(LL)	0.26	6	>354	240		
	Code IRC2015/TPI2014							Weight: 30 lb	FT = 20%

**LUMBER-**

TOP CHORD 2x4 SP No.1  
 BOT CHORD 2x4 SP 2400F 2.0E  
 WEBS 2x4 SP No.2  
 OTHERS 2x4 SP No.2

**BRACING-**

TOP CHORD Structural wood sheathing directly applied or 6-0-0 oc purlins.  
 BOT CHORD Rigid ceiling directly applied or 10-0-0 oc bracing.

**REACTIONS.**

(size) 2=0-3-8, 5=0-1-8  
 Max Horz 2=97(LC 8)  
 Max Uplift 2=-103(LC 8), 5=-99(LC 12)  
 Max Grav 2=341(LC 1), 5=306(LC 1)

**FORCES.** (lb) - Max. Comp./Max. Ten. - All forces 250 (lb) or less except when shown.

**NOTES-**

- 1) Wind: ASCE 7-10; Vult=130mph (3-second gust) Vasd=103mph; TCDL=6.0psf; BCDL=6.0psf; h=15ft; Cat. II; Exp C; Enclosed; MWFRS (envelope) gable end zone and C-C Corner(3) 0-4-8 to 4-0-0, Exterior(2) 4-0-0 to 7-10-1 zone; C-C for members and forces & MWFRS for reactions shown; Lumber DOL=1.60 plate grip DOL=1.60
- 2) Truss designed for wind loads in the plane of the truss only. For studs exposed to wind (normal to the face), see Standard Industry Gable End Details as applicable, or consult qualified building designer as per ANSI/TPI 1.
- 3) Gable studs spaced at 2-0-0 oc.
- 4) This truss has been designed for a 10.0 psf bottom chord live load nonconcurrent with any other live loads.
- 5) \* This truss has been designed for a live load of 20.0psf on the bottom chord in all areas with a clearance greater than 6-0-0 between the bottom chord and any other members.
- 6) Bearing at joint(s) 5 considers parallel to grain value using ANSI/TPI 1 angle to grain formula. Building designer should verify capacity of bearing surface.
- 7) Provide mechanical connection (by others) of truss to bearing plate at joint(s) 5.
- 8) Provide mechanical connection (by others) of truss to bearing plate capable of withstanding 100 lb uplift at joint(s) 5 except (jt=lb) 2=103.



December 14, 2020

**WARNING - Verify design parameters and READ NOTES ON THIS AND INCLUDED MITEK REFERENCE PAGE MII-7473 rev. 5/19/2020 BEFORE USE.**

Design valid for use only with MiTek® connectors. This design is based only upon parameters shown, and is for an individual building component, not a truss system. Before use, the building designer must verify the applicability of design parameters and properly incorporate this design into the overall building design. Bracing indicated is to prevent buckling of individual truss web and/or chord members only. Additional temporary and permanent bracing is always required for stability and to prevent collapse with possible personal injury and property damage. For general guidance regarding the fabrication, storage, delivery, erection and bracing of trusses and truss systems, see

**ANSI/TPI1 Quality Criteria, DSB-89 and BCSI Building Component**

**Safety Information** available from Truss Plate Institute, 2670 Crain Highway, Suite 203 Waldorf, MD 20601



818 Soundside Road  
 Edenton, NC 27932

Job J0621-4088	Truss P2	Truss Type MONOPITCH	Qty 6	Ply 1	Lot 12 Pendegrift Rd. Job Reference (optional)	E15207774
-------------------	-------------	-------------------------	----------	----------	---	-----------

Comtech, Inc, Fayetteville, NC - 28314,

8.330 s Oct 7 2020 MiTek Industries, Inc. Mon Dec 14 10:48:15 2020 Page 1

ID:0iJ2hz3vp6ahZXSx7jdYHSym1hi-1ybjyZLp83OO3vPcRpuVQGJlwnvV5VmeQJok3ny940k

-0-4-8  
0-4-8

8-0-0  
8-0-0

Scale = 1:15.7

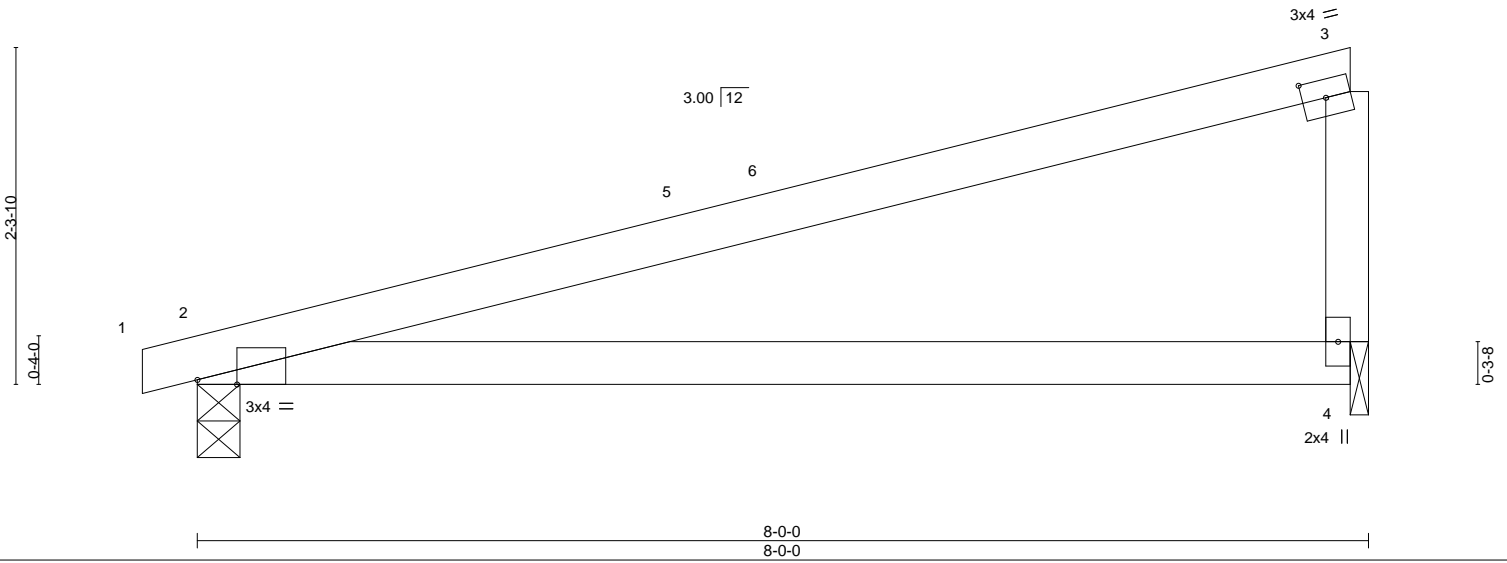

Plate Offsets (X,Y)-- [2:0-3-4,Edge], [3:0-1-15,0-1-8]

LOADING (psf)	SPACING-	2-0-0	CSI.	DEFL.	in	(loc)	l/defl	L/d	PLATES	GRIP
TCLL 20.0	Plate Grip DOL	1.15	TC 0.90	Vert(LL)	-0.15	2-4	>624	360	MT20	244/190
TCDL 10.0	Lumber DOL	1.15	BC 0.36	Vert(CT)	-0.30	2-4	>312	240		
BCLL 0.0 *	Rep Stress Incr	YES	WB 0.04	Horz(CT)	0.00	4	n/a	n/a		
BCDL 10.0	Code	IRC2015/TPI2014	Matrix-P	Wind(LL)	0.32	2-4	>285	240	Weight: 27 lb	FT = 20%

**LUMBER-**

TOP CHORD 2x4 SP No.1  
BOT CHORD 2x4 SP 2400F 2.0E  
WEBS 2x4 SP No.2

**BRACING-**

TOP CHORD Structural wood sheathing directly applied or 2-2-0 oc purlins.  
BOT CHORD Rigid ceiling directly applied or 10-0-0 oc bracing.

**REACTIONS.**

(size) 2=0-3-8, 4=0-1-8  
Max Horz 2=68(LC 8)  
Max Uplift 2=-130(LC 8), 4=-126(LC 8)  
Max Grav 2=341(LC 1), 4=306(LC 1)

**FORCES.** (lb) - Max. Comp./Max. Ten. - All forces 250 (lb) or less except when shown.

**NOTES-**

- 1) Wind: ASCE 7-10; Vult=130mph (3-second gust) Vasd=103mph; TCDL=6.0psf; BCDL=6.0psf; h=15ft; Cat. II; Exp C; Enclosed; MWFRS (envelope) and C-C Exterior(2) -0-4-8 to 4-0-5, Interior(1) 4-0-5 to 7-10-1 zone; porch left exposed;C-C for members and forces & MWFRS for reactions shown; Lumber DOL=1.60 plate grip DOL=1.60
- 2) This truss has been designed for a 10.0 psf bottom chord live load nonconcurrent with any other live loads.
- 3) \* This truss has been designed for a live load of 20.0psf on the bottom chord in all areas with a clearance greater than 6-0-0 between the bottom chord and any other members.
- 4) Bearing at joint(s) 4 considers parallel to grain value using ANSI/TPI 1 angle to grain formula. Building designer should verify capacity of bearing surface.
- 5) Provide mechanical connection (by others) of truss to bearing plate at joint(s) 4.
- 6) Provide mechanical connection (by others) of truss to bearing plate capable of withstanding 100 lb uplift at joint(s) except (jt=lb) 2=130, 4=126.



December 14, 2020

**WARNING - Verify design parameters and READ NOTES ON THIS AND INCLUDED MITEK REFERENCE PAGE MII-7473 rev. 5/19/2020 BEFORE USE.**

Design valid for use only with MiTek® connectors. This design is based only upon parameters shown, and is for an individual building component, not a truss system. Before use, the building designer must verify the applicability of design parameters and properly incorporate this design into the overall building design. Bracing indicated is to prevent buckling of individual truss web and/or chord members only. Additional temporary and permanent bracing is always required for stability and to prevent collapse with possible personal injury and property damage. For general guidance regarding the fabrication, storage, delivery, erection and bracing of trusses and truss systems, see

**ANSI/TPI1 Quality Criteria, DSB-89 and BCSI Building Component**

**Safety Information** available from Truss Plate Institute, 2670 Crain Highway, Suite 203 Waldorf, MD 20601



818 Soundside Road  
Edenton, NC 27932

# Symbols

## PLATE LOCATION AND ORIENTATION

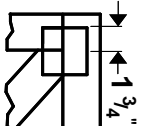

Center plate on joint unless x, y offsets are indicated. Dimensions are in ft-in-sixteenths. Apply plates to both sides of truss and fully embed teeth.

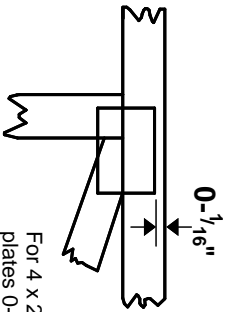

For 4 x 2 orientation, locate plates 0- 1/16" from outside edge of truss.



This symbol indicates the required direction of slots in connector plates.

\* Plate location details available in **MITek 20/20 software** or upon request.

## PLATE SIZE

**4 X 4**

The first dimension is the plate width measured perpendicular to slots. Second dimension is the length parallel to slots.

## LATERAL BRACING LOCATION



Indicated by symbol shown and/or by text in the bracing section of the output. Use T or I bracing if indicated.

## BEARING



Indicates location where bearings (supports) occur. Icons vary but reaction section indicates joint number where bearings occur. Min size shown is for crushing only.

### Industry Standards:

ANSI/TPI 1: National Design Specification for Metal Plate Connected Wood Truss Construction.  
DSB-89: Design Standard for Bracing, Building Component Safety Information, Guide to Good Practice for Handling, Installing & Bracing of Metal Plate Connected Wood Trusses.

# Numbering System

6-4-8  
dimensions shown in ft-in-sixteenths  
(Drawings not to scale)

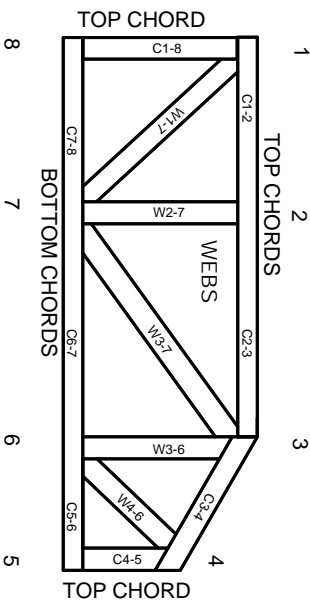

**JOINTS ARE GENERALLY NUMBERED/LETTERED CLOCKWISE AROUND THE TRUSS STARTING AT THE JOINT FARTHEST TO THE LEFT.**

**CHORDS AND WEBS ARE IDENTIFIED BY END JOINT NUMBERS/LETTERS.**

## PRODUCT CODE APPROVALS

ICC-ES Reports:

ESR-1311, ESR-1352, ESR1988  
ER-3907, ESR-2362, ESR-1397, ESR-3282

Trusses are designed for wind loads in the plane of the truss unless otherwise shown.

Lumber design values are in accordance with ANSI/TPI 1 section 6.3 These truss designs rely on lumber values established by others.

© 2012 MITteK® All Rights Reserved



MITek Engineering Reference Sheet: MI1-7473 rev. 5/19/2020



# General Safety Notes

## Failure to Follow Could Cause Property Damage or Personal Injury

1. Additional stability bracing for truss system, e.g. diagonal or X-bracing, is always required. See BCSI.
2. Truss bracing must be designed by an engineer. For wide truss spacing, individual lateral braces themselves may require bracing, or alternative Tor I bracing should be considered.
3. Never exceed the design loading shown and never stack materials on inadequately braced trusses.
4. Provide copies of this truss design to the building designer, erection supervisor, property owner and all other interested parties.
5. Cut members to bear tightly against each other.
6. Place plates on each face of truss at each joint and embed fully. Knots and wane at joint locations are regulated by ANSI/TPI 1.
7. Design assumes trusses will be suitably protected from the environment in accord with ANSI/TPI 1.
8. Unless otherwise noted, moisture content of lumber shall not exceed 19% at time of fabrication.
9. Unless expressly noted, this design is not applicable for use with fire retardant, preservative treated, or green lumber.
10. Camber is a non-structural consideration and is the responsibility of truss fabricator. General practice is to camber for dead load deflection.
11. Plate type, size, orientation and location dimensions indicated are minimum plating requirements.
12. Lumber used shall be of the species and size, and in all respects, equal to or better than that specified.
13. Top chords must be sheathed or purlins provided at spacing indicated on design.
14. Bottom chords require lateral bracing at 10 ft. spacing, or less, if no ceiling is installed, unless otherwise noted.
15. Connections not shown are the responsibility of others.
16. Do not cut or alter truss member or plate without prior approval of an engineer.
17. Install and load vertically unless indicated otherwise.
18. Use of green or treated lumber may pose unacceptable environmental, health or performance risks. Consult with project engineer before use.
19. Review all portions of this design (front, back, words and pictures) before use. Rewriting pictures alone is not sufficient.
20. Design assumes manufacture in accordance with ANSI/TPI 1 Quality Criteria.
21. The design does not take into account any dynamic or other loads other than those expressly stated.