

RE: J0621-4013
 Lot 10 Pendegraff Rd.

Trenco
 818 Soundside Rd
 Edenton, NC 27932

Site Information:

Customer: Project Name: J0621-4013
 Lot/Block: Model:
 Address: Subdivision:
 City: State:

General Truss Engineering Criteria & Design Loads (Individual Truss Design Drawings Show Special Loading Conditions):

Design Code: IRC2015/TPI2014 Design Program: MiTek 20/20 8.3
 Wind Code: ASCE 7-10 Wind Speed: 130 mph
 Roof Load: 40.0 psf Floor Load: N/A psf

This package includes 13 individual, dated Truss Design Drawings and 0 Additional Drawings.

No.	Seal#	Truss Name	Date
1	E15364184	A1	6/24/2021
2	E15364185	A2	6/24/2021
3	E15364186	A2-P	6/24/2021
4	E15364187	A3	6/24/2021
5	E15364188	A4	6/24/2021
6	E15364189	B1	6/24/2021
7	E15364190	B2	6/24/2021
8	E15364191	G01	6/24/2021
9	E15364192	G02	6/24/2021
10	E15364193	M01	6/24/2021
11	E15364194	M02	6/24/2021
12	E15364195	P1	6/24/2021
13	E15364196	P2	6/24/2021

The truss drawing(s) referenced above have been prepared by Truss Engineering Co. under my direct supervision based on the parameters provided by Comtech, Inc - Fayetteville.

Truss Design Engineer's Name: Gilbert, Eric

My license renewal date for the state of North Carolina is December 31, 2021.

North Carolina COA: C-0844

IMPORTANT NOTE: The seal on these truss component designs is a certification that the engineer named is licensed in the jurisdiction(s) identified and that the designs comply with ANSI/TPI 1. These designs are based upon parameters shown (e.g., loads, supports, dimensions, shapes and design codes), which were given to TRENCO. Any project specific information included is for TRENCO customers file reference purpose only, and was not taken into account in the preparation of these designs. TRENCO has not independently verified the applicability of the design parameters or the designs for any particular building. Before use, the building designer should verify applicability of design parameters and properly incorporate these designs into the overall building design per ANSI/TPI 1, Chapter 2.



June 24, 2021

Job	Truss	Truss Type	Qty	Ply	Lot 10 Pendegrft Rd.	E15364184
J0621-4013	A1	GABLE	1	1		

Comtech, Inc, Fayetteville, NC - 28314,

8.330 s Oct 7 2020 MiTek Industries, Inc. Sun Jan 31 13:50:28 2021 Page 1

ID:0iJ2hz3vp6ahZXSx7jdYHSym1hi-JNH7dos7ZIEq1nWsJGoSyTRAlivVX64v1?2rX6zppjv

-0-10-8 18-0-0 36-0-0 36-10-8
 0-10-8 18-0-0 18-0-0 0-10-8

Scale = 1:61.3

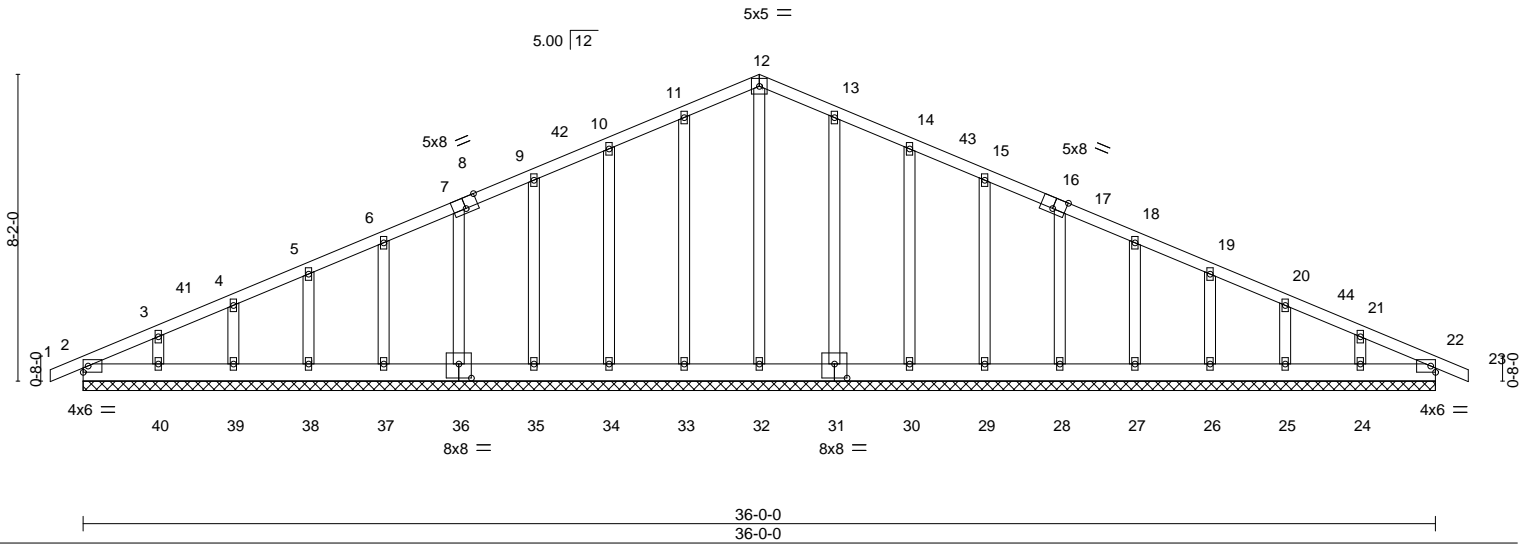

Plate Offsets (X,Y)-- [7:0-1-14,0-0-0], [8:0-4-0,Edge], [8:0-0-0,0-1-12], [16:0-4-0,Edge], [16:0-0-0,0-1-12], [17:0-1-14,0-0-0], [31:0-4-0,0-4-8], [36:0-4-0,0-4-8]

LOADING (psf)	SPACING-	CSL	DEFL.	in (loc)	l/defl	L/d	PLATES	GRIP
TCLL 20.0	Plate Grip DOL 1.15	TC 0.06	Vert(LL) -0.00	22	n/r	120	MT20	244/190
TCDL 10.0	Lumber DOL 1.15	BC 0.02	Vert(CT) -0.00	22	n/r	120		
BCLL 0.0 *	Rep Stress Incr YES	WB 0.13	Horz(CT) 0.01	22	n/a	n/a		
BCDL 10.0	Code IRC2015/TPI2014	Matrix-S					Weight: 244 lb	FT = 20%

LUMBER-	BRACING-
TOP CHORD 2x4 SP No.1	TOP CHORD Structural wood sheathing directly applied or 6-0-0 oc purlins.
BOT CHORD 2x6 SP No.1	BOT CHORD Rigid ceiling directly applied or 10-0-0 oc bracing.
OTHERS 2x4 SP No.2	

REACTIONS. All bearings 36-0-0.
 (lb) - Max Horz 2=159(LC 17)
 Max Uplift All uplift 100 lb or less at joint(s) 2, 22, 33, 34, 35, 36, 37, 38, 39, 40, 31, 30, 29, 28, 27, 26, 25, 24
 Max Grav All reactions 250 lb or less at joint(s) 2, 22, 32, 33, 34, 35, 36, 37, 38, 39, 40, 31, 30, 29, 28, 27, 26, 25, 24

FORCES. (lb) - Max. Comp./Max. Ten. - All forces 250 (lb) or less except when shown.
 TOP CHORD 10-11=-85/252, 11-12=-101/296, 12-13=-101/296, 13-14=-85/253

- NOTES-**
- Unbalanced roof live loads have been considered for this design.
 - Wind: ASCE 7-10; Vult=130mph (3-second gust) Vasd=103mph; TCDL=6.0psf; BCDL=6.0psf; h=15ft; Cat. II; Exp C; Enclosed; MWFRS (envelope) gable end zone and C-C Corner(3) -0-10-8 to 3-6-5, Exterior(2) 3-6-5 to 18-0-0, Corner(3) 18-0-0 to 22-4-13, Exterior(2) 22-4-13 to 36-10-8 zone; C-C for members and forces & MWFRS for reactions shown; Lumber DOL=1.60 plate grip DOL=1.60
 - Truss designed for wind loads in the plane of the truss only. For studs exposed to wind (normal to the face), see Standard Industry Gable End Details as applicable, or consult qualified building designer as per ANSI/TPI 1.
 - All plates are 2x4 MT20 unless otherwise indicated.
 - Gable requires continuous bottom chord bearing.
 - Gable studs spaced at 2-0-0 oc.
 - This truss has been designed for a 10.0 psf bottom chord live load nonconcurrent with any other live loads.
 - * This truss has been designed for a live load of 20.0psf on the bottom chord in all areas with a clearance greater than 6-0-0 between the bottom chord and any other members, with BCDL = 10.0psf.
 - Provide mechanical connection (by others) of truss to bearing plate capable of withstanding 100 lb uplift at joint(s) 2, 22, 33, 34, 35, 36, 37, 38, 39, 40, 31, 30, 29, 28, 27, 26, 25, 24.

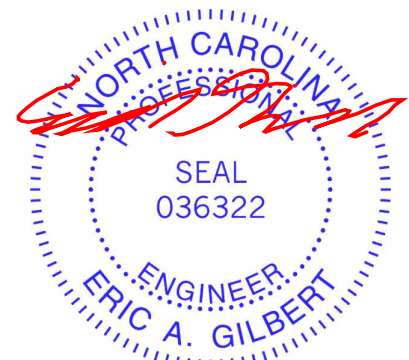

February 1, 2021

Job	Truss	Truss Type	Qty	Ply	Lot 10 Pendegrft Rd.	E15364185
J0621-4013	A2	COMMON	4	1		

Comtech, Inc., Fayetteville, NC - 28314,

8.330 s Oct 7 2020 MiTek Industries, Inc. Sun Jan 31 13:50:29 2021 Page 1

ID:0iJ2hz3vp6ahZXSx7jdYHSym1hi-naqVq8tIKzMhfx53tzJhUhzGu64DGyc2GfnO3Zzppju

0-10-8 9-1-12 18-0-0 26-10-4 36-0-0 36-10-8
 0-10-8 9-1-12 8-10-4 8-10-4 9-1-12 0-10-8

Scale = 1:62.5

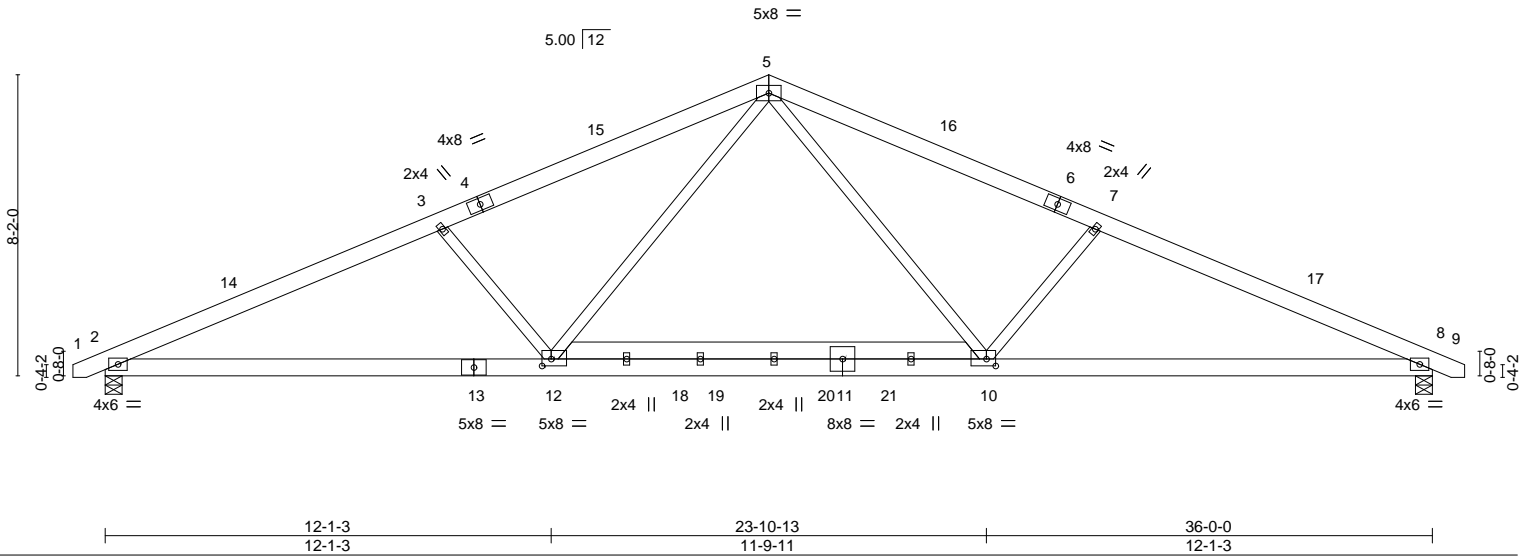

Plate Offsets (X,Y)-- [10:0-3-0,0-2-4], [12:0-3-0,0-2-4]

LOADING (psf)	SPACING-	CSI.	DEFL.	in (loc)	l/defl	L/d	PLATES	GRIP
TCLL 20.0	Plate Grip DOL 1.15	TC 0.35	Vert(LL) -0.22	10-12	>999	360	MT20	244/190
TCDL 10.0	Lumber DOL 1.15	BC 0.75	Vert(CT) -0.55	10-12	>780	240		
BCLL 0.0 *	Rep Stress Incr YES	WB 0.24	Horz(CT) 0.08	8	n/a	n/a		
BCDL 10.0	Code IRC2015/TPI2014	Matrix-S	Wind(LL) 0.07	2-12	>999	240		
							Weight: 248 lb	FT = 20%

LUMBER-
 TOP CHORD 2x6 SP No.1
 BOT CHORD 2x6 SP No.1
 WEBS 2x4 SP No.2 *Except*
 10-12: 2x6 SP No.1

BRACING-
 TOP CHORD Structural wood sheathing directly applied or 4-1-3 oc purlins.
 BOT CHORD Rigid ceiling directly applied or 10-0-0 oc bracing.

REACTIONS. (size) 2=0-5-8, 8=0-5-8
 Max Horz 2=-93(LC 13)
 Max Uplift 2=-2(LC 12), 8=-2(LC 13)
 Max Grav 2=1577(LC 1), 8=1577(LC 1)

FORCES. (lb) - Max. Comp./Max. Ten. - All forces 250 (lb) or less except when shown.
 TOP CHORD 2-3=-3053/329, 3-5=-2733/293, 5-7=-2733/293, 7-8=-3053/329
 BOT CHORD 2-12=-205/2722, 10-12=-21/1832, 8-10=-206/2722
 WEBS 5-10=0/993, 7-10=-518/317, 5-12=0/993, 3-12=-518/317

- NOTES-**
- Unbalanced roof live loads have been considered for this design.
 - Wind: ASCE 7-10; Vult=130mph (3-second gust) Vasd=103mph; TC DL=6.0psf; BCDL=6.0psf; h=15ft; Cat. II; Exp C; Enclosed; MWFRS (envelope) and C-C Exterior(2) -0-8-5 to 3-8-8, Interior(1) 3-8-8 to 18-0-0, Exterior(2) 18-0-0 to 22-4-13, Interior(1) 22-4-13 to 36-8-5 zone:C-C for members and forces & MWFRS for reactions shown; Lumber DOL=1.60 plate grip DOL=1.60
 - 200.0lb AC unit load placed on the bottom chord, 18-0-0 from left end, supported at two points, 3-0-0 apart.
 - This truss has been designed for a 10.0 psf bottom chord live load nonconcurrent with any other live loads.
 - * This truss has been designed for a live load of 20.0psf on the bottom chord in all areas where a rectangle 3-6-0 tall by 2-0-0 wide will fit between the bottom chord and any other members, with BCDL = 10.0psf.
 - Provide mechanical connection (by others) of truss to bearing plate capable of withstanding 100 lb uplift at joint(s) 2, 8.

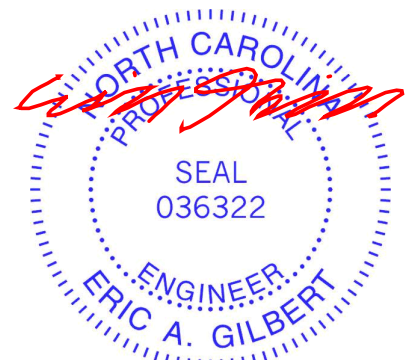

February 1, 2021

Job	Truss	Truss Type	Qty	Ply	Lot 10 Pendegrift Rd.	E15364186
J0621-4013	A2-P	COMMON	2	1		

Comtech, Inc., Fayetteville, NC - 28314,

8.330 s Oct 7 2020 MiTek Industries, Inc. Sun Jan 31 13:50:30 2021 Page 1

ID:0iJ2hz3vp6ahZXSx7jdYHSym1hi-FmOu2Tn5HUYG5fFRhqw1uWQMWNm?_eCUJXyb?zppjt

0-10-8 9-1-12 18-0-0 26-10-4 36-0-0 36-10-8
 0-10-8 9-1-12 8-10-4 8-10-4 9-1-12 0-10-8

Scale = 1:62.5

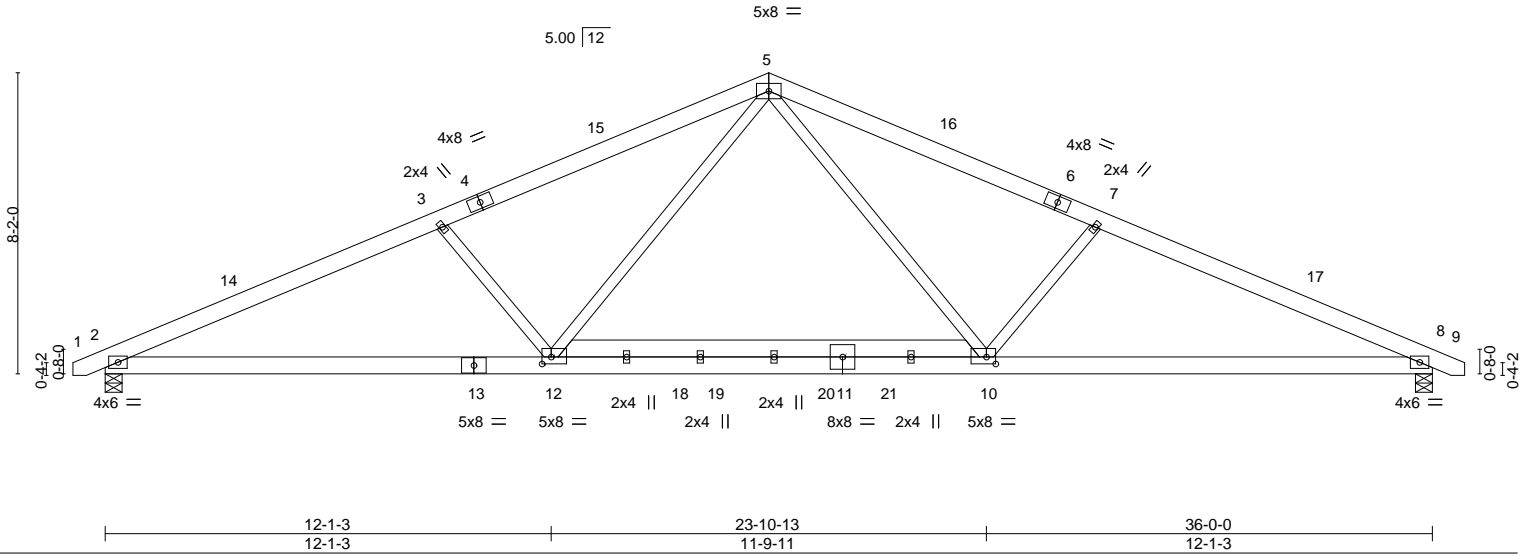

Plate Offsets (X,Y)-- [10:0-3-0,0-2-4], [12:0-3-0,0-2-4]

LOADING (psf)	SPACING-	CSI.	DEFL.	in (loc)	l/defl	L/d	PLATES	GRIP
TCLL 20.0	Plate Grip DOL 1.15	TC 0.43	Vert(LL) -0.23	10-12	>999	360	MT20	244/190
TCDL 10.0	Lumber DOL 1.15	BC 0.86	Vert(CT) -0.57	10-12	>750	240		
BCLL 0.0 *	Rep Stress Incr NO	WB 0.26	Horz(CT) 0.08	8	n/a	n/a		
BCDL 10.0	Code IRC2015/TPI2014	Matrix-S	Wind(LL) 0.08	2-12	>999	240		
							Weight: 248 lb	FT = 20%

LUMBER-
 TOP CHORD 2x6 SP No.1
 BOT CHORD 2x6 SP No.1
 WEBS 2x4 SP No.2 *Except*
 10-12: 2x6 SP No.1

BRACING-
 TOP CHORD Structural wood sheathing directly applied or 3-11-4 oc purlins.
 BOT CHORD Rigid ceiling directly applied or 10-0-0 oc bracing.

REACTIONS. (size) 2=0-5-8, 8=0-5-8
 Max Horz 2=-99(LC 17)
 Max Uplift 2=-9(LC 12), 8=-9(LC 13)
 Max Grav 2=1669(LC 1), 8=1669(LC 1)

FORCES. (lb) - Max. Comp./Max. Ten. - All forces 250 (lb) or less except when shown.
 TOP CHORD 2-3=-3227/366, 3-5=-2886/329, 5-7=-2886/329, 7-8=-3227/366
 BOT CHORD 2-12=-233/2877, 10-12=-33/1935, 8-10=-234/2877
 WEBS 5-10=0/1047, 7-10=-552/336, 5-12=0/1047, 3-12=-552/336

- NOTES-**
- Unbalanced roof live loads have been considered for this design.
 - Wind: ASCE 7-10; Vult=130mph (3-second gust) Vasd=103mph; TCCL=6.0psf; BCDL=6.0psf; h=15ft; Cat. II; Exp C; Enclosed; MWFRS (envelope) and C-C Exterior(2) -0-8-5 to 3-8-8, Interior(1) 3-8-8 to 18-0-0, Exterior(2) 18-0-0 to 22-4-13, Interior(1) 22-4-13 to 36-8-5 zone:C-C for members and forces & MWFRS for reactions shown; Lumber DOL=1.60 plate grip DOL=1.60
 - 200.0lb AC unit load placed on the bottom chord, 18-0-0 from left end, supported at two points, 3-0-0 apart.
 - This truss has been designed for a 10.0 psf bottom chord live load nonconcurrent with any other live loads.
 - * This truss has been designed for a live load of 20.0psf on the bottom chord in all areas where a rectangle 3-6-0 tall by 2-0-0 wide will fit between the bottom chord and any other members, with BCDL = 10.0psf.
 - Provide mechanical connection (by others) of truss to bearing plate capable of withstanding 100 lb uplift at joint(s) 2, 8.

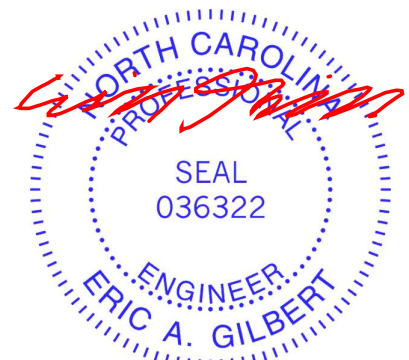

February 1, 2021

Job	Truss	Truss Type	Qty	Ply	Lot 10 Pendegrift Rd.	E15364187
J0621-4013	A3	COMMON	8	1		

Comtech, Inc., Fayetteville, NC - 28314,

8.330 s Oct 7 2020 MiTek Industries, Inc. Sun Jan 31 13:50:30 2021 Page 1

ID:0iJ2hz3vp6ahZXsX7jdYHSym1hi-FmOu2TtN5HUYG5fFRhqw1uWQ_WRZ??_CUJYyb?zppjt

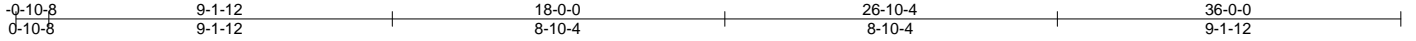

Scale = 1:61.3

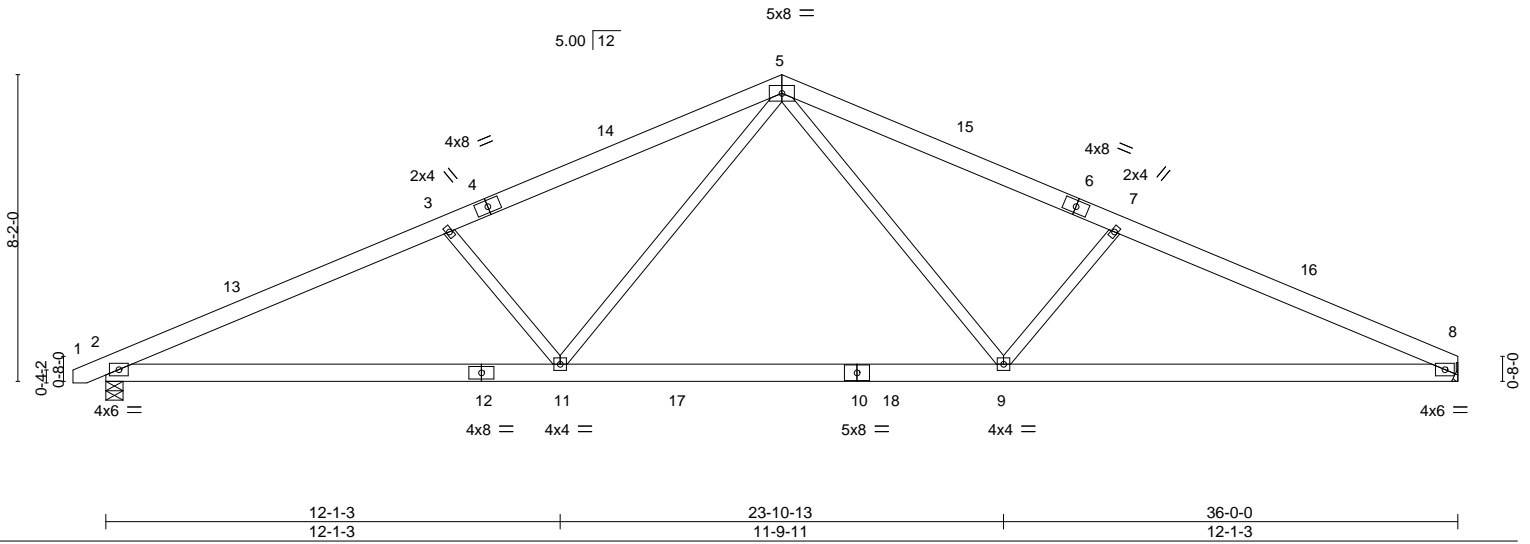

LOADING (psf)	SPACING-	CSI.	DEFL.	PLATES	GRIP
TCLL 20.0	2-0-0	TC 0.39	in (loc) l/defl L/d	MT20	244/190
TCDL 10.0	Plate Grip DOL 1.15	BC 0.62	Vert(LL) -0.33 9-11 >999 360		
BCLL 0.0 *	Lumber DOL 1.15	WB 0.23	Vert(CT) -0.46 9-11 >929 240		
BCDL 10.0	Rep Stress Incr YES	Matrix-S	Horz(CT) 0.07 8 n/a n/a		
	Code IRC2015/TPI2014		Wind(LL) 0.07 11 >999 240	Weight: 220 lb	FT = 20%

LUMBER-	BRACING-
TOP CHORD 2x6 SP No.1	TOP CHORD Structural wood sheathing directly applied or 4-1-11 oc purlins.
BOT CHORD 2x6 SP No.1	BOT CHORD Rigid ceiling directly applied or 10-0-0 oc bracing.
WEBS 2x4 SP No.2	

REACTIONS. (size) 2=0-5-8, 8=Mechanical
 Max Horz 2=95(LC 16)
 Max Uplift 2=102(LC 12), 8=90(LC 13)
 Max Grav 2=1483(LC 1), 8=1427(LC 1)

FORCES. (lb) - Max. Comp./Max. Ten. - All forces 250 (lb) or less except when shown.
 TOP CHORD 2-3=-2795/606, 3-5=-2523/575, 5-7=-2541/593, 7-8=-2823/631
 BOT CHORD 2-11=-464/2490, 9-11=-207/1686, 8-9=-470/2523
 WEBS 5-9=-120/956, 7-9=-556/311, 5-11=-115/931, 3-11=-534/302

- NOTES-**
- Unbalanced roof live loads have been considered for this design.
 - Wind: ASCE 7-10; Vult=130mph (3-second gust) Vasd=103mph; TCDL=6.0psf; BCDL=6.0psf; h=15ft; Cat. II; Exp C; Enclosed; MWFRS (envelope) and C-C Exterior(2) -0-8-5 to 3-8-8, Interior(1) 3-8-8 to 18-0-0, Exterior(2) 18-0-0 to 22-4-13, Interior(1) 22-4-13 to 35-11-0 zone; C-C for members and forces & MWFRS for reactions shown; Lumber DOL=1.60 plate grip DOL=1.60
 - This truss has been designed for a 10.0 psf bottom chord live load nonconcurrent with any other live loads.
 - * This truss has been designed for a live load of 30.0psf on the bottom chord in all areas where a rectangle 3-6-0 tall by 2-0-0 wide will fit between the bottom chord and any other members, with BCDL = 10.0psf.
 - Refer to girder(s) for truss to truss connections.
 - Provide mechanical connection (by others) of truss to bearing plate capable of withstanding 100 lb uplift at joint(s) 8 except (jt=lb) 2=102.



February 1, 2021

Job	Truss	Truss Type	Qty	Ply	Lot 10 Pendegrift Rd.	E15364188
J0621-4013	A4	GABLE	1	1		

Comtech, Inc, Fayetteville, NC - 28314,

8.330 s Oct 7 2020 MiTek Industries, Inc. Sun Jan 31 13:50:32 2021 Page 1

ID:0iJ2hz3vp6ahZXSx7jdYHSym1hi-C9WeT9vedukGWOpEY6tO6JbrlJGNTv4Vyd02guzppjr

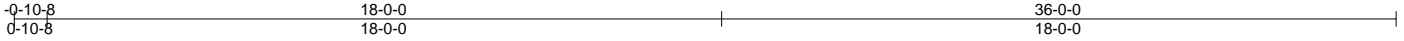

Scale = 1:61.5

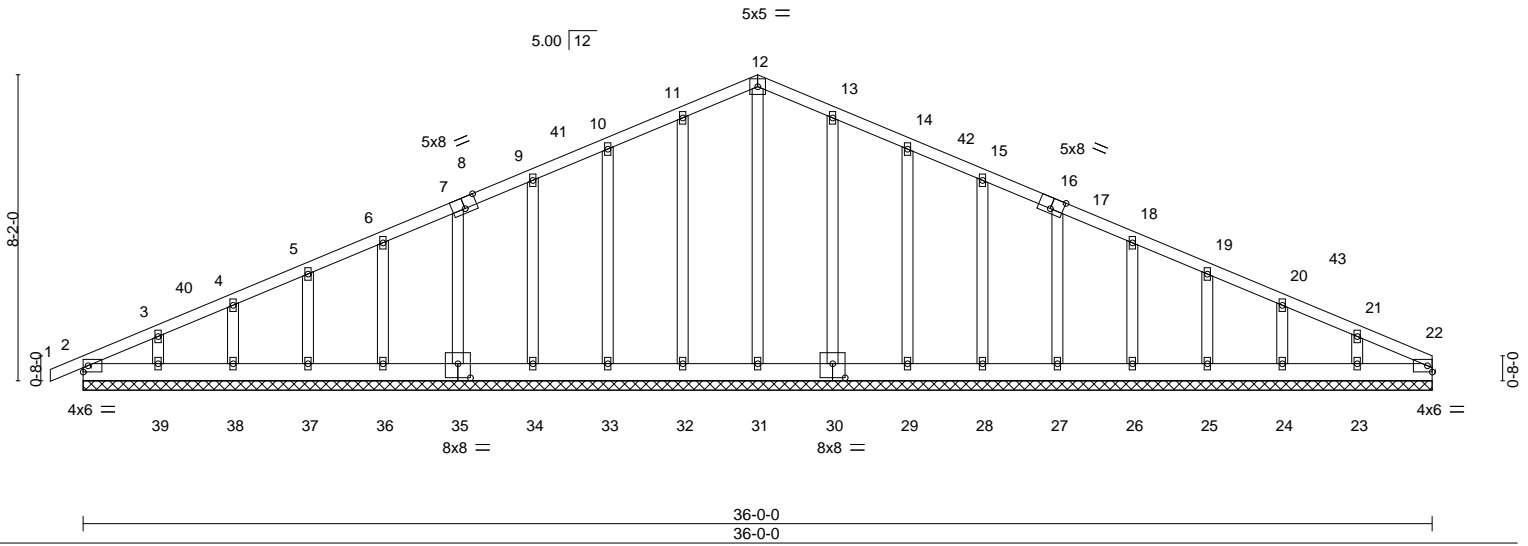

Plate Offsets (X,Y)-- [7:0-1-14,0-0-0], [8:0-4-0,Edge], [8:0-0-0,0-1-12], [16:0-4-0,Edge], [16:0-0-0,0-1-12], [17:0-1-14,0-0-0], [30:0-4-0,0-4-8], [35:0-4-0,0-4-8]

LOADING (psf)	SPACING-	CSL	DEFL.	in (loc)	l/defl	L/d	PLATES	GRIP
TCLL 20.0	Plate Grip DOL 1.15	TC 0.06	Vert(LL) -0.00	1	n/r	120	MT20	244/190
TCDL 10.0	Lumber DOL 1.15	BC 0.02	Vert(CT) -0.00	1	n/r	120		
BCLL 0.0 *	Rep Stress Incr YES	WB 0.13	Horz(CT) 0.01	22	n/a	n/a		
BCDL 10.0	Code IRC2015/TPI2014	Matrix-S					Weight: 243 lb	FT = 20%

LUMBER-
TOP CHORD 2x4 SP No.1
BOT CHORD 2x6 SP No.1
OTHERS 2x4 SP No.2

BRACING-
TOP CHORD Structural wood sheathing directly applied or 6-0-0 oc purlins.
BOT CHORD Rigid ceiling directly applied or 10-0-0 oc bracing.

REACTIONS. All bearings 36-0-0.
(lb) - Max Horz 2=161(LC 12)
Max Uplift All uplift 100 lb or less at joint(s) 2, 32, 33, 34, 35, 36, 37, 38, 39, 30, 29, 28, 27, 26, 25, 24, 23
Max Grav All reactions 250 lb or less at joint(s) 2, 22, 31, 32, 33, 34, 35, 36, 37, 38, 39, 30, 29, 28, 27, 26, 25, 24, 23

FORCES. (lb) - Max. Comp./Max. Ten. - All forces 250 (lb) or less except when shown.
TOP CHORD 10-11=-84/251, 11-12=-101/295, 12-13=-101/298, 13-14=-84/255

- NOTES-**
- Unbalanced roof live loads have been considered for this design.
 - Wind: ASCE 7-10; Vult=130mph (3-second gust) Vasd=103mph; TC DL=6.0psf; BCDL=6.0psf; h=15ft; Cat. II; Exp C; Enclosed; MWFRS (envelope) gable end zone and C-C Corner(3) 0-10-8 to 3-6-5, Exterior(2) 3-6-5 to 18-0-0, Corner(3) 18-0-0 to 22-4-13, Exterior(2) 22-4-13 to 36-0-0 zone; C-C for members and forces & MWFRS for reactions shown; Lumber DOL=1.60 plate grip DOL=1.60
 - Truss designed for wind loads in the plane of the truss only. For studs exposed to wind (normal to the face), see Standard Industry Gable End Details as applicable, or consult qualified building designer as per ANSI/TPI 1.
 - All plates are 2x4 MT20 unless otherwise indicated.
 - Gable requires continuous bottom chord bearing.
 - Gable studs spaced at 2-0-0 oc.
 - This truss has been designed for a 10.0 psf bottom chord live load nonconcurrent with any other live loads.
 - * This truss has been designed for a live load of 20.0psf on the bottom chord in all areas with a clearance greater than 6-0-0 between the bottom chord and any other members, with BCDL = 10.0psf.
 - Provide mechanical connection (by others) of truss to bearing plate capable of withstanding 100 lb uplift at joint(s) 2, 32, 33, 34, 35, 36, 37, 38, 39, 30, 29, 28, 27, 26, 25, 24, 23.



February 1, 2021

WARNING - Verify design parameters and READ NOTES ON THIS AND INCLUDED MITEK REFERENCE PAGE MII-7473 rev. 5/19/2020 BEFORE USE.

Design valid for use only with MiTek® connectors. This design is based only upon parameters shown, and is for an individual building component, not a truss system. Before use, the building designer must verify the applicability of design parameters and properly incorporate this design into the overall building design. Bracing indicated is to prevent buckling of individual truss web and/or chord members only. Additional temporary and permanent bracing is always required for stability and to prevent collapse with possible personal injury and property damage. For general guidance regarding the fabrication, storage, delivery, erection and bracing of trusses and truss systems, see

ANSI/TPI1 Quality Criteria, DSB-89 and BCSI Building Component

Safety Information available from Truss Plate Institute, 2670 Crain Highway, Suite 203 Waldorf, MD 20601



818 Soundside Road
Edenton, NC 27932

Job	Truss	Truss Type	Qty	Ply	Lot 10 Pendegrift Rd.	E15364189
J0621-4013	B1	GABLE	1	1		

Comtech, Inc, Fayetteville, NC - 28314,

8.330 s Oct 7 2020 MiTek Industries, Inc. Sun Jan 31 13:50:33 2021 Page 1

ID:0iJ2hz3vp6ahZXSx7jdYHSym1hi-gL40gVwGOCs77YOq6pOdeX80mjcdCNFeAHlcCKzppjq

0-10-8 8-9-12 17-7-8 18-6-0
 0-10-8 8-9-12 8-9-12 0-10-8

4x6 =

Scale: 1/4"=1'

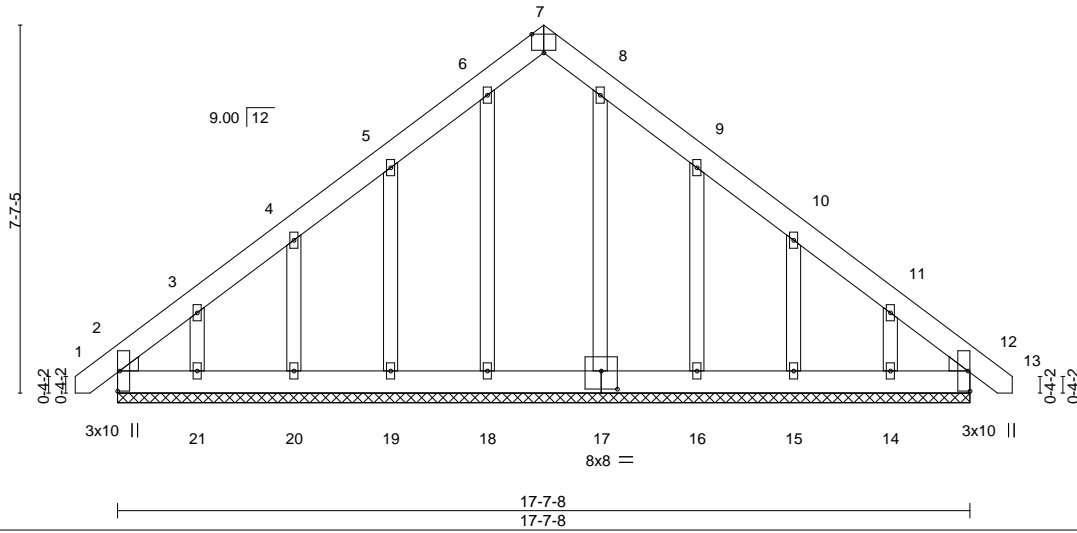

Plate Offsets (X,Y)-- [2:0-0-6,0-3-10], [2:0-0-3,0-0-4], [7:0-3-0,Edge], [12:0-0-6,0-3-10], [12:0-0-3,0-0-4], [17:0-4-0,0-4-8]

LOADING (psf)	SPACING-	CSI.	DEFL.	in (loc)	l/defl	L/d	PLATES	GRIP
TCLL 20.0	Plate Grip DOL 1.15	TC 0.04	Vert(LL) -0.00	12	n/r	120	MT20	244/190
TCDL 10.0	Lumber DOL 1.15	BC 0.02	Vert(CT) -0.00	12	n/r	120		
BCLL 0.0 *	Rep Stress Incr YES	WB 0.07	Horz(CT) 0.00	12	n/a	n/a		
BCDL 10.0	Code IRC2015/TPI2014	Matrix-S						
							Weight: 142 lb	FT = 20%

LUMBER-
 TOP CHORD 2x6 SP No.1
 BOT CHORD 2x6 SP No.1
 OTHERS 2x4 SP No.2
 WEDGE
 Left: 2x4 SP No.3 , Right: 2x4 SP No.3

BRACING-
 TOP CHORD Structural wood sheathing directly applied or 6-0-0 oc purlins.
 BOT CHORD Rigid ceiling directly applied or 10-0-0 oc bracing.

REACTIONS. All bearings 17-7-8.
 (lb) - Max Horz 2=171(LC 10)
 Max Uplift All uplift 100 lb or less at joint(s) 2, 19, 20, 21, 16, 15, 14, 12
 Max Grav All reactions 250 lb or less at joint(s) 2, 18, 19, 20, 21, 17, 16, 15, 14, 12

FORCES. (lb) - Max. Comp./Max. Ten. - All forces 250 (lb) or less except when shown.

- NOTES-**
- Unbalanced roof live loads have been considered for this design.
 - Wind: ASCE 7-10; Vult=130mph (3-second gust) Vasd=103mph; TC DL=6.0psf; BCDL=6.0psf; h=15ft; Cat. II; Exp C; Enclosed; MWFRS (envelope) and C-C Corner(3) -0-8-11 to 3-7-12, Exterior(2) 3-7-12 to 8-9-12, Corner(3) 8-9-12 to 13-2-9, Exterior(2) 13-2-9 to 18-4-3 zone; C-C for members and forces & MWFRS for reactions shown; Lumber DOL=1.60 plate grip DOL=1.60
 - Truss designed for wind loads in the plane of the truss only. For studs exposed to wind (normal to the face), see Standard Industry Gable End Details as applicable, or consult qualified building designer as per ANSI/TPI 1.
 - All plates are 2x4 MT20 unless otherwise indicated.
 - Gable requires continuous bottom chord bearing.
 - Gable studs spaced at 2-0-0 oc.
 - This truss has been designed for a 10.0 psf bottom chord live load nonconcurrent with any other live loads.
 - * This truss has been designed for a live load of 20.0psf on the bottom chord in all areas with a clearance greater than 6-0-0 between the bottom chord and any other members, with BCDL = 10.0psf.
 - Provide mechanical connection (by others) of truss to bearing plate capable of withstanding 100 lb uplift at joint(s) 2, 19, 20, 21, 16, 15, 14, 12.



February 1, 2021

WARNING - Verify design parameters and READ NOTES ON THIS AND INCLUDED MITEK REFERENCE PAGE MII-7473 rev. 5/19/2020 BEFORE USE.

Design valid for use only with MiTek® connectors. This design is based only upon parameters shown, and is for an individual building component, not a truss system. Before use, the building designer must verify the applicability of design parameters and properly incorporate this design into the overall building design. Bracing indicated is to prevent buckling of individual truss web and/or chord members only. Additional temporary and permanent bracing is always required for stability and to prevent collapse with possible personal injury and property damage. For general guidance regarding the fabrication, storage, delivery, erection and bracing of trusses and truss systems, see

ANSI/TPI1 Quality Criteria, DSB-89 and BCSI Building Component

Safety Information available from Truss Plate Institute, 2670 Crain Highway, Suite 203 Waldorf, MD 20601



818 Soundside Road
 Edenton, NC 27932

Job	Truss	Truss Type	Qty	Ply	Lot 10 Pendegrift Rd.	E15364190
J0621-4013	B2	Common Girder	1	2	Job Reference (optional)	

Comtech, Inc, Fayetteville, NC - 28314,

8.330 s Oct 7 2020 MiTek Industries, Inc. Sun Jan 31 13:50:34 2021 Page 1
 ID:0iJ2hz3vp6ahZXSx7jdYHSym1hi-8XeOurwu9V__liz0gXvsBkhy?7pkxjFoPxv9kmzppj

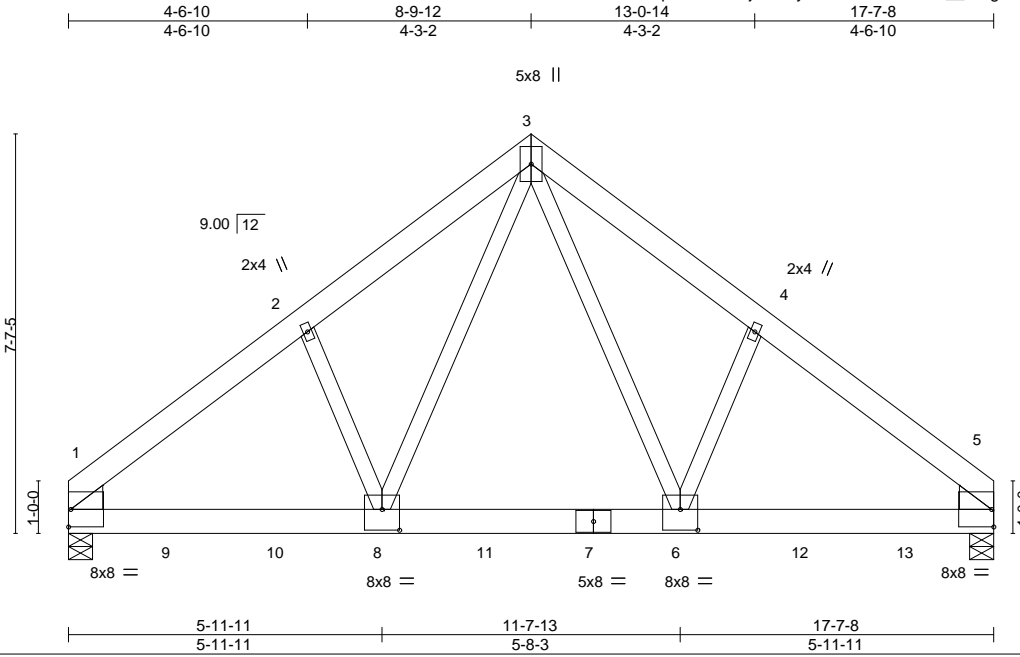

Scale = 1:43.9

Plate Offsets (X,Y)-- [1:0-0-4,0-0-3], [1:0-5-6,0-0-6], [5:0-5-6,0-0-6], [5:0-0-4,0-0-3], [6:0-4-0,0-4-12], [8:0-4-0,0-4-12]

LOADING (psf)	SPACING-	CSI.	DEFL.	in (loc)	l/defl	L/d	PLATES	GRIP
TCLL 20.0	Plate Grip DOL 1.15	TC 0.97	Vert(LL) -0.07	1-8	>999	360	MT20	244/190
TCDL 10.0	Lumber DOL 1.15	BC 0.60	Vert(CT) -0.15	1-8	>999	240		
BCLL 0.0 *	Rep Stress Incr NO	WB 0.54	Horz(CT) 0.03	5	n/a	n/a		
BCDL 10.0	Code IRC2015/TPI2014	Matrix-S	Wind(LL) 0.05	1-8	>999	240		
							Weight: 259 lb	FT = 20%

LUMBER-
 TOP CHORD 2x6 SP No.1
 BOT CHORD 2x6 SP 2400F 2.0E
 WEBS 2x4 SP No.2
 WEDGE
 Left: 2x6 SP No.1 , Right: 2x6 SP No.1

BRACING-
 TOP CHORD Structural wood sheathing directly applied or 5-10-11 oc purlins.
 BOT CHORD Rigid ceiling directly applied or 10-0-0 oc bracing.

REACTIONS. (size) 1=0-5-8, 5=0-5-8
 Max Horz 1=170(LC 24)
 Max Uplift 1=-435(LC 8), 5=-444(LC 9)
 Max Grav 1=6247(LC 1), 5=6381(LC 1)

FORCES. (lb) - Max. Comp./Max. Ten. - All forces 250 (lb) or less except when shown.
 TOP CHORD 1-2=-7349/535, 2-3=-7051/598, 3-4=-7059/598, 4-5=-7357/535
 BOT CHORD 1-8=-411/5448, 6-8=-240/3992, 5-6=-350/5454
 WEBS 3-6=-382/4380, 4-6=-191/571, 3-8=-380/4363, 2-8=-191/571

- NOTES-**
- 2-ply truss to be connected together with 10d (0.131"x3") nails as follows:
 Top chords connected as follows: 2x6 - 2 rows staggered at 0-9-0 oc.
 Bottom chords connected as follows: 2x6 - 2 rows staggered at 0-6-0 oc.
 Webs connected as follows: 2x4 - 1 row at 0-9-0 oc.
 - All loads are considered equally applied to all plies, except if noted as front (F) or back (B) face in the LOAD CASE(S) section. Ply to ply connections have been provided to distribute only loads noted as (F) or (B), unless otherwise indicated.
 - Unbalanced roof live loads have been considered for this design.
 - Wind: ASCE 7-10; Vult=130mph (3-second gust) Vasd=103mph; TC DL=6.0psf; BCDL=6.0psf; h=15ft; Cat. II; Exp C; Enclosed; MWFRS (envelope); Lumber DOL=1.60 plate grip DOL=1.60
 - This truss has been designed for a 10.0 psf bottom chord live load nonconcurrent with any other live loads.
 - * This truss has been designed for a live load of 20.0psf on the bottom chord in all areas where a rectangle 3-6-0 tall by 2-0-0 wide will fit between the bottom chord and any other members, with BCDL = 10.0psf.
 - Provide mechanical connection (by others) of truss to bearing plate capable of withstanding 100 lb uplift at joint(s) except (jt=lb) 1=435, 5=444.
 - Hanger(s) or other connection device(s) shall be provided sufficient to support concentrated load(s) 1407 lb down and 110 lb up at 1-11-4, 1407 lb down and 110 lb up at 3-11-4, 1407 lb down and 110 lb up at 5-11-4, 1407 lb down and 110 lb up at 7-11-4, 1407 lb down and 110 lb up at 9-11-4, 1407 lb down and 110 lb up at 11-11-4, and 1407 lb down and 110 lb up at 13-11-4, and 1407 lb down and 110 lb up at 15-11-4 on bottom chord. The design/selection of such connection device(s) is the responsibility of others.

LOAD CASE(S) Standard
 1) Dead + Roof Live (balanced): Lumber Increase=1.15, Plate Increase=1.15



February 1, 2021

Continued on page 2

WARNING - Verify design parameters and READ NOTES ON THIS AND INCLUDED MITEK REFERENCE PAGE MII-7473 rev. 5/19/2020 BEFORE USE.
 Design valid for use only with MiTek® connectors. This design is based only upon parameters shown, and is for an individual building component, not a truss system. Before use, the building designer must verify the applicability of design parameters and properly incorporate this design into the overall building design. Bracing indicated is to prevent buckling of individual truss web and/or chord members only. Additional temporary and permanent bracing is always required for stability and to prevent collapse with possible personal injury and property damage. For general guidance regarding the fabrication, storage, delivery, erection and bracing of trusses and truss systems, see **ANSI/TPI1 Quality Criteria, DSB-89 and BCSI Building Component Safety Information** available from Truss Plate Institute, 2670 Crain Highway, Suite 203 Waldorf, MD 20601



818 Soundside Road
 Edenton, NC 27932

Job	Truss	Truss Type	Qty	Ply	Lot 10 Pendegrift Rd.	E15364190
J0621-4013	B2	Common Girder	1	2	Job Reference (optional)	

Comtech, Inc, Fayetteville, NC - 28314,

8.330 s Oct 7 2020 MiTek Industries, Inc. Sun Jan 31 13:50:34 2021 Page 2
 ID:0iJ2hz3vp6ahZXSx7jdYHSym1hi-8XeOurwu9V__liz0gXvsBkhy?7pkxjFoPxV9kmzppjp

LOAD CASE(S) Standard

Uniform Loads (plf)

Vert: 1-3=-60, 3-5=-60, 1-5=-20

Concentrated Loads (lb)

Vert: 7=-1407(B) 6=-1407(B) 8=-1407(B) 9=-1407(B) 10=-1407(B) 11=-1407(B) 12=-1407(B) 13=-1407(B)

WARNING - Verify design parameters and READ NOTES ON THIS AND INCLUDED MITEK REFERENCE PAGE MII-7473 rev. 5/19/2020 BEFORE USE.

Design valid for use only with MiTek® connectors. This design is based only upon parameters shown, and is for an individual building component, not a truss system. Before use, the building designer must verify the applicability of design parameters and properly incorporate this design into the overall building design. Bracing indicated is to prevent buckling of individual truss web and/or chord members only. Additional temporary and permanent bracing is always required for stability and to prevent collapse with possible personal injury and property damage. For general guidance regarding the fabrication, storage, delivery, erection and bracing of trusses and truss systems, see **ANSI/TPI1 Quality Criteria, DSB-89 and BCSI Building Component Safety Information** available from Truss Plate Institute, 2670 Crain Highway, Suite 203 Waldorf, MD 20601



818 Soundside Road
 Edenton, NC 27932

Job	Truss	Truss Type	Qty	Ply	Lot 10 Pendegrift Rd.	E15364191
J0621-4013	G01	GABLE	1	1		

Comtech, Inc., Fayetteville, NC - 28314,

8.330 s Oct 7 2020 MiTek Industries, Inc. Sun Jan 31 13:50:35 2021 Page 1

ID:0iJ2hz3vp6ahZXSx7jdYHSym1hi-ckCm5BxWwp6qNsYDDEQ5kyDM9XIAGLxebEjHCzppjo

Job Reference (optional)

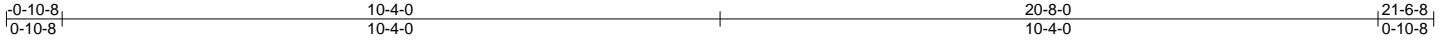

Scale = 1:36.2

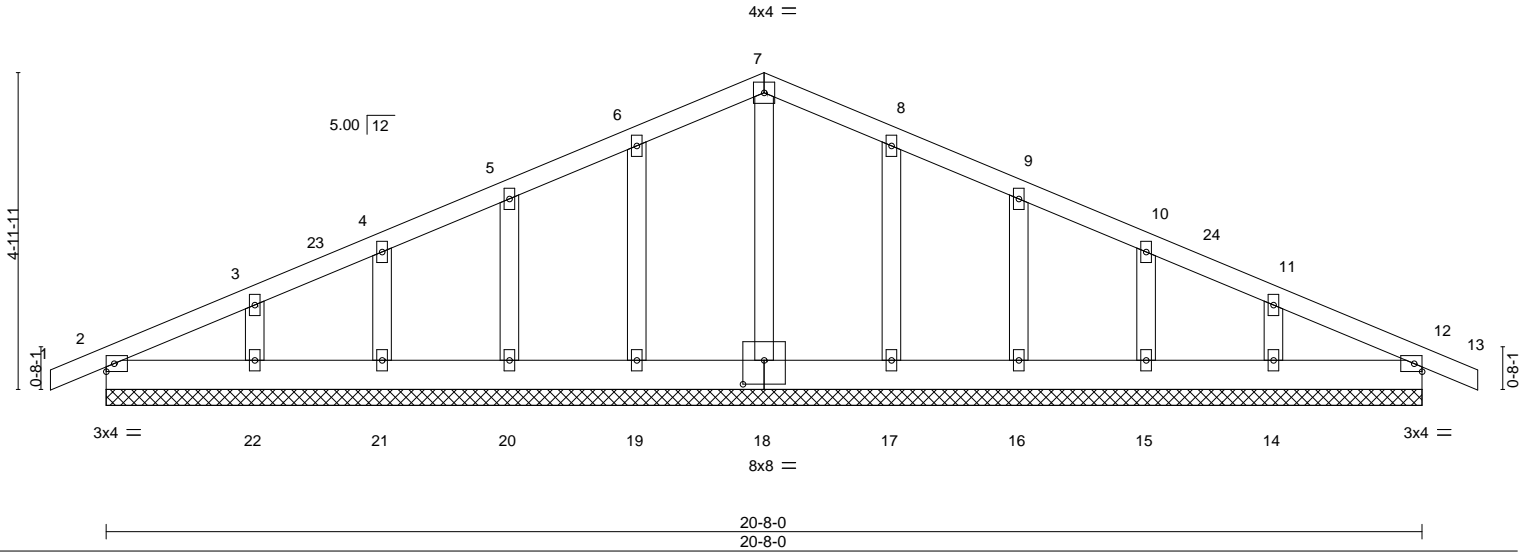

Plate Offsets (X,Y)-- [18:0-4-0,0-4-8]

LOADING (psf)	SPACING-	CSI.	DEFL.	in (loc)	l/defl	L/d	PLATES	GRIP
TCLL 20.0	Plate Grip DOL 1.15	TC 0.05	Vert(LL) -0.00	12	n/r	120	MT20	244/190
TCDL 10.0	Lumber DOL 1.15	BC 0.02	Vert(CT) -0.00	12	n/r	120		
BCLL 0.0 *	Rep Stress Incr NO	WB 0.04	Horz(CT) 0.00	12	n/a	n/a		
BCDL 10.0	Code IRC2015/TPI2014	Matrix-S						
							Weight: 117 lb	FT = 20%

LUMBER-
 TOP CHORD 2x4 SP No.1
 BOT CHORD 2x6 SP No.1
 OTHERS 2x4 SP No.2

BRACING-
 TOP CHORD Structural wood sheathing directly applied or 6-0-0 oc purlins.
 BOT CHORD Rigid ceiling directly applied or 10-0-0 oc bracing.

REACTIONS. All bearings 20-8-0.
 (lb) - Max Horz 2=94(LC 16)
 Max Uplift All uplift 100 lb or less at joint(s) 12, 2, 19, 20, 21, 22, 17, 16, 15, 14
 Max Grav All reactions 250 lb or less at joint(s) 12, 2, 18, 19, 20, 21, 22, 17, 16, 15, 14

FORCES. (lb) - Max. Comp./Max. Ten. - All forces 250 (lb) or less except when shown.

- NOTES-**
- Unbalanced roof live loads have been considered for this design.
 - Wind: ASCE 7-10; Vult=130mph (3-second gust) Vasd=103mph; TCDL=6.0psf; BCDL=6.0psf; h=15ft; Cat. II; Exp C; Enclosed; MWFRS (envelope) gable end zone and C-C Exterior(2) -0-10-8 to 3-6-5, Interior(1) 3-6-5 to 10-4-0, Exterior(2) 10-4-0 to 16-4-0, Interior(1) 16-4-0 to 21-6-8 zone; C-C for members and forces & MWFRS for reactions shown; Lumber DOL=1.60 plate grip DOL=1.60
 - Truss designed for wind loads in the plane of the truss only. For studs exposed to wind (normal to the face), see Standard Industry Gable End Details as applicable, or consult qualified building designer as per ANSI/TPI 1.
 - All plates are 2x4 MT20 unless otherwise indicated.
 - Gable requires continuous bottom chord bearing.
 - Gable studs spaced at 2-0-0 oc.
 - This truss has been designed for a 10.0 psf bottom chord live load nonconcurrent with any other live loads.
 - * This truss has been designed for a live load of 20.0psf on the bottom chord in all areas with a clearance greater than 6-0-0 between the bottom chord and any other members.
 - Provide mechanical connection (by others) of truss to bearing plate capable of withstanding 100 lb uplift at joint(s) 12, 2, 19, 20, 21, 22, 17, 16, 15, 14.

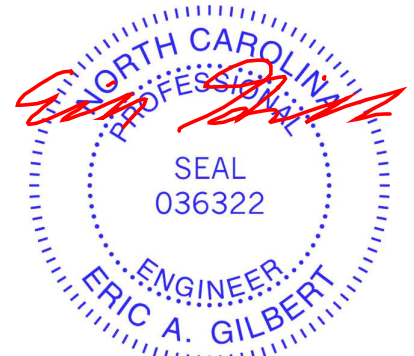

February 1, 2021

WARNING - Verify design parameters and READ NOTES ON THIS AND INCLUDED MITEK REFERENCE PAGE MII-7473 rev. 5/19/2020 BEFORE USE.

Design valid for use only with MiTek® connectors. This design is based only upon parameters shown, and is for an individual building component, not a truss system. Before use, the building designer must verify the applicability of design parameters and properly incorporate this design into the overall building design. Bracing indicated is to prevent buckling of individual truss web and/or chord members only. Additional temporary and permanent bracing is always required for stability and to prevent collapse with possible personal injury and property damage. For general guidance regarding the fabrication, storage, delivery, erection and bracing of trusses and truss systems, see

ANSI/TPI1 Quality Criteria, DSB-89 and BCSI Building Component

Safety Information available from Truss Plate Institute, 2670 Crain Highway, Suite 203 Waldorf, MD 20601



818 Soundside Road
 Edenton, NC 27932

Job	Truss	Truss Type	Qty	Ply	Lot 10 Pendegrft Rd.	E15364192
J0621-4013	G02	COMMON	5	1		

Comtech, Inc. Fayetteville, NC - 28314,

8.330 s Oct 7 2020 MiTek Industries, Inc. Sun Jan 31 13:50:36 2021 Page 1

ID:0iJ2hz3vp6ahZXSx7jdYHSym1hi-4wm9lXy8h7Eh_07PnyxKG9mOwxSHPKU4f_Gpfzppjn

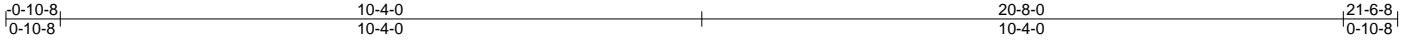

Scale = 1:37.1

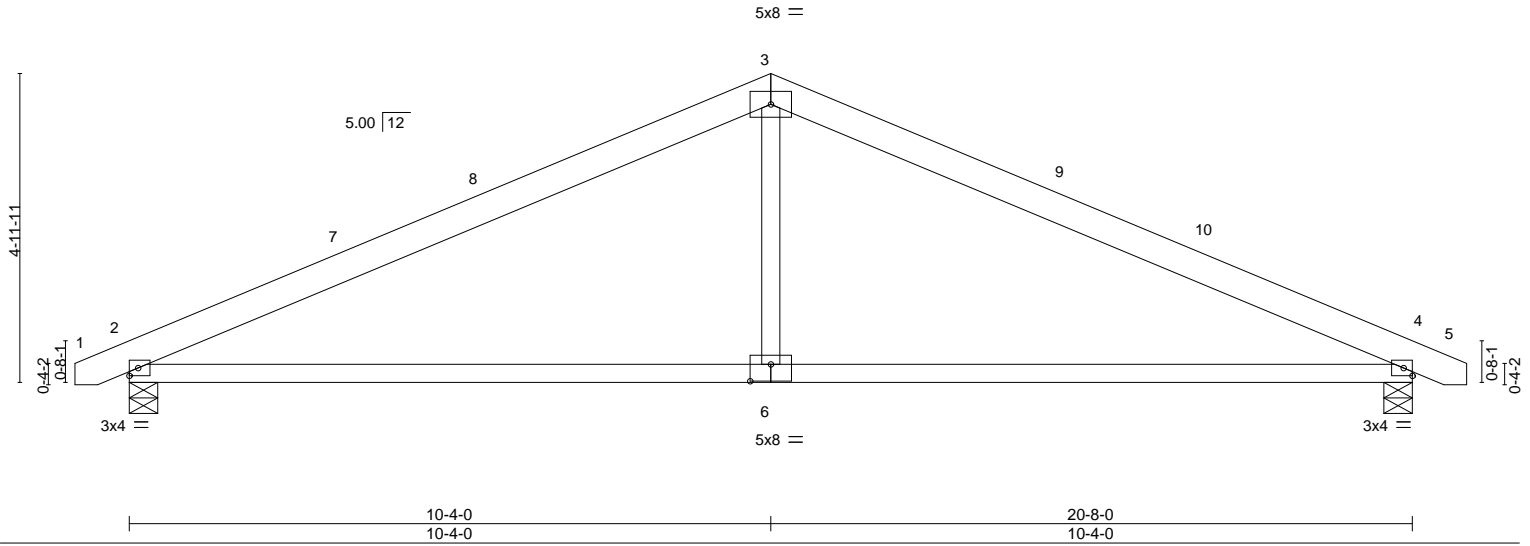

Plate Offsets (X,Y)-- [6:0-4-0,0-3-4]

LOADING (psf)	SPACING-	CSI.	DEFL.	in (loc)	l/defl	L/d	PLATES	GRIP
TCLL 20.0	Plate Grip DOL 1.15	TC 0.62	Vert(LL) -0.19	2-6	>999	360	MT20	244/190
TCDL 10.0	Lumber DOL 1.15	BC 0.79	Vert(CT) -0.40	2-6	>606	240		
BCLL 0.0 *	Rep Stress Incr YES	WB 0.11	Horz(CT) 0.03	4	n/a	n/a		
BCDL 10.0	Code IRC2015/TPI2014	Matrix-S	Wind(LL) 0.06	2-6	>999	240	Weight: 94 lb	FT = 20%

LUMBER-

TOP CHORD 2x6 SP No.1
 BOT CHORD 2x4 SP No.1
 WEBS 2x4 SP No.2

BRACING-

TOP CHORD Structural wood sheathing directly applied or 5-4-12 oc purlins.
 BOT CHORD Rigid ceiling directly applied or 10-0-0 oc bracing.

REACTIONS.

(size) 4=0-5-8, 2=0-5-8
 Max Horz 2=-55(LC 13)
 Max Uplift 4=-63(LC 13), 2=-63(LC 12)
 Max Grav 4=864(LC 1), 2=864(LC 1)

FORCES. (lb) - Max. Comp./Max. Ten. - All forces 250 (lb) or less except when shown.

TOP CHORD 2-3=-1216/288, 3-4=-1216/288
 BOT CHORD 2-6=-140/1030, 4-6=-140/1030
 WEBS 3-6=0/468

NOTES-

- Unbalanced roof live loads have been considered for this design.
- Wind: ASCE 7-10; Vult=130mph (3-second gust) Vasd=103mph; TC DL=6.0psf; BCDL=6.0psf; h=15ft; Cat. II; Exp C; Enclosed; MWFRS (envelope) and C-C Exterior(2) -0-8-5 to 3-8-8, Interior(1) 3-8-8 to 10-4-0, Exterior(2) 10-4-0 to 14-8-13, Interior(1) 14-8-13 to 21-4-5 zone; C-C for members and forces & MWFRS for reactions shown; Lumber DOL=1.60 plate grip DOL=1.60
- This truss has been designed for a 10.0 psf bottom chord live load nonconcurrent with any other live loads.
- * This truss has been designed for a live load of 20.0psf on the bottom chord in all areas with a clearance greater than 6-0-0 between the bottom chord and any other members.
- Provide mechanical connection (by others) of truss to bearing plate capable of withstanding 100 lb uplift at joint(s) 4, 2.

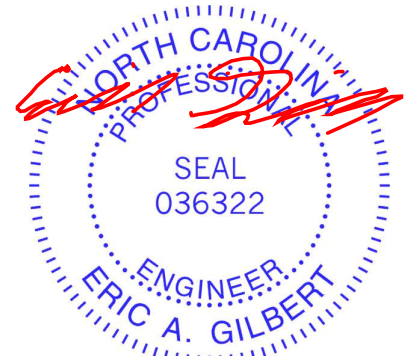

February 1, 2021

WARNING - Verify design parameters and READ NOTES ON THIS AND INCLUDED MITEK REFERENCE PAGE MII-7473 rev. 5/19/2020 BEFORE USE.

Design valid for use only with MiTek® connectors. This design is based only upon parameters shown, and is for an individual building component, not a truss system. Before use, the building designer must verify the applicability of design parameters and properly incorporate this design into the overall building design. Bracing indicated is to prevent buckling of individual truss web and/or chord members only. Additional temporary and permanent bracing is always required for stability and to prevent collapse with possible personal injury and property damage. For general guidance regarding the fabrication, storage, delivery, erection and bracing of trusses and truss systems, see

ANSI/TPI1 Quality Criteria, DSB-89 and BCSI Building Component

Safety Information available from Truss Plate Institute, 2670 Crain Highway, Suite 203 Waldorf, MD 20601



818 Soundside Road
 Edenton, NC 27932

Job	Truss	Truss Type	Qty	Ply	Lot 10 Pendegraft Rd.	E15364193
J0621-4013	M01	MONOPITCH SUPPORTED	2	1	Job Reference (optional)	

Comtech, Inc, Fayetteville, NC - 28314,

8.330 s Oct 7 2020 MiTek Industries, Inc. Sun Jan 31 13:50:37 2021 Page 1
 ID:0iJ2hz3vp6ahZXSx7jdYHSym1hi-Y6JXWtzmSQMYcAibLfsZpNJh0Kz58CXE5vjpL5zppjm



Scale = 1:11.5

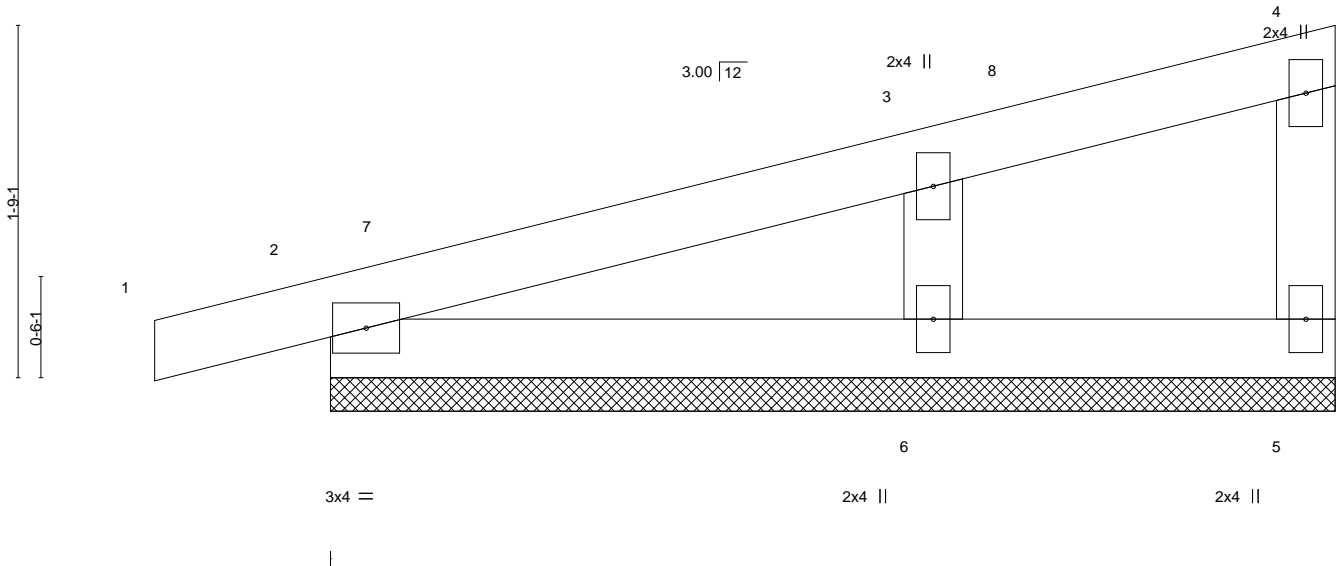

LOADING (psf)	SPACING-	2-0-0	CSI.	DEFL.	in	(loc)	l/defl	L/d	PLATES	GRIP
TCLL 20.0	Plate Grip DOL	1.15	TC 0.09	Vert(LL)	-0.00	1	n/r	120	MT20	244/190
TCDL 10.0	Lumber DOL	1.15	BC 0.05	Vert(CT)	0.00	1	n/r	120		
BCLL 0.0 *	Rep Stress Incr	YES	WB 0.05	Horz(CT)	0.00		n/a	n/a		
BCDL 10.0	Code IRC2015/TPI2014		Matrix-P						Weight: 19 lb	FT = 20%

LUMBER-
 TOP CHORD 2x4 SP No.1
 BOT CHORD 2x4 SP No.1
 WEBS 2x4 SP No.2
 OTHERS 2x4 SP No.2

BRACING-
 TOP CHORD Structural wood sheathing directly applied or 5-0-0 oc purlins.
 BOT CHORD Rigid ceiling directly applied or 10-0-0 oc bracing.

REACTIONS. (size) 5=5-0-0, 2=5-0-0, 6=5-0-0
 Max Horz 2=47(LC 8)
 Max Uplift 5=-7(LC 8), 2=-37(LC 8), 6=-34(LC 12)
 Max Grav 5=41(LC 1), 2=160(LC 1), 6=240(LC 1)

FORCES. (lb) - Max. Comp./Max. Ten. - All forces 250 (lb) or less except when shown.
 WEBS 3-6=-176/310

- NOTES-**
- 1) Wind: ASCE 7-10; Vult=130mph (3-second gust) Vasd=103mph; TCDL=6.0psf; BCDL=6.0psf; h=15ft; Cat. II; Exp C; Enclosed; MWFRS (envelope) and C-C Corner(3) -0-10-8 to 3-6-5, Exterior(2) 3-6-5 to 4-10-4 zone;C-C for members and forces & MWFRS for reactions shown; Lumber DOL=1.60 plate grip DOL=1.60
 - 2) Truss designed for wind loads in the plane of the truss only. For studs exposed to wind (normal to the face), see Standard Industry Gable End Details as applicable, or consult qualified building designer as per ANSI/TPI 1.
 - 3) Gable requires continuous bottom chord bearing.
 - 4) Gable studs spaced at 2-0-0 oc.
 - 5) This truss has been designed for a 10.0 psf bottom chord live load nonconcurrent with any other live loads.
 - 6) * This truss has been designed for a live load of 20.0psf on the bottom chord in all areas with a clearance greater than 6-0-0 between the bottom chord and any other members.
 - 7) Provide mechanical connection (by others) of truss to bearing plate capable of withstanding 100 lb uplift at joint(s) 5, 2, 6.
 - 8) Beveled plate or shim required to provide full bearing surface with truss chord at joint(s) 2.



February 1, 2021

WARNING - Verify design parameters and READ NOTES ON THIS AND INCLUDED MITEK REFERENCE PAGE MII-7473 rev. 5/19/2020 BEFORE USE.
 Design valid for use only with MiTek® connectors. This design is based only upon parameters shown, and is for an individual building component, not a truss system. Before use, the building designer must verify the applicability of design parameters and properly incorporate this design into the overall building design. Bracing indicated is to prevent buckling of individual truss web and/or chord members only. Additional temporary and permanent bracing is always required for stability and to prevent collapse with possible personal injury and property damage. For general guidance regarding the fabrication, storage, delivery, erection and bracing of trusses and truss systems, see **ANSI/TPI1 Quality Criteria, DSB-89 and BCSI Building Component Safety Information** available from Truss Plate Institute, 2670 Crain Highway, Suite 203 Waldorf, MD 20601



818 Soundside Road
 Edenton, NC 27932

Job	Truss	Truss Type	Qty	Ply	Lot 10 Pendegrft Rd.	E15364194
J0621-4013	M02	MONOPITCH	8	1		

Comtech, Inc, Fayetteville, NC - 28314,

8.330 s Oct 7 2020 MiTek Industries, Inc. Sun Jan 31 13:50:37 2021 Page 1

ID:0iJzhz3vp6ahZXSx7jdYHSym1hi-Y6JXWtzmSQMYcAibLfSZpNJexKwI8CzE5vjpL5zppjm

Job Reference (optional)



Scale = 1:11.3

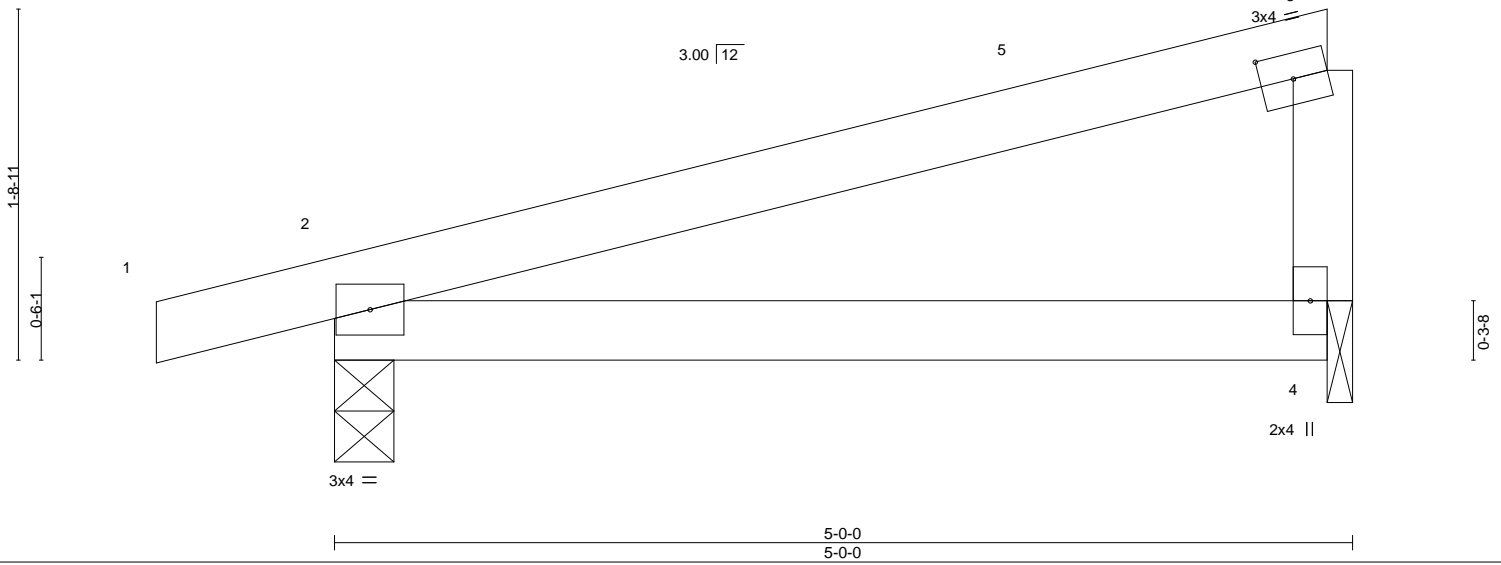

Plate Offsets (X,Y)-- [3:0-1-15,0-1-8]

LOADING (psf)	SPACING-		CSI.	DEFL.	in	(loc)	l/defl	L/d	PLATES	GRIP
TCLL 20.0	Plate Grip DOL 1.15	2-0-0	TC 0.28	Vert(LL) -0.03	2-4	>999	360		MT20	244/190
TCDL 10.0	Lumber DOL 1.15		BC 0.20	Vert(CT) -0.05	2-4	>999	240			
BCLL 0.0 *	Rep Stress Incr YES		WB 0.03	Horz(CT) 0.00	4	n/a	n/a			
BCDL 10.0	Code IRC2015/TPI2014		Matrix-P	Wind(LL) 0.00	2	****	240		Weight: 18 lb	FT = 20%

LUMBER-

TOP CHORD 2x4 SP No.1
 BOT CHORD 2x4 SP No.1
 WEBS 2x4 SP No.2

BRACING-

TOP CHORD Structural wood sheathing directly applied or 5-0-0 oc purlins.
 BOT CHORD Rigid ceiling directly applied or 10-0-0 oc bracing.

REACTIONS.

(size) 2=0-3-8, 4=0-1-8
 Max Horz 2=47(LC 8)
 Max Uplift 2=-54(LC 8), 4=-25(LC 12)
 Max Grav 2=256(LC 1), 4=181(LC 1)

FORCES. (lb) - Max. Comp./Max. Ten. - All forces 250 (lb) or less except when shown.

NOTES-

- 1) Wind: ASCE 7-10; Vult=130mph (3-second gust) Vasd=103mph; TC DL=6.0psf; BCDL=6.0psf; h=15ft; Cat. II; Exp C; Enclosed; MWFRS (envelope) and C-C Exterior(2) -0-10-8 to 3-6-5, Interior(1) 3-6-5 to 4-10-1 zone; C-C for members and forces & MWFRS for reactions shown; Lumber DOL=1.60 plate grip DOL=1.60
- 2) This truss has been designed for a 10.0 psf bottom chord live load nonconcurrent with any other live loads.
- 3) * This truss has been designed for a live load of 20.0psf on the bottom chord in all areas with a clearance greater than 6-0-0 between the bottom chord and any other members.
- 4) Bearing at joint(s) 4 considers parallel to grain value using ANSI/TPI 1 angle to grain formula. Building designer should verify capacity of bearing surface.
- 5) Provide mechanical connection (by others) of truss to bearing plate at joint(s) 4.
- 6) Provide mechanical connection (by others) of truss to bearing plate capable of withstanding 100 lb uplift at joint(s) 2, 4.



February 1, 2021

WARNING - Verify design parameters and READ NOTES ON THIS AND INCLUDED MITEK REFERENCE PAGE MII-7473 rev. 5/19/2020 BEFORE USE.

Design valid for use only with MiTek® connectors. This design is based only upon parameters shown, and is for an individual building component, not a truss system. Before use, the building designer must verify the applicability of design parameters and properly incorporate this design into the overall building design. Bracing indicated is to prevent buckling of individual truss web and/or chord members only. Additional temporary and permanent bracing is always required for stability and to prevent collapse with possible personal injury and property damage. For general guidance regarding the fabrication, storage, delivery, erection and bracing of trusses and truss systems, see

ANSI/TPI1 Quality Criteria, DSB-89 and BCSI Building Component

Safety Information available from Truss Plate Institute, 2670 Crain Highway, Suite 203 Waldorf, MD 20601



818 Soundside Road
 Edenton, NC 27932

Job	Truss	Truss Type	Qty	Ply	Lot 10 Pendegrft Rd.	E15364195
J0621-4013	P1	GABLE	2	1		

Comtech, Inc., Fayetteville, NC - 28314,

8.330 s Oct 7 2020 MiTek Industries, Inc. Sun Jan 31 13:50:38 2021 Page 1

ID:0iJ2hz3vp6ahZXs7jdYHSym1hi-0JtvjDzPCkUPEJHnvM_oLarm6kDCctf?NKZTntXzppj

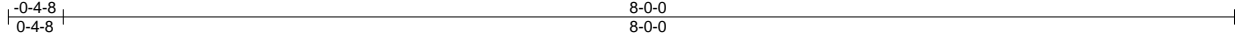

Scale = 1:15.7

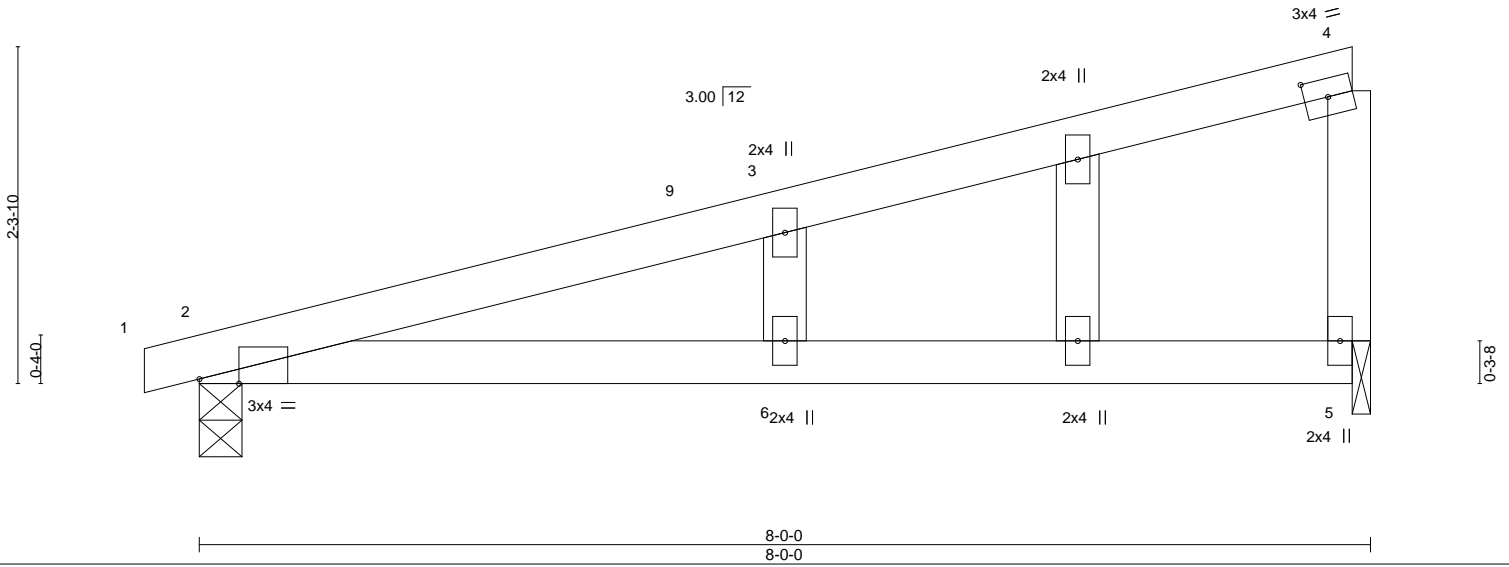

Plate Offsets (X,Y)-- [2:0-3-4,Edge], [4:0-1-15,0-1-8]

LOADING (psf)	SPACING-	CSL.	DEFL.	in (loc)	l/defl	L/d	PLATES	GRIP
TCLL 20.0	Plate Grip DOL 1.15	TC 0.45	Vert(LL) -0.16	6	>562	360	MT20	244/190
TCDL 10.0	Lumber DOL 1.15	BC 0.44	Vert(CT) -0.33	6	>280	240		
BCLL 0.0 *	Rep Stress Incr YES	WB 0.04	Horz(CT) -0.00	5	n/a	n/a		
BCDL 10.0	Code IRC2015/TPI2014	Matrix-S	Wind(LL) 0.26	6	>354	240	Weight: 30 lb	FT = 20%

LUMBER-
 TOP CHORD 2x4 SP No.1
 BOT CHORD 2x4 SP 2400F 2.0E
 WEBS 2x4 SP No.2
 OTHERS 2x4 SP No.2

BRACING-
 TOP CHORD Structural wood sheathing directly applied or 6-0-0 oc purlins.
 BOT CHORD Rigid ceiling directly applied or 10-0-0 oc bracing.

REACTIONS. (size) 2=0-3-8, 5=0-1-8
 Max Horz 2=97(LC 8)
 Max Uplift 2=-103(LC 8), 5=-99(LC 12)
 Max Grav 2=341(LC 1), 5=306(LC 1)

FORCES. (lb) - Max. Comp./Max. Ten. - All forces 250 (lb) or less except when shown.

- NOTES-**
- 1) Wind: ASCE 7-10; Vult=130mph (3-second gust) Vasd=103mph; TCDL=6.0psf; BCDL=6.0psf; h=15ft; Cat. II; Exp C; Enclosed; MWFRS (envelope) gable end zone and C-C Corner(3) 0-4-8 to 4-0-0, Exterior(2) 4-0-0 to 7-10-1 zone; C-C for members and forces & MWFRS for reactions shown; Lumber DOL=1.60 plate grip DOL=1.60
 - 2) Truss designed for wind loads in the plane of the truss only. For studs exposed to wind (normal to the face), see Standard Industry Gable End Details as applicable, or consult qualified building designer as per ANSI/TPI 1.
 - 3) Gable studs spaced at 2-0-0 oc.
 - 4) This truss has been designed for a 10.0 psf bottom chord live load nonconcurrent with any other live loads.
 - 5) * This truss has been designed for a live load of 20.0psf on the bottom chord in all areas with a clearance greater than 6-0-0 between the bottom chord and any other members.
 - 6) Bearing at joint(s) 5 considers parallel to grain value using ANSI/TPI 1 angle to grain formula. Building designer should verify capacity of bearing surface.
 - 7) Provide mechanical connection (by others) of truss to bearing plate at joint(s) 5.
 - 8) Provide mechanical connection (by others) of truss to bearing plate capable of withstanding 100 lb uplift at joint(s) 5 except (jt=lb) 2=103.

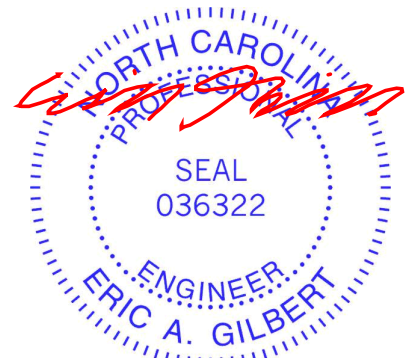

February 1, 2021

WARNING - Verify design parameters and READ NOTES ON THIS AND INCLUDED MITEK REFERENCE PAGE MII-7473 rev. 5/19/2020 BEFORE USE.

Design valid for use only with MiTek® connectors. This design is based only upon parameters shown, and is for an individual building component, not a truss system. Before use, the building designer must verify the applicability of design parameters and properly incorporate this design into the overall building design. Bracing indicated is to prevent buckling of individual truss web and/or chord members only. Additional temporary and permanent bracing is always required for stability and to prevent collapse with possible personal injury and property damage. For general guidance regarding the fabrication, storage, delivery, erection and bracing of trusses and truss systems, see

ANSI/TPI1 Quality Criteria, DSB-89 and BCSI Building Component

Safety Information available from Truss Plate Institute, 2670 Crain Highway, Suite 203 Waldorf, MD 20601



818 Soundside Road
 Edenton, NC 27932

Job	Truss	Truss Type	Qty	Ply	Lot 10 Pendegrft Rd.	E15364196
J0621-4013	P2	MONOPITCH	6	1		

Comtech, Inc, Fayetteville, NC - 28314,

8.330 s Oct 7 2020 MiTek Industries, Inc. Sun Jan 31 13:50:38 2021 Page 1
 ID:0iJ2hz3vp6ahZXSx7jdYHSym1hi-0JtvjDzPCkUPEJHnvM_oLarf0kEQtf4NKZTntXzppj

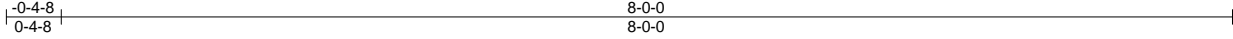

Scale = 1:15.7

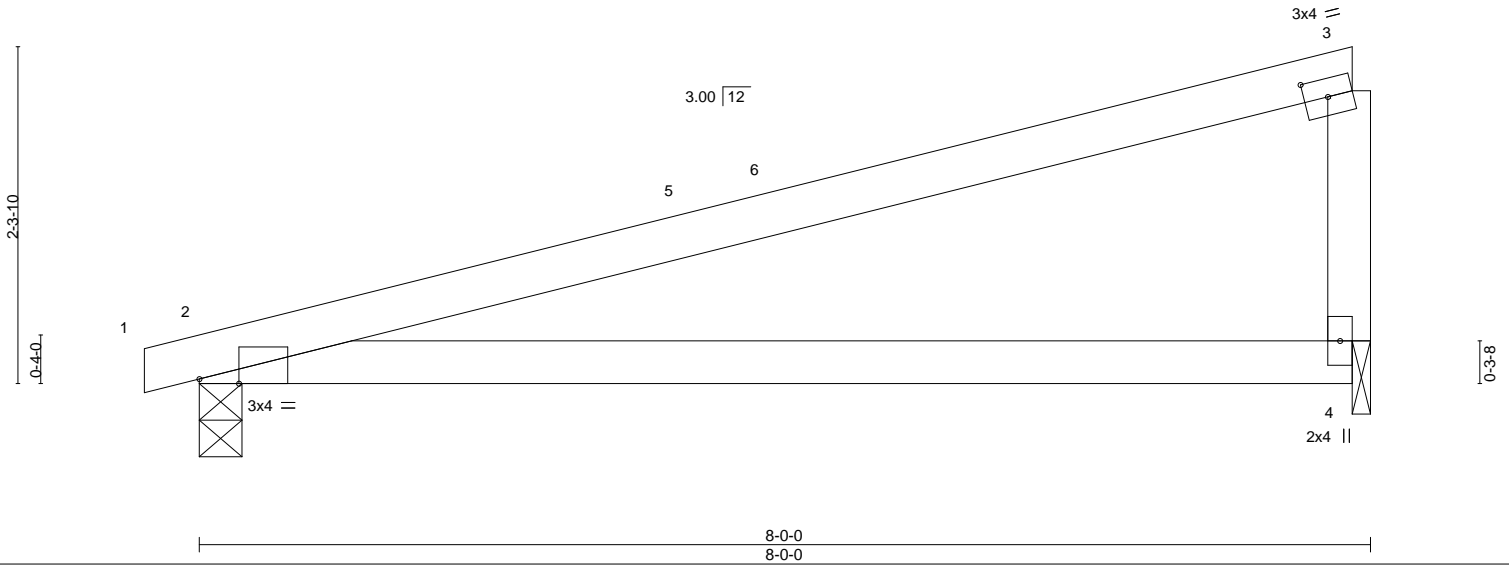

Plate Offsets (X,Y)-- [2:0-3-4,Edge], [3:0-1-15,0-1-8]

LOADING (psf)	SPACING-	CSI.	DEFL.	in (loc)	l/defl	L/d	PLATES	GRIP
TCLL 20.0	Plate Grip DOL 1.15	TC 0.90	Vert(LL) -0.15	2-4	>624	360	MT20	244/190
TCDL 10.0	Lumber DOL 1.15	BC 0.36	Vert(CT) -0.30	2-4	>312	240		
BCLL 0.0 *	Rep Stress Incr YES	WB 0.04	Horz(CT) 0.00	4	n/a	n/a		
BCDL 10.0	Code IRC2015/TPI2014	Matrix-P	Wind(LL) 0.32	2-4	>285	240	Weight: 27 lb	FT = 20%

LUMBER-
 TOP CHORD 2x4 SP No.1
 BOT CHORD 2x4 SP 2400F 2.0E
 WEBS 2x4 SP No.2

BRACING-
 TOP CHORD Structural wood sheathing directly applied or 2-2-0 oc purlins.
 BOT CHORD Rigid ceiling directly applied or 10-0-0 oc bracing.

REACTIONS. (size) 2=0-3-8, 4=0-1-8
 Max Horz 2=68(LC 8)
 Max Uplift 2=-130(LC 8), 4=-126(LC 8)
 Max Grav 2=341(LC 1), 4=306(LC 1)

FORCES. (lb) - Max. Comp./Max. Ten. - All forces 250 (lb) or less except when shown.

- NOTES-**
- 1) Wind: ASCE 7-10; Vult=130mph (3-second gust) Vasd=103mph; TCDL=6.0psf; BCDL=6.0psf; h=15ft; Cat. II; Exp C; Enclosed; MWFRS (envelope) and C-C Exterior(2) -0-4-8 to 4-0-5, Interior(1) 4-0-5 to 7-10-1 zone; porch left exposed;C-C for members and forces & MWFRS for reactions shown; Lumber DOL=1.60 plate grip DOL=1.60
 - 2) This truss has been designed for a 10.0 psf bottom chord live load nonconcurrent with any other live loads.
 - 3) * This truss has been designed for a live load of 20.0psf on the bottom chord in all areas with a clearance greater than 6-0-0 between the bottom chord and any other members.
 - 4) Bearing at joint(s) 4 considers parallel to grain value using ANSI/TPI 1 angle to grain formula. Building designer should verify capacity of bearing surface.
 - 5) Provide mechanical connection (by others) of truss to bearing plate at joint(s) 4.
 - 6) Provide mechanical connection (by others) of truss to bearing plate capable of withstanding 100 lb uplift at joint(s) except (jt=lb) 2=130, 4=126.

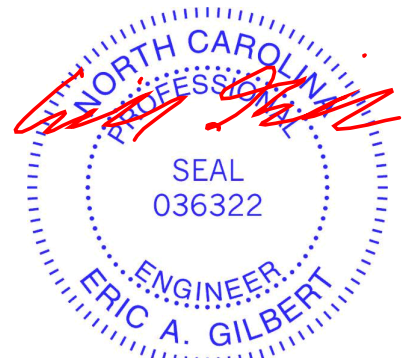

February 1, 2021

WARNING - Verify design parameters and READ NOTES ON THIS AND INCLUDED MITEK REFERENCE PAGE MII-7473 rev. 5/19/2020 BEFORE USE.
 Design valid for use only with MiTek® connectors. This design is based only upon parameters shown, and is for an individual building component, not a truss system. Before use, the building designer must verify the applicability of design parameters and properly incorporate this design into the overall building design. Bracing indicated is to prevent buckling of individual truss web and/or chord members only. Additional temporary and permanent bracing is always required for stability and to prevent collapse with possible personal injury and property damage. For general guidance regarding the fabrication, storage, delivery, erection and bracing of trusses and truss systems, see **ANSI/TPI1 Quality Criteria, DSB-89 and BCSI Building Component Safety Information** available from Truss Plate Institute, 2670 Crain Highway, Suite 203 Waldorf, MD 20601



818 Soundside Road
 Edenton, NC 27932

Symbols

PLATE LOCATION AND ORIENTATION

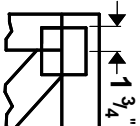

Center plate on joint unless x, y offsets are indicated. Dimensions are in ft-in-sixteenths. Apply plates to both sides of truss and fully embed teeth.

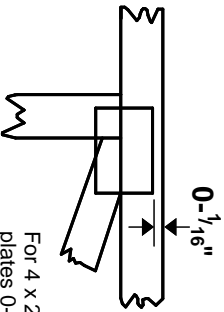

For 4 x 2 orientation, locate plates 0- 1/16" from outside edge of truss.



This symbol indicates the required direction of slots in connector plates.

* Plate location details available in **MITek 20/20 software** or upon request.

PLATE SIZE

4 X 4

The first dimension is the plate width measured perpendicular to slots. Second dimension is the length parallel to slots.

LATERAL BRACING LOCATION



Indicated by symbol shown and/or by text in the bracing section of the output. Use T or I bracing if indicated.

BEARING



Indicates location where bearings (supports) occur. Icons vary but reaction section indicates joint number where bearings occur. Min size shown is for crushing only.

Industry Standards:

ANSI/TPI 1: National Design Specification for Metal Plate Connected Wood Truss Construction.
DSB-89: Design Standard for Bracing, Building Component Safety Information, Guide to Good Practice for Handling, Installing & Bracing of Metal Plate Connected Wood Trusses.

Numbering System

6-4-8
dimensions shown in ft-in-sixteenths
(Drawings not to scale)

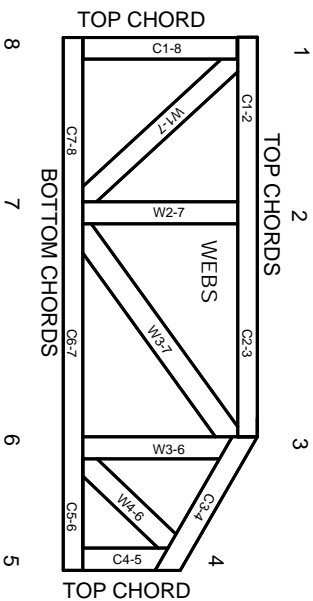

JOINTS ARE GENERALLY NUMBERED/LETTERED CLOCKWISE AROUND THE TRUSS STARTING AT THE JOINT FARTHEST TO THE LEFT.

CHORDS AND WEBS ARE IDENTIFIED BY END JOINT NUMBERS/LETTERS.

PRODUCT CODE APPROVALS

ICC-ES Reports:

ESR-1311, ESR-1352, ESR1988
ER-3907, ESR-2362, ESR-1397, ESR-3282

Trusses are designed for wind loads in the plane of the truss unless otherwise shown.

Lumber design values are in accordance with ANSI/TPI 1 section 6.3 These truss designs rely on lumber values established by others.

© 2012 MITteK® All Rights Reserved



MITek Engineering Reference Sheet: Mill-7473 rev. 5/19/2020



General Safety Notes

Failure to Follow Could Cause Property Damage or Personal Injury

1. Additional stability bracing for truss system, e.g. diagonal or X-bracing, is always required. See BCSI.
2. Truss bracing must be designed by an engineer. For wide truss spacing, individual lateral braces themselves may require bracing, or alternative Tor I bracing should be considered.
3. Never exceed the design loading shown and never stack materials on inadequately braced trusses.
4. Provide copies of this truss design to the building designer, erection supervisor, property owner and all other interested parties.
5. Cut members to bear tightly against each other.
6. Place plates on each face of truss at each joint and embed fully. Knots and wane at joint locations are regulated by ANSI/TPI 1.
7. Design assumes trusses will be suitably protected from the environment in accord with ANSI/TPI 1.
8. Unless otherwise noted, moisture content of lumber shall not exceed 19% at time of fabrication.
9. Unless expressly noted, this design is not applicable for use with fire retardant, preservative treated, or green lumber.
10. Camber is a non-structural consideration and is the responsibility of truss fabricator. General practice is to camber for dead load deflection.
11. Plate type, size, orientation and location dimensions indicated are minimum plating requirements.
12. Lumber used shall be of the species and size, and in all respects, equal to or better than that specified.
13. Top chords must be sheathed or purlins provided at spacing indicated on design.
14. Bottom chords require lateral bracing at 10 ft. spacing, or less, if no ceiling is installed, unless otherwise noted.
15. Connections not shown are the responsibility of others.
16. Do not cut or alter truss member or plate without prior approval of an engineer.
17. Install and load vertically unless indicated otherwise.
18. Use of green or treated lumber may pose unacceptable environmental, health or performance risks. Consult with project engineer before use.
19. Review all portions of this design (front, back, words and pictures) before use. Reviewing pictures alone is not sufficient.
20. Design assumes manufacture in accordance with ANSI/TPI 1 Quality Criteria.
21. The design does not take into account any dynamic or other loads other than those expressly stated.