

Boise Cascade
www.blr.com

1135 ROBESON STREET
FAYETTEVILLE, NC 28305
V (910) 485-1111

7601 BOEING DRIVE
GREENSBORO, NC 27409
V (336) 884-5454

3189 NC HIGHWAY 5
ABERDEEN NC 28315
V (910) 944-2516

This layout and associated materials list has been prepared based on project plans and/or information provided to Builders FirstSource (BFS). It remains the responsibility of the builder, architect, designer, or other responsible persons to review this information to assure that it is appropriate, accurate, complete and complies with applicable building codes.

- GENERAL NOTES:**
- 1.) READ THE INSTALLATION GUIDE BEFORE FRAMING.
 - 2.) ALL WALLS SHOWN ARE LOAD BEARING UNLESS NOTED OTHERWISE. WALLS NOT SHOWN ARE CONSIDERED NON-LOAD BEARING.
 - 3.) UNLESS STATED OTHERWISE ALL CEILING & ROOF LOADS BRACE DIRECTLY TO LOAD BEARING WALLS SUPPORTED BY FOUNDATION.
 - 4.) CONTACT BUILDERS FIRSTSOURCE BEFORE MAKING ANY ALTERATIONS OR ADJUSTMENTS...FAILURE TO DO SO MAY RESULT IN COSTLY REPAIRS.

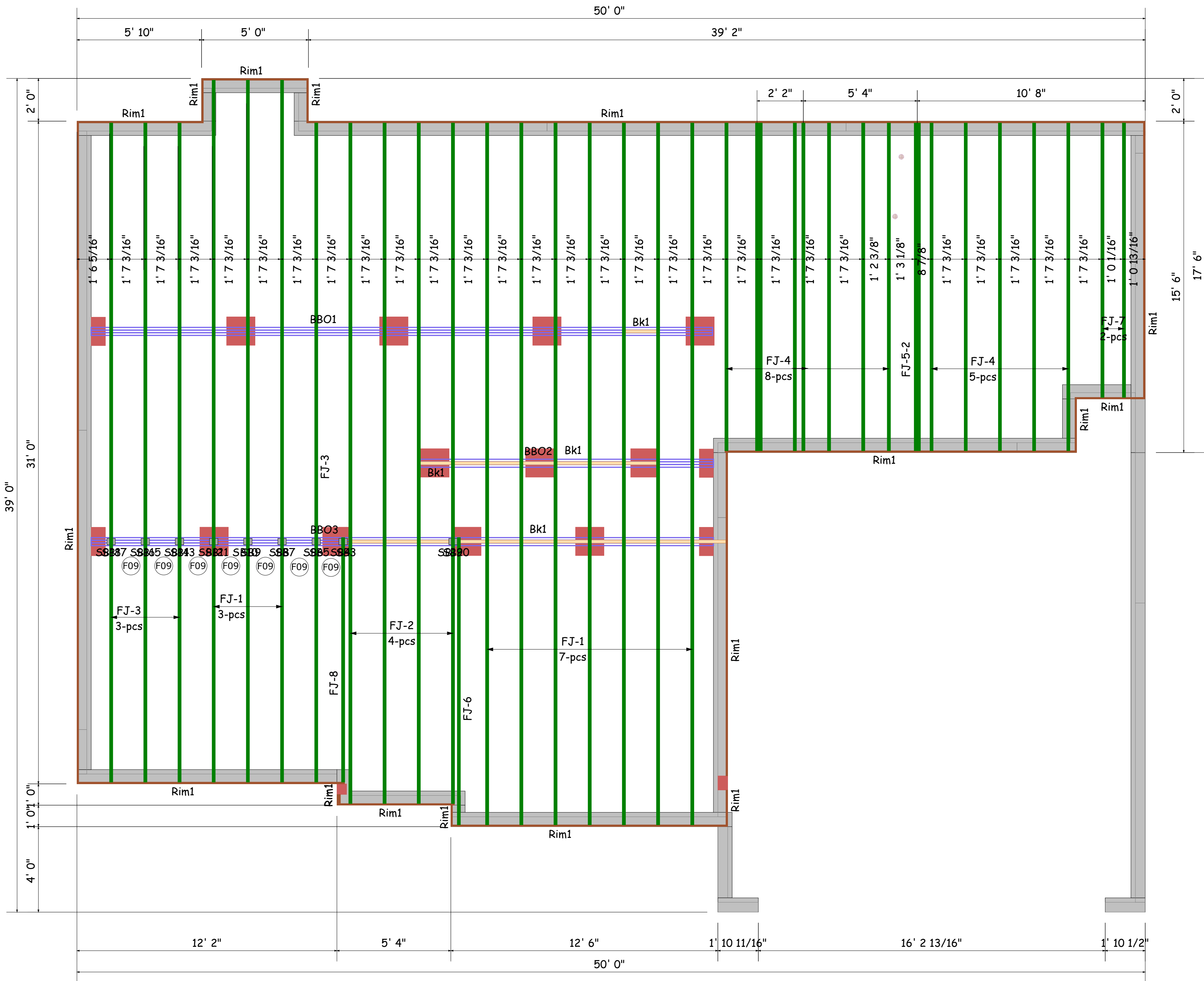

Products				
PlotID	Length	Product	Plies	Net Qty
FJ-1	32' 10"	11-7/8" BCI@ 4500s-1.8	1	10
FJ-2	31' 10"	11-7/8" BCI@ 4500s-1.8	1	4
FJ-3	30' 10"	11-7/8" BCI@ 4500s-1.8	1	4
FJ-4	15' 4"	11-7/8" BCI@ 4500s-1.8	1	13
FJ-5-2	15' 4"	11-7/8" BCI@ 4500s-1.8	2	2
FJ-6	13' 5 1/4"	11-7/8" BCI@ 4500s-1.8	1	1
FJ-7	12' 10"	11-7/8" BCI@ 4500s-1.8	1	2
FJ-8	11' 5 1/4"	11-7/8" BCI@ 4500s-1.8	1	1
Rim1	12' 0"	1" x 11-7/8" BC RIM BOARD OSB	1	15
Bk1	28' 0"	11-7/8" BCI@ 4500s-1.8	1	1

H&H Homes

SOUTHPORT

CRAWL EWP PLACEMENT PLAN

Builders FirstSource, Central Carolina Markets

DRAWN BY: AJ Napier

SCALE: NTS

DATE: 2/14/2020

JOB NUMBER:

MINIMUM DESIGN DATA

LIVE LOAD 40 PSF
DEAD LOAD 10 PSF

TOTAL LOAD 50 PSF

DOL = 100%

DEFLECTION CRITERIA
L/480 (MINIMUM)

ARCHITECTURAL PLAN DATE

XX-XX-XX

REVISED ARCH. PLAN DATE

XX-XX-XX

XXXXXXXX



Boise Cascade
www.bldr.com

1135 ROBESON STREET
FAYETTEVILLE, NC 28305
V (910) 485-1111

7601 BOEING DRIVE
GREENSBORO, NC 27409
V (336) 884-5454

3189 NC HIGHWAY 5
ABERDEEN NC 28315
V (910) 944-2516

This layout and associated materials list has been prepared based on project plans and/or information provided to Builders FirstSource (BFS). It remains the responsibility of the builder, architect, designer, or other responsible persons to review this information to assure that it is appropriate, accurate, complete and complies with applicable building codes.

GENERAL NOTES:
1.) READ THE INSTALLATION GUIDE BEFORE FRAMING.
2.) ALL WALLS SHOWN ARE LOAD BEARING UNLESS NOTED OTHERWISE. WALLS NOT SHOWN ARE CONSIDERED NON-LOAD BEARING.
3.) UNLESS STATED OTHERWISE ALL CEILING & ROOF LOADS BRACE DIRECTLY TO LOAD BEARING WALLS SUPPORTED BY FOUNDATION.
4.) CONTACT BUILDERS FIRSTSOURCE BEFORE MAKING ANY ALTERATIONS OR ADJUSTMENTS...FAILURE TO DO SO MAY RESULT IN COSTLY REPAIRS.

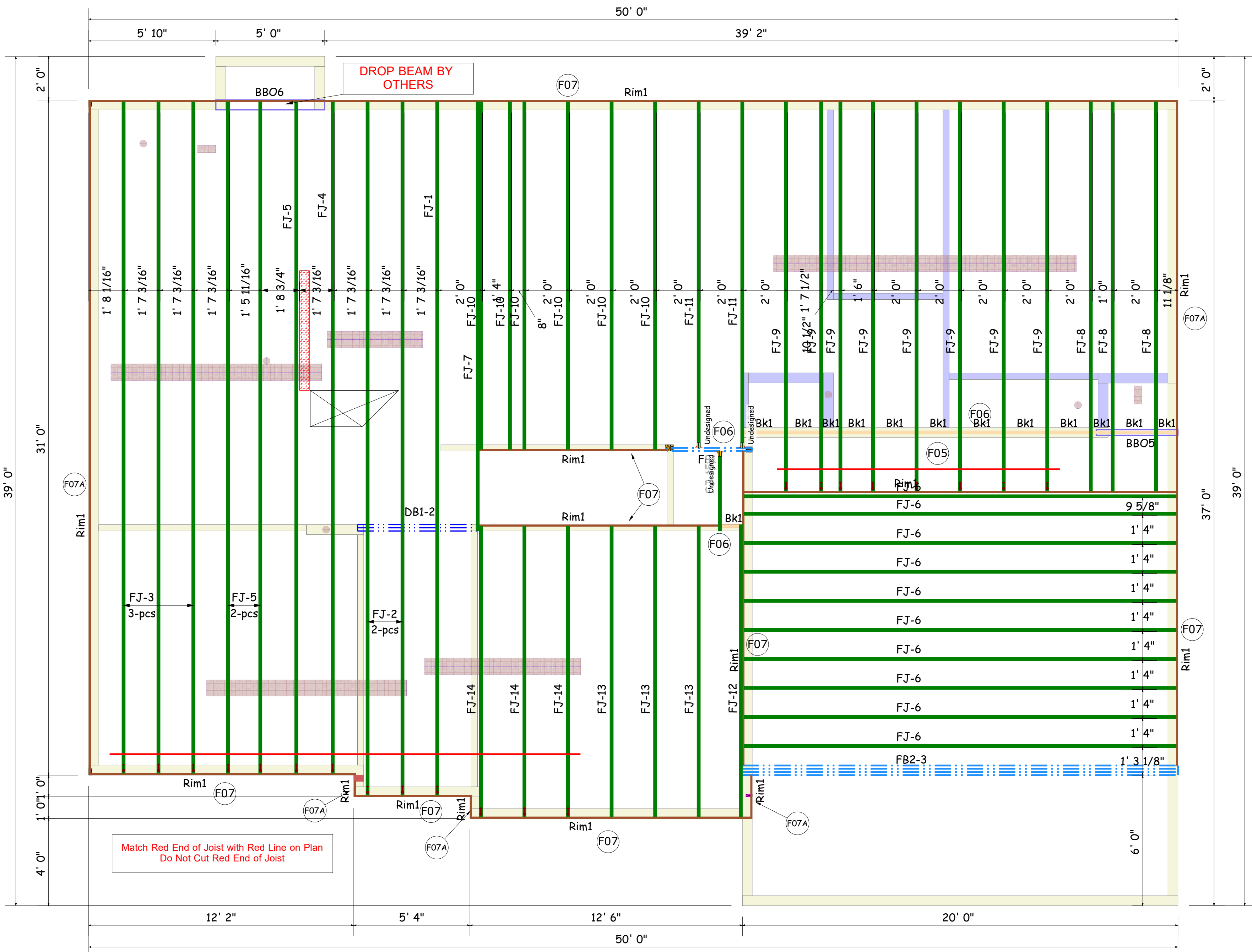
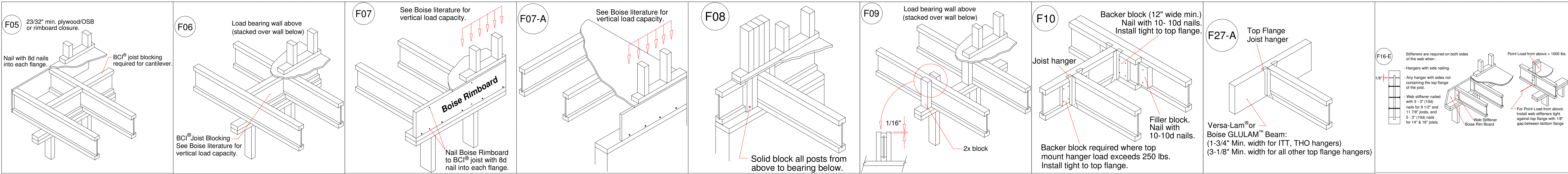

PlotID	Length	Product	Plies	Net Qty
FJ-1	31' 10"	14" BCI® 4500s-1.8	1	1
FJ-2	31' 10"	14" BCI® 4500s-1.8	1	2
FJ-3	30' 10"	14" BCI® 4500s-1.8	1	3
FJ-4	30' 10"	14" BCI® 4500s-1.8	1	1
FJ-5	30' 10"	14" BCI® 4500s-1.8	1	3
FJ-6	19' 10"	14" BCI® 4500s-1.8	1	10
FJ-7	19' 8 1/2"	14" BCI® 4500s-1.8	1	1
FJ-8	17' 10 1/2"	14" BCI® 4500s-1.8	1	3
FJ-9	17' 10 1/2"	14" BCI® 4500s-1.8	1	8
FJ-10	15' 11 1/2"	14" BCI® 4500s-1.8	1	6
FJ-11	15' 10 3/4"	14" BCI® 4500s-1.8	1	2
FJ-12	13' 5"	14" BCI® 4500s-1.8	1	1
FJ-13	13' 4"	14" BCI® 4500s-1.8	1	3
FJ-14	13' 4"	14" BCI® 4500s-1.8	1	3
FJ-15	3' 8"	14" BCI® 4500s-1.8	1	1
DB1-2	6' 0"	1-3/4" x 9-1/4" VERSA-LAM® 2.0 3100 SP	2	2
FB1	4' 0"	1-3/4" x 14" VERSA-LAM® 2.0 3100 SP	1	1
FB2-3	20' 0"	1-3/4" x 24" VERSA-LAM® 2.0 3100 SP	3	3
Rim1	12' 0"	1" x 14" BC RIM BOARD OSB	1	17
Bk1	20' 0"	14" BCI® 4500s-1.8	1	1

H&H Homes
SOUTHPORT
2ND FLOOR EWP PLACEMENT PLAN
Builders FirstSource, Central Carolina Markets
DRAWN BY: AJ Napier DATE: 2/14/2020
SCALE: NTS JOB NUMBER:

MINIMUM DESIGN DATA
LIVE LOAD 40 PSF
DEAD LOAD 10 PSF
TOTAL LOAD 50 PSF
DOL = 100%
DEFLECTION CRITERIA L/480 (MINIMUM)
ARCHITECTURAL PLAN DATE XX-XX-XX
REVISED ARCH. PLAN DATE XX-XX-XX
Sheet
1 of 1